

Chelsea® 277H Series

10-Bolt Powershift for Hino 338



Overview:

A rugged and durable truck such as the HINO 338 requires innovative P.T.O. solutions. Allison chose Chelsea to join their engineers in developing P.T.O.s specifically for their World Transmissions. Now the versatile 277 Series Powershift has a new Option. The 277H that will provide you with a P.T.O. that gives you clearance on the right (passenger) side of the Allison 3000 Series transmission, for Hino's 338 vocational chassis applications. With ever changing chassis designs and the issues of P.T.O. installation clearance, Chelsea was the first P.T.O. manufacturer to design a "sculptured" housing for the Hino 338 chassis left side (Driver) applications. This industry setting standard is now carried over to the right side of the Allison 3000 Series transmission with the 277H in a new P.T.O. housing. The new "3" assembly arrangement provides the clearance needed to install the P.T.O. and offers the installer the option of selecting either left, right or both P.T.O. apertures on the transmission for their design needs. A rugged and durable solution for your vocational truck needs is what you will find with the Hino 338, Allison 3000 and Chelsea 277H Powershift P.T.O.

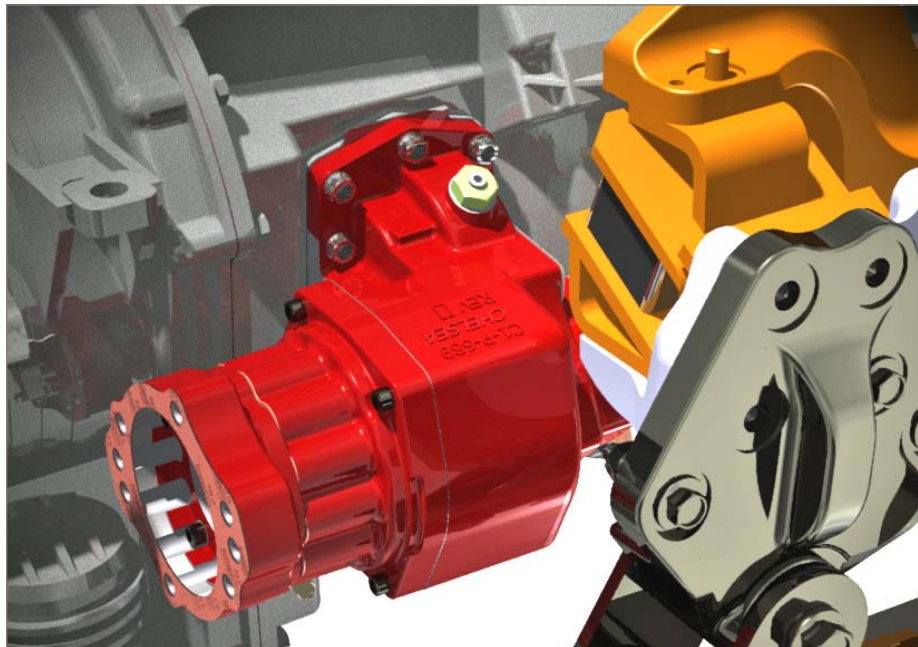

- Dump
- Utility
- Snow & Ice Removal
- Refuse/Recycling
- Petroleum/Gas Delivery

Contact Information:

Parker Hannifin Corporation
Chelsea Products Division
8225 Hacks Cross Road
Olive Branch, MS 38654 USA

Phone: 1-888-PH4-TRUK
(1-888-744-8785)

Fax: 1-662-895-1069
chelseacustserv@parker.com

www.parker.com/chelsea

Product Features and Benefits:

- Exceeds the torque capacity of a 6-Bolt P.T.O. while offering the tighter sealing of a 10-Bolt pattern
- Combo Valve shift option available for P.T.O./Dump Pump systems
- SuperTorque™ gears available for 20% higher intermittent torque ratings
- Cartridge Valve Assembly for reduced interference
- Wet Spline Options available
- Shaft Brake option (patent #7159701) available for product pump applications
- Industry First Rotatable Wet Spline



ENGINEERING YOUR SUCCESS.

Model Number Designation

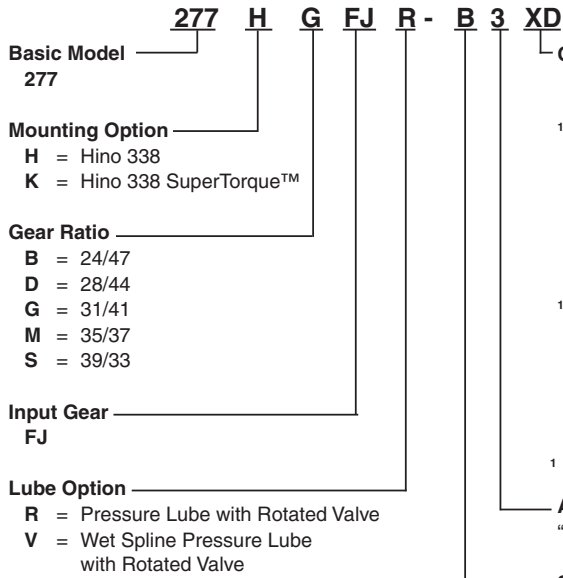

Output Option

- XD = 1-1/4" Rd Standard Shaft
- XE = S.A.E. "A" 2-Bolt 5/8" - 9T
- ¹ XK = S.A.E. "B" 2/4-Bolt 7/8" - 13T
- XP = S.A.E. "A" 2-Bolt 7/8" - 13T
- XR = Chelsea Special 7/8" - 13T
- XX = Tapered Output Shaft
- XV = 1-3/8" - 10T Spline w/1410 Companion Flange
- XY = DIN 5462 8T
- ¹ AF = S.A.E. "BB" 2 or 4-Bolt 1" - 15T
- RF = Rotatable S.A.E. "BB" 2-Bolt 1" - 15T
- RG = Rotatable S.A.E. "BB" 4-Bolt 1" - 15T
- PF = Rotatable S.A.E. "BB" 2-Bolt 1" - 15T for Parker Sculptured Pump
- PA = Rotatable S.A.E. "B" 2-Bolt 7/8" - 13T for Parker Sculptured Pump
- BA = 1-1/4" Rd Standard Shaft w/Brake
- ¹ ZY = DIN 5462 8T (shorter than XY output)
- ¹ RK = Rotatable S.A.E. "B" 2/4-Bolt 7/8" - 13T
- ¹ RM = Rotatable S.A.E. "B" 2/4-Bolt 1.0" - 15T
- G220 = RB flange w/G102-1-2.0R-4S-AS Pump

¹ Can be ordered with or without Wetspline

Assembly Arrangement

"3" - Gear Forward, Shaft Rear, Bulge Down - Right Side of Transmission

Shift Option

- B = 12V Hydraulic Valve
- D = 24V Hydraulic Valve
- ² F = 24V Remote Valve Kit 329392X
- G = 12V Remote Hydraulic Valve
- H = 24V Remote Hydraulic Valve
- K = 12V Electronic Overspeed Ctrl
- L = 24V Electronic Overspeed Ctrl
- ² M = 12V Minus Installation Kit 329024-12X
- ² N = 24V Minus Installation Kit 329024-24X
- S = P.T.O. & Combo Valve
- T = P.T.O. & Combo Valve Less Kick Out & Neutral Spring Return

² Europe Only

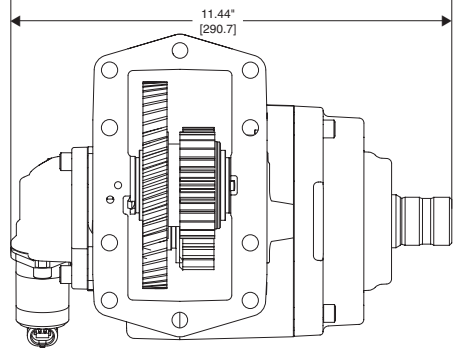
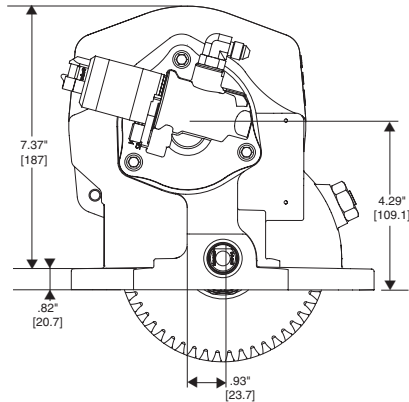

Series Specifications Chart – 277H Series

	277*B	277*D	277*G	277*M	277*S	277KB	277KD	277KG	277KM	277KS
						SuperTorque™				
Standard Output Shaft Size	1-1/4" Round w/key									
Intermittent Torque Rating (Lbs. ft.)	335	325	300	265	250	402	390	360	318	265
Intermittent Torque Rating (N.m.)	454	441	407	359	339	545	529	488	431	359
Horsepower Rating for Intermittent Service										
At 500 R.P.M. of Output Shaft (HP)	32	31	29	25	24	38	37	34	30	25
At 1000 R.P.M. of Output Shaft (HP)	64	62	57	50	48	77	74	69	61	50
At 500 R.P.M. of Output Shaft (Kw)	24	23	21	19	18	29	28	26	23	19
At 1000 R.P.M. of Output Shaft (Kw)	48	46	43	38	36	57	56	51	45	38
Approximate Weight:						49 lbs. [22 kg]				

