



AXIAL PISTON PUMPS SERIES P2/P3

Variable Displacement

Table of Contents

Technical Information	3
Ordering Code.....	4
Control Options “PA”	6
Control Options “RA”	7
Control Options “LA” and “LB”	8
Control Options “TA”, “TB”, “TC” and “TD”	9
P2 Typical Torque Control Characteristics.....	10
P3 Typical Torque Control Characteristics.....	11
Hydr. Generated Noise / Performance Curves	12
Ripple chamber	12
P2 Performance data	
P2 Noise characteristics at max./min. displacement	12
P2 Series - typical drive power at full displacement	13
P2 Series - typical compensated input power	14
P2 Series - typical efficiency at full displacement at 1800 rpm.	15
P2 Series - typical flow vs. pressure	16
P2 Series - typical compensated case drain flow.....	17
P2 Series - typical inlet characteristics vs. speed at various percentage displacements.....	18
P2 Dimensions	
P2060.....	19
P2075.....	22
P2105	25
P2145	28
P2 Shaft options.....	32
Torque control dimensions.....	32
P3 Performance data	
P3 Noise characteristics at max./min. displacement	33
P3 Series - typical drive power at full displacement.....	33
P3 Series - typical compensated input power	34
P3 Series - typical efficiency at full displ. at 1800 rpm.....	34
P3 Series - typical flow vs. pressure	35
P3 Series - typical compensated drain flow	35
P3 Series - typical inlet characteristics vs. speed at various percentage displacements.....	36
P3 Dimensions	
P3105	37
P3145	40
P3 Shaft options.....	44
Torque control dimensions.....	44
General Installation Information	45
Multiple pump combinations	45
Fluid recommendations, Seals	46

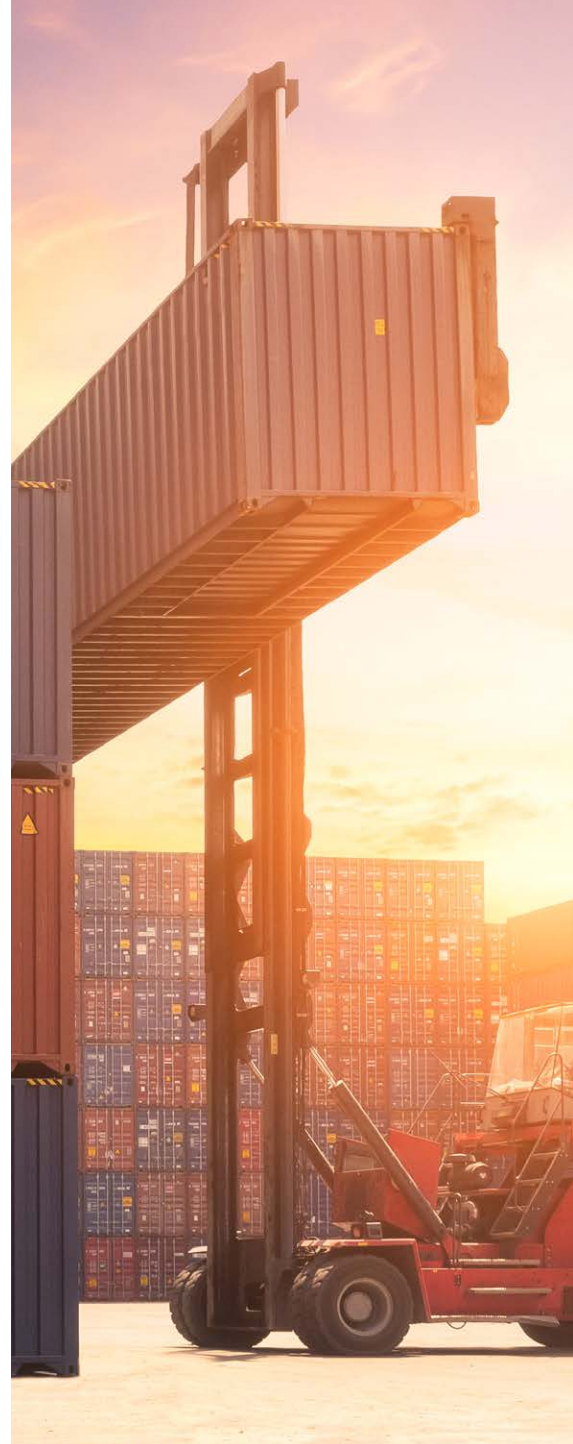

If you have questions about the products contained in this catalog, or their applications, please contact:
Parker Hannifin EMEA Sàrl European Headquarters
parker.com/msg30

TECHNICAL INFORMATION

Technical Features

Variable displacement, axial piston pumps for open circuit hydraulic systems

Available as standard (P2) or supercharged (P3) version

Optimized for mobile applications:

- Dedicated envelope design and unique port layout
- High self-priming speed
- Standard integrated pre-compression volume
- Heavy duty approval (size 105 and 145) for increased power density

P2 Series



Customer Benefits

- Cost saving installation by direct PTO mount
- High productivity by maximized output flow
- High altitude operation capability
- Low noise level and reduced flow ripple

P3 Series



Technical Data

Frame size		P2 Series				P3 Series	
		P2060	P2075	P2105	P2145	P3105	P3145
Max. displacement	[cm ³ /rev]	60	75	105	145	105	145
Self-priming speed at 1 bar absolute inlet pressure ¹⁾	[rpm]	2800	2500	2300	2200	2600	2500
Nominal pressure ²⁾	[bar]	320	320	350	350	350	350
Min. inlet pressure, absolute ¹⁾	[bar]	0.8	0.8	0.8	0.8	0.8	0.8
Max. inlet pressure, absolute	[bar]	10	10	10	10	1.5	1.5
Max. case drain pressure, absolute	[bar]	1.5	1.5	1.5	1.5	1.5	1.5
Min. outlet pressure, absolute	[bar]	15	15	15	15	15	15
Noise level at full flow at 1800 rpm and 250 bar	[dbA]	74	76	78	80	78	80
Weight with load sense control	[kg]	37	44	63	78	62	76
Mass moment of inertia (at axis of shaft)	[kg m ²]	0.0061	0.0101	0.0168	0.0241	0.0177	0.0264

1) Detailed inlet characteristics can be taken from page 18 and 36

2) For maximum operating pressures exceeding above mentioned nominal ratings please consult manufacturer

ORDERING CODE

Pump series

Code	Pump series
2	Standard
3	Super charged

Pump size

Code	Pump size (max. displacement in cc/rev)	
	P2	P3
060	60	-
075	75	-
105	105	105
145	145	145

Shaft rotation

Code	Shaft rotation ¹⁾
R	Right (CW)
L	Left (CCW)

¹⁾ Viewed from shaft end.

Displacement (%)

Code	% of max. displacement
00	100 % stroke standard factory set
XX	Range is 70 % to 99 %

Shaft type

Code	Shaft type (splined) ^{2) 3)}	Pump size			
		060	075	105	145
B1	SAE B	•	–	–	–
B2	SAE B-B	•	•	–	–
C1	SAE C	•	•	•	•
C2	SAE C-C	–	•	•	•
C3	SAE C, w/o undercut	•	•	•	•
D1	SAE D	–	–	•	•
D2	SAE D, w/o undercut	–	–	•	•
M6	DIN 5480, W50	–	–	–	•

²⁾ See pages 32 and 44 for permissible input torque.
³⁾ For further shaft options please consult manufacturer.

Mounting flange

Code	Mounting flange	Pump size			
		060	075	105	145
B	SAE B 2-bolt	•	–	–	–
C	SAE C 2-bolt	–	–	–	•
	SAE C 2 & 4-bolt	–	•	•	–
	SAE C 4-bolt	•	–	–	⁴⁾
D	SAE D 4-bolt	–	–	–	•

⁴⁾ Please consult manufacturer.

Max. pressure setting

Code	Max. pressure setting	
	Pressure setting in 10 bar increments	
XX	060	100 to 320 bar, XX = [10...32]
	075	
	105	100 to 350 bar, XX = [10...35]
	145	

Controls

Code	Controls
PA	Max. pressure control
RA	Remote pressure control with max. pressure control
LA	Load sensing control w/o bleed-off orifice, with max. pressure control
LB	Load sensing control with bleed-off orifice, with max. pressure control
TA	Torque control, load sensing w/o bleed-off orifice and max. pressure control, range 20...60 % of reference torque value
TB	Torque control, load sensing with bleed-off orifice and max. pressure control, range 20...60% of reference torque value
TC	Torque control, load sensing w/o bleed-off orifice and max. pressure control, range 50...90 % of reference torque value
TD	Torque control, load sensing with bleed-off orifice and max. pressure control, range 50...90 % of reference torque value

ORDERING CODE

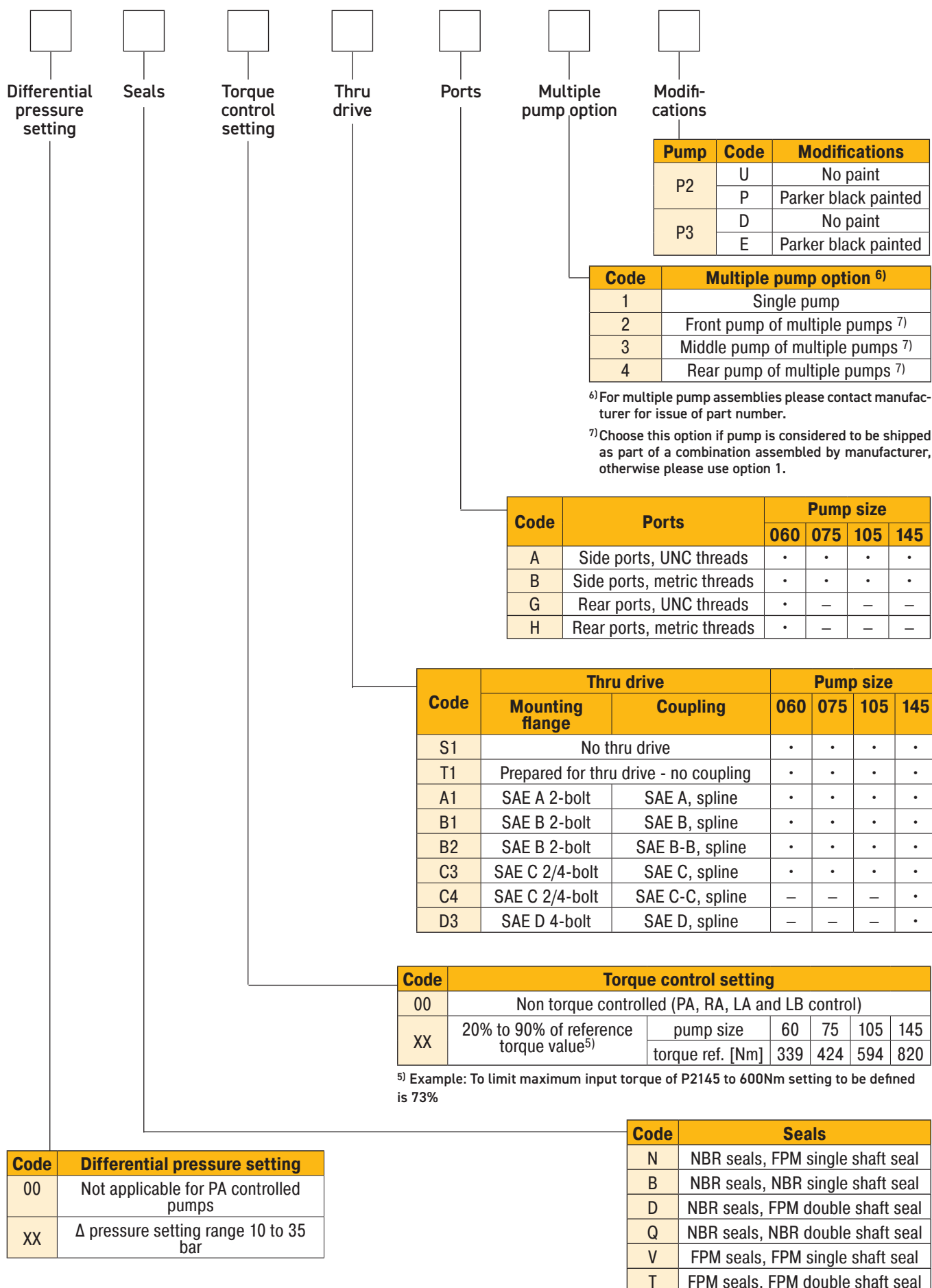

CONTROL OPTIONS "PA"

Pressure control

The pressure control is used to limit the maximum system pressure. The control acts such that full pump displacement is achieved unless the load pressure reaches the maximum setting of the control. If pump flow is restricted by the system valve, the pump will provide only the flow demanded, but at the maximum pressure setting of the compensator control. If the outlet flow is completely blocked, the pump will de-stroke to zero displacement and maintain the pressure at the setting of the compensator spring.

Response times of the pump are collected from a circuit as below by measuring the pumps swash angle movement at different pressures.

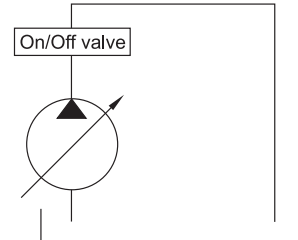

P2 Control schematics

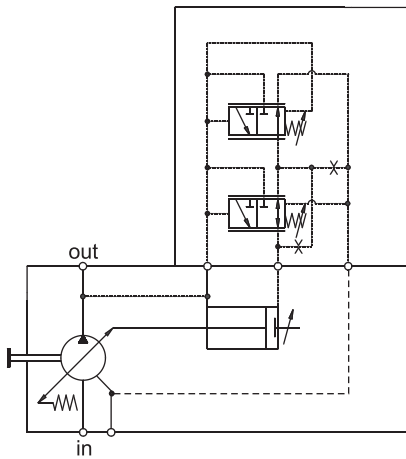

Dynamic characteristic of flow control *

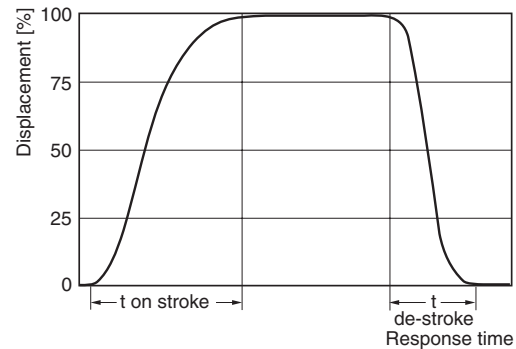

P3 Control schematics

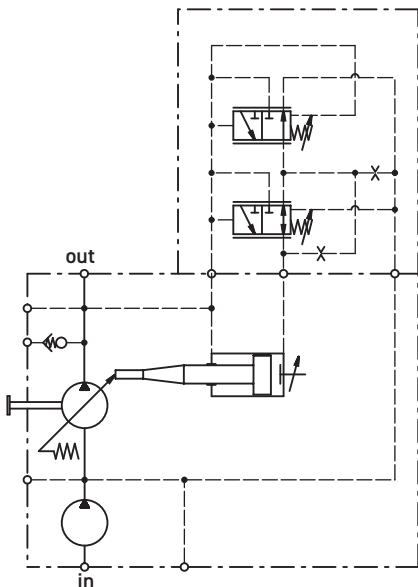

	t on stroke [ms]		t de-stroke [ms]
	against 50 bar	against 220 bar	zero stroke 280 bar
P2060	70	65	30
P2075	70	70	30
P2105 / P3105	120	90	30
P2145 / P3145	160	130	30

Compensator oil consumption PA control	max. 3.0 l/min
Pressure compensator adjusting range	Size 105 and 145 100 ... 350 bar
	Size 60 and 75 100 ... 320 bar
Hysteresis and repetitive accuracy	max. 3 bar

* Curve shown exaggerated

CONTROL OPTIONS “RA”

Remote pressure control

This control allows the pump pressure compensator setting to be adjusted from a remote relief valve. The control acts such that when full pump displacement is achieved the load pressure reaches the maximum setting of the remote relief valve. If pump flow is restricted by the system valve, the pump will provide only the flow demanded, but at the maximum pressure setting of the compensator control. If the outlet flow is completely blocked, the pump will de-stroke to zero displacement and maintain the pressure at the setting of the remote relief valve.

Response times of the pump are collected from a circuit as below by measuring the pumps swash angle movement at different pressures.

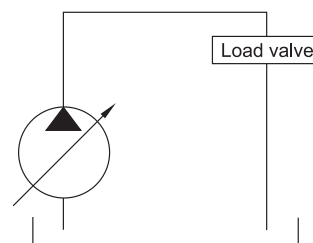

P2 Control schematics

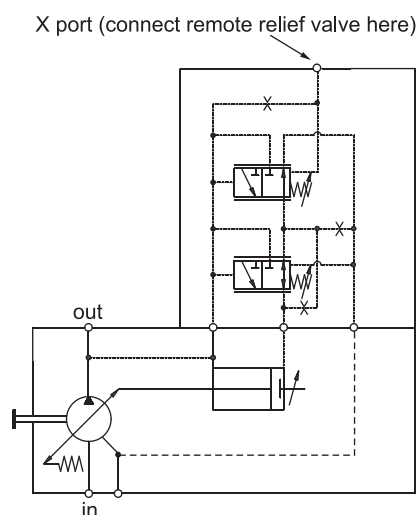

Dynamic characteristic of flow control *

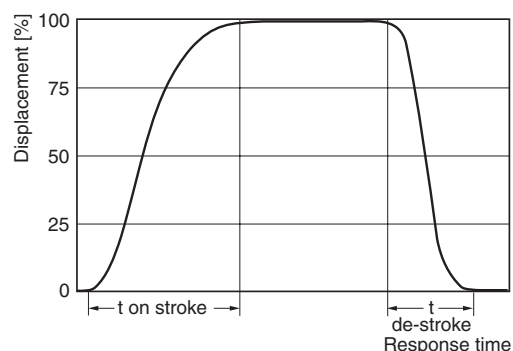

P3 Control schematics

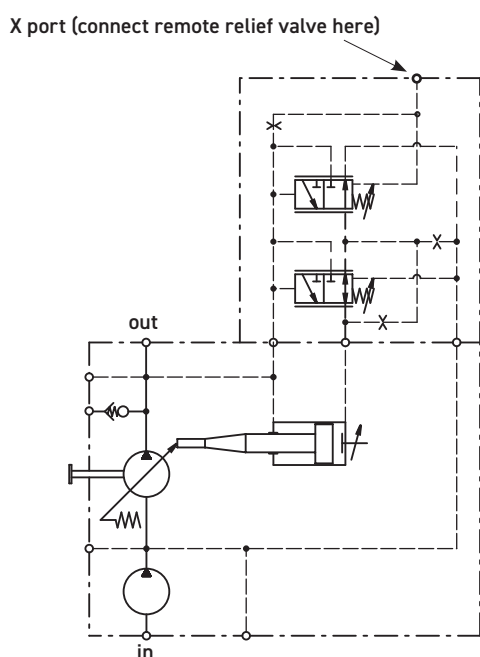

	t on stroke [ms]		t de-stroke [ms]	
	stand by to 250 bar	250 bar to stand by	250 bar to stand by	50 bar to stand by
P2060	60	30	30	40
P2075	80	35	35	40
P2105 / P3105	100	40	40	45
P2145 / P3145	120	45	45	50

Compensator oil consumption 'RA control	max. 3.0 l/min
Pilot pressure valve oil consumption	max. 2.0 l/min
Delta P compensator adjusting range	10 ... 35 bar
Pressure compensator adjusting range	Size 105 and 145 100 ... 350 bar
	Size 60 and 75 100 ... 320 bar
Hysteresis and repetitive accuracy	max. 3 bar

* Curve shown exaggerated

CONTROL OPTIONS "LA" AND "LB"

Load sensing control with maximum pressure control

These controls feature load sensing and maximum pressure compensation. Load sense controls are used to match pump flow to system demands.

P2 Control schematics

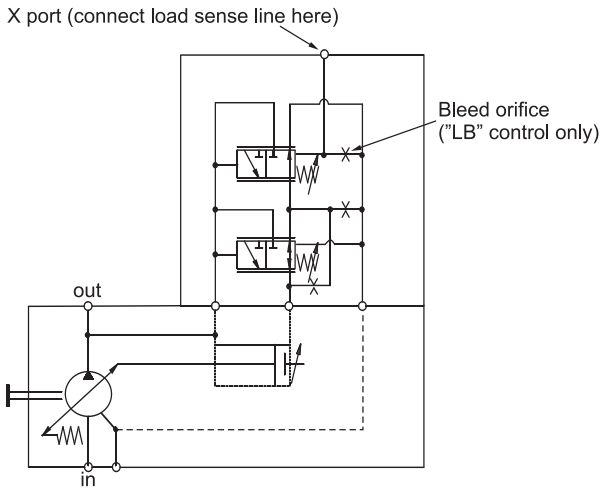

P3 Control schematics

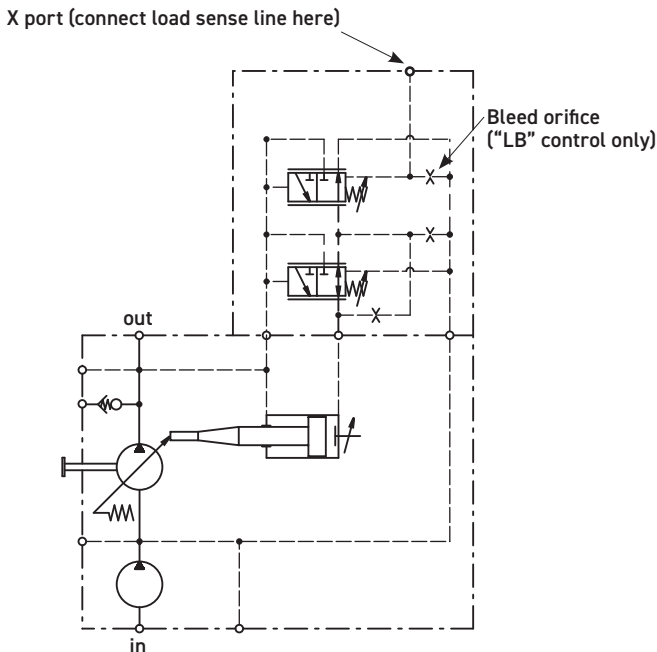

Response times of the pump are collected from a circuit as below by measuring the pumps swash angle movement at different pressures.

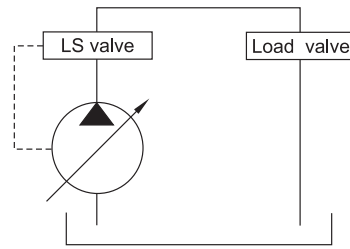

Dynamic characteristic of flow control *

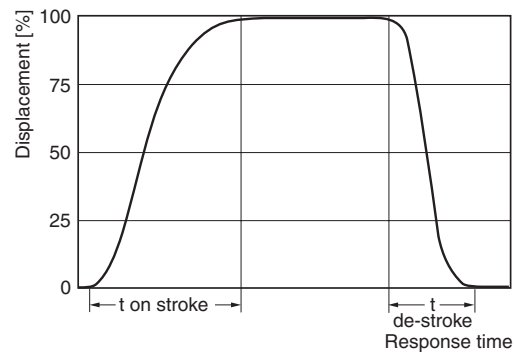

	t on stroke [ms]		t de-stroke [ms]	
	stand by to 250 bar	250 bar to stand by	250 bar to stand by	50 bar to stand by
P2060	60	30	30	40
P2075	80	35	35	40
P2105 / P3105	100	40	40	45
P2145 / P3145	120	45	45	50

Compensator oil consumption LA control	max. 3.0 l/min
Compensator oil consumption LB control	max. 4.5 l/min
Load sensing compensator adjusting range	10 ... 35 bar
Pressure compensator adjusting range	Size 105 and 145 100 ... 350 bar
	Size 60 and 75 100 ... 320 bar
Hysteresis and repetitive accuracy	max. 3 bar

* Curve shown exaggerated

Differential setting vs. stand-by pressure

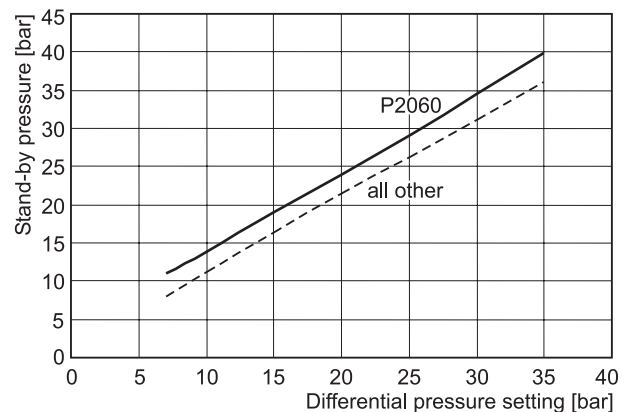

CONTROL OPTIONS “TA”, “TB”, “TC” AND “TD”

Torque limiting control with load sensing and maximum pressure control limiter

These controls provide the benefits of the load sensing and pressure limiting controls, plus the ability to limit the input torque the pump will draw. These controls are beneficial when the power available from the prime mover for the hydraulics is limited or the application power demand has both high flow/low pressure and low flow/high pressure duty cycles.

P2 Control schematics

X port (connect load sense line here)

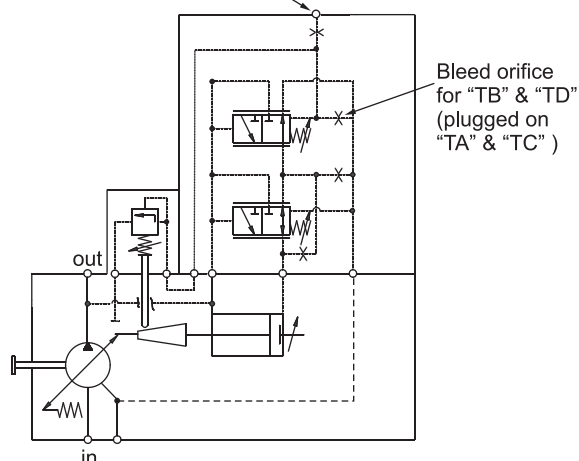

Dynamic characteristic of flow control *

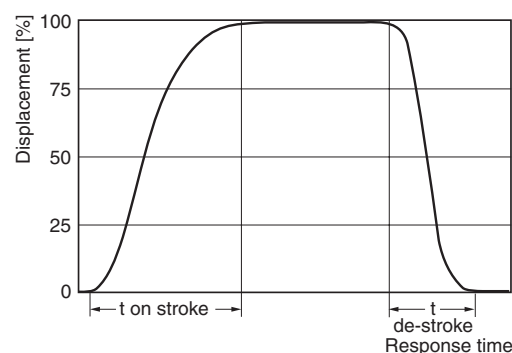

P3 Control schematics

X port (connect load sense line here)

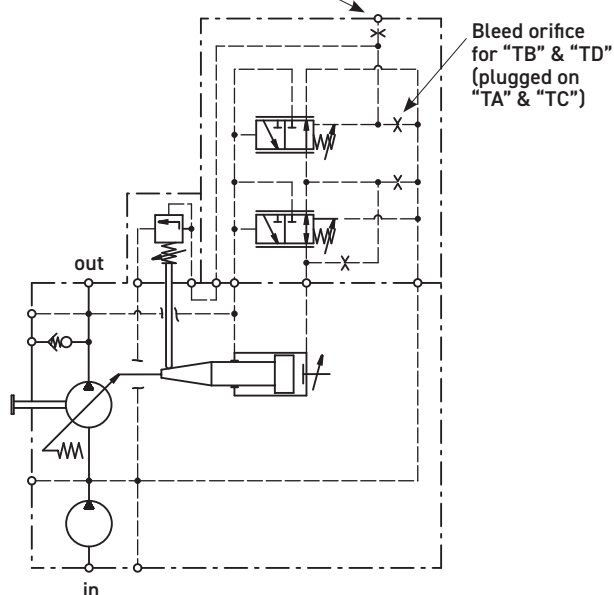

	t on stroke [ms]		t de-stroke [ms]	
	stand by to 250 bar	250 bar to stand by	250 bar to stand by	50 bar to stand by
P2060	60	30	30	40
P2075	80	35	35	40
P2105 / P3105	100	40	40	45
P2145 / P3145	120	45	45	50

Compensator oil consumption TA, TC control	max. 3.0 l/min
Compensator oil consumption TB, TD control	max. 4.5 l/min
Torque control valve oil consumption	max. 2.0 l/min
Load sensing compensator adjusting range	10 ... 35 bar
Pressure compensator adjusting range	Size 105 and 145 100 ... 350 bar
	Size 60 and 75 100 ... 320 bar
Hysteresis and repetitive accuracy	max. 3 bar

* Curve shown exaggerated

Response times of the pump are collected from a circuit as below by measuring the pumps swash angle movement at different pressures.

P2 TYPICAL TORQUE CONTROL CHARACTERISTICS

P2060 - 20...60 % Torque (1800 rpm)

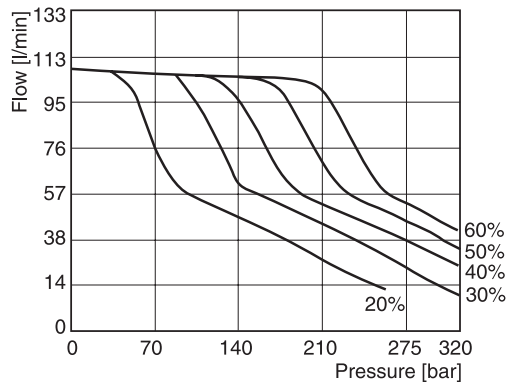

P2060 - 50...90 % Torque (1800 rpm)

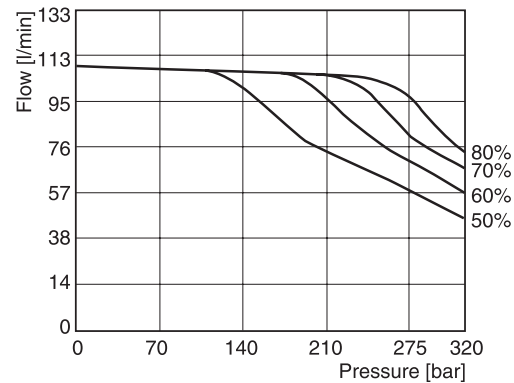

P2075 - 20...60 % Torque (1800 rpm)

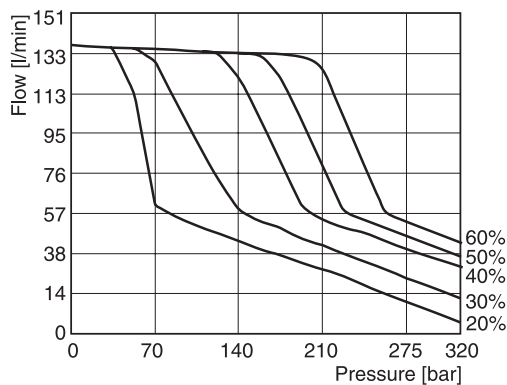

P2075 - 50...90 % Torque (1800 rpm)

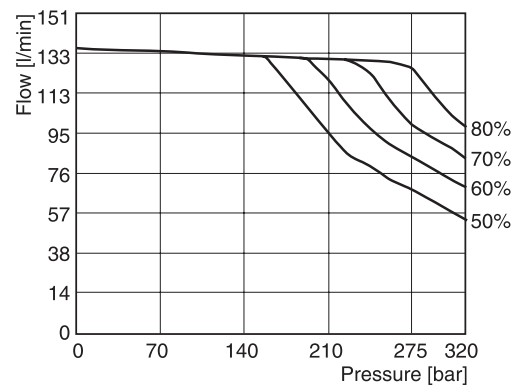

P2105 - 20...60 % Torque (1800 rpm)

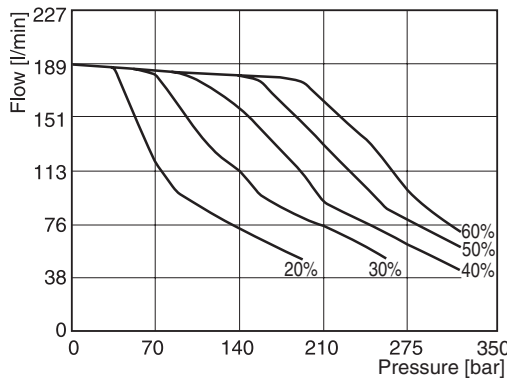

P2105 - 50...90 % Torque (1800 rpm)

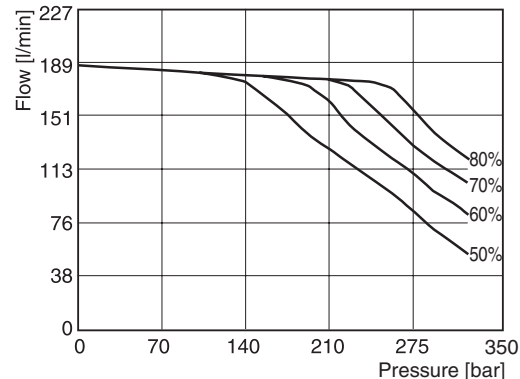

P2145 - 20...60 % Torque (1800 rpm)

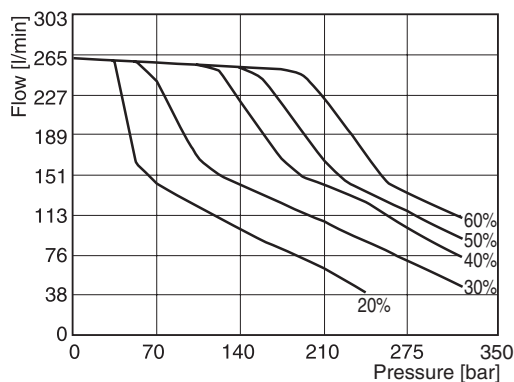

P2145 - 50...90 % Torque (1800 rpm)

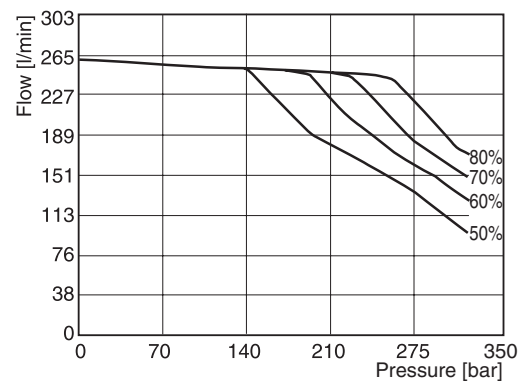

Fluid: Mineral oil ISO VG 32 at 40°C ; Inlet pressure: 1.0 bar (absolute) measured at inlet port.

P3 TYPICAL TORQUE CONTROL CHARACTERISTICS

P3105 - 20...60 % Torque (1800 rpm)

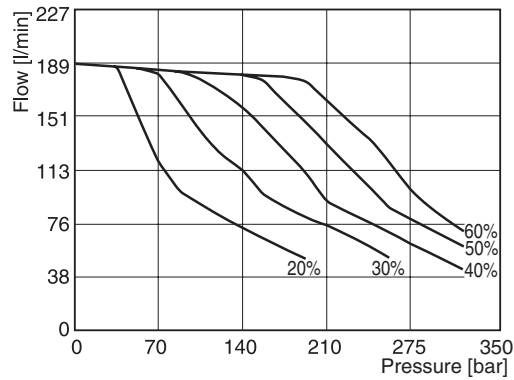

P3105 - 50...90 % Torque (1800 rpm)

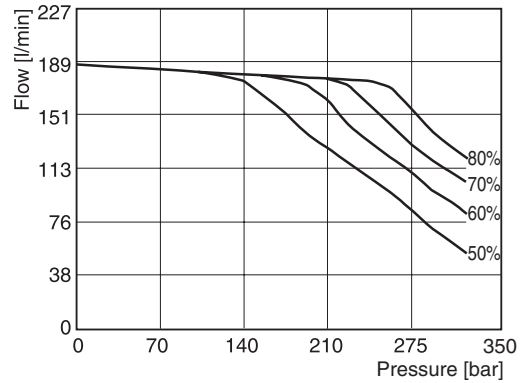

P3145 - 20...60 % Torque (1800 rpm)

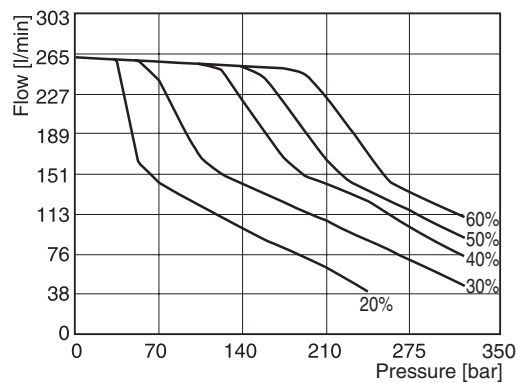

P3145 - 50...90 % Torque (1800 rpm)

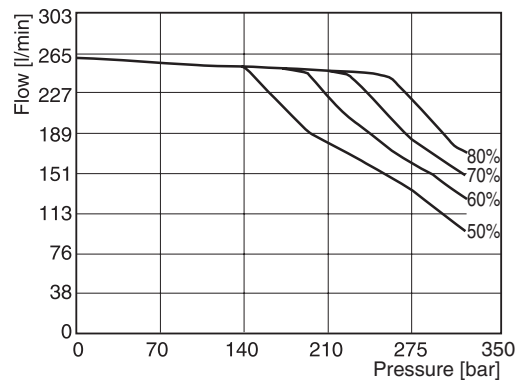

Fluid: Mineral oil ISO VG 32 at 40°C ; Inlet pressure: 1.0 bar (absolute) measured at inlet port.

HYDR. GENERATED NOISE / PERFORMANCE CURVES

Ripple chamber

Pressure ripple at 200 bar

The chart on the right refers to the "Ripple Chamber" technology engineered into the P2 and P3 series pumps. The ripple chamber reduces flow pulsation and due to this pressure pulsation (called "ripple") at the outlet of the pump. This technology reduces the ripple by 40–60% and leads to a significant reduction in overall system noise without additional components or cost.

The ripple chamber is standard on all P2 and P3 series side ported pumps.

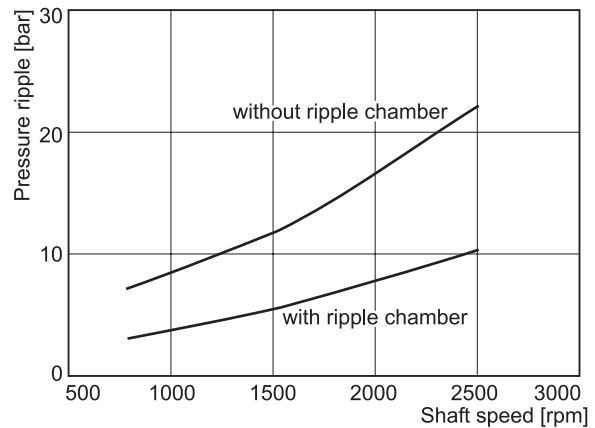

P2 Noise characteristics at max./min. displacement

P2060 Noise characteristics

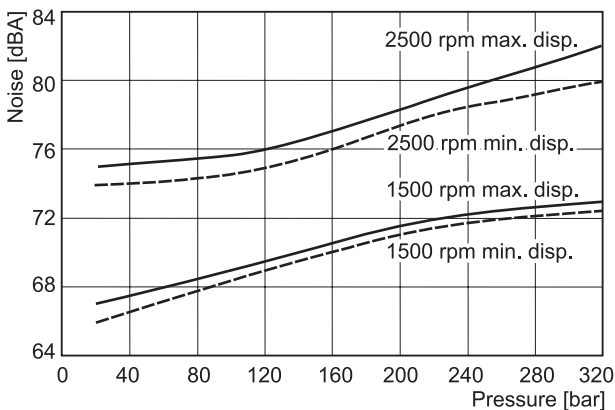

P2075 Noise characteristics

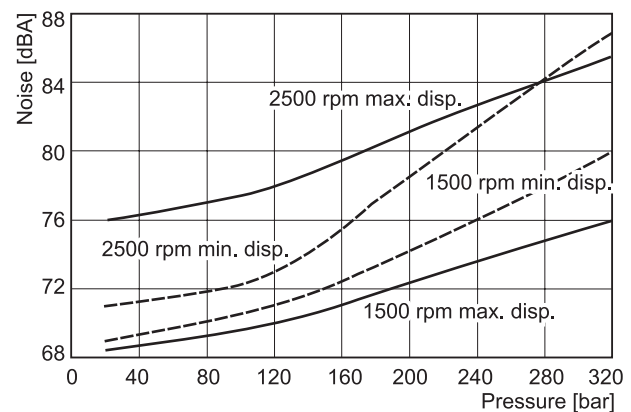

P2105 Noise characteristics

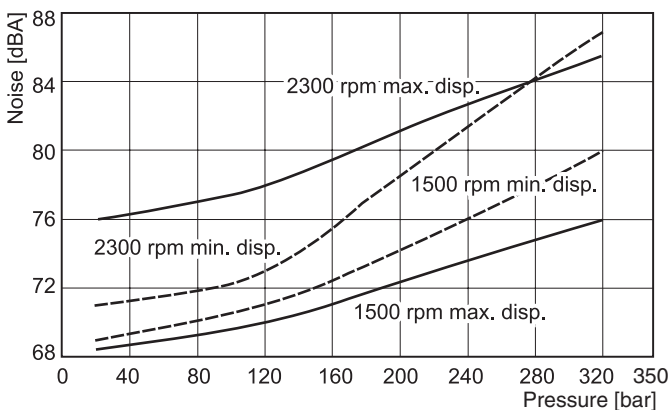

P2145 Noise characteristics

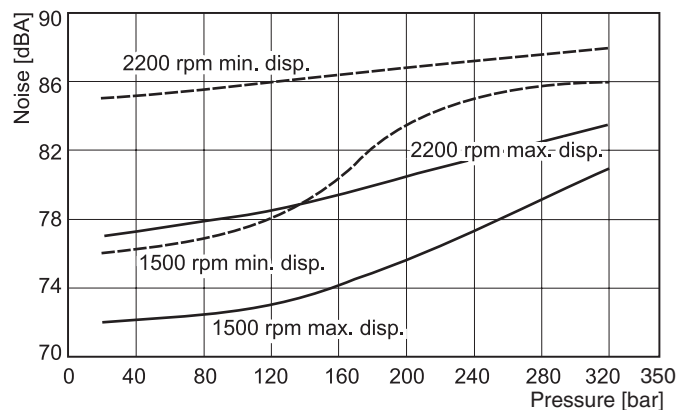

PERFORMANCE CURVES P2

P2 Series - typical drive power at full displacement

P2060 Input power - full stroke

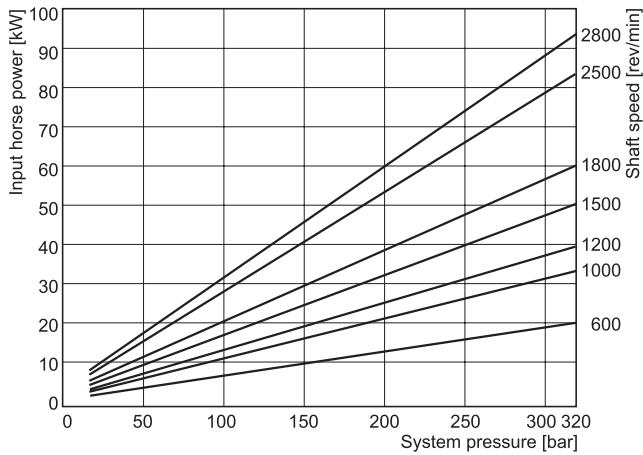

P2075 Input power - full stroke

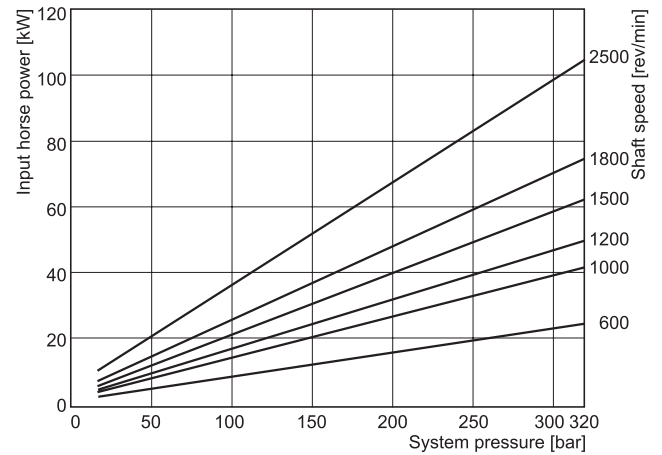

P2105 Input power - full stroke

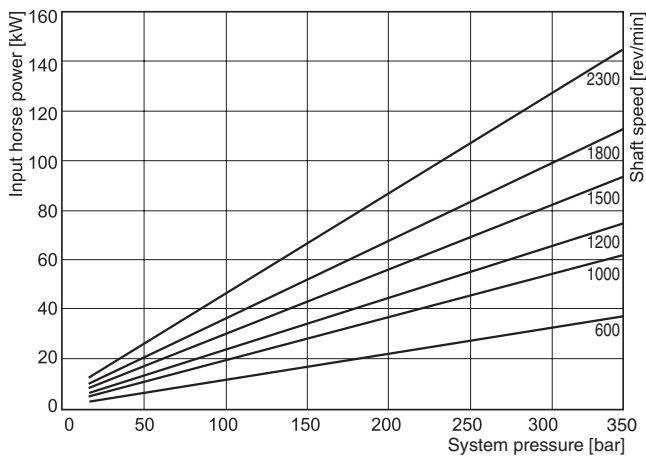

P2145 Input power - full stroke

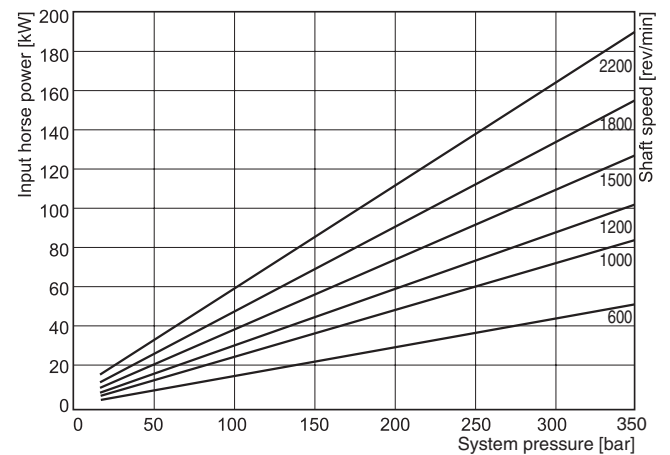

Fluid: Mineral oil ISO VG 32 at 40°C ; Inlet pressure: 1.0 bar (absolute) measured at inlet port.

P2 Series - typical compensated input power

P2060 Input power - zero stroke

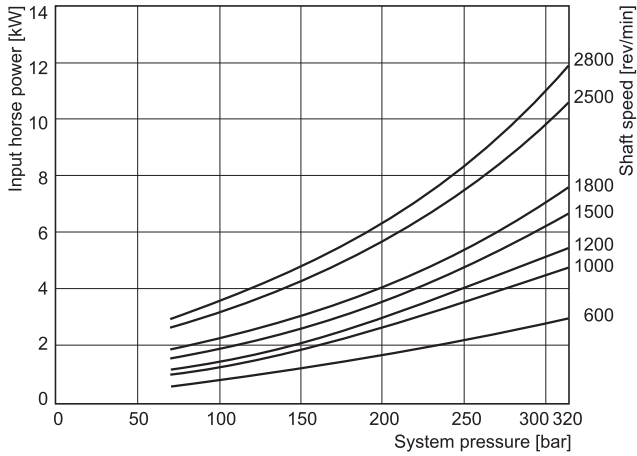

P2075 Input power - zero stroke

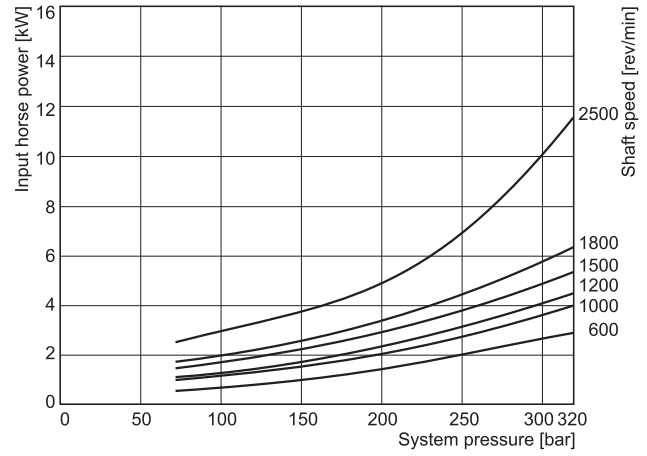

P2105 Input power - zero stroke

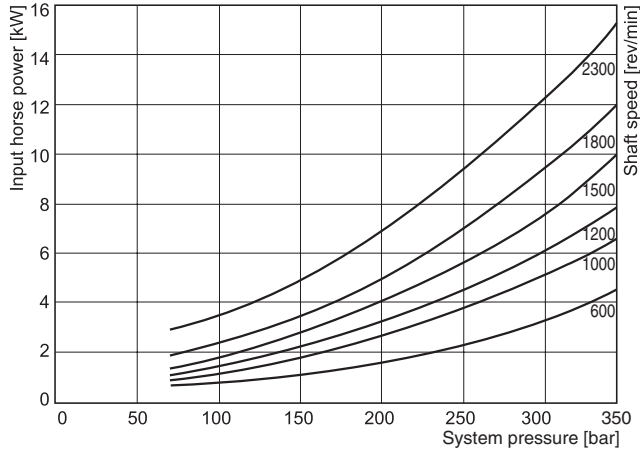

P2145 Input power - zero stroke

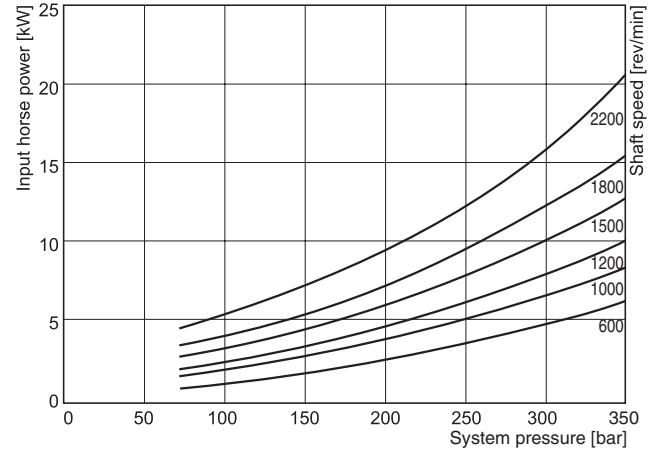

Fluid: Mineral oil ISO VG 32 at 40°C ; Inlet pressure: 1.0 bar (absolute) measured at inlet port.

P2 Series - typical efficiency at full displacement at 1800 rpm

P2060 Efficiency at 1800 rpm

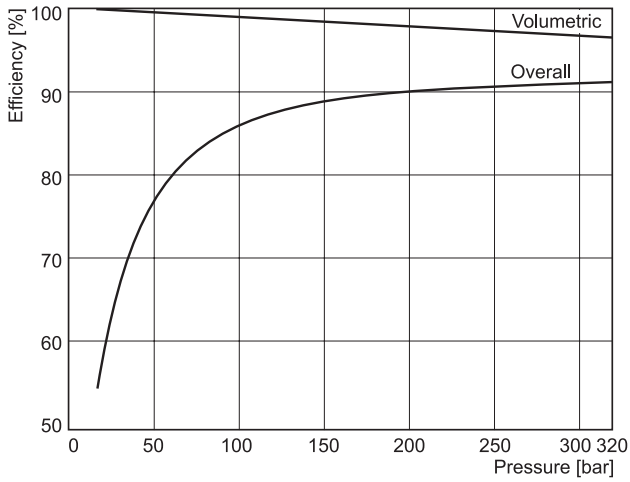

P2075 Efficiency at 1800 rpm

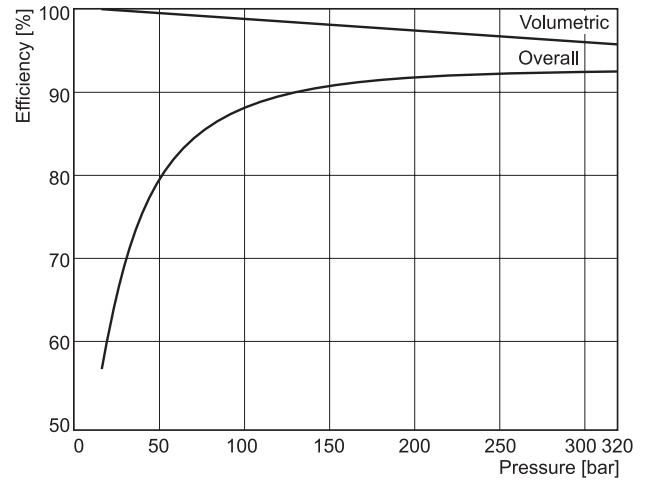

P2105 Efficiency at 1800 rpm

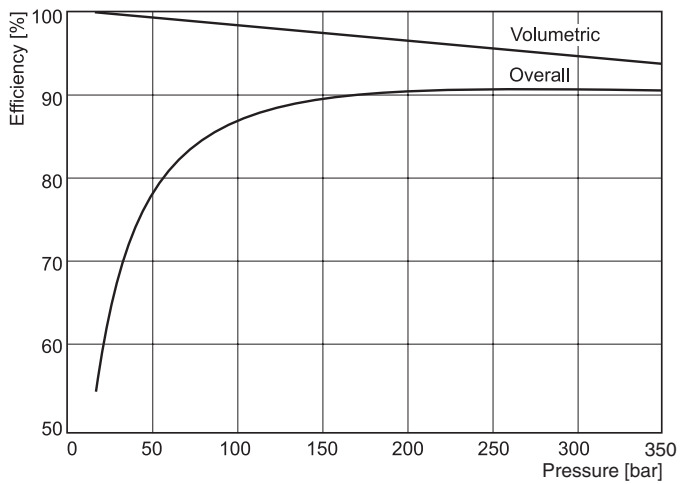

P2145 Efficiency at 1800 rpm

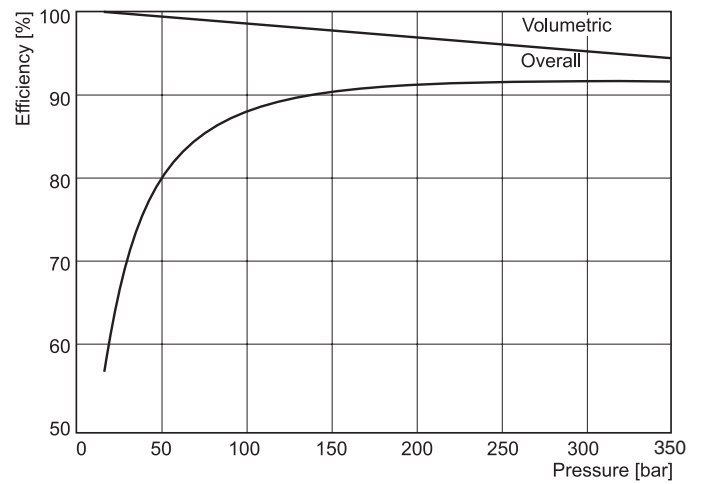

Fluid: Mineral oil ISO VG 32 at 40°C ; Inlet pressure: 1.0 bar (absolute) measured at inlet port.

P2 Series - typical flow vs. pressure

P2060 Outlet flow - full stroke

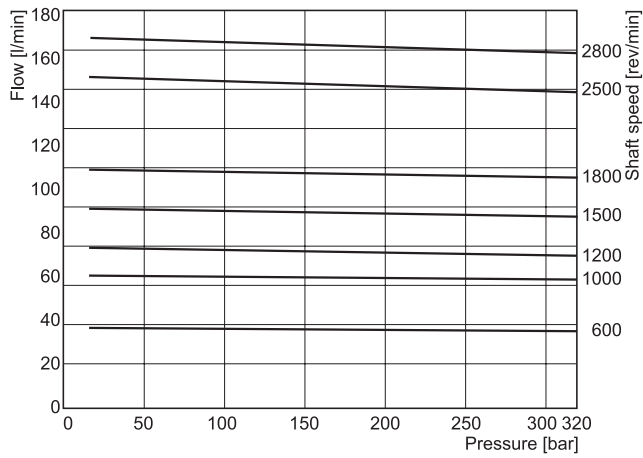

P2075 Outlet flow - full stroke

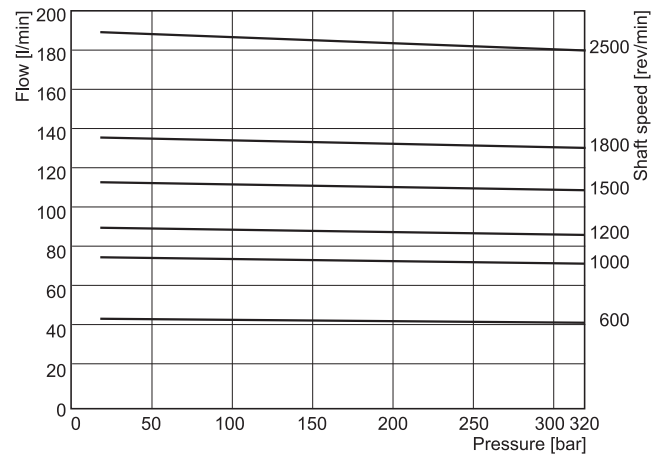

P2105 Outlet flow - full stroke

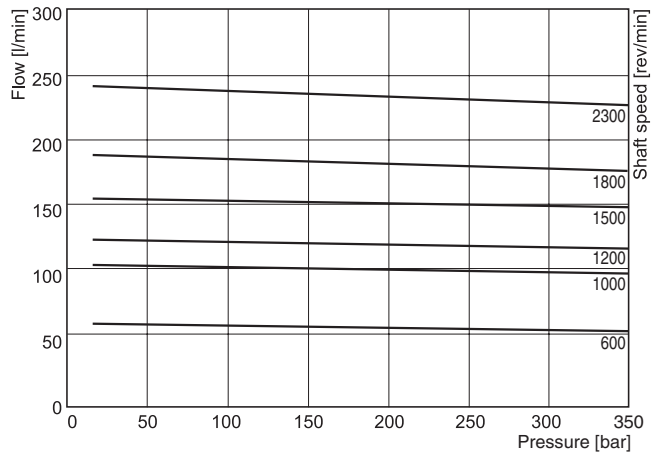

P2145 Outlet flow - full stroke

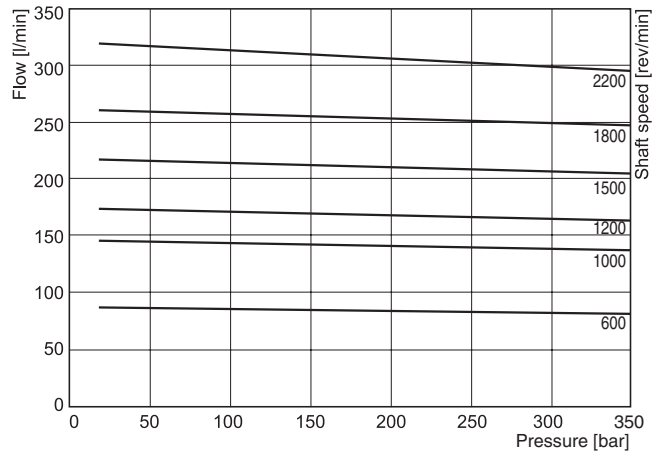

Fluid: Mineral oil ISO VG 32 at 40°C ; Inlet pressure: 1.0 bar (absolute) measured at inlet port.

P2 Series - typical compensated case drain flow

P2060 Drain flow at zero stroke

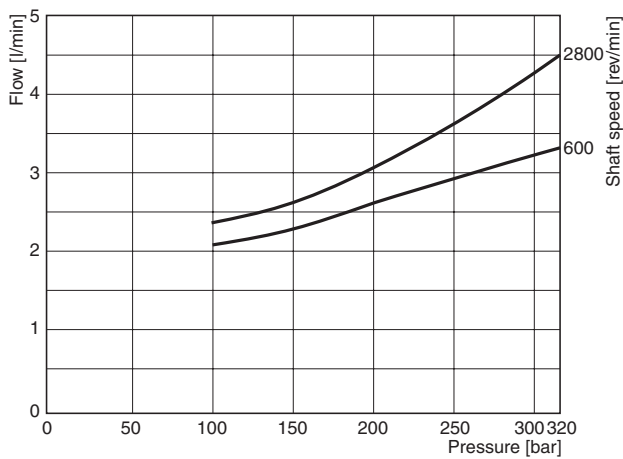

P2075 Drain flow at zero stroke

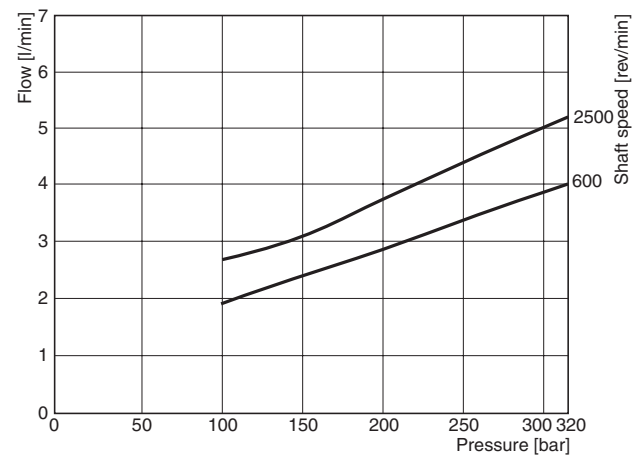

P2105 Drain flow at zero stroke

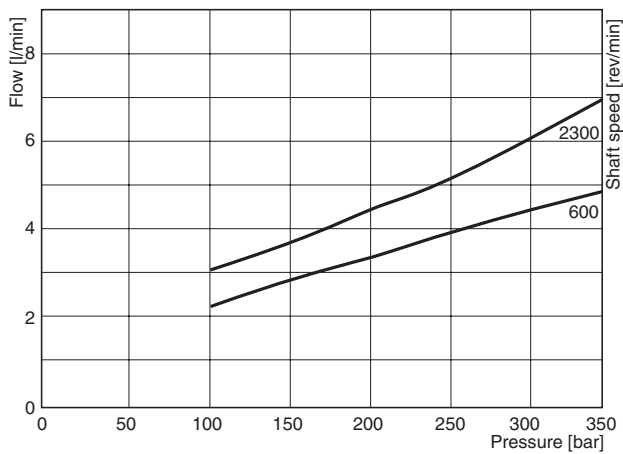

P2145 Drain flow at zero stroke

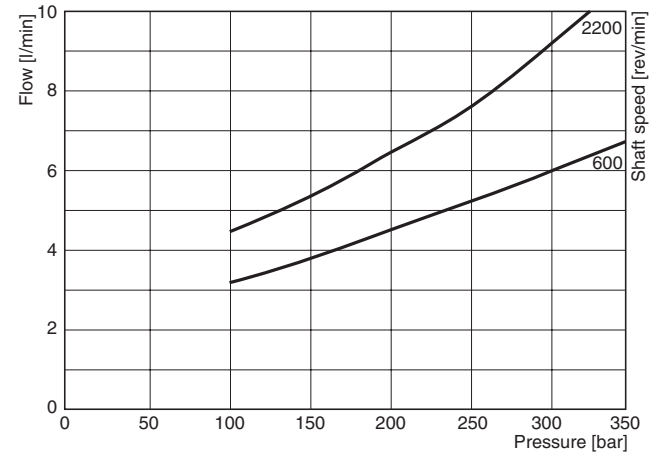

Fluid: Mineral oil ISO VG 32 at 40°C ; Inlet pressure: 1.0 bar (absolute) measured at inlet port.

P2 Series - typical inlet characteristics vs. speed at various percentage displacements

P2060 Inlet characteristics

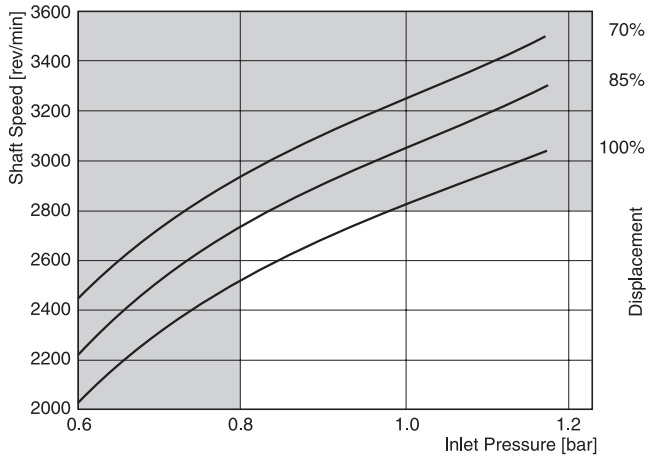

P2075 Inlet characteristics

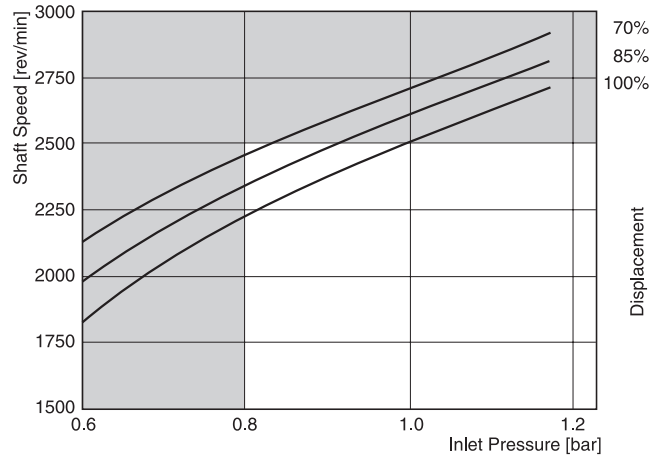

P2105 Inlet characteristics

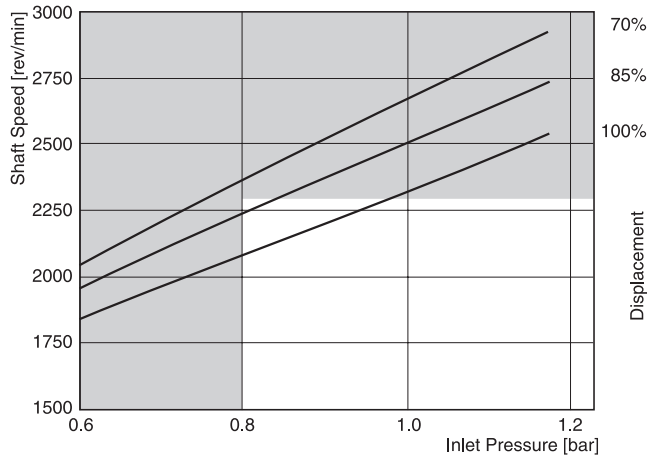

P2145 Inlet characteristics

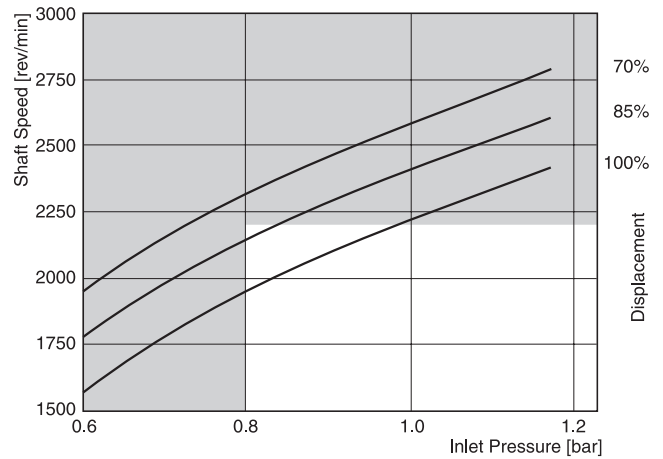

Fluid: Mineral oil ISO VG 32 at 40°C ; Inlet pressure: 1.0 bar (absolute) measured at inlet port.



For operation at these conditions, please consult manufacturer for approval.

DIMENSIONS P2

P2060 Mounting flange

SAE B 2-bolt mounting flange

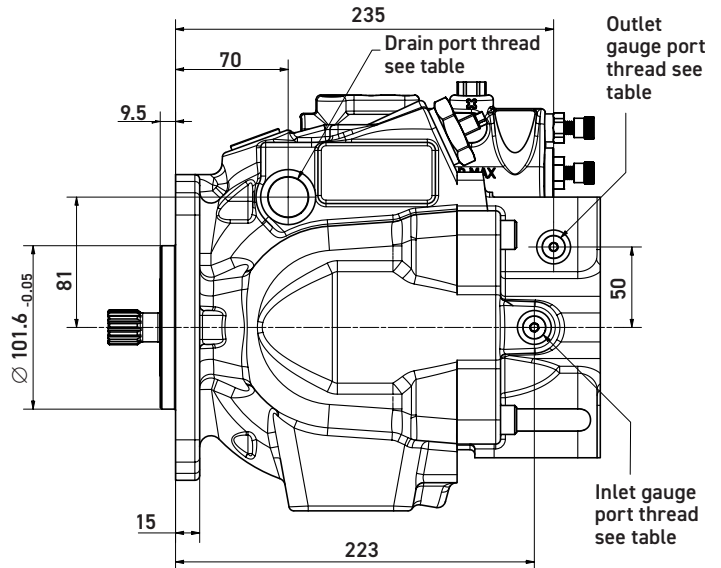
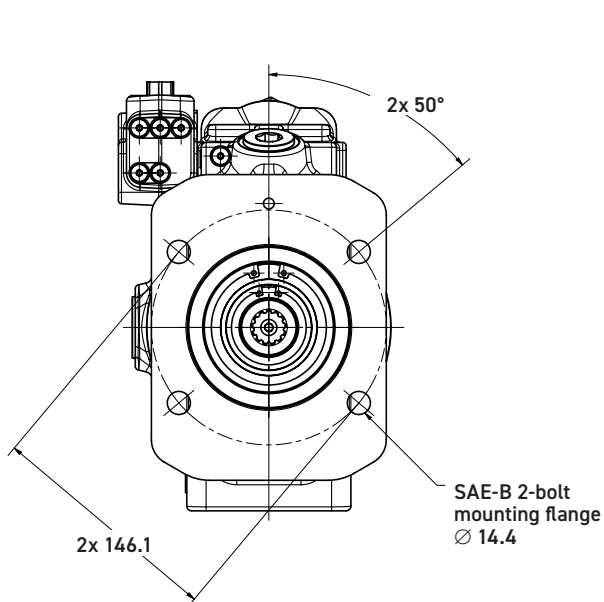

SAE C 4-bolt mounting flange

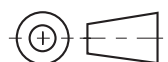
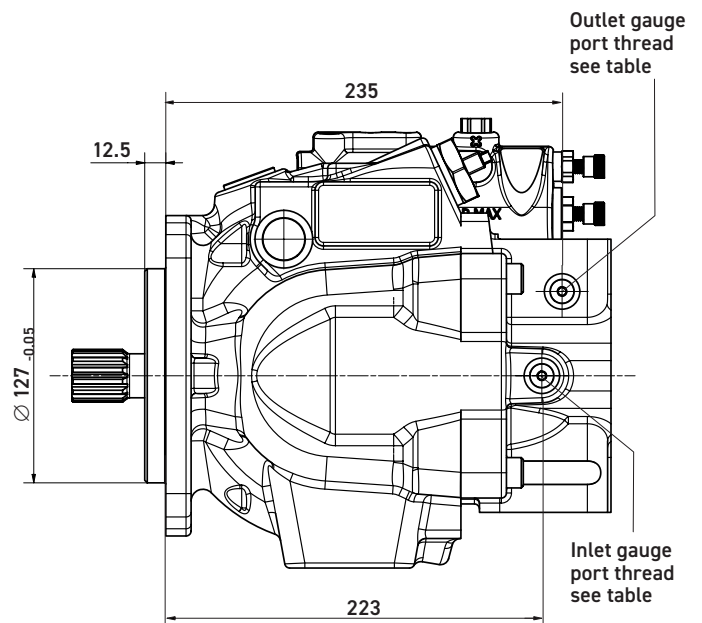
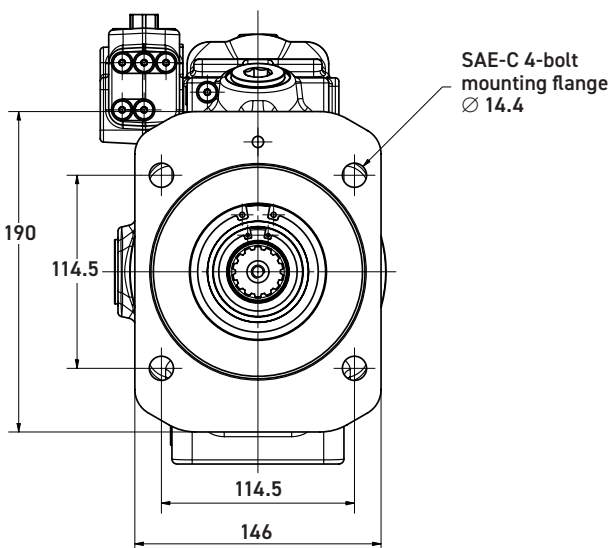

CW pump shown.

CCW pump will have inlet and outlet gauge ports opposite side.

Port ordering code	Drain port	Inlet gauge port / Outlet gauge port / Signal port
"A" side - UNC	SAE-10 straight thread / O-ring port: 7/8-14 UN thread	SAE-4 straight thread / O-ring port: 7/16-20 UN thread
"B" side - metric	ISO 6149 straight thread / O-ring port: M22 x 1.5 thread	ISO 6149 straight thread / O-ring port: M12 x 1.5 thread

P2060 Side port

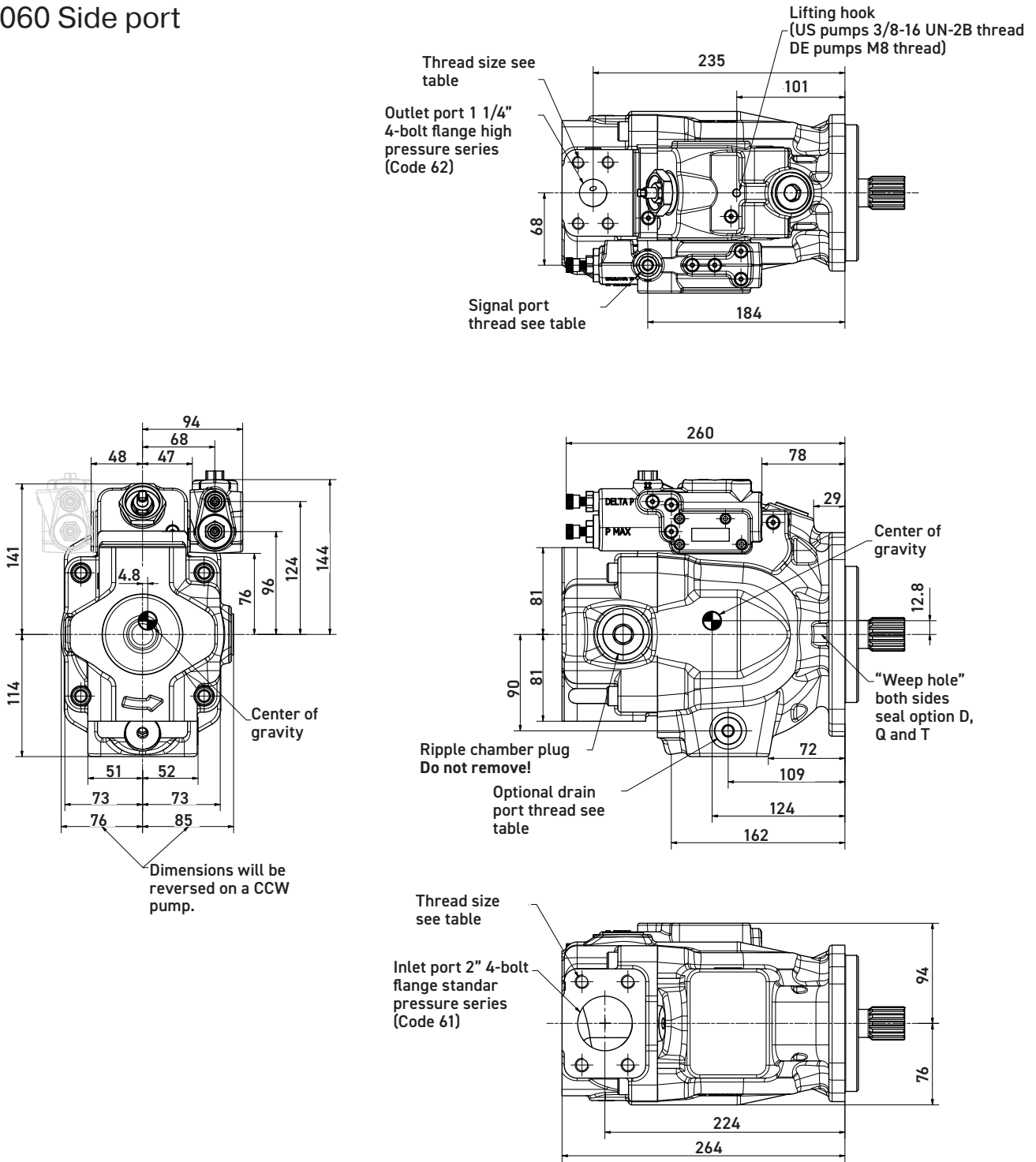

Pump shown is a CW rotation P2060 series pump with load sense and max. pressure compensator.

As an option the compensator unit can be positioned at opposite side of the pump. Please consult manufacturer for details.

CCW pump will have inlet and outlet gauge ports opposite side.

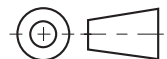

Port option	Drain port	Inlet port	Outlet port	Inlet gauge port / Outlet gauge port / Signal port
"A" side - UNC	SAE-10 straight thread / O-ring port: 7/8-14 UN thread	1/2-13 UN	7/16-14 UN	SAE-4 straight thread / O-ring port: 7/16-20 UN thread
"B" side - metric	ISO 6149 straight thread / O-ring port: M22 x 1.5 thread	M12 x 1.75	M12 x 1.75	ISO 6149 straight thread / O-ring port: M12 x 1.5 thread

P2060 Thru-drive option

A1 configuration

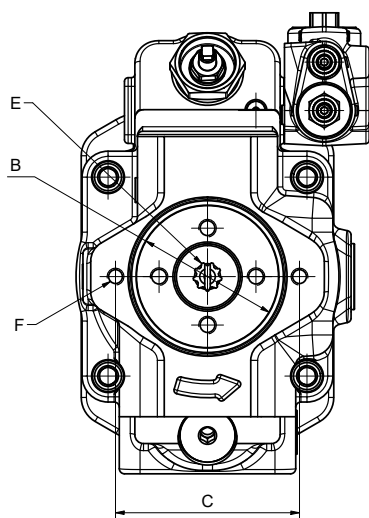

B1 and B2 configurations

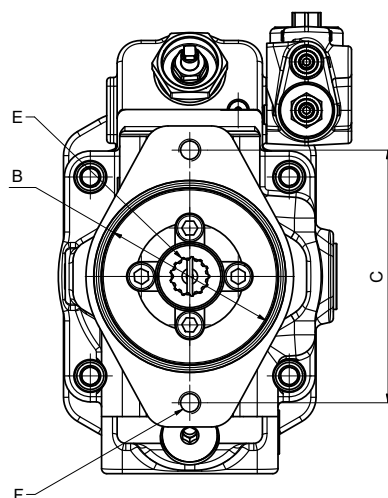

C3 and C4 configurations

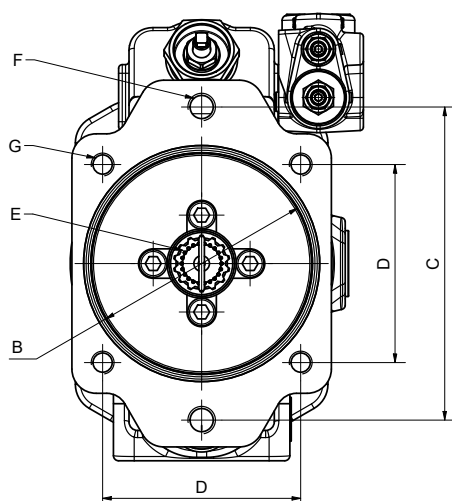

P2060 partial cut-away of thru-drive area

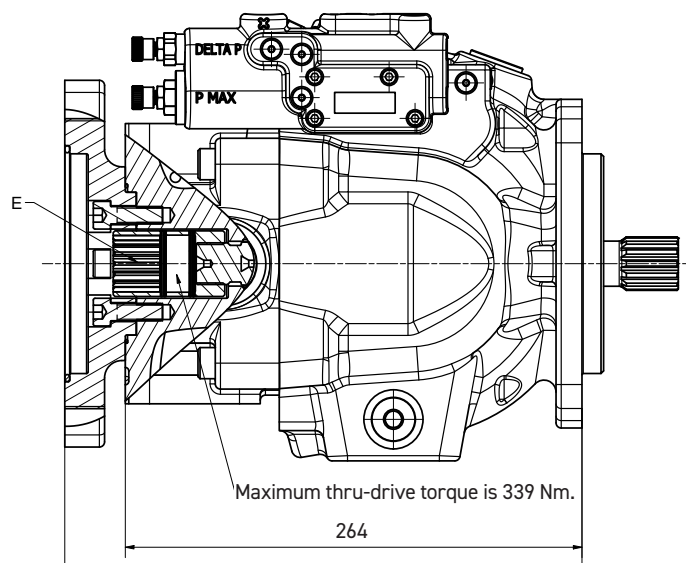

Thru-shaft option	A	B Ø	C	D	E	F UNC	F metric	G UNC	G metric	Weight
A1	264	82.625 82.575	106.38	N/A	SAE-A spline 9 tooth 16/32 pitch	3/8-16 UNC-2B THD	M10 x 1.5 THD	N/A	N/A	36.2 kg
B1	297	101.676 101.625	146.05	N/A	SAE-B spline 13 tooth 16/32 pitch	1/2-13 UNC-2B THD	M12 x 1.75 THD	N/A	N/A	38.9 kg
B2	297	101.676 101.625	146.05	N/A	SAE-BB spline 15 tooth 16/32 pitch	1/2-13 UNC-2B THD	M12 x 1.75 THD	N/A	N/A	38.9 kg
C3/C4	299	127.076 127.025	180.98	114.5	SAE-C spline 14 tooth 12/24 pitch	5/8-11 UNC-2B THD	M16 x 2 THD	1/2-13 UNC-2B THD	M12 x 1.75 THD	40.2 kg

P2075 Mounting flange

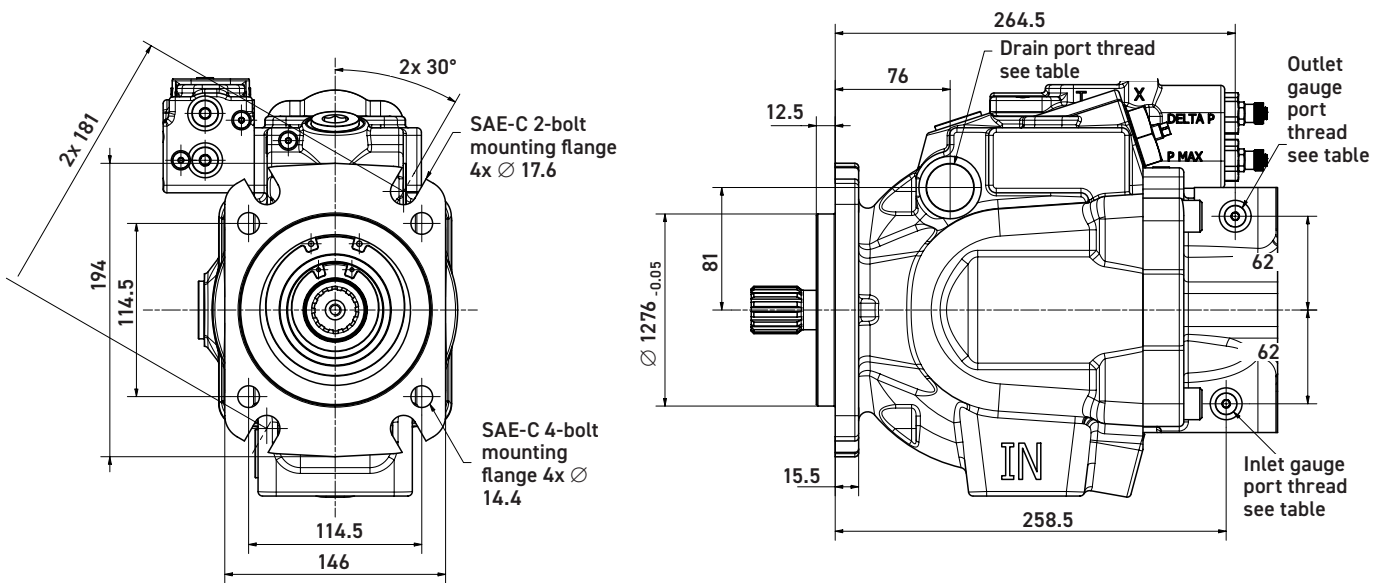

CW pump shown.
CCW pump will have inlet and outlet gauge ports reversed.



Port ordering code	Drain port	Inlet gauge port / Outlet gauge port
"A" side - UNC	SAE-12 straight thread / O-ring port: 1-1/16-12 UN thread	SAE-4 straight thread / O-ring port: 7/16-20 UN thread
"B" side - metric	ISO 6149 straight thread / O-ring port: M27 x 2 thread	ISO 6149 straight thread / O-ring port: M12 x 1.5 thread

P2075 Side port

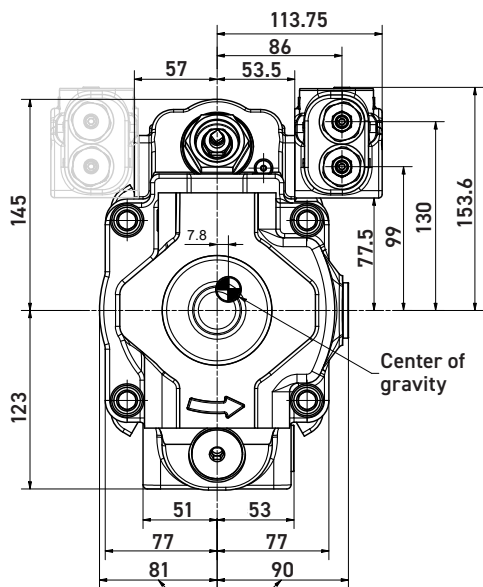
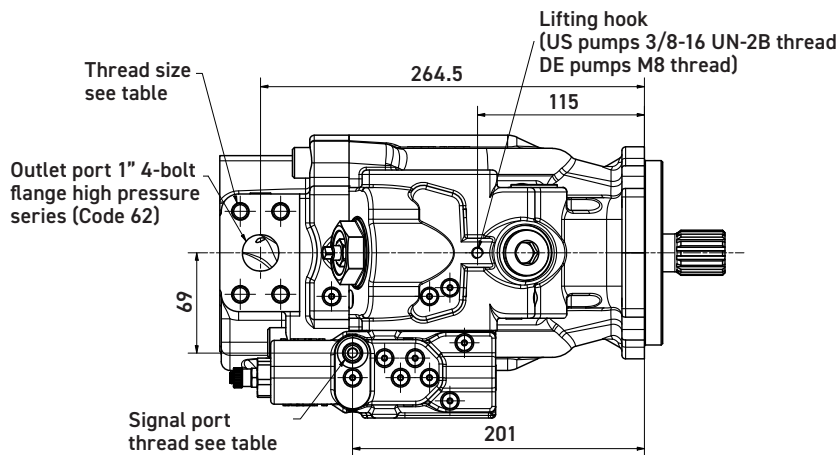

Dimensions will be reversed on a CCW pump.

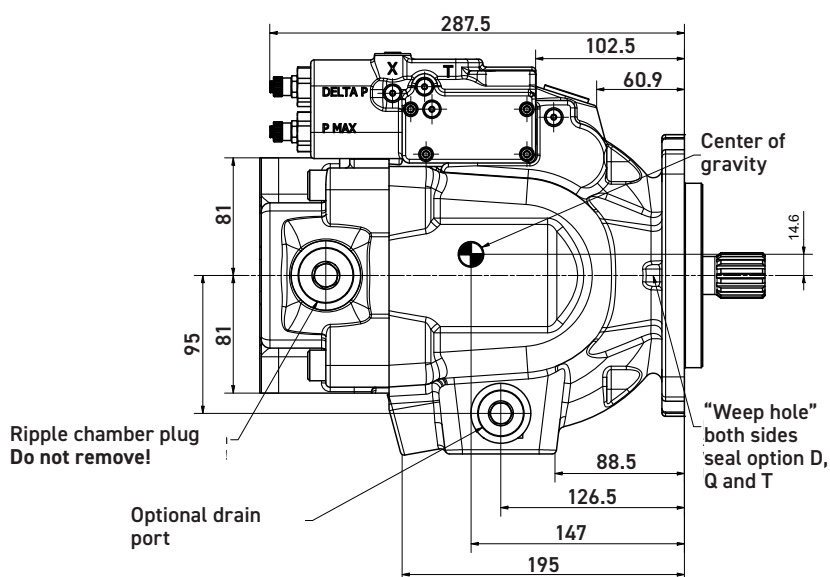

Thread size see table

Inlet port 2" 4-bolt flange standar pressure series (Code 61)

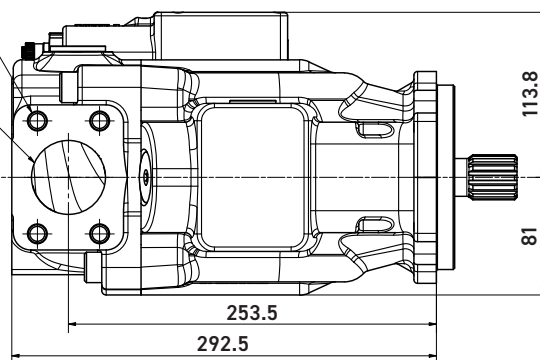

Pump shown is a CW rotation P2075 series pump with load sense and max. pressure compensator.

As an option the compensator unit can be positioned at opposite side of the pump. Please consult manufacturer for details.

CCW pump will have inlet and outlet gauge ports opposite side.

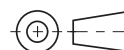

Port option	Drain port	Inlet port	Outlet port	Inlet gauge port / Outlet gauge port / Signal port
"A" side - UNC	SAE-12 straight thread / O-ring port: 1-1/16-12 thread	1/2-13 UN	7/16-14 UN	SAE-4 straight thread / O-ring port: 7/16-20 UN thread
"B" side - metric	ISO 6149 straight thread / O-ring port: M27 x 2 thread	M12 x 1.75	M12 x 1.75	ISO 6149 straight thread / O-ring port: M12 x 1.5 thread

P2075 Thru-drive option

A1 configuration

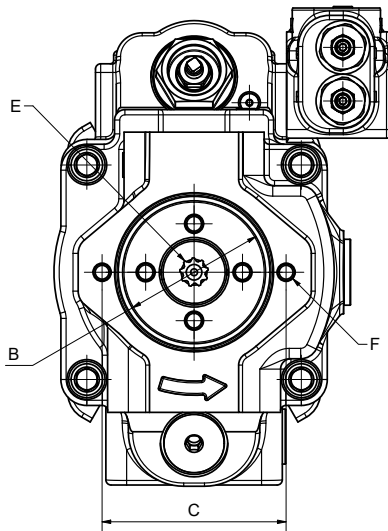

B1 and B2 configurations

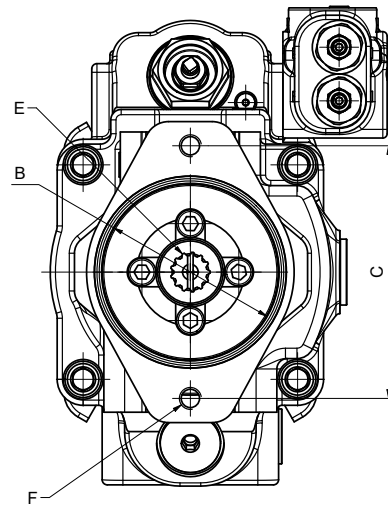

C1 and C3 configurations

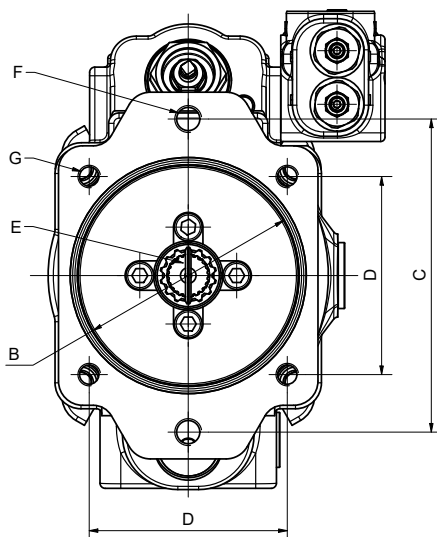

P2075 partial cut-away of thru-drive area

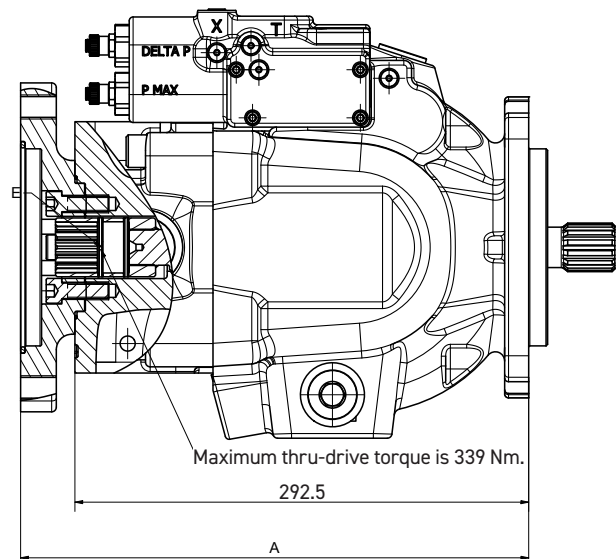

Pumps will be assembled with flange adapters as shown. Options B1, B2, C1 and C3 can be rotated 90°.

Thru-shaft option	A	B Ø	C	D	E	F UNC	F metric	G UNC	G metric	Weight
A1	292.5	82.625 82.575	106.38	N/A	SAE-A spline 9 tooth 16/32 pitch	3/8-16 UNC-2B THD	M10 x 1.5 THD	N/A	N/A	44 kg
B1	325.5	101.676 101.625	146.05	N/A	SAE-B spline 13 tooth 16/32 pitch	1/2-13 UNC-2B THD	M12 x 1.75 THD	N/A	N/A	46.5 kg
B2	325.5	101.676 101.625	146.05	N/A	SAE-BB spline 15 tooth 16/32 pitch	1/2-13 UNC-2B THD	M12 x 1.75 THD	N/A	N/A	46.5 kg
C1 C3	327.5	127.076 127.025	180.98	114.5	SAE-C spline 14 tooth 12/24 pitch	5/8-11 UNC-2B THD	M16 x 2 THD	1/2-13 UNC-2B THD	M12 x 1.75 THD	48 kg

P2105 Mounting flange

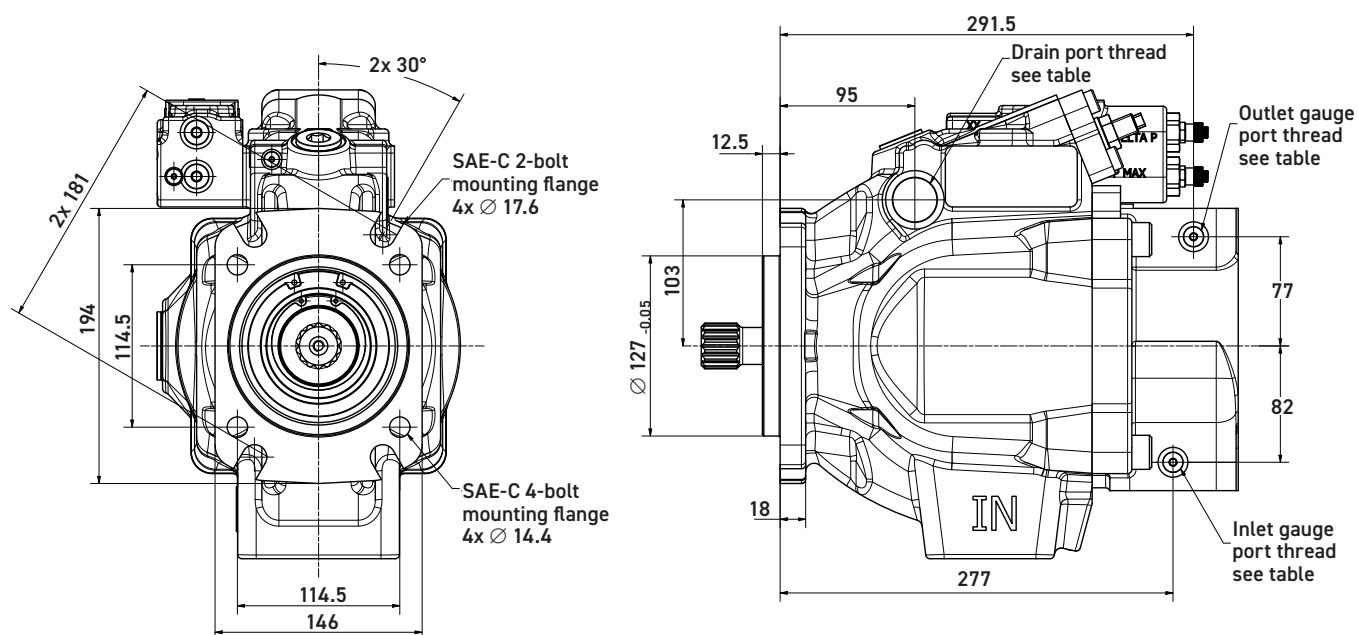

CW pump shown.

CCW pump will have inlet and outlet gauge ports opposite side.



Port ordering code	Drain port	Inlet gauge port / Outlet gauge port
"A" side - UNC	SAE-12 straight thread / O-ring port: 1-1/16-12 UN thread	SAE-4 straight thread / O-ring port: 7/16-20 UN thread
"B" side - metric	ISO 6149 straight thread / O-ring port: M27 x 2 thread	ISO 6149 straight thread / O-ring port: M12 x 1.5 thread

P2105 Side port

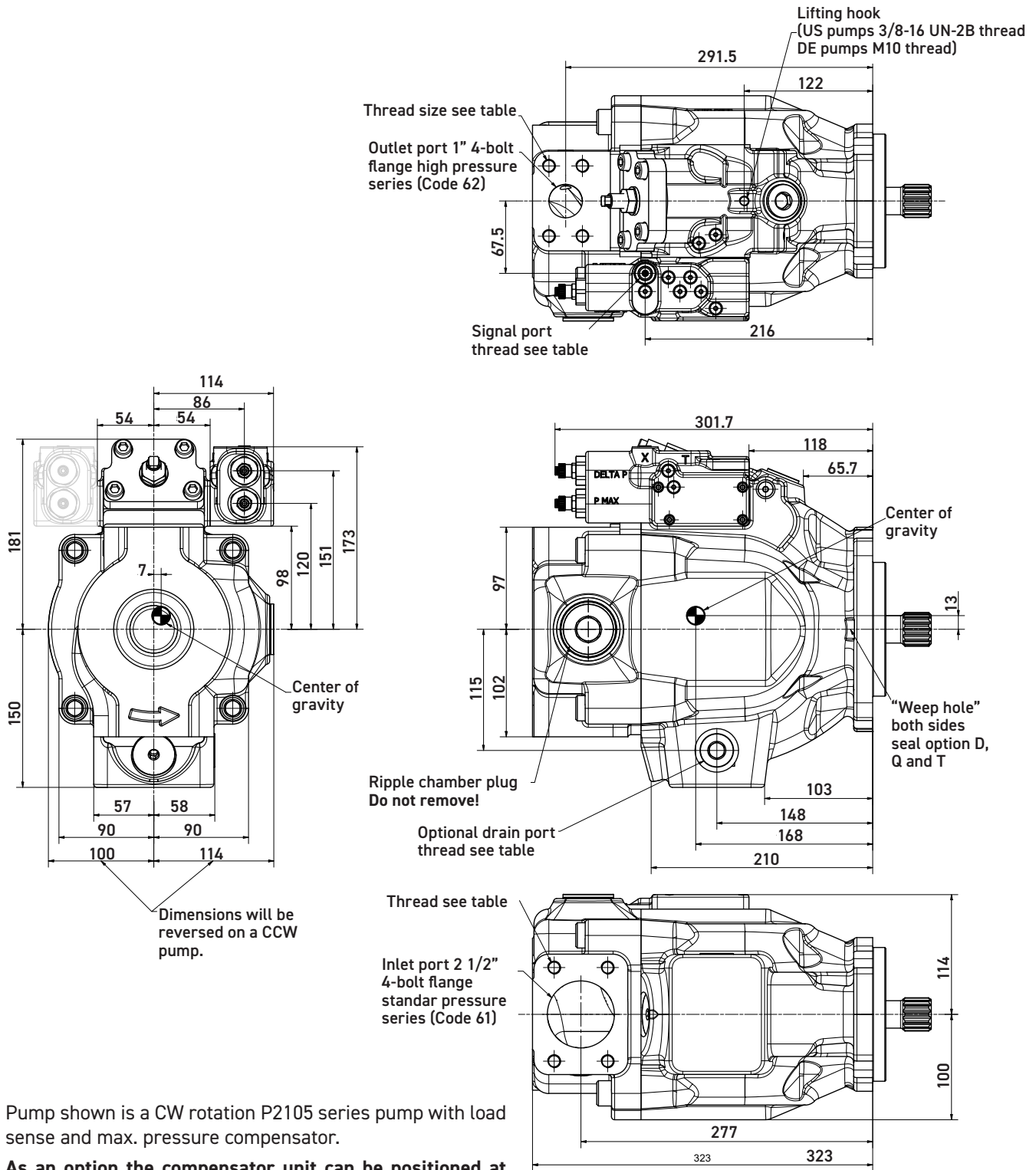

Pump shown is a CW rotation P2105 series pump with load sense and max. pressure compensator.

As an option the compensator unit can be positioned at opposite side of the pump. Please consult manufacturer for details.

CCW pump will have inlet and outlet gauge ports opposite side.

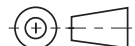

Port option	Drain port	Inlet port	Outlet port	Inlet gauge port / Outlet gauge port / Signal port
"A" side - UNC	SAE-12 straight thread / O-ring port: 1-1/16-12 thread	1/2-13 UN	1/2-13 UN	SAE-4 straight thread / O-ring port: 7/16-20 UN thread
"B" side - metric	ISO 6149 straight thread / O-ring port: M27 x 2 thread	M12 x 1.75	M12 x 1.75	ISO 6149 straight thread / O-ring port: M12 x 1.5 thread

P2105 Thru-drive option

A1 configuration

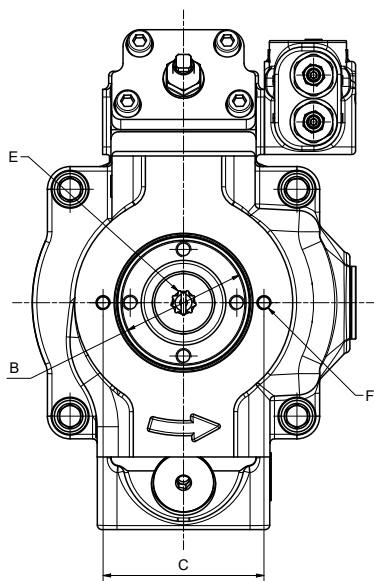

B1 and B2 configurations

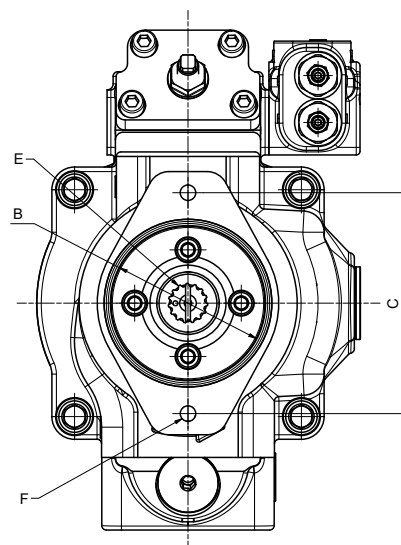

C1 and C3 configurations

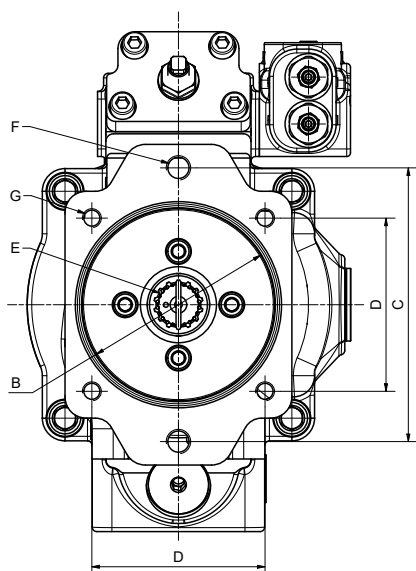

P2105 partial cut-away of thru-drive area

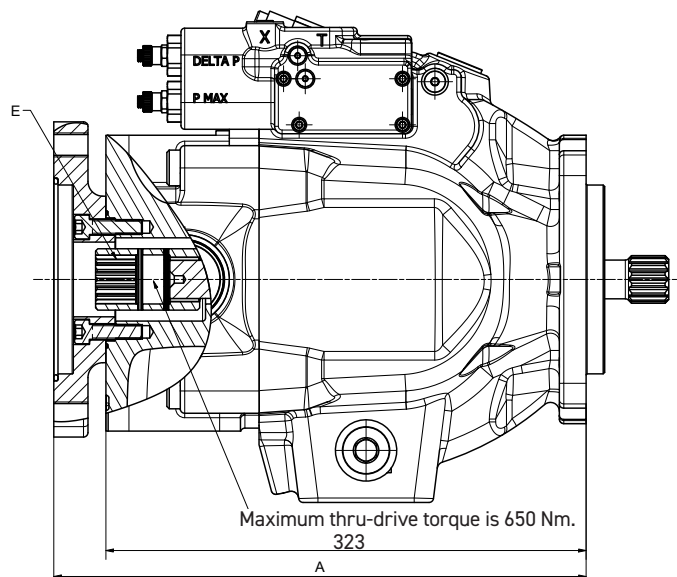

Pumps will be assembled with flange adapters as shown. Options B1, B2, C1 and C3 can be rotated 90°.

Thru-shaft option	A	B ∅	C	D	E	F UNC	F metric	G UNC	G metric	Weight
A1	323	82.625 82.575	106.38	N/A	SAE-A spline 9 tooth 16/32 pitch	3/8-16 UNC-2B THD	M10 x 1.5 THD	N/A	N/A	61 kg
B1	356	101.676 101.625	146.05	N/A	SAE-B spline 13 tooth 16/32 pitch	1/2-13 UNC-2B THD	M12 x 1.75 THD	N/A	N/A	64 kg
B2	356	101.676 101.625	146.05	N/A	SAE-BB spline 15 tooth 16/32 pitch	1/2-13 UNC-2B THD	M12 x 1.75 THD	N/A	N/A	64 kg
C1, C3	358	127.075 127.025	180.98	114.5	SAE-C spline 14 tooth 12/24 pitch	5/8-11 UNC-2B THD	M16 x 2 THD	1/2-13 UNC-2B THD	M12 x 1.75 THD	65 kg

P2145 Mounting flange

SAE D 4-bolt mounting flange

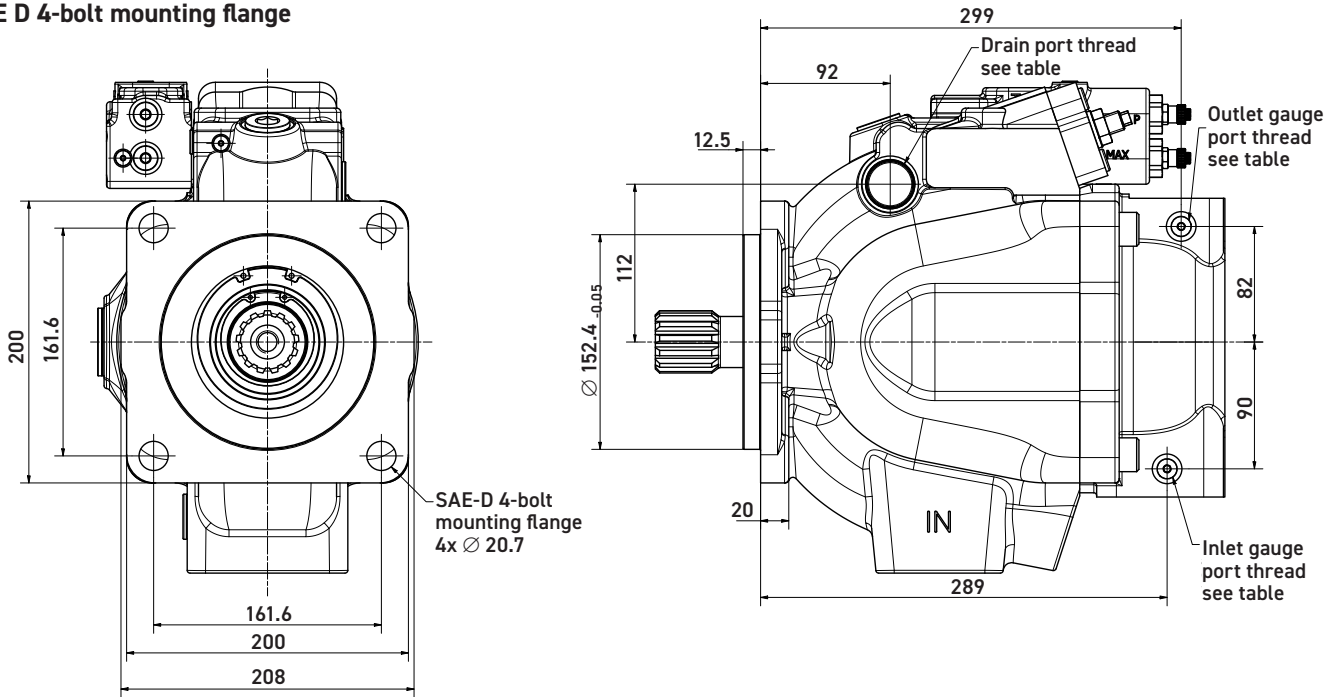

SAE C 2-bolt mounting flange

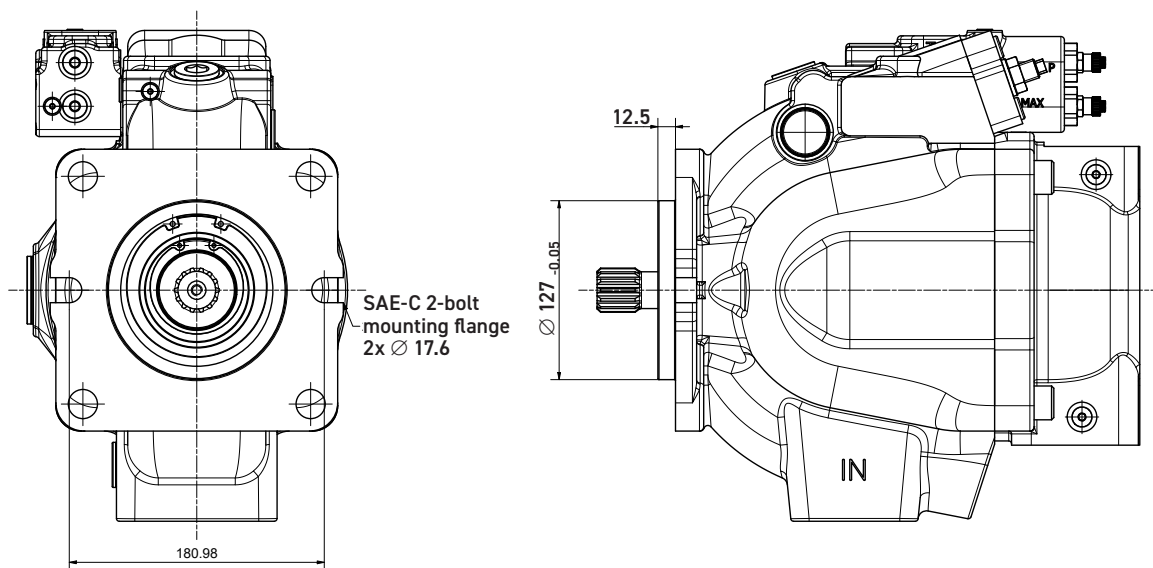

CW pump shown.
 CCW pump will have inlet and outlet gauge ports opposite side.



Port ordering code	Drain port	Inlet gauge port / Outlet gauge port
"A" side - UNC	SAE-12 straight thread / O-ring port: 1-1/16-12 UN thread	SAE-4 straight thread / O-ring port: 7/16-20 UN thread
"B" side - metric	ISO 6149 straight thread / O-ring port: M27 x 2 thread	ISO 6149 straight thread / O-ring port: M12 x 1.5 thread

P2145 Side port

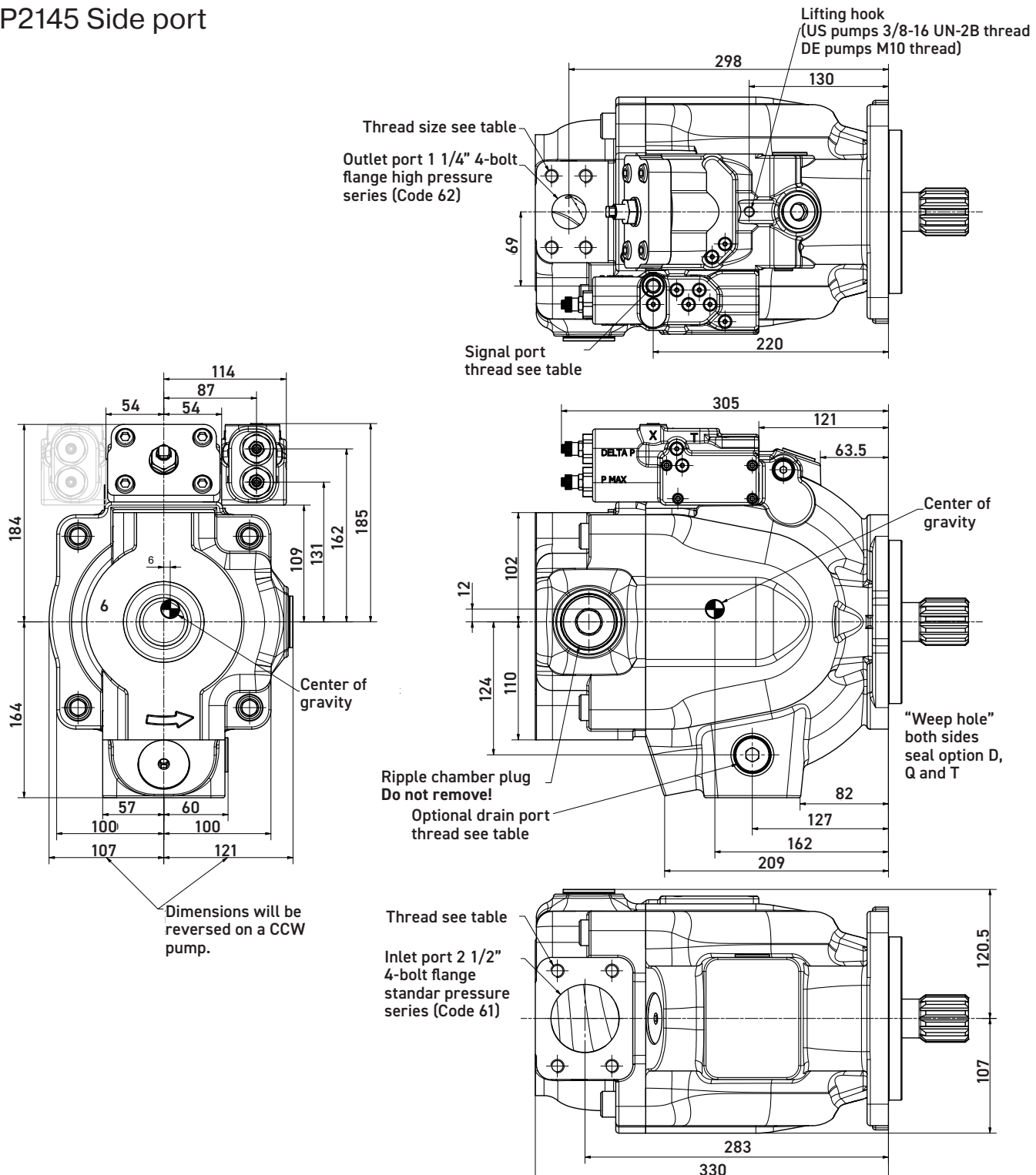

Pump shown is a CW rotation P2145 series pump with load sense and max. pressure compensator.

As an option the compensator unit can be positioned at opposite side of the pump. Please consult manufacturer for details.

CCW pump will have inlet and outlet gauge ports opposite side.

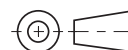

Port option	Drain port	Inlet port	Outlet port	Inlet gauge port / Outlet gauge port / Signal port
"A" side - UNC	SAE-12 straight thread / O-ring port: 1-1/16-12 thread	1/2-13 UN	1/2-13 UN	SAE-4 straight thread / O-ring port: 7/16-20 UN thread
"B" side - metric	ISO 6149 straight thread / O-ring port: M27 x 2 thread	M12 x 1.75	M12 x 1.75	ISO 6149 straight thread / O-ring port: M12 x 1.5 thread

P2145 Thru-drive option

A1 configuration

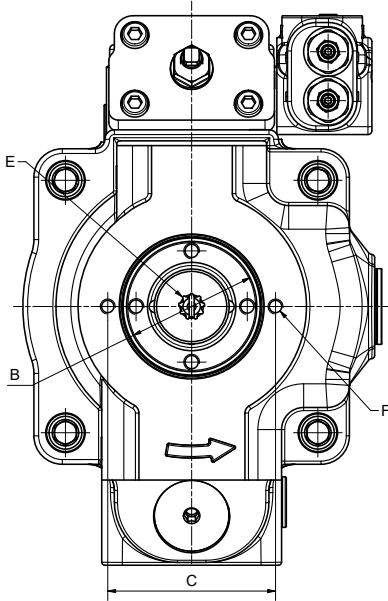

B1 and B2 configurations

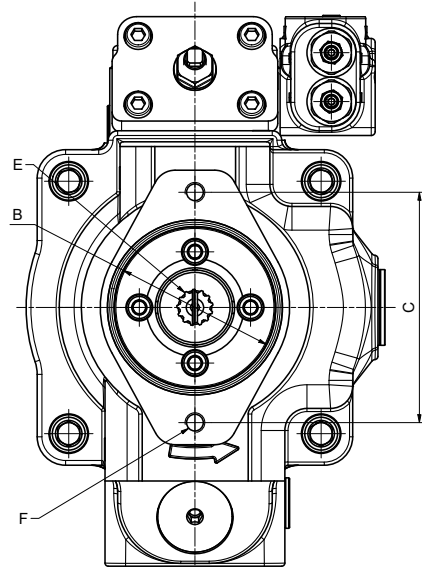

C1, C2, C3 and C4 configurations

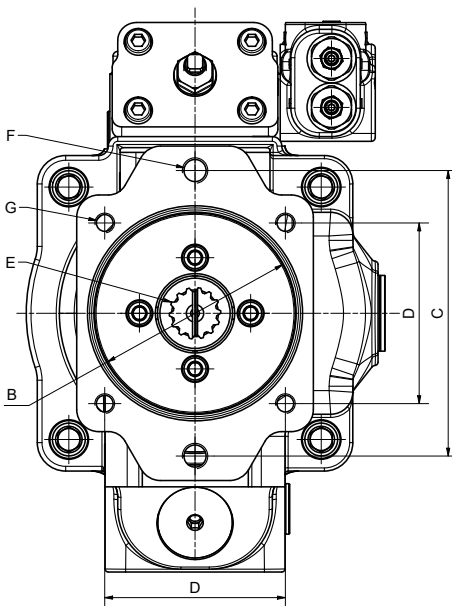

D3 configuration

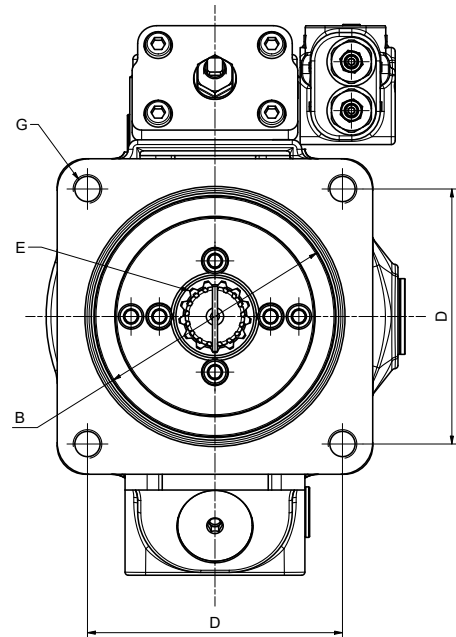

P2145 Thru-drive option

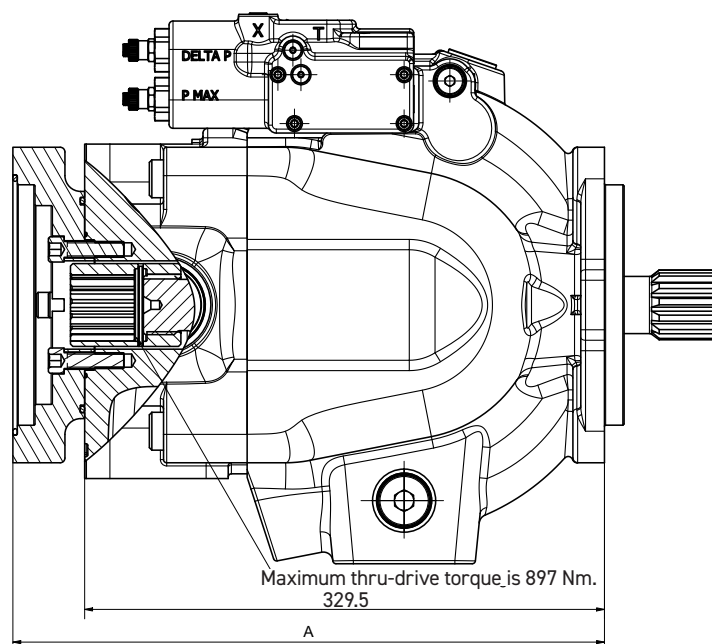

Thru-shaft option	A	B Ø	C	D	E	F UNC	F metric	G UNC	G metric	Weight
A1	329.5	82.626 82.575	106.38	N/A	SAE-A spline 9 tooth 16/32 pitch	3/8-16 UNC-2B THD	M10 x 1.5 THD	N/A	N/A	79.8 kg
B1	362.5	101.676 101.625	146.05	N/A	SAE-B spline 13 tooth 16/32 pitch	1/2-13 UNC-2B THD	M12 x 1.75 THD	N/A	N/A	82.6 kg
B2	362.5	101.676 101.625	146.05	N/A	SAE-BB spline 15 tooth 16/32 pitch	1/2-13 UNC-2B THD	M12 x 1.75 THD	N/A	N/A	82.6 kg
C1 & C2	364.5	127.075 127.025	180.98	NA	SAE-C spline 14 tooth 2/24 pitch	5/8-11 UNC-2B THD	M16 x 2 THD	1/2-13 UNC-2B THD	M12 x 1.75 THD	83.9 kg
C3	364.5	127.075 127.025	180.98	114.5	SAE-C spline 14 tooth 2/24 pitch	5/8-11 UNC-2B THD	M16 x 2 THD	1/2-13 UNC-2B THD	M12 x 1.75 THD	83.9 kg
C4	364.5	127.075 127.025	180.98	114.5	SAE-CC spline 17 tooth 2/24 pitch	5/8-11 UNC-2B THD	M16 x 2 THD	1/2-13 UNC-2B THD	M12 x 1.75 THD	83.9 kg
D3	375	152.475 152.425	NA	161.65	SAE-D spline 13 tooth 8/16 pitch	NA	NA	3/4-10 UNC-2B THD	M16 x 2 THD	88 kg

P2 Shaft options

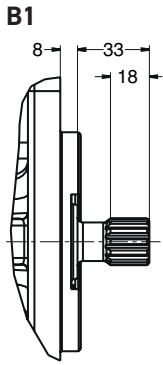

B1
SAE "B" spline
13 tooth
16/32 pitch
30° involute spline
Max. input torque
209 Nm

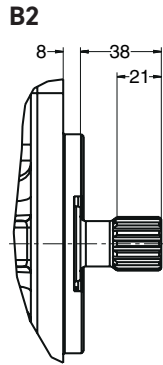

B2
SAE "B-B" spline
15 tooth
16/32 pitch
30° involute spline
Max. input torque
337 Nm

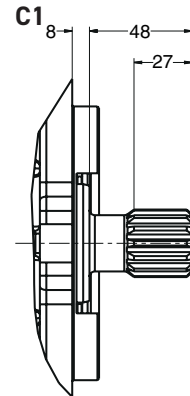

C1
SAE "C" spline
14 tooth
12/24 pitch
30° involute spline
Max. input torque
641 Nm

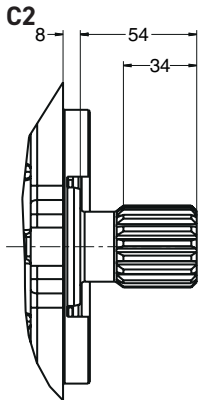

C2
SAE "C-C" spline
17 tooth
12/24 pitch
30° involute spline
Max. input torque
1217 Nm

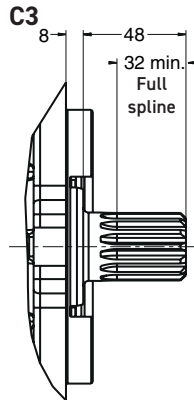

C3
SAE "C" spline
no undercut
14 tooth
12/24 pitch
30° involute spline
Max. input torque
769 Nm

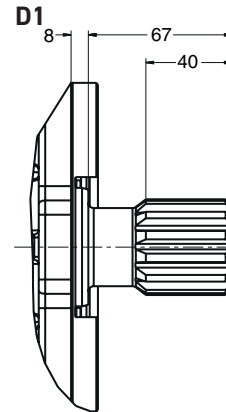

D1
SAE D
13 tooth
8/16 pitch
30° involute spline
Max. input torque
1701 Nm

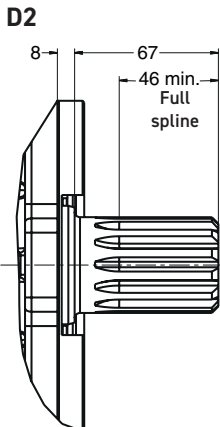

D2
SAE "D" spline
no undercut
13 tooth
8/16 pitch
30° involute spline
Max. input torque
2041 Nm

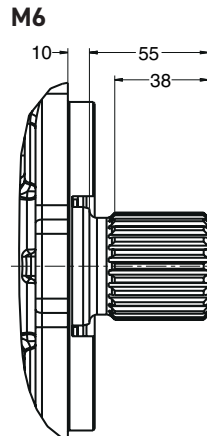

M6
DIN 5480 spline
W50x2x30x24x9g
Max. input torque
3050 Nm

Torque control dimensions

Torque control options "TA", "TB", "TC" and "TD"

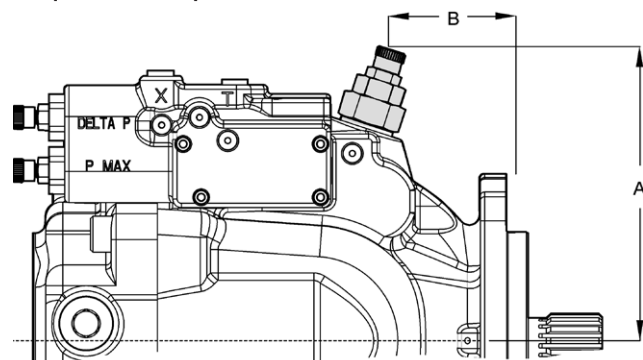

	P2060	P2075	P2105	P2145
A	163	171	190	202
B	34	69	69	69
C	161	154	175	186

PERFORMANCE CURVES P3

P3 Noise characteristics at max./min. displacement

P3105 Noise characteristics

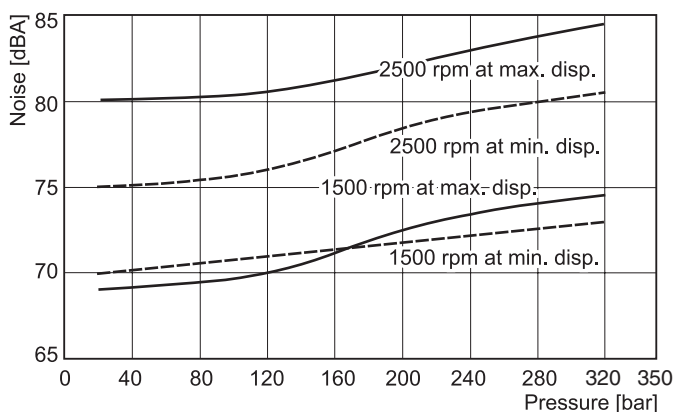

P3 Series - typical drive power at full displacement

P3105 Input power - full stroke

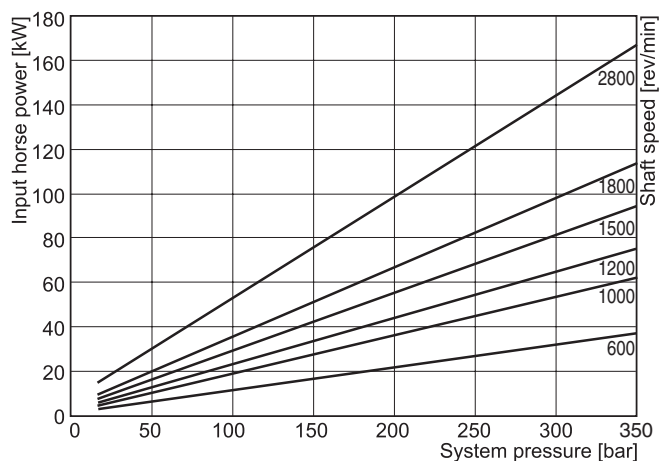

P3145 Noise characteristics

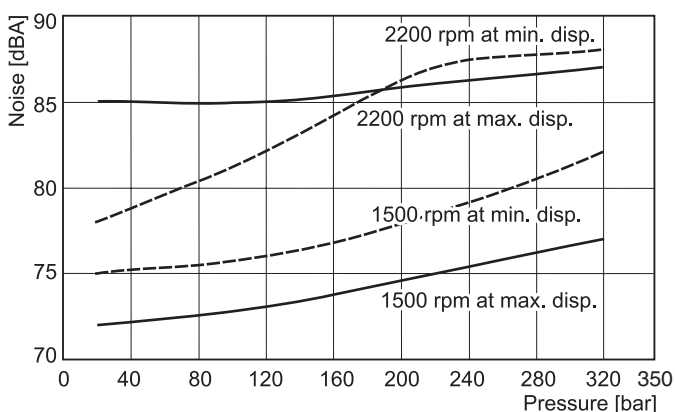

P3145 Input power - full stroke

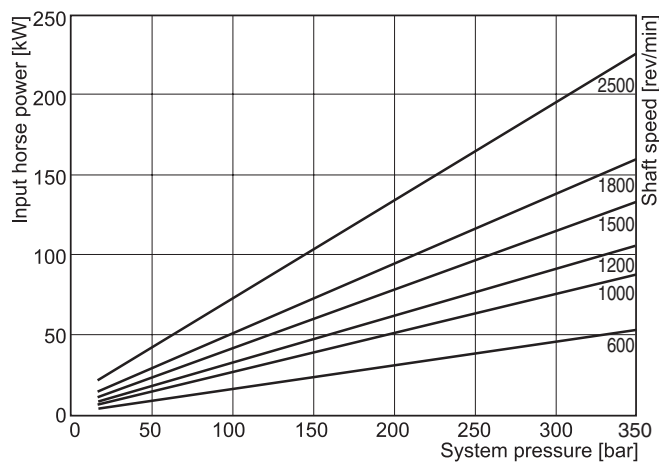

Fluid: Mineral oil ISO VG 32 at 40°C ; Inlet pressure: 1.0 bar (absolute) measured at inlet port.

P3 Series - typical compensated input power

P3 Series - typical efficiency at full displ. at 1800 rpm

P3105 Input power - zero stroke

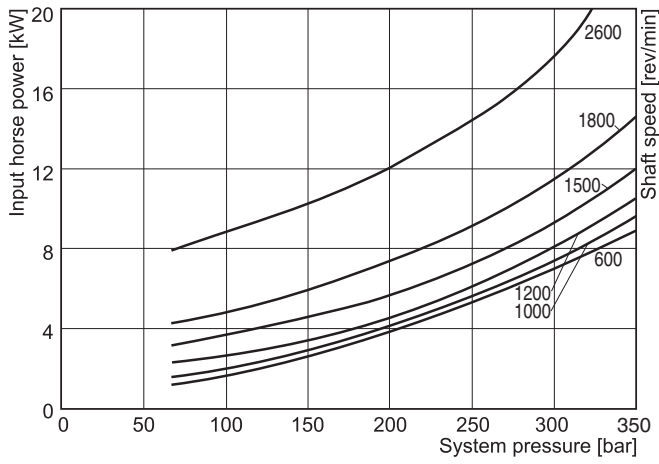

P3105 Efficiency at 1800 rpm

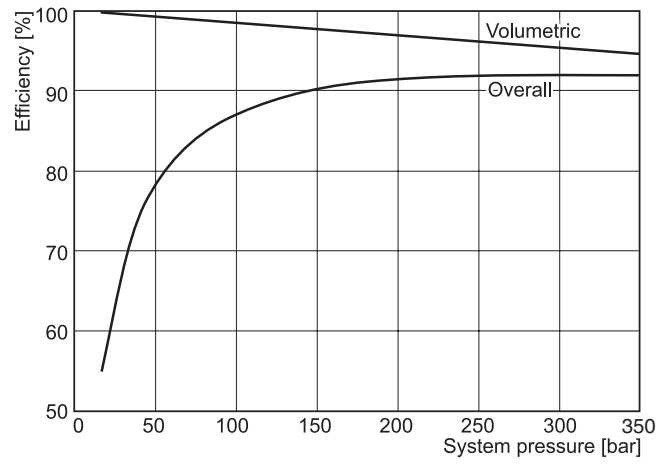

P3145 Input power - zero stroke

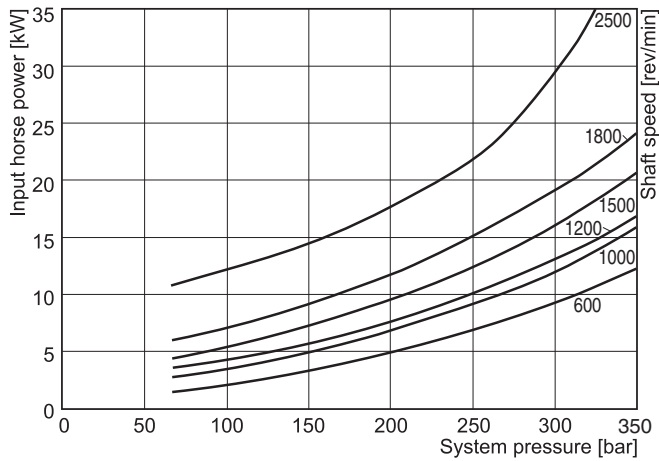

P3145 Efficiency at 1800 rpm

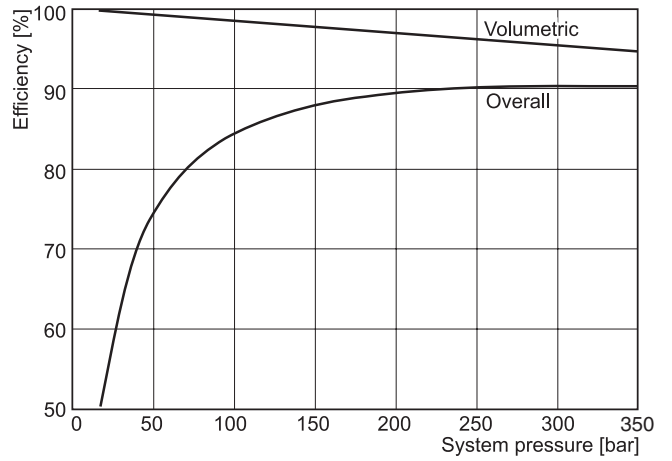

Fluid: Mineral oil ISO VG 32 at 40°C ; Inlet pressure: 1.0 bar (absolute) measured at inlet port.

P3 Series - typical flow vs. pressure

P3105 Outlet flow - full stroke

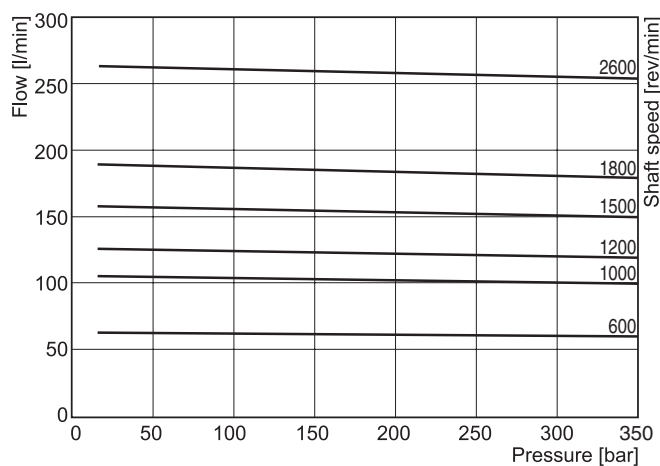

P3 Series - typical compensated drain flow

P3105 Drain flow at zero stroke

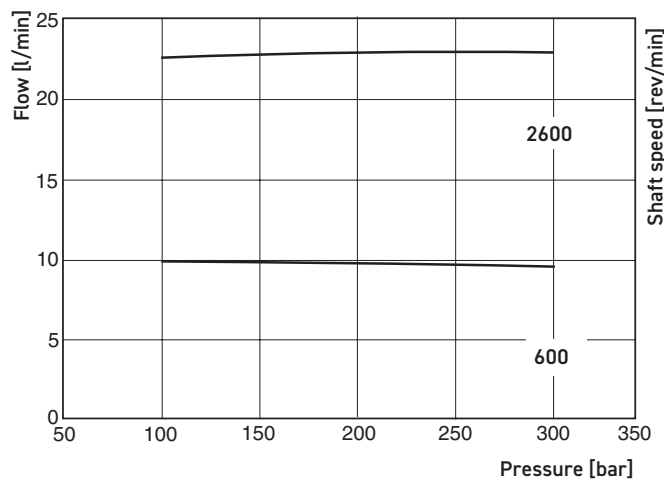

P3145 Outlet flow - full stroke

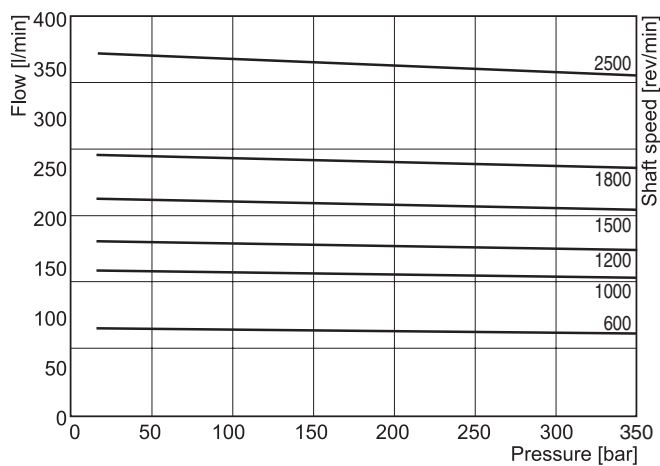

P3145 Drain flow at zero stroke

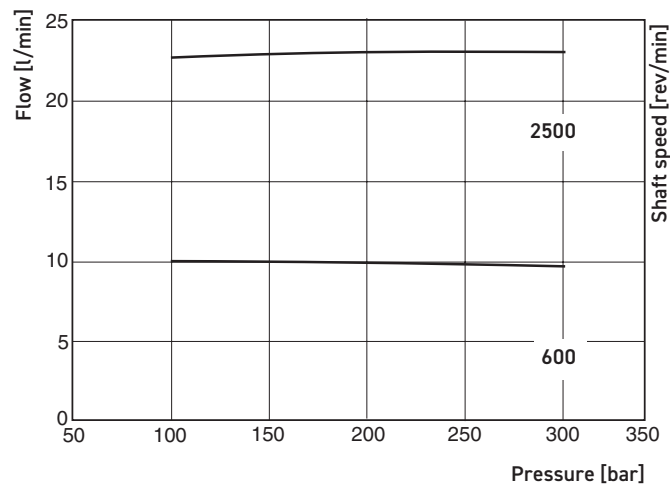

Fluid: Mineral oil ISO VG 32 at 40°C ; Inlet pressure: 1.0 bar (absolute) measured at inlet port.

P3 Series - typical inlet characteristics vs. speed at various percentage displacements

P3105 Inlet characteristics

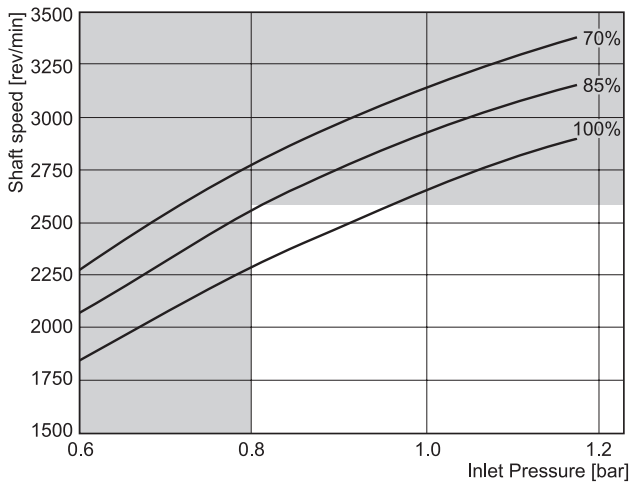

P3145 Inlet characteristics

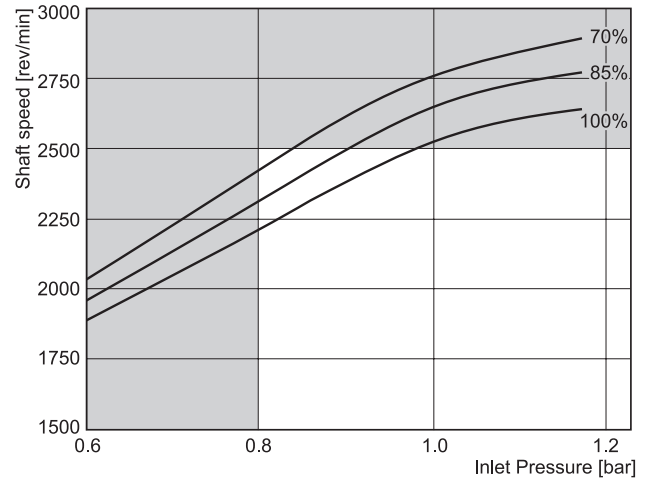

Fluid: Mineral oil ISO VG 32 at 40°C ; Inlet pressure: 1.0 bar (absolute) measured at inlet port.



For operation at these speeds, please consult manufacturer for approval.

DIMENSIONS P3

P3105 Mounting flange

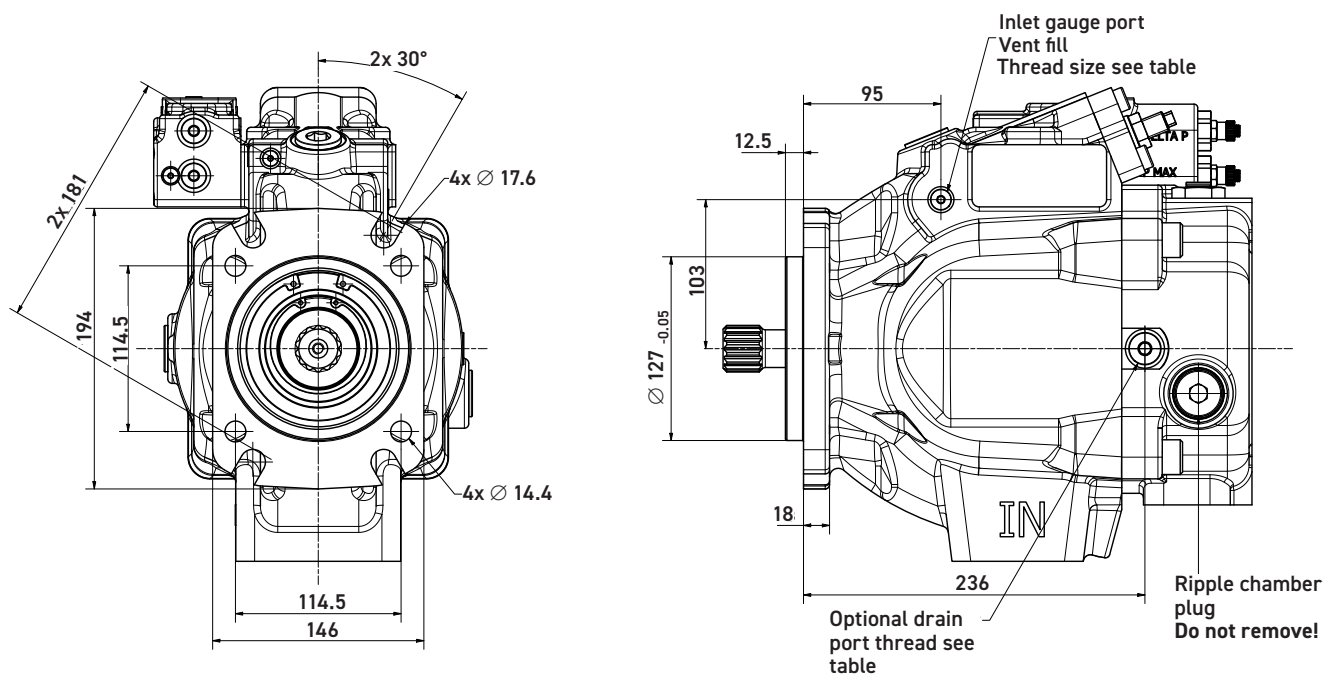

CW pump shown

CCW pump will have outlet gauge port at opposite side



Port ordering code	Drain port	Airbleed port / vent port
"A" side - UNC	SAE-8 straight thread / O-ring port: 3/4 - 16 UN thread	SAE-4 straight thread / O-ring port: 7/16-20 UN thread
"B" side - metric	ISO 6149 straight thread / O-ring port: M18 x 1.5 thread	ISO 6149 straight thread / O-ring port: M12 x 1.5 thread

P3105 Side port

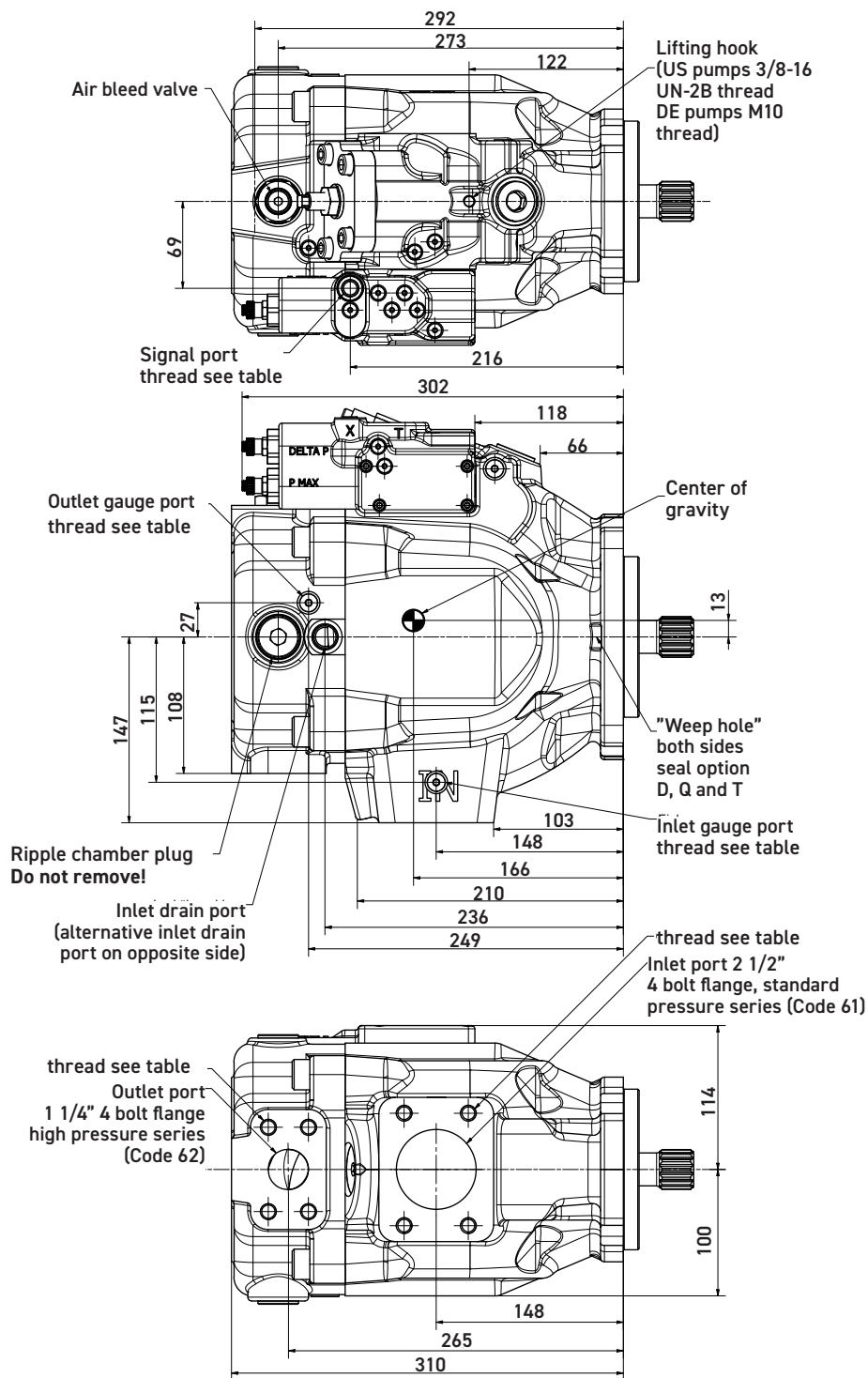
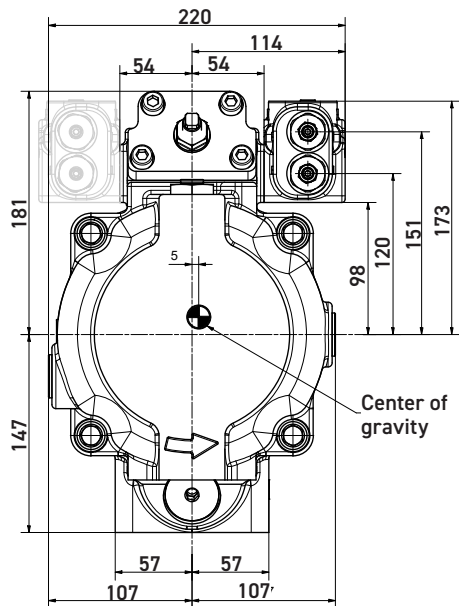

Pump shown is a CW rotation P3105 series pump with load sense and max. pressure compensator.

As an option the compensator unit can be positioned at opposite side of the pump. Please consult manufacturer for details.

CCW pump will have outlet gauge port at opposite side.

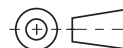

Port ordering code	Drain port	Inlet port	Outlet port	Inlet gauge port / Outlet gauge port / Airbleed port / Signal port
"A" side - UNC	SAE 8 straight thread / O-ring port: 3/4 - 16 UN thread	1/2-13 UNC	1/2-13 UNC	SAE-4 straight thread / O-ring port: 7/16-20 UN thread
"B" side - metric	ISO 6149 straight thread / O-ring port: M18 x 1.5 thread	M12 x 1.75	M12 x 1.75	ISO 6149 straight thread / O-ring port: M12 x 1.5 thread

P3105 Thru-drive option

A1 Configuration

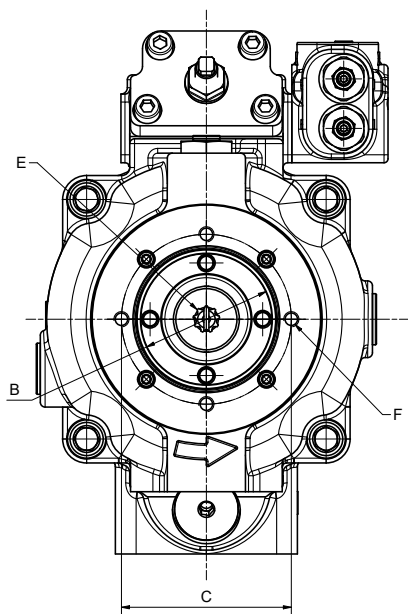

B1 and B2 Configuration

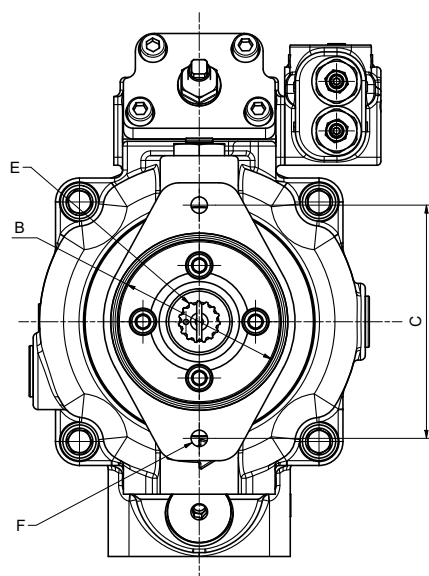

C1 and C3 Configuration

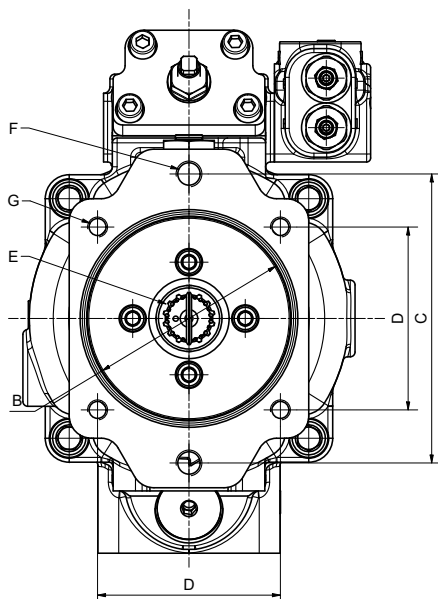

P3105 Partial cut-away of thru-drive area

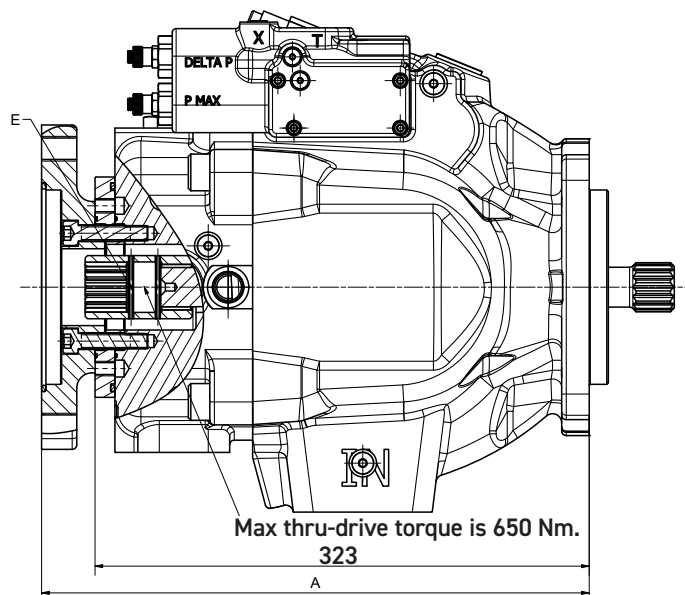

Thru-shaft option	A	B Ø	C	D	E	F UNC	F metric	G UNC	G metric	Weight
A1	323	82.626 82.575	106.3	N/A	SAE-A spline 9 tooth 16/32 pitch	3/ 16 UNC-2B THD	M10 x 1.5 THD	N/A	N/A	63 kg
B1	356	101.676 101.625	146.1	N/A	SAE-B spline 13 tooth 16/32 pitch	1/2-13 UNC- 2B THD	M12 x 1.75 THD	N/A	N/A	64 kg
B2	356	101.676 101.625	146.1	N/A	SAE-BB spline 15 tooth 16/32 pitch	1/2-13 UNC- 2B THD	M12 x 1.75 THD	N/A	N/A	64 kg
C1 C3	358	127.075 127.025	181	114.5	SAE-C spline 14 tooth 12/24 pitch	1/2-13 UNC- 2B THD	M12 x 1.75 THD	5/8-11 UNC-2B THD	M16 x 2 THD	66 kg

P3145 Mounting flange

SAE C 2-bolt mounting flange

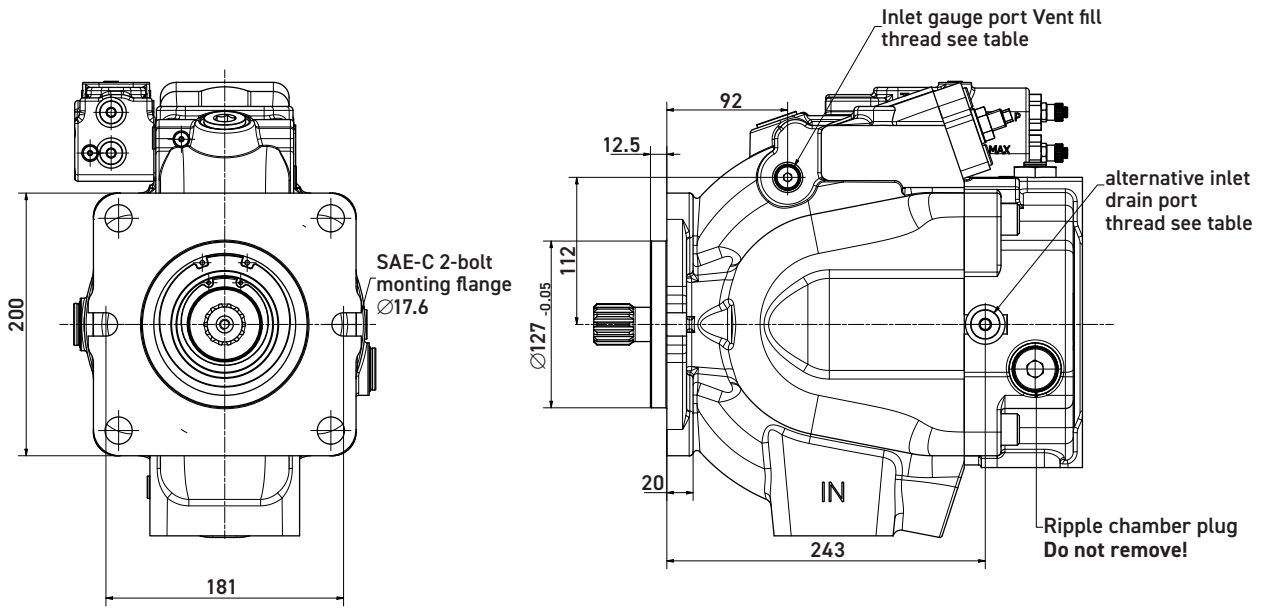

SAE D 4-bolt mounting flange

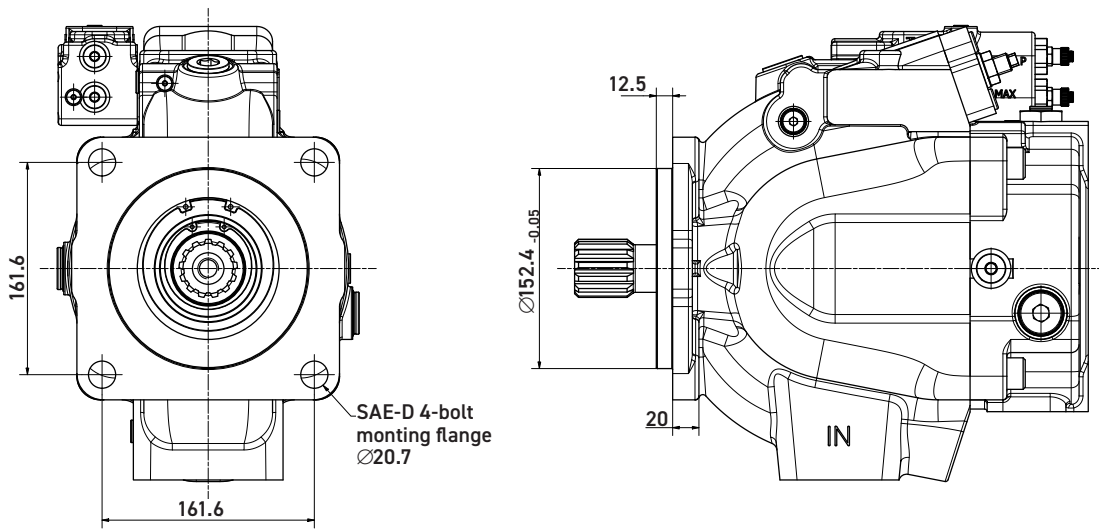

CW pump shown
 CCW pump will have outlet gauge port at opposite side



Port ordering code	Drain port	Airbleed port / vent port
"A" side - UNC	SAE 8 straight thread / O-ring port: 3/4 - 16 UN thread	SAE-4 straight thread / O-ring port: 7/16-20 UN thread
"B" side - metric	ISO 6149 straight thread / O-ring port: M18 x 1.5 thread	ISO 6149 straight thread / O-ring port: M12 x 1.5 thread

P3145 Side port

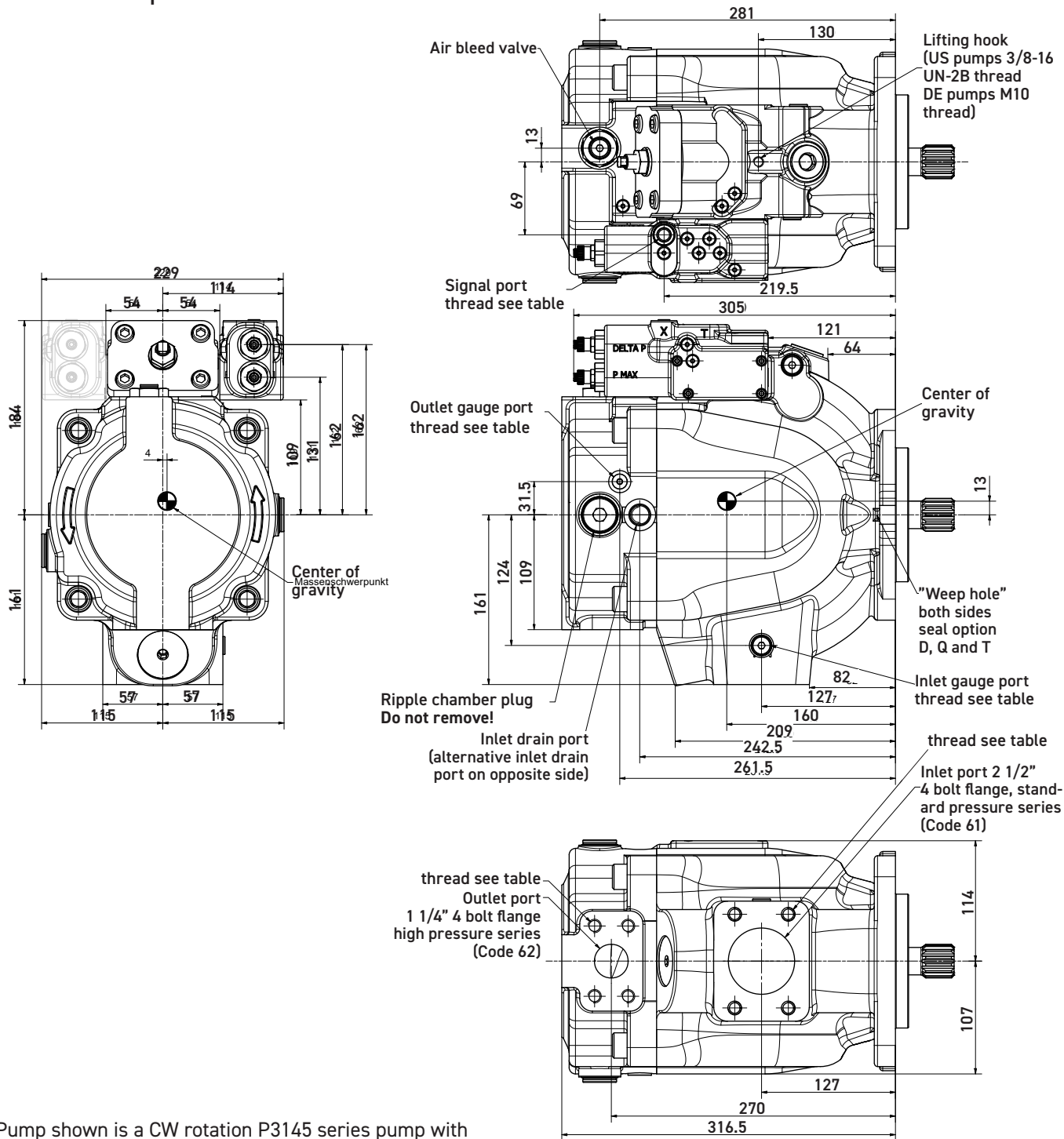

Pump shown is a CW rotation P3145 series pump with load sense and max. pressure compensator.

As an option the compensator unit can be positioned at opposite side of the pump. Please consult manufacturer for details.

CCW pump will have inlet and outlet gauge ports at opposite side.

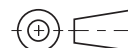

Port ordering code	Drain port	Inlet port	Outlet port	Inlet gauge port / Outlet gauge port / Airbleed port / Signal port
"A" side - UNC	SAE 8 straight thread / O-ring port: 3/4 - 16 UN thread	1/2-13 UNC	1/2-13 UNC	SAE-4 straight thread / O-ring port: 7/16-20 UN thread
"B" side - metric	ISO 6149 straight thread / O-ring port: M18 x 1.5 thread	M12 x 1.75	M12 x 1.75	ISO 6149 straight thread / O-ring port: M12 x 1.5 thread

P3145 Thru-drive option

A1 Configuration

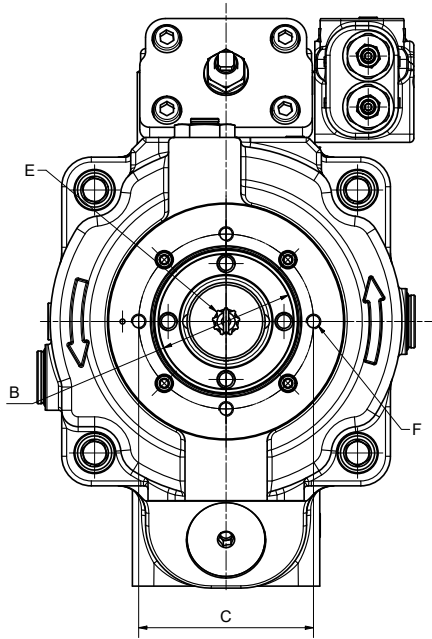

B1 and B2 Configuration

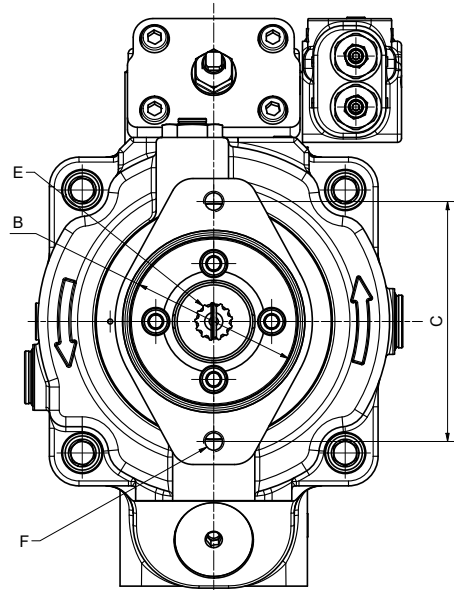

C1, C2, C3 and C4 Configuration

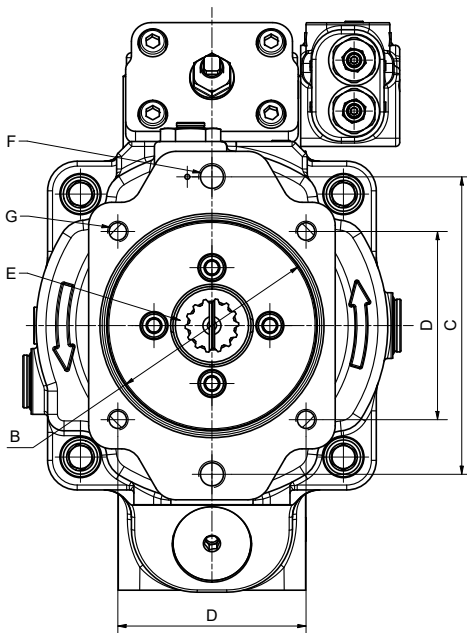

D3 Configuration

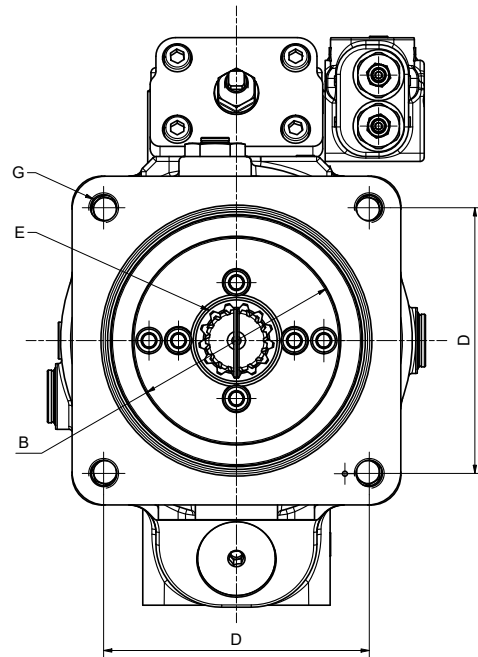

P3145 Thru-drive option

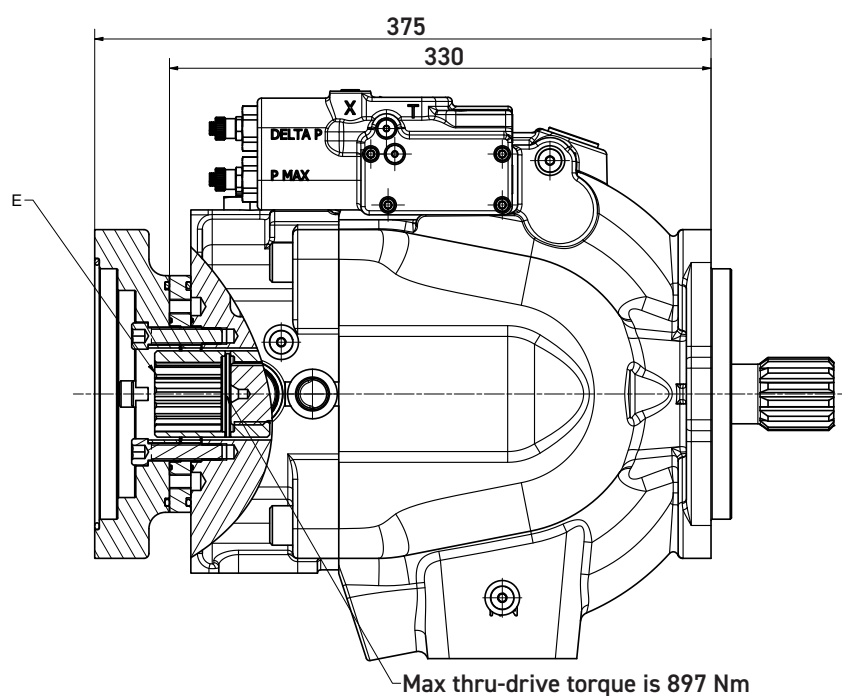

Thru-shaft option	A	B Ø	C	D	E	F UNC	F metric	G UNC	G metric	Weight
A1	329.5	82.626 82.575	106.38	N/A	SAE-A spline 9 tooth 16/32 pitch	3/8-16 UNC-2B THD	M10 x 1.5 THD	N/A	N/A	75.9 kg
B1	362.5	101.676 101.625	146.05	N/A	SAE-B spline 13 tooth 16/32 pitch	1/2-13 UNC-2B THD	M12 x 1.75 THD	N/A	N/A	78.5 kg
B2	362.5	101.676 101.625	146.05	N/A	SAE-BB spline 15 tooth 16/32 pitch	1/2-13 UNC-2B THD	M12 x 1.75 THD	N/A	N/A	78.5 kg
C1	364.5	127.075 127.025	180.98	NA	SAE-C spline 14 tooth 12/24 pitch	5/8-11 UNC-2B THD	M16 x 2 THD	1/2-13 UNC-2B THD	M12 x 1.75 THD	80 kg
C2	364.5	127.075 127.025	180.98	NA	SAE-C spline 17 tooth 12/24 pitch	5/8-11 UNC-2B THD	M16 x 2 THD	1/2-13 UNC-2B THD	M12 x 1.75 THD	80 kg
C3	364.5	127.075 127.025	180.98	114.5	SAE-C spline 14 tooth 12/24 pitch	5/8-11 UNC-2B THD	M16 x 2 THD	1/2-13 UNC-2B THD	M12 x 1.75 THD	80 kg
C4	364.5	127.075 127.025	180.98	114.5	SAE-CC spline 17 tooth 12/24 pitch	5/8-11 UNC-2B THD	M16 x 2 THD	1/2-13 UNC-2B THD	M12 x 1.75 THD	80 kg
D3	375	152.475 152.425	NA	161.65	SAE-D spline 13 tooth 8/16 pitch	NA	NA	3/4-10 UNC-2B THD	M16 x 2 THD	83.7 kg

P3 Shaft options

C1

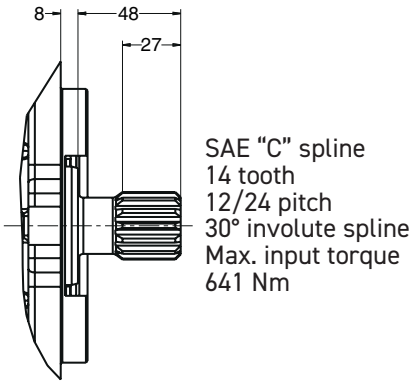

SAE "C" spline
14 tooth
12/24 pitch
30° involute spline
Max. input torque
641 Nm

C2

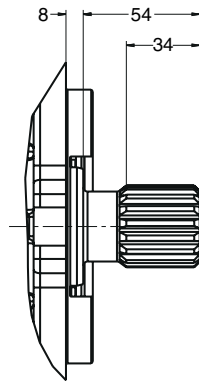

SAE "C-C" spline
17 tooth
12/24 pitch
30° involute spline
Max. input torque
1217 Nm

C3

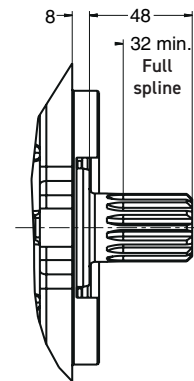

SAE "C" spline
no undercut
14 tooth
12/24 pitch
30° involute spline
Max. input torque
769 Nm

D1

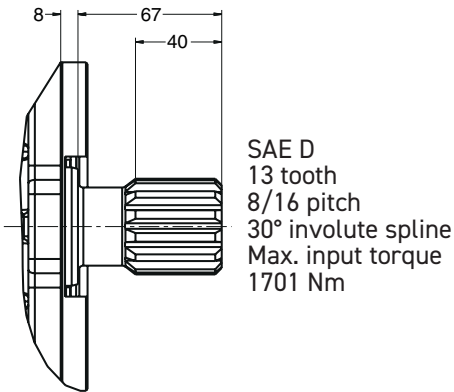

SAE D
13 tooth
8/16 pitch
30° involute spline
Max. input torque
1701 Nm

D2

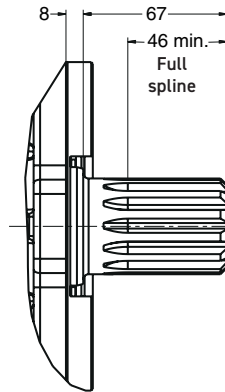

SAE "D" spline
no undercut
13 tooth
8/16 pitch
30° involute spline
Max. input torque
2041 Nm

M6

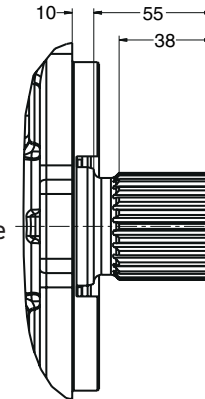

DIN 5480 spline
W50x2x30x24x9g
Max. input torque
3050 Nm

Torque control dimensions

Torque control options "TA", "TB", "TC" and "TD"

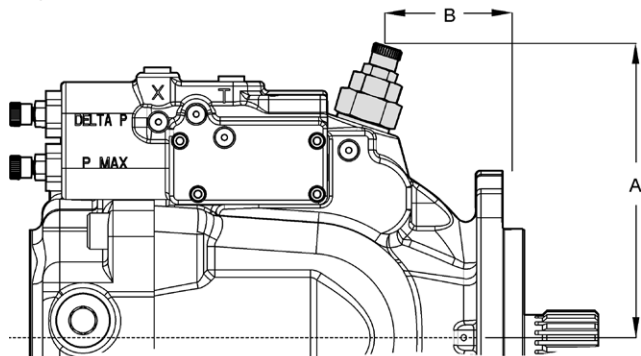

	P3105	P3145
A	190	202
B	69	69

GENERAL INSTALLATION INFORMATION

Multiple pump combinations - Maximum moment

To avoid excessive front flange loads combinations of multiple pumps might require additional pump support.

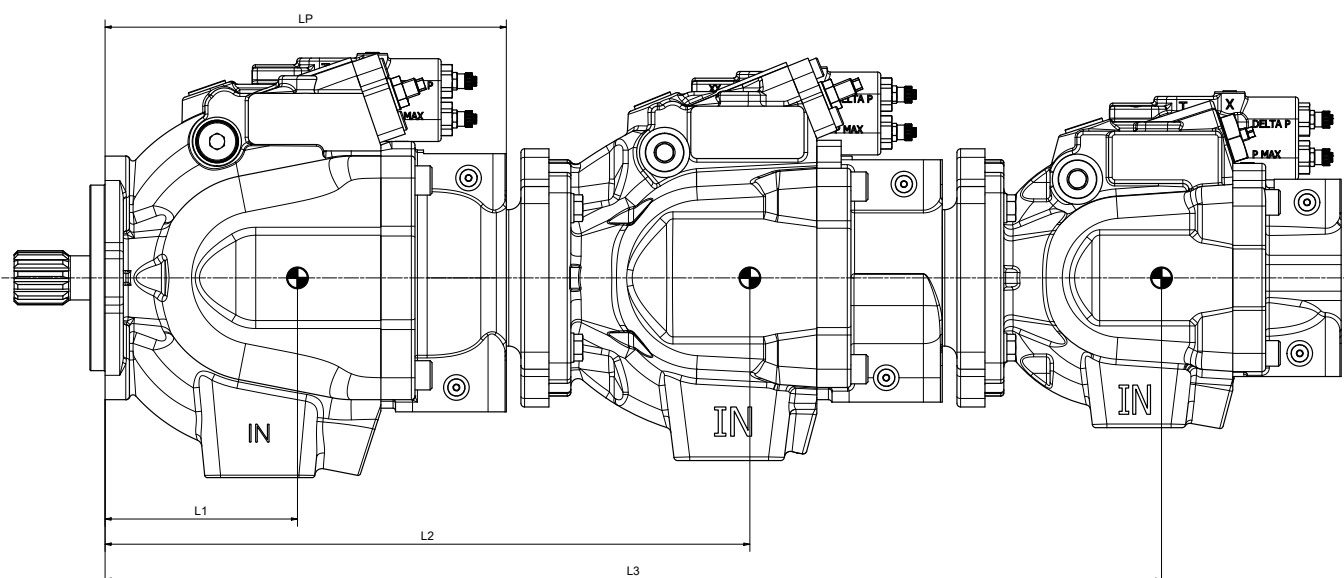

Chart 1. Maximum moment and pump dimensions

		P2060	P2075	P2105	P2145
Maximum Moment	[Nm]	197	266	425	556
Weight Force	[N]	358	431	618	805
Distance L1	[mm to C/G]	126	145	165	158
Distance Lp	[mm]	264	292	323	329

Chart 2. Through drive adapter plate thickness

LF		P2060	P2075	P2105	P2145
SAE - A Flange	[mm]	0	0	0	0
SAE - B Flange	[mm]	33	33	33	33
SAE - C Flange	[mm]	35	35	35	35
SAE - D Flange	[mm]	–	–	–	45.5

Resulting moment can be calculated by using the following formula:

$$\text{Moment } M = (L1*W1+L2*W2+L3*W3+...)$$

If resulting moment exceeds the maximum value given in chart 1 additional support is mandatory.

Multiple pump combinations - Maximum thru drive torque

		P2060	P2075	P2105/ P3105	P2145/ P3145
Torque	[Nm]	339	424	650	897

Fluid recommendations

The fluid recommended for use in these pumps has a petroleum base and contains agents which provide oxidation inhibition and anti-rust, anti-foam and de-aerating properties as described in PARKER standard HF-1. Where anti-wear additive fluids are specified, see PARKER standard HF-0.

Viscosity

Min. viscosity for short periods:	10 mm ² /s (cSt)
Normal operating viscosity:	15...40 mm ² /s (cSt)
Max. viscosity for short periods:	1000 mm ² /s (cSt)

Filtration

For maximum pump and system component functionality and life, the system should be protected from contamination by effective filtration.

Fluid cleanliness should be in accordance with ISO classification ISO 4406. The quality of filter elements should be in accordance with ISO standards.

Recommendation for filtration:

Class 21/18/14, according to ISO 4406

Seals

Check hydraulic fluid specification for chemical resistance of seal material.

Check temperature range of seal material and compare with max. system and ambient temperature.

N/D - NBR seals, FPM shaft seal(s)	-25 ... +90 °C
B/Q - NBR seals, NBR shaft seal(s)	-40 ... +90 °C
V/T - FPM seals, FPM shaft seal(s)	-25 ... +115 °C

Note: Above limitations refer to average case drain temperature, which can be up to 20 °C higher than in the reservoir.

Axial / Radial Loads

Units subjected to radial loads require the installation of an outboard bearing. Axial Loads are not permitted.

**WARNING – USER RESPONSIBILITY**

FAILURE OR IMPROPER SELECTION OR IMPROPER USE OF THE PRODUCTS DESCRIBED HEREIN OR RELATED ITEMS CAN CAUSE DEATH, PERSONAL INJURY AND PROPERTY DAMAGE.

- This document and other information from Parker-Hannifin Corporation, its subsidiaries and authorized distributors provide product or system options for further investigation by users having technical expertise.
- The user, through its own analysis and testing, is solely responsible for making the final selection of the system and components and assuring that all performance, endurance, maintenance, safety and warning requirements of the application are met. The user must analyze all aspects of the application, follow applicable industry standards, and follow the information concerning the product in the current product catalog and in any other materials provided from Parker or its subsidiaries or authorized distributors.
- To the extent that Parker or its subsidiaries or authorized distributors provide component or system options based upon data or specifications provided by the user, the user is responsible for determining that such data and specifications are suitable and sufficient for all applications and reasonably foreseeable uses of the components or systems.

Offer of Sale

Please contact your Parker representation for a detailed "Offer of Sale".

