



Air Preparation Units

Parker-Watts Stainless Steel
Filters, Regulators, Lubricators

Catalog 0300-2

aerospace
climate control
electromechanical
filtration
fluid & gas handling
hydraulics
pneumatics
process control
sealing & shielding



ENGINEERING YOUR SUCCESS.

 **WARNING**

FAILURE OR IMPROPER SELECTION OR IMPROPER USE OF THE PRODUCTS AND/OR SYSTEMS DESCRIBED HEREIN OR RELATED ITEMS CAN CAUSE DEATH, PERSONAL INJURY AND PROPERTY DAMAGE.

This document and other information from Parker Hannifin Corporation, its subsidiaries and authorized distributors provide product and/or system options for further investigation by users having technical expertise. It is important that you analyze all aspects of your application including consequences of any failure, and review the information concerning the product or system in the current product catalog. Due to the variety of operating conditions and applications for these products or systems, the user, through its own analysis and testing, is solely responsible for making the final selection of the products and systems and assuring that all performance, safety and warning requirements of the application are met.

The products described herein, including without limitation, product features, specifications, designs, availability and pricing, are subject to change by Parker Hannifin Corporation and its subsidiaries at any time without notice.

Offer of Sale

The items described in this document are hereby offered for sale by Parker Hannifin Corporation, its subsidiaries or its authorized distributors. This offer and its acceptance are governed by the provisions stated on the separate page of this document entitled "Offer of Sale".

Product Selection Chart 1

Air Line Filters

Miniature F5042-3

Standard F104-5

Air Line Coalescing Filters

Miniature F5016-7

Standard F118-9

Air Line Regulators

Miniature R354, R36410-11

Standard R10, R1112-13

Air Line Filter / Regulator

Miniature B548, B55814-15

Standard B11, B12.....16-17

Air Line Lubricators

Standard L1018-19

Safety Guide.....20-21

Offer of Sale22

Product Selection Chart

Basic Unit	Series	Port Size		Bowls	Capacity	Elements (Micron)			Page
		1/4	1/2			5	20	40	
FILTERS	F504	X	—	316 Stainless Steel	1 oz.	Opt.	Std.	—	4-5
	F10	—	X	316 Stainless Steel	4 oz.	Opt.	—	Std.	6-7
COALESCING FILTERS	F501	X	—	316 Stainless Steel	1 oz.	.3 Micron			8-9
	F11	—	X	316 Stainless Steel	4 oz.	.3 Micron			10-11

Basic Unit	Series	Port Size		Spring Range				Page
		1/4	1/2	25	60	125	250	
REGULATORS	R354	X	—	Std.	Std.	Std.	—	12-13
	R364	X	—	Std.	Std.	Std.	—	
	R10	—	X	—	Std.	Std.	Opt.	14-15
	R11	—	X	—	Std.	Std.	Opt.	

Basic Unit	Series	Port Size		Bowls	Capacity	Elements (Micron)			Spring Range				Page
		1/4	1/2			5	20	40	25	60	125	250	
FILTER / REGULATORS	B548	X	—	316 Stainless Steel	1 oz.	Opt.	Std.	—	Opt.	Opt.	Std.	—	16-17
	B558	X	—	316 Stainless Steel	1 oz.	Opt.	Std.	—	Opt.	Opt.	Std.	—	
	B11	—	X	316 Stainless Steel	4 oz.	Opt.	—	Std.	—	Opt.	Std.	Opt.	18-19
	B12	—	X	316 Stainless Steel	4 oz.	Opt.	—	Std.	—	Opt.	Std.	Opt.	
LUBRICATORS	L10	—	X	316 Stainless Steel	4 oz.							20-21	



F504 Filter – Miniature

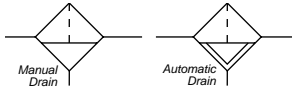

Features

- Stainless steel construction handles most corrosive environments.
- Fluorocarbon seals standard.
- Meets NACE specifications MR-01-75/ISO 15156.
- 1/8" female threaded drain.
- High Flow: 1/4" - 23 SCFM[§]

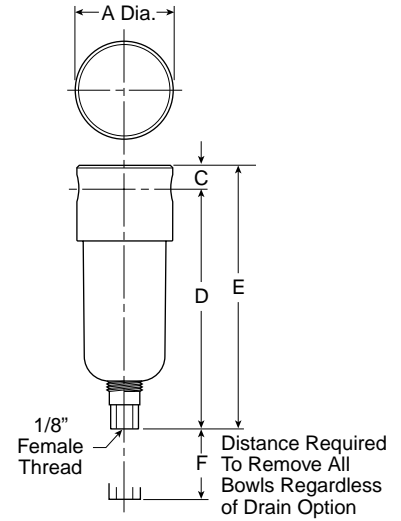

Port Size	NPT	BSPB
	Manual Twist Drain	Manual Twist Drain
1/4"	F504-02DHSS	F504G02DHSS

F504 Filter Dimensions		
A	C	D
1.56 (40)	0.31 (8)	3.69 (94)
E	F	
4.00 (102)	1.58 (40)	

Standard part numbers shown bold.
 For other models refer to ordering information below.
 SCFM = Standard cubic feet per minute at 90 PSIG inlet and 5 PSIG pressure drop.

inches
(mm)

Ordering Information

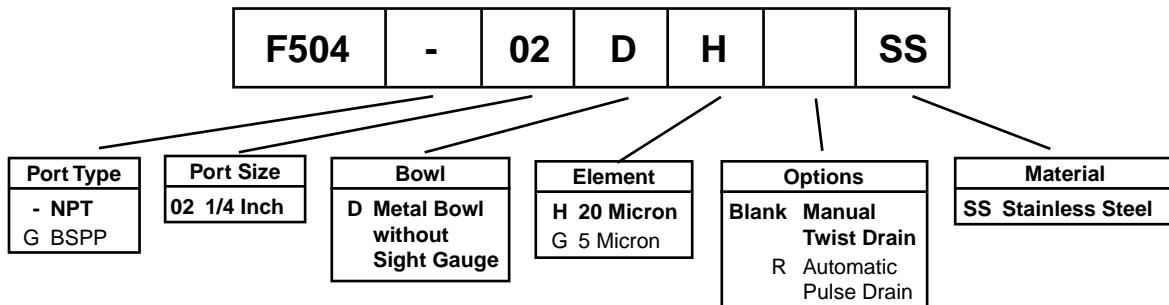

BOLD ITEMS ARE MOST POPULAR.

Operation

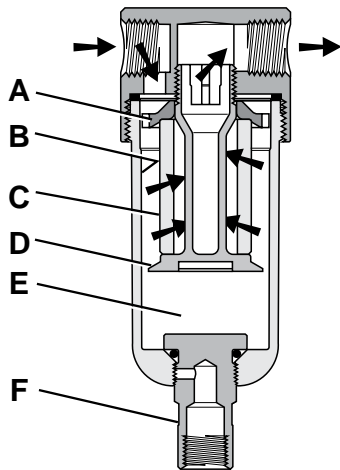

First Stage Filtration:

Air enters at inlet port and flows through deflector plate (A) which causes a swirling action. Liquids and coarse particles are forced to the bowl interior wall (B) by the centrifugal action of the swirling air. They are then carried down the bowl wall by the force of gravity. The baffle (D) separates the lower portion of the bowl into a “quiet zone” (E) where the removed liquid and particles collect, unaffected by the swirling air, and are therefore not reentrained into the flowing air.

Second Stage Filtration:

After liquids and large particles are removed in the first stages of filtration, the air flows through element (C) where smaller particles are filtered out. The filtered air then passes downstream. Collected liquids and particles in the “quiet zone” (E) should be drained before their level reaches a height where they would be reentrained in the flowing air. This can be accomplished by unscrewing the drain valve (F) slightly until the liquid begins to drain.

Technical Information

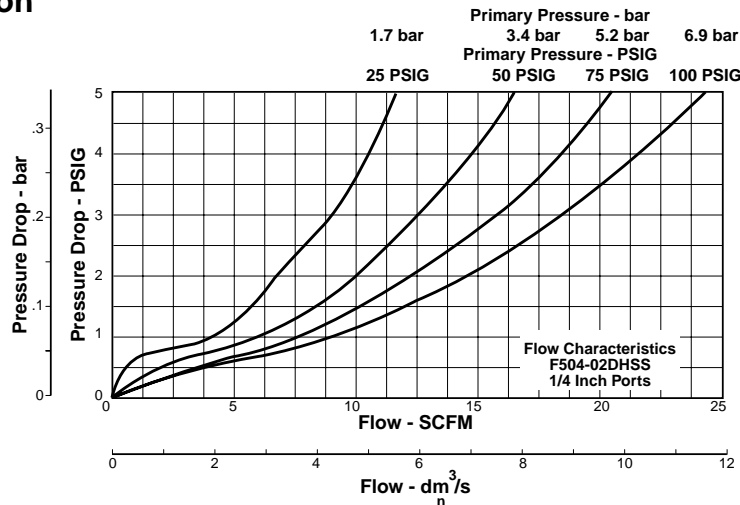

F504 Filter Kits & Accessories

- Drain Kits –**
 Automatic Pulse Drain RK504SY-SS
 Manual Twist Drain–
 Small (Old) SA600Y7-1SS
 Large (New) SAP05481
- Filter Element Kits –**
 Particulate (5 Micron) EK504VY
 Particulate (20 Micron) EK504Y
- Pipe Nipple –**
 1/4" 316 Stainless Steel 616Y28-SS

Specifications

- Bowl Capacity** 1.0 Ounces
Filter Rating 20 Micron
Sump Capacity 0.4 Ounce
Port Threads 1/4 Inch

Pressure & Temperature Ratings –

- Manual Twist Drain 0 to 300 PSIG (0 to 20.7 bar)
 0°F to 180°F (-18°C to 82°C)
 Auto Pulse Drain..... 10 to 175 PSIG (0 to 12 bar)
 32°F to 150°F (0°C to 66°C)

Note: Air must be dry enough to avoid ice formation at temperatures below 32°F (0°C)

Weight 0.6 lb. (0.27 kg)

Materials of Construction

- Body** 316 Stainless Steel
Bowls 316 Stainless Steel
Deflector Acetal
Drain 316 Stainless Steel
Element Holder Acetal
Filter Element Polyethylene
Seals Fluorocarbon

F10 Filter – Standard

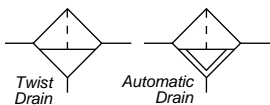

Features

- Stainless steel construction handles most corrosive environments.
- Meets NACE specifications MR-01-75/ISO 15156.
- 1/8" female threaded drain.
- High Flow: 1/2" - 70 SCFM[§]

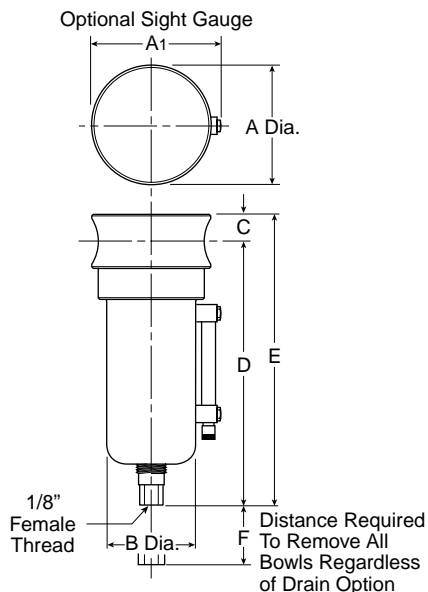

Port Size	NPT		BSPP	
	Manual Twist Drain	Automatic Float Drain	Manual Twist Drain	Automatic Float Drain
1/2"	F10-04WJSS	F10-04WJRSS	F10G04WJSS	F10G04WJRSS

F10 Filter Dimensions		
A 2.38 (60)	A1 2.50 (64)	B 1.75 (44)
C .56 (14)	D 5.00 (127)	E 5.56 (141)
F 2.12 (54)		

inches
(mm)

Standard part numbers shown bold.
 For other models refer to ordering information below.
 SCFM = Standard cubic feet per minute at 90 PSIG inlet and 5 PSIG pressure drop.

Ordering Information

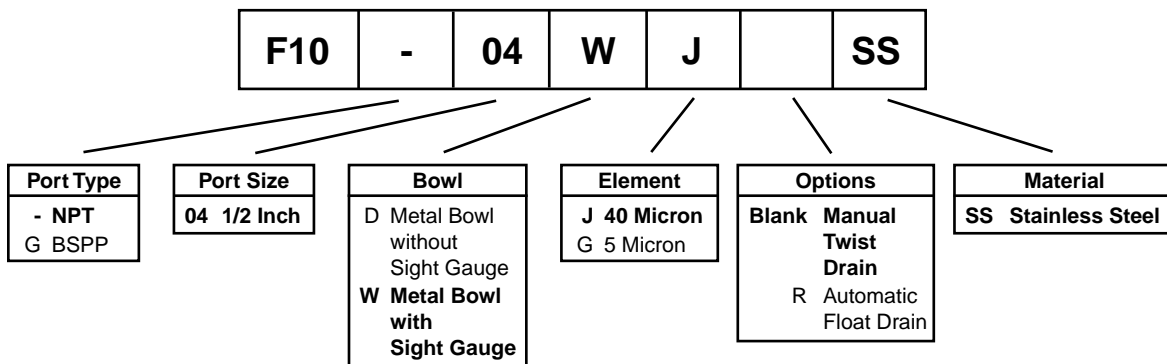

BOLD ITEMS ARE MOST POPULAR.



F501 Coalescing Filter – Miniature

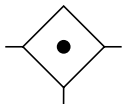

Features

- Stainless steel construction handles most corrosive environments.
- Meets NACE specifications MR-01-75/ISO 15156.
- 1/8" female threaded drain.
- High Flow: 1/4" - 16 SCFM[§]

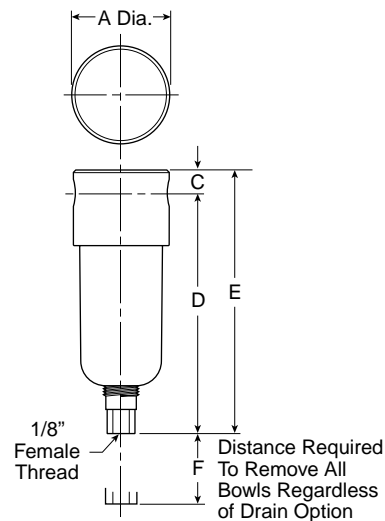

Port Size	NPT	BSP
	Manual Twist Drain	Manual Twist Drain
1/4"	F501-02DHSS	F501G02DHSS

Standard part numbers shown bold. For other models refer to ordering information below.

SCFM = Standard cubic feet per minute at 90 PSIG inlet and 5 PSIG pressure drop.

F501 Coalescing Filter Dimensions		
A	C	D
1.56 (40)	0.31 (8)	3.69 (94)
E	F	
4.00 (102)	1.58 (40)	

inches
(mm)

Ordering Information

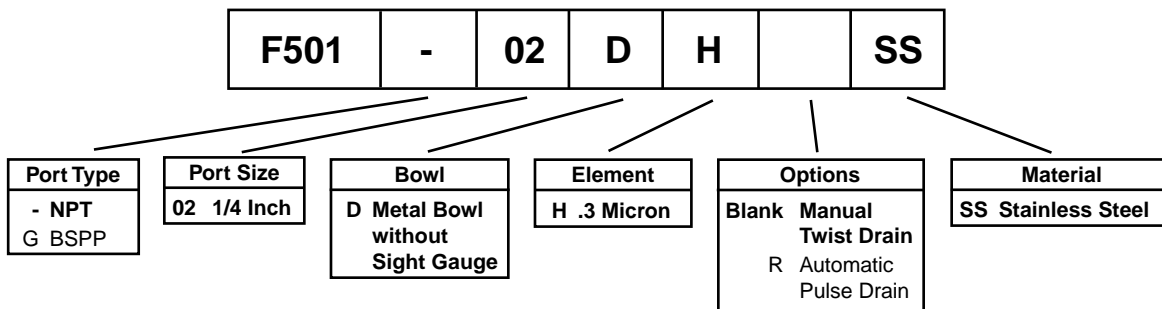

BOLD ITEMS ARE MOST POPULAR.

Operation

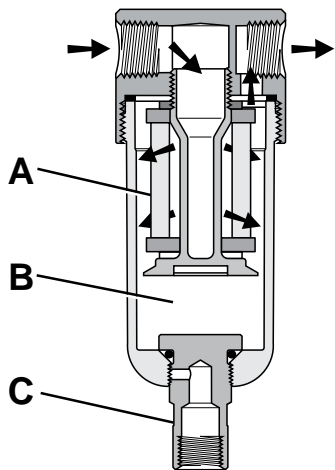

The contaminated air enters the element interior and is forced through a thick membrane (A) of "borosilicate" glass fibers coated with epoxy. Flow then passes through the element, and at this stage 99.97% of the sub micronic particles have been removed from the air stream. The tiny droplets coalesce together and are collected from the filter element by the outer drain layer. The clean, filtered air now passes through and out into the pneumatic system. The air line coalescing filter removes liquid aerosols and sub-micron particulate matter. Collected liquids and particles in the "quiet zone" (B) should be drained before their level reaches a height where they would be reentrained in the flowing air. This can be accomplished by unscrewing the drain valve (C) slightly until the liquid begins to drain.

Technical Information

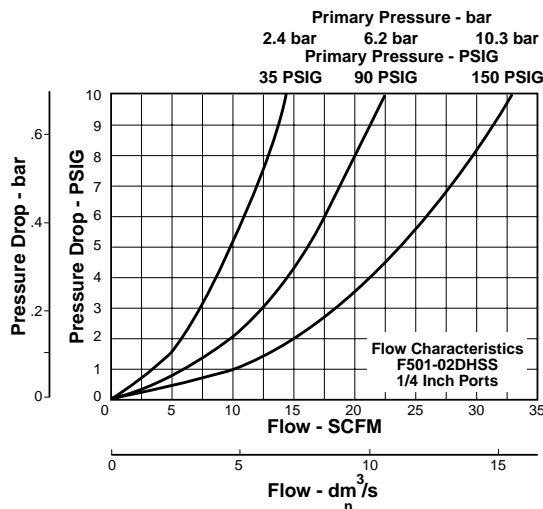

F501 Filter Kits & Accessories

- Drain Kits –
 - Automatic Pulse Drain RK504SY-SS
 - Manual Twist Drain –
 - Small (Old) SA600Y7-1SS
 - Large (New) SAP05481
- Filter Element Kits –
 - 0.1 Micron..... EKF501H
- Pipe Nipple –
 - 1/4" 316 Stainless Steel 616Y28-SS

Specifications

- Bowl Capacity 1.0 Ounces
- Filter Rating 0.3 Micron
- Port Threads 1/4 Inch

Pressure & Temperature Ratings –

- Manual Twist Drain 0 to 300 PSIG (0 to 20.7 bar)
0°F to 180°F (-18°C to 82°C)
- Auto Pulse Drain..... 10 to 175 PSIG (0 to 12 bar)
32°F to 150°F (0°C to 66°C)

Note: Air must be dry enough to avoid ice formation at temperatures below 32°F (0°C)

- Sump Capacity 0.4 Ounce
- Weight 0.6 lb. (0.27 kg)

Materials of Construction

- Body 316 Stainless Steel
- Bowls 316 Stainless Steel
- Drain 316 Stainless Steel
- Element Holder Acetal
- Filter Element Borosilicate Fiber
- Seals Fluorocarbon

F11 Coalescing Filter – Standard

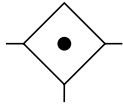

Features

- Stainless steel construction handles most corrosive environments.
- Meets NACE specifications MR-01-75/ISO 15156.
- 1/8" female threaded drain.
- High Flow: 1/2" - 45 SCFM[§]

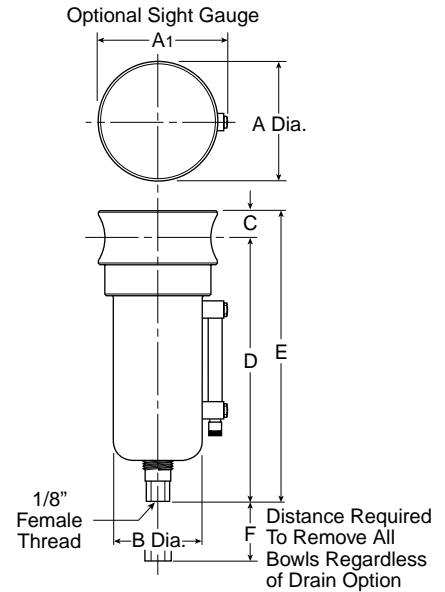

Port Size	NPT		BSPP	
	Manual Twist Drain	Automatic Float Drain	Manual Twist Drain	Automatic Float Drain
1/2"	Metal Bowl With Sight Gauge			
	F11-04WJSS	F11-04WJRSS	F11G04WJSS	F11G04WJRSS

F11 Coalescing Filter Dimensions		
A	A1	B
2.38 (60)	2.50 (64)	1.75 (44)
C	D	E
0.56 (14)	5.00 (127)	5.56 (141)
F		
2.12 (54)		

Standard part numbers shown bold. For other models refer to ordering information below.

SCFM = Standard cubic feet per minute at 90 PSIG inlet and 5 PSIG pressure drop.

inches
(mm)

Ordering Information

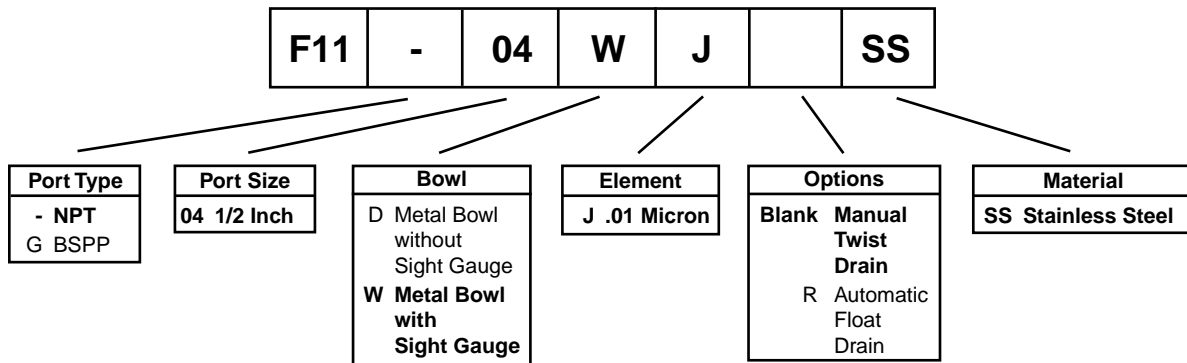

BOLD ITEMS ARE MOST POPULAR.

Operation

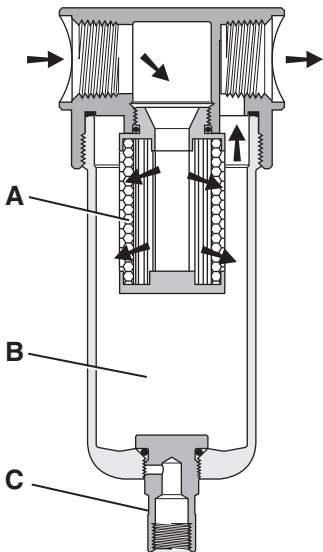

The contaminated air enters the element interior and is forced through a thick membrane (A) of “borosilicate” glass fibers coated with epoxy. Flow then passes through the element, and at this stage 99.9997% of the sub micronic particles have been removed from the air stream. The tiny droplets coalesce together and are collected from the filter element by the outer drain layer. The clean, filtered air now passes through and out into the pneumatic system. The air line coalescing filter removes liquid aerosols and sub-micron particulate matter. Collected liquids and particles in the “quiet zone” (B) should be drained before their level reaches a height where they would be reentrained in the flowing air. This can be accomplished by unscrewing the drain valve (C) slightly until the liquid begins to drain.

Technical Information

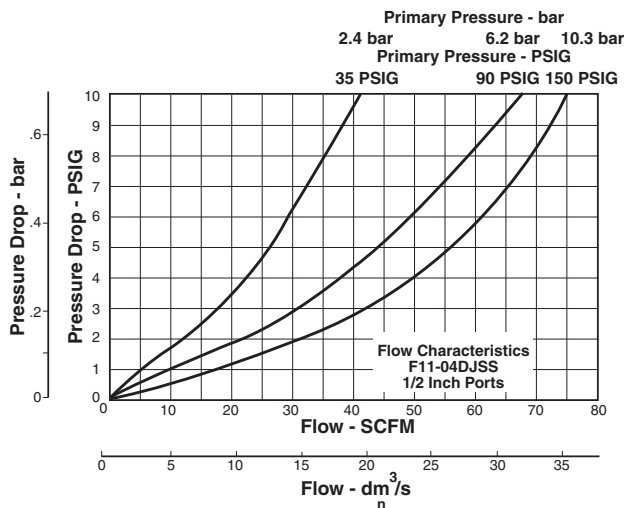

F11 Filter Kits & Accessories

- Drain Kits –**
- Automatic Float Drain SA10MDSS
- Filter Element Kits –**
- 0.01 Micron EKF71
- Pipe Nipple –**
- 1/2" 316 Stainless Steel 616A28-SS

Specifications

- Bowl Capacity** 4.0 Ounces
- Filter Rating** 0.01 Micron
- Sump Capacity** 1.7 Ounce
- Port Threads** 1/2 Inch
- Pressure & Temperature Ratings –**
- Manual Twist Drain 0 to 300 PSIG (0 to 20.7 bar)
0°F to 180°F (-18°C to 82°C)
- Manual Twist Drain (W) 0 to 250 PSIG (0 to 17.2 bar)
0°F to 150°F (-18°C to 66°C)

Automatic Float Drain 10 to 175 PSIG (0 to 12 bar)
32°F to 150°F (0°C to 66°C)

Note: Air must be dry enough to avoid ice formation at temperatures below 32°F (0°C)

Weight 1.9 lb. (0.85 kg)

Materials of Construction

- Body** 316 Stainless Steel
- Bowls** 316 Stainless Steel
- Drain** 316 Stainless Steel
- Element Holder** Acetal
- Filter Element** Borosilicate Fiber
- Seals** Fluorocarbon
- Sight Gauge** Isoplast

R354, R364 Regulator – Miniature

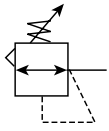

Features

- Stainless steel construction handles most corrosive environments.
- Large diaphragm to valve area ratio for precise regulation and high flow capacity.
- Meets NACE specifications MR-01-75/ISO 15156.
- High Flow: 1/4" – 12 SCFM[§]



R364



R354

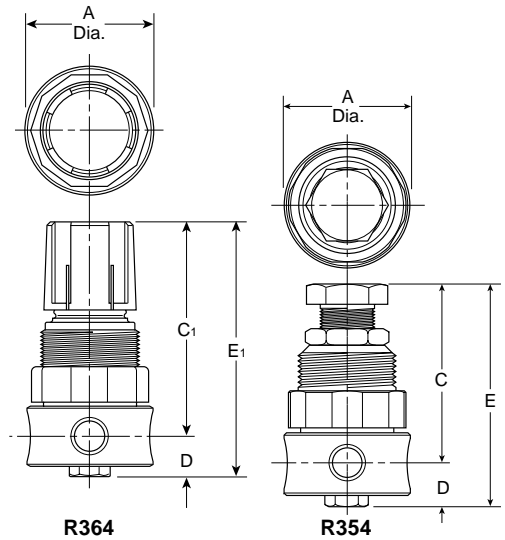

Series	Adjustment Type	Port Size	NPT		BSP	
			NPT	BSP	BSP	BSP
R364	Knob	1/4"	R364-02CSS	R364G02CSS		
R354	All Metal	1/4"	R354-02CSS	R354G02CSS		

R354, R364 Regulator Dimensions		
A	C	C₁
1.56 (40)	2.00 (51)	2.56 (65)
D	E	E₁
0.50 (13)	2.50 (64)	3.06 (78)

Standard part numbers shown bold. For other models refer to ordering information below.

[§] SCFM = Standard cubic feet per minute at 100 PSIG inlet, 75 PSIG no flow secondary setting and 15 PSIG pressure drop.

inches (mm)
 NOTE: 1.25 Dia. (32mm) hole required for panel mounting.

⚠ WARNING
Product rupture can cause serious injury. Do not connect regulator to bottled gas. Do not exceed maximum primary pressure rating.

Ordering Information

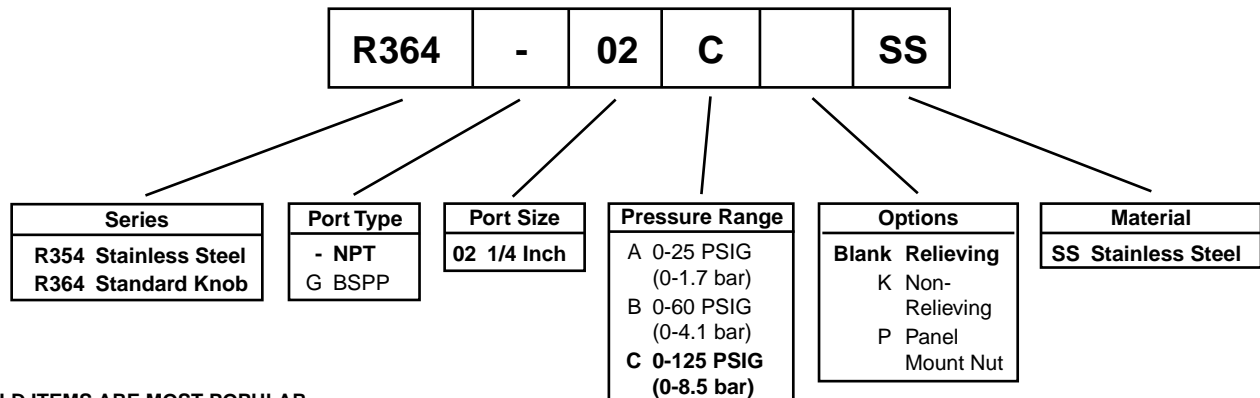

BOLD ITEMS ARE MOST POPULAR.

Technical Specifications – R354, R364

Operation

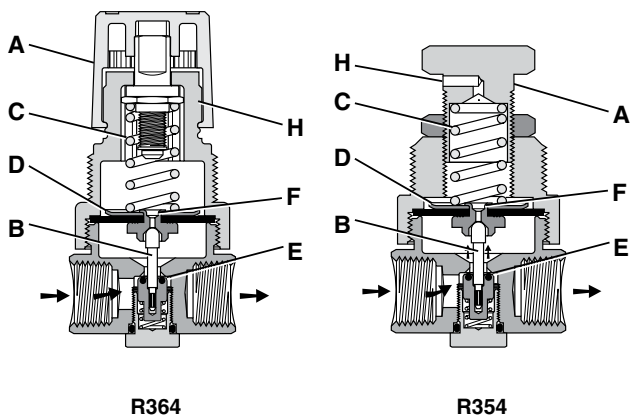

With the adjusting knob (A) turned fully counter-clockwise (no spring load), and pressure supplied to the regulator inlet port, the valve poppet assembly (B) is closed. Turning the adjusting knob clockwise applies a load to control spring (C). This load causes the diaphragm (D) and the valve poppet assembly (B) to move downward allowing flow across the seat area (E) created between the poppet assembly and the seat. Pressure in the downstream line is sensed below the diaphragm (D) and offsets the load of spring (C). As downstream pressure rises, poppet assembly (B) and diaphragm (D) move upward until the area (E) is closed and the load of the spring (C) and pressure under diaphragm (D) are in balance. A reduced outlet pressure has now been obtained, depending on spring load. Creating a demand downstream, such as opening a valve, results in a reduced pressure under the diaphragm (D). The load of control spring (C) now causes the poppet assembly to move downward opening seat area (E) allowing air to flow to meet the downstream demand. The flow of downstream air is metered by the amount of opening (E). Should downstream pressure exceed the desired regulated pressure, the excess pressure will cause the diaphragm (D) to move upward against control spring (C), open vent hole (F), and vent the excess pressure to atmosphere through the hole in the bonnet (H). (This occurs in the relieving type regulator only.)

Technical Information

CAUTION:

REGULATOR PRESSURE ADJUSTMENT –

The working range of knob adjustment is designed to permit outlet pressures within their full range. Pressure adjustment beyond this range is also possible because the knob is not a limiting device. This is a common characteristic of most industrial regulators, and limiting devices may be obtained only by special design.

For best performance, regulated pressure should always be set by increasing the pressure up to the desired setting.

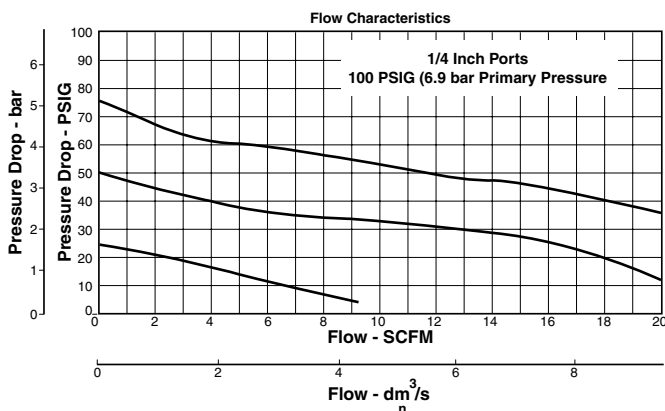

R354, R364 Regulator Kits & Accessories

- R354 Bonnet KitCKR354YSS
- R364 Bonnet Kit (Knob Included)CKR364Y-1SS
- Gauge (Stainless) –
160 PSIG (0 to 1100 kPa), 1-1/2" FaceK4515N14160SS
- Panel Mount Bracket (Stainless) 161X57-SS
- Panel Mount Nut –
Stainless R05X51-SS
PlasticR05X51-P
- Pipe Nipple –
1/4" 316 Stainless Steel 616Y28-SS
- Service Kit –
RelievingRKR364YSS
Non-Relieving RKR364KYSS
- Springs –
0-25 PSIG RangeSPR-375-2-SS
0-60 PSIG RangeSPR-376-1-SS
0-125 PSIG RangeSPR-377-1-SS

- Port Threads1/4 Inch
- Pressure & Temperature Ratings –
R354 300 PSIG Max (20.7 bar)
0°F to 180°F (-18°C to 82°C)
R364 300 PSIG Max (20.7 bar)
0°F to 150°F (-18°C to 66°C)

Note: Air must be dry enough to avoid ice formation at temperatures below 32°F (0°C)

Weight0.5 lb. (0.23 kg)

Materials of Construction

- Adjustment Mechanism / Springs316 Stainless Steel
- Adjusting Knob (R354)316 Stainless Steel
- Adjusting Knob (R364) Polypropylene
- Body316 Stainless Steel
- Bonnet (R354)316 Stainless Steel
- Bonnet (R364) Acetal
- Bottom Plug316 Stainless Steel
- Poppet316 Stainless Steel
- Seals Fluorocarbon

Specifications

- Gauge Port1/4 Inch
- OperationFluorocarbon Diaphragm



R10, R11 Regulator – Standard

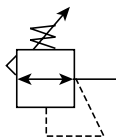

Features

- Stainless steel construction handles most corrosive environments.
- Large diaphragm to valve area ratio for precise regulation and high flow capacity.
- Meets NACE specifications MR-01-75/ISO 15156.
- Low temperature version available.
- High Flow: 1/2" – 80 SCFM[§]



R11



R10

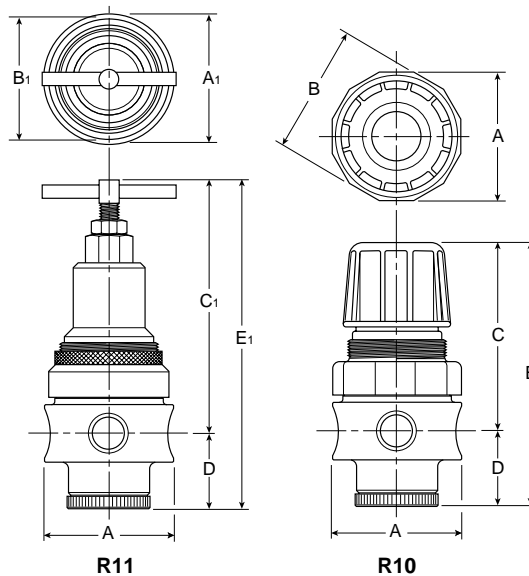

Series	Adjustment Type	Port Size	NPT	BSPB
R10	Knob	1/2"	R10-04CSS	R10G04CSS
R11	T-Handle	1/2"	R11-04CSS	R11G04CSS

R10, R11 Regulator Dimensions		
A	B	C
2.34 (60)	2.43 (62)	3.59 (91)
C₁	D	E
4.70 (119)	1.38 (35)	4.97 (126)
E₁		
6.08 (154)		

Standard part numbers shown bold. For other models refer to ordering information below.

[§] SCFM = Standard cubic feet per minute at 100 PSIG inlet, 75 PSIG no flow secondary setting and 15 PSIG pressure drop.

⚠ WARNING
Product rupture can cause serious injury. Do not connect regulator to bottled gas. Do not exceed maximum primary pressure rating.

inches (mm)
 NOTE: 1.75 Dia. (44mm) hole required for panel mounting.

Ordering Information

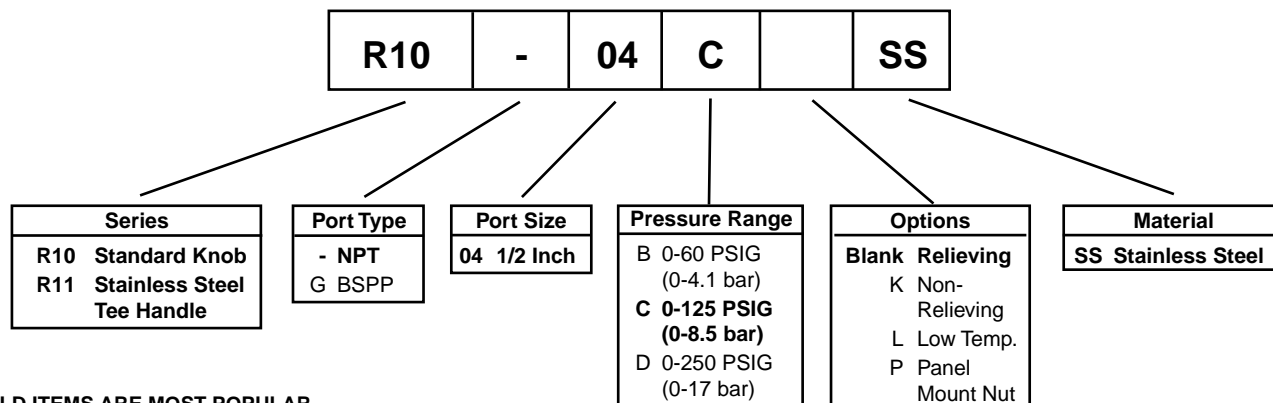

BOLD ITEMS ARE MOST POPULAR.



Operation

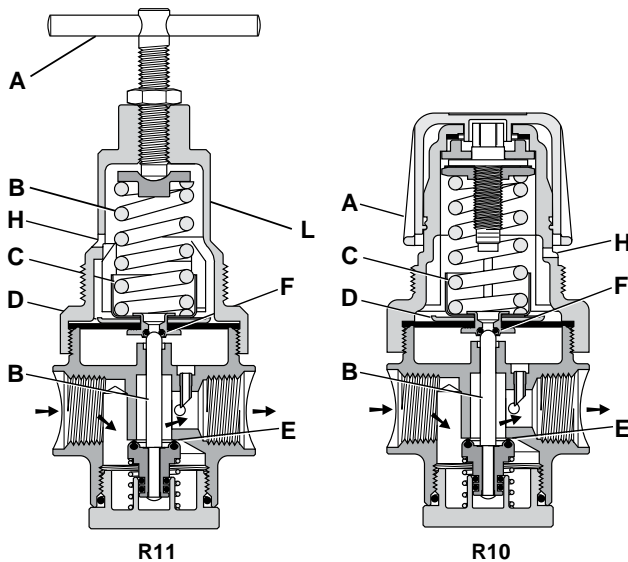

With the adjusting knob / T-Handle (A) turned fully counter-clockwise (no spring load), and pressure supplied to the regulator inlet port, the valve poppet assembly (B) is closed. Turning the adjusting knob clockwise applies a load to control spring (C). This load causes the diaphragm (D) and the valve poppet assembly (B) to move downward allowing flow across the seat area (E) created between the poppet assembly and the seat. Pressure in the downstream line is sensed below the diaphragm (D) and offsets the load of spring (C). As downstream pressure rises, poppet assembly (B) and diaphragm (D) move upward until the area (E) is closed and the load of the spring (C) and pressure under diaphragm (D) are in balance. A reduced outlet pressure has now been obtained, depending on spring load. Creating a demand downstream, such as opening a valve, results in a reduced pressure under the diaphragm (D). The load of control spring (C) now causes the poppet assembly to move downward opening seat area (E) allowing air to flow to meet the downstream demand. The flow of downstream air is metered by the amount of opening (E). Should downstream pressure exceed the desired regulated pressure, the excess pressure will cause the diaphragm (D) to move upward against control spring (C), open vent hole (F), and vent the excess pressure to atmosphere through the hole in the bonnet (H). (This occurs in the relieving type regulator only.)

Technical Information

CAUTION:

REGULATOR PRESSURE ADJUSTMENT –

The working range of knob adjustment is designed to permit outlet pressures within their full range. Pressure adjustment beyond this range is also possible because the knob is not a limiting device. This is a common characteristic of most industrial regulators, and limiting devices may be obtained only by special design.

For best performance, regulated pressure should always be set by increasing the pressure up to the desired setting.

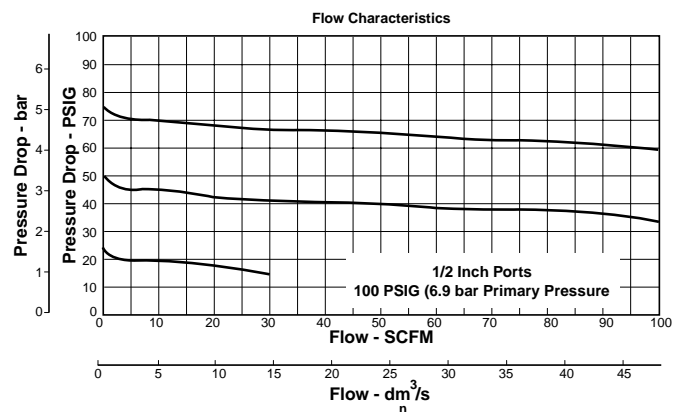

R10, R11 Regulator Kits & Accessories

- R10 Bonnet Kit (Knob Included)CKR10YSS
- R11 Bonnet Kit.....CKR11YSS
- Gauge (Stainless) –
- 160 PSIG (0 to 1100 kPa), 2" FaceK4520N14160SS
- Panel Mount Bracket (Stainless)..... R10Y57-SS
- Panel Mount Nut –
- Stainless R10X51-SS
- Plastic.....R10X51-P
- Pipe Nipple –
- 1/2" 316 Stainless Steel 616A28-SS
- Service Kit –
- Relieving.....RKR10YSS
- Non-Relieving..... RKR10KYSS
- Springs –
- 0-60 PSIG RangeSPR-388-1-SS
- 0-125 PSIG Range.....SPR-389-1-SS
- 0-250 PSIG Range.....SPR-390-1-SS

Pressure & Temperature Ratings –

- R10 300 PSIG Max (20.7 bar)
- 0°F to 150°F (-18°C to 66°C)
- R11 300 PSIG Max (20.7 bar)
- 0°F to 180°F (-18°C to 82°C)
- Option "L" Minimum Operating Temperature†..... -40° C/F

Note: Air must be dry enough to avoid ice formation at temperatures below 32°F (0°C)

Weight 1.79 lb. (0.81 kg)

Materials of Construction

- Adjustment Mechanism / Springs316 Stainless Steel
- Body316 Stainless Steel
- Bonnet / Tee Handle (R11).....316 Stainless Steel
- Bonnet / Knob (R10) Acetal
- Bottom Plug316 Stainless Steel
- Poppet316 Stainless Steel
- Seals Fluorocarbon

† **Note:** "Low Temperature" option is intended for applications where the ambient temperature may be down to -40° C/F. Air supply must be free of moisture to prevent ice formation and malfunction of units. These units contain EPDM seals. Make sure any oils in the airstream are compatible.

Specifications

- Gauge Port1/4 Inch
- OperationFluorocarbon Diaphragm
- Port Threads 1/2 Inch



B548, B558 Filter / Regulator – Miniature

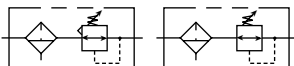

Features

- Stainless steel construction handles most corrosive environments.
- Large diaphragm to valve area ratio for precise regulation and high flow capacity.
- 1/8" female threaded drain.
- Meets NACE specifications MR-01-75/ISO 15156.
- High Flow: 1/4" – 12 SCFM[§]



B548



B558

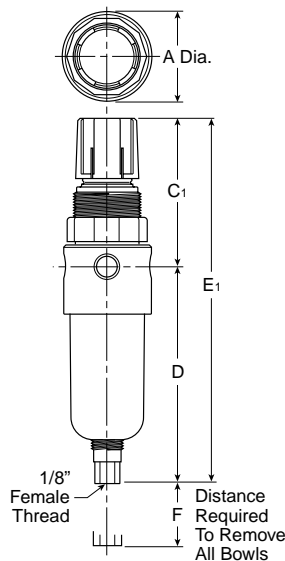

B548

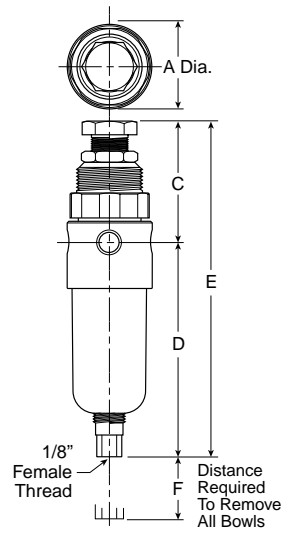

B558

Series	Adjustment Type	Port Size	NPT	BSPP
B548	Knob	1/4"	B548-02DHCSS	B548G02DHCSS
B558	All Metal	1/4"	B558-02DHCSS	B558G02DHCSS

B548, B558 Filter / Regulator Dimensions		
A 1.56 (40)	C 2.17 (55)	C₁ 2.63 (67)
D 3.63 (92)	E 5.80 (147)	E₁ 6.26 (159)
F 1.58 (40)		

Standard part numbers shown bold. For other models refer to ordering information below.

[§] SCFM = Standard cubic feet per minute at 100 PSIG inlet, 75 PSIG no flow secondary setting and 15 PSIG pressure drop.

⚠ WARNING
Product rupture can cause serious injury. Do not connect regulator to bottled gas. Do not exceed maximum primary pressure rating.

inches (mm)
 NOTE: 1.25 Dia. (32mm) hole required for panel mounting.

Ordering Information

B548							-	02		D	H	C			SS
-------------	--	--	--	--	--	--	---	-----------	--	----------	----------	----------	--	--	-----------

Series B548 Standard Knob B558 Stainless Steel	Port Type - NPT G BSPP	Port Size 02 1/4 Inch	Bowl D Metal Bowl without Sight Gauge	Element H 20 Micron G 5 Micron	Reduced Pressure Range A 0-25 PSIG (0-1.7 bar) B 0-60 PSIG (0-4.1 bar) C 0-125 PSIG (0-8.5 bar)	Options Blank Relieving K Non-Relieving R Automatic Pulse Drain P Panel Mount Nut	Material SS Stainless Steel
---	-------------------------------------	---------------------------------	---	---	--	--	---------------------------------------

BOLD ITEMS ARE MOST POPULAR.



Technical Specifications – B548, B558

Operation

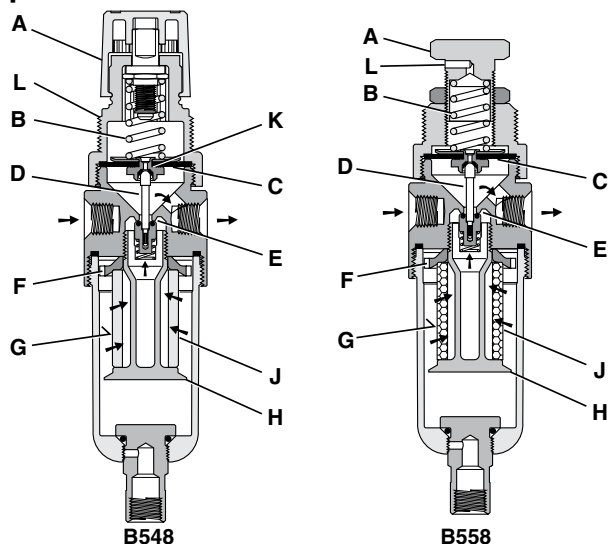

Turning the adjusting knob (A) clockwise applies a load to control spring (B) which forces diaphragm (C) and valve poppet assembly (D) to move downward allowing filtered air to flow through the seat area (E) created between the poppet assembly and the seat. “**First stage filtration**”. Air pressure supplied to the inlet port is directed through deflector plate (F) causing a swirling centrifugal action forcing liquids and coarse particles to the inner bowl wall (G) and down below the lower baffle (H) to the quiet zone. After liquids and large particles are removed in the first stage of filtration “**second stage filtration**” occurs as air flows through element (J) where smaller particles are filtered out and retained. The air flow now passes through seat area (E) to the outlet port of the unit. Pressure in the downstream line is sensed below the diaphragm (C) and offsets the load of spring (B). When downstream pressure reaches the set-point, poppet valve assembly (D) and diaphragm (C) move upward closing seat area (E). Should downstream pressure exceed the desired regulated pressure, the excess pressure will cause the diaphragm (C) to move upward opening vent hole (K) venting the excess pressure to atmosphere through the hole in the bonnet (L). (This occurs in the standard relieving type filter/regulators only.)

Technical Information

CAUTION:

REGULATOR PRESSURE ADJUSTMENT – The working range of knob adjustment is designed to permit outlet pressures within their full range. Pressure adjustment beyond this range is also possible because the knob is not a limiting device. This is a common characteristic of most industrial regulators, and limiting devices may be obtained only by special design.

For best performance, regulated pressure should always be set by increasing the pressure up to the desired setting.

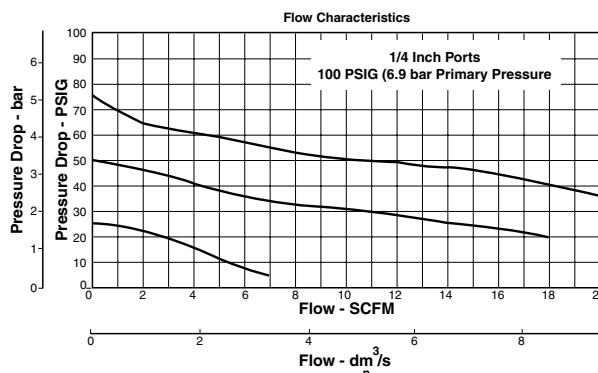

B548, B558 Regulator Kits & Accessories

- B558 Bonnet Kit (Knob Included)CKR354YSS
- B548 Bonnet Kit (Knob Included)CKR364Y-1SS
- Drain Kit –
 - Automatic Pulse Drain RK504SY-SS
 - Manual Twist Drain–
 - Small (Old) SA600Y7-1SS
 - Large (New) SAP05481
- Filter Element Kits –
 - Particulate (5 Micron) EK504VY
 - Particulate (20 Micron) EK504Y
- Gauge (Stainless) –
 - 160 PSIG (0 to 1100 kPa), 1-1/2" FaceK4515N14160SS
- Panel Mount Bracket (Stainless) 161X57-SS
- Panel Mount Nut –
 - Stainless R05X51-SS
 - Plastic R05X51-P
- Pipe Nipple –
 - 1/4" 316 Stainless Steel 616Y28-SS
- Service Kit –
 - Relieving RK549YSS
 - Non-Relieving RK548YSS
- Springs –
 - 0-25 PSIG Range SPR-375-2-SS
 - 0-60 PSIG Range SPR-376-1-SS
 - 0-125 PSIG Range SPR-377-1-SS

- Filter Rating20 Micron
- Gauge Port1/4 Inch
- OperationFluorocarbon Diaphragm
- Port Threads1/4 Inch
- Pressure & Temperature Ratings –
 - B548300 PSIG Max. (20.7 bar)
0°F to 150°F (-18°C to 82°C)
 - B558300 PSIG Max. (20.7 bar)
0°F to 180°F (-18°C to 82°C)
 - Auto Pulse Drain 10 to 175 PSIG (0 to 12 bar)
32°F to 150°F (0°C to 66°C)

Note: Air must be dry enough to avoid ice formation at temperatures below 32°F (2°C)

- Sump Capacity0.4 Ounce
- Weight0.6 lb. (0.27 kg)

Materials of Construction

- Adjustment Mechanism / Springs316 Stainless Steel
- Body316 Stainless Steel
- Bonnet (B548) Acetal
- Bonnet (B558)316 Stainless Steel
- Bottom Plug316 Stainless Steel
- Knob (B548) Polypropylene
- Knob (B558)316 Stainless Steel
- Poppet316 Stainless Steel
- Seals Fluorocarbon

Specifications

- Bowl Capacity 1.0 Ounces



B11, B12 Filter / Regulator – Standard

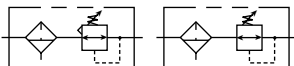

Features

- Stainless steel construction handles most corrosive environments.
- Large diaphragm to valve area ratio for precise regulation and high flow capacity.
- 1/8" female threaded drain.
- Meets NACE specifications MR-01-75/ISO-15156.
- Low temperature version available.
- High Flow: 1/2" – 72 SCFM[§]



B11

B12

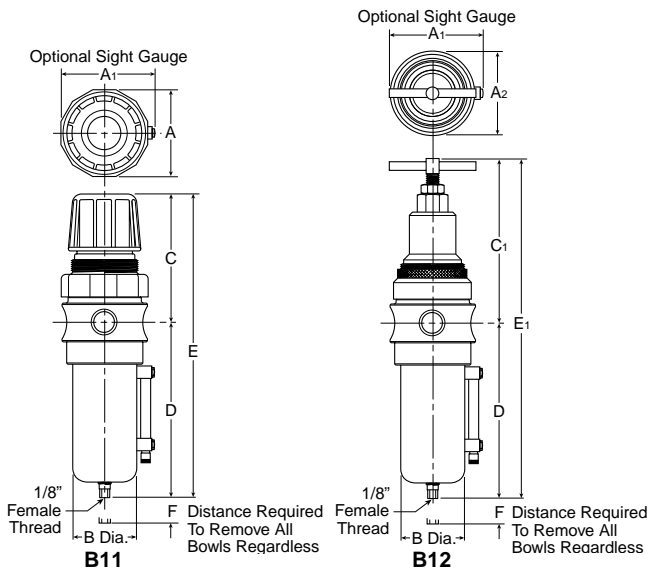

Series	Adjustment Type	Port Size	NPT		BSPB	
			Manual Twist Drain	Automatic Float Drain	Manual Twist Drain	Automatic Float Drain
			Metal Bowl with Sight Gauge			
B11	Knob	1/2"	B11-04WJCSS	B11-04WJCRSS	B11G04WJCSS	B11G04WJCRSS
B12	Tee-Handle	1/2"	B12-04WJCSS	B12-04WJCRSS	B12G04WJCSS	B12G04WJCRSS

B11, B12 Filter / Regulator Dimensions		
A 2.34 (60)	A1 2.50 (64)	B 1.75 (44)
C 3.59 (91)	C1 4.70 (119)	D 5.00 (127)
E 8.59 (218)	E1 9.70 (246)	F 2.12 (54)

Standard part numbers shown bold. For other models refer to ordering information below.

[§] SCFM = Standard cubic feet per minute at 100 PSIG inlet, 90 PSIG no flow secondary setting and 15 PSIG pressure drop.

⚠ WARNING
Product rupture can cause serious injury. Do not connect regulator to bottled gas. Do not exceed maximum primary pressure rating.

inches (mm)
 NOTE: 1.75 Dia. (44mm) hole required for panel mounting.

Ordering Information

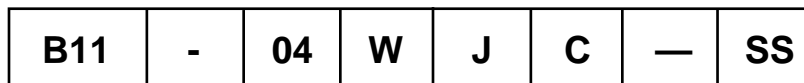

Series	Port Type	Bowl	Element	Reduced Pressure Range	Options	Material
B11 Standard Knob B12 Stainless Steel	- NPT G BSPB Port Size 04 1/2 Inch	D Metal Bowl without Sight Gauge W Metal Bowl with Sight Gauge	J 40 Micron G 5 Micron	B 0-60 PSIG (0-4.1 bar) C 0-125 PSIG (0-8.5 bar) D 0-250 PSIG (0-17 bar)	Blank Relieving K Non-Relieving P Panel Mount Nut R Automatic Float Drain L* Low Temp.	SS Stainless Steel

* Manual Drain and Without Sight Gauge Only.

BOLD ITEMS ARE MOST POPULAR.



Operation

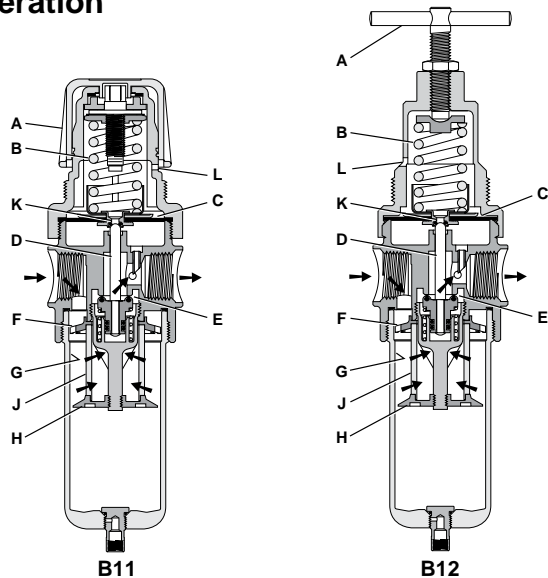

Turning the adjusting knob / T-Handle (A) clockwise applies a load to control spring (B) which forces diaphragm (C) and valve poppet assembly (D) to move downward allowing filtered air to flow through the seat area (E) created between the poppet assembly and the seat. “**First stage filtration**”.

Air pressure supplied to the inlet port is directed through deflector plate (F) causing a swirling centrifugal action forcing liquids and coarse particles to the inner bowl wall (G) and down below the lower baffle (H) to the quiet zone. After liquids and large particles are removed in the first stage of filtration “**second stage filtration**” occurs as air flows through element (J) where smaller particles are filtered out and retained. The air flow now passes through seat area (E) to the outlet port of the unit. Pressure in the downstream line is sensed below the diaphragm (C) and offsets the load of spring (B). When downstream pressure reaches the set-point, poppet valve assembly (D) and diaphragm (C) move upward closing seat area (E). Should downstream pressure exceed the desired regulated pressure, the excess pressure will cause the diaphragm (C) to move upward opening vent hole (K) venting the excess pressure to atmosphere through the hole in the bonnet (L). (This occurs in the standard relieving type filter/regulators only.)

Technical Information

CAUTION:

REGULATOR PRESSURE ADJUSTMENT – The working range of knob adjustment is designed to permit outlet pressures within their full range. Pressure adjustment beyond this range is also possible because the knob is not a limiting device. This is a common characteristic of most industrial regulators, and limiting devices may be obtained only by special design.

For best performance, regulated pressure should always be set by increasing the pressure up to the desired setting.

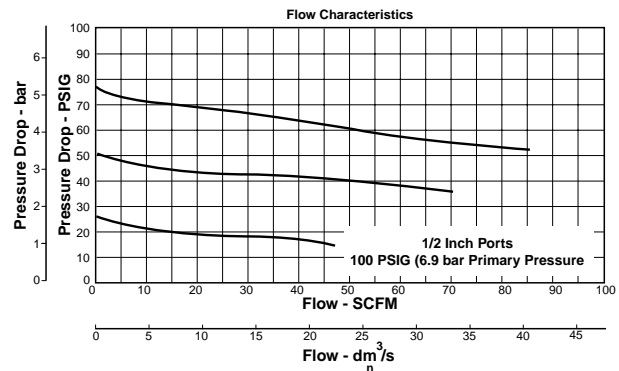

B11, B12 Regulator Kits & Accessories

- B11 Bonnet Kit (Knob Included)CKR10YSS
- B12 Bonnet KitCKR11YSS
- Drain Kit –
 - Automatic Float Drain SA10MDSS
 - Manual Twist Drain–
 - Small (Old) SA600Y7-1SS
 - Large (New) SAP05481
- Filter Element Kits –
 - Particulate (40 Micron) EKF10Y
 - Particulate (5 Micron) EKF10VY
- Gauge (Stainless) –
 - 160 PSIG (0 to 1100 kPa), 2" FaceK4520N14160SS
- Panel Mount Bracket (Stainless) R10Y57-SS
- Panel Mount Nut –
 - Stainless R10X51-SS
 - Plastic.....R10X51-P
- Pipe Nipple –
 - 1/2" 316 Stainless Steel 616A28-SS
- Service Kit –
 - RelievingRKR10YSS
 - Non-Relieving RKR10KYSS
- Springs –
 - 0-60 PSIG RangeSPR-388-1-SS
 - 0-125 PSIG RangeSPR-389-1-SS
 - 0-250 PSIG RangeSPR-390-1-SS

- Gauge Port 1/4 Inch
- Operation Fluorocarbon Diaphragm
- Port Threads 1/2 Inch
- Pressure & Temperature Ratings –
 - B11 (Metal Bowl D or W)300 PSIG Max (20.7 bar)
 - 0°F to 150°F (-18°C to 66°C)
 - B12 (Metal Bowl D).....300 PSIG Max (20.7 bar)
 - 0°F to 180°F (-18°C to 82°C)
 - B12 (Metal Bowl W)300 PSIG Max (20.7 bar)
 - 0°F to 150°F (-18°C to 66°C)
 - Automatic Float Drain15 to 175 PSIG (1 to 12 bar)
 - 32°F to 150°F (0°C to 66°C)
 - Option “L” Minimum Operating Temperature† -40° C/F

Note: Air must be dry enough to avoid ice formation at temperatures below 32°F (0°C).

- Sump Capacity 1.7 Ounce
- Weight 2.42 lb. (1.09 kg)

Materials of Construction

- Adjustment Mechanism / Springs 316 Stainless Steel
- Body 316 Stainless Steel
- Bonnet / Knob (B11) Acetal
- Bonnet / Tee Handle (B12) 316 Stainless Steel
- Bottom Plug 316 Stainless Steel
- Poppet 316 Stainless Steel
- Seals Fluorocarbon
- Sight Gauge Isoplast

Specifications

- Bowl Capacity 4.0 Ounces
- Filter Rating40 Micron



L10 Lubricator – Standard



Features

- Stainless Steel Construction Handles Most Corrosive Environments
- 1/8" Female Threaded Drain
- Fillable Under Pressure
- Meets NACE Specifications MR-01-75/ISO 15156
- High Flow: 1/2" - 100 SCFM[§]

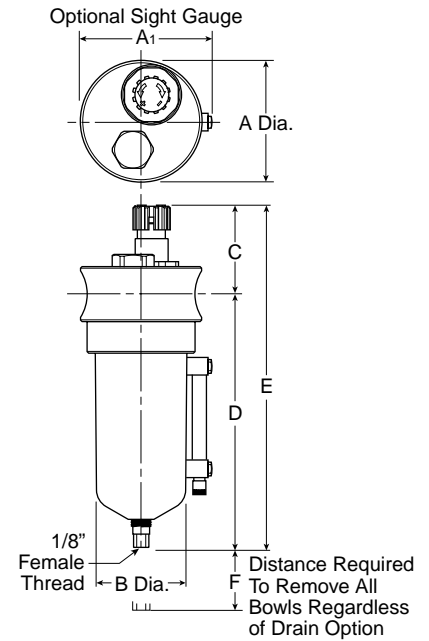

Port Size	NPT	BSP
	Manual Twist Drain	Manual Twist Drain
1/2"	Metal Bowl With Sight Gauge	
	L10-04WSS	L10G04WSS

L10 Lubricator Dimensions		
A	A1	B
2.36 (60)	2.52 (64)	1.73 (44)
C	D	E
2.17 (55)	5.46 (139)	7.62 (194)
F		
3.50 (89)		

Standard part numbers shown bold. For other models refer to ordering information below.

§ SCFM = Standard cubic feet per minute at 90 PSIG inlet and 5 PSIG pressure drop.

inches
(mm)

Ordering Information

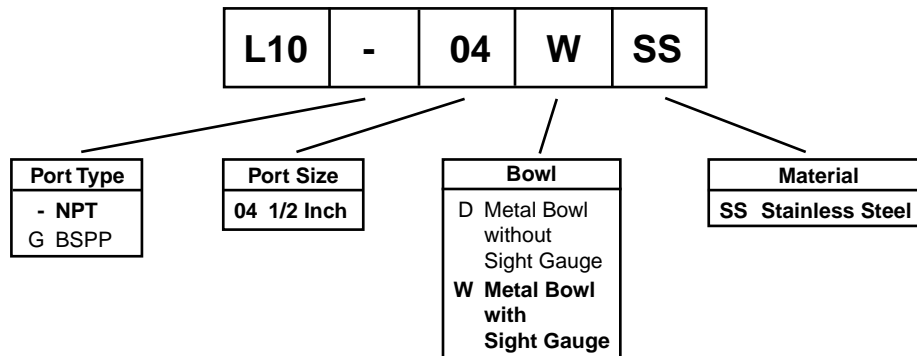

BOLD ITEMS ARE MOST POPULAR.

Operation

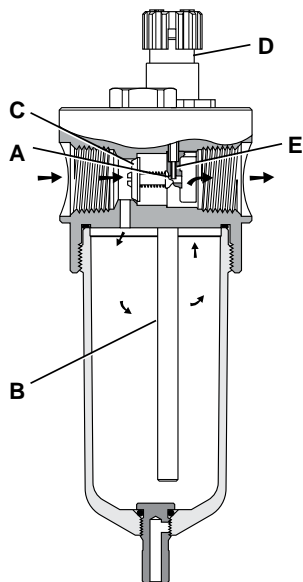

Air flowing through the unit goes through two paths. At low flow rates the majority of the air flows through the Venturi section (A). The rest of the air opens the check valve (C). The velocity of the air flowing through the Venturi section (A) creates a pressure drop. This lower pressure allows the oil to be forced from the reservoir through the pickup tube (B) and travels up to the metering screw (D). The rate of oil delivery is then controlled by adjusting the metering screw (D). Oil flows past the metering screw (D) and forms a drop in the nozzle tube (E). As the oil drops through the dome (F) and back into the Venturi section (A), it is broken up into fine particles. It is then mixed with the air flowing past the check valve (C) and is carried downstream. As the air flow increases the check valve (C) will open more fully. This additional flow will assure that the oil delivery rate will increase linearly with the increase of air flow.

Technical Information

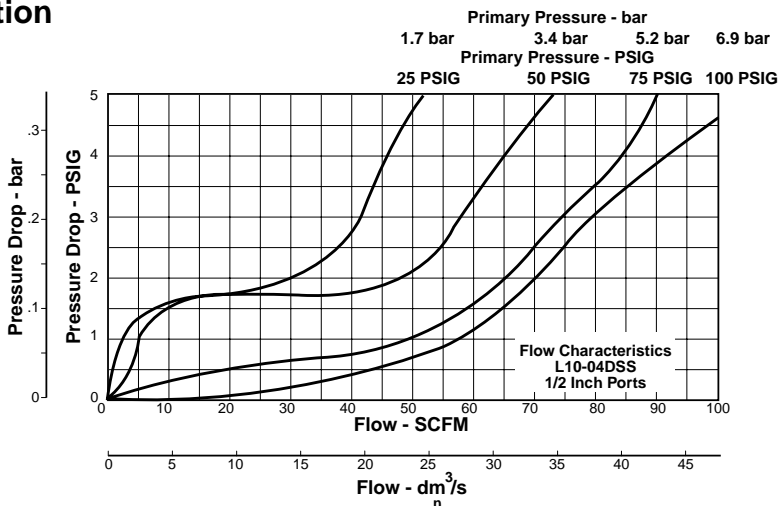

L10 Filter Kits & Accessories

- Drain Kit –
 - Manual Twist Drain –
 - Small (Old) SA600Y7-1SS
 - Large (New) SAP05481
- Pipe Nipple –
 - 1/2" 316 Stainless Steel 616A28-SS
- Sight Dome Kit –
 - (Old).....RKL10SS
 - (New).....PS740N

Specifications

- Bowl Capacity 4.0 Ounces
- Port Threads 1/2 Inch
- Pressure & Temperature Ratings –
 - Metal Bowl (D) 0 to 300 PSIG (0 to 20.7 bar)
0°F to 150°F (-18°C to 66°C)
 - Metal Bowl (W) 0 to 250 PSIG (0 to 17.2 bar)
0°F to 150°F (-18°C to 66°C)

Note: Air must be dry enough to avoid ice formation at temperatures below 32°F (0°C).

Weight 1.9 lb. (0.85 kg)

Materials of Construction

- Body 316 Stainless Steel
- Bowl 316 Stainless Steel
- Dip Tube 316 Stainless Steel
- Drain 316 Stainless Steel
- Fill Plug 316 Stainless Steel
- Seals Fluorocarbon
- Sight Dome Nylon
- Sight Gauge Isoplast

Safety Guide For Selecting And Using Pneumatic Division Products And Related Accessories

WARNING:

FAILURE OR IMPROPER SELECTION OR IMPROPER USE OF PNEUMATIC DIVISION PRODUCTS, ASSEMBLIES OR RELATED ITEMS (“PRODUCTS”) CAN CAUSE DEATH, PERSONAL INJURY, AND PROPERTY DAMAGE. POSSIBLE CONSEQUENCES OF FAILURE OR IMPROPER SELECTION OR IMPROPER USE OF THESE PRODUCTS INCLUDE BUT ARE NOT LIMITED TO:

- Unintended or mistimed cycling or motion of machine members or failure to cycle
- Work pieces or component parts being thrown off at high speeds.
- Failure of a device to function properly for example, failure to clamp or unclamp an associated item or device.
- Explosion
- Suddenly moving or falling objects.
- Release of toxic or otherwise injurious liquids or gasses.

Before selecting or using any of these Products, it is important that you read and follow the instructions below.

1. GENERAL INSTRUCTIONS

- 1.1. Scope:** This safety guide is designed to cover general guidelines on the installation, use, and maintenance of Pneumatic Division Valves, FRLs (Filters, Pressure Regulators, and Lubricators), Vacuum products and related accessory components.
- 1.2. Fail-Safe:** Valves, FRLs, Vacuum products and their related components can and do fail without warning for many reasons. Design all systems and equipment in a fail-safe mode, so that failure of associated valves, FRLs or Vacuum products will not endanger persons or property.
- 1.3. Relevant International Standards:** For a good guide to the application of a broad spectrum of pneumatic fluid power devices see: ISO 4414:1998, Pneumatic Fluid Power – General Rules Relating to Systems. See www.iso.org for ordering information.
- 1.4. Distribution:** Provide a copy of this safety guide to each person that is responsible for selection, installation, or use of Valves, FRLs or Vacuum products. Do not select, or use Parker valves, FRLs or vacuum products without thoroughly reading and understanding this safety guide as well as the specific Parker publications for the products considered or selected.
- 1.5. User Responsibility:** Due to the wide variety of operating conditions and applications for valves, FRLs, and vacuum products Parker and its distributors do not represent or warrant that any particular valve, FRL or vacuum product is suitable for any specific end use system. This safety guide does not analyze all technical parameters that must be considered in selecting a product. The user, through its own analysis and testing, is solely responsible for:
 - Making the final selection of the appropriate valve, FRL, Vacuum component, or accessory.
 - Assuring that all user's performance, endurance, maintenance, safety, and warning requirements are met and that the application presents no health or safety hazards.
 - Complying with all existing warning labels and / or providing all appropriate health and safety warnings on the equipment on which the valves, FRLs or Vacuum products are used; and,
 - Assuring compliance with all applicable government and industry standards.
- 1.6. Safety Devices:** Safety devices should not be removed, or defeated.
- 1.7. Warning Labels:** Warning labels should not be removed, painted over or otherwise obscured.
- 1.8. Additional Questions:** Call the appropriate Parker technical service department if you have any questions or require any additional information. See the Parker publication for the product being considered or used, or call 1-800-CPARKER, or go to www.parker.com, for telephone numbers of the appropriate technical service department.

2. PRODUCT SELECTION INSTRUCTIONS

- 2.1. Flow Rate:** The flow rate requirements of a system are frequently the primary consideration when designing any pneumatic system. System components need to be able to provide adequate flow and pressure for the desired application.
- 2.2. Pressure Rating:** Never exceed the rated pressure of a product. Consult product labeling, Pneumatic Division catalogs or the instruction sheets supplied for maximum pressure ratings.
- 2.3. Temperature Rating:** Never exceed the temperature rating of a product. Excessive heat can shorten the life expectancy of a product and result in complete product failure.
- 2.4. Environment:** Many environmental conditions can affect the integrity and suitability of a product for a given application. Pneumatic Division products are designed for use in general purpose industrial applications. If these products are to be used in unusual circumstances such as direct sunlight and/or corrosive or caustic environments, such use can shorten the useful life and lead to premature failure of a product.
- 2.5. Lubrication and Compressor Carryover:** Some modern synthetic oils can and will attack nitrile seals. If there is any possibility of synthetic oils or greases migrating into the pneumatic components check for compatibility with the seal materials used. Consult the factory or product literature for materials of construction.
- 2.6. Polycarbonate Bowls and Sight Glasses:** To avoid potential polycarbonate bowl failures:
 - Do not locate polycarbonate bowls or sight glasses in areas where they could be subject to direct sunlight, impact blow, or temperatures outside of the rated range.
 - Do not expose or clean polycarbonate bowls with detergents, chlorinated hydro-carbons, ketones, esters or certain alcohols.
 - Do not use polycarbonate bowls or sight glasses in air systems where compressors are lubricated with fire resistant fluids such as phosphate ester and di-ester lubricants.

2.7. Chemical Compatibility: For more information on plastic component chemical compatibility see Pneumatic Division technical bulletins Tec-3, Tec-4, and Tec-5

- 2.8. Product Rupture:** Product rupture can cause death, serious personal injury, and property damage.
- Do not connect pressure regulators or other Pneumatic Division products to bottled gas cylinders.
 - Do not exceed the maximum primary pressure rating of any pressure regulator or any system component.
 - Consult product labeling or product literature for pressure rating limitations.

3. PRODUCT ASSEMBLY AND INSTALLATION INSTRUCTIONS

3.1. Component Inspection: Prior to assembly or installation a careful examination of the valves, FRLs or vacuum products must be performed. All components must be checked for correct style, size, and catalog number. DO NOT use any component that displays any signs of nonconformance.

3.2. Installation Instructions: Parker published Installation Instructions must be followed for installation of Parker valves, FRLs and vacuum components. These instructions are provided with every Parker valve or FRL sold, or by calling 1-800-CPARKER, or at www.parker.com.

3.3. Air Supply: The air supply or control medium supplied to Valves, FRLs and Vacuum components must be moisture-free if ambient temperature can drop below freezing

4. VALVE AND FRL MAINTENANCE AND REPLACEMENT INSTRUCTIONS

4.1. Maintenance: Even with proper selection and installation, valve, FRL and vacuum products service life may be significantly reduced without a continuing maintenance program. The severity of the application, risk potential from a component failure, and experience with any known failures in the application or in similar applications should determine the frequency of inspections and the servicing or replacement of Pneumatic Division products so that products are replaced before any failure occurs. A maintenance program must be established and followed by the user and, at minimum, must include instructions 4.2 through 4.10.

4.2. Installation and Service Instructions: Before attempting to service or replace any worn or damaged parts consult the appropriate Service Bulletin for the valve or FRL in question for the appropriate practices to service the unit in question. These Service and Installation Instructions are provided with every Parker valve and FRL sold, or are available by calling 1-800-CPARKER, or by accessing the Parker web site at www.parker.com.

4.3. Lockout / Tagout Procedures: Be sure to follow all required lockout and tagout procedures when servicing equipment. For more information see: OSHA Standard – 29 CFR, Part 1910.147, Appendix A, The Control of Hazardous Energy – (Lockout / Tagout)

4.4. Visual Inspection: Any of the following conditions requires immediate system shut down and replacement of worn or damaged components:

- Air leakage: Look and listen to see if there are any signs of visual damage to any of the components in the system. Leakage is an indication of worn or damaged components.
- Damaged or degraded components: Look to see if there are any visible signs of wear or component degradation.
- Kinked, crushed, or damaged hoses. Kinked hoses can result in restricted air flow and lead to unpredictable system behavior.
- Any observed improper system or component function: Immediately shut down the system and correct malfunction.
- Excessive dirt build-up: Dirt and clutter can mask potentially hazardous situations.

Caution: Leak detection solutions should be rinsed off after use.

4.5. Routine Maintenance Issues:

- Remove excessive dirt, grime and clutter from work areas.
- Make sure all required guards and shields are in place.

4.6. Functional Test: Before initiating automatic operation, operate the system manually to make sure all required functions operate properly and safely.

4.7. Service or Replacement Intervals: It is the user's responsibility to establish appropriate service intervals. Valves, FRLs and vacuum products contain components that age, harden, wear, and otherwise deteriorate over time. Environmental conditions can significantly accelerate this process. Valves, FRLs and vacuum components need to be serviced or replaced on routine intervals. Service intervals need to be established based on:

- Previous performance experiences.
- Government and / or industrial standards.
- When failures could result in unacceptable down time, equipment damage or personal injury risk.

4.8. Servicing or Replacing of any Worn or Damaged Parts: To avoid unpredictable system behavior that can cause death, personal injury and property damage:

- Follow all government, state and local safety and servicing practices prior to service including but not limited to all OSHA Lockout Tagout procedures (OSHA Standard – 29 CFR, Part 1910.147, Appendix A, The Control of Hazardous Energy – Lockout / Tagout).
- Disconnect electrical supply (when necessary) before installation, servicing, or conversion.
- Disconnect air supply and depressurize all air lines connected to system and Pneumatic Division products before installation, service, or conversion.
- Installation, servicing, and / or conversion of these products must be performed by knowledgeable personnel who understand how pneumatic products are to be applied.
- After installation, servicing, or conversions air and electrical supplies (when necessary) should be connected and the product tested for proper function and leakage. If audible leakage is present, or if the product does not operate properly, do not put product or system into use.
- Warnings and specifications on the product should not be covered or painted over. If masking is not possible, contact your local representative for replacement labels.

4.9. Putting Serviced System Back into Operation: Follow the guidelines above and all relevant Installation and Maintenance Instructions supplied with the valve FRL or vacuum component to insure proper function of the system.

The items described in this document and other documents and descriptions provided by Parker Hannifin Corporation, its subsidiaries and its authorized distributors ("Seller") are hereby offered for sale at prices to be established by Seller. This offer and its acceptance by any customer ("Buyer") shall be governed by all of the following Terms and Conditions. Buyer's order for any item described in its document, when communicated to Seller verbally, or in writing, shall constitute acceptance of this offer. All goods or work described will be referred to as "Products".

1. Terms and Conditions. Seller's willingness to offer Products, or accept an order for Products, to or from Buyer is subject to these Terms and Conditions or any newer version of the terms and conditions found on-line at www.parker.com/saleterms/. Seller objects to any contrary or additional terms or conditions of Buyer's order or any other document issued by Buyer.

2. Price Adjustments; Payments. Prices stated on Seller's quote or other documentation offered by Seller are valid for 30 days, and do not include any sales, use, or other taxes unless specifically stated, Unless otherwise specified by Seller, all prices are F.C.A. Seller's facility (INCOTERMS 2010). Payment is subject to credit approval and is due 30 days from the date of invoice or such other term as required by Seller's Credit Department, after which Buyer shall pay interest on any unpaid invoices at the rate of 1.5% per month or the maximum allowable rate under applicable law.

3. Delivery Dates; Title and Risk; Shipment. All delivery dates are approximate and Seller shall not be responsible for any damages resulting from any delay. Regardless of the manner of shipment, title to any products and risk of loss or damage shall pass to Buyer upon placement of the products with the shipment carrier at Seller's facility. Unless otherwise stated, Seller may exercise its judgment in choosing the carrier and means of delivery. No deferral of shipment at Buyers' request beyond the respective dates indicated will be made except on terms that will indemnify, defend and hold Seller harmless against all loss and additional expense. Buyer shall be responsible for any additional shipping charges incurred by Seller due to Buyer's acts or omissions.

4. Warranty. Seller warrants that the Products sold hereunder shall be free from defects in material or workmanship for a period of twelve months from the date of delivery to Buyer or 2,000 hours of normal use, whichever occurs first. The prices charged for Seller's products are based upon the exclusive limited warranty stated above, and upon the following disclaimer: **DISCLAIMER OF WARRANTY: THIS WARRANTY COMPRISES THE SOLE AND ENTIRE WARRANTY PERTAINING TO PRODUCTS PROVIDED HEREUNDER. SELLER DISCLAIMS ALL OTHER WARRANTIES, EXPRESS AND IMPLIED, INCLUDING DESIGN, MERCHANTABILITY AND FITNESS FOR A PARTICULAR PURPOSE.**

5. Claims; Commencement of Actions. Buyer shall promptly inspect all Products upon delivery. No claims for shortages will be allowed unless reported to the Seller within 10 days of delivery. No other claims against Seller will be allowed unless asserted in writing within 30 days after delivery. Buyer shall notify Seller of any alleged breach of warranty within 30 days after the date the defect is or should have been discovered by Buyer. Any action based upon breach of this agreement or upon any other claim arising out of this sale (other than an action by Seller for an amount due on any invoice) must be commenced within 12 months from the date of the breach without regard to the date breach is discovered.

6. LIMITATION OF LIABILITY. UPON NOTIFICATION, SELLER WILL, AT ITS OPTION, REPAIR OR REPLACE A DEFECTIVE PRODUCT, OR REFUND THE PURCHASE PRICE. **IN NO EVENT SHALL SELLER BE LIABLE TO BUYER FOR ANY SPECIAL, INDIRECT, INCIDENTAL OR CONSEQUENTIAL DAMAGES ARISING OUT OF, OR AS THE RESULT OF, THE SALE, DELIVERY, NON-DELIVERY, SERVICING, USE OR LOSS OF USE OF THE PRODUCTS OR ANY PART THEREOF, OR FOR ANY CHARGES OR EXPENSES OF ANY NATURE INCURRED WITHOUT SELLER'S WRITTEN CONSENT, EVEN IF SELLER HAS BEEN NEGLIGENT, WHETHER IN CONTRACT, TORT OR OTHER LEGAL THEORY. IN NO EVENT SHALL SELLER'S LIABILITY UNDER ANY CLAIM MADE BY BUYER EXCEED THE PURCHASE PRICE OF THE PRODUCTS.**

7. User Responsibility. The user, through its own analysis and testing, is solely responsible for making the final selection of the system and Product and assuring that all performance, endurance, maintenance, safety and warning requirements of the application are met. The user must analyze all aspects of the application and follow applicable industry standards and Product information. If Seller provides Product or system options, the user is responsible for determining that such data and specifications are suitable and sufficient for all applications and reasonably foreseeable uses of the Products or systems.

8. Loss to Buyer's Property. Any designs, tools, patterns, materials, drawings, confidential information or equipment furnished by Buyer or any other items which become Buyer's property, may be considered obsolete and may be destroyed by Seller after two consecutive years have elapsed without Buyer ordering the items manufactured using such property. Seller shall not be responsible for any loss or damage to such property while it is in Seller's possession or control.

9. Special Tooling. A tooling charge may be imposed for any special tooling, including without limitation, dies, fixtures, molds and patterns, acquired to manufacture Products. Such special tooling shall be and remain Seller's property notwithstanding payment of any charges by Buyer. In no event will Buyer acquire any interest in apparatus belonging to Seller which is utilized in the manufacture of the Products, even if such apparatus has been specially converted or adapted for such manufacture and notwithstanding any charges paid by Buyer. Unless otherwise agreed, Seller shall have the right to alter, discard or otherwise dispose of any special tooling or other property in its sole discretion at any time.

10. Buyer's Obligation; Rights of Seller. To secure payment of all sums due or otherwise, Seller shall retain a security interest in the goods delivered and this agreement shall be deemed a Security Agreement under the Uniform Commercial Code. Buyer authorizes Seller as its attorney to execute and file on Buyer's behalf all documents Seller deems necessary to perfect its security interest.

11. Improper use and Indemnity. Buyer shall indemnify, defend, and hold Seller harmless from any claim, liability, damages, lawsuits, and costs (including attorney fees), whether for personal injury, property damage, patent, trademark or copyright

infringement or any other claim, brought by or incurred by Buyer, Buyer's employees, or any other person, arising out of: (a) improper selection, improper application or other misuse of Products purchased by Buyer from Seller; (b) any act or omission, negligent or otherwise, of Buyer; (c) Seller's use of patterns, plans, drawings, or specifications furnished by Buyer to manufacture Product; or (d) Buyer's failure to comply with these terms and conditions. Seller shall not indemnify Buyer under any circumstance except as otherwise provided.

12. Cancellations and Changes. Orders shall not be subject to cancellation or change by Buyer for any reason, except with Seller's written consent and upon terms that will indemnify, defend and hold Seller harmless against all direct, incidental and consequential loss or damage. Seller may change product features, specifications, designs and availability with notice to Buyer.

13. Limitation on Assignment. Buyer may not assign its rights or obligations under this agreement without the prior written consent of Seller.

14. Force Majeure. Seller does not assume the risk and shall not be liable for delay or failure to perform any of Seller's obligations by reason of circumstances beyond the reasonable control of Seller (hereinafter "Events of Force Majeure") Events of Force Majeure shall include without limitation: accidents, strikes or labor disputes, acts of any government or government agency, acts of nature, delays or failures in delivery from carriers or suppliers, shortages of materials, or any other cause beyond Seller's reasonable control.

15. Waiver and Severability. Failure to enforce any provision of this agreement will not waive that provision nor will any such failure prejudice Seller's right to enforce that provision in the future. Invalidation of any provision of this agreement by legislation or other rule of law shall not invalidate any other provision herein. The remaining provisions of this agreement will remain in full force and effect.

16. Termination. Seller may terminate this agreement for any reason and at any time by giving Buyer thirty (30) days written notice of termination. Seller may immediately terminate this agreement, in writing, if Buyer: (a) commits a breach of any provision of this agreement (b) appoints a trustee, receiver or custodian for all or any part of Buyer's property (c) files a petition for relief in bankruptcy on its own behalf, or by a third party (d) makes an assignment for the benefit of creditors, or (e) the dissolves or liquidates all or a majority of its assets.

17. Governing Law. This agreement and the sale and delivery of all Products hereunder shall be deemed to have taken place in and shall be governed and construed in accordance with the laws of the State of Ohio, as applicable to contracts executed and wholly performed therein and without regard to conflicts of laws principles. Buyer irrevocably agrees and consents to the exclusive jurisdiction and venue of the courts of Cuyahoga County, Ohio with respect to any dispute, controversy or claim arising out of or relating to this agreement.

18. Indemnity for Infringement of Intellectual Property Rights. Seller shall have no liability for infringement of any patents, trademarks, copyrights, trade dress, trade secrets or similar rights except as provided in this Section. Seller will defend and indemnify Buyer against allegations of infringement of U.S. patents, U.S. trademarks, copyrights, trade dress and trade secrets ("Intellectual Property Rights"). Seller will defend at its expense and will pay the cost of any settlement or damages awarded in an action brought against Buyer based on an allegation that a Product sold pursuant to this Agreement infringes the Intellectual Property Rights of a third party. Seller's obligation to defend and indemnify Buyer is contingent on Buyer notifying Seller within ten (10) days after Buyer becomes aware of such allegations of infringement, and Seller having sole control over the defense of any allegations or actions including all negotiations for settlement or compromise. If a Product is subject to a claim that it infringes the Intellectual Property Rights of a third party, Seller may, at its sole expense and option, procure for Buyer the right to continue using the Product, replace or modify the Product so as to make it noninfringing, or offer to accept return of the Product and return the purchase price less a reasonable allowance for depreciation. Notwithstanding the foregoing, Seller shall have no liability for claims of infringement based on information provided by Buyer, or directed to Products delivered hereunder for which the designs are specified in whole or part by Buyer, or infringements resulting from the modification, combination or use in a system of any Product sold hereunder. The foregoing provisions of this Section shall constitute Seller's sole and exclusive liability and Buyer's sole and exclusive remedy for infringement of Intellectual Property Rights.

19. Entire Agreement. This agreement contains the entire agreement between the Buyer and Seller and constitutes the final, complete and exclusive expression of the terms of sale. All prior or contemporaneous written or oral agreements or negotiations with respect to the subject matter are herein merged.

20. Compliance with Law, U. K. Bribery Act and U.S. Foreign Corrupt Practices Act. Buyer agrees to comply with all applicable laws and regulations, including both those of the United Kingdom and the United States of America, and of the country or countries of the Territory in which the Buyer may operate, including without limitation the U. K. Bribery Act, the U.S. Foreign Corrupt Practices Act ("FCPA") and the U.S. Anti-Kickback Act (the "Anti-Kickback Act"), and agrees to indemnify and hold harmless Seller from the consequences of any violation of such provisions by Buyer, its employees or agents. Buyer acknowledges that they are familiar with the provisions of the U. K. Bribery Act, the FCPA and the Anti-Kickback Act, and certifies that Buyer will adhere to the requirements thereof. In particular, Buyer represents and agrees that Buyer shall not make any payment or give anything of value, directly or indirectly to any governmental official, any foreign political party or official thereof, any candidate for foreign political office, or any commercial entity or person, for the purpose of influencing such person to purchase products or otherwise benefit the business of Seller.

02/12

Parker Hannifin Corporation
Pneumatic Division
8676 E. M89
P.O. Box 901
Richland, MI 49083 USA
Tel: 269 629 5000
Fax: 269 629 5385

Applications Engineering
Phone: 877 321 4PDN Option #2
E-mail: pdnapps@parker.com
Customer Support
Phone: 877 321 4PDN Option #1
E-mail: pdncustsvc@parker.com
Web site: www.parker.com/watts

