

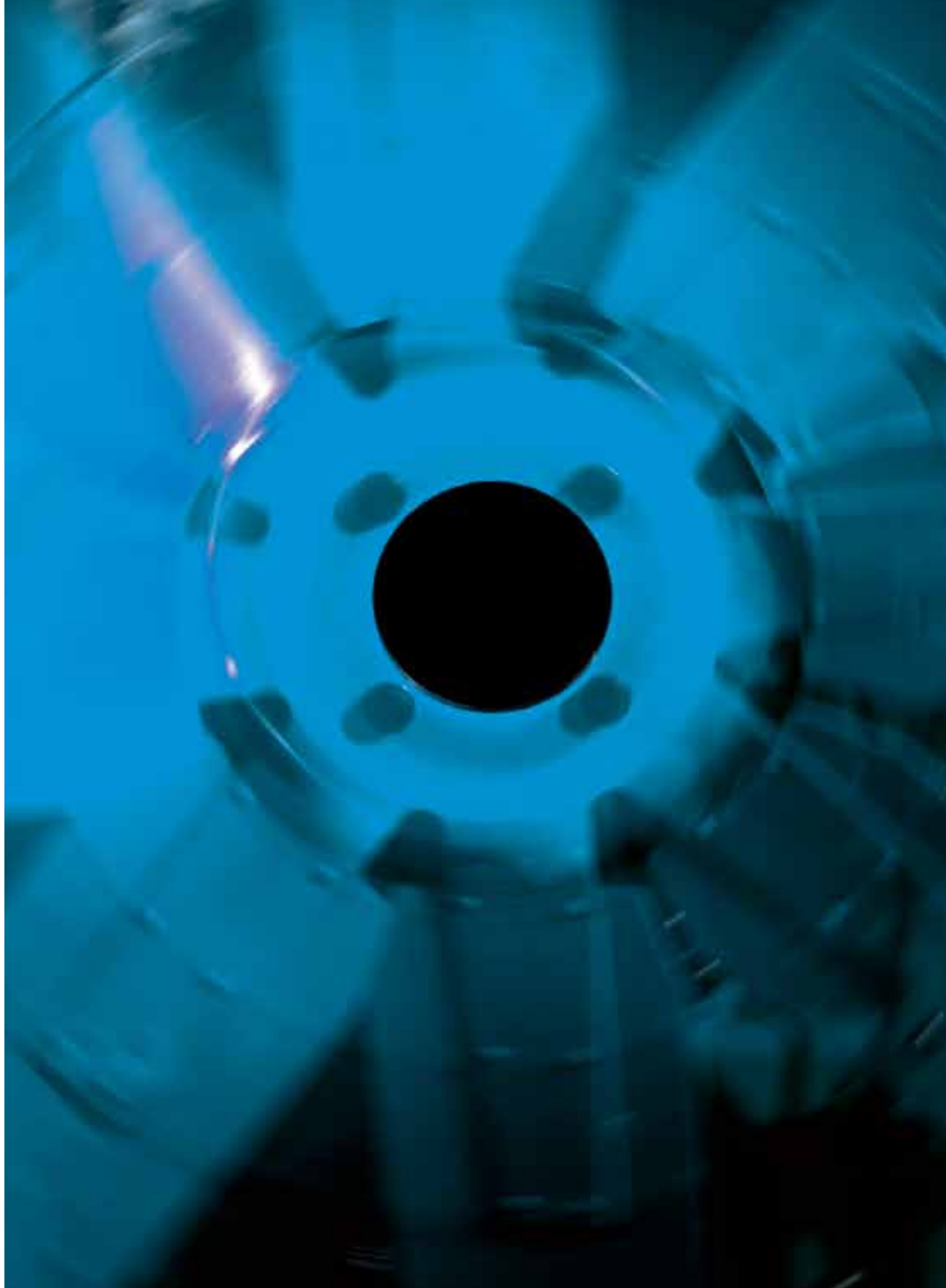

aerospace
climate control
electromechanical
filtration
fluid & gas handling
hydraulics
pneumatics
process control
sealing & shielding



Hydraulic Fan Drive Solutions

For the Wheel Loader Market



ENGINEERING YOUR SUCCESS.



Table of Contents

Introduction: Performance and Fuel Saving Optimization	1
Advantages of Parker Hydraulic Fan Drive Systems	2
Solutions and Circuits	3
Designing the System	10
Component Specifications	11
Summary: Maximizing Value with Parker	20

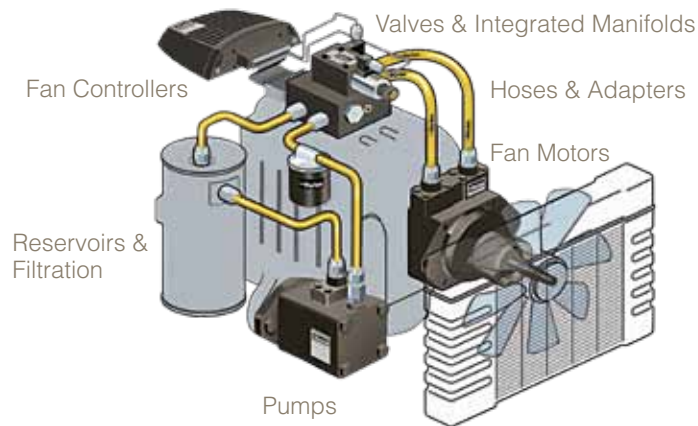

WARNING - USER RESPONSIBILITY

FAILURE OR IMPROPER SELECTION OR IMPROPER USE OF THE PRODUCTS DESCRIBED HEREIN OR RELATED ITEMS CAN CAUSE DEATH, PERSONAL INJURY AND PROPERTY DAMAGE.

This document and other information from Parker-Hannifin Corporation, its subsidiaries and authorized distributors provide product or system options for further investigation by users having technical expertise.

The user, through its own analysis and testing, is solely responsible for making the final selection of the system and components and assuring that all performance, endurance, maintenance, safety and warning requirements of the application are met. The user must analyze all aspects of the application, follow applicable industry standards, and follow the information concerning the product in the current product catalog and in any other materials provided from Parker or its subsidiaries or authorized distributors.

To the extent that Parker or its subsidiaries or authorized distributors provide component or system options based upon data or specifications provided by the user, the user is responsible for determining that such data and specifications are suitable and sufficient for all applications and reasonably foreseeable uses of the components or systems.

OFFER OF SALE

The items described in this document are hereby offered for sale by Parker-Hannifin Corporation, its subsidiaries or its authorized distributor. This offer and its acceptance are governed by the provisions stated in the detailed "Offer of Sale."



Performance & Fuel Saving Solutions for Wheel Loader Cooling Systems

Increasing government emission regulations on wheel loaders & construction equipment require engine solutions with significantly higher cooling requirements and

more precise temperature control. Engine cooling systems need to be highly efficient to conserve power and fuel for the vehicle. In addition, these systems need to be

quiet and reliable. An integral part of the engine cooling system is the fan drive system, and hydraulic fan drive systems are an excellent solution to meet these demands.

An optimized cooling system requires skilled integration of multiple technologies

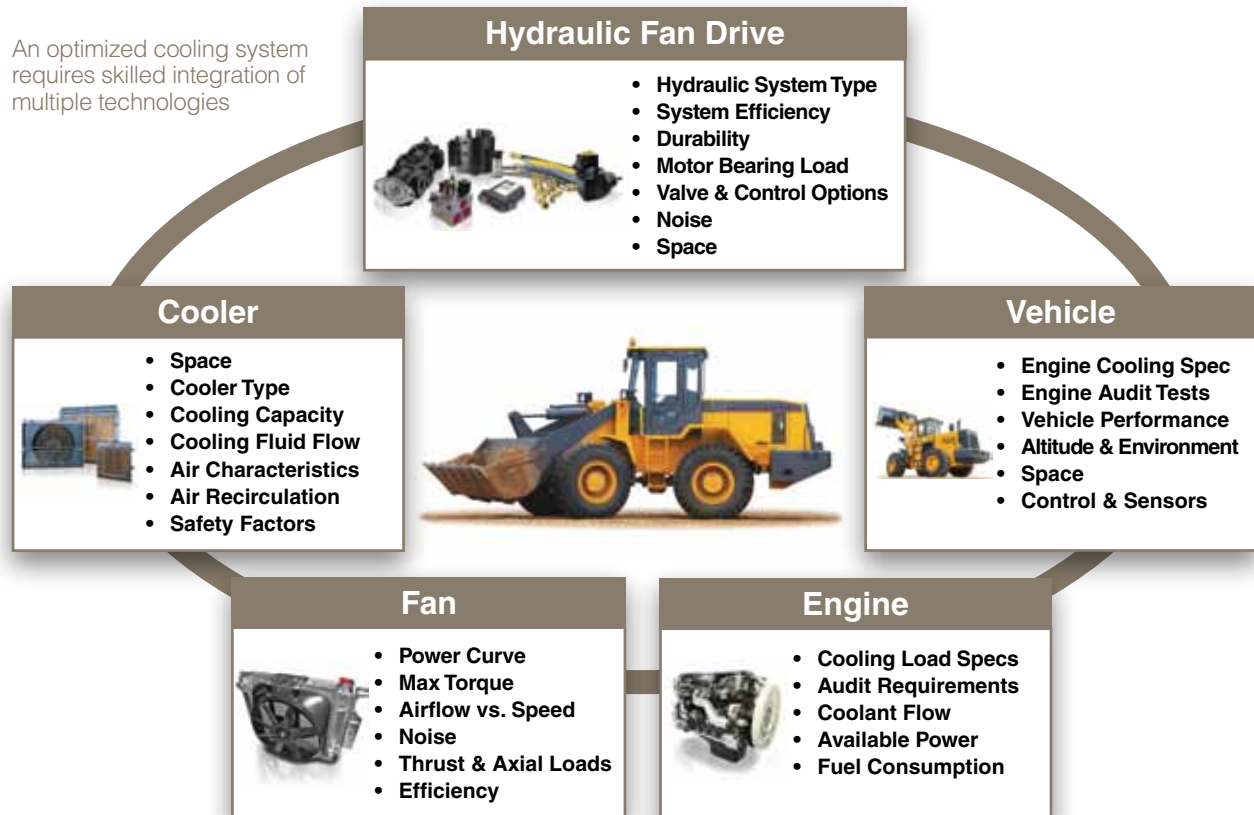

Optimizing the System:

Parker has extensive experience in designing fan drive systems for the wheel loader & construction market, but the fan drive is only one piece of a fully optimized cooling system. Designing an engine cooling system is complex, and can require time consuming coordination with multiple technologies and suppliers. Design decisions for one component such as the cooler impact others such as the fan drive, and each supplier may make assumptions with additional factors for safety. Parker will lead or support a collaborative system design process to speed your development time while maximizing total system performance and value.

Global Support: System Engineering Centers

Parker's global engineering team, is supported from initial design systems centers and market all the way through to your end specialists ensure your Parker system customer.



Advantages of Parker's Hydraulic Fan Drive Systems

Parker hydraulic fan drive systems are efficient throughout the engine and vehicle's operating range. Traditional on/off clutch solutions operate only at maximum speed and can suddenly drain power to the vehicle. Viscous or wet clutch solutions offer

variable fan speed but have limited efficiency at intermediate speed which occur during the majority of a Wheel Loader's work cycle. A unique advantage hydraulic fan drives offer over clutch systems is the ability to provide maximum fan speed at any

Engine RPM. Parker's hydraulic fan drives offer maximum power density and efficiency can be optimized when the control logic is integrated into the complete vehicle controller.

Reduced Power Consumption, Increased Control:

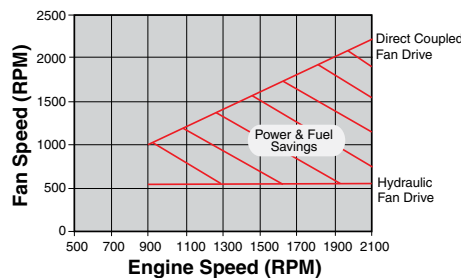
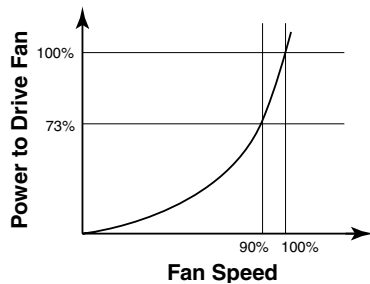

Traditional direct-drive engine mounted fan systems consume excess power because the fan speed is dependent on the engine speed. As the engine speed changes, the fan is often driven faster than what is required to cool the engine. This inefficiency is very significant especially at high fan speeds because the power required to increase fan speed increases exponentially by the power of 3. In addition, direct-drive systems have difficulty achieving high cooling levels at the intermediate speeds the wheel loader often runs during its work cycle.

A hydraulic fan drive system allows variable fan speed independent of the engine speed. It provides only the cooling that is required throughout the operating range of the vehicle including such requirements as the maximum engine rated torque point where high cooling may be required at lower than maximum engine speed. The full cooling control of hydraulic fan drives enables ramping

of the fan speed command to avoid shock and to idle the fan during engine startup to preserve power. Hydraulic fan drive systems enable full fan control yielding significant power and fuel savings.

Flexible Installation:

In most mobile machines like wheel loaders, the location of the cooler in front of the engine is

not the best solution, especially when considering the air flow or the construction of the machine. In addition, vehicle designers are challenged to meet styling and serviceability requirements in less space with reduced noise. Parker's hydraulic fan drive systems solve these challenges by allowing the drive motor, shroud and radiator to be strategically located anywhere on a vehicle.

Low Noise:

Emitted noise from a wheel loader is limited by government regulations. This puts high demands on design and construction of the machine. Parker's quiet fan drive systems help machine manufacturers meet these very stringent demands.

Maximum Efficiency to Conserve Power and Fuel:

Direct-driven fan drives require large tip clearance to allow for independent movement between the engine and radiator assembly. This large tip clearance reduces the efficiency of the cooling air flow across the radiator by as much as 10-15% compared to a hydraulic fan drive system where the fan motor, fan and radiator are attached to each other.

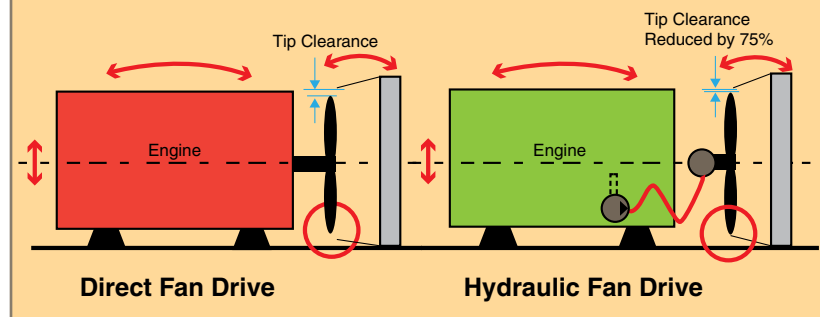

A hydraulic fan drive reduces tip clearance and improves airflow by 10-15%.



Durability & Reliability:

Typically the fan on a wheel loader is subject to significant g-forces especially when traveling over rough terrain. Parker's heavy duty motor bearings are specified to withstand the high loads seen at the motor shaft due to these forces. In

addition, dust and contamination protection on the motor shaft seal is essential. Parker's well protected shaft seals are designed to maximize the life of the motor under these tough environmental conditions. Parker's hydraulic systems have

proven reliability in the most rugged applications. They are simple to service and provide exceptional life when properly maintained. Utilizing Parker's hose and fittings ensures efficient installation and leak free performance.

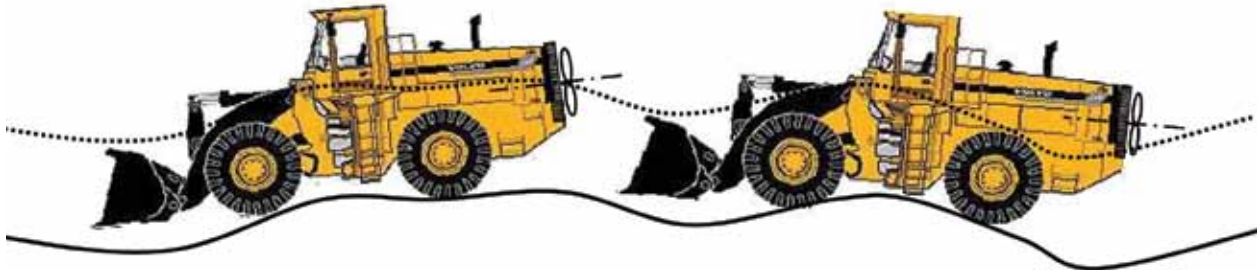

On Wheel Loaders, the fan motor is exposed to high axial and radial g-forces

Solutions for the Wheel Loader Market



Parker is in the unique position of having three fan drive motor and pump technologies which can be supplied for the fan drive function on a wheel loader. Each of these technologies; Gear, Vane and Piston, offer distinct advantages in terms of initial purchase cost, life time cost, efficiency and noise.

In this section, three example systems are summarized and categorized as "Basic Efficient System, Additional Performance and Optimized Performance". The "Basic Efficient" system can be considered lower installed cost while still retaining the main

hydraulic fan drive benefits outlined earlier in this guide. The "Optimized Performance" system will have the highest installed cost, but offers very distinct advantages when considering the environment, efficiency and life time cost.

Parker's representatives can help you select the correct system to meet the needs of your vehicle and to maximize their benefits in your cooling system. In addition to the drive motor and pump, they can help you select the right Parker control valves, electronic controller, filters and hose assemblies.

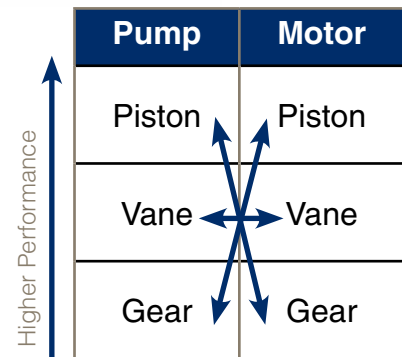

Parker offers the widest selection of hydraulic fan drive solutions. Pump and motor technologies are selected to optimize performance and value.



“Basic Efficient ” System: Fixed Pump, Variable Speed Fan + Implement Hydraulics

This system utilizes gear pump and motor technology and combines a variable speed fan drive and reversing function into three simple integrated components to create a cost effective, efficient

fan drive system. If the reverse function is not required, the proportional relief valve and check valves can be integrated into the gear motor reducing the number of components to only

two. For the best efficiency and durability throughout the fan drive temperature range, upgrading to Parker’s 600 series pumps and motors provides unmatched performance.

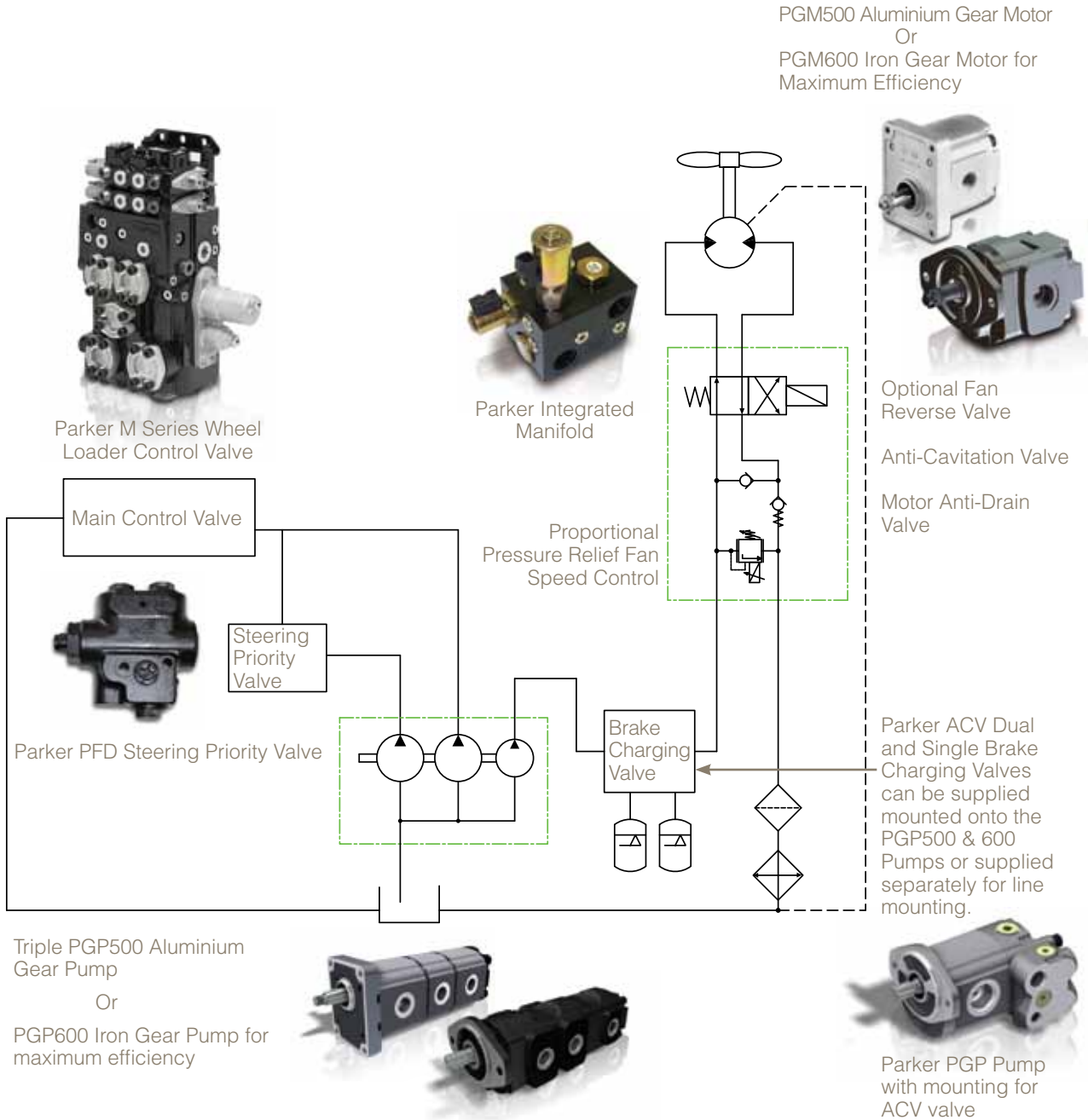



“Basic” - Efficient System Summary:

In this system a triple pump is shown, one pump to give priority flow to the steering and when this is not required it joins the second pump for boom bucket and auxiliary functions. The third pump is used to give priority to the brake charging and then onto the fan drive. This typical system gives the best optimization of the flow and power distribution when using

fixed displacement pumps. The combination of pumps is very much dependent on the machine size and space envelope. Typically on very small wheel loaders only one pump is used for steering and implements, and a separate pump is used for the brake charge and fan drive systems. On larger wheel loaders greater than 100 HP, typically two pumps are used; one

to give priority flow to steering and then one to join the other pump for the implements as shown in this circuit. A third pump is then used for the brake charging and fan drive. These pumps could be mounted as an integrated triple combination or separately if the space envelope is restricted.

Performance and Value:

- Cost effective PGP500 variable fan speed solution
- Efficient and simple system - more power and fuel savings to the vehicle
- Fan reversing to clear radiator and maximize radiator efficiency
- Design and Supply Chain savings:
 - The complete hydraulic fan drive system integrated into only 3 components
 - Reduced design, installation labor, hose/fitting and procurement costs
- Upgrading to the 600 series pumps/motors adds market leading durability and efficiency even at high fluid temperatures
- Parker’s strong application expertise and support from design through prototype stages

Parker’s 600 Series Cast Iron Pumps & Motors:

- Patented 2-Piece interlocking body
- Highest efficiency at extreme temperatures
- Compact size and weight
- High pressures



“Additional Performance”: Basic System + Integrated Vane Motor with Reversing Valve

This system builds on the “Basic Efficient System” by using Parker’s robust vane motor technology with the reversing valve, proportional valve and check valves efficiently

integrated into the motor. Parker’s 600 series pump is utilized to provide superior efficiency and performance even at high temperatures.

Parker’s quiet vane pumps may also be used to achieve the lowest noise levels and allow additional porting/installation options.

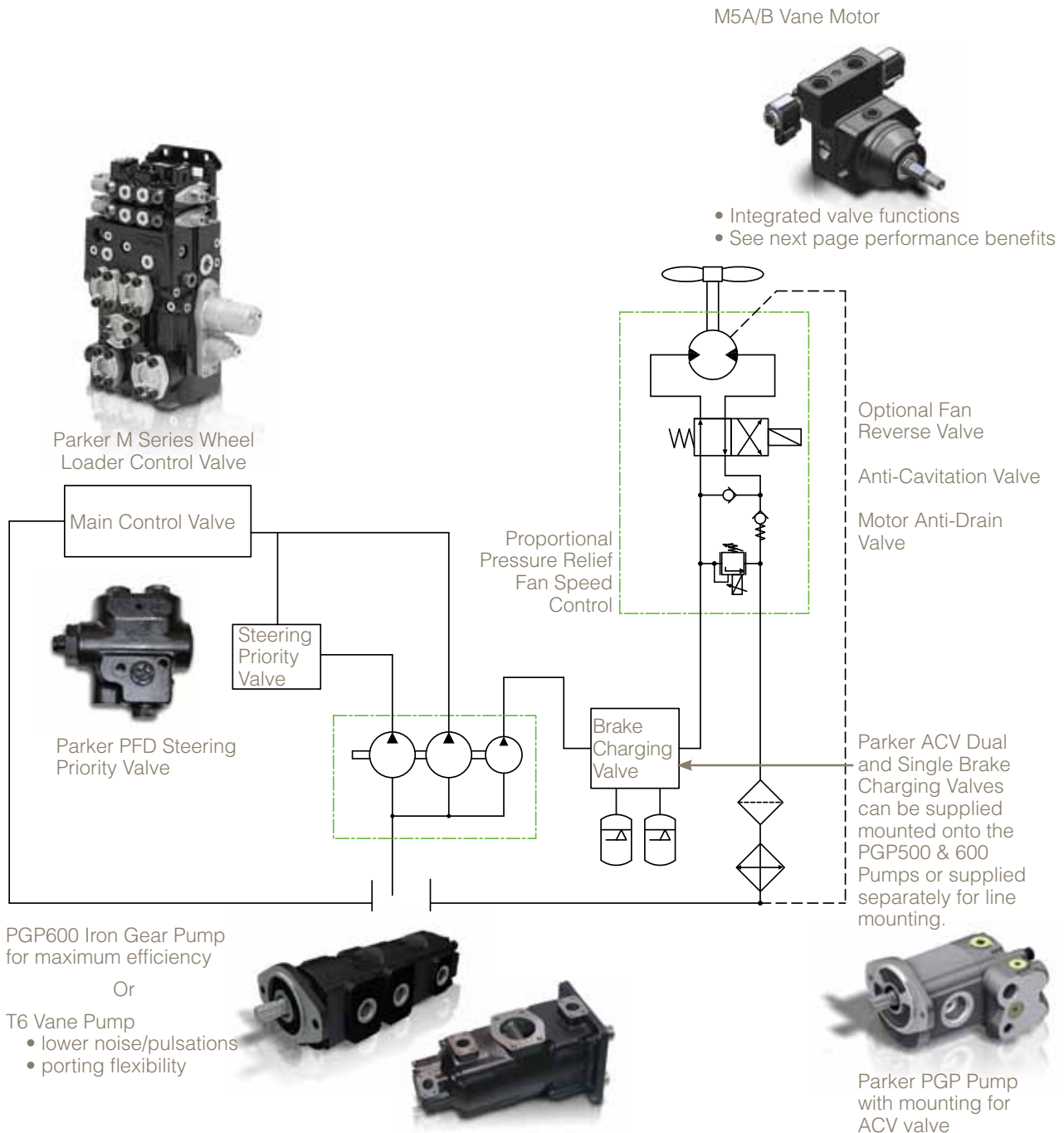



“Additional Performance” System Summary:

This system operates the same as the “Basic Efficient System,” but the control manifold is replaced with a simple fan drive circuit utilizing a single pump and a vane fan motor which integrates all necessary valves including the reversing valve, into the motor casting. The reversing valve switches direction of the motor by energizing the solenoid. Appropriate set point logic is incorporated into the fan drive

controller to ramp down the fan speed before reversing and then control the maximum time the fan is in reverse. Control logic to manage these functions is built into a wheel loader controller such as Parker’s VMM 3120 or 0604 Controllers. To achieve lower noise level and additional port location flexibility, vane pumps may be applied instead of the PGP600 gear pump.



See catalog HY29-0002 for further information on Parker Vane Pumps

Performance and Value:

- Cost effective variable fan speed solution
- Maximum efficiency and fuel savings for a fixed pump system
- Fan reversing to clear radiator and maximize radiator efficiency
- Design and Supply Chain savings:
 - The complete wheel loader fan drive system integrated into two components
 - Reduced design, installation labor, hose/fitting, and procurement costs
- Parker’s strong application expertise and support from design through prototype stages
- Vane motor optimized for fan drive function:
 - Extremely low noise
 - Integrated proportional relief, reversing & check valves, speed sensor
 - Reliable, heavy duty long life bearings to support fan loads
 - Excellent mechanical and volumetric efficiency throughout pressure & temperature operating range
 - Unique protected internal shaft seal, barrier to blown in debris

“Optimized Performance”: Variable Flow Piston Pump + Integrated Vane Motor

This solution is typically used on larger machines and is Parker’s most efficient hydraulic fan drive solution for all sizes of wheel loader. It consists of a variable piston pump driving the vane motor which has the same exceptional benefits previously summarized in the “Additional Performance Solution”. A variable piston solution is very

similar to the basic system except that it produces the exact flow needed to control all the functions, including the desired fan speed, with no inefficient bypass flow diverted to tank. A fan reversing valve cleans the radiator and assures optimal radiator efficiency. The reversing, anti-cavitation check and anti-drain checks are

efficiently integrated into the vane motor. A fan speed sensor can also be installed in the vane motor for optimal fan speed monitoring or closed loop control. For example, the speed sensor can be used to make sure the fan speed is at its lowest speed before reversing.

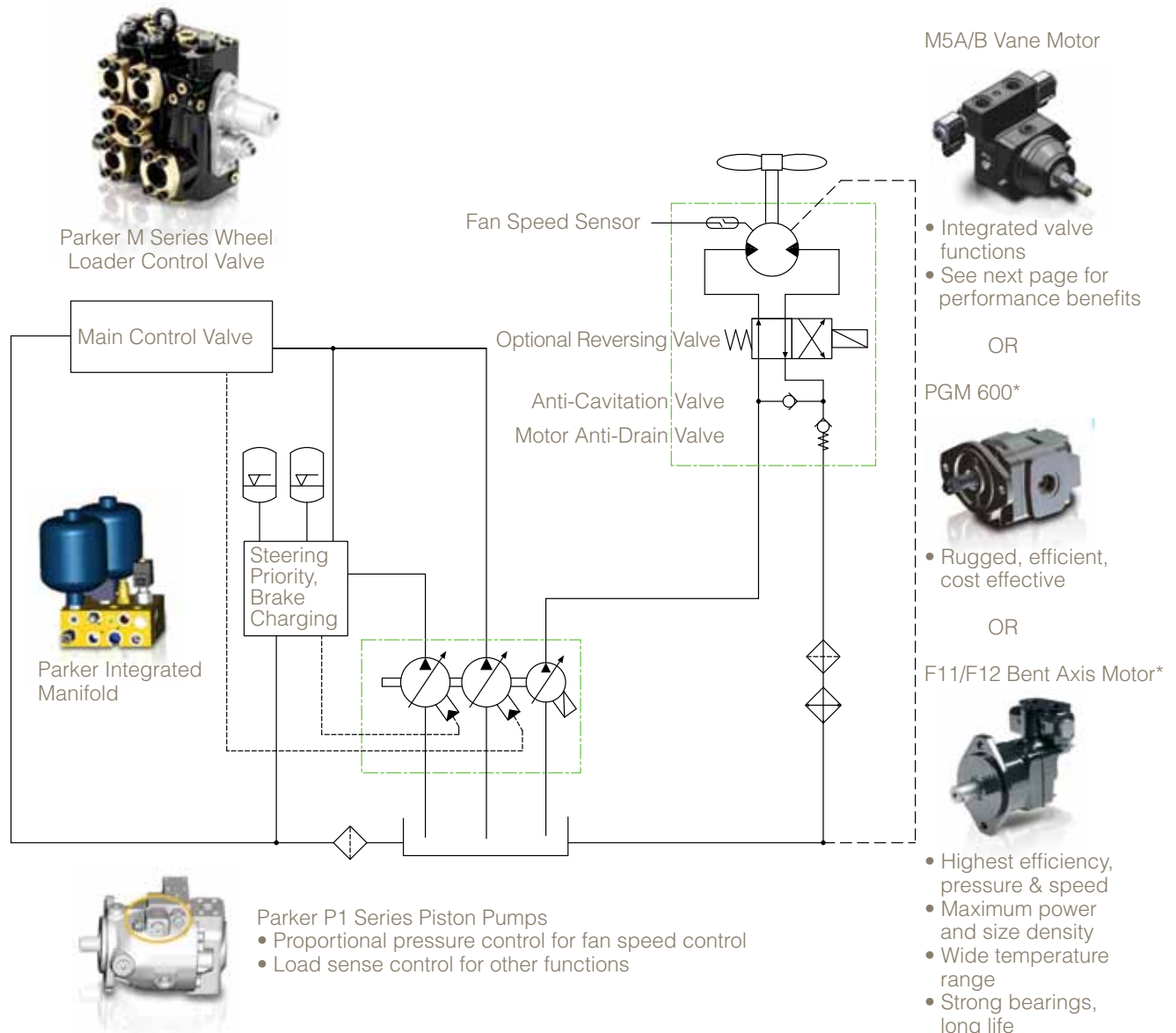

*Reversing valve requires separate manifold



“Optimized Performance” System Summary:

The system operates by commanding a Pulse Width Modulated signal to the proportional pressure compensator on the piston pump. When commanded to increase pressure, the piston pump increases its displacement to increase flow. The fan speed increases as the pressure rises. When the commanded pressure is reached, the pump reduces and modulates its flow to maintain the commanded pressure and fan speed. The default pressure at zero command signal is

maximum pressure to assure fail-safe cooling protection.

This solution also continuously filters the system to control contamination levels because the fan drive pump is always producing flow.

Total efficiencies of Parker’s P1 piston pump range from 85%-91% depending on pump size and operating conditions to assure maximum power stays with the vehicle. A small amount of flow is diverted to control the pump

compensator and should be accounted for in sizing calculations. For reversing, appropriate logic is incorporated into the fan drive controller to ramp down the fan speed before reversing. Alternate piston pump controls are available such as Parker’s RDEC electronic displacement control which precisely controls pump flow instead of pressure to provide minimal control leakage and excellent system stability.

Performance and Value:

- Maximum fan drive system efficiency and fuel savings
- Fan reversing to clear radiator and maximize radiator efficiency
- Design and Supply Chain savings:
 - The complete hydraulic fan drive integrated together into two components
 - Reduced design, installation labor, hose/fitting and procurement costs
- Vane motor optimized for fan drive function:
 - Extremely low noise
 - Integrated proportional relief, reversing & check valves, speed sensor
 - Reliable, heavy duty long life bearings to support fan loads
 - Excellent mechanical and volumetric efficiency throughout pressure & temperature operating range
 - Unique protected internal shaft seal, a barrier to blown in debris
 - Optional speed sensor port integral to the motor for monitoring and control
- Parker’s P1 piston pump technology:
 - Compact design
 - Lowest noise in the industry due to ripple chamber
 - High overall efficiency throughout temperature range
 - Proven durability in harsh environments
- Parker’s strong application expertise and support from design through prototype stages



Designing the System:

Hydraulic Fan Drive System Information Checklist

The following checklist is helpful to design and optimize a hydraulic fan drive system:

✓ Fan:

- Maximum fan speed required
- Fan power curve or rated power at its rated speed
- Thrust or axial loads
- Weight and center of gravity

✓ Engine:

- Speed at peak torque and peak power
- Lowest engine speed requiring maximum fan speed
- Minimum and maximum engine speed

✓ Pump Drive:

- Speed ratio of pump drive to engine
- Mounting and clearance

✓ Maximum Desired Hydraulic Pressure?

✓ Hydraulic Component Details:

- Pump and motor: flange type, mounting clearance, shaft type, rotation
- Other Information: port type, size & space restrictions, voltage

✓ Fluid Type and Operating Temperature Range

✓ Desired Features

- Reversing
- Speed sensor and/or type of speed control logic

✓ Duty Cycle of the Fan and Vehicle

- Acceleration forces at the fan (G-forces)
- Expected fan speeds at different operating points

Development Process:

Parker's experienced engine cooling and fan drive application team supports you through every step of the system development process. Often, an important initial step is to benchmark and instrument the current

system's performance to define the project scope and goals. Customers often choose to deliver a Wheel Loader to Parker's Systems Engineering Center for instrumentation and development, or our engineers

can assist at your own site. Whether hydraulic systems are relatively new to your vehicle, or already common, Parker's support team is available to assure success from Baseline Development to Production and Field Support.



Parker's Global Applications Team supports you from system development to the field

Fan Drive Component Specifications

Pump and Motor Summary for Wheel loader Fan Drive Systems:

Parker Fan Drive Pumps

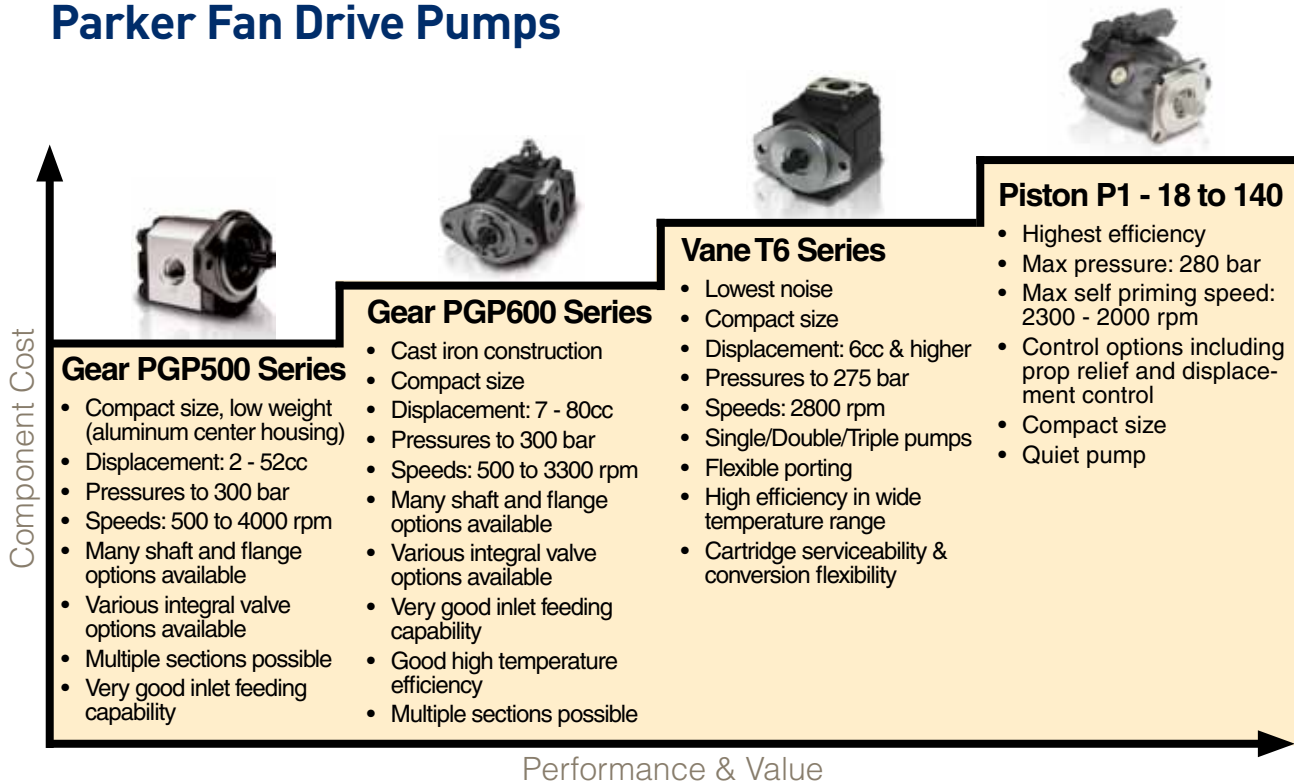

Parker Fan Drive Motors

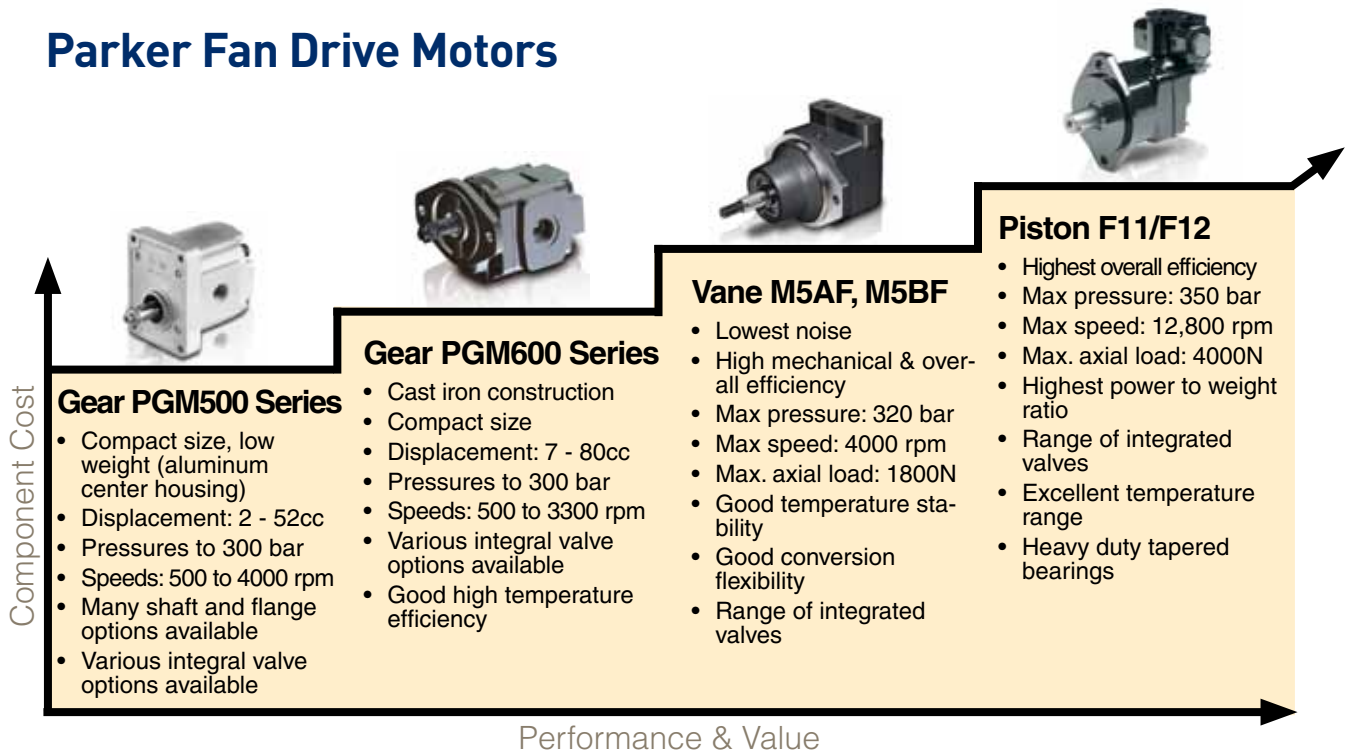

Gear Pump and Motor Specifications

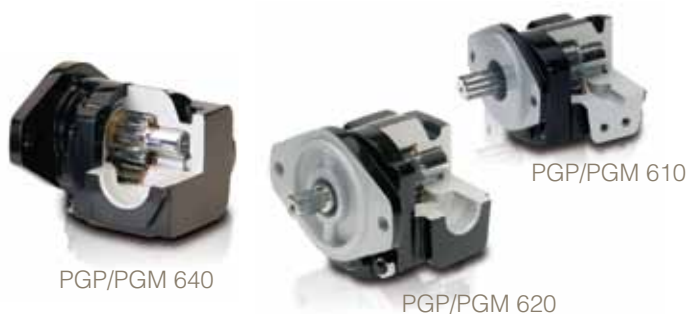

PGP/PGM 610 Specifications - Standard Displacements - Single Unit

Description	Code	0070	0100	0140	0160	0180	0210	0230	0260	0280	0320
Displacements	cm ³ /rev	7	10	14	16	18	21	23	26	28	32
	in ³ /rev	0.43	0.61	0.85	0.98	1.10	1.28	1.40	1.59	1.71	1.95
Continuous Pressure	bar	275	275	275	275	265	245	235	215	200	175
	psi	3989	3989	3989	3989	3843	3553	3408	3118	2901	2538
Intermittent Pressure	bar	300	300	300	300	290	270	260	240	220	175
	psi	4351	4351	4351	4351	4206	3916	3771	3480	3190	2538

Max. operating speed 3300 rpm

PGP/PGM 620 Specifications - Standard Displacements - Single Unit

Description	Code	0090	0230	0260	0290	0330	0370	0410	0440	0500
Displacements	cm ³ /rev	19	23	26	29	33	37	41	44	50
	in ³ /rev	1.16	1.40	1.59	1.77	2.01	2.26	2.50	2.68	3.05
Continuous Pressure	bar	275	275	275	275	275	250	220	210	210
	psi	3989	3989	3989	3989	3989	3626	3191	3046	3046
Intermittent Pressure	bar	300	300	300	300	300	275	245	230	210
	psi	4351	4351	4351	4351	4351	3989	3553	3336	3046

Max. operating speed 3000 rpm

PGP/PGM 640 Specifications - Standard Displacements - Single Unit

Description	Code	0300	0350	0450	0550	0650	0750	0800
Displacements	cm ³ /rev	30	35	45	55	65	75	80
	in ³ /rev	1.83	2.14	2.75	3.36	3.97	4.58	4.88
Continuous Pressure	bar	275	275	275	275	275	235	215
	psi	3989	3989	3989	3989	3989	3408	3118
Intermittent Pressure	bar	300	300	300	300	300	260	240
	psi	4351	4351	4351	4351	4351	3771	3489

Max. operating speed 3000 rpm

See Parker catalog HY09-0600 for further details on 600 Series products

Gear Pump and Motor Specifications



PGP 500

PGP/PGM 505 Specifications

Description	Code	0020	0030	0040	0050	0060	0070	0080	0090	0100	0110	0120
Displacements	cm ³ /rev	2	3	4	5	6	7	8	9	10	11	12
	in ³ /rev	0.12	0.18	0.24	0.31	0.37	0.43	0.49	0.55	0.61	0.67	0.73
Continuous Pressure	bar	275	275	275	275	275	275	275	250	250	250	220
	psi	3988	3988	3988	3988	3988	3988	3988	3625	3625	3625	3190
Intermittent Pressure	bar	300	300	300	300	300	300	300	275	275	275	220
	psi	4350	4350	4350	4350	4350	4350	4350	3988	3988	3988	3190
Max. Speed @ 0 Inlet & Max. Outlet Pressure	rpm	4000	4000	4000	4000	3600	3300	3000	2900	2800	2400	2400

PGP/PGM 511 Specifications

Description	Code	0060	0070	0080	0100	0110	0140	0160	0180	0190	0210	0230	0270	0280	0310
Displacements	cm ³ /rev	6	7	8	10	11	14	16	18	19	21	23	27	28	31
	in ³ /rev	0.37	0.43	0.49	0.61	0.67	0.85	0.98	1.10	1.16	1.28	1.40	1.65	1.71	1.89
Continuous Pressure	bar	250	250	250	250	250	250	250	250	250	235	225	190	185	165
	psi	3625	3625	3625	3625	3625	3625	3625	3625	3625	3410	3265	2755	2685	2395
Intermittent Pressure	bar	275	275	275	275	275	275	275	260	260	240	235	200	190	170
	psi	3988	3988	3988	3988	3988	3988	3988	3770	3770	3480	3408	2900	2755	2465
Max. Speed @ 0 Inlet & Max. Outlet Pressure	rpm	4000	4000	4000	3600	3600	3300	3000	3000	3000	2800	2800	2400	2300	2300

See Parker Catalog HY09-0500 for further detail on 500 Series products

Gear Pump and Motor Options

Shaft Seals for Fan Motors:

It is recommended that an excluder shaft seal be included on fan motors to assure shaft seal protection from contamination. Internal shaft seals are specified according to the pressure on the motor outlet and /or drain line. Contact your Parker representative for further information on specifying the correct shaft seals for the system.

Valve Options for Motors:

The following integral valve options are available installed with the motor:

- Proportional Pressure Relief Valve – specify coil voltage, Normally Closed (typical) or Open
- Mechanical Pressure Relief Valve – specify relief valve setting
- Anti-Cavitation Check Valve

Outboard Bearing for Fan Motors:

For large fans producing high axial and/or radial loads on the motor shaft, an outboard bearing may need to be specified.

If envelope or installation constraints exist, the 300 Series Cast Iron pumps and motors are available. See Parker Catalog HY-09-300.

Contact your Parker representative for further information on specifying these options for your system.



Vane Motor Specifications

M5A* Specifications

Description	Code	006	010	012	016	019	025
Displacements	cm ³ /rev	6.3	10.0	12.5	16.0	18.0	25.0
Max. Continuous Pressure	bar	300	300	300	300	300	280
Max. Operating Speed	rpm	4000	4000	4000	4000	4000	2500
Max. Intermittent Pressure	bar	300	300	300	300	300	280

M5B* Specifications

Description	Code	012	018	028	036	045
Displacements	cm ³ /rev	12.0	18.0	28.0	36.0	45.0
Max. Continuous Pressure	bar	290	290	290	290	200
Max. Operating Speed	rpm	4000	4000	2500	2500	2500
Max. Intermittent Pressure	bar	320	320	320	320	280

See Parker catalog HY29-0018 for further details on the M5A* and M5B* products



M5BF

M5AS* Specifications

Description	Code	006	010	012	016	019	025
Displacements	cm ³ /rev	6.3	10.0	12.5	16.0	18.0	25.0
Max. Continuous Pressure	bar	280	280	280	280	280	280
Max. Operating Speed	rpm	5000	5000	3800	3800	3300	2800
Max. Intermittent Pressure	bar	300	300	300	300	300	280



M5AS

See Catalog HY29-0024 for further detail on the M5AS* Product.
Contact your Parker representative for further information on specifying these options for your system.

Vane Motor Optimized for Fan Drive Function:

- Integrated valves
 - Anti-Cavitation Check Valve
 - Anti-Starve Valve
 - Reversing Valve
- Extremely low noise
- Heavy duty, long life bearings to support fan loads
- Excellent mechanical and volumetric efficiency throughout pressure & temperature operating range
- Unique protected internal shaft seal, barrier to blown in debris

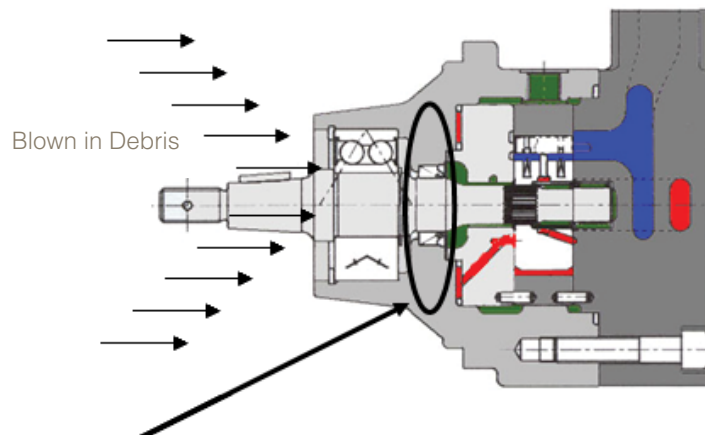

The vane motor's shaft seal behind the rugged sealed front bearing protects against shaft seal leaks from debris

Piston Pump and Motor Specifications



P1 Piston Pump

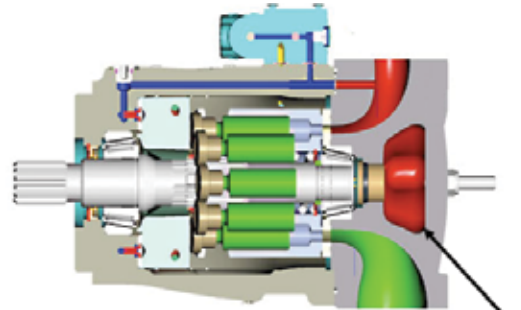

Parker's piston pump ripple chamber lowers pressure pulsations and noise

P1 Piston Pump Specifications

Description	Code	P1 018	P1 028	P1 045	P1 060
Max. Displacements	cm ³ /rev	18	28	45	60
	cu.in/rev	1.10	1.71	2.75	3.66
Outlet Pressure - Continuous	bar	280	280	280	280
	psi	4000	4000	4000	4000
Intermittent Pressure	bar	320	320	320	320
	psi	4500	4500	4500	4500
P1 (1.3 bar abs inlet)	rpm	3600	3400	3100	2800
P1 (1.0 bar abs inlet)	rpm	3300	3200	2800	2500
P1 (0.8 bar abs inlet)	rpm	2900	2900	2400	2200

Other displacements available: 75cc, 100cc and 140cc. See Catalog HY28-2665-01 for further detail on the P1 products.

Piston Pump Options

Proportional Pressure Control (Fan Drive) Compensator:

Controls fan speed by electrically commanding the pump pressure setting with PWM signal.

- Specify AJ (12VDC) or AK (24VDC compensator control)
- Specify mechanical maximum pressure setting if needed:
 - 3 = 140 bar; 4 = 210 bar; 5 = 250 bar; 6 = 280 bar; 7 = 350 bar
 - Example: AK6 = 24VDC with 280 bar mechanical max pressure relief

Load Sense Control:

Pump pressure setting can also be varied by supplying an external pressure signal to the pump load sense port. Specifying this 'LO' control allows:

- Load sense differential (standby) pressure adjustment 10-30 bar
- Maximum pressure adjustment 80-280 bar

Contact your Parker representative for further information on specifying these options for your system.

Electronic Displacement Control:

Parker's RDEC electronic displacement control precisely controls pump flow instead of pressure to control the fan speed, providing maximum efficiency through minimal control leakage and excellent system stability.

Bent Axis Piston Motors - F11/F12 Specifications



Bent Axis Specifications

Description	Code	F11					F12			
		-5	-6	-10	-12	-14	-19	-30	-40	
Max. Displacements	cm ³ /rev	4.9	6.0	9.8	12.5	14.3	19.0	30.0	40.0	
Operating Pressure	Max. Intermittent	bar	420	420	420	420	420	420	480	480
	Max. Continuous	bar	350	350	350	350	350	350	420	420
Motor Operating Speed	Max. Intermittent	rpm	14,000	11,200	11,200	10,300	9,900	8,900	7,300	6,700
	Max. Continuous	rpm	12,800	10,200	10,200	9,400	9,000	8,100	6,700	6,100
	Min. Continuous	rpm	50	50	50	50	50	50	50	50
Motor Input Flow	Max. Intermittent	l/min	69	67	110	129	142	169	219	268
	Max. Continuous	l/min	63	61	100	118	129	154	201	244
Main Circuit Temp.	Max.	°C	115	115	115	115	115	115	115	115
	Min.	°C	-40	-40	-40	-40	-40	-40	-40	-40
Theoretical Torque at 100 bar	Nm	7.8	9.5	15.6	19.8	22.7	30.2	47.6	63.5	
Mass Moment of Inertia	(x10 ⁻³) [kg m ²]	0.16	0.39	0.39	0.40	0.42	1.1	1.7	2.9	
Weight	kg	4.7	7.5	7.5	8.2	8.3	11	12	15.5	

See Catalog HY30-8249 for further detail on F11/F12 motors

Piston Motor Features:

- Compact motor range, extremely high power to weight ratio
- Heavy duty bearing
- High speed capability
- Low noise
- Integrated anti-cavitation check valve and pressure relief valve options
- High overall efficiency
- Integrated speed sensor

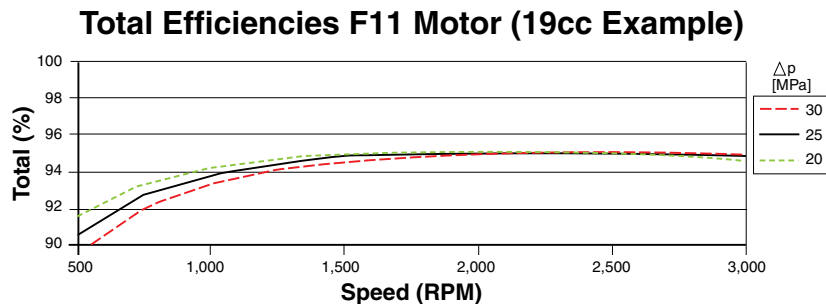

The unique spherical piston design of Parker's F11 bent axis motors enable extremely high overall efficiency (mechanical + volumetric) through a wide operating range



Valve Manifolds Specifications

Parker's Hydraulic Cartridge Systems Division has developed an extensive range of manifolds with integrated valves for common

fan drive and other functions such as brake charging on the wheel loader. In addition, modified or custom circuits can be

easily designed and delivered for prototyping quickly. Parker's integrated valve manifolds provide the following benefits:

- Flexible envelope and mounting
- Integrated valves reduce:
 - Hoses & fittings
 - Installation time
 - Supply chain logistics & costs
 - Leak points
- Field replaceable valves instead of the entire manifold
- Solid models quickly available
- Rapid prototyping capability



See Catalog HY15-3502 for further detail on valve manifolds

Hose and Fitting Specifications

With a long history of providing the most comprehensive selection of hoses, fittings, equipment and accessories, Parker's Hose Products Division can help you select the best product for your application. The tough conditions in the wheel loader environment demand the right product, including hoses that feature a variety of abrasion-resistant cover choices, flexibility, a wide range of fluid compatibility and more - characteristics that make Parker the hose supplier of choice for

customers that demand the most from their equipment.

Parker's adapters and hose fittings provide the industry's best corrosion protection, including improved plating to better resist the harsh environment on construction sites. Parker's proprietary XTR coating provides more than seven times SAE standard protection, giving you an outstanding advantage for protecting equipment in severe environments.



See Catalog 4400 for additional information on hose assemblies
See Catalog 4300 for further details on adapters



Filtration

Parker offers many filter types, configurations and filter solutions for Wheel loaders. Our engineers collaborate with the customer

at the earliest stage of design to develop filtration solutions which optimize installation, system performance and life cycle cost.

Some typical filter types and sizes are shown below and offer the following features:

- Multiple mounting configurations
- High capacity/high efficiency Microglass III media
- Visual and electrical indicators with several connector types
- Aftermarket protected (patented) filter elements

Contact your Parker representative for further information on specifying these options for your system

Suction & Return Filters



Medium & High Pressure Filters



Air Breather Filters



Integrated Reservoir Assemblies



Particle Detectors & Moisture Sensors



Electronic Controllers - Fan Drive & Full System

With overall vehicle electronic control systems becoming more common in the wheel loader market, the ability to integrate the fan drive control logic into the rest of the vehicle control system is important. Parker Hannifin offers a wide variety of CAN bus

based control platforms that can be integrated with the fan drive hydraulics. Integrating the fan drive into the overall vehicle control system can reduce the installation time and cost, reduce diagnostic time and increase fan drive efficiency by allowing all the

vehicle functions that could affect fan drive performance to be monitored. Integrating the fan drive into the vehicle control system still allows for full fan drive functionality, including:

- SAE J1939 CAN and analog inputs for fan speed control
- Fan reversing with ramps
- Automated and manual fan reversing
- Multiple fan locations with independent control
- Improved fault detection and diagnostics
- Software configuration of parameters



Full Wheel Loader System Controllers – Multiplexing Modules:
Contact your Parker representative for further information on specifying these options for your



Maximizing Value with Parker

Design:

Utilizing Parker's extensive cooling system design experience, we will collaborate with your preferred suppliers or use our supplier partners to speed system development while maximizing performance.

Supply Chain:

Parker offers logistics services all the way up to delivering the full fan drive or cooling system in a kit or subassembly.

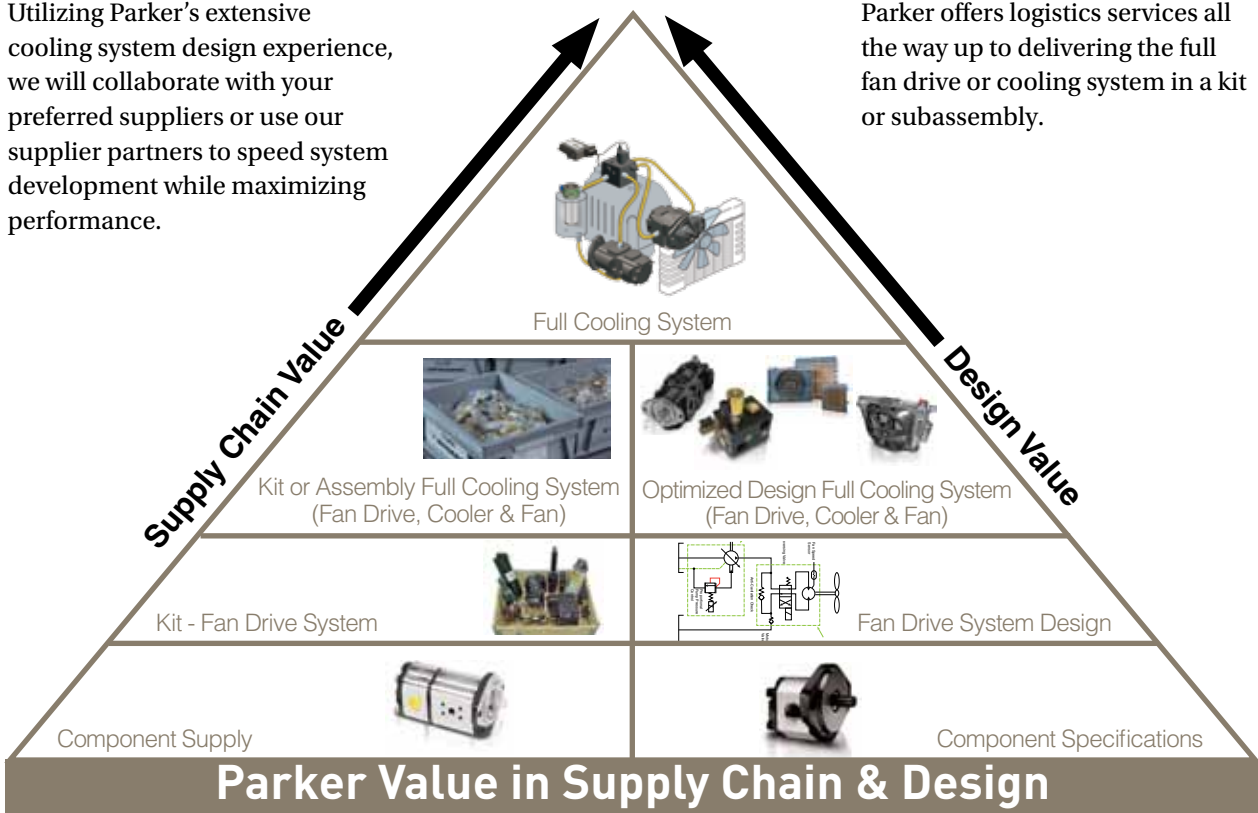

System Expertise:

- World Leader in the design, manufacture, and integration of hydraulic systems
- System Engineering Centers throughout the world to develop and validate an optimized cooling system

Widest Range of Solution Options:

- Full range of hydraulic components and controllers available for wheel loader Fan Drive Systems
- Enables selection of the best components to optimize the cooling system for your vehicle

Global Support:

- Global Manufacturing Operations, Sales Companies and Distributor Network
- Local Supply, Logistics and Assembly Capability
- Aftermarket, Field Support, Service and Repair



Sales Offices

Argentina, Buenos Aires
Tel: (54) 33 2744 4129

Australia, Castle Hill
Tel: (61) 2 9634 7777

Austria, Wiener Neustadt
Tel: (43) 2622 23501 0

Belgium, Nivelles
Tel: (32) 67 280 900

Brazil, Cachoeirinha RS
Tel: (55) 51 3470 9144

Canada, Milton, Ontario
Tel: (905) 693 3000

China, Beijing
Tel: (86) 10 6561 0520

China, Shanghai
Tel: (86) 21 5031 2525

Czech Republic and Slovakia,
Klecaný
Tel: (420) 284 083 111

Denmark, Ballerup
Tel: (45) 4356 0400

Finland, Vantaa
Tel: (358) 20 753 2500

France, Contamine-sur-Arve
Tel: (33) 4 50 25 80 25

Germany, Kaarst
Tel: (49) 2131 4016 0

Greece, Athens
Tel: (30) 210 933 6450

Hong Kong
Tel: (852) 2428 8008

Hungary, Budapest
Tel: (36) 1 220 4155

India, Mahape, Navi Mumbai
Tel: (91) 22 6513 7081

Ireland, County Dublin, Baldonnell
Tel: (353) 1 466 6370

Italy, Corsico, Milano
Tel: (39) 02 45 19 21

Japan, Tokyo
Tel: (81) 3 6408 3900

Korea, Seoul
Tel: (82) 2 559 0400

Malaysia, Subang Jaya
Tel: (60) 3 5638 1476

Mexico, Toluca, Edo. de Mexico
Tel: (52) 72 2275 4200

The Netherlands, Oldenzaal
Tel: (31) 541 585000

New Zealand, Mt. Wellington
Tel: (64) 9 574 1744

Norway, Ski
Tel: (47) 64 91 10 00

Poland, Warsaw
Tel: (48) 22 57 32400

Portugal, Leca da Palmeira
Tel: (351) 22 999 7360

Romania, Bucharest
Tel: (40) 21 252 1382

Russia, Moscow
Tel: (7) 495 645 2156

Singapore, Jurong Town
Tel: (65) 6 887 6300

Slovenia, Novo Mesto
Tel: (386) 7 337 6650

South Africa, Kempton Park
Tel: (27) 11 961 0700

Spain, Madrid
Tel: (34) 91 675 7300

Sweden, Spånga
Tel: (46) 8 597 95000

Taiwan, Taipei
Tel: (886) 2 2298 8987

Thailand, Bangkok
Tel: (662) 717 8140

Turkey, Istanbul
Tel: (90) 212 482 9106

Ukraine, Kiev
Tel: (380) 44 494 2731

United Arab Emirates, Abu Dhabi
Tel: (971) 2 678 8587

United Kingdom, Warwick
Tel: (44) 1926 317878

USA, Cleveland, OH
Tel: (800) 272 7537
(800-C-Parker)



Parker Hannifin Corporation
Hydraulics Group
6035 Parkland Blvd.
Cleveland, OH 44124
phone 216 896 3000
fax 216 896 4031
www.parker.com/hydraulicsgroup