



aerospace
climate control
electromechanical
filtration
fluid & gas handling
hydraulics
pneumatics
process control
sealing & shielding



Pneumatic Weld Control Products

Catalog PCD2005-3



ENGINEERING YOUR SUCCESS.

Waterblock Series WB Designed for Welding Applications

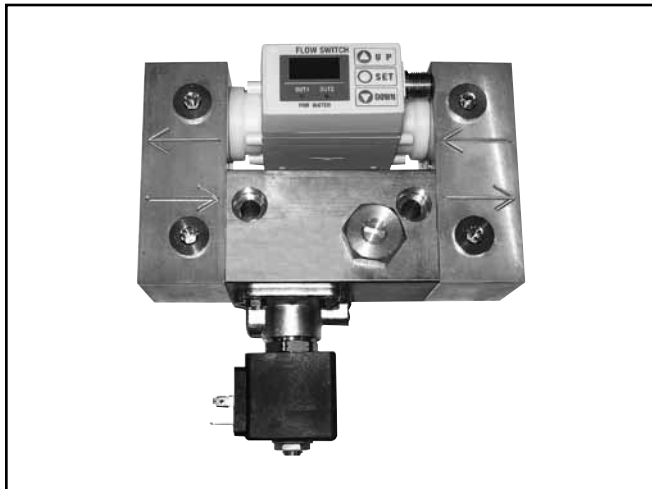

Waterblock is an integrated manifold made from brass that supplies and monitors water to the weld cell. Utilizing a highly sensitive Vortex Flow Sensor to detect leakage or improper supply to the cell, the Parker WBB will provide the essential protection for expensive welding equipment. The system includes both an integrated electronic shut-off along with an internal check valve to assure proper shutdown, should an event occur. System balance is maintained with the input flow restrictor, which allows repeatable setup. Welding control circuit is included into the package to allow cooling control from ONE location. Maintenance is simple due to the unique manifold design allowing removal of all major components without the need to remove the connections to the manifold. Assembled options are available on request.

Technical Data

Water Service Unit	
Supply Return Connection	3/4" BSPP / NPT
Robot Connections	3/4" BSPP / NPT
Pressure	6 bar (87 PSI)
Operation Temperature	-25°C to + 80°C
Voltage	20 to 30VDC
Check Valve	Return Path
Flow	40 L/min (10.6 G/min)
Performance	
Leak Detection	< 1s
Shut-off	< 100ms
Outputs	2 PNP or NPN
Flow Restrictor	5 –100% (Approx)
Materials	
Housing	Plastic, Brass
Fittings	Brass
Weight	Plastic: 1 kg (2.2lb), Brass: 3.5 kg (7.8lb)

Model Number Index

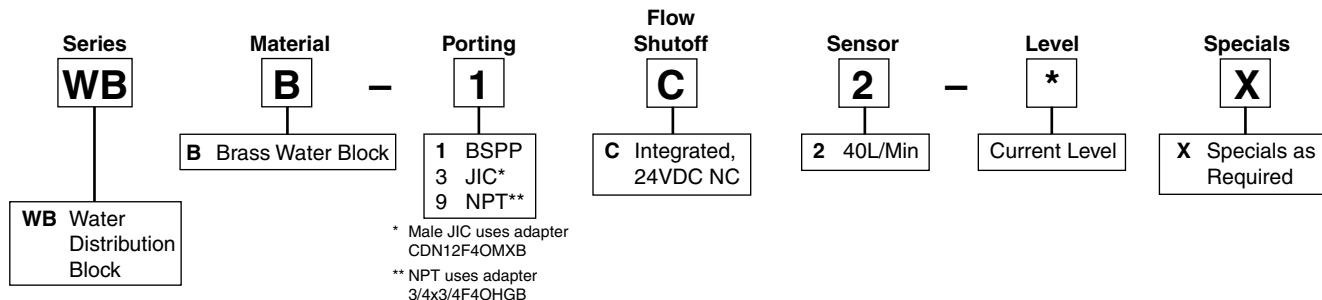

Note: Part number WBB1C2, supercedes part numbers WBB-1666-C1/C2, WBB112/4, 3554800. Refer to dimensions on page 18 for current model.

Spare Parts

CDN12F4OMXB	Water Fittings - Brass
3/4 x 3/4F4OHGB	Water Fittings - Brass
5554851	Check Valve
7321BAN00	Skinner Valve N/C
7321BAN01	Skinner Valve N/C with Manual override
481865C2	Coil

Fittings

CDN12F4OMXB
 Male Connector - BSPP
 Brass Body / Nitrile O-ring

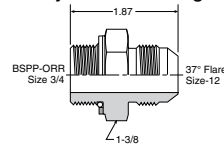

3/4x3/4F4OHGB
 Conversion Adapter
 Brass Body / Nitrile O-ring

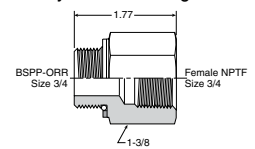

Schematic

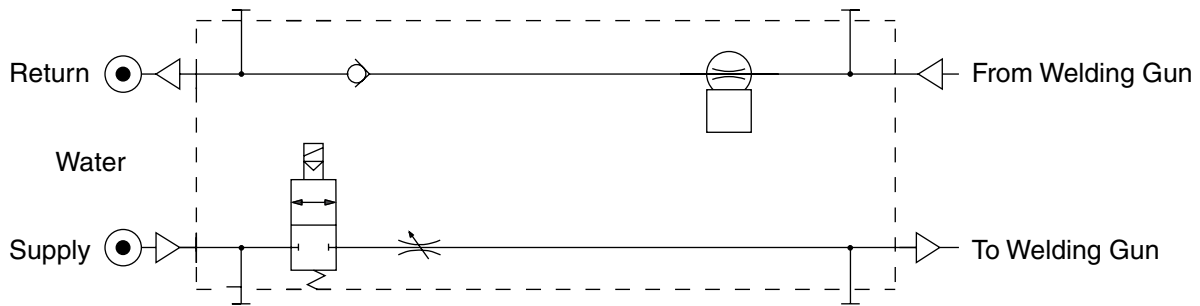

Dimensions

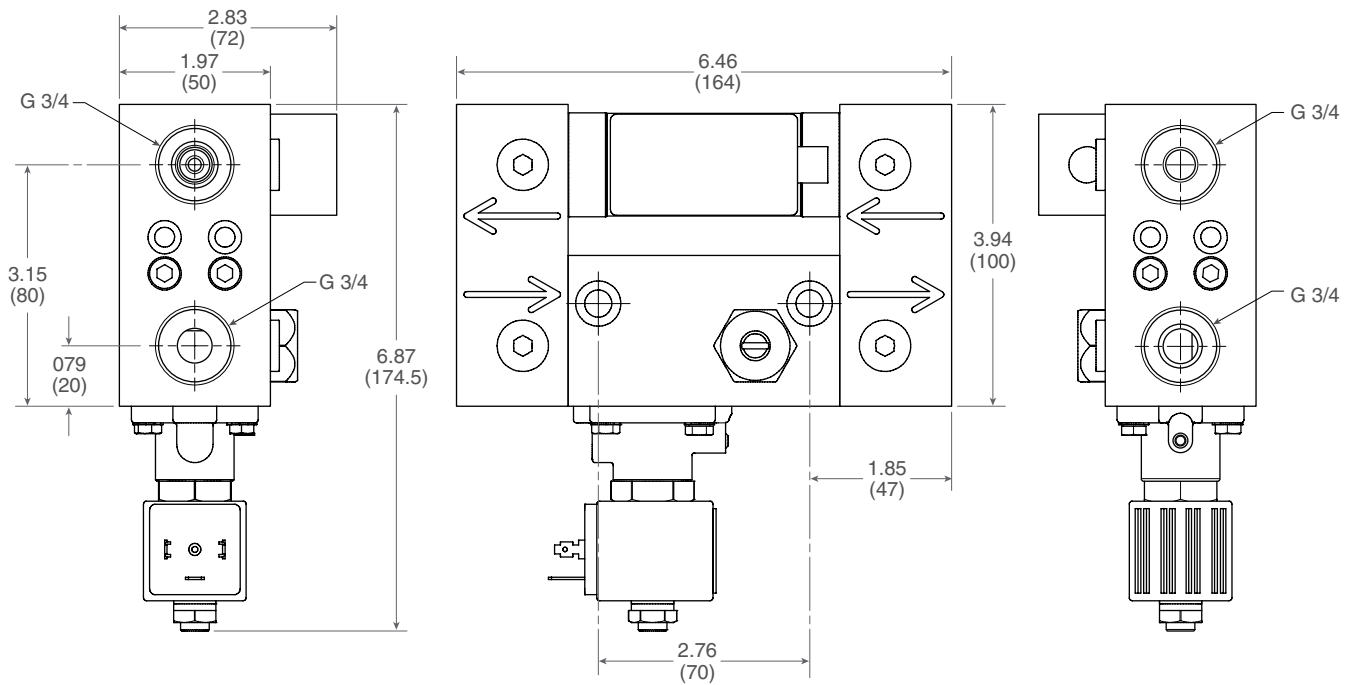



Catalog PCD2005-3 07/2013



Parker Hannifin Corporation
Parker Canada Division
160 Chisholm Drive
Milton, ON Canada
Tel: 905 693 3000
Fax: 905 876 1958
www.parker.com/canada/weld