

BDV Series

Ultra-High Purity Bulk Diaphragm Valve



Product Summary:

The BDV Series diaphragm valve enables precise control of gas and liquid distribution in semiconductor manufacturing processes. Excelling in high flow, low pressure conditions, it's ideal for bulk distribution systems, valve manifold boxes, and tool hook-up applications, where absolute purity and top-tier performance is the standard.

Key Characteristics:

- Operating pressure from vacuum to 300 psig (0-21 barg)
- 2.8 Cv flow capacity
- Fully traceable 316L stainless steel construction
- 10 μ inch Ra electropolished surface finish
- 1/4 to 1 in. port connections
- Assembled, tested, and packaged in Class 100 cleanroom
- "Positive retraction" tied diaphragm design
- Integrated Purge Ports Available

Quality — Precision — Reliability

BDV Diaphragm Valve

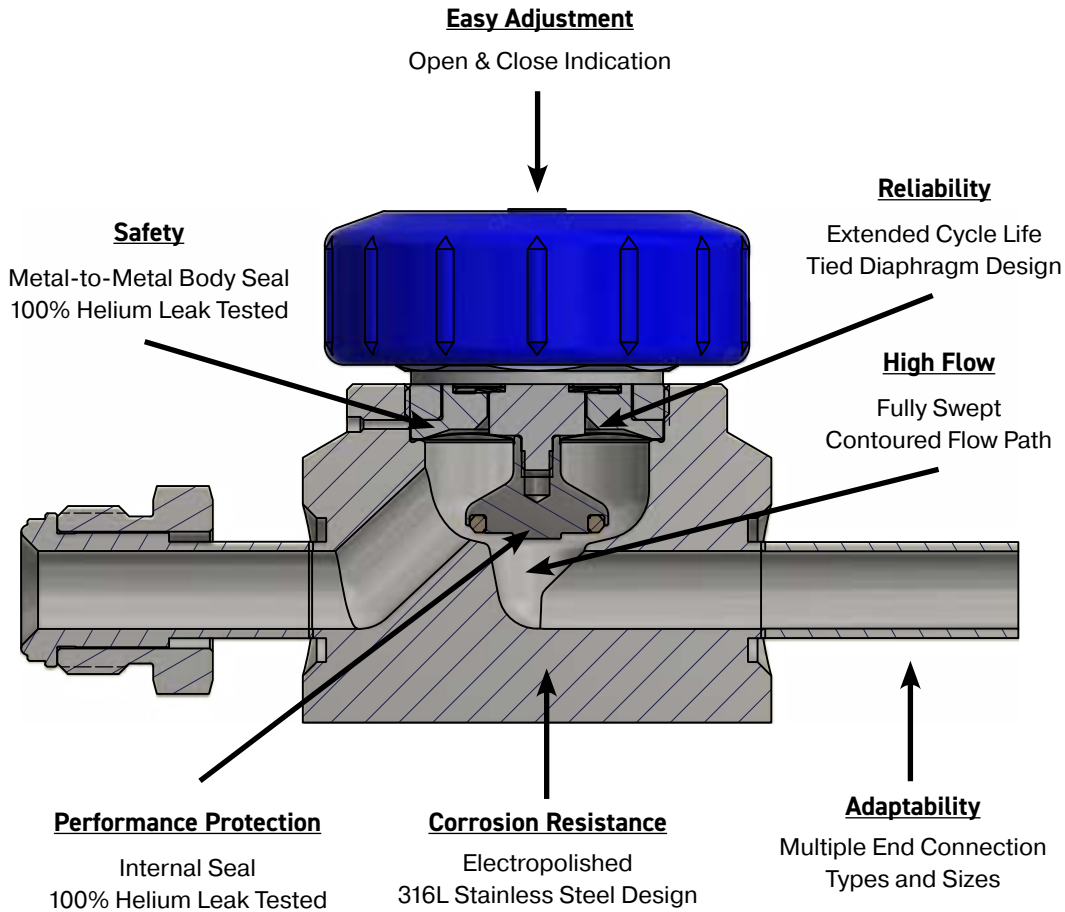

End Connections Available

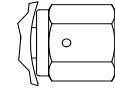

Female VacuSeal™

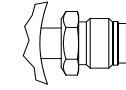

Male VacuSeal™



Tube Stub

Porting Configurations Available

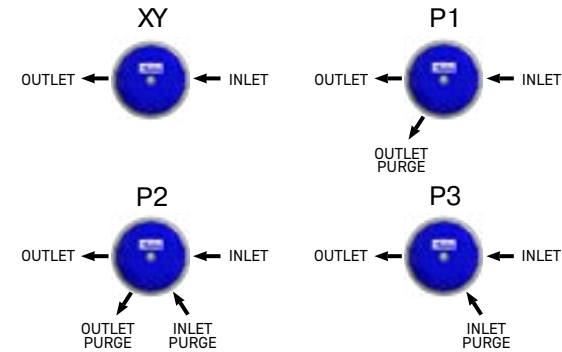

Applications



Bulk Gas Delivery



Tool Hook-ups



Valve Manifold Boxes (VMBs)

Product Catalogue (Click or Scan)



Parker.com/veriflo

© 2024 Parker Hannifin Corporation



ENGINEERING YOUR SUCCESS.