



Superheat Control

Installation and Operation Instructions

SPORLAN
S
P
O
R
L
A
N



Controller v. M.2



Contents

1. Installation	3	APPENDIX C	
2. Setup	4	Setpoint Parameters	17
Superheat Control with Display	4	APPENDIX D	
Superheat Control without Display	5	Accessories	19
Factory Reset	5	APPENDIX E	
3. Setpoint Menu Operation	5	Technical Specifications	19
4. System Operation	5	APPENDIX F	
Refrigeration	5	Controller Status	19
Chillers and Air Conditioners	6	APPENDIX G	
Control Features	6	Miscellaneous Displays	19
System Parameters	7	APPENDIX H	
5. Display Networking	9	Wiring Diagram	20
Multiple Controllers	10	APPENDIX I	
Junction Box Fabrication	10	Sensor Installation	21
6. Controller Networking	10	APPENDIX J	
Scaling	10	MODBUS Memory Map	22
Setup	11	APPENDIX K	
RS-485 Connection Requirements	11	BACnet Map	24
7. PID Tuning	11	APPENDIX L	
8. Troubleshooting	12	2K Temperature Sensor Specifications	32
Troubleshooting Recommendations	12	APPENDIX M	
Sensors	12	3K Temperature Sensor Specifications	33
Alarms	12	APPENDIX N	
APPENDIX A		10K Temperature Sensor Specifications	34
Setup Menu	15	Terms of Sale with Warranty Limitations	35
APPENDIX B			
Process Values	16		

⚠ WARNING – USER RESPONSIBILITY

Failure or improper selection or improper use of the products described herein or related items can cause death, personal injury and property damage.

This document and other information from Parker Hannifin Corporation, its subsidiaries and authorized distributors provide product or system options for further investigation by users having technical expertise.

The user, through its own analysis and testing, is solely responsible for making the final selection of the system and components and assuring that all performance, endurance, maintenance, safety and warning requirements of the application are met. The user must analyze all aspects of the application, follow applicable industry standards, and follow the information concerning the product in the current product catalog and in any other materials provided from Parker or its subsidiaries or authorized distributors.

To the extent that Parker or its subsidiaries or authorized distributors provide component or system options based upon data or specifications provided by the user, the user is responsible for determining that such data and specifications are suitable and sufficient for all applications and reasonably foreseeable uses of the components or systems.

For safety information see the Safety Guide at www.parker.com/safety or call 1-800-CParker.

OFFER OF SALE

The items described in this document are hereby offered for sale by Parker Hannifin Corporation, its subsidiaries or its authorized distributors. This offer and its acceptance are governed by the provisions stated in the detailed "Offer of Sale" available at www.parker.com.

FOR USE ON REFRIGERATION and/or AIR CONDITIONING SYSTEMS ONLY

For more information about our products visit us at www.sporlan.com.

Bulletin 100-50-5.1, May 2020 supersedes Bulletin 100-50-5.1, August 2016 and all prior publications.

Introduction

The **Sporlan Superheat Control** is a standalone controller for refrigeration and air conditioning systems. The controller operates an electronic expansion valve to control superheat. It may also be used to control room temperature. The controller may be networked into a building automation system and offers several communication protocols. It is available with or without display for aftermarket or OEM use. A remote display unit is optional.

Features

- Superheat or room temperature control
- 4-digit LED display with easy to use input knob
- OEM version available without display
- Optional remote display unit
- Optional display networking between controllers
- BACnet or MODBUS communication protocols
- One bi-polar or uni-polar step motor driver (30ohm/coil minimum)
- One mechanical relay output (for liquid line solenoid or piloting a compressor relay)
- Four temperature inputs (Sporlan surface or air sensor)
- One pressure input (Sporlan pressure transducer)
- One digital input (for external switch or relay)



Superheat Control
with display
Item Number 952567



Superheat Control
without display
Item Number 952568



Kelvin II
Remote display unit
Item Number 952568

1. Installation

Refer to *Appendix H - Wiring Diagram* and *Appendix I - Sensor Installation*

TOOLS REQUIRED:

- Small flat screwdriver for terminal connections
 - Phillips and flat screwdrivers
 - Cordless screwdriver
 - Needle-nose pliers
 - Wire cutters
 - Scotch-Brite™ pad
 - Two #8 x 1/2" self-tapping screws to mount DIN rail
1. Mount the controller in a rain-tight, protected location using the supplied DIN Rail. To leave enough working space, the suggested mounting area is 10 inches high and 5 inches wide. The minimum depth is 3 inches. See Figures 1 and 2.

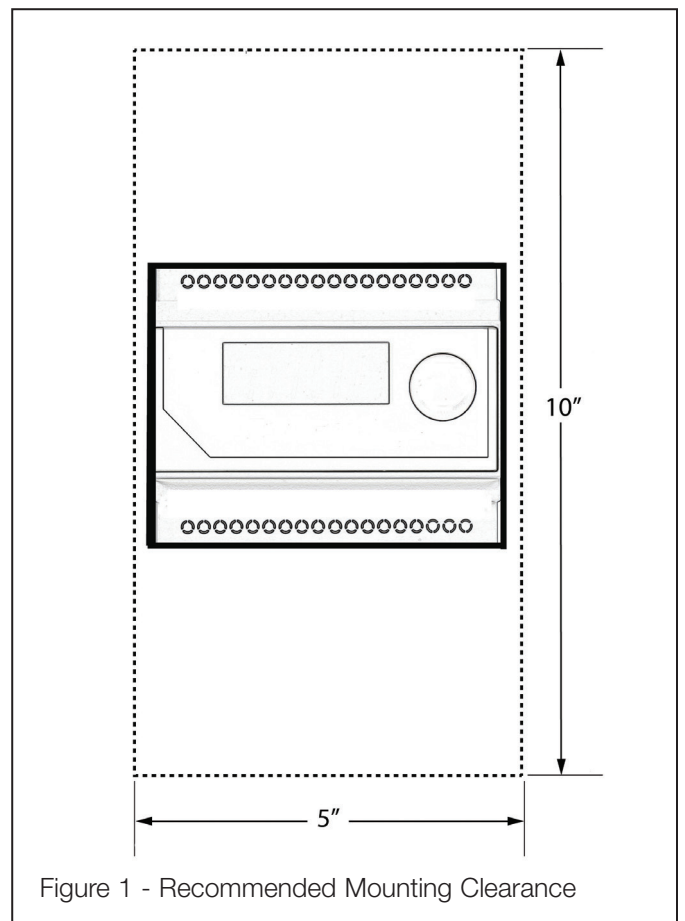

Figure 1 - Recommended Mounting Clearance

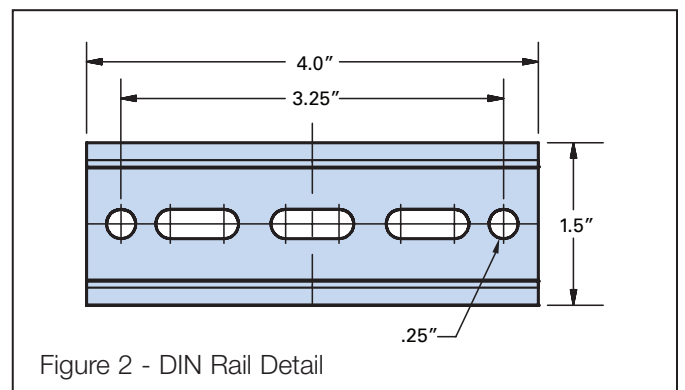



Figure 2 - DIN Rail Detail

Table 1 - Pressure Transducer Wire Colors

	CONTROLLER TERMINAL	OLD PIGTAIL LEADS	NEW HERMETIC CABLE
+5VDC	35	Red	Black
Signal	33	Green	White
Ground	34	Black	Green

2. Connect the suction temperature sensor wires to terminals 31 and 32. Sporlan temperature sensors are not polarized.
3. Connect the pressure transducer wires to terminals 33, 34, and 35. Sporlan has used transducer cables with two wire color combinations; see Table 1. **Maximum torque on screw terminals is 3.5 in-lbs.**
4. Connect the optional room temperature sensor wires to terminals 29 and 30. Sporlan temperature sensors are not polarized.
5. Connect terminals 27 and 28 to a digital input. A short or a closed contact from an external relay will close the valve for pump down. *See Section 4 - System Operation.*
6. Connect the Sporlan EEV wires to terminals 5, 6, 7, and 8.
7. Connect power wires to terminals 1 and 2. Transformer requirements are 24 volts AC/DC at 40 VA, Class II. The Sporlan supplied DC power supply is 100-250 VAC/24 VDC, P/N 953444.

NOTE: Sensor leads may be extended to 100 ft. (30.5 m) with 18 awg wires and Scotchlok™ UR connectors for long-term integrity. Belden wire is preferred; Transducer Cable Belden 9493, Temperature Sensor Belden 9409.

 **WARNING: Route and secure cables away from hot surfaces, high voltage lines, and moving components.**

NOTE: The Sporlan Superheat Control should be installed only by a qualified professional. All other system components (valves and sensors) should be supplied by Sporlan to ensure compatibility and proper operation. There are no user-serviceable components inside the Superheat Control. Opening the case will void the warranty.

 **WARNING: Use caution when working around high voltage components. Safety covers should be used for personal safety on high voltage panels.**

2. Setup

SUPERHEAT CONTROL WITH DISPLAY

The Superheat Control has preset setpoints for most system parameters. Basic system parameters will be verified through the setup menu. If additional parameter setpoints need to be changed, follow the steps in this section and in *Section 3 - Setpoint Menu Operation.*

Enter values for six system variables following the steps below. Refer to *Appendix A - Setup Menu.* The EEV is closed upon power-up and the system will not operate until completing setup. The controller will display the firmware versions for the display and the controller. It will then display the first variable to set.

1. Set **StEP**, Step Motor Stroke. Press and then turn the SELECT knob to select the correct number of steps for the EEV being used. See Table 2 for a list of Sporlan EEVs. Default is 2500. Press the SELECT knob again to save the value. The next variable is displayed.
2. Set **rEFr**, Refrigerant. Select the actual refrigerant used in the system, following the steps above. Default is R-404A.

NOTE: Verify the actual refrigerant used in the system.

3. Set **tT4P**, Temperature Sensor Type. Select 2K, 3K, 10K or 98.6K; see pictures below. Default is 2K.
4. Set **Pt4P**, Pressure Sensor Type. Select Absolute or Gauge (sealed), following the steps above. Default is Gauge.
5. Set **Un_t**, Temperature Units. Select Fahrenheit or Celsius. Default is Fahrenheit.
6. Set **Un_P**, Pressure Units. Select PSI or Bar. Default is PSI.

Setup is now complete. The Superheat Control will begin controlling superheat, and will display **SupH**. The controller is now in the Process Values Menu (Appendix B). Rotate the SELECT knob to view the values.



2K Air, Surface or Well Sensor



3K Surface Sensor



3K Air Sensor (Black)



10K Surface Sensor (Blue, Orange, or Red)



10K Air Sensor (Green or Yellow)



98.6K Surface Sensor

Table 2 - Electric Expansion Valves

SPORLAN MODEL NUMBERS	STEPS
SEI-5, SEI-1, SER-1.5, SEI-2, SEI-3.5, SEI-6, SER-6, SEI-11, SER-11, SER-20	1596
SER-AA, A, B, C, D, F, G, J, K, L	2500
SEI-30	3193
SEI-50, SEH-100, SEH-175	6386
ESX, OEV, SEV, SEV-C and CEV	500

NOTE: Not all refrigeration systems are designed alike. See Section 7 - PID Tuning to adjust the settings according to the specific needs of the system.

SUPERHEAT CONTROL WITHOUT DISPLAY

To set up a Superheat Control without display that is connected to either a Kelvin IId (remote display unit) or a Superheat Control with display, first go to Section 5 - Display Networking to establish a network connection.

Then follow the directions in this section and in Section 3 - Setpoint Menu Operation.

FACTORY RESET

It may be desired to set all of the setpoints of the control back to the factory defaults. Should that need arise, the user can perform this function by doing the following steps:

1. With the controller powered off, press and hold the knob on the display.
2. Power on the controller while the knob is still depressed.
3. The knob may be released once “Fr5t” is seen on the screen.

The controller will now require the user to complete the setup process before continuing.

3. Setpoint Menu Operation

See Appendix C - Setpoint Parameters. All setpoints must be verified prior to system startup for proper system operation. It may be necessary to adjust these parameters for a specific system. Details on advanced features can be reviewed in Section 4 - System Operation.

1. To enter the Setpoint Menu: Press the SELECT knob for 5 seconds. Enter the password “!!!” and press the SELECT knob again.
2. To view a parameter, rotate the SELECT knob to the desired parameter and press the knob. The default value will display.
3. Turn the SELECT knob to change the value and then press the SELECT knob to enter the value and return to the Setpoint Menu.
4. After all desired parameters are set, turn the SELECT knob to “ESC” and press the knob to save and implement all changes. Observe the system for proper operation.

NOTE: The Setpoint Menu times out after 60 seconds of inactivity and you will lose all changes entered.

The Superheat Control is now operational and displaying the Process Values Menu (Appendix B). To view system parameters while in operation, turn the SELECT knob and scroll through the menu. Select the desired parameter. For example, to view system superheat, turn the SELECT knob to *SupH*. After a few seconds, the actual system superheat will be displayed. See Appendix B – Process Values for a description of each variable.

Pressing the SELECT knob at any time will display the Controller Display Address *CAdr*.

4. System Operation

The Sporlan Superheat Control can be configured as a stand-alone superheat controller or a refrigerated space temperature controller. The controller can be used in refrigeration systems, chillers, or air conditioning systems. The Superheat Control should not be used inside of a conditioned space that exceeds product specifications (See Appendix E - Technical Specifications).

The controller, by default, is designed to control superheat in refrigerated spaces that use evaporator pressure regulators (EPRs). In all applications, it is recommended to use a normally closed solenoid valve upstream of the electronic expansion valve to ensure positive shutoff of refrigerant flow during power loss.

REFRIGERATION

Superheat control on cases with EEPR (preferred method): The Superheat Control will regulate the refrigerant flow entering the evaporator to achieve the superheat setpoint. The EEPR is typically controlled by a system level controller and provides consistent evaporator temperatures based on the discharge air setpoint (set through the system controller). This combination provides greater stability in control, increased efficiency of the evaporator coil, and accurate case temperatures.

Superheat control on cases with liquid line solenoid or suction stop solenoid valves:

Some applications in refrigeration that typically use mechanical expansion valves also use a solenoid valve upstream (liquid line) or downstream (suction stop) of the TEV to control case temperature. The system controller closes and opens the solenoid valve to meet cut-in and cut-out temperatures. If the Superheat Control is used on these systems in conjunction with an EEV, a digital input must be connected to the Auxiliary Temperature Sensor terminals (27 and 28 in Appendix H – Wiring Diagram). Since refrigerant flow is a critical part of the Superheat Control scheme, the controller must be tied into the liquid line solenoid or suction stop solenoid when flow is stopped. This input allows the controller to respond to major flow variations upstream or downstream of the EEV.

Case temperature control using cut-in / cut-out:

The Superheat Control can be used as a thermostat by connecting a room temperature sensor to T2, terminals 29 and 30, and setting *C_{in}* and *C_{out}* to the desired cut-in and cut-out temperatures, respectively. For optimum control, the room sensor must be located inside the case as specified by the refrigerated case manufacturer. Connect a normally closed liquid line solenoid valve to terminals 19 and 20. The solenoid valve should be wired so that the Superheat Control is cutting one leg of the supply voltage. Terminals 19 and 20 may also pilot a compressor relay in place of the liquid line solenoid on smaller standalone systems. Note relay ratings specified in the wiring diagram located in the appendix. The controller will maximize the efficiency of the evaporator coil by regulating

the EEV to control superheat until the cut-out temperature is reached. The solenoid valve and EEV will then close until the temperature rises to the cut-in temperature. Once the valves close and refrigeration stops, the Superheat Control will display *OFF*. During refrigeration mode, the controller will display *COOL*. During defrosts, the system master controller must provide a digital input/short to terminals 27 and 28. The Superheat Control will close the EEV and display *Pdn* for pumpdown. A standard dry contact relay can be used. A minimum relay on and off time can be set for the solenoid valve. See *ront* and *roff* features under the Parameters Section.

CHILLERS AND AIR CONDITIONERS

Superheat control - Single evaporator:

The Superheat Control may be used on single evaporator chillers or air conditioners. The default control scheme is optimized for quick pull down (coil temperature) and stable holding loads. If the controller is used on systems with major transient conditions (impulse heat loads) it may be necessary to adjust the PID control scheme parameters. See *Section 7 - PID Tuning*.

Superheat control - Dual evaporator:

On some systems, it may be necessary to control two independent evaporator coils. This setup will consist of a Superheat Control with display and a Superheat Control without display. A network must be established between the two controllers; see *Section 6 – Controller Networking*. The display can be used to set up both controllers and to review parameters from each evaporator coil.

CONTROL FEATURES

Pumpdown

Closing or shorting terminals 27 and 28 (T3) places the controller in pumpdown mode and closes the EEV. A standard dry contact relay can be used. During pumpdown signal, the Superheat Control will open terminals 19 and 20 (relay), which can be used to pilot a solenoid valve or compressor. During this time, the controller will shut down the control scheme and prepare for restart. This ensures maximum control efficiency and system stability.

Manual Valve Positioning

The Superheat Control can be used to manually position the EEV via a local or remote display. To access manual valve control, navigate to the Setpoint menu, scroll to *SPoS* and press the SELECT knob. Once this is selected, the controller no longer controls the superheat or case temperature setpoint. The display will show the actual valve position, from 0% to 100% open once the SELECT knob is pressed. To open the valve, turn the select button clockwise. To close the valve, turn the select button counter-clockwise. To end manual valve control, press the SELECT knob to go back to the Setpoint menu. At this point, the controller will resume normal operation.

The controller has an internal timeout function and after 60 minutes of inactivity, normal operation will resume. For troubleshooting purposes, the timeout may be disabled using the Stepper Timeout Override (*SttO*) feature. This may

be accessed through the Setpoint menu and placed in the *on* position to override the timeout. It should be noted that the setpoint parameter menu must be exited before changes are saved. The valve position shown under *SPoS* will blink when the timeout is disabled.

If manual valve control is needed without viewing system parameters use the following steps:

1. Through the display, press and hold the SELECT knob until *EntR PASS* appears.
2. Enter “111” by turning the knob.
3. Scroll to *SPoS* feature and hold down the SELECT knob until the position on the display starts blinking (10 seconds). This will override the time out feature.
4. To move the valve, rotate the SELECT knob. The controller will remain in manual mode until the SELECT knob is pressed.

If manual valve control is needed while viewing system parameters use the following steps:

1. Through the display, press and hold the SELECT knob until *EntR PASS* appears.
2. Enter “111” by turning the knob.
3. Scroll to *SttO* feature and press SELECT knob.
4. Turn selection to *On*.
5. Push the SELECT knob and scroll to *ESC*.
6. Press the SELECT knob; the controller is now locked in manual mode.
7. To manually move the EEV press and hold the SELECT knob until *EntR PASS* appears.
8. Enter “111” by turning the knob.
9. Scroll to *SPoS* feature and press SELECT knob.
10. Rotate the knob to move the EEV. The position on the display is shown % open and will be blinking while in manual control.
11. To exit manual valve control, use the steps above and select *OFF* under *SttO*; exit parameter setpoint menu to save changes and continue automatic control.

Manual valve control through MODBUS:

1. Enable the feature by writing a 1 to the “Manual Valve Enabled” coil using the ‘Write Single Coil’ function. See *Appendix J – Modbus Memory Map*.
2. Manually move the valve by writing the position, tenths of a percent, to the “Manual Valve Position” holding register using the ‘Write Single Register.’ Each time a write is sent to the controller, the manual timeout feature resets.

Manual valve control through BACnet:

1. Enable the feature by writing a 1 to the “MANUAL_VALVE_CONTROL” binary value object’s present value property. See *Appendix K – BACnet Map*.
2. Manually move the valve by writing the position, in tenths of a percent, to the “MANUAL_VALVE_POSITION” analog value object’s present value property. Each time a write is sent to the controller, the manual timeout feature resets.

NOTE: Use caution and monitor superheat while in manual valve mode. To avoid floodback, start with the valve in a low position. Never leave the system unattended while in manual mode.

SYSTEM PARAMETERS

Addr (Address) – The MODBUS or BACnet network address must be set on each Superheat Control if they will be installed on a network. No two controllers may have the same address on the network. The Superheat Control has been designed to have addresses for both the controller and the display. It should be noted that this parameter, *Addr*, is for the controller, not the display.

brud (Baud Rate) – Baud rate refers to the number of signal changes that occur per second via the communications line on the network. The MODBUS or BACnet baud rate must be set to the same rate as the master controller or other devices on the network.

b_5t (Bleed Step Position) – The EEV will be placed in the bleed position to allow for refrigerant equalization in the system after the unit is signaled to shut down via a short across terminals 27 and 28. The bleed position works in conjunction with *b_dl*, bleed delay feature. The default bleed position is 0%. See below for more information.

b_dl (Bleed Delay) – The bleed delay feature works with the *b_5t*, bleed step position feature. Once the system gets a signal to shut down via a short across terminals 27 and 28, the EEV will close to 0% then dwell for the bleed delay time, in seconds, before moving to the bleed delay position for system pressure equalization. The default bleed delay time is 0 seconds. See below for more information.

Bleed System Equalization (*b_5t*, *b_dl*)

Use of an EEV can dramatically improve efficiency of a refrigeration or air conditioning system. By accurately controlling the system's superheat, the EEV achieves full utilization of the evaporator coil surface area. A drawback to the use of EEVs with some compressors is the need for off-cycle pressure equalization of high to low system pressure. Specifically, when the system is off the compressor is not cycling refrigerant and the EEV is closed. This keeps refrigerant from flowing through the system. This condition can cause high backpressure on the discharge side of the compressor, and hence, a hard start condition. Setting a Bleed Step Position, *b_5t*, allows a small amount of liquid refrigerant to pass through the EEV while the system is off. Normal industry practice is to set a bleed to equalize the system in 3-5 minutes. The Superheat Control also allows the delay of the bleed process by setting the Bleed Delay parameter, *b_dl*.

CDr (Controller Display Address) – The display address must be set when viewing multiple Superheat Controls through a single display. If a display network is not used between controllers, the *CDr* must remain at default values. No two controllers may have the same address on the network. The Superheat Control has been designed to have addresses for both the controller and the display. It should be noted that this parameter, *CDr*, is for the display, not the controller. See 'Display Networking' section for more information.

cin (Cut In Temperature) – The cut in feature may be used if case temperature control via cut in/cut out is desired. It is used with the Cut Out feature, *cout*. The Superheat Control will start the system once the case temperature rises to the cut in temperature setpoint. The refrigeration mode will remain

on until the case temperature falls to the cut out temperature setpoint. To activate this feature, adjust the cut in temperature setpoint to the desired value. See 'System Operation' section for further description.

cout (Cut Out Temperature) – The cut out feature may be used if case temperature control via cut in/cut out is desired. It is used with the Cut In feature, *cin*. The Superheat Control will stop the system once the case temperature falls to the cut out temperature setpoint. The refrigeration mode will remain off until the case temperature rises to the cut in temperature setpoint. To activate this feature, adjust the cut out temperature setpoint to the desired value. See 'System Operation' section for further description.

CRP (Calibration Pressure Sensor) – The Superheat Control has adjustable calibration offsets for the pressure sensor. By default, it is set to 0. This parameter may be adjusted to compensate any error with the pressure sensor.

CLT1 (Calibration Temperature Sensor T1 Suction) – The Superheat Control has adjustable calibration offsets for the temperature sensors. By default, it is set to 0. This parameter may be adjusted to compensate any error with the temperature sensor.

CLT2 (Calibration Temperature Sensor T2 Room) – The Superheat Control has adjustable calibration offsets for the temperature sensors. By default, it is set to 0. This parameter may be adjusted to compensate any error with the temperature sensor.

CLT3 (Calibration Temperature Sensor T3) – The Superheat Control has adjustable calibration offsets for the temperature sensors. By default, it is set to 0. This parameter may be adjusted to compensate any error with the temperature sensor.

CLT4 (Calibration Temperature Sensor T4) – The Superheat Control has adjustable calibration offsets for the temperature sensors. By default, it is set to 0. This parameter may be adjusted to compensate any error with the temperature sensor.

-d (Derivative Control Gain) – The derivative gain is part of the PID control scheme. In general the derivative gain effects the speed of the electronic valve in response to the rate of change in superheat error. The derivative gain is sensitive to noise and if set too high the valve may overreact and system oscillations may occur. The derivative gain is generally set to 1 for most systems. See PID tuning section for more information.

dbnd (Dead Band) – This feature provides a smoother operational range around superheat setpoint. For tighter superheat control, the dead band may be decreased. The Superheat Control has +/- 2°F and +/- 1°F options.

d_on (Delay On) – This feature sets a delay time before energizing terminals 19 and 20 after the EEV reaches the Delay Percent Open position set by *d_5t*. It may be used on small single compressor systems to position the EEV prior to starting the system. If the Superheat Control gets a signal to start the system (remove dry contact/short across terminals 27 and 28), it moves the EEV to the Delay Percent Open position, energizes the relay terminals 19 and 20 after the Delay On time has been met. Delay On time is in seconds and starts when the EEV is at the Delay Percent Open position. Terminals 19 and 20 can be used to pilot a compressor relay.

doFF (Delay Off) – This feature sets a delay time before de-energizing terminals 19 and 20 after the EEV reaches 0% position. If the Superheat Control gets a pumpdown signal to shut off the system (dry contact/short across terminals 27 and 28), it closes the EEV and waits for system pumpdown by the specified Delay Off time, then de-energizes the relay terminals 19 and 20. Delay Off time is in seconds and starts when the controller receives a pumpdown signal or enters ‘OFF’ mode. Terminals 19 and 20 can be used to pilot a compressor relay.

d_oP (Delay Percent Open) – This feature is used in conjunction with delay on, *d_on*, and is used to help equalize system pressure prior to starting smaller, standalone systems. The EEV position will move to the percent open position for the time set by *d_on*.

H_CP (Max Valve Capacity) – The maximum valve capacity feature can be used to limit the EEV opening. This may be used to compensate for an improper, oversized EEV. If set too low however, system superheat may become too high.

H_oP (Maximum Operating Pressure) – This feature can be used on various systems to limit the suction pressure. The Superheat Control limits the amount of suction gas going to the compressor by closing the EEV when pressure is within 3 psi of the maximum operating pressure setpoint.

hPA (High Pressure Alarm) – The high pressure alarm can be deactivated. The alarm, by default, is turned on to alert against high system pressure. For certain low pressure systems, it may be necessary to turn this feature off to avoid nuisance alarms during system off time. With the alarm deactivated, the Superheat Control will still continue to take action and attempt to reduce system pressure by regulating the EEV when high pressure is detected. It should be noted that superheat control takes priority as a safeguard.

hShd (High Superheat Alarm Delay Time) - The high superheat alarm trigger may be delayed by adjusting the High Superheat Alarm Delay time. Decreasing the setting will trigger the alarm sooner. Increasing the setting will extend the time before an alarm is triggered. The setting is in minutes.

hSHF (High Superheat Failsafe) - When the High Superheat Failsafe is placed in the ‘on’ position, the EEV will close to 0% position after the High Superheat Alarm Delay time (h5hd) has passed. The EEV will remain at 0% until the controller is manually repowered, This setting is ‘off’ by default.

-I - (Integral Control Gain) – The integral gain is part of the PID control scheme. In general the integral gain affects the electronic valve response over a given time period to bring the steady state error to zero. See PID tuning section for more information.

L_oP (Low Operating Pressure) – This setting can be used in smaller systems to aid in startup. If the EEV is not open enough during start up (superheat above setpoint and pressure below the low operating pressure setpoint) the Superheat Control will automatically open the EEV to equalize system suction pressure to maintain mass flow and keep the system running. It will go back to superheat control when suction pressure rises above *L_oP* setpoint. It should be noted that superheat control takes priority as a safeguard.

LShd (Low Superheat Alarm Delay Time) - The low superheat alarm trigger may be delayed by adjusting the Low Superheat Alarm Delay time. Decreasing the setting will trigger the alarm sooner. Increasing the setting will extend the time before an alarm is triggered. The setting is in seconds.

LShi (Low Superheat Integral) – The EEV response to low superheat can be adjusted by increasing the low superheat integral. By increasing this number, the EEV will close faster when superheat falls below 2°F. In general, if low superheat conditions exist for more than 3 minutes in normal operation, increase the low superheat integral. It is recommended that the low superheat integral be adjusted slightly above the normal PID integral to help safeguard against low superheat conditions.

nEt (Network Communication Protocol) – The Superheat Control offers MODBUS and BACnet communication protocols. The Superheat Control has been designed following industry standard specifications. For system set-up and implementation, reference the following documents:

MODBUS – www.modbus.org

MODBUS Serial Line Protocol and Implementation Guide v1.02

MODBUS Application Protocol Specification v1.1b3

BACnet – ANSI/ASHRAE Standard 132-2012

nPAR (Network Parity) – An even or odd parity bit is used for error checking when transmitting a string of binary code via MODBUS and BACnet. A check bit is added to the end of the string. The Superheat Control also offers a “no parity” selection to meet the BACnet standard. It is important to configure the Superheat Control and the master controller with the same network parity. The following chart shows an example.

8 BITS OF DATA	COUNT OF "1" BITS	9 BITS INCLUDING PARITY	
		EVEN	ODD
00000000	0	000000000	000000001
10100010	3	101000101	101000100
11010010	4	110100100	110100101
11111110	7	111111101	111111100

-P- (Proportional Control Gain) – The proportional gain is part of the PID control scheme. In general the proportional gain effects the speed of the EEV in response to the superheat error. If the proportional gain is too low, the valve may be too slow to respond. If it is too high, the valve may overreact and system oscillations may occur. See PID tuning section for more information.

PrnR (Pressure Sensor Range) – The pressure sensor range must be configured to properly measure suction pressure. Suction pressure is used to calculate superheat and establish a minimum and maximum operating pressure, set by *L_oP* and *H_oP* respectively. The Superheat Control offers several pressure range options based on system design and refrigerant pressure. When *Auto* is selected, the Superheat Control will automatically set the pressure range based on the following refrigerant criteria:

R-410A: uses 0-300 psig

R-744 (Subcritical): uses 0-500 psig

All other common refrigerants: 0-150 psig

Ensure that this setpoint matches the corresponding pressure sensor used on the system.

PTYP (Pressure Sensor Type) – The pressure sensor type, such as gauge pressure, must be set correctly to properly measure suction pressure. Ensure that this setpoint matches the corresponding pressure sensor used on the system.

REFR (Refrigerant Type) – The system refrigerant type must be set up in order to calculate and maintain superheat. The Superheat Control has a list of commonly used refrigerants.

ront (Relay On Time Minimum) – The amount of time, in minutes, that the output of the relay terminals 19 and 20 must remain on after it is energized. See below for more detail.

roft (Relay Off Time Minimum) – The amount of time, in minutes, that the output of the relay terminals 19 and 20 must remain off after it is de-energized. See below for more detail.

On standalone systems, the **ront** and **roft** feature may be used to prevent compressor short cycling when the Superheat Control is used as a thermostat and Cut In/Cut Out temperature control is desired. The parameters **Lin** and **Lout** must be set as the temperature control range along with installation of the room sensor, T2, to terminals 29 and 30. The minimum on and off relay parameters should be set according to the compressor manufacturer recommendations. When the Superheat Control receives a pump down or call for defrost from the dry contact at T3 temperature sensor input, terminals 27 and 28, the system will not execute the procedure to pump down until the minimum relay time has expired.



WARNING: The default setting for the Minimum Relay On and Off time is 0 minutes. For a standalone system these values may be adjusted to prevent compressor short cycling.

NOTE: Use caution. An oversized compressor can cause low case temperature during Minimum Relay On Time cycle set by **ront.**

SHSP (Superheat Setpoint) – The superheat setpoint is the control variable. The Superheat Control uses system suction pressure and temperature to calculate and maintain superheat for a given refrigerant type.

SPoS (Stepper Position) – The EEV position is shown on the display real time in percent open. The position may also be read through MODBUS or BACnet.

Stto (Stepper Timeout Override) – When the Stepper Timeout Override is placed in the ‘on’ position, the system will remain in manual valve mode indefinitely and the standard 60 minute timeout will be disabled. It should be noted that the setpoint parameter menu must be exited before changes are saved. The valve position shown under **SPoS** will blink when the timeout is disabled. See Advanced Features section for more information on manual valve mode.

NOTE: Use caution and monitor superheat while in manual valve mode. To avoid floodback, start with the valve in a

low position. Never leave the system unattended while in manual mode.

StEP (Stepper Valve Type/Stroke) – The electronic valve type must be set correctly to match the valve that is used on the system. The type refers to the valve stroke, which typically is 2500 or 6386 steps.

SupS (Supermarket Mode) – Supermarket Mode may be used on large refrigeration systems; typically on controllers that are used in refrigerated case line ups. This mode has a unique algorithm to improve both case temperature pull down and steady state control. If the Superheat Control is used on standalone systems or systems with quick transient changes in load, it is recommended to turn this mode off and manually tune the PID parameters for the system. See PID tuning section for more information.

Temp (Temperature Sensor Type) – The temperature sensor type, such as 3K, must be set correctly to properly measure temperature and calculate superheat. The Superheat Control offers several types of temperature sensors; however, all temperature sensors must be of the same type per controller. Ensure that this setpoint matches the corresponding temperature sensor used on the system.

Un_P (Unit Type Pressure) – The pressure sensor units, such as PSI, must be set correctly to properly measure and display suction pressure.

Un_t (Unit Type Temperature) – The temperature sensor units, such as Fahrenheit, must be set correctly to properly measure and display temperature.

5. Display Networking

A Kelvin IId remote display unit can be connected to another Superheat Control in order to set up that controller, view that controller’s process values, and change setpoints.

To network a Superheat Control without display with a Kelvin IId (remote display unit):

1. Connect the two controllers with a Cat-5 Ethernet cable.
2. The remote display unit will access the Superheat Control.
3. Set up the Superheat Control (*Section 2 - Setup*).

To network a Superheat Control without display with a Superheat Control (with display):

1. Connect the 2 controllers with a Cat-5 Ethernet cable.
2. The Superheat Control with display must have its **CADr** parameter (Display Address) set to **1-99** to enable display networking. Navigate to “**End**” in the process variables display of the Superheat Control with Display and press the SELECT knob to select a different controller on the display network. (Controller should display “**LoCL**”)
Note: “End” is not available if “CADr” is 0.
3. Turn the SELECT knob to find the Superheat Control without display (**2** is default for the Superheat Control without display), and press the knob to connect.
4. After a connection is established the display should switch from “**----**” to the firmware version of the Superheat Control with display followed by the setup screen (if the controller has not been set up as described in Section 2).

Figure 3 - Display Networking

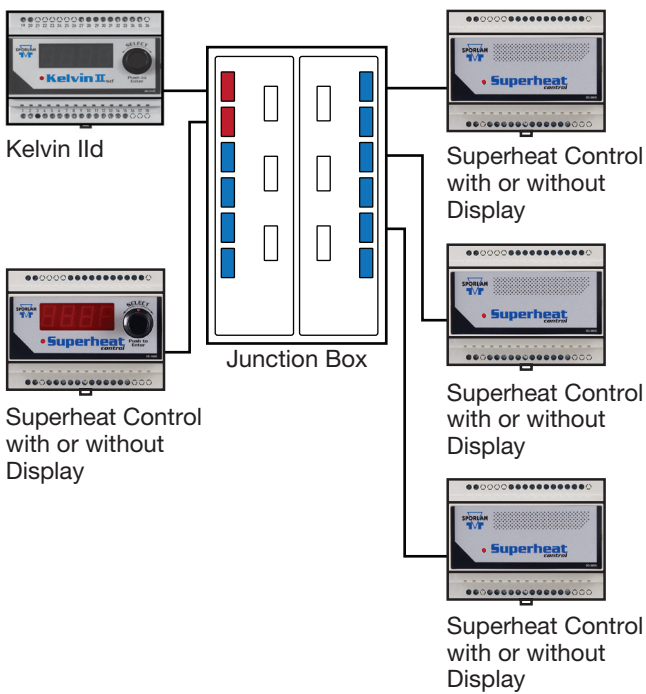
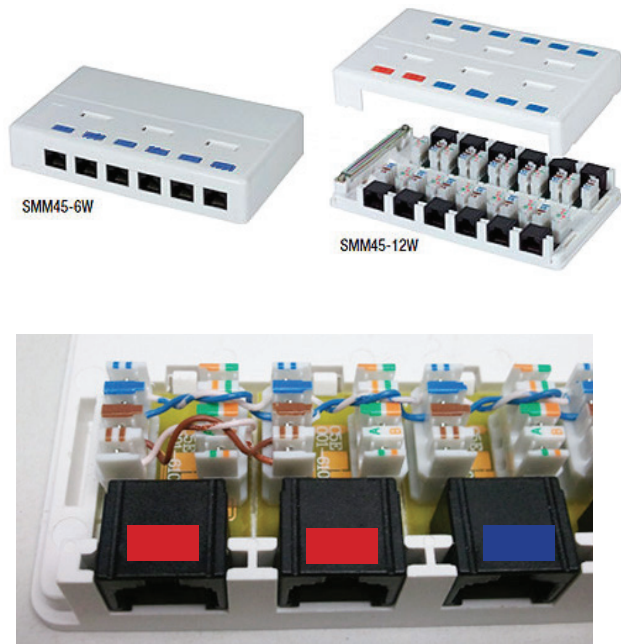

Figure 4 - Wiring the Powered (Red) Jacks



The local controller is listed as *LoCL*. To view a different controller on the display network, rotate the SELECT knob to the *CRdr* and then press and release the knob. Rotate the knob to select the address of a controller. Once the address is selected it will take a moment to boot up. Setpoints on any controller can be changed as described in *Section 3 - Setpoint Menu Operation*.

The *CRdr* of a Superheat Control without display can also be set through Modbus.

Multiple Controllers

The *CRdr* of a Superheat Control without display, display address 3-99, must be set individually using a Kelvin IId or through Modbus.

Three or more controllers can be networked through the use of a special junction box that is easily fabricated. The controllers are wired to the junction box using the RJ-45 jacks and Cat 5 Ethernet cable (see *Figure 3 - Display Networking*). Superheat Controls can connect to any junction box ports. Unpowered remote display units (Kelvin IId) should be connected to specially wired ports designated for the remote display, shown in red in Figure 4.

Junction Box Fabrication

Category 5E junction boxes can be sourced from L-com.

- Model SMM45-6W can connect 6 controllers (1 remote display and 5 Superheat controllers with or without displays).
- Model SMM45-12W can connect 12 controllers.

Junction boxes may be daisy-chained to extend the number of Kelvin II Controls on the network. Kelvin IId remote displays, being unpowered, must be connected to an energized port (red

jacks in Figure 3), with a powered controller plugged into the other red jack. If all the networked controllers are powered models, no special wiring (red jacks) is necessary.

To wire a junction box, punch down all blue and blue/white wires. To wire a pair of energized (red) jacks, punch down brown and brown/white wires between 2 jacks. See Figure 4.

6. Controller Networking

The Sporlan Superheat Control can communicate with a Modbus RTU communication master or BACnet MSTP master via RS485. See *Appendix J - Modbus Memory Map* and *Appendix K - BACnet Map*.

The serial settings are:

- 9600 baud (default), 19200 baud, 38400 baud
- 8 data bits
- 1 stop bit
- Even parity (default), odd parity, no parity

Scaling

For better precision, scaling is used for Bar or Celsius units. PSI and Fahrenheit are whole numbers and have no scaling.

Celsius values transferred via Modbus are 10X. For example, a value of 45 will be transferred for the superheat when the actual superheat temperature is 4.5°C. Remember this when changing a setpoint.

Bar values transferred via Modbus are 100X. For example a value of 1034 will be transferred for the Maximum Operating Pressure when the actual pressure is 10.34 Bar. Remember this when changing a setpoint.

Figure 5 - RS-485 Wiring

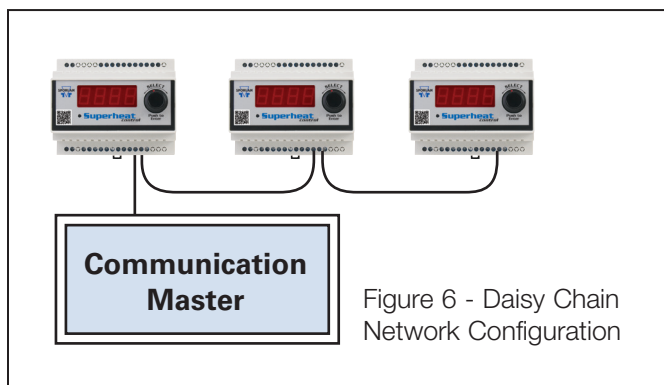
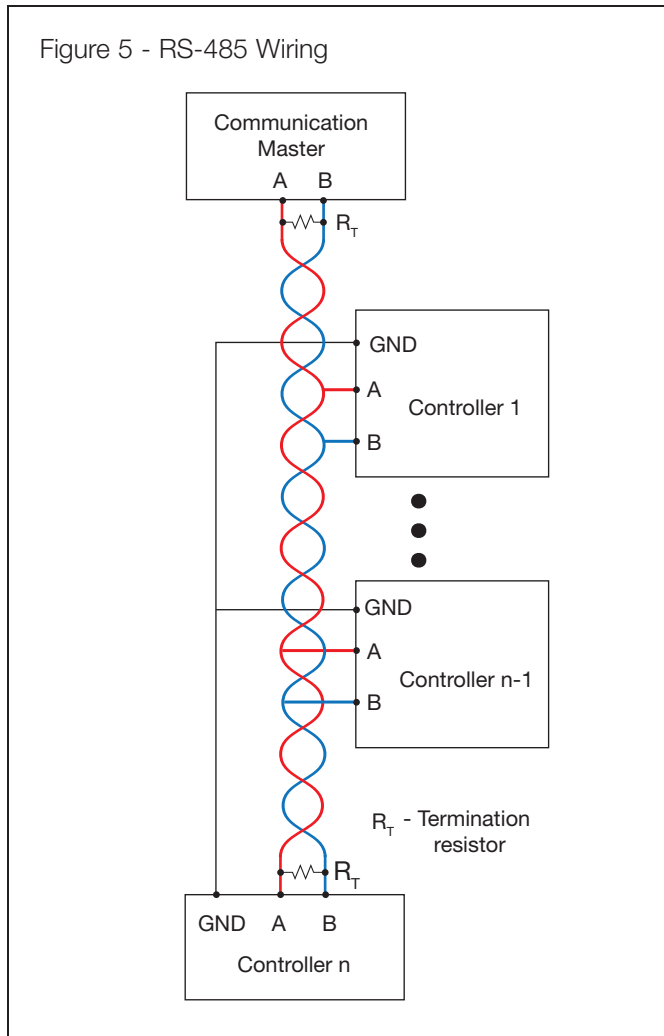

Figure 6 - Daisy Chain Network Configuration

Setup

The Sporan Superheat Control can be networked to communicate process variables back to a master controller. This information can be used for verifying system performance or updating individual setpoints via RS-485 and PC interface. Data can be accessed remotely through the master controller. For further information on remote monitoring, see the documentation for the master controller.

Prior to connecting the network, each controller must be assigned a separate address on the Modbus or BACnet network, $Addr$. Refer to *Section 3 – Setpoint Menu Operation* to enter the Setpoint menu. Once in the Setpoint menu, scroll to $Addr$ and assign each controller on the network an individual

address. Note that no two controllers can have the same address. Default address for each controller is '1'.

NOTE: $Addr$ is the controller's RS-485 address and $CAAddr$ is the controller's display address.

RS-485 Connection Requirements

See *Figure 5 - RS-485 Wiring*.

Wire Type: Use Belden 8760 or equivalent

Maximum Number of Network Nodes: 100

Maximum Run Length: 4000 ft

Recommended Network Configuration: Daisy Chain, a single continuous transmission line from one end to the other. Other configurations involving triple-lug connections, such as star, are not recommended. See Figure 6.

Noise Reduction: Termination resistance (R_T in Figure 5) is recommended to reduce reflections and noise on the data transmission lines. Place the resistance at the extreme ends of the cable, with the resistance value matching the characteristic impedance of the transmission line (typically 120 ohms for twisted pair cables).

Shielding prevents noise from EMI sources. If the cable is shielded, connect the shield to earth ground at one end only.

NOTE: Do not connect shield to RS485 GND.

Keep RS485 wiring away from high voltage AC lines to reduce noise and data errors on the communication lines. RS485 communication cable should be placed perpendicular to AC lines at any intersection.

Grounding: Connect a third conductor to RS485 GND (terminal 13) to prevent ground potentials between nodes. This conductor should be included in the shield of the twisted pair cable to prevent noise. **NOTE: Do not connect RS485 GND to earth ground.**

Third Party Controllers: To avoid nuisance "network errors", the use of third-party controllers on the same RS485 network with Sporan controllers is not recommended.

Refer to the documentation supplied with the communication master for additional RS485 network requirements.

7. PID Tuning

If temperature pull down is satisfactory, then the default control scheme (supermarket mode) should be used. The PID values may be adjusted if superheat is not stable. If superheat is oscillating around setpoint at steady state conditions, reduce PID settings to half of existing values. If pull down is not satisfactory, then the Superheat Control can be configured into a standard PID scheme that can be fully adjustable. This feature can be accessed by entering the Setpoint Parameters Menu as described in Section 3. Go to parameter $SuPS$, supermarket mode, and change its value to OFF .

NOTE: Only experienced professionals should access this feature. System stability and performance may be improved by adjusting PID.

The Superheat Control is factory programmed with default Proportional–Integral–Derivative (PID) settings that will

provide efficient control. It may be necessary, however, to fine tune the PID settings in applications where systems experience rapid transient conditions (such as frequent “impulse” changes in loading or mass flow rates).

In most instances, adjustments to the PI setpoints are adequate. If tuning is needed, see *Section 3 - Setpoint Menu Operation* to enter the PID setpoint menu. The following guidelines should be followed:

- P- (Proportional Coefficient) - Increase value to increase valve response to superheat.
- I- (Integral Coefficient) - Increase value to increase valve response to superheat over a given time period.
- d- (Derivative Coefficient) - Increase value to increase valve response to rate of change in superheat.

When PID adjustments are made, allow adequate time for the system to respond to the changes.

When the superheat is oscillating to extremes, the Proportional and/or the Integral value may be too high. If superheat is slow to react to a transient system change, then the Proportional and/or the Integral value may be set too low.

NOTE: Not all refrigeration systems are designed alike. Use caution when tuning PID setpoints.

8. Troubleshooting

Troubleshooting Recommendations

As with any refrigeration component troubleshooting, actual system conditions should be verified with a gauge set and a calibrated temperature sensor (i.e verify actual superheat and refrigerant condition). This system information is valuable in determining whether it is component related or system related.

For systems or applications that experience light loads on the Superheat Control circuit, it is important that the heat exchanger and refrigerant lines are sized correctly. This will ensure proper oil return and will minimize the effects of oil logging in the heat exchanger. Many heat exchanger manufacturers recommend a hot gas bypass for loads below 50%.

Sensors

Failed sensors will trigger an alarm. An alarm code will show which sensor is mis-wired, disconnected, or faulty. The alarm will persist until the problem is corrected.

Failed temperature sensors may read extremely low or infinite resistance when tested with an ohmmeter. Readings should be taken with the sensor disconnected from the Superheat Control. A missing or disconnected temperature sensor will read **-50** on the controller.

Temperature sensor output can be checked by measuring the DC voltage across the sensor wires and consulting the tables in *Appendices L, M, N*.

Pressure transducers must be installed tight enough to depress the valve stem in the fitting. Failure to do so will result in erroneous pressure readings and possibly leaks.

Table 3 - Pressure Transducer Specifications

LABEL COLOR	Range	PSI
Green	150	(v-.5) x 37.5
None / Silver	300	(v-.5) x 75
Yellow	500	(v-.5) x 125
Pink	652	(v-.5) x 163

Pressure transducers should be tested while connected to the controller and powered. Test at the controller terminals. Voltage between terminals 34 and 35 should be 4.8 - 5.2 volts DC. Voltage between 33 and 34 should be between 0.5 and 4.5 volts DC. See *Table 1 - Pressure Transducer Wire Colors*.

To test the accuracy of the transducer, use a gauge set to obtain the actual system pressure. For volts-to-pressure conversion, measure the voltage between terminals 33 and 34. Identify the pressure transducer used and find the correct range **Range** in *Table 3*. Substitute the measured voltage (v) into the formula in the PSI column. The result should be within 3 psi of the actual system pressure shown on the gauge set. If not, check the transducer for proper installation, correct Schrader valve, and verify the pressure range identified on the transducer.

To test the transducer cable, disconnect the cable from the transducer and check for 4.8 - 5.2 volts between terminals + and -. See *Figure 7 - Pressure Sensor Cable*.

Figure 7 - Pressure Sensor Cable

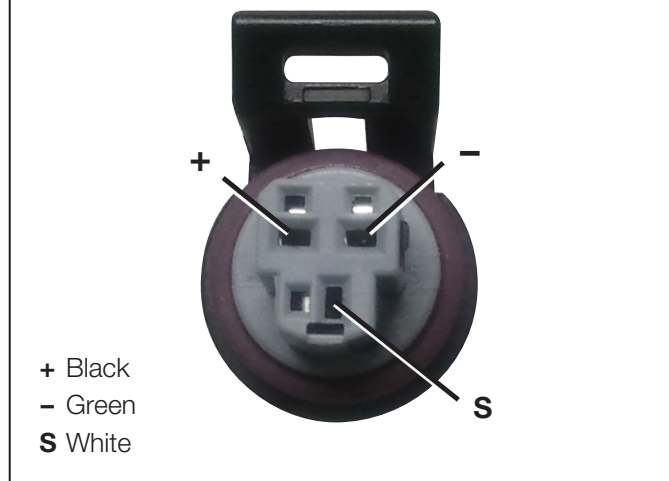

Alarms

The Superheat Control will display **-AL-** when the system detects a fault. The alarm feature notifies the user on the display and through MODBUS or BACnet (when used). During alarm, a voltage difference will occur across terminals 11/12 to support an external alarm relay. Note: Terminal 11 is not part of the controller’s ground. See *Table 4* for a list of alarms.

Troubleshooting

SYMPTOM	CHECK
Will not power up	Wiring terminals for power at transformer and controller
	Supply voltage (see Appendix E - Technical Specifications)
Superheat below setpoint	Pressure Transducer Range (correct transducer set up in controller; 0-300, etc)
	Pressure Transducer Type (correct transducer set up in controller; gauge/sealed vs absolute)
	Temperature Sensor Type (correct sensor set up in controller; see Appendix I - Sensor Installation)
	Temperature Sensor wiring (ensure sensor locations are not mismatched)
	Foam insulation on piping and sensors
Superheat above setpoint	Liquid condition entering expansion valve
	Pressure Transducer Range (correct transducer set up in controller; 0-300, etc)
	Temperature Sensor Type (correct sensor set up in controller; see Appendix I - Sensor Installation)
	EEV (correct valve set up in controller; 1596, 2500 steps, etc)
	EEV sizing (if EEV position in controller is at 100% when symptom exists, EEV may be undersized)
	Heat exchanger sizing
	Proper system refrigerant charge
	Oil return (oil logging in heat exchanger)
	Liquid line filter (clogging or excessive pressure drop)
No Superheat	Wiring terminals (power) at transformer and controller
	Proper system refrigerant charge
	Pressure Transducer Range (correct transducer set up in controller; 0-300, etc)
	Pressure Transducer Type (correct transducer set up in controller; gauge/sealed vs absolute)
	Temperature Sensor Type (correct sensor set up in controller; see Appendix I - Sensor Installation)
	Temperature Sensor wiring (ensure sensor locations are not mismatched)
	Foam insulation on piping and sensors
Superheat unstable	Wiring terminals (power) at transformer and controller
	Wiring terminals (sensors) at controller
	Sensor locations
	Sensor operation (See additional information under Section 8 - Troubleshooting)
	Proper heat exchanger flow direction
	Stability of head pressure control valves (upstream of EEV)
	Stability of suction pressure control valves (downstream of EEV)
	Stability of rack controller (verify compressors are not short cycling)
	Controller PID setting (See Section 7 - PID Tuning)
No Communication	Wiring at controller and master communication board
	Addresses of controllers (see Section 6 - Controller Networking)
Communication errors	Wiring terminals at controller and master communication board
	Network wiring from controller to master communication board (see Section 6 - Controller Networking)
	Proper network wire grounding (see Section 6 - Controller Networking)
	Termination resistors (see Section 6 - Controller Networking)
	Network parameters in controller and master communication board (baud rate, parity, etc; see Section 6)
	Third-party controllers on Control network
Setpoints not saved	ESC must be set within 60 seconds of changes being made

Table 4 - Alarm Actions

ALARM	DESCRIPTION	CAUSE	SYSTEM ACTION
<i>PSAL</i>	Pressure Sensor Alarm	<ol style="list-style-type: none"> Voltage across terminals 33 and 34 less than 0.3VDC Voltage across terminals 33 and 34 greater than 4.6VDC (System pressure greater than operating range of transducer, set by <i>P-rng</i>) Note: If <i>HPR</i> is set to <i>oFF</i> , then <i>PSAL</i> for high pressure will not activate.	Opens terminals 19 and 20 and closes EEV (pumpdown) until proper pressure input returns. Alarm is generated and a voltage difference will occur across terminals 11/12 (for use with an external alarm relay)
<i>tSAL</i>	<i>tout</i> Temperature Sensor Alarm	Voltage across terminals 31 and 32 is outside of the normal range of the thermistor. Normal ranges: 2K = 0.36VDC to 4.5VDC 3K = 0.39VDC to 4.9VDC 10K = 0.3VDC to 4.6VDC 98.6K = 0.36VDC to 4.8VDC Note: Display will show <i>-60</i> if temperature sensor is not installed.	Opens terminals 19 and 20 and closes EEV (pumpdown) until proper temperature input returns. Alarm is generated and a voltage difference will occur across terminals 11/12 (for use with an external alarm relay)
<i>L5HA</i>	Low Superheat Alarm	System operates less than 2°F superheat for the delay time set by <i>L5hd</i> .	Will use <i>L5Hl</i> parameter to close the EEV quicker. Alarm is generated and a voltage difference will occur across terminals 11/12 (for use with an external alarm relay). Normal operation will resume and alarm will clear once system superheat reaches 2°F.
<i>H5HA</i>	High Superheat Alarm	System operates more than 2°F above <i>H5SP</i> (setpoint) for the delay time set by <i>H5hd</i> .	If <i>h5HF</i> is set to <i>oFF</i> : No system response. Alarm is generated and a voltage difference will occur across terminals 11/12 (for use with an external alarm relay). If <i>h5HF</i> is set to <i>on</i> : EEV drives to 0% position. Alarm is generated and a voltage difference will occur across terminals 11/12. Note: A power cycle is required to resume normal operation if <i>h5HF</i> is set to 'on' and the system goes into high superheat alarm.

APPENDIX A - Setup Menu

DISPLAY	DESCRIPTION	OPTIONS																																																																						
5EEP	Valve Type	<table border="1"> <thead> <tr> <th>Display Readout</th> <th>Description</th> </tr> </thead> <tbody> <tr><td>1596</td><td>1596 Step Bipolar Valve</td></tr> <tr><td>3193</td><td>3193 Step Bipolar Valve</td></tr> <tr><td>2500</td><td>2500 Step Bipolar Valve</td></tr> <tr><td>6386</td><td>6386 Step Bipolar Valve</td></tr> <tr><td>500</td><td>500 Step Unipolar Valve</td></tr> </tbody> </table>	Display Readout	Description	1596	1596 Step Bipolar Valve	3193	3193 Step Bipolar Valve	2500	2500 Step Bipolar Valve	6386	6386 Step Bipolar Valve	500	500 Step Unipolar Valve																																																										
Display Readout	Description																																																																							
1596	1596 Step Bipolar Valve																																																																							
3193	3193 Step Bipolar Valve																																																																							
2500	2500 Step Bipolar Valve																																																																							
6386	6386 Step Bipolar Valve																																																																							
500	500 Step Unipolar Valve																																																																							
rEFr	Refrigerant Type NOTE: Select the actual refrigerant used in the system.	<table border="1"> <thead> <tr> <th>Display Readout</th> <th>Description</th> </tr> </thead> <tbody> <tr><td>r22</td><td>R-22</td></tr> <tr><td>134A</td><td>R-134a</td></tr> <tr><td>402A</td><td>R-402A</td></tr> <tr><td>404A</td><td>R-404A</td></tr> <tr><td>407A</td><td>R-407A</td></tr> <tr><td>407C</td><td>R-407C</td></tr> <tr><td>410A</td><td>R-410A</td></tr> <tr><td>417A</td><td>R-417A</td></tr> <tr><td>422A</td><td>R-422A</td></tr> <tr><td>422d</td><td>R-422D</td></tr> <tr><td>r507</td><td>R-507A</td></tr> <tr><td>r744</td><td>R-744</td></tr> <tr><td>245F</td><td>R-245FA</td></tr> <tr><td>r-E5</td><td>R-E5</td></tr> <tr><td>438A</td><td>R-438A</td></tr> <tr><td>401b</td><td>R-401B</td></tr> <tr><td>408A</td><td>R-408A</td></tr> <tr><td>508A</td><td>R-508A</td></tr> <tr><td>508b</td><td>R-508B</td></tr> <tr><td>407F</td><td>R-407F</td></tr> <tr><td>434A</td><td>R-434A</td></tr> <tr><td>444b</td><td>R-444B</td></tr> <tr><td>448A</td><td>R-448A</td></tr> <tr><td>450A</td><td>R-450A</td></tr> <tr><td>449A</td><td>R-449A</td></tr> <tr><td>452A</td><td>R-452A</td></tr> <tr><td>513A</td><td>R-513A</td></tr> <tr><td>dr2</td><td>R-DR2 (R-1336MZZ)</td></tr> <tr><td>r32</td><td>R-32</td></tr> <tr><td>452b</td><td>R-452B</td></tr> <tr><td>1234</td><td>R-1234ZE</td></tr> <tr><td>124</td><td>R-124</td></tr> <tr><td>458A</td><td>R-458A</td></tr> <tr><td>453A</td><td>R-453A</td></tr> </tbody> </table>	Display Readout	Description	r22	R-22	134A	R-134a	402A	R-402A	404A	R-404A	407A	R-407A	407C	R-407C	410A	R-410A	417A	R-417A	422A	R-422A	422d	R-422D	r507	R-507A	r744	R-744	245F	R-245FA	r-E5	R-E5	438A	R-438A	401b	R-401B	408A	R-408A	508A	R-508A	508b	R-508B	407F	R-407F	434A	R-434A	444b	R-444B	448A	R-448A	450A	R-450A	449A	R-449A	452A	R-452A	513A	R-513A	dr2	R-DR2 (R-1336MZZ)	r32	R-32	452b	R-452B	1234	R-1234ZE	124	R-124	458A	R-458A	453A	R-453A
Display Readout	Description																																																																							
r22	R-22																																																																							
134A	R-134a																																																																							
402A	R-402A																																																																							
404A	R-404A																																																																							
407A	R-407A																																																																							
407C	R-407C																																																																							
410A	R-410A																																																																							
417A	R-417A																																																																							
422A	R-422A																																																																							
422d	R-422D																																																																							
r507	R-507A																																																																							
r744	R-744																																																																							
245F	R-245FA																																																																							
r-E5	R-E5																																																																							
438A	R-438A																																																																							
401b	R-401B																																																																							
408A	R-408A																																																																							
508A	R-508A																																																																							
508b	R-508B																																																																							
407F	R-407F																																																																							
434A	R-434A																																																																							
444b	R-444B																																																																							
448A	R-448A																																																																							
450A	R-450A																																																																							
449A	R-449A																																																																							
452A	R-452A																																																																							
513A	R-513A																																																																							
dr2	R-DR2 (R-1336MZZ)																																																																							
r32	R-32																																																																							
452b	R-452B																																																																							
1234	R-1234ZE																																																																							
124	R-124																																																																							
458A	R-458A																																																																							
453A	R-453A																																																																							
EE4P	Temperature Sensor Type	<table border="1"> <thead> <tr> <th>Readout</th> <th>Description</th> </tr> </thead> <tbody> <tr><td>EP3</td><td>3K Thermistor</td></tr> <tr><td>EP2</td><td>2K Thermistor</td></tr> <tr><td>EP98</td><td>98.6K Thermistor</td></tr> <tr><td>EP10</td><td>10K Thermistor</td></tr> </tbody> </table>	Readout	Description	EP3	3K Thermistor	EP2	2K Thermistor	EP98	98.6K Thermistor	EP10	10K Thermistor																																																												
Readout	Description																																																																							
EP3	3K Thermistor																																																																							
EP2	2K Thermistor																																																																							
EP98	98.6K Thermistor																																																																							
EP10	10K Thermistor																																																																							
PE4P	Pressure Sensor Type	<table border="1"> <thead> <tr> <th>Display Readout</th> <th>Description</th> </tr> </thead> <tbody> <tr><td>AbSL</td><td>Absolute Pressure Type</td></tr> <tr><td>9AUG</td><td>Gauge (Sealed) Pressure Type</td></tr> </tbody> </table>	Display Readout	Description	AbSL	Absolute Pressure Type	9AUG	Gauge (Sealed) Pressure Type																																																																
Display Readout	Description																																																																							
AbSL	Absolute Pressure Type																																																																							
9AUG	Gauge (Sealed) Pressure Type																																																																							
Un_t	Temperature Units	<table border="1"> <thead> <tr> <th>Display Readout</th> <th>Description</th> </tr> </thead> <tbody> <tr><td>FAHr</td><td>Fahrenheit</td></tr> <tr><td>CELS</td><td>Celsius</td></tr> </tbody> </table>	Display Readout	Description	FAHr	Fahrenheit	CELS	Celsius																																																																
Display Readout	Description																																																																							
FAHr	Fahrenheit																																																																							
CELS	Celsius																																																																							
Un_P	Pressure Units	<table border="1"> <thead> <tr> <th>Display Readout</th> <th>Description</th> </tr> </thead> <tbody> <tr><td>PSI</td><td>Pounds per square inch</td></tr> <tr><td>bAr</td><td>Bar units</td></tr> </tbody> </table>	Display Readout	Description	PSI	Pounds per square inch	bAr	Bar units																																																																
Display Readout	Description																																																																							
PSI	Pounds per square inch																																																																							
bAr	Bar units																																																																							

Counterclockwise

Clockwise

Default values are highlighted.

APPENDIX B - Process Values

PROCESS	DESCRIPTION	RANGE												
<i>End</i>	End display session with controller	Controller display address <i>CAdr</i> must be reset *												
<i>SuPH</i>	Superheat ($t_{out}-t_{sat}$)	0 to 165°F (0 to 91.6°C)												
<i>SucP</i>	Suction Pressure	Depends on pressure sensor range and type -14.7 to 652 PSI (-1.01 to 44.95 Bar) Max. range												
<i>tSAE</i>	Saturation Temperature	-60 to 150°F (-51.1 to 65.6°C)												
<i>tout</i>	Suction Temperature	-60 to 150°F (-51.1 to 65.6°C)												
<i>CtP</i>	Case / Room Temperature	-60 to 150°F (-51.1 to 65.6°C)												
<i>Posn</i>	EEV Position (% of max stroke)	0 to 100% Open												
<i>S-3</i>	Auxiliary Temperature 1 or Pumpdown State	-60 to 150°F (-51.1 to 65.6°C) if input is within range for a valid temperature reading. Otherwise: <table border="1"> <thead> <tr> <th>Display</th> <th>Description</th> </tr> </thead> <tbody> <tr> <td><i>Cool</i></td> <td>Cool Mode - High Resistance or open on T3</td> </tr> <tr> <td><i>Pdn</i></td> <td>Pumpdown Mode - Low Resistance or short on T3</td> </tr> </tbody> </table>	Display	Description	<i>Cool</i>	Cool Mode - High Resistance or open on T3	<i>Pdn</i>	Pumpdown Mode - Low Resistance or short on T3						
Display	Description													
<i>Cool</i>	Cool Mode - High Resistance or open on T3													
<i>Pdn</i>	Pumpdown Mode - Low Resistance or short on T3													
<i>S-4</i>	Auxiliary Temperature 2	-60 to 150°F (-51.1 to 65.6°C)												
<i>rELR</i>	Relay Status	<table border="1"> <thead> <tr> <th>Display</th> <th>Description</th> </tr> </thead> <tbody> <tr> <td><i>dEn9</i></td> <td>Relay is de-energized (open)</td> </tr> <tr> <td><i>En9</i></td> <td>Relay is energized (closed)</td> </tr> </tbody> </table>	Display	Description	<i>dEn9</i>	Relay is de-energized (open)	<i>En9</i>	Relay is energized (closed)						
Display	Description													
<i>dEn9</i>	Relay is de-energized (open)													
<i>En9</i>	Relay is energized (closed)													
<i>StAt</i>	System State	<table border="1"> <thead> <tr> <th>Display</th> <th>Description</th> </tr> </thead> <tbody> <tr> <td><i>SEtU</i></td> <td>Setup Mode</td> </tr> <tr> <td><i>OFF</i></td> <td>Off Mode</td> </tr> <tr> <td><i>COOL</i></td> <td>Cool Mode</td> </tr> <tr> <td><i>Pdn</i></td> <td>Pumpdown Mode</td> </tr> <tr> <td><i>StPO</i></td> <td>Manual Valve Override Mode</td> </tr> </tbody> </table>	Display	Description	<i>SEtU</i>	Setup Mode	<i>OFF</i>	Off Mode	<i>COOL</i>	Cool Mode	<i>Pdn</i>	Pumpdown Mode	<i>StPO</i>	Manual Valve Override Mode
Display	Description													
<i>SEtU</i>	Setup Mode													
<i>OFF</i>	Off Mode													
<i>COOL</i>	Cool Mode													
<i>Pdn</i>	Pumpdown Mode													
<i>StPO</i>	Manual Valve Override Mode													
<i>ALS</i>	Controller Alarms	<table border="1"> <thead> <tr> <th>Display</th> <th>Description</th> </tr> </thead> <tbody> <tr> <td><i>nonE</i></td> <td>No Active Alarms</td> </tr> <tr> <td><i>PSAL</i></td> <td>Pressure Sensor Failure</td> </tr> <tr> <td><i>tSAL</i></td> <td>Suction Temp Sensor Failure</td> </tr> <tr> <td><i>LSHA</i></td> <td>Low Superheat Alarm</td> </tr> <tr> <td><i>HSHA</i></td> <td>High Superheat Alarm</td> </tr> </tbody> </table>	Display	Description	<i>nonE</i>	No Active Alarms	<i>PSAL</i>	Pressure Sensor Failure	<i>tSAL</i>	Suction Temp Sensor Failure	<i>LSHA</i>	Low Superheat Alarm	<i>HSHA</i>	High Superheat Alarm
Display	Description													
<i>nonE</i>	No Active Alarms													
<i>PSAL</i>	Pressure Sensor Failure													
<i>tSAL</i>	Suction Temp Sensor Failure													
<i>LSHA</i>	Low Superheat Alarm													
<i>HSHA</i>	High Superheat Alarm													

NOTE: The controller's default menu is the Process Values Menu.

*If the controller display is alternating between *Ct-L*, and either a number 1-99 or *LocL*, then scroll to *LocL* and press the SELECT knob to view the local controller attached to this display. Press and hold the SELECT knob for approximately 5 seconds and enter password *!!!* when prompted. Scroll to *CAdr* (Controller address) and set it to 0. Exit the setpoint menu.

APPENDIX C - Setpoint Parameters

PARAMETERS			
	<i>ESC</i>	Escape and save settings	-
	<i>SHSP</i>	Superheat Setpoint Change to desired Superheat Setpoint	5 to 45°F (2.7 to 25°C) Default is 10°F (5.5°C)
Counter-clockwise	<i>rEFr</i> Chosen at Setup	Refrigerant Type Change to desired Refrigerant Type	<i>r22</i> R-22
			<i>134A</i> R-134a
			<i>402A</i> R-402A
			404A R-404A
			<i>407A</i> R-407A
			<i>407C</i> R-407C
			<i>410A</i> R-410A
			<i>417A</i> R-417A
			<i>422A</i> R-422A
			<i>422d</i> R-422D
			<i>r507</i> R-507A
			<i>r744</i> R-744
			<i>245F</i> R-245FA
			<i>r-E5</i> R-E5
			<i>438A</i> R-438A
			<i>401b</i> R-401B
			<i>408A</i> R-408A
			<i>508A</i> R-508A
			<i>508b</i> R-508B
			<i>407F</i> R-407F
<i>434A</i> R-434A			
<i>444b</i> R-444B			
<i>448A</i> R-448A			
<i>450A</i> R-450A			
<i>449A</i> R-449A			
<i>452A</i> R-452A			
<i>513A</i> R-513A			
<i>dr2</i> R-DR2 (R-1336MZZ)			
<i>r32</i> R-32			
<i>452b</i> R-452B			
<i>1234</i> R-1234ZE			
<i>124</i> R-124			
<i>458A</i> R-458A			
<i>453A</i> R-453A			
	<i>d_on</i>	Delay On	0 to 60 seconds Default is 0
	<i>dOFF</i>	Delay Off	0 to 60 seconds Default is 0
	<i>d_St</i>	Delay Step Position Open of Valve	0 to 100% Default is 0%
	<i>b_St</i>	Bleed Step Position of Valve %	0 to 15.0% Default is 0.0%
	<i>b_dL</i>	Bleed Delay Time	0 to 9999 seconds Default is 0
	<i>L_oP</i>	Low Operating Pressure	Values depend on pressure sensor range and type. Set <i>Prrn9</i> first, then EXIT, then set this value. -14.7 to 485 psi (-1.03 to 9.30 Bar) max.range
	<i>H_oP</i>	Maximum Operating Pressure	Values depend on pressure sensor range and type. Set <i>Prrn9</i> first, then EXIT, then set this value. 5 to 652 psi (1.37 to 44.95 Bar) max. range
	<i>E_in</i>	Cut-in Temperature	-59 to 125°F (-50.5 to 51.6°C) Default is -59 (-50.5 C)
	<i>E_out</i>	Cut-out Temperature	-60 to 124°F (-51.1 to 51.0°C) Default is -60 (-51.1 C)
	<i>r_onT</i>	Minimum Relay OnTime	0 to 10 Default is 0
	<i>r_ofT</i>	Minimum Relay OffTime	0 to 10 Default is 0
	<i>H_iCP</i>	Max Valve Capacity	0 to 100% Default is 100
	<i>SUPS</i>	Supermarket Mode	ON or OFF Default is ON
	<i>dbnd</i>	Superheat Control Deadband	1 (+/-1°F) or 2 (+/-2°F) Default is 2

Default values are highlighted.

APPENDIX C - Setpoint Parameters (continued)

PARAMETERS		SUPS ON	SUPS OFF
-P-	Proportional Coefficient	0 to 18 Default is 6	0 to 50 Default is 6
-I-	Integral Coefficient	0 to 24 Default is 12	0 to 100 Default is 12
-d-	Derivative Coefficient	0 to 4 Default is 1	0 to 50 Default is 1
LSH i	Low Superheat Integral	1 to 100 Default is 25	
StEP Chosen at Setup	Valve Type	1596 3193 2500 6386 500	1596 Step Bipolar Valve 3193 Step Bipolar Valve 2500 Step Bipolar Valve 6386 Step Bipolar Valve 500 Step Unipolar Valve
SPoS	Manual Valve Position	0 to 100% Open Default is current valve position	
nEt	Network Type	nbUS (Modbus) or bACn (BACnet)	
Addr	Network Address	1 to 255 Default is 1	
bAud	Baud Rate	96 192 384	9600 19200 38400
nPAR	Network Parity	nonE EuEn odd	No Parity Even Parity Odd Parity
Un_P	Pressure Units	PS i bAr	Pounds Force Per Square Inch Bars
Un_t	Temperature Units	FAHr CEL5	Fahrenheit Celsius
Et4P Chosen at Setup	Temperature Sensor Type	Readout Et4P3 Et4P2 Et4P8 Et4P10	Description 3K thermistor 2K thermistor 98.6K thermistor 10K thermistor
Pt4P Chosen at Setup	Pressure Sensor Type	Ab5L 9AUS	Absolute Pressure Type Gauge (Sealed) Pressure Type
Prr9	Pressure Sensor Range	Rubo 150 300 500 652	Based on Refrigerant 0-150 psi 0-300 psi 0-500 psi 0-652 psi
CLLP	Pressure Sensor Calibration Offset	-5 to 5 psi (-.34 to .34 Bar) Default is 0 psi (0.00 Bar)	
CLt1	Suction Temperature Calibration Offset	-5 to 5°F (-2.7 to 2.7°C) Default is 0	
CLt2	T2 / Room Temperature Calibration Offset	-5 to 5°F (-2.7 to 2.7°C) Default is 0	
CLt3	T3 Temperature Calibration Offset	-5 to 5°F (-2.7 to 2.7°C) Default is 0	
CLt4	T4 Temperature Calibration Offset	-5 to 5°F (-2.7 to 2.7°C) Default is 0	
hPR	High Pressure Alarm	On or Off Default is On	
hSHF	High Superheat Failsafe	On or Off Default is Off	
Stto	Manual Stepper Timeout Override	On or Off Default is Off	
LShd	Low Superheat Alarm Delay	30 to 3600 seconds Default is 30	
hShd	High Superheat Alarm Delay	1 to 240 minutes Default is 60	
CLdr	Controller Display Address	0 to 99 Default is 0 for display, 2 for w/o display	

Default values are highlighted.

APPENDIX D - Accessories

DESCRIPTION	ITEM NUMBER	NOTES
Superheat Controls Superheat Control with Display Superheat Control without Display Kelvin IId	952567 952569 952568	Standalone Controller with display Standalone Controller, no display Remote display unit
Power Supply	953444	Kelvin power supply 100-240 VAC/24VDC
Parker Sporlan Temperature Probes 2K Sensor 3K Surface Sensor (black) 3K Air Sensor (black) 10K Surface Sensor (orange) 10K Surface Sensor (blue) 10K Surface Sensor (red) 10K Air Sensor (green) 98.6K Surface Sensor (white)	952662 230545 230546 230072 230076 230078 230073 952565	Used with or without well 20 ft. Surface only 20 ft. Air only 20 ft. Surface only 20 ft. Surface only 20 ft. Surface only 20 ft. Air only Surface only
Parker Sporlan Pressure Transducers* PSPT0150SVSP-S PSPT0300SVSP-S PSPT0500SVSP-S PSPT0652SVSP-S	952572 952574 952576 952579	0-150 psis transducer (all other refrigerants) 0-300 psis transducer (R410A) 0-500 psis transducer (R744) 0-652 psis transducer (R744)
Transducer Cables PSPT000000CP50 PSPT000000CP20	953100 953192	5 meter (16 ft.) cable 2 meter (6.5 ft.) cable
Troubleshooting Accessories SMA-12	953276	Handheld digital instrument for testing EEV performance.

*Select one per controller based on refrigerant.

APPENDIX E - Technical Specifications

<p>ELECTRICAL</p> <p>Supply Voltage 20-26VAC 50/60Hz or 22-26.6VDC; Class II input. 40VA is recommended for each controller</p> <p>Digital Inputs 0-5VDC Maximum Range Interface to dry contact or open collector</p> <p>Analog Inputs 4 Temperature Sensors; 2K, 3K, 10K or 98.6K Ohm 1 Pressure Transducer .5 - 4.5VR</p> <p>Relay Outputs 100-240VAC, 3A ind/250V 22-28VDC, 250mA digital output (For Alarm Relay)</p> <p>Digital Display LED - Red, 7 segment, 4 digit</p> <p>Indicators LED - Red, Power</p> <p>User Interface Optical Encoder (SELECT knob)</p> <p>Data Interface RS 485, Modbus, BACnet</p>	<p>MECHANICAL</p> <p>Operating Temperature -40°F to 158°F (-40°C to 70°C)</p> <p>Humidity 0-95%RH (Non-Condensing)</p> <p>Enclosure PC - Light Gray</p> <p>Wiring Screw terminal</p> <p>Mounting DIN Rail - EN 50 022</p> <p>COMPLIANCE</p> <p>Environmental RoHS WEEE</p> <p>Electrical CE UL/CUL (Recognized per 873) FCC (Class A, part 15) C-tick</p>
---	--

APPENDIX F - Controller Status

DISPLAY	DESCRIPTION
<i>Cool</i>	Compressor running
<i>Pdn</i>	Superheat Control Off (Pumpdown)
<i>OFF</i>	Compressor not running

APPENDIX G - Miscellaneous Displays

DISPLAY	DESCRIPTION
<i>End</i>	Press SELECT knob to exit menu
<i>bAd</i>	The wrong password has been entered
<i>LoCL</i>	Shows that readings refer to current controller
<i>Ctrl</i>	Shows which controller is displayed

APPENDIX H - Wiring Diagram

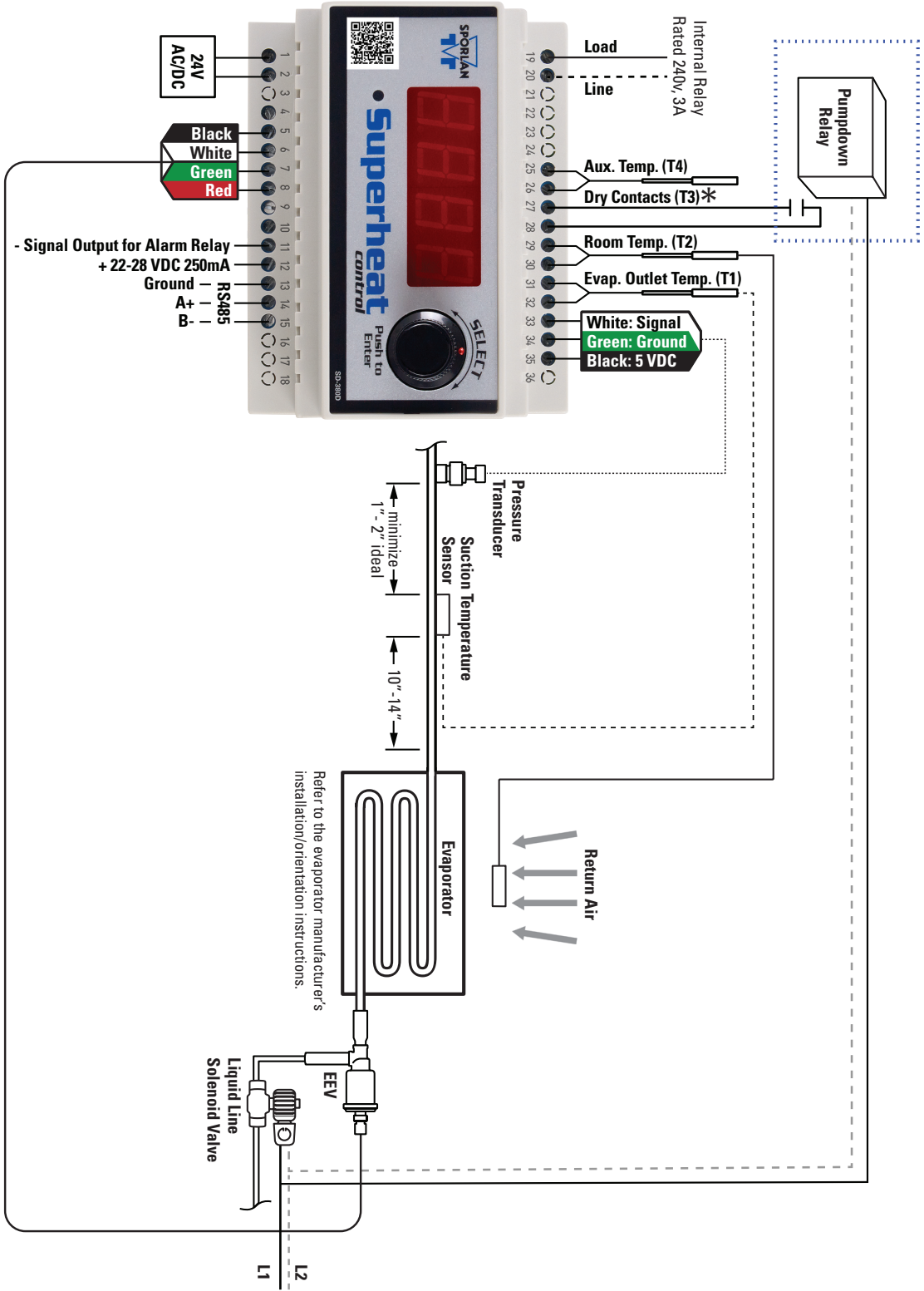

*T3 can be used as an Auxiliary Temperature Input or a Pumpdown Input signal.
 Note: Piping and sensor insulation is not shown.

For 500 Step Sporlan Unipolar Valve

- 4 -> Gray Wire
- 5 -> Orange Wire
- 6 -> Yellow Wire
- 7 -> Red Wire
- 8 -> Black Wire



Note: Use caution when working around high voltage components.

APPENDIX I - Sensor Installation

Refer to *Appendix H - Wiring Diagram* for sensor locations.

Mount the Pressure Transducer

1. Locate or install a ¼" SAE access fitting on the suction line near the outlet of the evaporator. Mount it at 12 o'clock on a free-draining horizontal line to decrease the possibility of oil trapping.



WARNING: Remove pressurized refrigerant from the line before installing the fitting.

2. Install the transducer, tighten it to 8 ft-lbs, and check for leaks. Do not use a gasket or a washer.

WARNING: For safety, ensure that the correct Schrader core is installed in the access fitting and use caution when removing Schrader cap/installing transducer to avoid contacting escaping refrigerant.

3. Connect the pressure transducer cable to the transducer.
4. Route and secure transducer cable away from hot surfaces and high power A/C voltage lines.
5. Connect transducer wires to the Superheat Control.
6. Ensure pressure range and type (gauge or absolute) are configured properly in the Superheat Control, See *Section 2 - SETUP*.
7. After startup, use a gauge set to verify proper pressure reading through the controller. An improperly installed Schrader core can cause erroneous pressure readings.
8. Check for leaks after system is in operation.

Mount the Suction Outlet Temperature Sensor

1. Per *Appendix H - Wiring Diagram*, the temperature sensor should be installed 10-14 inches from the heat exchanger, on a free-draining horizontal line. Minimize the distance from the pressure transducer.
2. Use Scotch-Brite™ to clean the copper line at the installation location. Remove oxides and dirt to increase sensor accuracy.
3. Fasten the suction temperature sensor as oriented in *Figure 8*. Mount the sensor on the suction line after the heat exchanger, near the pressure transducer.
4. Route the cable away from hot surfaces and high power A/C voltage lines.
5. Connect sensor wires to the Superheat Control.
6. Verify that the Superheat Control is configured properly for the temperature sensor used (2K, 3K, etc.), See *Section 2 - SETUP*.
7. Wrap temperature sensor and copper tube with foam insulation to minimize ambient temperature effects (*Figure 9*).

Mount the Optional Room Temperature Sensor

1. Mount the Room or Box temperature sensor in the area to be controlled. Ensure that it is at least 4 inches from the surface of the evaporator coil.
2. Connect sensor wires to terminals 29 and 30 on the Superheat Control as shown in *Appendix H - Wiring Diagram*. The sensor leads are not polarized.
3. Ensure that the Superheat Control is configured properly for the temperature sensor used (2K, 3K, etc.), See *Section 2 - SETUP*.

Figure 8 - Temperature Sensor Positioning

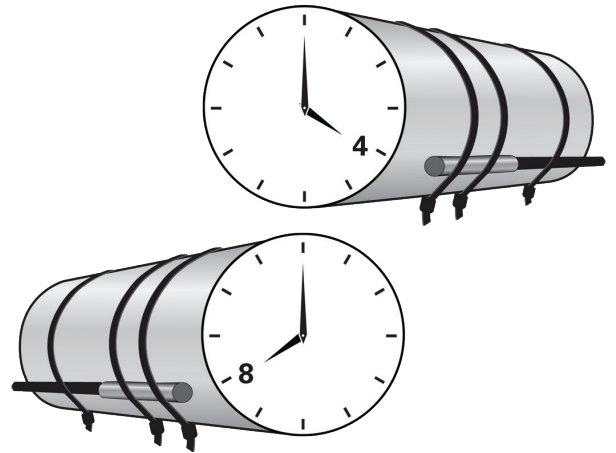

Temperature sensor should be mounted at either 4 or 8 o'clock, on a free-draining horizontal line.

Figure 9 - Cutaway of Pipe Insulation



2K sensor shown

NOTE: Sensors may be extended to 100 ft. (30.5 m) using 18 gauge shielded twisted pair cable. Splice connections should use Scotchlok™ UR connectors for long-term integrity. The pressure transducer cable can be extended with Belden 9493 or equivalent and temperature sensors can be extended with Belden 9409 or equivalent



WARNING: Route and secure sensor cables away from hot surfaces, high voltage lines, and moving components.

APPENDIX J - Modbus Memory Map

FUNCTION (FUNCTION CODE)	REGISTER ADDRESS/DESCRIPTION	RANGE																																		
Read Coils (0x01)	0. Manual Valve Enabled Flag	0 = Disabled 1 = Enabled																																		
	1. Manual Valve Duration Enabled Flag	0 = Disabled 1 = Enabled																																		
	2. Stepper Timeout Override Enable	0 = Disabled 1 = Enabled																																		
Read Holding Register (0x03)	0. Superheat Setpoint	5 to 45°F (2.7 to 25.0°C)																																		
	1. Refrigerant Type	<table border="0"> <tr> <td>0 = R-22</td> <td>17 = R-508A</td> </tr> <tr> <td>1 = R-134A</td> <td>18 = R-508B</td> </tr> <tr> <td>2 = R-402A</td> <td>19 = R-407F</td> </tr> <tr> <td>3 = R-404A</td> <td>20 = R-434A</td> </tr> <tr> <td>4 = R-407A</td> <td>21 = R-444B</td> </tr> <tr> <td>5 = R-407C</td> <td>22 = R-448A</td> </tr> <tr> <td>6 = R-410A</td> <td>23 = R-450A</td> </tr> <tr> <td>7 = R-417A</td> <td>24 = R-449A</td> </tr> <tr> <td>8 = R-422A</td> <td>25 = R-452A</td> </tr> <tr> <td>9 = R-422D</td> <td>26 = R-513A</td> </tr> <tr> <td>10 = R-507A</td> <td>27 = R-DR2 (R-1336MZZ)</td> </tr> <tr> <td>11 = R-744</td> <td>28 = R-32</td> </tr> <tr> <td>12 = R-245FA</td> <td>29 = R-452B</td> </tr> <tr> <td>13 = R-E5</td> <td>30 = R-1234ZE</td> </tr> <tr> <td>14 = R-438A</td> <td>31 = R-124</td> </tr> <tr> <td>15 = R-401B</td> <td>32 = R-458A</td> </tr> <tr> <td>16 = R-408A</td> <td>33 = R-453A</td> </tr> </table>	0 = R-22	17 = R-508A	1 = R-134A	18 = R-508B	2 = R-402A	19 = R-407F	3 = R-404A	20 = R-434A	4 = R-407A	21 = R-444B	5 = R-407C	22 = R-448A	6 = R-410A	23 = R-450A	7 = R-417A	24 = R-449A	8 = R-422A	25 = R-452A	9 = R-422D	26 = R-513A	10 = R-507A	27 = R-DR2 (R-1336MZZ)	11 = R-744	28 = R-32	12 = R-245FA	29 = R-452B	13 = R-E5	30 = R-1234ZE	14 = R-438A	31 = R-124	15 = R-401B	32 = R-458A	16 = R-408A	33 = R-453A
	0 = R-22	17 = R-508A																																		
	1 = R-134A	18 = R-508B																																		
	2 = R-402A	19 = R-407F																																		
	3 = R-404A	20 = R-434A																																		
	4 = R-407A	21 = R-444B																																		
	5 = R-407C	22 = R-448A																																		
	6 = R-410A	23 = R-450A																																		
	7 = R-417A	24 = R-449A																																		
	8 = R-422A	25 = R-452A																																		
	9 = R-422D	26 = R-513A																																		
	10 = R-507A	27 = R-DR2 (R-1336MZZ)																																		
	11 = R-744	28 = R-32																																		
	12 = R-245FA	29 = R-452B																																		
	13 = R-E5	30 = R-1234ZE																																		
	14 = R-438A	31 = R-124																																		
	15 = R-401B	32 = R-458A																																		
	16 = R-408A	33 = R-453A																																		
2. Delay On Relay	0 to 60 seconds																																			
3. Delay Off Relay	0 to 60 seconds																																			
4. Delay Steps	0 to 100% open																																			
5. Low Operating Pressure	0 to 150 psi (0 to 13.34 Bar)																																			
6. Maximum Operating Pressure	0 to 150 psi (0 to 13.34 Bar)																																			
7. Temperature Cut-in	-60 to 125°F (-51 to 51.7°C)																																			
8. Temperature Cut-out	-60 to 125°F (-51 to 51.7°C)																																			
9. Valve Maximum	0 to 100%																																			
10. Supermarket Mode	1=On, 0=Off																																			
11. Proportional Coefficient	0 to 18 if Supermarket Mode is On 0 to 50 if Supermarket Mode is Off																																			
12. Integral Coefficient	0 to 24 if Supermarket Mode is On 0 to 100 if Supermarket Mode is Off																																			
13. Derivative Coefficient	0 to 4 if Supermarket Mode is On 0 to 50 if Supermarket Mode is Off																																			
14. Valve Type	0 = 1596 1 = 3193 2 = 2500 3 = 6386 4 = 500																																			
15. Manual Valve Position	0 to 100.0% Open																																			
16. Network Address	1 to 255																																			
17. Pressure Units	0 = PSI 1 = BAR																																			
18. Temperature Units	0 = FAHR 1 = CELS																																			
19. Pressure Sensor Type	0 = ABSL 1 = GauG																																			

APPENDIX J - Modbus Memory Map (continued)

FUNCTION (FUNCTION CODE)	REGISTER ADDRESS/DESCRIPTION	RANGE
Read Holding Register (0x03)	20. Pressure Calibration Offset	-5 to 5 PSI (-0.34 to 0.34 Bar)
	21. Suction Temperature Calibration Offset (T1)	-5 to 5°F (-2.8 to 2.8°C)
	22. Room Temperature Calibration Offset (T2)	-5 to 5°F (-2.8 to 2.8°C)
	23. Auxiliary Temperature 1 Calibration Offset (T3)	-5 to 5°F (-2.8 to 2.8°C)
	24. Pressure Range	0 = Auto (based of refrigerant) 1 = 150 PSI 2 = 300 PSI 3 = 500 PSI 4 = 652 PSI
	25. Bleed Port Percent Open of Valve	0 to 150 (0 to 15 percent)
	26. Bleed Delay Time	0 to 9999 seconds
	27. Controller Display Address	0 to 99
	28. Temperature Sensor Type	0 = 3K thermistor 1 = 2K thermistor 2 = 98.6K thermistor 3 = 10K thermistor
	29. Auxillary Temp 2 Calibration Offset (T4)	-5 to 5°F (-2.8 to 2.8°C)
	30. Superheat Control Deadband	1 or 2°F (.6 or 1.1°C)
	31. Minimum Relay On Time	0 to 10 minutes
	32. Minimum Relay Off Time	0 to 10 minutes
	33. High Pressure Alarm Enable	0 = Disabled 1 = Enabled
	34. Low Superheat Integral	1 to 100
	35. High Superheat Failsafe Enable	(0 = disabled, 1 = enabled)
	36. Low Superheat Alarm Delay	(30 to 3600 seconds)
37. High Superheat Alarm Delay	(1 to 240 minutes)	
Read Input Registers (0x04)	0. Superheat	0 to 165°F (0 to 91.6°C)
	1. Suction Pressure	Depends on Pressure Sensor Range and Type -15 to 500 PSI (-1.01 to 34.47 Bar) Maximum Range
	2. Saturation Temperature	-60 to 150°F (-51.1 to 65.6°C)
	3. Suction Temperature	-60 to 150°F (-51.1 to 65.6°C)
	4. Room Temperature	-60 to 150°F (-51.1 to 65.6°C)
	5. Valve Position (% of Max. Stroke)	0 to 100.0% Open
	6. Auxiliary Temperature 1	-60 to 150°F (-51.1 to 65.6°C)
	7. Relay Status	0 = de-energized, 1 = energized
	8. Alarm Status	If Bit set then alarm is active: Bit 0 = Pressure Sensor Failure Alarm Bit 1 = Suction Temperature Sensor Failure Alarm Bit 2 = Low Superheat Alarm Bit 3 = High Superheat Alarm
	9. System State	If Bit set then mode is active: Bit 1 = Setup Mode Bit 2 = Off Cycle Bit 3 = Cooling Cycle Bit 4 = Pump-down Cycle Bit 5 = Manual Valve Override Mode
	10. Firmware Revision	Controller Firmware revision
11. Auxiliary Temperature 2	-60 to 150°F (-51.1 to 65.6°C)	
Write Single Coil (0x05)	0. Manual Valve Enabled Flag	0 = Disabled, 1 = Enabled Other coils are read-only
Write Single Register (0x06)	Same as above.	The max number of registers written at a time is 1. The limits are listed under 'Read Holding Register.'

APPENDIX K - BACnet Map**DEVICE OBJECT**

OBJECT INSTANCE	OBJECT NAME	WRITEABLE PROPERTY RANGES	OPTIONAL PROPERTIES SUPPORTED
<Controller Address>	"SUPERHEAT_CONTROLLER-###" where "###" is the controller address. Ex. "SUPERHEAT_CONTROLLER-001" for controller address 1	None	None

DEVICE PROPERTY DESCRIPTION

DEVICE PROPERTY DESCRIPTION	RANGE
System Status	Operational
Vendor Name	"Parker Hannifin"
Vendor Identifier	287
Model Name	"SPORLAN - KELVIN II - 4 TEMP"
Firmware Revision	Latest Revision formatted as <Major Version> '.' <Minor Version>
Application Software Version	"FW - P0117" for with display "FW - P0116" for without display
Protocol Version	1
Protocol Revision	14
Protocol Services Supported	Read Property Write Property Who-Is I-Am
Object Types Supported	Analog Input Object Analog Value Object Binary Output Object Binary Value Object Device Object Loop Object Multistate Value Object
Object List	List of all objects in Device
Maximum APDU Size	480
Segmentation Support	Segmentation Not Supported
APDU Timeout	3000 milliseconds
Number of APDU Retries	1
Device Address Binding	None
Database Revision	1
Max Master	127
Max Info Frames	1

APPENDIX K - BACnet Map (continued)**ANALOG INPUT OBJECTS**

OBJECT INSTANCE	OBJECT NAME	PROPERTY	RANGE	WRITEABLE
1	"PRESSURE"	Present Value	0.0 to 652.0	No
		Status Flags	None	No
		Event State	Normal	No
		Out of Service	False	No
		Units	PSI	No
2	"TEMPERATURE-1"	Present Value	-60.0 to 300.0	No
		Status Flags	None	No
		Event State	Normal	No
		Out of Service	False	No
		Units	°F	No
3	"TEMPERATURE-2"	Present Value	-60.0 to 300.0	No
		Status Flags	None	No
		Event State	Normal	No
		Out of Service	False	No
		Units	°F	No
4	"TEMPERATURE-3"	Present Value	-60.0 to 300.0	No
		Status Flags	None	No
		Event State	Normal	No
		Out of Service	False	No
		Units	°F	No
5	"TEMPERATURE-4"	Present Value	-60.0 to 300.0	No
		Status Flags	None	No
		Event State	Normal	No
		Out of Service	False	No
		Units	°F	No

ANALOG VALUE OBJECTS

OBJECT INSTANCE	OBJECT NAME	PROPERTY	RANGE	WRITEABLE
1	"SUPERHEAT"	Present Value		No
		Status Flags	None	No
		Event State	Normal	No
		Out of Service	False	No
		Units	Δ°F	No
2	"SATURATION_TEMPERATURE"	Present Value		No
		Status Flags	None	No
		Event State	Normal	No
		Out of Service	False	No
		Units	°F	No
3	"CURRENT_VALVE_POSITION"	Present Value		No
		Status Flags	None	No
		Event State	Normal	No
		Out of Service	False	No
		Units	Percent	No
4	"SUPERHEAT_SETPT"	Present Value		Yes
		Status Flags	None	No
		Event State	Normal	No
		Out of Service	False	No
		Units	Δ°F	No

APPENDIX K - BACnet Map (continued)**ANALOG VALUE OBJECTS**

OBJECT INSTANCE	OBJECT NAME	PROPERTY	RANGE	WRITEABLE
5	"DELAY_RELAY_ON"	Present Value		Yes
		Status Flags	None	No
		Event State	Normal	No
		Out of Service	False	No
		Units	Seconds	No
6	"DELAY_RELAY_OFF"	Present Value		Yes
		Status Flags	None	No
		Event State	Normal	No
		Out of Service	False	No
		Units	Seconds	No
7	"DELAY_STEPPER_PERCENT_OPEN"	Present Value		Yes
		Status Flags	None	No
		Event State	Normal	No
		Out of Service	False	No
		Units	Percent	No
8	"LOW_OPERATING_PRESSURE"	Present Value		Yes
		Status Flags	None	No
		Event State	Normal	No
		Out of Service	False	No
		Units	PSI	No
9	"MAXIMUM_OPERATING_PRESSURE"	Present Value		Yes
		Status Flags	None	No
		Event State	Normal	No
		Out of Service	False	No
		Units	PSI	No
10	"MANUAL_VALVE_POSITION"	Present Value		Yes
		Status Flags	None	No
		Event State	Normal	No
		Out of Service	False	No
		Units	Percent	No
11	"CUT_IN_TEMPERATURE"	Present Value		Yes
		Status Flags	None	No
		Event State	Normal	No
		Out of Service	False	No
		Units	°F	No
12	"CUT_OUT_TEMPERATURE"	Present Value		Yes
		Status Flags	None	No
		Event State	Normal	No
		Out of Service	False	No
		Units	°F	No
13	"MAXIMUM_VALVE_POSITION"	Present Value		Yes
		Status Flags	None	No
		Event State	Normal	No
		Out of Service	False	No
		Units	Percent	No
14	"PRESSURE_CALIB_OFFSET"	Present Value		Yes
		Status Flags	None	No
		Event State	Normal	No
		Out of Service	False	No
		PSI	PSI	No
15	"T1_OFFSET"	Present Value	-5.0 to 5.0	Yes
		Status Flags	None	No
		Event State	Normal	No
		Out of Service	False	No
		Units	Δ°F	No

APPENDIX K - BACnet Map (continued)**ANALOG VALUE OBJECTS**

OBJECT INSTANCE	OBJECT NAME	PROPERTY	RANGE	WRITEABLE
16	"T2_OFFSET"	Present Value	-5.0 to 5.0	Yes
		Status Flags	None	No
		Event State	Normal	No
		Out of Service	False	No
		Units	Δ°F	No
17	"T3_OFFSET"	Present Value	-5.0 to 5.0	Yes
		Status Flags	None	No
		Event State	Normal	No
		Out of Service	False	No
		Units	Δ°F	No
18	"T4_OFFSET"	Present Value	-5.0 to 5.0	Yes
		Status Flags	None	No
		Event State	Normal	No
		Out of Service	False	No
		Units	Δ°F	No
19	"BLEED_POSITION"	Present Value	0.00 to 100.00	Yes
		Status Flags	None	No
		Event State	Normal	No
		Out of Service	False	No
		Units	Percent	No
20	"BLEED_DELAY_TIME"	Present Value		Yes
		Status Flags	None	No
		Event State	Normal	No
		Out of Service	False	No
		Units	Seconds	No
21	"PID_DEADBAND"	Present Value		Yes
		Status Flags	None	No
		Event State	Normal	No
		Out of Service	False	No
		Units	Δ°F	No
22	"MINIMUM_RELAY_ON_TIME"	Present Value		Yes
		Status Flags	None	No
		Event State	Normal	No
		Out of Service	False	No
		Units	Seconds	No
23	"MINIMUM_RELAY_OFF_TIME"	Present Value		Yes
		Status Flags	None	No
		Event State	Normal	No
		Out of Service	False	No
		Units	Seconds	No
24	"LOW_SUPERHEAT_INTEGRAL""	Present Value		Yes
		Status Flags	None	No
		Event State	Normal	No
		Out of Service	False	No
		Units	No Units	No
25	"LOW_SUPERHEAT_ALARM_DELAY"	Present Value		Yes
		Status Flags	None	No
		Event State	Normal	No
		Out of Service	False	No
		Units	Seconds	No
26	"HIGH_SUPERHEAT_ALARM_DELAY"	Present Value		Yes
		Status Flags	None	No
		Event State	Normal	No
		Out of Service	False	No
		Units	Minutes	No

APPENDIX K - BACnet Map (continued)**BINARY OUTPUT OBJECTS**

OBJECT INSTANCE	OBJECT NAME	PROPERTY	RANGE	WRITEABLE
1	"RELAY-1"	Present Value	0 or 1	Yes
		Status Flags	None	No
		Event State	Normal	No
		Out of Service	False	No
		Polarity	Normal	No
		Priority Array	N/A	Not directly
		Relinquish Default	0 or 1	No
		Inactive Text	DE-ENERGIZED	No
2	"RELAY-2"	Present Value	0 or 1	Yes
		Status Flags	None	No
		Event State	Normal	No
		Out of Service	False	No
		Polarity	Normal	No
		Priority Array	N/A	Not directly
		Relinquish Default	0 or 1	No
		Inactive Text	DE-ENERGIZED	No
		Active Text	ENERGIZED	No

BINARY VALUE OBJECTS

OBJECT INSTANCE	OBJECT NAME	PROPERTY	RANGE	WRITEABLE
1	"MANUAL_VALVE_CONTROL"	Present Value	0 or 1	Yes
		Status Flags	None	No
		Event State	Normal	No
		Out of Service	False	No
		Inactive Text	DISABLED	No
		Active Text	ENABLED	No
2	"MANUAL_VALVE_DURATION"	Present Value	0 or 1	No
		Status Flags	None	No
		Event State	Normal	No
		Out of Service	False	No
		Inactive Text	DISABLED	No
		Active Text	ENABLED	No
3	"MANUAL_VALVE_TIMEOUT_OVERRIDE"	Present Value	0 or 1	No
		Status Flags	None	No
		Event State	Normal	No
		Out of Service	False	No
		Inactive Text	DISABLED	No
		Active Text	ENABLED	No
4	"PRESSURE_SENSOR_TYPE"	Present Value		Yes
		Status Flags	None	No
		Event State	Normal	No
		Out of Service	False	No
		Inactive Text	ABSOLUTE	No
		Active Text	GAUGE	No
5	"LOW_SUPERHEAT_ALARM"	Present Value	0 or 1	No
		Status Flags	None	No
		Event State	Normal	No
		Out of Service	False	No
		Inactive Text	INACTIVE	No
		Active Text	ACTIVE	No
6	"HIGH_SUPERHEAT_ALARM"	Present Value	0 or 1	No
		Status Flags	None	No
		Event State	Normal	No
		Out of Service	False	No
		Inactive Text	INACTIVE	No
		Active Text	ACTIVE	No

APPENDIX K - BACnet Map (continued)

BINARY VALUE OBJECTS

OBJECT INSTANCE	OBJECT NAME	PROPERTY	RANGE	WRITEABLE
7	"SUPERMARKET_MODE"	Present Value		Yes
		Status Flags	None	No
		Event State	Normal	No
		Out of Service	False	No
		Inactive Text	DISABLED	No
		Active Text	ENABLED	No
8	"HIGH_PRESSURE_ALARM_ENABLE"	Present Value		Yes
		Status Flags	None	No
		Event State	Normal	No
		Out of Service	False	No
		Inactive Text	DISABLED	No
		Active Text	ENABLED	No
9	"HIGH_SUPERHEAT_FAILSAFE"	Present Value		Yes
		Status Flags	None	No
		Event State	Normal	No
		Out of Service	False	No
		Inactive Text	DISABLED	No
		Active Text	ENABLED	No

LOOP OBJECTS

OBJECT INSTANCE	OBJECT NAME	PROPERTY	RANGE	WRITEABLE
1	"SUPERHEAT_CONTROL_LOOP"	Present Value	Minimum Output to Maximum Output	Yes
		Status Flags	Out of Service Flag	No
		Event State	Normal	No
		Out of Service	True – PID Loop Enabled False – PID Loop Disabled	No
		Output Units	Percent	No
		Manipulated Variable Reference	<ANALOG_VALUE, MANUAL_VALVE_POSITION>	No
		Controlled Variable Reference	<ANALOG_VALUE, SUPERHEAT>	No
		Controlled Variable Value	<PRESENT_VALUE OF "SUPERHEAT" OBJECT>	No
		Controlled Variable Units	Δ°F	No
		Setpoint Reference	<ANALOG_VALUE, SUPERHEAT_SETPT>	No
		Setpoint	<PRESENT_VALUE OF "SUPERHEAT_SETPT" OBJECT>	No
		Action	Direct	No
		Priority for Writing	16	No
		Proportional Constant	See Range for PID Setting	Yes
		Proportional Constant Units	No Units	No
		Integral Constant	See Range for PID Setting	Yes
		Integral Constant Units	No Units	No
		Derivative Constant	See Range for PID Setting	Yes
		Derivative Constant Units	No Units	No
Maximum Output	Maximum Valve Position	No		
Minimum Output	0%	No		

APPENDIX K - BACnet Map (continued)**MULTISTATE VALUE OBJECTS**

OBJECT INSTANCE	OBJECT NAME	PROPERTY	RANGE	WRITEABLE
1	"PRESSURE_TRANSDUCER_RANGE"	Present Value		Yes
		Status Flags	None	No
		Event State	Normal	No
		Out of Service	False	No
		Number of States	5	No
		State Text	1 = "Auto" 2 = "150 PSI" 3 = "300 PSI" 4 = "500 PSI" 5 = "652 PSI"	No
2	"VALVE_STEPS"	Present Value		Yes
		Status Flags	None	No
		Event State	Normal	No
		Out of Service	False	No
		Number of States	5	No
		State Text	1 = "1596" 2 = "3193" 3 = "2500" 4 = "6386" 5 = "500"	No
3	"REFRIGERANT_TYPE"	Present Value		Yes
		Status Flags	None	No
		Event State	Normal	No
		Out of Service	False	No
		Number of States	30	No
		State Text	1 = "R-22" 2 = "R-134A" 3 = "R-402A" 4 = "R-404A" 5 = "R-407A" 6 = "R-407C" 7 = "R-410A" 8 = "R-417A" 9 = "R-422A" 10 = "R-422D" 11 = "R-507A" 12 = "R-744" 13 = "R-245FA" 14 = "R-E5" 15 = "R-438A" 16 = "R-401B" 17 = "R-408A" 18 = "R-508A" 19 = "R-508B" 20 = "R-407F" 21 = "R-438A" 22 = "R-444B" 23 = "R-448A" 24 = "R-450A" 25 = "R-449A" 26 = "R-452A" 27 = "R-513A" 28 = "R-1336mzz" 29 = "R-32" 30 = "R-452B" 31 = "R-1234ZE" 32 = "R-124" 33 = "R-458A" 34 = "R-453A"	No
4	"TEMPERATURE_SENSOR_TYPE"	Present Value		Yes
		Status Flags	None	No
		Event State	Normal	No
		Out of Service	False	No
		Number of States	4	No
		State Text	1 = "3K" 2 = "2K" 3 = "98.6K" 4 = "10K-MT"	No
5	"TEMPERATURE_UNITS"	Present Value		Yes
		Status Flags	None	No
		Event State	Normal	No
		Out of Service	False	No
		Number of States	2	No
		State Text	1 = "Degrees F" 2 = "Degrees C"	No

APPENDIX K - BACnet Map (continued)**MULTISTATE VALUE OBJECTS**

OBJECT INSTANCE	OBJECT NAME	PROPERTY	RANGE	WRITEABLE
6	"CONTROLLER_ADDRESS"	Present Value		Yes
		Status Flags	None	No
		Event State	Normal	No
		Out of Service	False	No
		Number of States	255	No
		State Text	None	No
7	"PRESSURE_UNITS"	Present Value		Yes
		Status Flags	None	No
		Event State	Normal	No
		Out of Service	False	No
		Number of States	2	No
		State Text	1 = "PSI" 2 = "Bar"	No
8	"OPERATING_MODE"	Present Value		Yes
		Status Flags	None	No
		Event State	Normal	No
		Out of Service	False	No
		Number of States	5	No
		State Text	1 = "SETUP_MODE" 2 = "OFF_MODE" 3 = "COOLING_MODE" 4 = "PUMPDOWN_MODE" 5 = "STEPPER_OVERRIDE_MODE"	No

APPENDIX L - 2K Temperature Sensor Specifications

°C	°F	RANGE VDC
-51.1	-60	4.375 - 4.555
-50.6	-59	4.361 - 4.539
-50.0	-58	4.345 - 4.524
-49.4	-57	4.330 - 4.508
-48.9	-56	4.314 - 4.492
-48.3	-55	4.299 - 4.475
-47.8	-54	4.282 - 4.458
-47.2	-53	4.266 - 4.441
-46.7	-52	4.249 - 4.423
-46.1	-51	4.232 - 4.406
-45.6	-50	4.214 - 4.387
-45.0	-49	4.196 - 4.369
-44.4	-48	4.178 - 4.350
-43.9	-47	4.160 - 4.331
-43.3	-46	4.141 - 4.311
-42.8	-45	4.122 - 4.291
-42.2	-44	4.102 - 4.271
-41.7	-43	4.083 - 4.251
-41.1	-42	4.063 - 4.230
-40.6	-41	4.042 - 4.209
-40.0	-40	4.022 - 4.187
-39.4	-39	4.001 - 4.165
-38.9	-38	3.979 - 4.143
-38.3	-37	3.958 - 4.121
-37.8	-36	3.936 - 4.098
-37.2	-35	3.914 - 4.075
-36.7	-34	3.891 - 4.052
-36.1	-33	3.868 - 4.028
-35.6	-32	3.845 - 4.004
-35.0	-31	3.822 - 3.980
-34.4	-30	3.798 - 3.955
-33.9	-29	3.774 - 3.930
-33.3	-28	3.750 - 3.905
-32.8	-27	3.726 - 3.880
-32.2	-26	3.701 - 3.854
-31.7	-25	3.676 - 3.828
-31.1	-24	3.651 - 3.802
-30.6	-23	3.625 - 3.775
-30.0	-22	3.600 - 3.749
-29.4	-21	3.574 - 3.722
-28.9	-20	3.548 - 3.694
-28.3	-19	3.521 - 3.667
-27.8	-18	3.495 - 3.639
-27.2	-17	3.468 - 3.611
-26.7	-16	3.441 - 3.583
-26.1	-15	3.414 - 3.555
-25.6	-14	3.386 - 3.527
-25.0	-13	3.359 - 3.498
-24.4	-12	3.331 - 3.469
-23.9	-11	3.303 - 3.440
-23.3	-10	3.275 - 3.411
-22.8	-9	3.247 - 3.381
-22.2	-8	3.218 - 3.352
-21.7	-7	3.190 - 3.322

°C	°F	RANGE VDC
-21.1	-6	3.161 - 3.293
-20.6	-5	3.133 - 3.263
-20.0	-4	3.104 - 3.233
-19.4	-3	3.075 - 3.203
-18.9	-2	3.046 - 3.173
-18.3	-1	3.017 - 3.142
-17.8	0	2.988 - 3.112
-17.2	1	2.958 - 3.082
-16.7	2	2.929 - 3.051
-16.1	3	2.900 - 3.021
-15.6	4	2.871 - 2.990
-15.0	5	2.841 - 2.960
-14.4	6	2.812 - 2.929
-13.9	7	2.782 - 2.899
-13.3	8	2.753 - 2.868
-12.8	9	2.724 - 2.837
-12.2	10	2.694 - 2.807
-11.7	11	2.665 - 2.776
-11.1	12	2.636 - 2.746
-10.6	13	2.607 - 2.716
-10.0	14	2.577 - 2.685
-9.4	15	2.548 - 2.655
-8.9	16	2.519 - 2.625
-8.3	17	2.490 - 2.595
-7.8	18	2.462 - 2.565
-7.2	19	2.433 - 2.535
-6.7	20	2.404 - 2.505
-6.1	21	2.376 - 2.475
-5.6	22	2.347 - 2.446
-5.0	23	2.319 - 2.416
-4.4	24	2.291 - 2.387
-3.9	25	2.263 - 2.358
-3.3	26	2.235 - 2.329
-2.8	27	2.207 - 2.300
-2.2	28	2.179 - 2.271
-1.7	29	2.152 - 2.242
-1.1	30	2.125 - 2.214
-0.6	31	2.098 - 2.186
0.0	32	2.071 - 2.158
0.6	33	2.044 - 2.130
1.1	34	2.017 - 2.102
1.7	35	1.991 - 2.075
2.2	36	1.965 - 2.048
2.8	37	1.939 - 2.021
3.3	38	1.913 - 1.994
3.9	39	1.888 - 1.967
4.4	40	1.862 - 1.941
5.0	41	1.837 - 1.915
5.6	42	1.812 - 1.889
6.1	43	1.788 - 1.863
6.7	44	1.763 - 1.837
7.2	45	1.739 - 1.812
7.8	46	1.715 - 1.787
8.3	47	1.691 - 1.763

°C	°F	RANGE VDC
8.9	48	1.668 - 1.738
9.4	49	1.644 - 1.714
10.0	50	1.621 - 1.690
10.6	51	1.598 - 1.666
11.1	52	1.576 - 1.642
11.7	53	1.554 - 1.619
12.2	54	1.531 - 1.596
12.8	55	1.510 - 1.573
13.3	56	1.488 - 1.551
13.9	57	1.467 - 1.529
14.4	58	1.446 - 1.507
15.0	59	1.425 - 1.485
15.6	60	1.404 - 1.463
16.1	61	1.384 - 1.442
16.7	62	1.363 - 1.421
17.2	63	1.344 - 1.400
17.8	64	1.324 - 1.380
18.3	65	1.305 - 1.360
18.9	66	1.285 - 1.340
19.4	67	1.266 - 1.320
20.0	68	1.248 - 1.301
20.6	69	1.229 - 1.281
21.1	70	1.211 - 1.262
21.7	71	1.193 - 1.244
22.2	72	1.175 - 1.225
22.8	73	1.158 - 1.207
23.3	74	1.141 - 1.189
23.9	75	1.124 - 1.171
24.4	76	1.107 - 1.154
25.0	77	1.090 - 1.137
25.6	78	1.074 - 1.120
26.1	79	1.058 - 1.103
26.7	80	1.042 - 1.086
27.2	81	1.026 - 1.070
27.8	82	1.011 - 1.054
28.3	83	0.996 - 1.038
28.9	84	0.981 - 1.022
29.4	85	0.966 - 1.007
30.0	86	0.951 - 0.992
30.6	87	0.937 - 0.977
31.1	88	0.923 - 0.962
31.7	89	0.909 - 0.948
32.2	90	0.895 - 0.933
32.8	91	0.882 - 0.919
33.3	92	0.868 - 0.905
33.9	93	0.855 - 0.892
34.4	94	0.842 - 0.878
35.0	95	0.830 - 0.865
35.6	96	0.817 - 0.852
36.1	97	0.805 - 0.839
36.7	98	0.792 - 0.826
37.2	99	0.780 - 0.814
37.8	100	0.769 - 0.801
38.3	101	0.757 - 0.789

°C	°F	RANGE VDC
38.9	102	0.746 - 0.777
39.4	103	0.734 - 0.766
40.0	104	0.723 - 0.754
40.6	105	0.712 - 0.743
41.1	106	0.702 - 0.731
41.7	107	0.691 - 0.720
42.2	108	0.681 - 0.710
42.8	109	0.670 - 0.699
43.3	110	0.660 - 0.688
43.9	111	0.650 - 0.678
44.4	112	0.641 - 0.668
45.0	113	0.631 - 0.658
45.6	114	0.621 - 0.648
46.1	115	0.612 - 0.638
46.7	116	0.603 - 0.629
47.2	117	0.594 - 0.619
47.8	118	0.585 - 0.610
48.3	119	0.576 - 0.601
48.9	120	0.568 - 0.592
49.4	121	0.559 - 0.583
50.0	122	0.551 - 0.574
50.6	123	0.543 - 0.566
51.1	124	0.535 - 0.557
51.7	125	0.527 - 0.549
52.2	126	0.519 - 0.541
52.8	127	0.511 - 0.533
53.3	128	0.504 - 0.525
53.9	129	0.496 - 0.517
54.4	130	0.489 - 0.510
55.0	131	0.482 - 0.502
55.6	132	0.475 - 0.495
56.1	133	0.468 - 0.488
56.7	134	0.461 - 0.480
57.2	135	0.454 - 0.473
57.8	136	0.447 - 0.466
58.3	137	0.441 - 0.460
58.9	138	0.434 - 0.453
59.4	139	0.428 - 0.446
60.0	140	0.422 - 0.440
60.6	141	0.416 - 0.433
61.1	142	0.410 - 0.427
61.7	143	0.404 - 0.421
62.2	144	0.398 - 0.415
62.8	145	0.392 - 0.409
63.3	146	0.386 - 0.403
63.9	147	0.381 - 0.397
64.4	148	0.375 - 0.391
65.0	149	0.370 - 0.386
65.6	150	0.365 - 0.380

APPENDIX M - 3K Temperature Sensor Specifications

°C	°F	RANGE VDC
-51.1	-60	4.747 - 4.941
-50.6	-59	4.741 - 4.935
-50.0	-58	4.735 - 4.928
-49.4	-57	4.728 - 4.921
-48.9	-56	4.722 - 4.915
-48.3	-55	4.715 - 4.907
-47.8	-54	4.708 - 4.900
-47.2	-53	4.700 - 4.893
-46.7	-52	4.693 - 4.885
-46.1	-51	4.685 - 4.877
-45.6	-50	4.677 - 4.868
-45.0	-49	4.669 - 4.860
-44.4	-48	4.660 - 4.851
-43.9	-47	4.651 - 4.842
-43.3	-46	4.642 - 4.832
-42.8	-45	4.633 - 4.823
-42.2	-44	4.623 - 4.813
-41.7	-43	4.613 - 4.802
-41.1	-42	4.603 - 4.792
-40.6	-41	4.593 - 4.781
-40.0	-40	4.582 - 4.769
-39.4	-39	4.571 - 4.758
-38.9	-38	4.559 - 4.746
-38.3	-37	4.547 - 4.734
-37.8	-36	4.535 - 4.721
-37.2	-35	4.523 - 4.708
-36.7	-34	4.510 - 4.695
-36.1	-33	4.497 - 4.681
-35.6	-32	4.484 - 4.667
-35.0	-31	4.470 - 4.653
-34.4	-30	4.456 - 4.638
-33.9	-29	4.441 - 4.623
-33.3	-28	4.426 - 4.608
-32.8	-27	4.411 - 4.592
-32.2	-26	4.395 - 4.576
-31.7	-25	4.379 - 4.559
-31.1	-24	4.363 - 4.542
-30.6	-23	4.346 - 4.525
-30.0	-22	4.329 - 4.507
-29.4	-21	4.312 - 4.489
-28.9	-20	4.294 - 4.470
-28.3	-19	4.275 - 4.451
-27.8	-18	4.256 - 4.431
-27.2	-17	4.237 - 4.411
-26.7	-16	4.218 - 4.391
-26.1	-15	4.198 - 4.370
-25.6	-14	4.177 - 4.349
-25.0	-13	4.157 - 4.327
-24.4	-12	4.135 - 4.305
-23.9	-11	4.114 - 4.283
-23.3	-10	4.092 - 4.260
-22.8	-9	4.069 - 4.237
-22.2	-8	4.046 - 4.213
-21.7	-7	4.023 - 4.189

°C	°F	RANGE VDC
-21.1	-6	3.999 - 4.164
-20.6	-5	3.975 - 4.139
-20.0	-4	3.951 - 4.114
-19.4	-3	3.926 - 4.088
-18.9	-2	3.901 - 4.062
-18.3	-1	3.875 - 4.035
-17.8	0	3.849 - 4.008
-17.2	1	3.823 - 3.981
-16.7	2	3.796 - 3.953
-16.1	3	3.769 - 3.924
-15.6	4	3.741 - 3.896
-15.0	5	3.713 - 3.867
-14.4	6	3.685 - 3.837
-13.9	7	3.657 - 3.808
-13.3	8	3.628 - 3.778
-12.8	9	3.598 - 3.747
-12.2	10	3.569 - 3.717
-11.7	11	3.539 - 3.686
-11.1	12	3.509 - 3.654
-10.6	13	3.478 - 3.623
-10.0	14	3.448 - 3.591
-9.4	15	3.417 - 3.558
-8.9	16	3.385 - 3.526
-8.3	17	3.354 - 3.493
-7.8	18	3.322 - 3.460
-7.2	19	3.290 - 3.427
-6.7	20	3.258 - 3.393
-6.1	21	3.226 - 3.360
-5.6	22	3.193 - 3.326
-5.0	23	3.160 - 3.292
-4.4	24	3.127 - 3.257
-3.9	25	3.094 - 3.223
-3.3	26	3.061 - 3.189
-2.8	27	3.028 - 3.154
-2.2	28	2.994 - 3.119
-1.7	29	2.961 - 3.084
-1.1	30	2.927 - 3.049
-0.6	31	2.894 - 3.014
0.0	32	2.860 - 2.979
0.6	33	2.826 - 2.944
1.1	34	2.792 - 2.909
1.7	35	2.758 - 2.874
2.2	36	2.725 - 2.838
2.8	37	2.691 - 2.803
3.3	38	2.657 - 2.768
3.9	39	2.623 - 2.733
4.4	40	2.590 - 2.698
5.0	41	2.556 - 2.663
5.6	42	2.522 - 2.628
6.1	43	2.489 - 2.593
6.7	44	2.455 - 2.558
7.2	45	2.422 - 2.524
7.8	46	2.389 - 2.489
8.3	47	2.356 - 2.455

°C	°F	RANGE VDC
8.9	48	2.323 - 2.421
9.4	49	2.290 - 2.386
10.0	50	2.258 - 2.353
10.6	51	2.226 - 2.319
11.1	52	2.193 - 2.285
11.7	53	2.161 - 2.252
12.2	54	2.130 - 2.219
12.8	55	2.098 - 2.186
13.3	56	2.067 - 2.154
13.9	57	2.036 - 2.121
14.4	58	2.005 - 2.089
15.0	59	1.974 - 2.057
15.6	60	1.944 - 2.026
16.1	61	1.914 - 1.994
16.7	62	1.884 - 1.963
17.2	63	1.854 - 1.932
17.8	64	1.825 - 1.902
18.3	65	1.796 - 1.872
18.9	66	1.767 - 1.842
19.4	67	1.739 - 1.812
20.0	68	1.711 - 1.783
20.6	69	1.683 - 1.754
21.1	70	1.656 - 1.725
21.7	71	1.628 - 1.697
22.2	72	1.602 - 1.669
22.8	73	1.575 - 1.641
23.3	74	1.549 - 1.614
23.9	75	1.523 - 1.587
24.4	76	1.497 - 1.561
25.0	77	1.472 - 1.534
25.6	78	1.447 - 1.508
26.1	79	1.422 - 1.483
26.7	80	1.398 - 1.457
27.2	81	1.374 - 1.432
27.8	82	1.351 - 1.408
28.3	83	1.327 - 1.383
28.9	84	1.304 - 1.360
29.4	85	1.282 - 1.336
30.0	86	1.259 - 1.313
30.6	87	1.237 - 1.290
31.1	88	1.216 - 1.267
31.7	89	1.194 - 1.245
32.2	90	1.173 - 1.223
32.8	91	1.153 - 1.202
33.3	92	1.132 - 1.180
33.9	93	1.112 - 1.159
34.4	94	1.093 - 1.139
35.0	95	1.073 - 1.119
35.6	96	1.054 - 1.099
36.1	97	1.035 - 1.079
36.7	98	1.017 - 1.060
37.2	99	0.998 - 1.041
37.8	100	0.981 - 1.022
38.3	101	0.963 - 1.004

°C	°F	RANGE VDC
38.9	102	0.946 - 0.986
39.4	103	0.929 - 0.968
40.0	104	0.912 - 0.951
40.6	105	0.895 - 0.934
41.1	106	0.879 - 0.917
41.7	107	0.863 - 0.900
42.2	108	0.848 - 0.884
42.8	109	0.832 - 0.868
43.3	110	0.817 - 0.852
43.9	111	0.803 - 0.837
44.4	112	0.788 - 0.822
45.0	113	0.774 - 0.807
45.6	114	0.760 - 0.792
46.1	115	0.746 - 0.778
46.7	116	0.732 - 0.764
47.2	117	0.719 - 0.750
47.8	118	0.706 - 0.736
48.3	119	0.693 - 0.723
48.9	120	0.681 - 0.710
49.4	121	0.668 - 0.697
50.0	122	0.656 - 0.684
50.6	123	0.644 - 0.672
51.1	124	0.633 - 0.660
51.7	125	0.621 - 0.648
52.2	126	0.610 - 0.636
52.8	127	0.599 - 0.624
53.3	128	0.588 - 0.613
53.9	129	0.577 - 0.602
54.4	130	0.567 - 0.591
55.0	131	0.557 - 0.580
55.6	132	0.547 - 0.570
56.1	133	0.537 - 0.560
56.7	134	0.527 - 0.550
57.2	135	0.518 - 0.540
57.8	136	0.508 - 0.530
58.3	137	0.499 - 0.520
58.9	138	0.490 - 0.511
59.4	139	0.481 - 0.502
60.0	140	0.473 - 0.493
60.6	141	0.464 - 0.484
61.1	142	0.456 - 0.475
61.7	143	0.448 - 0.467
62.2	144	0.440 - 0.459
62.8	145	0.432 - 0.450
63.3	146	0.424 - 0.442
63.9	147	0.417 - 0.435
64.4	148	0.409 - 0.427
65.0	149	0.402 - 0.419
65.6	150	0.395 - 0.412

APPENDIX N - 10K Temperature Sensor Specifications

°C	°F	RANGE VDC
-51.1	-60	4.949 - 4.956
-50.6	-59	4.947 - 4.954
-50.0	-58	4.945 - 4.952
-49.4	-57	4.942 - 4.950
-48.9	-56	4.940 - 4.948
-48.3	-55	4.938 - 4.946
-47.8	-54	4.936 - 4.944
-47.2	-53	4.933 - 4.942
-46.7	-52	4.931 - 4.939
-46.1	-51	4.928 - 4.937
-45.6	-50	4.925 - 4.935
-45.0	-49	4.922 - 4.932
-44.4	-48	4.919 - 4.929
-43.9	-47	4.916 - 4.927
-43.3	-46	4.913 - 4.924
-42.8	-45	4.910 - 4.921
-42.2	-44	4.906 - 4.918
-41.7	-43	4.903 - 4.915
-41.1	-42	4.899 - 4.911
-40.6	-41	4.895 - 4.908
-40.0	-40	4.892 - 4.905
-39.4	-39	4.887 - 4.902
-38.9	-38	4.884 - 4.898
-38.3	-37	4.879 - 4.894
-37.8	-36	4.875 - 4.890
-37.2	-35	4.871 - 4.886
-36.7	-34	4.866 - 4.882
-36.1	-33	4.861 - 4.878
-35.6	-32	4.856 - 4.873
-35.0	-31	4.851 - 4.869
-34.4	-30	4.846 - 4.864
-33.9	-29	4.841 - 4.859
-33.3	-28	4.835 - 4.854
-32.8	-27	4.830 - 4.849
-32.2	-26	4.824 - 4.844
-31.7	-25	4.818 - 4.839
-31.1	-24	4.812 - 4.833
-30.6	-23	4.805 - 4.827
-30.0	-22	4.799 - 4.821
-29.4	-21	4.792 - 4.816
-28.9	-20	4.785 - 4.809
-28.3	-19	4.778 - 4.802
-27.8	-18	4.771 - 4.796
-27.2	-17	4.763 - 4.789
-26.7	-16	4.756 - 4.782
-26.1	-15	4.748 - 4.775
-25.6	-14	4.739 - 4.768
-25.0	-13	4.731 - 4.760
-24.4	-12	4.722 - 4.753
-23.9	-11	4.714 - 4.744
-23.3	-10	4.705 - 4.736
-22.8	-9	4.696 - 4.728
-22.2	-8	4.686 - 4.719
-21.7	-7	4.677 - 4.710
-21.1	-6	4.667 - 4.701
-20.6	-5	4.656 - 4.692
-20.0	-4	4.646 - 4.682
-19.4	-3	4.635 - 4.673
-18.9	-2	4.625 - 4.662
-18.3	-1	4.613 - 4.652
-17.8	0	4.602 - 4.642

°C	°F	RANGE VDC
-17.2	1	4.590 - 4.631
-16.7	2	4.579 - 4.620
-16.1	3	4.566 - 4.608
-15.6	4	4.552 - 4.598
-15.0	5	4.540 - 4.585
-14.4	6	4.527 - 4.574
-13.9	7	4.514 - 4.561
-13.3	8	4.500 - 4.547
-12.8	9	4.487 - 4.535
-12.2	10	4.472 - 4.522
-11.7	11	4.459 - 4.509
-11.1	12	4.443 - 4.495
-10.6	13	4.427 - 4.481
-10.0	14	4.412 - 4.466
-9.4	15	4.396 - 4.453
-8.9	16	4.381 - 4.437
-8.3	17	4.364 - 4.421
-7.8	18	4.348 - 4.406
-7.2	19	4.330 - 4.390
-6.7	20	4.314 - 4.374
-6.1	21	4.296 - 4.357
-5.6	22	4.277 - 4.341
-5.0	23	4.260 - 4.324
-4.4	24	4.240 - 4.307
-3.9	25	4.223 - 4.288
-3.3	26	4.203 - 4.270
-2.8	27	4.185 - 4.252
-2.2	28	4.164 - 4.233
-1.7	29	4.145 - 4.215
-1.1	30	4.124 - 4.195
-0.6	31	4.102 - 4.177
0.0	32	4.082 - 4.156
0.6	33	4.060 - 4.137
1.1	34	4.040 - 4.115
1.7	35	4.017 - 4.093
2.2	36	3.996 - 4.074
2.8	37	3.972 - 4.051
3.3	38	3.951 - 4.031
3.9	39	3.927 - 4.008
4.4	40	3.902 - 3.987
5.0	41	3.880 - 3.963
5.6	42	3.855 - 3.942
6.1	43	3.832 - 3.917
6.7	44	3.807 - 3.893
7.2	45	3.784 - 3.870
7.8	46	3.758 - 3.845
8.3	47	3.734 - 3.823
8.9	48	3.707 - 3.797
9.4	49	3.680 - 3.774
10.0	50	3.655 - 3.748
10.6	51	3.628 - 3.724
11.1	52	3.603 - 3.696
11.7	53	3.576 - 3.669
12.2	54	3.550 - 3.645
12.8	55	3.522 - 3.618
13.3	56	3.497 - 3.593
13.9	57	3.468 - 3.565
14.4	58	3.438 - 3.540
15.0	59	3.412 - 3.511
15.6	60	3.383 - 3.486
16.1	61	3.357 - 3.456

°C	°F	RANGE VDC
16.7	62	3.327 - 3.427
17.2	63	3.301 - 3.401
17.8	64	3.271 - 3.372
18.3	65	3.244 - 3.346
18.9	66	3.214 - 3.316
19.4	67	3.183 - 3.289
20.0	68	3.156 - 3.260
20.6	69	3.125 - 3.233
21.1	70	3.098 - 3.202
21.7	71	3.067 - 3.171
22.2	72	3.040 - 3.144
22.8	73	3.009 - 3.114
23.3	74	2.982 - 3.086
23.9	75	2.951 - 3.056
24.4	76	2.919 - 3.028
25.0	77	2.891 - 2.998
25.6	78	2.861 - 2.970
26.1	79	2.833 - 2.938
26.7	80	2.802 - 2.907
27.2	81	2.774 - 2.880
27.8	82	2.744 - 2.849
28.3	83	2.716 - 2.821
28.9	84	2.685 - 2.790
29.4	85	2.653 - 2.763
30.0	86	2.626 - 2.732
30.6	87	2.595 - 2.704
31.1	88	2.568 - 2.673
31.7	89	2.538 - 2.642
32.2	90	2.510 - 2.614
32.8	91	2.480 - 2.584
33.3	92	2.453 - 2.556
33.9	93	2.423 - 2.526
34.4	94	2.392 - 2.499
35.0	95	2.365 - 2.469
35.6	96	2.336 - 2.442
36.1	97	2.309 - 2.411
36.7	98	2.280 - 2.381
37.2	99	2.253 - 2.354
37.8	100	2.224 - 2.324
38.3	101	2.198 - 2.298
38.9	102	2.170 - 2.269
39.4	103	2.140 - 2.242
40.0	104	2.115 - 2.213
40.6	105	2.086 - 2.188
41.1	106	2.061 - 2.158
41.7	107	2.034 - 2.129
42.2	108	2.009 - 2.104
42.8	109	1.981 - 2.076
43.3	110	1.957 - 2.051
43.9	111	1.930 - 2.023
44.4	112	1.902 - 1.998
45.0	113	1.878 - 1.971
45.6	114	1.852 - 1.947
46.1	115	1.829 - 1.919
46.7	116	1.803 - 1.892
47.2	117	1.780 - 1.868
47.8	118	1.754 - 1.842
48.3	119	1.732 - 1.819
48.9	120	1.707 - 1.793
49.4	121	1.681 - 1.770
50.0	122	1.659 - 1.745

°C	°F	RANGE VDC
50.6	123	1.635 - 1.722
51.1	124	1.614 - 1.697
51.7	125	1.590 - 1.672
52.2	126	1.569 - 1.650
52.8	127	1.546 - 1.626
53.3	128	1.525 - 1.605
53.9	129	1.503 - 1.581
54.4	130	1.479 - 1.560
55.0	131	1.459 - 1.537
55.6	132	1.438 - 1.517
56.1	133	1.418 - 1.493
56.7	134	1.397 - 1.471
57.2	135	1.378 - 1.451
57.8	136	1.357 - 1.429
58.3	137	1.338 - 1.410
58.9	138	1.318 - 1.389
59.4	139	1.297 - 1.370
60.0	140	1.279 - 1.349
60.6	141	1.260 - 1.330
61.1	142	1.242 - 1.309
61.7	143	1.223 - 1.289
62.2	144	1.206 - 1.272
62.8	145	1.187 - 1.252
63.3	146	1.171 - 1.235
63.9	147	1.153 - 1.216
64.4	148	1.134 - 1.199
65.0	149	1.118 - 1.180
65.6	150	1.101 - 1.164
47.8	118	1.754 - 1.842
48.3	119	1.732 - 1.819
48.9	120	1.707 - 1.793
49.4	121	1.681 - 1.770
50.0	122	1.659 - 1.745
50.6	123	1.635 - 1.722
51.1	124	1.614 - 1.697
51.7	125	1.590 - 1.672
52.2	126	1.569 - 1.650
52.8	127	1.546 - 1.626
53.3	128	1.525 - 1.605
53.9	129	1.503 - 1.581
54.4	130	1.479 - 1.560
55.0	131	1.459 - 1.537
55.6	132	1.438 - 1.517
56.1	133	1.418 - 1.493
56.7	134	1.397 - 1.471
57.2	135	1.378 - 1.451
57.8	136	1.357 - 1.429
58.3	137	1.338 - 1.410
58.9	138	1.318 - 1.389
59.4	139	1.297 - 1.370
60.0	140	1.279 - 1.349
60.6	141	1.260 - 1.330
61.1	142	1.242 - 1.309
61.7	143	1.223 - 1.289
62.2	144	1.206 - 1.272
62.8	145	1.187 - 1.252
63.3	146	1.171 - 1.235
63.9	147	1.153 - 1.216
64.4	148	1.134 - 1.199
65.0	149	1.118 - 1.180
65.6	150	1.101 - 1.164

OFFER OF SALE

The goods, services or work (referred to as the “Products”) offered by **Parker-Hannifin Corporation**, its subsidiaries, groups, divisions, and authorized distributors (“Seller”) are offered for sale at prices indicated in the offer, or as may be established by Seller. The offer to sell the Products and acceptance of Seller’s offer by any customer (“Buyer”) is contingent upon, and will be governed by all of the terms and conditions contained in this Offer of Sale. Buyer’s order for any Products specified in Buyer’s purchase document or Seller’s offer, proposal or quote (“Quote”) attached to the purchase order, when communicated to Seller verbally, or in writing, shall constitute acceptance of this offer.

1. Terms and Conditions. Seller’s willingness to offer Products for sale or accept an order for Products is subject to the terms and conditions contained in this Offer of Sale or any newer version of the same, published by Seller electronically at www.parker.com/saleterms/. Seller objects to any contrary or additional terms or conditions of Buyer’s order or any other document or other communication issued by Buyer.

2. Price; Payment. Prices stated on Seller’s Quote are valid for thirty (30) days, except as explicitly otherwise stated therein, and do not include any sales, use, or other taxes or duties unless specifically stated. Seller reserves the right to modify prices to adjust for any raw material price fluctuations. Unless otherwise specified by Seller, all prices are F.C.A. Seller’s facility (INCO-TERMS 2010). Payment is subject to credit approval and payment for all purchases is due thirty (30) days from the date of invoice (or such date as may be specified by Seller’s Credit Department). Unpaid invoices beyond the specified payment date incur interest at the rate of 1.5% per month or the maximum allowable rate under applicable law.

3. Shipment; Delivery; Title and Risk of Loss. All delivery dates are approximate. Seller is not responsible for damages resulting from any delay. Regardless of the manner of shipment, delivery occurs and title and risk of loss or damage pass to Buyer, upon placement of the Products with the shipment carrier at Seller’s facility. Unless otherwise stated, Seller may exercise its judgment in choosing the carrier and means of delivery. No deferral of shipment at Buyer’s request beyond the respective dates indicated will be made except on terms that will indemnify, defend and hold Seller harmless against all loss and additional expense. Buyer shall be responsible for any additional shipping charges incurred by Seller due to Buyer’s acts or omissions.

4. Warranty. Seller warrants that the Products sold hereunder shall be free from defects in material or workmanship for a period of twelve (12) months from the date of delivery or 2,000 hours of normal use, whichever occurs first. All prices are based upon the exclusive limited warranty stated above, and upon the following disclaimer: **DISCLAIMER OF WARRANTY: THIS WARRANTY IS THE SOLE AND ENTIRE WARRANTY PERTAINING TO PRODUCTS PROVIDED. SELLER DISCLAIMS ALL OTHER WARRANTIES, EXPRESS AND IMPLIED, INCLUDING DESIGN, MERCHANTABILITY AND FITNESS FOR A PARTICULAR PURPOSE.**

5. Claims; Commencement of Actions. Buyer shall promptly inspect all Products upon receipt. No claims for shortages will be allowed unless reported to the Seller within ten (10) days of delivery. No other claims against Seller will be allowed unless asserted in writing within thirty (30) days after delivery. Buyer shall notify Seller of any alleged breach of warranty within thirty (30) days after the date the defect is or should have been discovered by Buyer. Any claim or action against Seller based upon breach of contract or any other theory, including tort, negligence, or otherwise must be commenced within twelve (12) months from the date of the alleged breach or other alleged event, without regard to the date of discovery.

6. LIMITATION OF LIABILITY. IN THE EVENT OF A BREACH OF WARRANTY, SELLER WILL, AT ITS OPTION, REPAIR OR REPLACE A DEFECTIVE PRODUCT, OR REFUND THE PURCHASE PRICE WITHIN A REASONABLE PERIOD OF TIME. **IN NO EVENT IS SELLER LIABLE FOR ANY SPECIAL, INDIRECT, INCIDENTAL OR CONSEQUENTIAL DAMAGES ARISING OUT OF, OR AS THE RESULT OF, THE SALE, DELIVERY, NON-DELIVERY, SERVICING, USE OR LOSS OF USE OF THE PRODUCTS OR ANY PART THEREOF, OR FOR ANY CHARGES OR EXPENSES OF ANY NATURE INCURRED WITHOUT SELLER’S WRITTEN CONSENT, WHETHER BASED IN CONTRACT, TORT OR OTHER LEGAL THEORY. IN NO EVENT SHALL SELLER’S LIABILITY UNDER ANY CLAIM MADE BY BUYER EXCEED THE PURCHASE PRICE OF THE PRODUCTS.**

7. User Responsibility. The user, through its own analysis and testing, is solely responsible for making the final selection of the system and Product and assuring that all performance, endurance, maintenance, safety and warning requirements of the application are met. The user must analyze all aspects of the applica-

tion and follow applicable industry standards and Product information. If Seller provides Product or system options based upon data or specifications provided by the user, the user is responsible for determining that such data and specifications are suitable and sufficient for all applications and reasonably foreseeable uses of the Products or systems.

8. Loss to Buyer’s Property. Any designs, tools, patterns, materials, drawings, confidential information or equipment furnished by Buyer or any other items which become Buyer’s property, will be considered obsolete and may be destroyed by Seller after two (2) consecutive years have elapsed without Buyer ordering the items manufactured using such property. Seller shall not be responsible for any loss or damage to such property while it is in Seller’s possession or control.

9. Special Tooling. A tooling charge may be imposed for any special tooling, including without limitation, dies, fixtures, molds and patterns, acquired to manufacture Products. Such special tooling shall be and remain Seller’s property notwithstanding payment of any charges by Buyer. In no event will Buyer acquire any interest in apparatus belonging to Seller which is utilized in the manufacture of the Products, even if such apparatus has been specially converted or adapted for such manufacture and notwithstanding any charges paid by Buyer. Unless otherwise agreed, Seller has the right to alter, discard or otherwise dispose of any special tooling or other property in its sole discretion at any time.

10. Buyer’s Obligation; Rights of Seller. To secure payment of all sums due or otherwise, Seller retains a security interest in all Products delivered to Buyer and this agreement is deemed to be a Security Agreement under the Uniform Commercial Code. Buyer authorizes Seller as its attorney to execute and file on Buyer’s behalf all documents Seller deems necessary to perfect its security interest.

11. Improper Use and Indemnity. Buyer shall indemnify, defend, and hold Seller harmless from any losses, claims, liabilities, damages, lawsuits, judgments and costs (including attorney fees and defense costs), whether for personal injury, property damage, patent, trademark or copyright infringement or any other claim, brought by or incurred by Buyer, Buyer’s employees, or any other person, arising out of: (a) improper selection, application, design, specification or other misuse of Products purchased by Buyer from Seller; (b) any act or omission, negligent or otherwise, of Buyer; (c) Seller’s use of patterns, plans, drawings, or specifications furnished by Buyer to manufacture Products; or (d) Buyer’s failure to comply with these terms and conditions. Seller shall not indemnify Buyer under any circumstance except as otherwise provided.

12. Cancellations and Changes. Buyer may not cancel or modify or cancel any order for any reason, except with Seller’s written consent and upon terms that will indemnify, defend and hold Seller harmless against all direct, incidental and consequential loss or damage. Seller may change Product features, specifications, designs and availability.

13. Limitation on Assignment. Buyer may not assign its rights or obligations under this agreement without the prior written consent of Seller.

14. Force Majeure. Seller does not assume the risk and is not liable for delay or failure to perform any of Seller’s obligations by reason of events or circumstances beyond its reasonable control (hereinafter “Events of Force Majeure”). Events of Force Majeure shall include without limitation: accidents, strikes or labor disputes, acts of any government or government agency, acts of nature, delays or failures in delivery from carriers or suppliers, shortages of materials, or any other cause beyond Seller’s reasonable control.

15. Waiver and Severability. Failure to enforce any provision of this agreement will not invalidate that provision; nor will any such failure prejudice Seller’s right to enforce that provision in the future. Invalidation of any provision of this agreement by legislation or other rule of law shall not invalidate any other provision herein. The remaining provisions of this agreement will remain in full force and effect.

16. Termination. Seller may terminate this agreement for any reason and at any time by giving Buyer thirty (30) days prior written notice. Seller may immediately terminate this agreement, in writing, if Buyer: (a)

breaches any provision of this agreement (b) appoints a trustee, receiver or custodian for all or any part of Buyer’s property (c) files a petition for relief in bankruptcy on its own behalf, or one filed by a third party (d) makes an assignment for the benefit of creditors; or (e) dissolves its business or liquidates all or a majority of its assets.

17. Governing Law. This agreement and the sale and delivery of all Products are deemed to have taken place in, and shall be governed and construed in accordance with, the laws of the State of Ohio, as applicable to contracts executed and wholly performed therein and without regard to conflicts of laws principles. Buyer irrevocably agrees and consents to the exclusive jurisdiction and venue of the courts of Cuyahoga County, Ohio with respect to any dispute, controversy or claim arising out of or relating to this agreement.

18. Indemnity for Infringement of Intellectual Property Rights. Seller is not liable for infringement of any patents, trademarks, copyrights, trade dress, trade secrets or similar rights except as provided in this Section. Seller will defend and indemnify Buyer against allegations of infringement of U.S. patents, U.S. trademarks, copyrights, trade dress and trade secrets (“Intellectual Property Rights”). Seller will defend at its expense and will pay the cost of any settlement or damages awarded in an action brought against Buyer based on an allegation that a Product sold pursuant to this agreement infringes the Intellectual Property Rights of a third party. Seller’s obligation to defend and indemnify Buyer is contingent on Buyer notifying Seller within ten (10) days after Buyer becomes aware of such allegations of infringement, and Seller having sole control over the defense of any allegations or actions including all negotiations for settlement or compromise. If a Product is subject to a claim that it infringes the Intellectual Property Rights of a third party, Seller may, at its sole expense and option, procure for Buyer the right to continue using the Product, replace or modify the Product so as to make it noninfringing, or offer to accept return of the Product and refund the purchase price less a reasonable allowance for depreciation. Notwithstanding the foregoing, Seller is not liable for claims of infringement based on information provided by Buyer, or directed to Products delivered hereunder for which the designs are specified in whole or part by Buyer, or infringements resulting from the modification, combination or use in a system of any Product sold hereunder. The foregoing provisions of this Section constitute Seller’s sole and exclusive liability and Buyer’s sole and exclusive remedy for infringement of Intellectual Property Rights.

19. Entire Agreement. This agreement contains the entire agreement between the Buyer and Seller and constitutes the final, complete and exclusive expression of the terms of sale. All prior or contemporaneous written or oral agreements or negotiations with respect to the subject matter are herein merged. The terms contained herein may not be modified unless in writing and signed by an authorized representative of Seller.

20. Compliance with Laws. Buyer agrees to comply with all applicable laws, regulations, and industry and professional standards of care, including those of the United Kingdom, the United States of America, and the country or countries in which Buyer may operate, including without limitation the U. K. Bribery Act, the U.S. Foreign Corrupt Practices Act (“FCPA”), the U.S. Anti-Kickback Act (“Anti-Kickback Act”) and the U.S. Food Drug and Cosmetic Act (“FDCA”), each as currently amended, and the rules and regulations promulgated by the U.S. Food and Drug Administration (“FDA”), and agrees to indemnify and hold harmless Seller from the consequences of any violation of such provisions by Buyer, its employees or agents. Buyer acknowledges that it is familiar with the provisions of the U. K. Bribery Act, the FCPA, the FDA, and the Anti-Kickback Act, and certifies that Buyer will adhere to the requirements thereof. In particular, Buyer represents and agrees that Buyer will not make any payment or give anything of value, directly or indirectly to any governmental official, any foreign political party or official thereof, any candidate for foreign political office, or any commercial entity or person, for the purpose of influencing such person to purchase Products or otherwise benefit the business of Seller.



Parker Hannifin Corporation
Sporlan Division
206 Lange Drive, Washington, MO 63090 USA
phone 636 239 1111
fax 636 239 9130
www.sporlan.com