



---

# 605C Frequency Inverter

Product Manual

HA465013U001 Issue 8

Compatible with Version 5.x Software

© Copyright 2005 SSD Drives Limited (formerly Eurotherm Drives Limited)

All rights strictly reserved. No part of this document may be stored in a retrieval system, or transmitted in any form or by any means to persons not employed by an SSD Drives company without written permission from SSD Drives Ltd.

Although every effort has been taken to ensure the accuracy of this document it may be necessary, without notice, to make amendments or correct omissions. SSD Drives cannot accept responsibility for damage, injury, or expenses resulting therefrom.

## WARRANTY

SSD Drives warrants the goods against defects in design, materials and workmanship for the period of 12 months from the date of delivery on the terms detailed in SSD Drives Standard Conditions of Sale IA058393C.

SSD Drives reserves the right to change the content and product specification without notice.

# Safety Information



## Requirements

**IMPORTANT:** Please read this information BEFORE installing the equipment.

### Intended Users

This manual is to be made available to all persons who are required to install, configure or service equipment described herein, or any other associated operation.

The information given is intended to highlight safety issues, and to enable the user to obtain maximum benefit from the equipment.

Complete the following table for future reference detailing how the unit is to be installed and used.

INSTALLATION DETAILS	
Serial Number <i>(see product label)</i>	
Where installed <i>(for your own information)</i>	
Unit used as a: <i>(refer to Certification for the Inverter)</i>	<input type="checkbox"/> Component <input type="checkbox"/> Relevant Apparatus
Unit fitted:	<input type="checkbox"/> Wall-mounted <input type="checkbox"/> Enclosure

### Application Area

The equipment described is intended for industrial motor speed control utilising AC induction or AC synchronous machines.

### Personnel

Installation, operation and maintenance of the equipment should be carried out by qualified personnel. A qualified person is someone who is technically competent and familiar with all safety information and established safety practices; with the installation process, operation and maintenance of this equipment; and with all the hazards involved.

# Safety Information



## Hazards

### WARNING!

This equipment can endanger life through rotating machinery and high voltages. Failure to observe the following will constitute an ELECTRICAL SHOCK HAZARD. This is a product of the restricted sales distribution class according to IEC 61800-3. In a domestic environment this product may cause radio interference in which case the user may be required to take adequate measures. This product is designated as "professional equipment" as defined in EN61000-3-2. Permission of the supply authority shall be obtained before connection to the low voltage supply.

- The equipment must be **permanently earthed** due to the high earth leakage current.
- The drive motor must be connected to an appropriate safety earth.
- The equipment contains high value capacitors which take time to discharge after removal of the mains supply.
- Before working on the equipment, ensure isolation of the mains supply from terminals L1, L2 and L3. Wait for at least 3 minutes for the dc link terminals (DC+ and DC-) to discharge to safe voltage levels (<50V). Measure the DC+ and DC- terminal voltage with a meter to confirm that the voltage is less than 50V.
- Never perform high voltage resistance checks on the wiring without first disconnecting the drive from the circuit being tested.
- When replacing a drive in an application and before returning to use, it is essential that all user defined parameters for the product's operation are correctly installed.
- This equipment contains electrostatic discharge (ESD) sensitive parts. Observe static control precautions when handling, installing and servicing this product.

**IMPORTANT:** Metal parts may reach a temperature of 90 degrees centigrade in operation.

### Application Risk

The specifications, processes and circuitry described herein are for guidance only and may need to be adapted to the user's specific application. Refer to page 3-1.

SSD Drives does not guarantee the suitability of the equipment described in this Manual for individual applications.

### Risk Assessment

Under fault conditions, power loss or other operating conditions not intended, the equipment may not operate as specified. In particular:

- The motor speed may not be controlled
- The direction of rotation of the motor may not be controlled
- The motor may be energised

### Guards

The user must provide guarding and /or additional safety systems to prevent risk of injury and electric shock.

### Protective Insulation

- All control and signal terminals are SELV, i.e. protected by double insulation. Ensure all wiring is rated for the highest system voltage.

**Note:** Thermal sensors contained within the motor must be double insulated.

- All exposed metalwork in the Inverter is protected by basic insulation and bonding to a safety earth.

### RCDs

These are not recommended for use with this product but, where their use is mandatory, only Type B RCDs should be used.

# Contents

Contents

Page

## Chapter 1 GETTING STARTED

<b>Introduction</b> .....	<b>1-1</b>
Optional Equipment .....	1-1
<b>Equipment Inspection</b> .....	<b>1-2</b>
<b>About this Manual</b> .....	<b>1-2</b>
Initial Steps .....	1-2
How the Manual is Organised .....	1-2
• Application Block Diagrams .....	1-3
• Quick-Start Guide.....	1-3
• Information for Users without an Operator Station.....	1-3

## Chapter 2 AN OVERVIEW OF THE INVERTER

<b>Component Identification</b> .....	<b>2-1</b>
<b>Control Features</b> .....	<b>2-2</b>
<b>Understanding the Product Code</b> .....	<b>2-3</b>
<b>Functional Overview</b> .....	<b>2-4</b>
Power Board .....	2-4
Control Board.....	2-4
• Processor .....	2-4
• Technology Option Interface .....	2-4
• Operator Station Interface.....	2-4

## Chapter 3 INSTALLING THE INVERTER

<b>Mechanical Installation</b> .....	<b>3-1</b>
Mounting the Inverter .....	3-1
Minimum Air Clearances .....	3-1
• Ventilation .....	3-1
• Air Clearance: Cubicle-Mount Product/Application .....	3-3
• Air Clearance: Wall-Mount Product/Application.....	3-3
<b>Electrical Installation</b> .....	<b>3-4</b>
Wiring the Inverter .....	3-4
• Protective Earth (PE) Connections .....	3-6
• Power Wiring Connections .....	3-6
• Control Wiring Connections .....	3-7
<b>Optional Equipment</b> .....	<b>3-8</b>
• Fitting the Remote 6901 Operator Station .....	3-8
• Top Cover .....	3-9
• Technology Options.....	3-10
• External Brake Resistor .....	3-11
• External AC Supply EMC Filter .....	3-12

# Contents

<i>Contents</i>	<i>Page</i>
• Output Contactors .....	3-13
• Earth Fault Monitoring Systems .....	3-13
• Line Chokes (input) .....	3-14
• AC Motor Choke (output) .....	3-14

## **Chapter 4 OPERATING THE INVERTER**

<b>Pre-Operation Checks .....</b>	<b>4-1</b>
<b>Control Philosophy.....</b>	<b>4-2</b>
<b>Start/Stop and Speed Control.....</b>	<b>4-2</b>
• Selecting Local or Remote Control .....	4-3
<b>Start-up Routines .....</b>	<b>4-4</b>
Remote Control using Control Terminals (default set-up) .....	4-4
• Reading the Status LEDs .....	4-4
Local Control using the Operator Station .....	4-5
<b>Setting-up the Inverter .....</b>	<b>4-5</b>
Quick Set-up as an Open-loop Inverter (V/F fluxing) .....	4-5
Set-up using the Sensorless Vector Fluxing Mode .....	4-6
The Autotune Feature .....	4-6
Manual Tuning .....	4-7
• Tuning using the Motor Equivalent Circuit .....	4-7
• Tuning using a Simple Tuning Sequence .....	4-7
Tuning Difficulties.....	4-8
<b>The Start/Stop Mode Explained .....</b>	<b>4-8</b>
<b>Starting and Stopping Methods .....</b>	<b>4-9</b>
Normal Stopping Methods.....	4-9
• Ramp to Stop.....	4-9
• Coast to Stop.....	4-10
Advanced Stopping Methods .....	4-10
• Forced Fast Stop .....	4-10
• Forced Coast Stop .....	4-11
• The Trip Condition.....	4-11
• Logic Stopping.....	4-11
Normal Starting Method.....	4-12
Advanced Starting Methods .....	4-12
• Starting Several Inverters Simultaneously.....	4-12
• Single Wire Logic Starting.....	4-12
• Two Wire Logic Starting.....	4-13
• Three Wire Logic Starting .....	4-13

# Contents

Contents

Page

## Chapter 5 THE OPERATOR STATION

<b>Connecting the Operator Station .....</b>	<b>5-1</b>
• Welcome Screen .....	5-1
<b>Customising the Operator Station .....</b>	<b>5-1</b>
<b>Controlling the Drive using the Operator Station .....</b>	<b>5-2</b>
Control Keys .....	5-2
• Keys for Programming the Drive .....	5-2
• Keys for Operating the Drive Locally .....	5-2
LED Indications .....	5-3
<b>The Menu System .....</b>	<b>5-4</b>
Navigating the Menu System.....	5-4
• The Menu System Map .....	5-5
Changing a Parameter Value.....	5-6
What do the Symbols mean next to some Parameters?.....	5-6
• Parameter Status Information → ← = .....	5-6
• Expanded Menu Information >> .....	5-6
Alert Message Displays.....	5-7
The PROG Key .....	5-7
The L/R Key .....	5-7
<b>The MMI DIAGNOSTICS Menu .....</b>	<b>5-8</b>
<b>Special Menu Features .....</b>	<b>5-10</b>
Menu Shortcuts and Special Key Combinations.....	5-10
• Quick Link Information .....	5-10
• Quick Save to Memory.....	5-10
• Changing the Display Language.....	5-10
• Quick Drive Copy .....	5-10
• Changing the Product Code .....	5-11
• Quick Restore Default .....	5-11
Menu Viewing Levels .....	5-11
• Startup Screen Timeouts .....	5-11
Selecting the Display Language.....	5-12
Control Key Enable/Disable.....	5-12
Password Protection .....	5-12
• To Activate Password Protection .....	5-12
• To Deactivate Password Protection .....	5-12
Selecting Parameters for the Operator Menu .....	5-13
• Selecting a Startup Screen .....	5-13
• Customising the Welcome Screen .....	5-13
• Creating Custom Screens .....	5-14

# Contents

<i>Contents</i>	<i>Page</i>
<b>How to Save, Restore and Copy your Settings.....</b>	<b>5-14</b>
Saving Your Application .....	5-14
Restoring Saved Settings .....	5-14
Copying an Application .....	5-14
• Transferring Your Application to Another Inverter .....	5-14
• Backing-up Your Application .....	5-15
<b>Chapter 6 PROGRAMMING YOUR APPLICATION</b>	
<b>Introducing the Macro .....</b>	<b>6-1</b>
<b>Programming with Block Diagrams .....</b>	<b>6-1</b>
Modifying a Block Diagram .....	6-1
• Configuration and Parameterisation Modes .....	6-1
• Making and Breaking Links in Configuration Mode .....	6-1
• Programming Rules .....	6-2
• Execution Rules .....	6-2
• Saving Your Modifications .....	6-3
Understanding the Function Block Description .....	6-3
• MMI Menu Maps .....	6-3
Hexadecimal Representation of Trips.....	6-4
<b>Function Block Descriptions .....</b>	<b>6-5</b>
• ANALOG DIGIN.....	6-6
• ANALOG INPUT .....	6-8
• ANALOG OUTPUT .....	6-11
• AUTO RESTART.....	6-13
• AUTOTUNE.....	6-15
• BRAKE CONTROL.....	6-16
• COMMS CONTROL.....	6-17
• CURRENT FEEDBACK.....	6-18
• CURRENT LIMIT .....	6-20
• CUSTOM SCREEN .....	6-21
• DEMULTIPLEXER .....	6-23
• DIGITAL INPUT.....	6-24
• DIGITAL OUTPUT .....	6-25
• DYNAMIC BRAKING .....	6-26
• ENCODER.....	6-27
• FLUXING.....	6-28
• FLYCATCHING.....	6-30
• INJ BRAKING.....	6-32
• I/O TRIPS .....	6-33
• I*† TRIP .....	6-34
• JOG .....	6-35
• LOCAL CONTROL.....	6-36
• LOGIC FUNCTION .....	6-37
• MINIMUM SPEED.....	6-41
• MULTIPLEXER.....	6-42

# Contents

<i>Contents</i>	<i>Page</i>
• OPERATOR MENU .....	6-43
• OP STATION .....	6-44
• PASSWORD .....	6-46
• PATTERN GEN .....	6-47
• PID .....	6-48
• PRESET .....	6-50
• RAISE/LOWER .....	6-52
• REFERENCE .....	6-53
• SEQUENCING LOGIC .....	6-55
• SETPOINT SCALE .....	6-57
• SKIP FREQUENCIES .....	6-58
• SLEW RATE LIMIT .....	6-60
• SLIP COMP .....	6-61
• STABILISATION .....	6-62
• STALL TRIP .....	6-63
• STOP .....	6-64
• SYSTEM PORT (P3) .....	6-65
• SYSTEM RAMP .....	6-66
• TEC OPTION .....	6-68
• TRIPS HISTORY .....	6-69
• TRIPS STATUS .....	6-70
• UNDERLAP COMP .....	6-72
• VALUE FUNCTION .....	6-73
• VECTOR FLUXING .....	6-80
• VOLTAGE CONTROL .....	6-81
• ZERO SPEED .....	6-82
<b>Motor-Specific Parameters .....</b>	<b>6-83</b>
<b>Quadratic Torque Selection .....</b>	<b>6-84</b>

## **Chapter 7 TRIPS AND FAULT FINDING**

<b>Trips .....</b>	<b>7-1</b>
What Happens when a Trip Occurs .....	7-1
• Inverter Indications .....	7-1
• Operator Station Indications (when connected) .....	7-1
Resetting a Trip Condition .....	7-1
Using the Operator Station to Manage Trips .....	7-2
• Trip Messages .....	7-2
• Automatic Trip Reset .....	7-3
• Setting Trip Conditions .....	7-3
• Viewing Trip Conditions .....	7-3
Checksum Fail .....	7-4
• Inverter Indications .....	7-4
• Operator Station Indications (when connected) .....	7-4
<b>Fault Finding .....</b>	<b>7-4</b>

# Contents

Contents

Page

## Chapter 8 ROUTINE MAINTENANCE AND REPAIR

<b>Routine Maintenance</b> .....	<b>8-1</b>
<b>Repair</b> .....	<b>8-1</b>
Saving Your Application Data .....	8-1
Returning the Unit to SSD Drives .....	8-1
Disposal .....	8-1

## Chapter 9 SEQUENCING LOGIC

<b>Principle State Machine</b> .....	<b>9-1</b>
Main Sequencing States.....	9-1
State Outputs of the SEQUENCING LOGIC Function Block .....	9-1
Transition of States .....	9-2
State Diagram .....	9-3
<b>External Control of the Inverter</b> .....	<b>9-4</b>
Communications Command.....	9-4
• Example Commands .....	9-5
Communications Status .....	9-6

## Chapter 10 PARAMETER SPECIFICATION

<b>Specification Table: Tag Number Order</b> .....	<b>10-2</b>
<b>Product-Related Default Values</b> .....	<b>10-19</b>
• Language Dependant Defaults .....	10-19
• AC Supply Voltage and Power Rating Dependant Defaults .....	10-20

## Chapter 11 TECHNICAL SPECIFICATIONS

605C Model Recognition .....	11-1
Environmental Details.....	11-1
Earthing/Safety Details .....	11-2
Terminal Block Wire Sizes .....	11-2
Electrical Ratings .....	11-3
Cabling Requirements for EMC Compliance .....	11-4
EMC Compliance.....	11-4
External AC Supply (RFI) Filters.....	11-4
Internal Dynamic Brake Switch .....	11-5
Control Terminals .....	11-6
Analog Inputs/Outputs .....	11-7
Digital Inputs .....	11-7
Digital Outputs .....	11-7
Supply Harmonic Analysis.....	11-8

# Contents

## Chapter 12 CERTIFICATION FOR THE INVERTER

<b>Requirements for EMC Compliance .....</b>	<b>12-1</b>
Minimising Radiated Emissions .....	12-1
Earthing Requirements.....	12-1
• Protective Earth (PE) Connections .....	12-1
• EMC Earth Connections .....	12-1
Cabling Requirements .....	12-2
• Planning Cable Runs.....	12-2
• Increasing Motor Cable Length.....	12-2
EMC Installation Options.....	12-3
• Screening & Earthing (wall mounted, Class A) .....	12-3
• Screening & Earthing (cubicle mounted, Class B) .....	12-3
• Star Point Earthing .....	12-5
• Sensitive Equipment .....	12-6
<b>Requirements for UL Compliance .....</b>	<b>12-7</b>
• Solid-State Motor Overload Protection .....	12-7
• Short Circuit Rating .....	12-7
• Solid-State Short-Circuit Protection.....	12-7
• Recommended Branch Circuit Protection.....	12-7
• Motor Base Frequency.....	12-7
• Field Wiring Temperature Rating .....	12-7
• Field Wiring Terminal Markings.....	12-7
• Power Wiring Terminals .....	12-7
• Terminal Tightening Torque .....	12-7
• Field Grounding Terminals.....	12-8
• Operating Ambient Temperature .....	12-8
• Direct Wall-Mountable Models .....	12-8
<b>European Directives and the CE Mark.....</b>	<b>12-9</b>
CE Marking for Low Voltage Directive .....	12-9
CE Marking for EMC - Who is Responsible? .....	12-9
• Legal Requirements for CE Marking.....	12-10
• Applying for CE Marking for EMC.....	12-10
Which Standards Apply?.....	12-10
• Power Drive Product Specific or Generic Standards.....	12-10
Certificates .....	12-16

# Contents

---

Contents

Page

## Chapter 13 APPLICATION NOTES

<b>Synchronous Motor Control .....</b>	<b>13-1</b>
<b>Brake Motors .....</b>	<b>13-1</b>
<b>Using Line Chokes .....</b>	<b>13-2</b>
<b>Using Output Contactors.....</b>	<b>13-2</b>
<b>Using Motor Chokes .....</b>	<b>13-2</b>
<b>Using Multiple Motors on a Single Drive.....</b>	<b>13-3</b>
<b>Dynamic Braking .....</b>	<b>13-3</b>
Brake Resistor Selection .....	13-4
<b>High Starting Torque .....</b>	<b>13-5</b>

## Chapter 14 SERIAL COMMUNICATIONS

<b>Communications Technology Option .....</b>	<b>14-1</b>
ConfigEd Lite .....	14-1
<b>Connection to the P3 Port .....</b>	<b>14-1</b>

## Chapter 15 APPLICATION MACROS

<b>The Default Application .....</b>	<b>15-1</b>
<b>How to Load a Macro.....</b>	<b>15-1</b>
<b>Macro Descriptions .....</b>	<b>15-1</b>
Macro 0 .....	15-1
Macro 1: Basic Speed Control (default) .....	15-3
Macro 2: Run Forward/Run Reverse .....	15-5
Macro 3: Raise/Lower Trim.....	15-7
Macro 4: Process PID .....	15-9
Macro 5: Preset Speeds .....	15-11
Macro 6: Closed-Loop Speed Feedback .....	15-13
Macro 99: 584S Compatible Application .....	15-15
General Wiring Diagram for Macro 99 .....	15-18
Macro Control Blocks .....	15-19
Macro User Blocks .....	15-20

# GETTING STARTED

## Introduction

The 605C Frequency Inverter is designed for speed control of standard 3-phase induction motors. It is available in a range of ratings for constant torque and quadratic torque applications. This dual mode feature is available on all 605C models and provides a cost effective solution to general industrial applications, as well as the control of pumps and fans.

- The unit can be controlled remotely using configurable analog and digital inputs and outputs, requiring no optional equipment.
- Controlling the unit locally using the 6051 Operator Station, or remotely using ConfigEd Lite (or other suitable PC programming tool) and the Technology Options, gives access to parameters, diagnostic messages, trip settings and full application programming. Other features also become available, such as the advanced sensorless vector control scheme which gives high torque, low speed operation; selectable switching frequencies; and a unique Quiet Pattern control system that minimises audible noise from the motor.

Technology Options can be fitted to the Inverter to give serial communications, closed loop speed control, and the factory-fitted dynamic braking functions.

**IMPORTANT:** Motors used must be suitable for inverter duty.

## Optional Equipment

Item	Part Number
6051 Operator Station <i>A plug-in unit providing control, monitoring and programming capabilities</i>	6051
Panel Mounting Kit for the 6051 Operator Station	6052
TB1 Comms Technology Option <i>This is a plug-in unit. Versions are available to provide Link2, Profibus, Devicenet or RS422/485 serial comms. Refer to SSD Drives for available protocols.</i>	6055/option
TB2 Speed Feedback Technology Option <i>This is a plug-in unit. It provides speed feedback plus RS422 re-transmit. Feedback options are TTL Encoder (RS422), HTL Encoder (15V), Analog Tach, Sinusoidal Encoder, Resolver, Microtach.</i>	6054/option
External Brake Resistor <i>A standard heat resistor.</i>	CZ463068 CZ388396
External AC Supply (RFI) Filter	Refer to Chapter 11: "External AC Supply (RFI) Filters" for Part Numbers
Top Cover (UL Type 1 / IP4x) <i>A protective cover fitted to wall-mounted units to give improved compliance ratings</i>	B0470230U007 (top) FB038K12 (screw)
ConfigEd Lite <i>SSD Drives' Windows-based block programming software</i>	Order by name
EMC Installation Guidelines for Modules and Systems <i>A SSD Drives application manual detailing EMC requirements</i>	HA388879

**Table 1-1 Optional Equipment**

## Equipment Inspection

---

- Check for signs of transit damage
- Check the product code on the rating label conforms to your requirement.

If the unit is not being installed immediately, store the unit in a well-ventilated place away from high temperatures, humidity, dust, or metal particles.

Refer to Chapter 2: “An Overview of the Inverter” to check the rating label/product code.  
Refer to Chapter 8: “Routine Maintenance and Repair” for information on returning damaged goods.

## About this Manual

---

This manual is intended for use by the installer, user and programmer of the 605C Inverter. It assumes a reasonable level of understanding in these three disciplines.

**Note:** *Please read all Safety Information before proceeding with the installation and operation of this unit.*

Enter the “Model No” from the rating label into the table at the front of this manual. There is also a column for you to record your application’s parameter settings in the table in Chapter 10. It is important that you pass this manual on to any new user of this unit.

## Initial Steps

Use the manual to help you plan the following:

### **Installation**

Know your requirements:

- certification requirements, EMC/UL conformance
- wall-mount or enclosure?
- conformance with local installation requirements
- supply and cabling requirements

### **Operation**

Know your operator:

- how is it to be operated, local and/or remote?
- what level of user is going to operate the unit?
- decide on the best menu level for the Operator Station

### **Programming (Operator Station or suitable PC programming tool only)**

Know your application:

- install the most appropriate macro
- plan your “block diagram programming”
- enter a password to guard against illicit or accidental changes
- learn how to back-up your application data
- customise the Operator Station to the application

## How the Manual is Organised

The manual is divided into chapters and paragraphs. Page numbering restarts with every chapter, i.e. 5-3 is Chapter 5, page 3.

This manual describes the 605C Inverter.

## Application Block Diagrams

You will find these at the rear of the manual. The pages unfold to show a complete block diagram, these will become your programming tool as you become more familiar with the 605's software.

## Quick-Start Guide

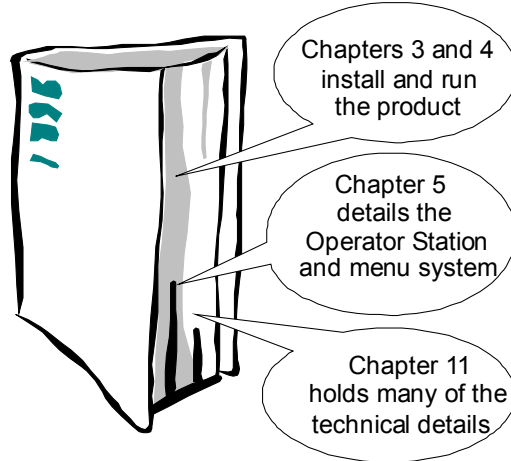

DEFAULT

## Information for Users without an Operator Station

This symbol identifies important text for users operating the 605C Inverter using the default (factory) set-up.

If the text is italic, *such as this*, then the information is especially for users without the Operator Station or suitable PC programming tool.

# 1-4 Getting Started

# AN OVERVIEW OF THE INVERTER

## Component Identification

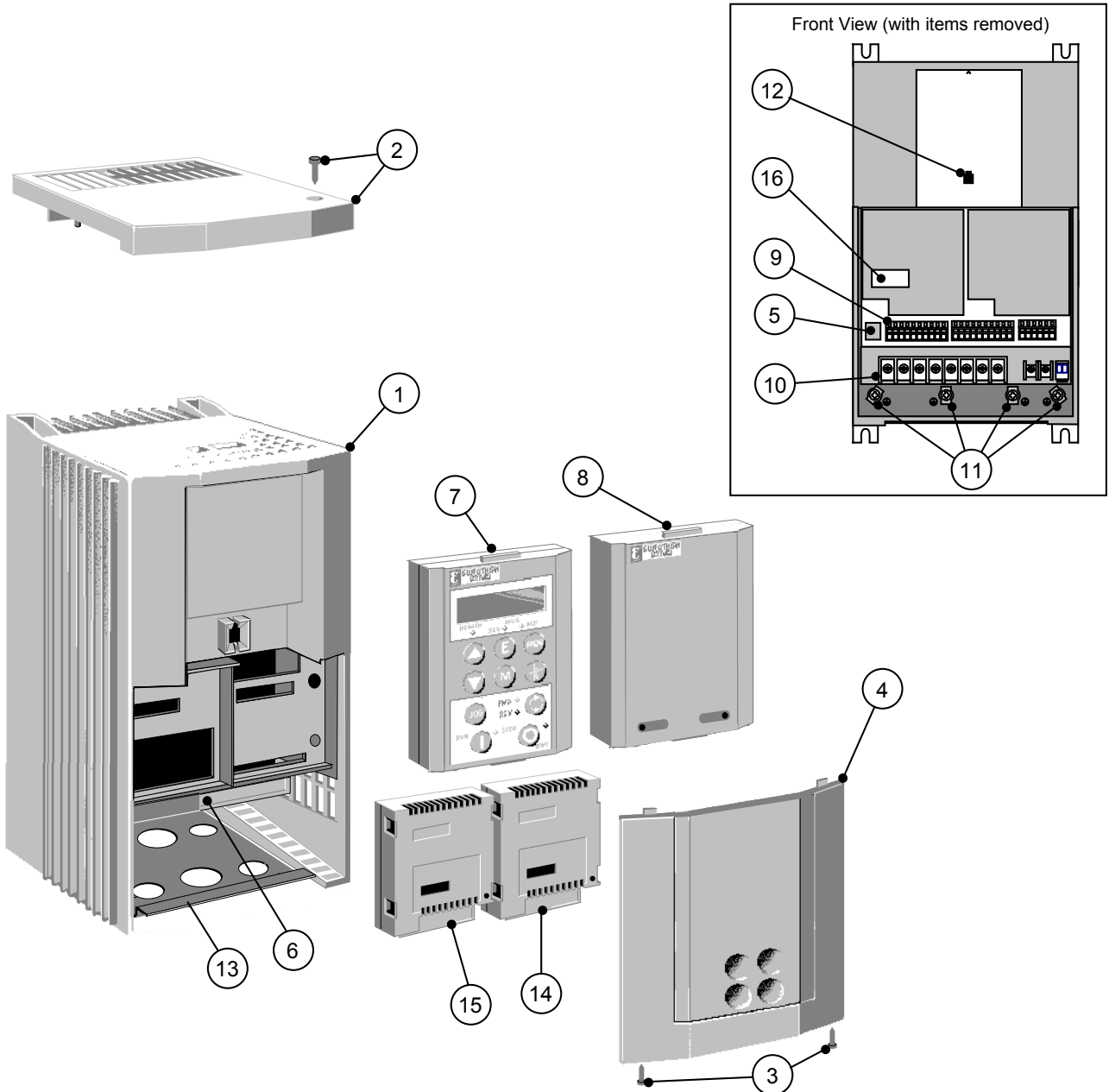

Figure 2-1 View of Component Parts

<b>1</b>	Main inverter assembly	<b>9</b>	Control terminals
<b>2</b>	Top cover and screw (optional)	<b>10</b>	Power terminals
<b>3</b>	Terminal cover retaining screw	<b>11</b>	Earthing points
<b>4</b>	Terminal cover	<b>12</b>	RS232 programming port
<b>5</b>	Remote operator station port	<b>13</b>	Gland plate
<b>6</b>	Power terminal shield	<b>14</b>	Comms technology option (optional)
<b>7</b>	6051 operator station (optional)	<b>15</b>	Speed feedback technology option (optional)
<b>8</b>	Blank cover	<b>16</b>	Configuration switches SW1 & SW2

## 2-2 An Overview of the Inverter

### Control Features

The 605C Inverter is fully-featured when controlled using the optional Operator Station (or a suitable PC programming tool).

DEFAULT

*The 'General' control features below are not available when the unit is controlled using the analog and digital inputs and outputs.*

<b>General</b>	Output Frequency	Selectable 0-120Hz, 240Hz or 480Hz
	Switching Frequency	Constant Torque: selectable 3kHz or 6kHz depending on power rating Quadratic Torque: 3kHz for all units
	Voltage Boost	0-25% (Fixed or Auto Boost)
	Flux Control	1. V/F control with linear or fan law profile 2. Sensorless vector with automatic flux control and slip compensation
	Slip Compensation	Compensates for motor slip for varying loads
	Skip Frequencies	4 skip frequencies with adjustable skip band width
	Preset Speeds	8 presets with programmable ramp rates
	Stopping Modes	Ramp, ramp with hold, coast, dc injection, fast stop
	Ramps	Symmetric or asymmetric ramp up and down rates
	Raise/Lower	Programmable MOP function
	Jog	Programmable jog speed
	Logic Functions	10 programmable 3 input logic function blocks performing NOT, AND, NAND, OR, NOR and XOR functions
	Value Functions	10 programmable 3 input value function blocks performing IF, ABS, SWITCH, RATIO, ADD, SUB, RATIO, TRACK/HOLD, and BINARY DECODE functions
	Diagnostics	Full diagnostic and monitoring facilities
<b>Protection</b>	Trip Conditions	Output short line to line, and line to earth Overcurrent > 220% I x t overload 50-105% (adjustable) Heatsink overtemperature Motor Thermistor overtemperature Overvoltage and undervoltage
	Current Limits	Adjustable 50%-150% 180% shock load limit
	Voltage/ Frequency Profile	Constant torque Fan Law
<b>Inputs/ Outputs</b>	Analog Inputs	4 user-configurable: Speed setpoint/trim $\pm 10V$ , 0-10V, 2-10V, 0-5V, 1-5V Speed setpoint 4-20, 20-4, 0-20 or 20-0mA Current loop 4-20, 20-4, 0-20 or 20-0mA Torque limit 0-10V
	Analog Outputs	2 user-configurable: Speed 0-10V and 0-20mA Load $\pm 10V$
	Digital Inputs	8 x 24V dc inputs (user-configurable)
	Digital Outputs	3 relay contacts (volt-free)

**Table 2-1 Control Features**

## Understanding the Product Code

The 605C unit is fully identified using a ten block alphanumeric code which records how the Inverter was calibrated, and its various settings when despatched from the factory.

The Product Code appears as the “Model No.”. Each block of the Product Code is identified as below:

 Model No: 605C/0075/400/0021/UK/RS485/PROF/B1/0/0 Serial No: S2345699987803 Fax: +44-(0)1903 723938	Type 1 Enclosure		Input Output	380-460 0.380-460	3ph AC V 50/60Hz 3ph AC V 0..480Hz
	Torque Constant Quadratic		Input Output	22.0 16.0	28.0 23.0
WARNING: Read product manual for Installation and Safety Information. Type B RCD protection devices only. Permanent protective earth mandatory.			  LISTED Industrial Control Equipment Class 55Y4 File No: E142140		

**Note:** The Language field controls the default setting for the *BASE FREQUENCY* parameter.

Block No.	Variable	Description
1	605C	Generic product
2	XXXX	Four numbers specifying the power output, for example: 0055 = 5.5kW 0075 = 7.5kW 0110 = 11kW
3	XXX	Three numbers specifying the nominal input voltage rating: 400 380 to 460V (±10%) 50/60Hz 500 500V (±10%) 50/60Hz
4	XXXX	Four digits specifying the mechanical package including livery and mechanical package style: First two digits Livery 00 Standard SSD Drives livery 01-99 Defined customer liveries Third digit Mechanical packaging style 1 Standard (IP20), protected panel mounting 2 IP20 and falling dirt protection (UL Type 1) wall mounting Fourth digit Operator Station 0 No Operator Station 1 6051 Operator Station option fitted
5	XX	Two characters specifying the user interface language. These characters are the same as used for computer keyboard specifications: UK English (50Hz) US United States (English + 60Hz) GR German (50Hz) FR French (50Hz) SP Spanish (50Hz) P5 P Language (50Hz) P6 P Language (60Hz)
6	XXX	Three characters specifying the speed feedback option, 6054 (Technology Option 1), installed over and above the standard features of the product: 0 No additional option fitted RS422 Wire ended encoder feedback RS422 HTTL Wire ended encoder feedback HTTL
7	XXXX	Four characters specifying the communications option protocol, 6055 (Technology Option 2), and its hardware implementation method: 0 No technology option fitted EI00 EI ASCII/Bisync with hardware implementation 1 (RS485/422) PROF Profibus protocol LINK LINK protocol

## 2-4 An Overview of the Inverter

Block No.	Variable	Description
8	XX	Two characters specifying the braking option: B0 Brake power switch fitted - no braking resistors supplied Note: External braking resistors should be specified and ordered separately.
9	XXX	Three characters specifying the auxiliary mains power supply. 0 Reserved
10	XXX	3 digits specifying engineering special options: 0 No special option

## Functional Overview

---

### Power Board

DC link capacitors smooth the dc voltage output prior to the Inverter power stage. The IGBT (Insulated Gate Bi-polar Transistor) output stage converts the dc input to a three phase output used to drive the motor.

### Control Board

#### Processor

The processor provides for a range of analog and digital inputs and outputs, together with their reference supplies. For further details refer to Chapter 11: “Technical Specifications” - Control Terminals.

DEFAULT

The I/O configuration switches (SW1 & SW2) on the control board can be seen when the terminal cover and the left-hand Technology Option is removed. These switches configure the analog i/o terminals. Refer to Chapter 6: “Programming Your Application” - ANALOG INPUT and ANALOG OUTPUT.

#### Technology Option Interface

This is a multi-way connector and processor bus with control signals allowing Speed Feedback and Communications Technology Options to be fitted to the 605C Inverter.

#### Operator Station Interface

This is a non-isolated RS232 serial link for communication with the Operator Station. Alternatively, a PC running SSD Drives’ “ConfigEd Lite” Windows-based configuration software (or some other suitable PC programming tool) can be used to graphically program and configure the 605C Inverter.

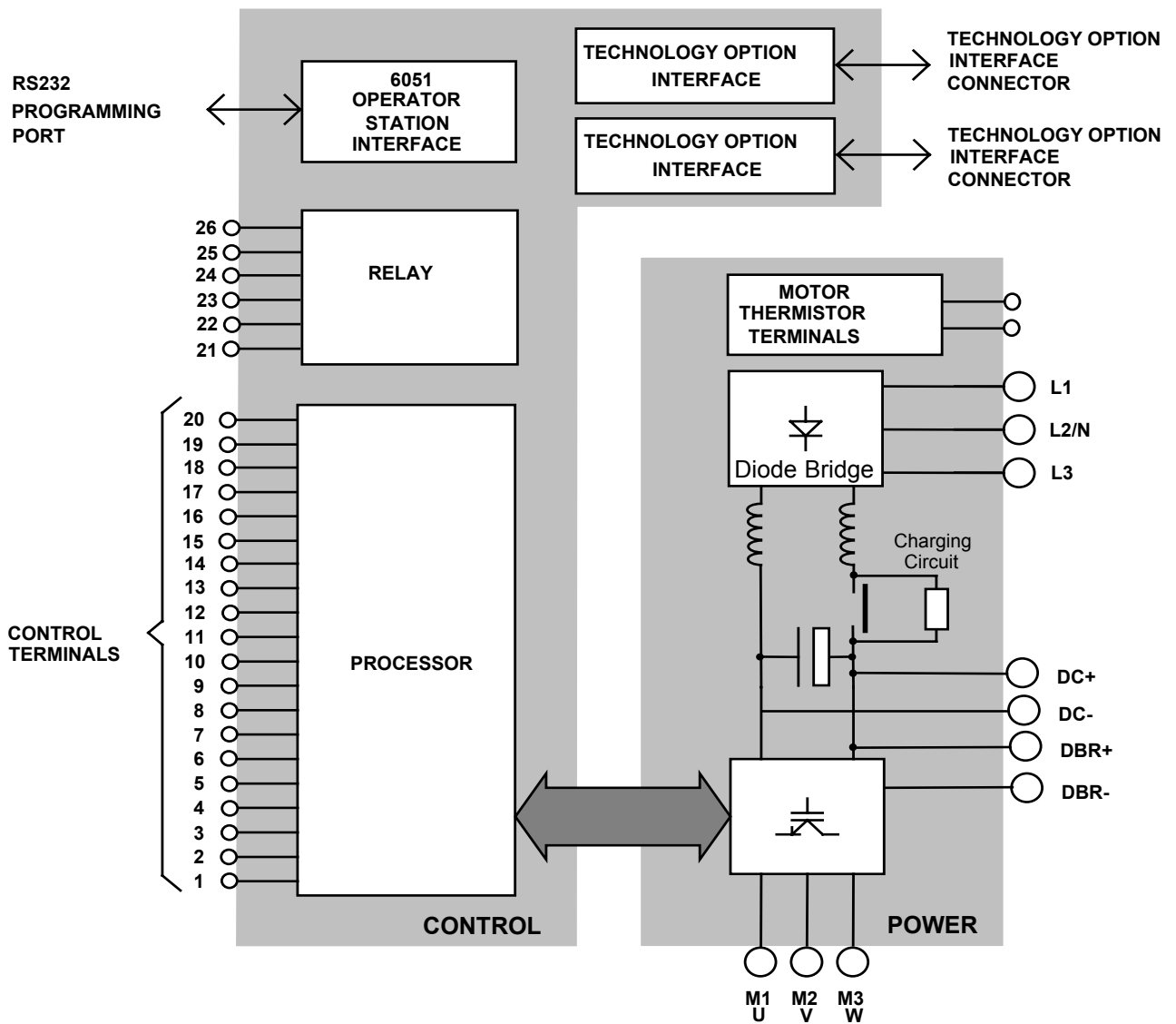

Figure 2-2 Functional Block Diagram

## 2-6 An Overview of the Inverter

# INSTALLING THE INVERTER

**IMPORTANT:** Read Chapter 12: “Certification for the Inverter” before installing this unit.

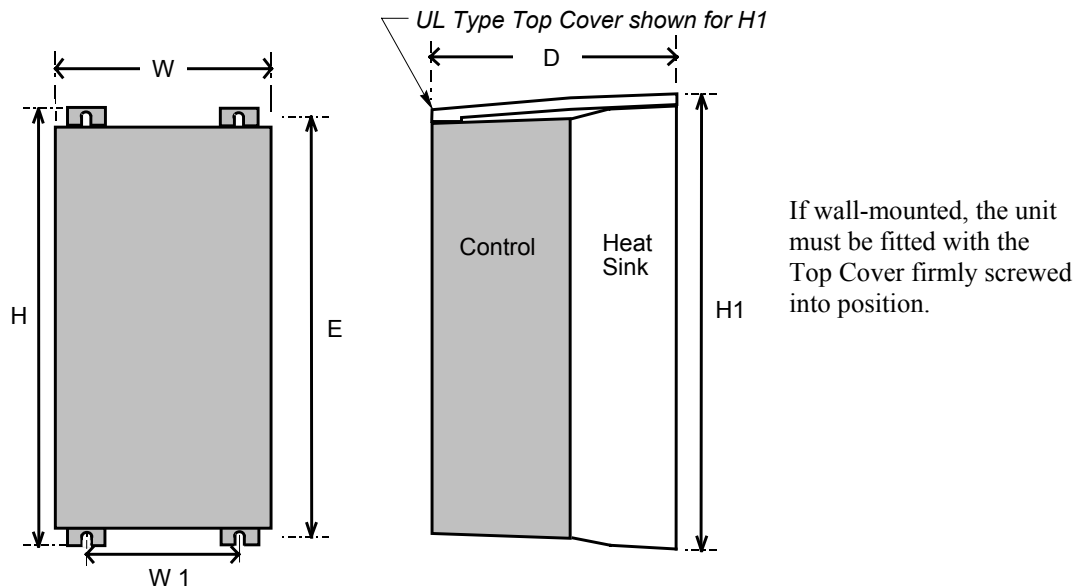

Figure 3-1 Mechanical Dimensions for 605C

## Mechanical Installation

Model Recognition Product Code (Blocks 2 & 3)	Weight lbs/kg	H all models	H1 all models	W all models	W1 all models	D all models	E all models	Fixings all models
0055/400	17.4/7.9	348.0 (13.70)	365.0 (14.37)	201.0 (7.91)	150 (5.90)	208.0 (8.19)	335.0 (13.19)	Slot 7mm wide. Use M5 or M6 fixings.
0075/400	20.2/9.2							
0110/400	20.5/9.3							
0055/500	17.4/7.9							
0075/500	20.2/9.2							
0110/500	20.5/9.3							
All dimensions are in millimetres (inches)								

**Note:** Details of a through-panel mounting option for dirty air cooling are available from SSD Drives.

### Mounting the Inverter

The unit must be mounted vertically on a solid, flat, vertical surface. It can be wall-mounted, or mounted inside a suitable cubicle, depending upon the required level of EMC compliance - refer to Chapter 11: “Technical Specifications” and Chapter 12: “Certification for the Inverter”.

### Minimum Air Clearances

#### Ventilation

The inverter gives off heat in normal operation and must therefore be mounted to allow the free flow of air through the ventilation slots and heatsink. Maintain minimum clearances for ventilation as given in the tables below to ensure adequate cooling of the Inverter, and heat generated by other adjacent equipment is not transmitted to the Inverter. Be aware that other

## 3-2 Installing the Inverter

equipment may have its own clearance requirements. When mounting two or more 605s together, these clearances are additive.

Ensure that the mounting surface is normally cool.

## Air Clearance: Cubicle-Mount Product/Application

(Europe: IP2x, USA/Canada: Open Type).

The Inverter, without the top cover fitted, must be mounted in a suitable cubicle.

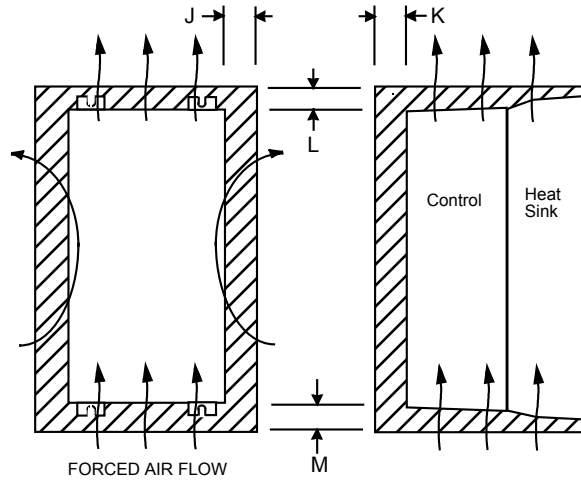

**Figure 3-2 Air Clearance for a Cubicle-Mount Product/Application**

Model Recognition	Clearances for Standard Product without UL Type 1 Top Cover (mm)			
	J	K	L	M
All models	15	0 (zero)	70	70

## Air Clearance: Wall-Mount Product/Application

(Europe: IP2x plus IP4x top surface protection, USA/Canada: Type 1).

Wall-mounted 605s **must** have the top cover correctly fitted. The top cover fixing screw has a maximum tightening torque of 1.5Nm (1.2Nm recommended).

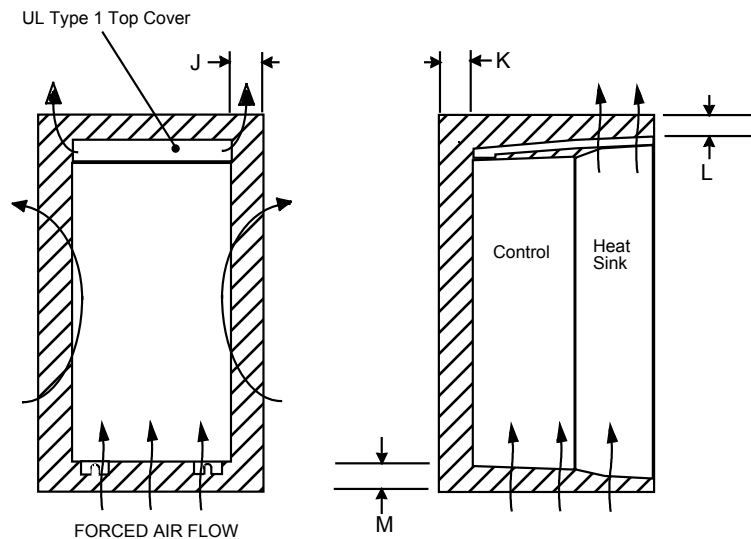

**Figure 3-3 Air Clearance for a Wall-Mount Product/Application**

Model Recognition	Clearances for Standard Product with UL Type 1 Top Cover (mm)			
	J	K	L	M
All models	20	0 (zero)	70	70

# 3-4 Installing the Inverter

## Electrical Installation

**IMPORTANT:** Please read the Safety Information on page Cont. 3 & 4 before proceeding.

### Wiring the Inverter

#### WARNING!

Ensure that all wiring is electrically isolated and cannot be made "live" unintentionally by other personnel.

**Note:** Refer to Chapter 11: "Technical Specifications" for additional Cabling Requirements and Terminal Block Wire Sizes.

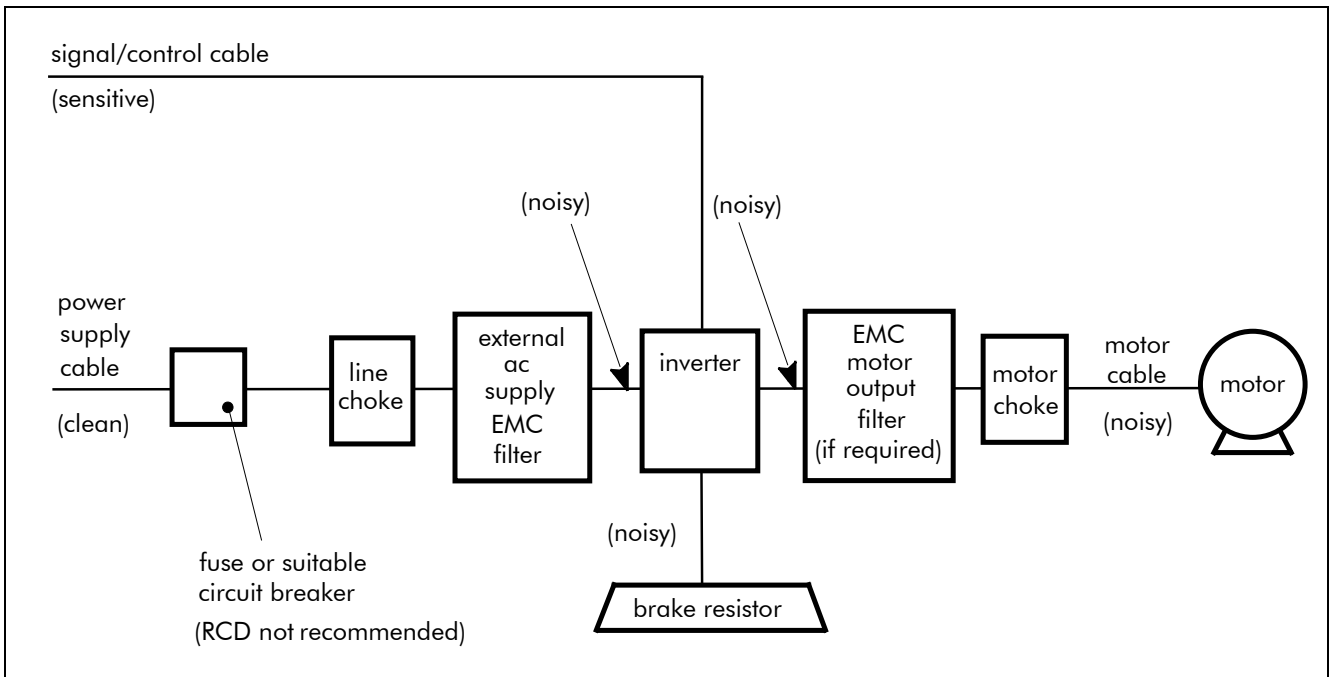

Figure 3-4 Cabling Requirements

Cables are considered to be electrically *sensitive*, *clean* or *noisy*. You should already have planned your cable routes with respect to segregating these cables for EMC compliance. If not, refer to Chapter 12: "Certification for the Inverter".

### Cable Gland Requirements

Use a metal gland to connect to the internally earthed gland plate. It must be capable of securing a 360 degree screened connection to give EMC compliance. A 360 degree screened connection can be achieved as shown.

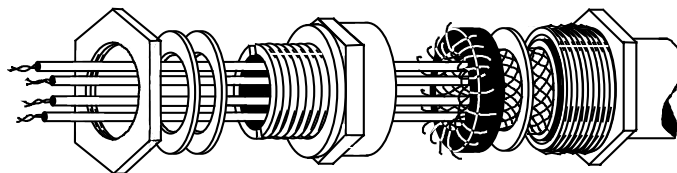
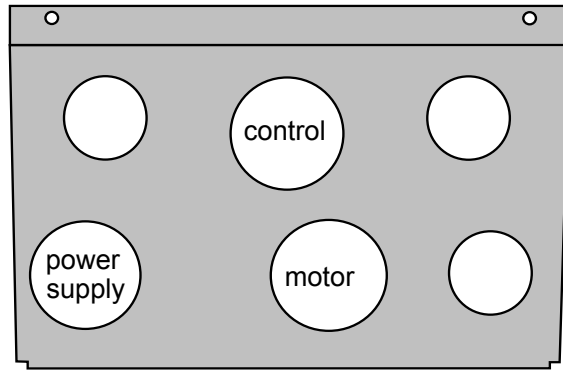

Figure 3-5 360 Degree Screened Connection

The receiving hole in the gland plate has a compromised diameter of 28.6mm to accept metric M20, PG16 and American 1/2" NPT cable gland sizes.



3 x 28.6mm diameter, 3 x 22.8mm diameter

**Figure 3-6 Cable and Screen Fixings showing recommended usage of Gland Plate**

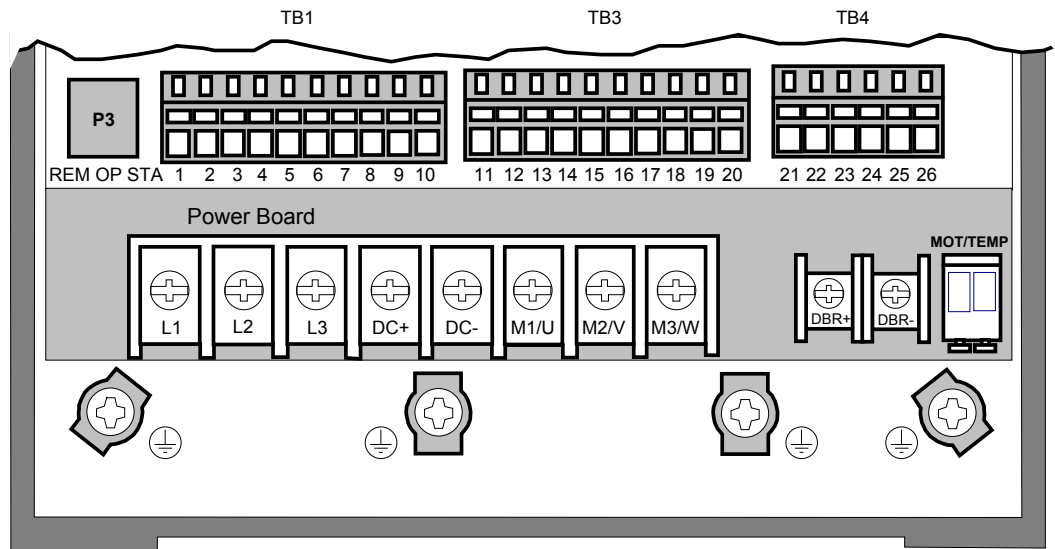

**Figure 3-7 605C Inverter showing Earth, Power and Control Board Terminals**

## 3-6 Installing the Inverter

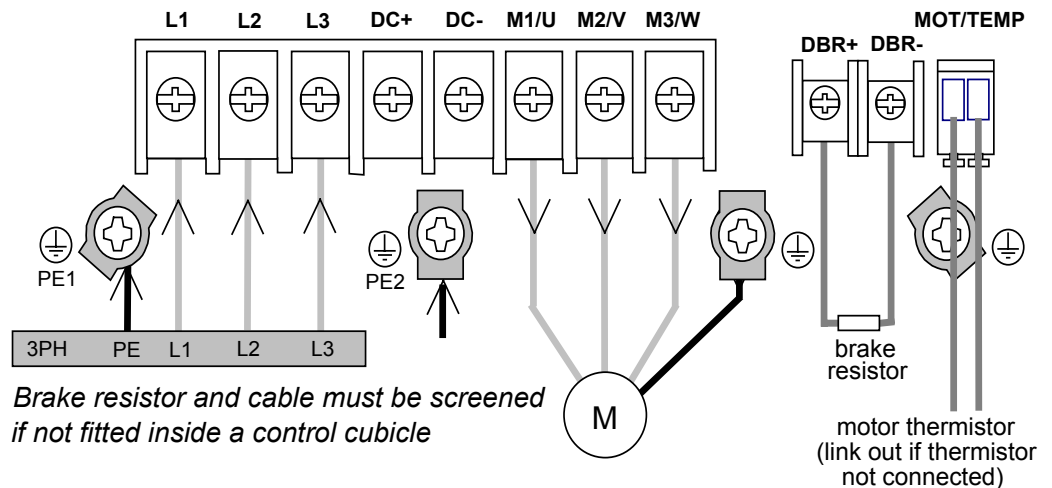

Figure 3-8 Earth and Power Wiring Connections for Three Phase Input

### Protective Earth (PE) Connections

**IMPORTANT:** The unit must be permanently earthed. Each conductor used for permanent earthing must *individually* meet the requirements for a protective earth conductor.

For installations to EN 60204 in Europe:

- for permanent earthing, two individual incoming protective earth conductors (<math><10\text{mm}^2</math> cross-section) or one conductor (>math>>10\text{mm}^2</math> cross-section) are required.

Protect the incoming mains supply as shown in Chapter 11: “Technical Specifications” - Power Details, using a suitable fuse or circuit breaker (a circuit breaker, e.g. RCD, ELCB, GFCI, is not recommended, refer to “Earth Fault Monitoring Systems”, page 3-13).

**IMPORTANT:** The Inverter fitted with an external ac supply EMC filter is only suitable for earth referenced supplies (TN). The Inverter requires two individual incoming protective earth conductors to the filter when fitted, refer to Chapter 12: “Certification for the Inverter” - EMC Installation Options.

### Power Wiring Connections

1. Remove the terminal cover retaining screws and lift off the terminal cover.
2. Lift the internal power terminal shield.
3. Feed the power supply and motor cables into the inverter through the metal gland plate using the correct cable entries, and connect to the power terminals. Tighten the terminals to a torque of 1.0Nm (9 in.lb). Refer to Figure 3-8 above.
4. Lower the internal power terminal shield.

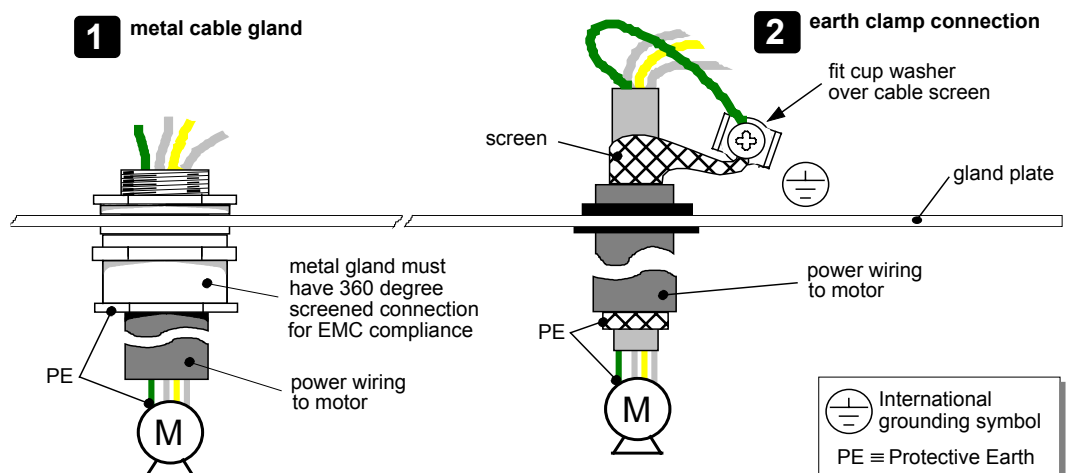

## Control Wiring Connections

**Note:** Use screened control cables to comply with EMC requirements.

1. Feed the control cables into the inverter through the metal gland plate and connect to the control terminals. The diagram below shows the typical control connections required for operation as a simple speed controller.
2. Refit and secure the terminal cover using the retaining screws.

**Note:** Refer to Chapter 11: "Technical Specifications" for Control Terminal information  
 Refer to Chapter 6: "Programming Your Application" for ANALOG INPUT and ANALOG OUTPUT 1 configuration switch settings.

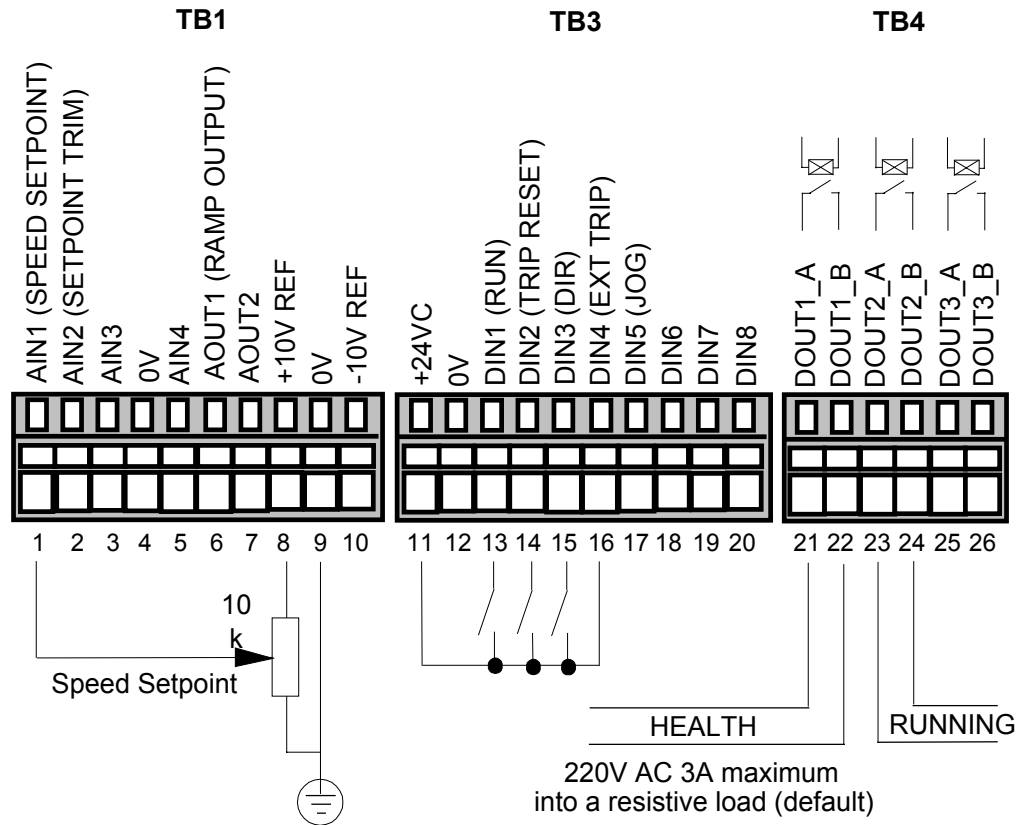

**Figure 3-9 Typical Connection to the Control Terminals (as Macro 1)**

# 3-8 Installing the Inverter

## Optional Equipment



### Fitting the Remote 6901 Operator Station

The 6052 Mounting Kit is required to remote-mount a 6901 Operator Station. It is possible to:

- Remote-mount the drive-mounted Operator Station using the port(s) illustrated
- Remote-mount an additional Operator Station in the lower port (not Frame B) - in this case, both Operator Stations are fully functional
- Remote-mount both Operator Stations as illustrated (not Frame B) - in this case, both Operator Stations are fully functional

You can also replace any Operator Station for a PC running ConfigEd Lite (or other suitable PC programming tool) in all of the options above.

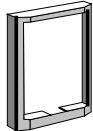
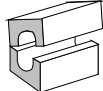
### 6052 Mounting Kit Parts for the Remote Keypad

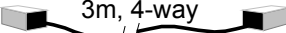
6052 Mounting Kit Tools required : No. 2 Posidrive screwdriver					
1		1		1	 Steward 28A2025-OAO
4	 No. 6 x 12mm	1	 3m, 4-way		

### Assembly Procedure

Remove the factory-fitted P3 lead from the P3 port under the terminal cover which connects the fitted Operator Station. Fit the ferrite to one end of the 3m connector lead, passing the cable through the ferrite twice as shown below. Plug the 3m connector lead from the remote-mounted Operator Station into the P3 port (see the diagram on the previous page) ensuring that the ferrite is at the drive end of the lead and is as close to the drive as possible.

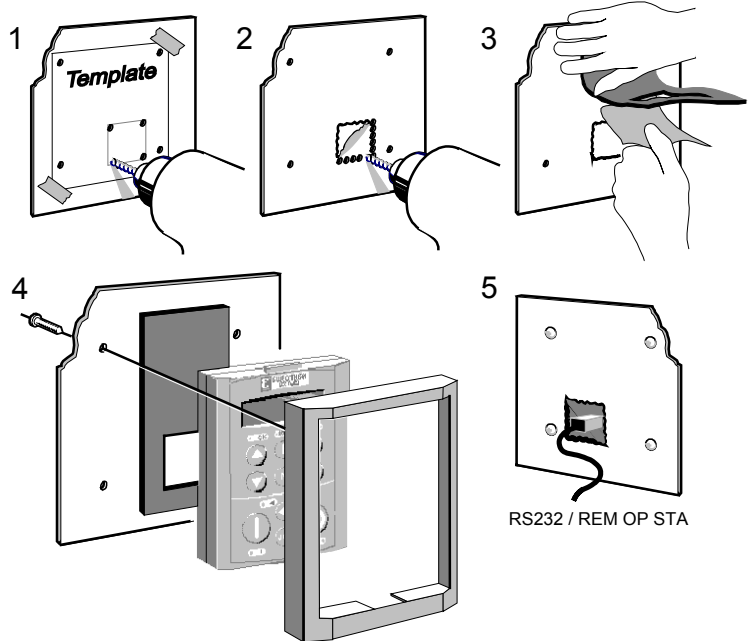

## Cutout Dimensions

An actual size template is also provided with the Operator Station/6052 Mounting Kit.

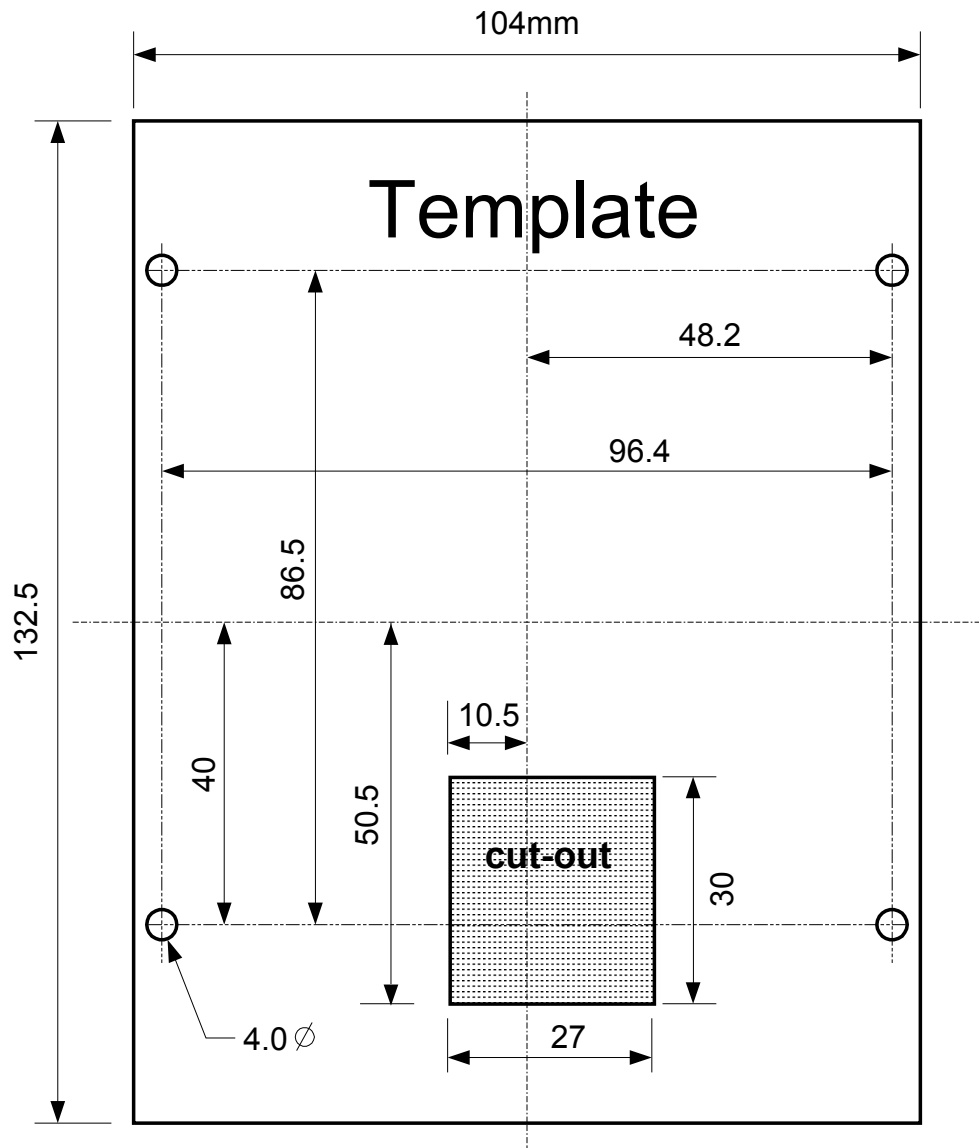

**Figure 3-10 Mounting Dimensions for the Remote-Mounted Keypad 6901**

## Top Cover

This UL Type 1 top cover is fitted to wall-mounted 605C units to give improved compliance ratings. Refer to Chapter 11: “Technical Specifications” - Environmental Details.

Align the top cover to be flush with the front of the unit and press the locating pegs firmly into position. The top must be secured with a screw.

# 3-10 Installing the Inverter

## Technology Options

There are two Technology Options:

1. Speed Feedback (6054)
2. Communications (6055)

They are plugged into the two positions, as illustrated.

You can operate the Inverter with the Speed Feedback and/or Communications Technology Options, but you **cannot** use two options of the same kind.

Refer to the appropriate Technology Option Technical Manual for further information.

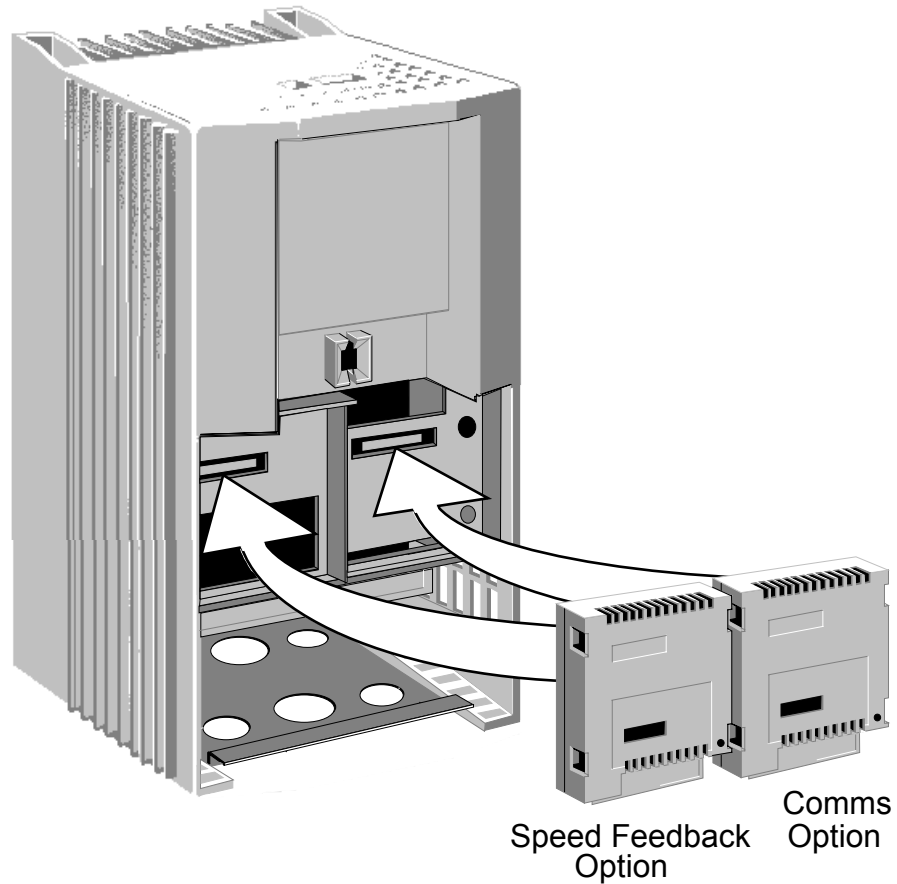

### Removal

Remove the option by carefully pushing a long screwdriver (for instance) under the option and gently prising it out. The pins are protected by the option moulding.

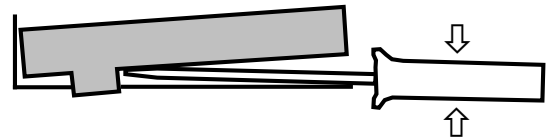

### **WARNING!**

Isolate the drive before fitting or removing the option.

## External Brake Resistor

Two standard heat resistors are available from SSD Drives. These resistors should be mounted on a heatsink (back panel) and covered to prevent injury from burning.

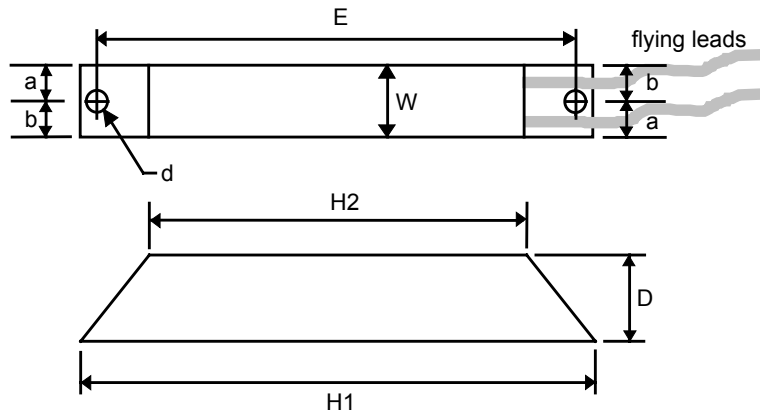

**Figure 3-11**  
**Brake Resistor**  
**Outline Dimensions**  
**(mm)**

Part number	CZ463068	CZ388396
Dimensions H1 (mm)	165	335
H2 (mm)	125	295
E (mm)	146	316
D (mm)	60	60
W (mm)	30	30
a (mm)	13	13
b (mm)	17	17
d (mm - diameter)	5.3	5.3
Flying lead length (mm)	500	500
Electrical Connection	M5 spade	M5 ring

**Table 3-1 Brake Resistor Dimensions**

Part Number	CZ389853	CZ463068
Resistance	100Ω	56Ω
Max wattage	100W	200W
5 second rating	500%	500%
3 second rating	833%	833%
1 second rating	2500%	2500%
Electrical connection	M4 spade	M5 spade

**Table 3-2 Braking Resistor Details**

# 3-12 Installing the Inverter

## External AC Supply EMC Filter

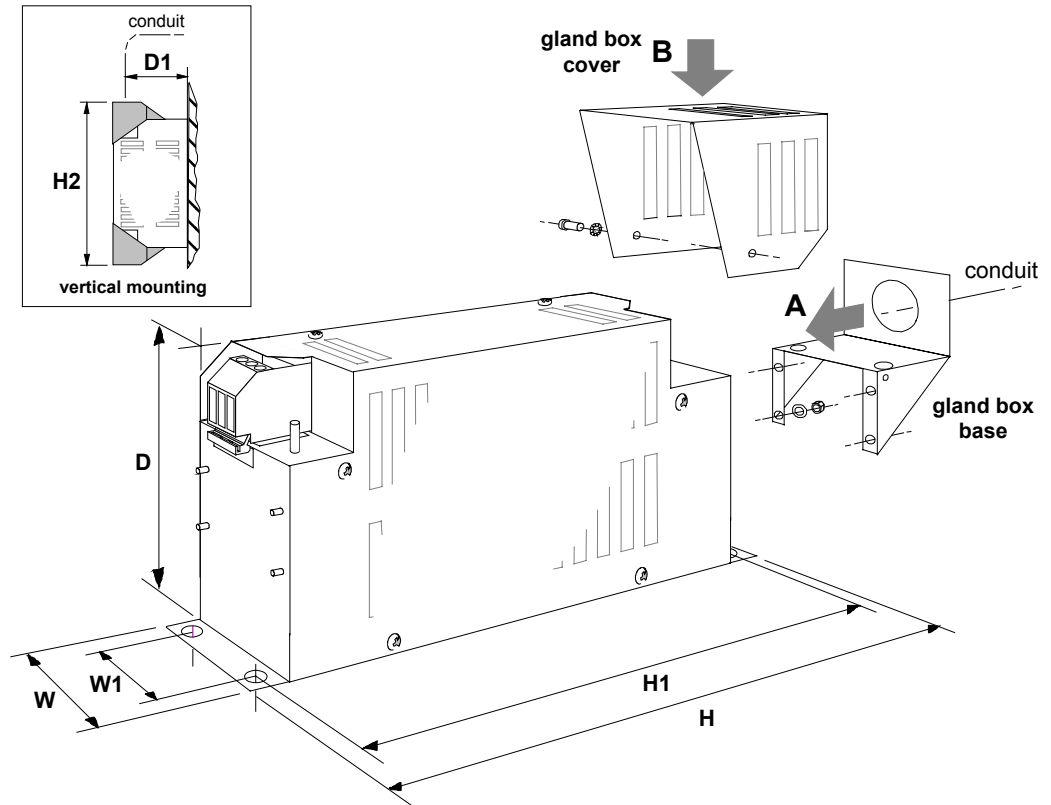

Figure 3-12 External AC Supply EMC Filter Outline Dimensions (CO465188U036 illustrated)

Model	H	H1	H2	W	W1	D	D1
CO465188U020	229	217	256	55	42	114	76
CO465188U036	272	258	295	74	60	161	123

Model	Phase	Frequency	Current	Voltage	Watt Loss
CO465188U020	3	50/60Hz	20A	520VAC	13W
CO465188U036	3	50/60Hz	36A	520VAC	16W

Table 3-3 External AC Supply EMC Filter Details (dimensions are in millimetres)

### WARNING!

Do not use an external ac supply EMC filter with supplies that are not balanced with respect to earth (IT). They must only be used with earth referenced supplies (TN).

Do not touch filter terminals or cabling for at least 3 minutes after removing the ac supply.

Only use the ac supply filter with a permanent earth connection.

Mount the filter as close as possible to the inverter.

If the filter is wall-mounted, it must be mounted vertically and fitted with the gland box base (A) and gland box cover (B). These items are not required if the filter is mounted inside a suitable cubicle.

Fit a gland box base (A) to the filter at both ends and secure the filter on the wall. Bring the conduit into each end and complete the wiring. Finally, secure the gland box covers (B) using the screws and washers.

The completed filter assembly provides IP4x rating from above and below, the remaining surfaces are IP2x.

- CO465188U020                      External AC Supply EMC Filter:  
back mounting - 4 x M6  
earth terminals - M5 stud  
mass - 1.2kg
- BA465189U020                      Gland Box Kit (both ends supplied):  
conduit hole diameter - 28.6mm (gland box base)
  
- CO465188U036                      External AC Supply EMC Filter:  
back mounting - 4 x M7  
earth terminals - M6 stud  
mass - 2.7kg
- BA465189U036                      Gland Box Kit (both ends supplied):  
conduit hole diameter - 28.6mm (gland box base)

Follow the cabling requirements given in Chapter 11: “Technical Specifications”

## EMC Motor Output Filter

This can help the Inverter achieve EMC and filter thermal conformance with cable lengths greater than those specified. It also ensures longer motor life by reducing the high voltage slew rate and overvoltage stresses. Mount the filter as close to the VSD as possible. Please refer to SSD Drives for the selection of a suitable filter.

## Output Contactors

Output contactors can be used, although we recommend that this type of operation is limited to emergency use only, or in a system where the inverter can be inhibited before closing or opening this contactor.

## Earth Fault Monitoring Systems

We do not recommend the use of circuit breakers (e.g. RCD, ELCB, GFCI), but where their use is mandatory, they should:

- Operate correctly with dc and ac protective earth currents (i.e. type B RCDs as in Amendment 2 of IEC755).
- Have adjustable trip amplitude and time characteristics to prevent nuisance tripping on switch-on.

When the ac supply is switched on, a pulse of current flows to earth to charge the internal/external ac supply EMC filter’s internal capacitors which are connected between phase and earth. This has been minimised in SSD Drives’ filters, but may still trip out any circuit breaker in the earth system. In addition, high frequency and dc components of earth leakage currents will flow under normal operating conditions. Under certain fault conditions larger dc protective earth currents may flow. The protective function of some circuit breakers cannot be guaranteed under such operating conditions.

### **WARNING!**

Circuit breakers used with VSDs and other similar equipment are not suitable for personnel protection. Use another means to provide personal safety. Refer to EN50178 (1997) / VDE0160 (1994) / EN60204-1 (1994)

## 3-14 Installing the Inverter

### **Line Chokes (input)**

Line chokes may be used to reduce the harmonic content of the supply current where this a particular requirement of the application or where greater protection from mains borne transients is required. Please refer to SSD Drives for the selection of a suitable line choke.

### **AC Motor Choke (output)**

Maximum Motor  $dv/dt = 10,000V/\mu s$ . This can be reduced by adding a motor choke in series with the motor.

Installations with longer than specified motor cable runs may suffer from nuisance overcurrent trips, refer to Chapter 11: “Technical Specifications” - Cabling Requirements for maximum cable lengths. A choke may be fitted in the inverter output to limit capacitive current. Screened cable has a higher capacitance and may cause problems in shorter runs.

**Note:** *Motor chokes must be fitted for 380-460V and 500V units with screened cable runs in excess of 50m; limit the switching frequency to 3kHz in these applications. Refer to Chapter 6: “Programming Your Application” - PATTERN GEN.*

Contact SSD Drives for further information.

# OPERATING THE INVERTER

## DEFAULT

*By default, the Inverter will operate in Remote Start/Stop and Remote Speed Control. Analog and digital inputs and outputs are selected to control the unit.*

*The Inverter will operate as an open-loop Inverter. No set-up or tuning is required. It is programmed to control an induction motor of equivalent power, current and voltage rating to the Inverter.*

*In this chapter, refer to “Control Philosophy”, “Start-up Routines”, “Remote Control using Control Terminals (default set-up)” and “The Start/Stop Mode Explained”.*

## Pre-Operation Checks

### WARNING!

Wait for 5 minutes after disconnecting power before working on any part of the system or removing the terminal cover from the Inverter.

#### Initial checks before applying power:

- Mains power supply voltage is correct.
- Motor is of correct voltage rating and is connected in either star or delta, as appropriate.
- Check all external wiring circuits - power, control, motor and earth connections.

**Note:** *Completely disconnect the Inverter before point to point checking with a buzzer, or when checking insulation with a Meggar.*

- Check for damage to equipment.
- Check for loose ends, clippings, drilling swarf etc. lodged in the Inverter and system.
- If possible check that the motor can be turned freely, and that any cooling fans are intact and free from obstruction.

#### Ensure the safety of the complete system before the Inverter is energised:

- Ensure that rotation of the motor in either direction will not cause damage.
- Ensure that nobody else is working on another part of the system which will be affected by powering up.
- Ensure that other equipment will not be adversely affected by powering up.

#### Prepare to energise the Inverter and system as follows:

- Remove the supply fuses, or isolate using the supply circuit breaker.
- Disconnect the load from the motor shaft, if possible.
- If any of the Inverter’s control terminals are not being used, check whether these unused terminals need to be tied high or low. Refer to Chapter 11: “Technical Specifications”- Control Terminals.
- Check external run contacts are open.
- Check external speed setpoints are all zero.

#### Re-apply power to the Inverter and system

The Inverter has Macro 1 installed as the factory default. If you are controlling the Inverter in Remote control, refer to Chapter 15: “Application Macros” for details of the most suitable macro for your application.

## 4-2 Operating the Inverter

### Control Philosophy

There are four ways to control the Inverter using Remote and Local control:

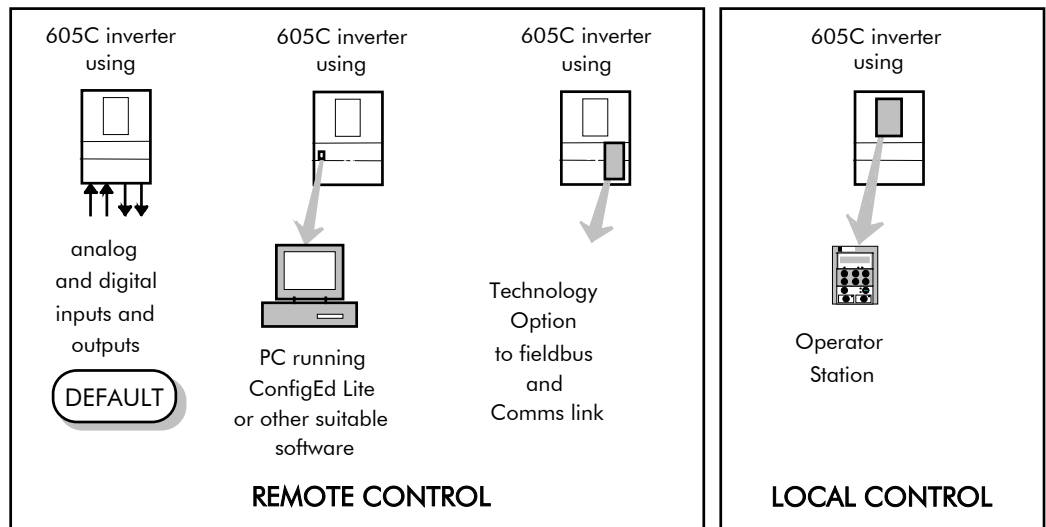

Figure 4-1 Remote and Local Control Modes

### Start/Stop and Speed Control

There are two forms of control in operation at any time: *Start/Stop* and *Speed Control*. Each can be individually selected to be under either Local or Remote Control.

- **Local or Remote Start/Stop** decides how you will start and stop the Inverter.
- **Local or Remote Speed Control** determines how you will control the motor speed.

In each case, Local and Remote control are offered by using the following:

**Local:** The Operator Station

**Remote:** Analog and digital inputs and outputs, RS232 Port or the Technology Option

Thus the Inverter can operate in one of four combinations of local and remote modes:

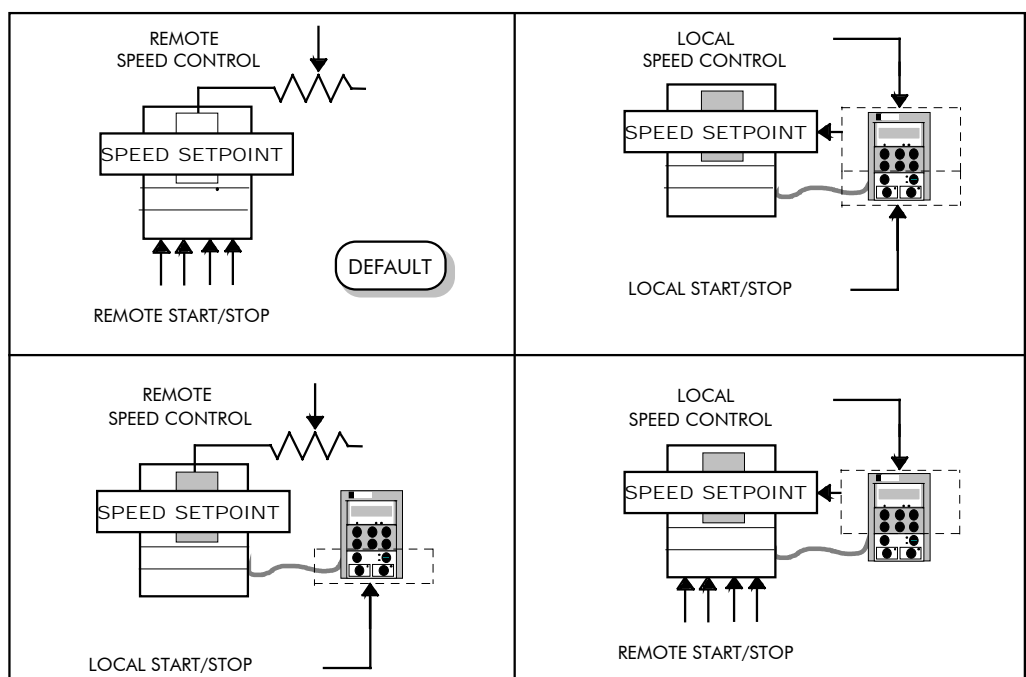

Figure 4-2 The Four Combinations of Local and Remote Control

**Note:** Start/Stop is also known as "Sequencing".  
Speed Control is also known as "Reference Generation".

## Selecting Local or Remote Control

If the default combination of remote Start/Stop and Speed Control is not suitable for your application, follow the instructions below using the Operator Station or a suitable PC programming tool to select suitable combinations of local or remote control.

**Note:** You can only change between Local and Remote control when the Inverter is "stopped".

To change a combination the Operator Station must have the "Advanced" viewing level selected; allowing you to view enough of the menu structure to make the change. Refer to Chapter 5: "The Operator Station" - Menu Viewing Levels.

The L/R key on the Operator Station toggles between **Local** and **Remote** control, changing both Start/Stop and Speed Control modes at the same time.

However, you can "fix" either or both modes in software to be either Local or Remote control. This makes the L/R key inoperative for that mode. In this way, you can select a combination where both Local and Remote modes are present.

To do this, go to the LOCAL CONTROL menu at level 4 and select either:

LOCAL ONLY	Sets Local control
REMOTE ONLY	Sets Remote control
LOCAL/REMOTE	Gives selection powers back to the L/R key.

Fixing only one of the modes will mean that the L/R key will still toggle the other mode between Local and Remote control.

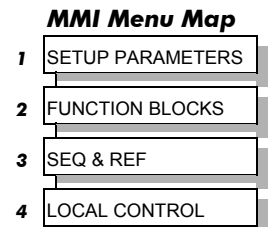

## LED Indications

The mode of control is indicated by the "LOCAL" LEDs on the Operator Station:

SEQ = Start/Stop  
REF = Speed Control

If the LED is illuminated (●), then LOCAL mode is in force.

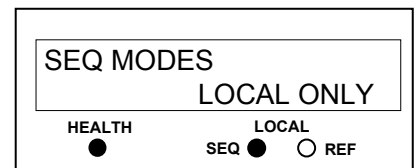

**Figure 4-3 Control Mode LED Indications**

**Note:** The default is for the L/R key to be operative for both Sequencing and Reference Generation, and to be set for Remote control, i.e. both LEDs will be off.

# 4-4 Operating the Inverter

## Start-up Routines

**IMPORTANT:** Refer to the ANALOG INPUT and ANALOG OUTPUT function blocks in Chapter 6 for the correct settings of Configuration Switches SW1 and SW2 before operation.

### Remote Control using Control Terminals (default set-up)

DEFAULT

This is the simplest method of operating the Inverter. No Set-up or tuning is required.

This routine assumes that the Inverter’s control terminals are wired as shown in Figure 3-9.

**Note:** Ensure that the speed potentiometer is set to zero.

1. Power-up the unit. The HEALTH LED will light (the RUN LED remains off).  
If the HEALTH LED flashes, the Inverter has tripped. Refer to Chapter 7: “Trips and Fault Finding” to investigate and remove the cause of the trip. Reset the unit by momentarily closing either the RESET switch or the RUN switch. The HEALTH LED will now light.
2. Close the RUN switch. The RUN LED will flash if the setpoint is at zero. Turn the speed potentiometer up a little to apply a small speed setpoint. The RUN LED will light and the motor will rotate slowly.

Reverse the motor’s direction of rotation either by pressing the DIR key, or by swapping two of the motor phases (**WARNING: Disconnect the mains supply first**).

### Reading the Status LEDs

The HEALTH and RUN LEDs indicate status. The LEDs are considered to operate in five different ways:

- OFF
- SHORT FLASH
- EQUAL FLASH
- LONG FLASH
- ON

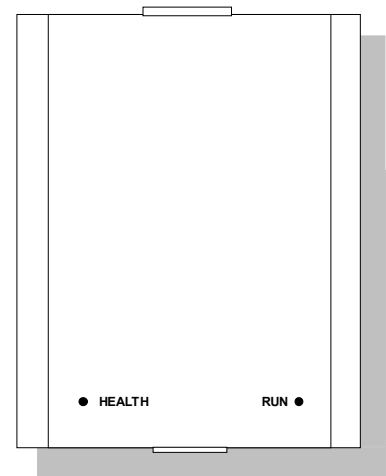

Figure 4-4 Blank Cover showing LEDs

HEALTH	RUN	Inverter State
<input type="checkbox"/> <input checked="" type="checkbox"/>	<input type="checkbox"/> <input checked="" type="checkbox"/>	Re-configuration, or corrupted non-volatile memory at power-up
<input type="checkbox"/> <input checked="" type="checkbox"/>	<input type="checkbox"/>	Tripped
<input type="checkbox"/> <input checked="" type="checkbox"/>	<input type="checkbox"/> <input checked="" type="checkbox"/>	Auto Restarting
<input checked="" type="checkbox"/>	<input type="checkbox"/>	Stopped
<input checked="" type="checkbox"/>	<input checked="" type="checkbox"/> <input type="checkbox"/>	Running with zero reference
<input checked="" type="checkbox"/>	<input checked="" type="checkbox"/>	Running
<input checked="" type="checkbox"/>	<input type="checkbox"/> <input checked="" type="checkbox"/>	Stopping
<input checked="" type="checkbox"/> <input type="checkbox"/>	<input checked="" type="checkbox"/> <input type="checkbox"/>	Braking and running with zero reference
<input checked="" type="checkbox"/> <input type="checkbox"/>	<input checked="" type="checkbox"/>	Braking and running
<input checked="" type="checkbox"/> <input type="checkbox"/>	<input type="checkbox"/> <input checked="" type="checkbox"/>	Braking and stopping

Table 4-1 Status indications given by the Health and Run LEDs

## Local Control using the Operator Station

**Note:** Refer to Chapter 5: “The Operator Station” to familiarise yourself with the Operator Station’s LED indications, and how to use the keys and menu structure.

The following start-up routine assumes that the Operator Station is fitted and is in default mode, and that the Inverter’s control terminals are wired as shown in Figure 3-9 Typical Connections to the Control Terminals.

1. Power-up the unit. The display will show the power-up screen, “AC MOTOR DRIVE”. After a few seconds, SETPOINT (REMOTE) % will appear on the display. The HEALTH, STOP, and FWD LEDs will light.

*If the HEALTH LED flashes, the Inverter has tripped. The display will indicate the reason for the trip. Refer to Chapter 7: “Trips and Fault Finding” to investigate and remove the cause of the trip. Reset the trip condition by pressing the Stop/Reset key on the keypad. The HEALTH LED will now light.*

2. Press the L/R (Local/Remote) key to enable Local control. Both the LOCAL SEQ and LOCAL REF LEDs will light when Local control is enabled.
3. Press the RUN key. The RUN LED will light and the motor will rotate slowly. (The RUN LED would flash if the setpoint was at zero.)
4. Reverse the motor’s direction of rotation by pressing either the DIR key, or by swapping two of the motor phases (**WARNING: Disconnect the mains supply first**).

## Setting-up the Inverter

The Inverter is set-up using the Autotune feature, the Operator Station, or a suitable PC programming tool. It can be run in Sensorless Vector Fluxing mode, or as a simple Open-loop Inverter (V/F fluxing).

### Quick Set-up as an Open-loop Inverter (V/F fluxing)

By loading a different macro, you are installing the default settings for that macro’s application. Once a macro has been loaded (or the default is used), the parameters most likely to require attention are contained in the QUICK SETUP menu at level 2.

#### MMI Menu Map

1	SETUP PARAMETERS
2	QUICK SETUP

Parameters	Default	Brief Description
BASE FREQUENCY	* 50.0 Hz	Frequency at which Inverter gives maximum output volts
MAX SPEED	* 50.0 Hz	Max speed clamp and scale factor for other speed parameters
MIN SPEED	-100.00 %	Min speed clamp
RAMP ACCEL RATE	10.0 s	Acceleration time from 0Hz to max speed
RAMP DECEL RATE	10.0 s	Deceleration time from max speed to 0Hz
V/F SHAPE	LINEAR LAW	Constant torque V to F characteristic
QUADRATIC TORQUE	FALSE	Selects higher continuous rating with less overload capability (Chapter 6: Quadratic Torque Selection)
FULL LOAD CALIB	** 3.4 A	Calibrates Inverter to motor full load current
NO LOAD CALIB	** 1.9 A	Calibrates Inverter to motor no load current
POWER FACTOR	** 0.80	Set this to the motor power factor rating
MOTOR CURRENT	xxx.x A	Motor current diagnostic (read only)
MOTOR I LIMIT	100.00%	Level of motor current as % of FULL LOAD CALIB
FIXED BOOST	6.00 %	Boosts starting torque by adding volts at low speed
RUN STOP MODE	RAMPED	Ramp to standstill when RUN signal removed
JOG SETPOINT	10.0 %	Inverter speed setpoint whilst jogging
AIN 1 TYPE	0..+10V	Input range and type
AIN 2 TYPE	0..+10V	Input range and type
DISABLED TRIPS	0600 >>	Sub-menu to set disabled trips
DISABLED TRIPS+	0000 >>	Sub-menu to set additional disabled trips
* These values are dependent upon the Language field of the Product Code, e.g. UK		
** These values are dependent upon the “power build” of the unit, indicated by the Product Code		

Table 4-2 Important Parameters for the Open-loop Inverter

## 4-6 Operating the Inverter

### Set-up using the Sensorless Vector Fluxing Mode

The Inverter must be tuned to the motor in use by matching the motor parameters in the Inverter to those of the motor being controlled. The most important motor parameters are:

- Per-phase stator resistance
- Per-phase leakage inductance
- Per-phase mutual (magnetising) inductance

#### MMI Menu Map

1	SETUP PARAMETERS
2	VECTOR SETUP

Tuning can be performed manually by entering known parameter values, or by calculating the parameter values using the motor manufacturer's per-phase equivalent circuit.

Enter values for the following parameters, found under VECTOR SETUP menu at level 2.

VECTOR SETUP Parameters	Default	Brief Description
VECTOR ENABLE	FALSE	Slip compensation is enabled. Change to TRUE to enable sensorless vector operation
NAMEPLATE RPM	** 1420 n/min (rpm)	Motor nameplate speed
MOTOR POLES	4	Number of motor poles
MOTOR VOLTS	** 400.0 V	Maximum motor output voltage
SUPPLY VOLTAGE	** xxx.x V	Line-to-line rms supply voltage to the Inverter (read-only)
MOTOR CONNECTION	** DELTA	Type of motor connection
AUTOTUNE ENABLE	FALSE	Enables the Autotune feature
STATOR RES	** 1.0 Ohm	Motor per-phase stator resistance
FIELD	0.0%	Diagnostic only
LEAKAGE INDUC	** 10.0 mH	Motor per-phase stator leakage inductance
MUTUAL INDUC	** 1000.0mH	Motor per-phase stator mutual (magnetising) inductance
** These values are dependent upon the "power build" of the unit, indicated by the Product Code		

Table 4-3 Important Parameters for the Sensorless Vector Fluxing Mode

### The Autotune Feature

The Autotune feature can be used to identify and store the following parameters:

- STATOR RES
- LEAKAGE INDUC
- MUTUAL INDUC
- CURRENT FEEDBACK (if selected in the AUTOTUNE function block)

The remaining important parameters are preset to a value depending on the overall "power-build", as detailed in the table above.

Operating the Inverter with the Autotune function block enabled starts the Autotune sequence.

- With ADVANCED view level selected, select the AUTOTUNE menu at level 4. Press the **M** key to reveal the AUTOTUNE ENABLE page.
- Press the **M** key. The up ( $\Delta$ ) and down ( $\nabla$ ) keys toggle the parameter between TRUE and FALSE. Set to TRUE. Press the **E** key to exit the parameter.
- On starting the Inverter, the Autotune sequence is initiated. When complete (after a maximum of 10 seconds), the Inverter is returned to the stopped condition and the AUTOTUNE ENABLE parameter is reset to FALSE.

#### MMI Menu Map

1	SETUP PARAMETERS
2	FUNCTION BLOCKS
3	MOTOR CONTROL
4	AUTOTUNE
	AUTOTUNE ENABLE
	AUTOTUNE MODE
	AUTOTUNE ACTIVE

Refer to Chapter 6: "Programming Your Application" - AUTOTUNE for further information.

## Manual Tuning

### Tuning using the Motor Equivalent Circuit

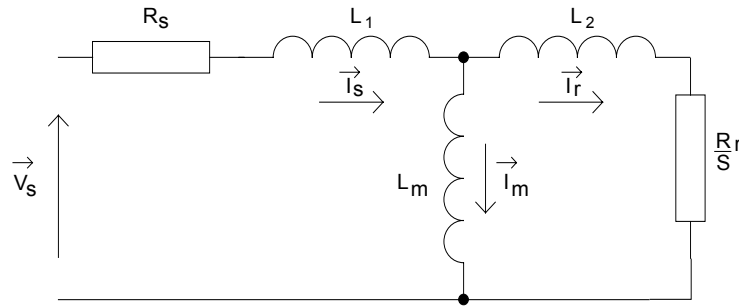

Figure 4-5 The Motor Equivalent Circuit

From the motor equivalent circuit, the values programmed into the Inverter are:

$$\text{STATOR RES} = R_s \quad \text{Ohms}$$

$$\text{LEAKAGE INDUC} = (L_1 + L_m) - \frac{(L_m)^2}{(L_2 + L_m)} \quad \text{mH}$$

$$\text{MUTUAL INDUC} = \frac{(L_m)^2}{(L_2 + L_m)} \quad \text{mH}$$

### Tuning using a Simple Tuning Sequence

If the motor equivalent circuit is not available, the following simple tuning sequence can be used. All QUICK SETUP parameters must be correctly set, including FULL LOAD CALIB and NO LOAD CALIB:

- Set FULL LOAD CALIB to the rms current given on the motor nameplate
- Set NO LOAD CALIB to the Inverter's rms line current value while running the motor at base frequency (V/F) under no-load conditions.

Now set the following parameters in this order to complete the manual tuning process.

NAMEPLATE RPM	Enter the motor nameplate rated speed	<b>MMI Menu Map</b> 1 SETUP PARAMETERS 2 VECTOR SETUP							
MOTOR POLES	Enter the number of motor poles								
SUPPLY VOLTAGE	Enter the Inverter rms line-to-line volts	<b>MMI Menu Map</b> 1 SETUP PARAMETERS 2 VECTOR SETUP							
MOTOR CONNECTION	Enter the motor 3-phase connection type								
VECTOR ENABLE	Set to TRUE.								
STATOR RES	Set STATOR RES to zero. Run motor at zero speed (unloaded). Note the BOOST parameter value (see PATTERN GEN). Calculate STATOR RES as follows and enter the result:								
	<table border="1" style="display: inline-table; margin-right: 20px;"> <tr> <td style="text-align: center;"><i>STAR CONNECTION</i></td> <td style="text-align: center;">BOOST</td> </tr> <tr> <td style="text-align: center;">STATOR RES =</td> <td style="text-align: center;"><math>\frac{\text{BOOST}}{\sqrt{3} \times \text{NO LOAD CALIB}}</math></td> </tr> </table> <table border="1" style="display: inline-table;"> <tr> <td style="text-align: center;"><i>DELTA CONNECTION</i></td> <td style="text-align: center;"><math>\sqrt{3} \times \text{BOOST}</math></td> </tr> <tr> <td style="text-align: center;">STATOR RES =</td> <td style="text-align: center;"><math>\frac{\sqrt{3} \times \text{BOOST}}{\text{NO LOAD CALIB}}</math></td> </tr> </table>		<i>STAR CONNECTION</i>	BOOST	STATOR RES =	$\frac{\text{BOOST}}{\sqrt{3} \times \text{NO LOAD CALIB}}$	<i>DELTA CONNECTION</i>	$\sqrt{3} \times \text{BOOST}$	STATOR RES =
<i>STAR CONNECTION</i>	BOOST								
STATOR RES =	$\frac{\text{BOOST}}{\sqrt{3} \times \text{NO LOAD CALIB}}$								
<i>DELTA CONNECTION</i>	$\sqrt{3} \times \text{BOOST}$								
STATOR RES =	$\frac{\sqrt{3} \times \text{BOOST}}{\text{NO LOAD CALIB}}$								
LEAKAGE INDUC	Set to zero and run motor at base-frequency un-loaded								
MUTUAL INDUC	Alter until FIELD diagnostic reads approximately 100%.								

$$\text{STAR CONNECTION} \quad \text{STATOR RES} = \frac{\text{BOOST}}{\sqrt{3} \times \text{NO LOAD CALIB}}$$

$$\text{DELTA CONNECTION} \quad \text{STATOR RES} = \frac{\sqrt{3} \times \text{BOOST}}{\text{NO LOAD CALIB}}$$

- LEAKAGE INDUC Set to zero and run motor at base-frequency un-loaded
- MUTUAL INDUC Alter until FIELD diagnostic reads approximately 100%.
1. Take the manually tuned value for MUTUAL INDUC, and split it into 20% and 80% portions.
  2. Enter the 20% portion into LEAKAGE INDUC parameter
  3. Enter the 80% portion into MUTUAL INDUC parameter.

**IMPORTANT:** Remember to save the parameter settings.

## 4-8 Operating the Inverter

### Tuning Difficulties

The most important parameter setting for correct operation at low motor speeds is stator resistance (STATOR RES):

- *Too low* and motor torque will be lower than expected
- *Too high* and the Inverter enters the current limit and will be unable to ramp-up to speed. Reduce the value of STATOR RES to eliminate this problem.

See VECTOR FLUXING at menu level 4.

#### MMI Menu Map

1	SETUP PARAMETERS
2	FUNCTION BLOCKS
3	MOTOR CONTROL
4	VECTOR FLUXING

## The Start/Stop Mode Explained

The default configuration below shows the Inverter in Remote control, (using the analog and digital inputs and outputs). This example will be referred to in the following explanations.

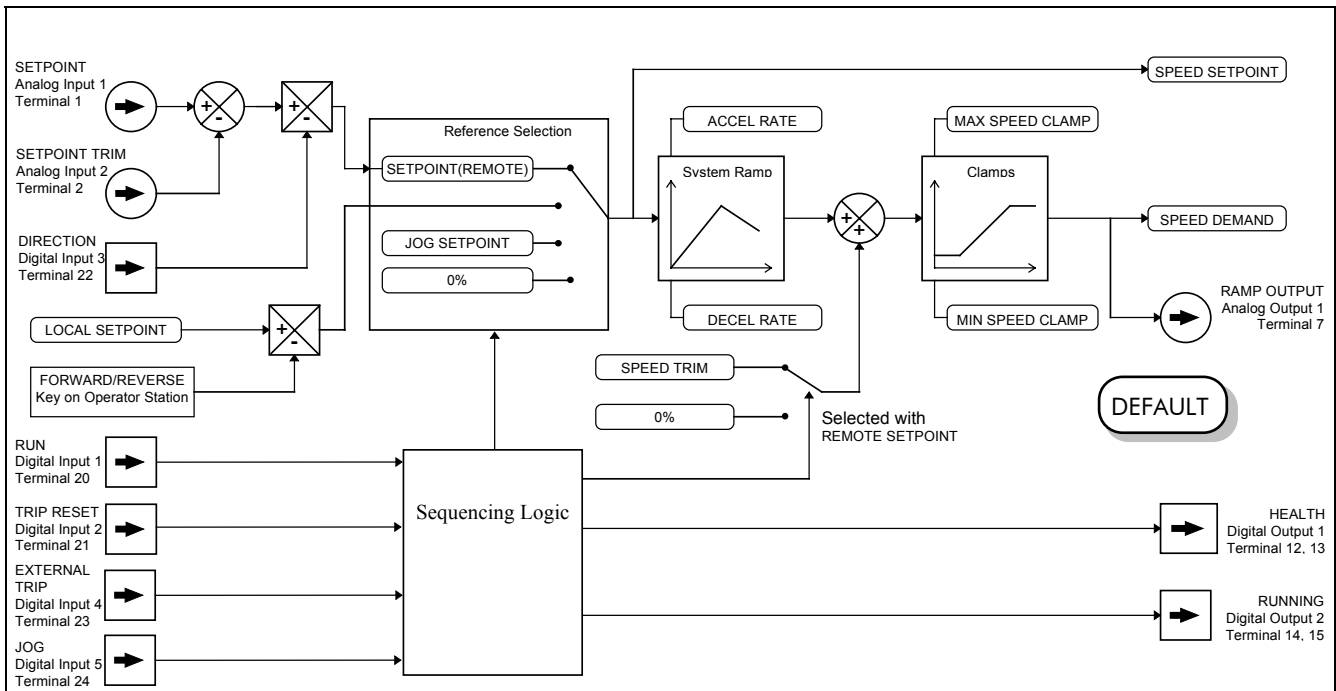

Figure 4-6 Portion of the Default Configuration

### Start/Stop Controlled Remotely

DEFAULT

In the configuration shown, the reference value is obtained by summing ANALOG INPUT 1 and ANALOG INPUT 2. The direction of rotation is controlled by DIGITAL INPUT 3. When the RUN input (DIGITAL INPUT 1) is TRUE, the SPEED DEMAND ramps up to the reference value at a rate controlled by ACCEL RATE. The Inverter will continue to run at the reference value while the RUN input remains TRUE.

Similarly when the JOG input (DIGITAL INPUT 5) is TRUE, the SPEED DEMAND ramps up to the JOG SETPOINT at a ramp rate set by JOG ACCEL RATE (not shown in the diagram). The Inverter will continue to run at the JOG SETPOINT while the JOG input remains TRUE.

### Start/Stop Controlled Locally

The reference value is set by the SETPOINT (LOCAL) parameter. The direction of rotation is controlled by the DIR key (forward/reverse) on the Operator Station. When the RUN key is pressed the SPEED DEMAND ramps up to the reference value at a rate controlled by ACCEL RATE. The Inverter will continue to run at the reference value even when the RUN key is released. Press the STOP key to “stop” the Inverter.

When the JOG key is pressed and held, the SPEED DEMAND ramps up to the JOG SETPOINT at a ramp rate set by JOG ACCEL RATE (not shown in the diagram). Release the JOG key to “stop” the Inverter.

### Interaction between RUN and JOG

Only one of these signals can be in effect at any one time; the other signal is ignored. The Inverter must be “stopped” to change from running to jogging, or vice versa.

### Start/Stop Mode Diagnostics

In the configuration shown, Start/Stop mode provides two DIGITAL OUTPUT signals (RUN and HEALTH).

The RUN signal is TRUE from the time a start command is processed until a stop sequence is completed. This normally means the time between the Inverter starting until the power stack is quenched. Refer to Chapter 9: “Sequencing Logic States” for a more detailed description.

The HEALTH output is TRUE when the Inverter is not tripped.

Additional diagnostic parameters are available when using the Operator Station. These are described in Chapter 6: “Programming Your Application” and Chapter 9: “Sequencing Logic States”.

## Starting and Stopping Methods

**Note:** Refer to Chapter 6: “Programming Your Application - REFERENCE, SEQUENCING LOGIC, STOP and SYSTEM RAMP, for explanations of parameters.

### Normal Stopping Methods

DEFAULT

Macro 1 is set to “RAMPED” (see RUN STOP MODE function block) at STOP RATE set to 10.0s (see STOP function block).

With the Operator Station, or suitable programming tool, the Inverter can be selected to “Coast to Stop”, or to “Ramp to Stop” at one of two rates (STOP RATE or FAST STOP RATE). The stopping procedure is different for Local and Remote Start/Stop. Refer to “Start/Stop Controlled Locally”, page 4-8 and “Start/Stop Controlled Remotely”, page 4-8.

### Ramp to Stop

When a stop command is received, the Inverter decelerates from its actual speed towards zero for the programmed RAMP DECEL RATE time. When this time has elapsed, SPEED TRIM is ramped to 0% in the programmed STOP RATE time.

**Note:** If SPEED TRIM does not operate, SPEED DEMAND is reduced to 0% in RAMP DECEL RATE time.

The power stack remains energised until the STOP DELAY period has elapsed.

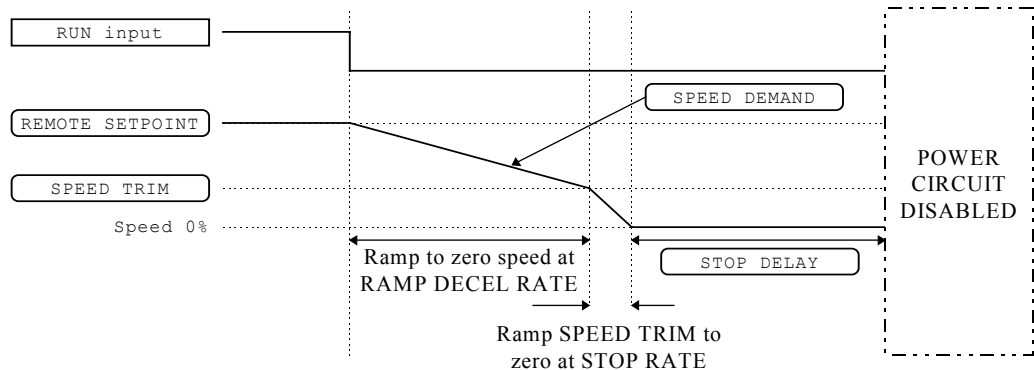

Figure 4-7 Ramp to Stop with a Remote Reference

# 4-10 Operating the Inverter

A special case exists when the RAMP DECEL RATE is set to 0.0 seconds, or when the RAMP HOLD parameter is TRUE. In both these situations the SPEED DEMAND will ramp down to zero at the STOP RATE.

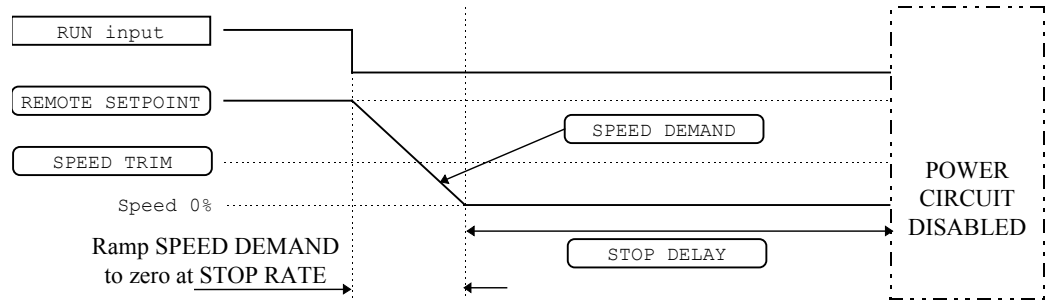

Figure 4-8 Remote to Stop with a Remote Reference: no RAMP DECEL RATE

## Coast to Stop

In this mode the RAMP DECEL RATE ramp and the STOP RATE ramp are both ignored. Thus the SPEED DEMAND changes immediately to 0% as soon as the Stop command is given. The power stack is also immediately disabled at this time, causing the load to coast.

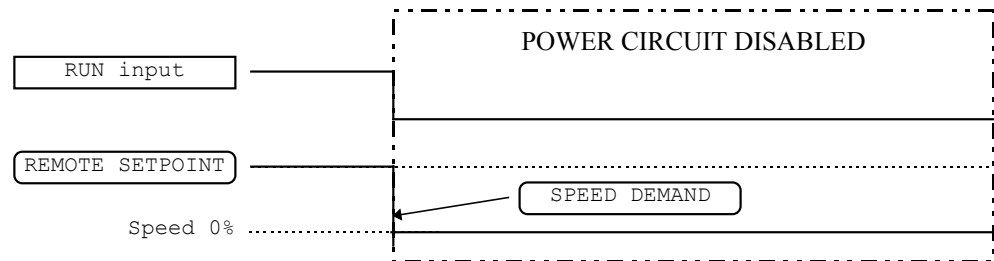

Figure 4-9 Coast to Stop with a Remote Reference

## Advanced Stopping Methods

The Inverter can be selected to /FAST STOP or to /COAST STOP. The stopping procedure is unaffected by Local or Remote Sequencing options.

### Forced Fast Stop

The /Fast Stop mode overrides the RUN FWD, RUN REV and JOG inputs in Remote mode, and the RUN and JOG Operator Station keys in Local mode. It is selected by setting /FAST STOP to TRUE.

The Fast Stop mode can be set to either RAMP or COAST. The stopping sequence starts when the /FAST STOP input goes FALSE, regardless of the state of the RUN input.

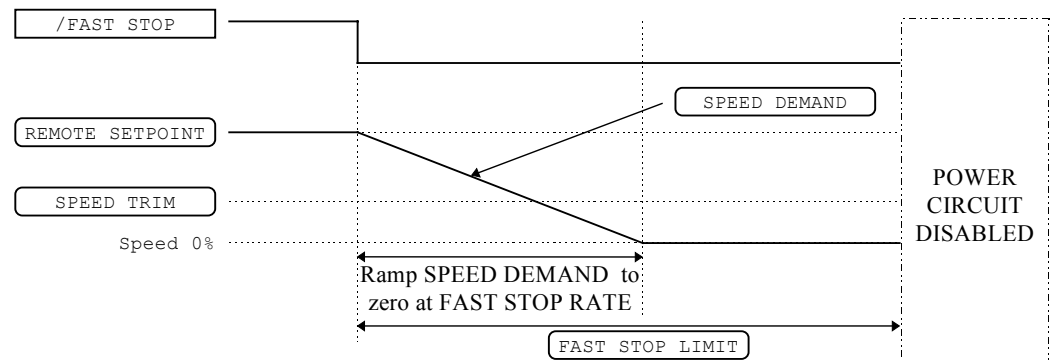

Figure 4-10 Forced Fast Stop RAMP Mode example

### Forced Coast Stop

Using the /Coast Stop mode immediately disables the power stack, causing the load to coast to a stop. The Inverter gives priority to the /COAST STOP signal. The /FAST STOP signal is therefore ignored while /COAST STOP is active.

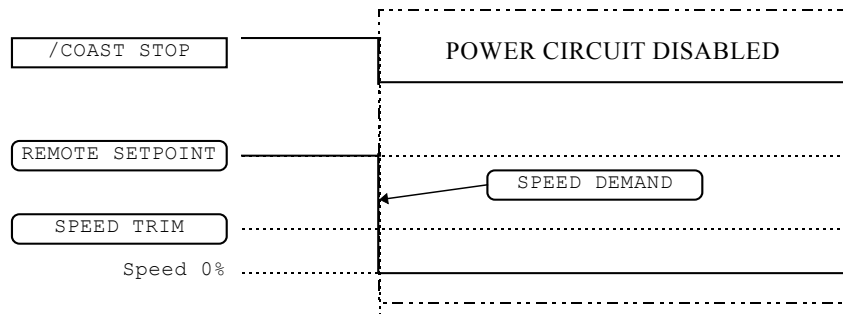

Figure 4-11 Forced Coast Stop example

### The Trip Condition

When a trip condition is detected, a similar stopping method to /COAST STOP is used. The power stack cannot be re-enabled until the trip condition has been cleared and successfully reset.

Refer to Chapter 7: “Trips and Fault Finding” for further details.

### Logic Stopping

The Inverter can be stopped by setting the /STOP to FALSE for a short time, (>100 ms). The stop sequence continues even if the /STOP signal goes inactive before the Inverter is stopped. Various combinations of stop logic are shown below.

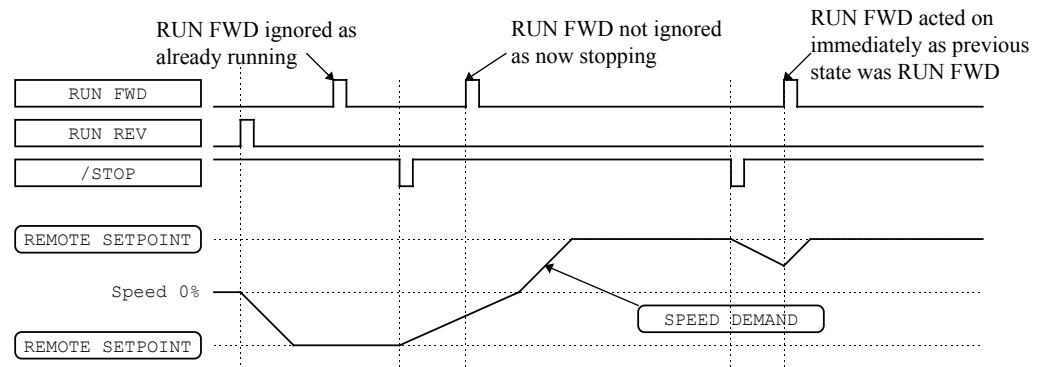

Figure 4-12 Interaction between RUN FWD, RUN REV and /STOP Parameters

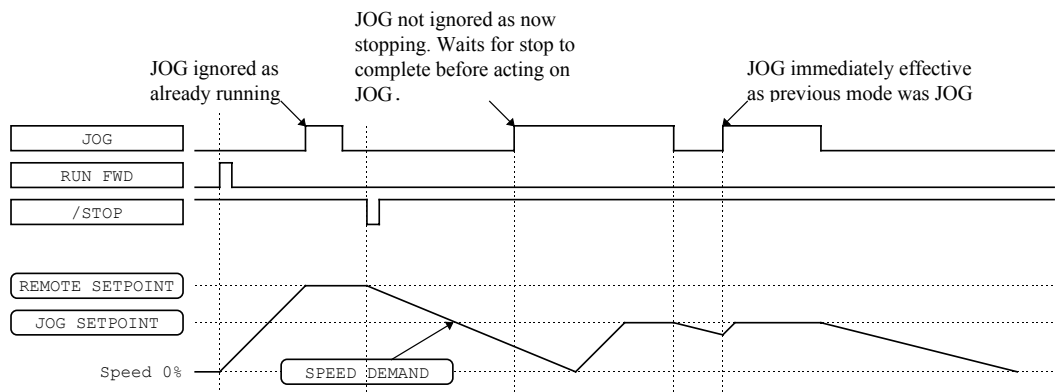

Figure 4-13 Example of the Interaction between RUN and JOG Parameters

# 4-12 Operating the Inverter

## Normal Starting Method

DEFAULT

In the default configuration view, two digital input signals are used to control the RUN FWD parameter and the REMOTE REV parameter, as shown below. Note that the /STOP parameter is active, (FALSE), meaning that the Inverter will only run while the relevant RUN parameters are held TRUE.

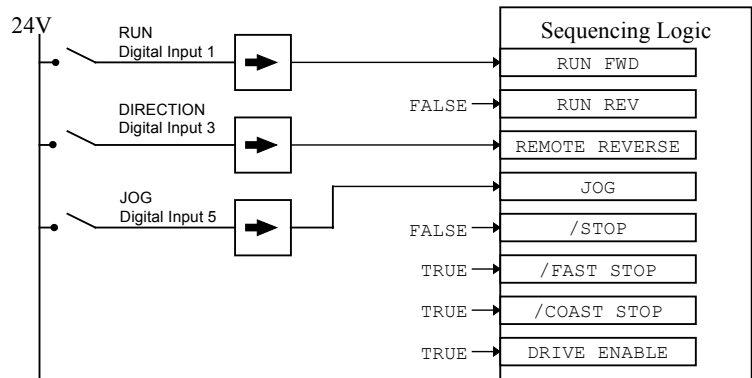

Figure 4-14 Default Sequencing Wiring

## Advanced Starting Methods

### Starting Several Inverters Simultaneously

**IMPORTANT:** We do not recommend that this signal is used to start an Inverter in “normal” use.

Use the DRIVE ENABLE parameter to control the output power stack. When this parameter is FALSE, the power stack is disabled regardless of the state of any other parameters. In conjunction with the HEALTHY output parameter, DRIVE ENABLE can synchronise several Inverters on power-up.

### Single Wire Logic Starting

Use this when the motor direction will always be the same. The motor will run while the switch is closed, and will stop when it is open.

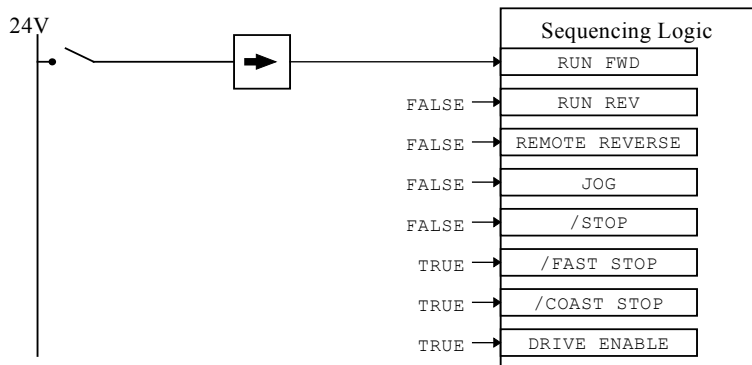

Figure 4-15 Single Wire Sequencing example

### Two Wire Logic Starting

This is an alternative to the default configuration. The Inverter can operate in forward and reverse depending upon which switch is closed. If both RUN FWD and RUN REV are TRUE at the same time, both are ignored and the Inverter will stop.

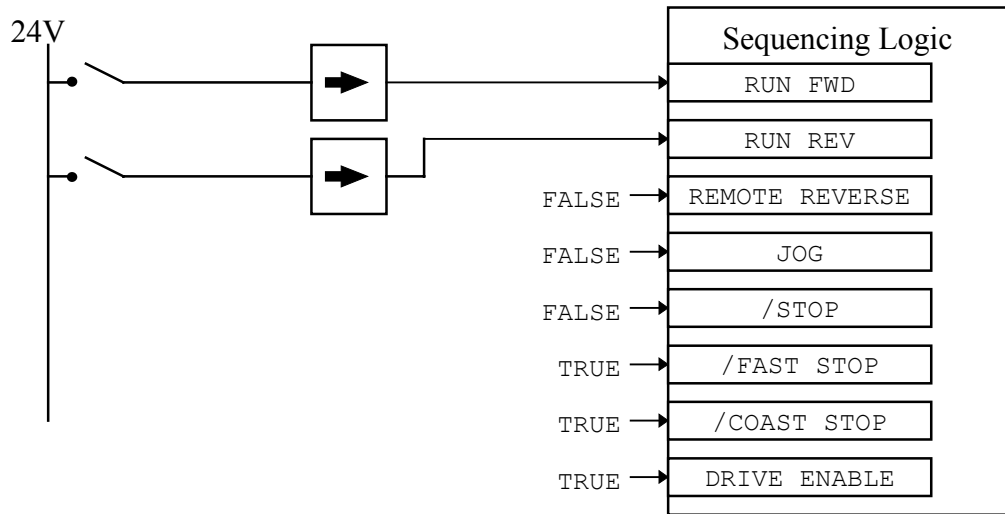

Figure 4-16 Two Wire Sequencing example

### Three Wire Logic Starting

In this example the /STOP parameter is inactive using a digital input. In this situation the RUN FWD and RUN REV signals are latched.

For example, setting RUN FWD to TRUE temporarily, (> 100ms), by closing the push button switch causes the Inverter to start running. The Inverter continues running when the push button contact is released causing RUN FWD to return to FALSE. While the Inverter is running forwards, the RUN REV parameter is ignored until the Inverter is stopped, even though the RUN FWD signal is now FALSE.

The JOG parameter is never latched in this way. The Inverter only jogs while the JOG parameter is TRUE.

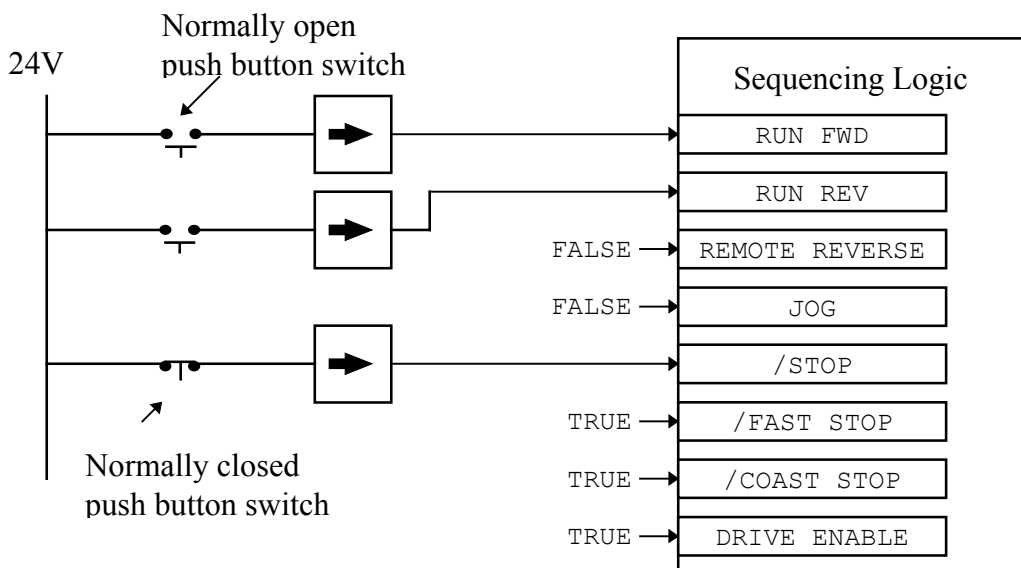

Figure 4-17 Push Button Bi-directional Sequencing example

## 4-14 Operating the Inverter

# THE OPERATOR STATION

## Connecting the Operator Station

The Operator Station is a plug-in MMI (Man-Machine Interface) option that allows full use of the Inverter's features.

It provides local control of the Inverter, monitoring, and complete access for application programming.

Insert the Operator Station into the front of the Inverter (replacing the blank cover and plugging into the RS232 programming port); or mount it up to 3 metres away using the optional panel mounting kit with connecting lead. Refer to Chapter 3: "Installing the Inverter - Fitting the Remote 6051 Operator Station.

Two Operator Stations (or one and a PC running a suitable programming software) can be used simultaneously, each reflecting the others settings.

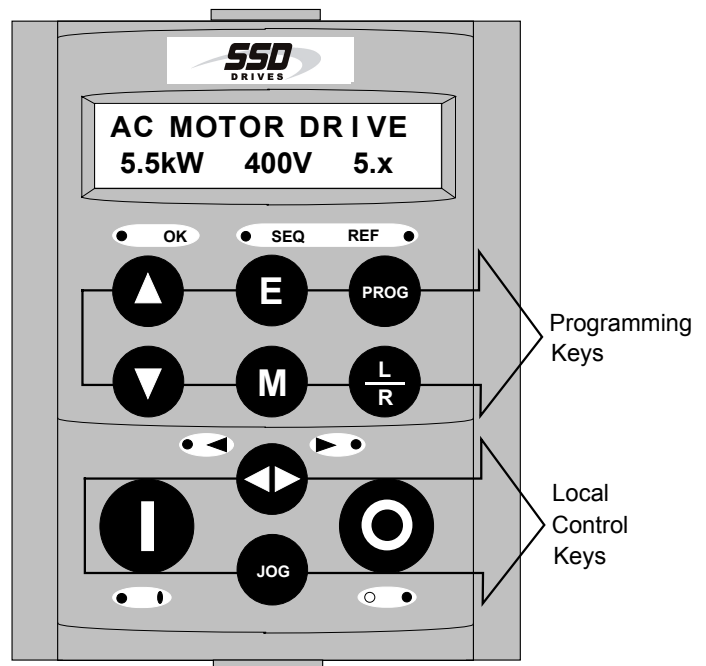

Figure 5-1 Operator Station displaying Welcome Screen

### Welcome Screen

On power-up, a default Welcome screen is displayed for several seconds showing the product description; power rating, voltage and software version of the Inverter.

After a few seconds the display changes to SETPOINT (REMOTE) by default.

## Customising the Operator Station

This chapter contains information on how to customise the Operator Station to your application. Below are some of the ways in which you can make the Operator Station work effectively for you.

Consider the following features:

- The Welcome screen can be customised so that it displays the process name, for example.
- Create two custom screens for the user, using units and names relevant to the process.
- Choose which parameters you need to see in the OPERATOR menu.
- Set a password for the Operator Station to make all parameters "read-only"
- Enable/disable the keys on the Operator Station as required, i.e., JOG, DIR etc.
- Select the correct viewing level to reduce the menu size for easy operation.

**HINT:** Customise the action of the Operator Station to create an effective working tool. Spend time setting up the OPERATOR menu, as this is the list of parameters most used in the operation of your Inverter. Refer to "Special Menu Features", page 5-8.







## Controlling the Drive using the Operator Station

### Control Key Definitions





**Note:** Refer to Chapter 4: "Operating the Inverter" for more detail about Remote and Local modes.

### Keys for Programming the Drive

**Note:** See "Navigating the Menu System", page 5-4 for a quick-start to using the menu.



<p>UP</p> 	<p>Navigation - Moves upwards through the list of parameters.</p> <p>Parameter - Increments the value of the displayed parameter.</p> <p>Command Acknowledge - Confirms action when in a command menu.</p>
<p>DOWN</p> 	<p>Navigation - Moves downwards through the list of parameters.</p> <p>Parameter - Decrements the value of the displayed parameter.</p>
<p>ESCAPE</p> 	<p>Navigation - Displays the previous level's Menu.</p> <p>Parameter - Returns to the parameter list.</p> <p>Trip Acknowledge - Acknowledges displayed Trip or Error message.</p>
<p>MENU</p> 	<p>Navigation - Displays the next Menu level, or the first parameter of the current Menu.</p> <p>Parameter - Allows a writable parameter to be modified (this is indicated by → appearing on the left of the bottom line).</p>
<p>PROG</p> 	<p>Navigation - Toggles between current locations within the Operator menu and any other menu.</p>
<p>LOCAL/ REMOTE</p> 	<p>Control - Toggles between Remote and Local Control for both Start/Stop (Seq) and Speed Control (Ref). When toggling, the display automatically goes to the relevant SETPOINT screen, and the SETPOINT (LOCAL) screen will have the ▲ and ▼ keys enabled to alter the setpoint.</p>

### Keys for Operating the Drive Locally





























<p>FORWARD/ REVERSE</p> 	<p>Control - Changes the direction of motor rotation. Only operates when the drive is in Local Speed Control mode.</p>
<p>JOG</p> 	<p>Control - Runs the motor at a speed determined by the JOG SETPOINT parameter. When the key is released, the drive returns to "stopped". Only operates when the drive is "stopped" and in Local Start/Stop mode.</p>
<p>RUN</p> 	<p>Control - Runs the motor at a speed determined by the LOCAL SETPOINT or REMOTE SETPOINT parameter.</p> <p>Trip Reset - Resets any trips and then runs the motor as above. Only operates when the drive is in Local Start/Stop (Seq) mode.</p>
<p>STOP/RESET</p> 	<p>Control - Stops the motor. Only operates when the drive is in Local Sequence mode.</p> <p>Trip Reset - Resets any trips and clears displayed message if trip is no longer active.</p>









## LED Indications





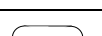

There are seven LEDs that indicate the status of the Inverter. Each LED is considered to operate in three different ways:

-  OFF
-  FLASH
-  ON

The LEDs are labelled HEALTH, LOCAL (as SEQ and REF), FWD, REV, RUN, and STOP. Combinations of these LEDs have the following meanings:

HEALTH	RUN	STOP	Inverter State
 	 	 	Re-Configuration
 			Tripped
			Stopped
		 	Stopping
	 		Running with zero reference
			Running
	 	 	Autotuning

FWD	REV	Forward / Reverse State
		Requested direction and actual direction are forward
		Requested direction and actual direction are reverse
 		Requested direction is forward but actual direction is reverse
	 	Requested direction is reverse but actual direction is forward

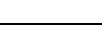
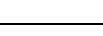
LOCAL SEQ	LOCAL REF	Local / Remote Mode
		Start/Stop (Seq) and Speed Control (Ref) are controlled from the terminals
		Start/Stop (Seq) is controlled using the RUN, STOP, JOG and FWD/REV keys. Speed Control (Ref) is controlled from the terminals
		Start/Stop (Seq) is controlled from the terminals Speed Control (Ref) is controlled using the up (Δ) and down (∇) keys
		Start/Stop (Seq) and Speed Control (Ref) are controlled using the Operator Station keys

## The Menu System

The menu system is divided into a 'tree' structure with 5 menu levels. Menu Level 1 is at the top of the tree. Parameters contained in Menu Level 1 are the most frequently used, as you descend the menu levels the parameters are less frequently used.

The Operator Station has selectable "viewing levels" which can restrict the view of the menu system, refer to "Menu Viewing Levels", page 5-11.

Below is a simple description of the menus at Menu Level 1:

- OPERATOR: a view of selected parameters contained in the FUNCTION BLOCKS menu. You can customise the Operator menu to create a working list of parameters for operating your Inverter.
- DIAGNOSTICS: a view of important diagnostic parameters contained in the FUNCTION BLOCKS menu.
- SETUP PARAMETERS: contains all the function block parameters for programming your application, including parameters for tuning the Inverter.
- PASSWORD: a view of important Password parameters contained in the FUNCTION BLOCKS menu.
- TRIPS STATUS: a view of the trip diagnostic parameters contained in the FUNCTION BLOCKS menu.
- MENUS: a view of parameters contained in the FUNCTION BLOCKS menu for setting-up the Operator Station display.
- PARAMETER SAVE: Save the application.
- SYSTEM: Macro selection and enter/exit Configuration Mode.

Figure 5-1 The Menu System showing Menus at Level 1

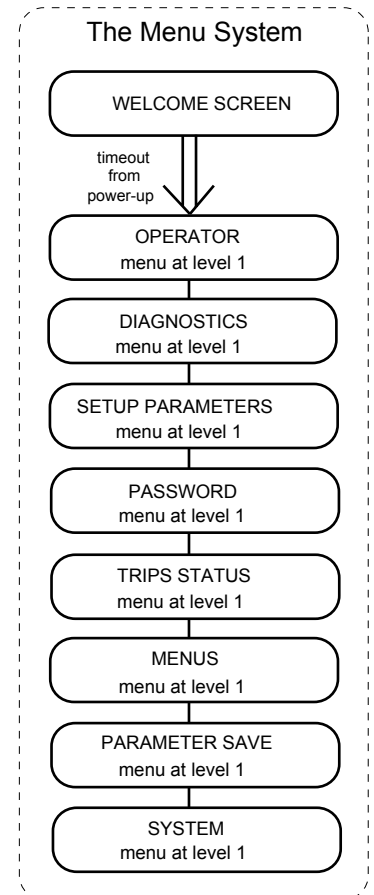

## Navigating the Menu System

On power-up, the Operator Station defaults into the OPERATOR menu, timing out from the Welcome screen. You can skip the timeout by pressing the **M** key immediately after power-up which will take you directly to the OPERATOR menu.

The menu system can be thought of as map which is navigated using the four keys shown opposite.

Keys **E** and **M** navigate through the menu levels. The up ( $\Delta$ ) and down ( $\nabla$ ) keys scroll through the Menu and Parameter lists.

Refer to "The Menu System Map" to see how the menu is mapped.

**HINT:** Remember that because the Menu and Parameter lists are looped, the  $\Delta$  key can quickly move you to the last Menu or Parameter in the loop.

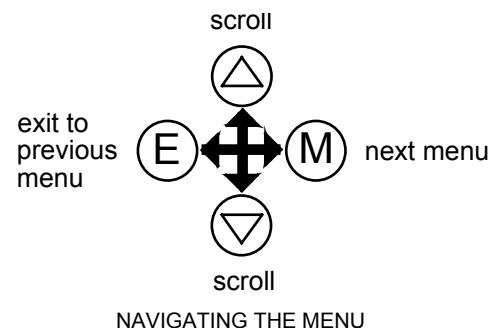

# The Menu System Map

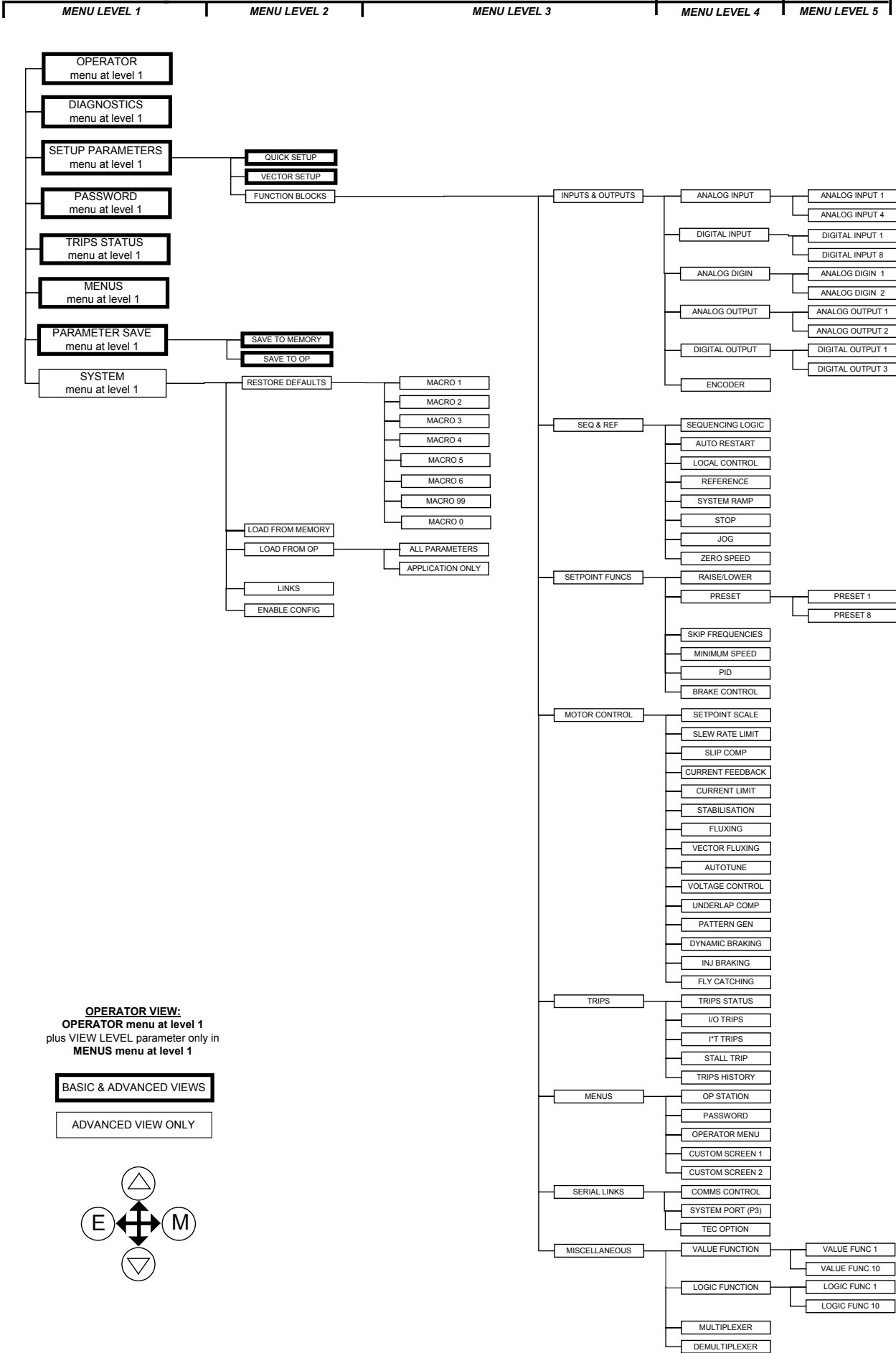

**OPERATOR VIEW:**  
**OPERATOR** menu at level 1  
 plus VIEW LEVEL parameter only in  
**MENUS** menu at level 1

**BASIC & ADVANCED VIEWS**  
 ADVANCED VIEW ONLY

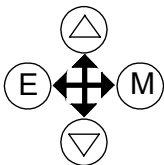

# 5-6 The Operator Station

## Changing a Parameter Value

Refer back to “The Menu System Map” to see how the menu is mapped.

Each menu contains parameters.

With the Parameter you want on view, press **M** to begin editing.

The up ( $\Delta$ ) and down ( $\nabla$ ) keys will now change the parameter/function value.

Press **E** to finish editing.

The four keys will once again navigate around the Menus. Refer back to “Navigating the Menu System”, page 5-4.

**Note:** When viewing a “number” value, i.e. 100.00%, pressing the **M** key moves the cursor along the number for editing of that character by the up ( $\Delta$ ) and down ( $\nabla$ ) keys. “Alphanumeric” values, i.e. PUMP 2, are produced and edited in a similar way.

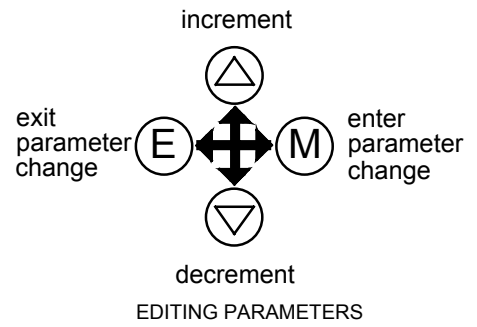

## What do the Symbols mean next to some Parameters?

### Parameter Status Information → ← =

→	Pressing <b>M</b> in a parameter displays → on the left of the bottom line to indicate that the up and down keys will now change parameter values. Pressing <b>E</b> removes the symbol and reverts the up and down keys to scrolling through the parameters.
←	A writable parameter may be non-writable if it is the destination of a link. In this case it will be indicated by ← appearing on the left of the bottom line.
=	Non-writable parameters are identified by = appearing on the left of the bottom line. <i>Note that some parameters become non-writable when the Inverter is running.</i>

### Expanded Menu Information >>

The parameters listed below are followed by >> to the right of the bottom display line indicating that there is more information. Press the **M** key to display a further list of parameters.

*AUTO RESTART menu at level 4:* AR TRIGGERS 1, AR TRIGGERS+ 1, AR TRIGGERS 2  
AR TRIGGERS+ 2

*TRIPS STATUS menu at level 4:* DISABLED TRIPS, DISABLED TRIPS+,  
ACTIVE TRIPS, ACTIVE TRIPS+,  
TRIP WARNINGS, TRIP WARNINGS+

*OP STATION menu at level 4:* ENABLED KEYS

## Alert Message Displays

A message will be displayed on the Operator Station when either:

- A requested operation is not allowed.  
*The top line details the illegal operation, while the bottom line gives the reason or cause. See example opposite.*
- The Inverter has tripped.  
*The top line indicates a trip has occurred while the bottom line gives the reason for the trip. See example opposite.*

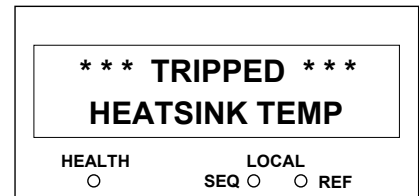
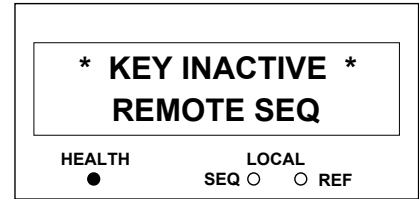

Most messages are displayed for only a short period, or for as long as an illegal operation is tried, however, trip messages must be acknowledged by pressing the **E** key.

Experience will show how to avoid most messages. They are displayed in clear, concise language for easy interpretation. Refer to Chapter 7: “Trips and Fault Finding” for trip messages and reasons.

## The PROG Key

The **PROG** key toggles between the OPERATOR menu and any other menu, remembering and returning to previous positions in each menu. As you press the **PROG** key, the title of the menu you are about to enter is displayed, i.e. OPERATOR or for example TRIPS. Releasing the key clears the display and releases you into that menu.

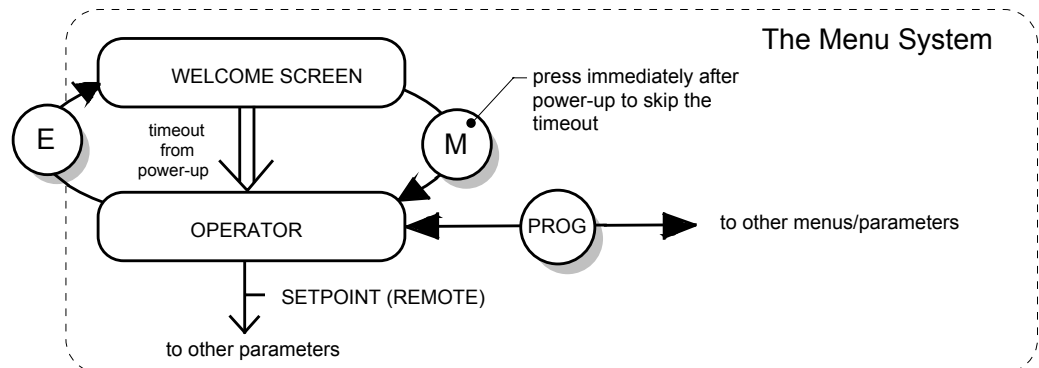

Figure 5-2 The Menu System showing Operation of the E, M and PROG Keys

## The L/R Key

The **L/R** key (LOCAL/REMOTE) toggles between Remote and Local Control. In doing so, the view of the SETPOINT parameter in the OPERATOR menu toggles between LOCAL SETPOINT and REMOTE SETPOINT. The default is for the REMOTE SETPOINT parameter to be displayed.

**Note:** A different naming convention is applied in the OPERATOR menu for these parameters when displayed as the first parameter entry:

- REMOTE SETPOINT is displayed as SETPOINT (REMOTE)
- LOCAL SETPOINT is displayed as SETPOINT (LOCAL)
- COMMS SETPOINT is displayed as SETPOINT (COMMS)

Pressing the L/R key when in Remote mode takes you directly to the SETPOINT (LOCAL) parameter with the Edit mode enabled. Press the PROG key to return to the previous display.

## The MMI DIAGNOSTICS Menu

<b>SPEED DEMAND</b> Actual speed demand.	<b>Tag No. 255</b>	<b>xxx.xh%</b>
	<i>(Refer to the REFERENCE function block)</i>	
<b>REMOTE SETPOINT</b> Target remote reference used when ramping in remote reference mode.	<b>Tag No. 245</b>	<b>-300.00 to 300.00 %</b>
	<i>(Refer to the REFERENCE function block)</i>	
<b>COMMS SETPOINT</b> Target reference used when ramping in remote reference Comms mode.	<b>Tag No. 269</b>	<b>-300.00 to 300.00 %</b>
	<i>(Refer to the REFERENCE function block)</i>	
<b>LOCAL SETPOINT</b> The Operator Station setpoint.	<b>Tag No. 247</b>	<b>0.00 to 100.00 %</b>
	<i>(Refer to the REFERENCE function block)</i>	
<b>JOG SETPOINT</b> Target reference used when ramping in local or remote reference Jog mode.	<b>Tag No. 246</b>	<b>0.00 to 100.00 %</b>
	<i>(Refer to the JOG function block)</i>	
<b>DRIVE FREQUENCY</b> The Inverter output frequency.	<b>Tag No. 591</b>	<b>xxx.xHz</b>
	<i>(Refer to the PATTERN GEN function block)</i>	
<b>ENCODER SPEED</b> Speed feedback in Hz.	<b>Tag No. 568</b>	<b>xxxx.xHz</b>
	<i>(Refer to the ENCODER function block)</i>	
<b>ENCODER SPEED</b> Speed feedback in RPM	<b>Tag No. 569</b>	<b>xxxxx n/min</b>
	<i>(Refer to the ENCODER function block)</i>	
<b>ENCODER SPEED</b> Speed feedback as a percentage of MAXIMUM SPEED.	<b>Tag No. 749</b>	<b>xxx.xx%</b>
	<i>(Refer to the ENCODER function block)</i>	
<b>MOTOR CURRENT</b> Level of rms line current being drawn from the Inverter.	<b>Tag No. 67</b>	<b>xxxx.xA</b>
	<i>(Refer to the CURRENT FEEDBACK function block)</i>	
<b>LOAD</b> Normalised version of the I TORQUE diagnostic: 100% = motor operating at rated load (torque).	<b>Tag No. 207</b>	<b>xxx.xx%</b>
	<i>(Refer to the CURRENT FEEDBACK function block)</i>	
<b>FIELD</b> Normalised version of the MOTOR CURRENT diagnostic: 100% = motor operating at rated magnetic flux (field).	<b>Tag No. 73</b>	<b>xxx.xh%</b>
	<i>(Refer to the CURRENT FEEDBACK function block)</i>	
<b>CURRENT LIMITING</b> Indicates if current limit is active (altering Inverter output frequency).	<b>Tag No. 370</b>	<b>FALSE / TRUE</b>
	<i>(Refer to the CURRENT LIMIT function block)</i>	
<b>BRAKING</b> Indicates the state of the brake switch.	<b>Tag No. 81</b>	<b>FALSE / TRUE</b>
	<i>(Refer to the DYNAMIC BRAKING function block)</i>	
<b>DC LINK VOLTS</b> The internal dc voltage being tested by the braking block.	<b>Tag No. 75</b>	<b>xxxx.xV</b>
	<i>(Refer to the CURRENT FEEDBACK function block)</i>	
<b>ACTIVE TRIPS</b> Indicates which trips are currently active.	<b>Tag No. 4</b>	<b>0000 to FFFF</b>
	<i>(Refer to the TRIPS STATUS function block)</i>	
<b>ACTIVE TRIPS+</b> Indicates which trips are currently active.	<b>Tag No. 740</b>	<b>0000 to FFFF</b>
	<i>(Refer to the TRIPS STATUS function block)</i>	

<b>FIRST TRIPS</b>	<b>Tag No. 6</b>	<i>enumerated</i>
Indicates the source of the first trip from when a trip occurs. <i>(Refer to the TRIPS STATUS function block)</i>		
<b>AIN 1 VALUE</b>	<b>Tag No. 16</b>	<b>xxx.xx%</b>
The input reading with scaling and input applied. <i>(Refer to the ANALOG INPUT function block)</i>		
<b>AIN 2 VALUE</b>	<b>Tag No. 25</b>	<b>xxx.xx%</b>
The input reading with scaling and input applied. <i>(Refer to the ANALOG INPUT function block)</i>		
<b>AIN 3 VALUE</b>	<b>Tag No. 715</b>	<b>xxx.xx%</b>
The input reading with scaling and input applied. <i>(Refer to the ANALOG INPUT function block)</i>		
<b>AIN 4 VALUE</b>	<b>Tag No. 722</b>	<b>xxx.xx%</b>
The input reading with scaling and input applied. <i>(Refer to the ANALOG INPUT function block)</i>		
<b>DIN 1 VALUE</b>	<b>Tag No. 31</b>	<b>FALSE / TRUE</b>
The TRUE or FALSE input (after any inversion). <i>(Refer to the DIGITAL INPUT function block)</i>		
<b>DIN 2 VALUE</b>	<b>Tag No. 34</b>	<b>FALSE / TRUE</b>
The TRUE or FALSE input (after any inversion). <i>(Refer to the DIGITAL INPUT function block)</i>		
<b>DIN 3 VALUE</b>	<b>Tag No. 37</b>	<b>FALSE / TRUE</b>
The TRUE or FALSE input (after any inversion). <i>(Refer to the DIGITAL INPUT function block)</i>		
<b>DIN 4 VALUE</b>	<b>Tag No. 40</b>	<b>FALSE / TRUE</b>
The TRUE or FALSE input (after any inversion). <i>(Refer to the DIGITAL INPUT function block)</i>		
<b>DIN 5 VALUE</b>	<b>Tag No. 43</b>	<b>FALSE / TRUE</b>
The TRUE or FALSE input (after any inversion). <i>(Refer to the DIGITAL INPUT function block)</i>		
<b>DIN 6 VALUE</b>	<b>Tag No. 726</b>	<b>FALSE / TRUE</b>
The TRUE or FALSE input (after any inversion). <i>(Refer to the DIGITAL INPUT function block)</i>		
<b>DIN 7 VALUE</b>	<b>Tag No. 728</b>	<b>FALSE / TRUE</b>
The TRUE or FALSE input (after any inversion). <i>(Refer to the DIGITAL INPUT function block)</i>		
<b>DIN 8 VALUE</b>	<b>Tag No. 730</b>	<b>FALSE / TRUE</b>
The TRUE or FALSE input (after any inversion). <i>(Refer to the DIGITAL INPUT function block)</i>		
<b>AOUT 1 VALUE</b>	<b>Tag No. 45</b>	<b>-300.00 to 300.00%</b>
The demanded value to output. <i>(Refer to the ANALOG OUTPUT function block)</i>		
<b>AOUT 2 VALUE</b>	<b>Tag No. 731</b>	<b>-300.00 to 300.00%</b>
The demanded value to output. <i>(Refer to the ANALOG OUTPUT function block)</i>		
<b>DOUT1 VALUE</b>	<b>Tag No. 52</b>	<b>FALSE / TRUE</b>
The True or False output demand. <i>(Refer to the DIGITAL OUTPUT function block)</i>		
<b>DOUT 2 VALUE</b>	<b>Tag No. 55</b>	<b>FALSE / TRUE</b>
The True or False output demand. <i>(Refer to the DIGITAL OUTPUT function block)</i>		
<b>DOUT 3 VALUE</b>	<b>Tag No. 737</b>	<b>FALSE / TRUE</b>
The True or False output demand. <i>(Refer to the DIGITAL OUTPUT function block)</i>		

## Special Menu Features

### Menu Shortcuts and Special Key Combinations

#### Quick Link Information

When in Advanced view level, pressing the **M** key for approximately 3 seconds in any parameter will display link information about that parameter (a message may be displayed during this time). The information is displayed in the following format:

325 - - - 7 -> [245]

Source tag number

Link number

Destination tag number

**Note:** *The Inverter must be in Configuration mode before links can be edited. However, holding the **M** key down in Parameterisation mode will allow the information to be displayed but the information disappears when the key is released.*

Use the up (**Δ**) and down (**∇**) keys to change the source tag number. If the source number is changed from zero, the next available link number will be assigned. Press **E** twice to clear the link information and return to the parameter.

All link information is also available through the menu LINKS, menu at level 2.

#### Quick Save to Memory

Holding down the **PROG** key for about 2 seconds quickly takes you to the SAVE TO MEMORY menu in the PARAMETER SAVE menu at level 1.

After saving, press the **PROG** key to return to the previous display.

#### Changing the Display Language

Holding down the **PROG** key at power-up takes you immediately to the DISPLAY LANGUAGE parameter in the MENUS menu at level 1.

Refer to “Selecting the Display Language”, page 5-12 for information on selecting a language.

The selected view level (when previously powered-down) determines how you will exit the parameter:

- Operator: releases you into the OPERATOR menu at level 1
- Basic: releases you into the MENUS menu at level 1
- Advanced: releases you into the MENUS menu at level 1

#### Quick Drive Copy

With an application stored in the Operator Station (refer to “Copying an Application”, page 5-14), holding the down (**∇**) key at power-up takes you immediately to the ALL PARAMETERS display in the LOAD FROM OP menu at level 2. The Advanced view mode is automatically selected.

**ALL PARAMETERS  
`UP` FOR ACTION**

HEALTH LOCAL  
○ SEQ ○ ○ REF

**Note:** *Pressing the up (**Δ**) key, as instructed, copies all parameter settings including motor specific data from the Operator Station to the Inverter.*

The Operator Station will still contain the application data, allowing transfer to successive units. This information is replaced by any subsequent SAVE TO OP operation.

## Changing the Product Code

On rare occasions it may be necessary to change the default settings by changing the Product Code. The Product Code is referred to in Chapter 2. You can select a different Language field (with associated frequency) and power rating for the Inverter; other information is automatically read from the power board.

A special key combination is required to change the product code. This feature is only available at power-up as a security measure.

- Hold down the **Δ**, **E** and **PROG** keys, then power-up the Inverter

An alert message may be displayed, “ALERT CONFIG MODE”. This is warning you that you have initialised the Operator Station into the configuration mode and therefore parameters can be changed.

- Use the up (**Δ**) and down (**∇**) keys to select a default setting
- Hold down the **E** key to exit

The new settings will be saved automatically, and all defaults will be restored.

**Note:** Holding down the **Δ**, **E** and **PROG** keys whilst displaying the Welcome screen will also display the product code, but you will be unable to change the parameter. To go to the Welcome screen, press the **PROG** key until you enter the Operator menu system, then press the **E** key until the Welcome screen is displayed.

## Quick Restore Default

A special key combination restores to the Inverter the current product code default values and Macro 1 parameter values. This feature is only available at power-up as a security measure.

- Hold down the up (**Δ**) and down (**∇**) and keys, then power-up the Inverter.

## Menu Viewing Levels

For ease of operation, there are three `viewing levels` for the Operator Station. The setting for the viewing level decides how much of the menu system will be displayed.

The choice of menu for each has been designed around a type of user, hence we have the Operator, Basic and Advanced viewing levels.

**Note:** The contents of the OPERATOR menu remains unchanged for all view levels.

Refer to “The Menu System Map”, page 5-5 to see how the viewing level changes the displayed menu.

To change the viewing level, go to MENUS menu at level 1. The first parameter in this menu, VIEW LEVEL, selects the viewing level.

## Startup Screen Timeouts

Another action of selecting different viewing levels is to introduce a timeout to the Startup screen. By default, the Startup screen is the SETPOINT parameter, but you can select any parameter to be the Startup screen.

### Operator viewing level

The Startup screen will be displayed after an extended period without a key press when viewing the Welcome screen or the VIEW LEVEL parameter in the MENUS menu at level 1.

### Basic viewing level

There is no timeout

### Advanced viewing level

There is no timeout

# 5-12 The Operator Station

## Selecting the Display Language

There is an option to select a different display language without changing the product code information.

The choice of display language is selected by the LANGUAGE parameter in MENUS menu at level 1. Although the display language will change, the unit will still be operating with the existing product code information. Remember to use the SAVE TO MEMORY parameter if you need the new language to be saved on power-down.

The available languages are: ENGLISH, FRENCH, GERMAN, SPANISH.

## Control Key Enable/Disable

The ENABLED KEYS parameter, in the OP STATION menu at level 4, allows you to enable and disable the control keys on the front of the Operator Station. This may be very important in situations where say, changing the direction of the Inverter could have disastrous results.

Refer to Chapter 6: “Programming Your Application “ - OP STATION.

## Password Protection

When in force, the password prevents unauthorised parameter modification by making all parameters “read-only”. If you attempt to modify a password protected parameter, it will cause an ‘alert/reason’ message to be displayed. By default, the password feature is disabled, i.e. 0000.

There are two password parameters, stored in the PASSWORD menu at level 1: ENTER PASSWORD and CHANGE PASSWORD.

The ENTER PASSWORD and CHANGE PASSWORD values are hidden by “XXXX” until you press the M key to begin editing the parameter.

### To Activate Password Protection

1. Use the  $\Delta$  and  $\nabla$  keys in the CHANGE PASSWORD parameter to set a password (anything other than 0000). Press the E key to exit the parameter.

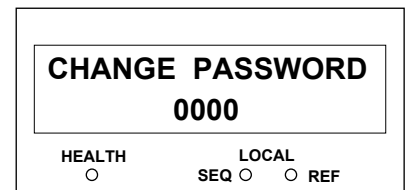

1. Move to the ENTER PASSWORD parameter. Enter any number other than the password and press the E key to exit. The system is now ‘password locked’.

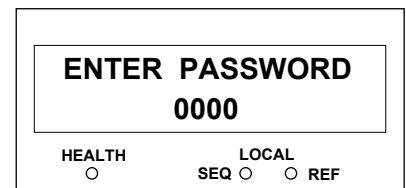

Having activated the password protection, you can no longer edit the CHANGE PASSWORD parameter until you deactivate the password protection.

### To Deactivate Password Protection

Enter the current password in the ENTER PASSWORD parameter. Press the E key to exit.

**Note:** You can also choose to have the password protect the entire OPERATOR menu, or just the SETPOINT (LOCAL) parameter. Under default conditions these are not protected. Refer to Chapter 6: “Programming Your Application” - PASSWORD.

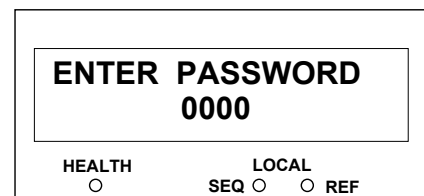

## Selecting Parameters for the Operator Menu

The diagram below shows the default view of this menu.

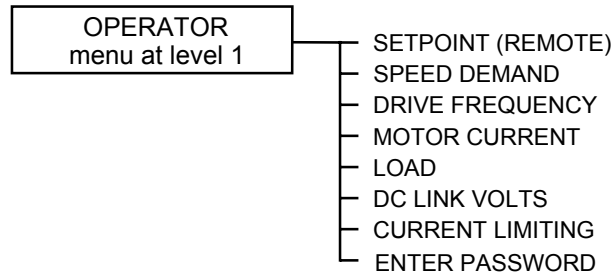

The selected “view level” has no effect on this menu, it is always available.

The default setting for the OPERATOR menu is to display 8 parameters, however it actually contains 16 parameters. Except for parameter No. 1 which is fixed as the SETPOINT parameter and the last parameter which is always ENTER PASSWORD, the remaining 14 parameters can be changed to display any diagnostic or configurable parameter, (also refer to “Creating Custom Screens”).

1. Select the OPERATOR MENU at level 4. To view this menu the Operator Station must have ADVANCED view level selected.
2. Press the **M** key to reveal the STARTUP SCREEN parameter (this is described below).

Press the down (**∇**) arrow to display the OPERATOR MENU 2 parameter. You select a parameter for display by entering its tag number into one of the OPERATOR MENU parameters; press the **M** key and use the up (**Δ**) and down (**∇**) keys to set the tag number. Press the **E** key to exit the parameter.

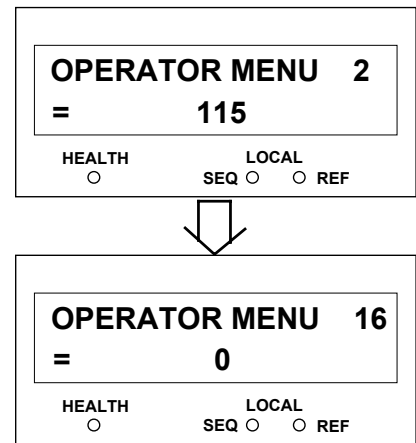

For more details on customising this menu to your application refer to Chapter 6: “Programming Your Application” - OPERATOR MENU.

## Selecting a Startup Screen

The STARTUP SCREEN parameter selects which of the OPERATOR MENU parameters will be used as the Startup screen. Press the **M** key and use the up (**Δ**) and down (**∇**) keys to set the screen number. Press the **E** key to exit the parameter. The example shown has OPERATOR MENU 1 selected (this is the “fixed” OPERATOR MENU parameter that always displays the SETPOINT parameter). Setting the STARTUP SCREEN to an OPERATOR MENU parameter whose tag number is set to zero will cause the STARTUP SCREEN to revert to OPERATOR MENU 1.

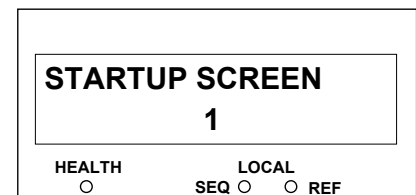

## Customising the Welcome Screen

You can edit the top line of the start-up screen to display a useful and/or personalised message.

1. Select the CONFIGURATION ID menu at level 3. To view this menu the Operator Station must have ADVANCED view level selected.
2. Use the up (**Δ**) and down (**∇**) keys to scroll through the character set for each of the 16 character spaces. Press the **M** key to move to the next character. Press the **E** key to exit the parameter.

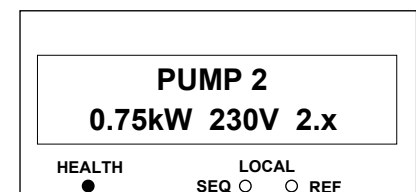

# 5-14 The Operator Station

## Creating Custom Screens

You can create two “custom screens”, which can be very useful when added to the OPERATOR menu.

Each screen contains:

- a top line of sixteen characters
- user-definable units
- user-selectable scaling factor
- user-selectable limits
- user-selectable coefficients

This feature may be used to re-display the setpoint, for example, in more convenient units. Refer to Chapter 6: “Programming Your Application” - CUSTOM SCREEN.

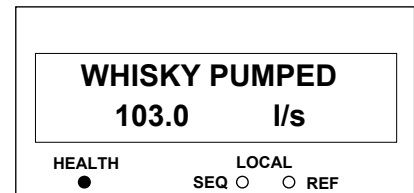

## How to Save, Restore and Copy your Settings

### Saving Your Application

The PARAMETER SAVE menu at level 1, only available in the Basic and Advanced view levels, provides two save options:

1. SAVE TO MEMORY menu at level 2: saves to non-volatile memory within the Inverter
2. SAVE TO OP menu at level 2: saves to the Operator Station

**Note:** The SAVE TO OP function produces a copy of the Inverter’s setup, including all user options and the current password, refer to “Copying an Application” below.

### Restoring Saved Settings

If you are unsure about any changes you have made, you can re-load the last saved setup from memory. Enter the LOAD FROM MEMORY menu at level 2 to display the ‘UP’ FOR ACTION page.

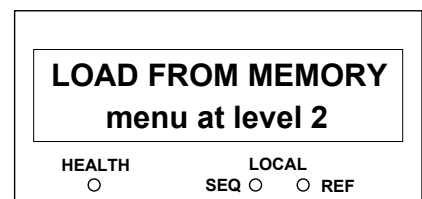

**Note:** Pressing the  $\Delta$  key, as instructed, restores to the Inverter the last saved parameter settings.

### Copying an Application

The Operator Station is a programming tool for writing to the Inverter, where the information is stored. But the Operator Station itself can also be used to store this data.

### Transferring Your Application to Another Inverter

**Note:** The Inverter you are copying to must have the same (or a newer software) release. Refer to the Welcome screen (power-up).

1. Write the application to the Operator Station via the SAVE TO OP menu at level 2. To view the SAVE TO OP menu the Operator Station must have Basic or Advanced view level selected.
2. Connect the Operator Station to the receiving Inverter.
3. Select Advanced view level, if necessary. Transfer the data via the LOAD FROM OP menu at level 2. Two sub-menus allow you to choose between loading a full parameter load which includes motor-specific data, or just the application without any motor-specific data:

ALL PARAMETERS  
APPLICATION ONLY

Refer to Chapter 6: “Programming Your Application” - Motor-Specific Parameters.

**Note:** Both methods will transfer the password of the host unit. Refer to "Password Protection", page 5-12.

The Operator Station still has the application data stored allowing transfer to successive units. This information is replaced by any subsequent SAVE TO OP operation.

## **Backing-up Your Application**

The Operator Station can be used to back-up the application data stored in the Inverter as a safety measure. Refer to "Transferring Your Application to Another Inverter" above.

You can have the Operator Station back-up the application each time a SAVE TO MEMORY is performed by enabling the AUTO BACKUP parameter. Refer to Chapter 6: "Programming Your Application" - OP STATION.

# 5-16 The Operator Station

# PROGRAMMING YOUR APPLICATION

## Introducing the Macro

You can program the Inverter for specific applications.

The Inverter is supplied with macros (set-ups) which can be used as starting points for application-specific programming. This programming could simply involve the inputting of parameter values, or it may require the making or breaking of programmable links, which is a feature of this unit.

Each macro instantly recalls a pre-programmed set of default parameters when it is loaded.

Refer to Chapter 15: “Application Macros” for further information.

## Programming with Block Diagrams

Block diagram programming provides a visual method of planning the software to suit your application. There are block diagrams provided at the end of this chapter, each showing the software connections for an application macro.

The processes performed by a macro are represented as a block diagram, consisting of *function blocks* and *links*:

- Each function block contains the parameters required for setting-up a particular processing feature. Sometimes more than one function block is provided for a feature, i.e. for multiple digital inputs.
- Software links are used to connect the function blocks. Each link transfers the value of an output parameter to an input parameter of another (or the same) function block.

Each individual block is a processing feature, i.e. it takes the input parameter, processes the information, and makes the result available as one or more output parameters.

## Modifying a Block Diagram

### Configuration and Parameterisation Modes

There are two modes of operation used while modifying a block diagram: *Parameterisation* and *Configuration* modes.

The ENABLE CONFIG and DISABLE CONFIG commands, found under SYSTEM menu at level 1, is used to toggle between these two modes of operation.

DEFAULT

#### Parameterisation Mode

In parameterisation mode you can change parameter values. The Inverter can be running or stopped. Note that some parameters can only be changed when the Inverter is stopped. It is not possible to modify the internal links when the Inverter is in parameterisation mode.

#### Configuration Mode

In the configuration mode you can modify the links in the function block diagram. You can also change parameter values, as above. This mode is indicated by all the LEDs on the operator station flashing at once. The Inverter cannot run in this mode.

### Making and Breaking Links in Configuration Mode

Links can be moved, added or deleted from a block diagram whilst in the Configuration mode. There are 50 links available, each has its own identification number (“link” number). You make a link by setting the link’s “source” and “destination” tags to be the two parameter tag numbers to be linked. The outputs of function blocks are not updated whilst in this mode.

## 6-2 Programming Your Application

### Programming Rules

The following rules apply when programming:

#### Parameterisation Mode

- Function block output parameter values cannot be changed (because they are a result of the function block's processing)
- Function block input parameter values that receive their values from a link cannot be changed (as they will change back to the value they receive from the link when the Inverter is running).

#### Configuration Mode

- A link's destination tag must be set to an input parameter (only one link per input parameter).
- A link's source tag may be set to any parameter. Both input and output parameters can be used as a source.
- Disable a link by setting the "destination" and "source" tag to zero.
- Setting a link's source tag to a negative value (i.e. 18 becomes -18) nominates it as a *feedback link*, forcing this link to be executed first. This is used to reduce execution timing delays in a feedback loop situation.

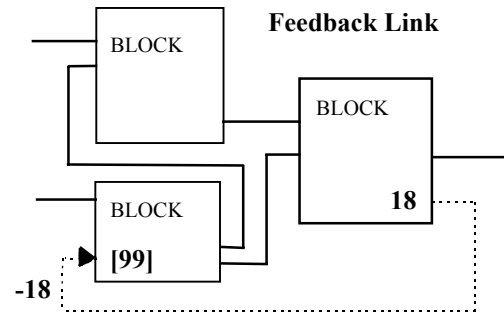

**Figure 6-1 Quick Link Information:**  
-18 .. (-) → [99]

### Execution Rules

The complete block diagram is executed every 20ms, with individual control blocks executing within 2ms. Just before a function block is executed, all the links that have that block as their destination are executed, thereby copying new values in to the block's parameter inputs. The input parameters are then processed to produce a new set of output parameters. The execution order of the blocks is automatically arranged for minimal delay.

- The output value transferred by a link on execution is clamped to be between the maximum and minimum value for its destination input parameter.
- If a link's source and destination parameters have different decimal point positions, there is no automatic adjustment. Use a VALUE FUNCTION block to modify the input into the correct destination format. Refer to the table below for the result of linking different parameters types.

Source Value (the input)	Source Format	Destination Format	Destination Value (the result)
100.00	XXX.XX	XXXX.X	1000.0
100.00	XXX.XX	X.XXXX	1.0000
TRUE	Boolean	XXX.XX	0.01
FALSE	Boolean	XXX.XX	0.00
0.01	XXX.XX	Boolean	TRUE
0.00	XXX.XX	Boolean	FALSE
LOCAL ONLY (1)	Enumerated	XXX.XX	0.01
0.02	XXX.XX	Enumerated	REMOTE ONLY (2) Note that (2) will not always return Remote Only

**Table 6-1 Execution Rules**

**Note:** Check the source and destination formats from the Function Block diagrams and/or Chapter 10: "Parameter Specification Tables" because the Operator Station displays some parameters with the least significant digit suppressed.

## Saving Your Modifications

If parameter values or links have been modified or a macro has been loaded, the new settings must be saved. The Inverter will then retain the new settings during power-down. Refer to Chapter 5: "The Operator Station" - Saving Your Application.

## Understanding the Function Block Description

The following function blocks show the parameter information necessary for programming the Inverter. The diagrams assume that the UK country code is selected and that a 400V 0.75kW power board is fitted.

Input parameters are shown on the left hand side, and output parameters are shown on the right hand side of the block.

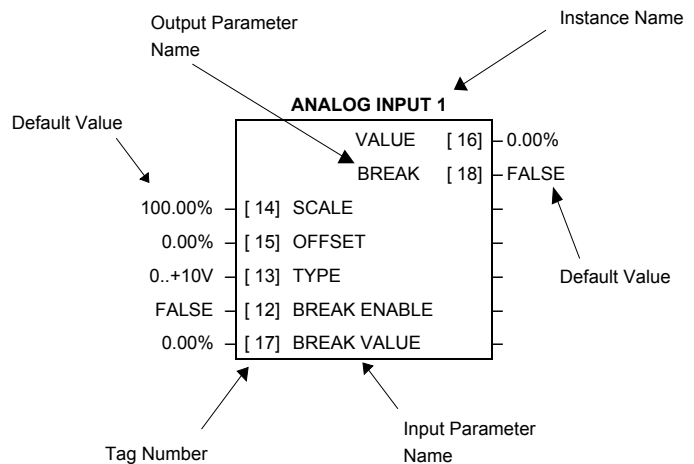

**Figure 6-2 Function Block Parameter Information**

<b>Instance Name</b>	Names the function block type
<b>Default Value</b>	The default value of the unmodified macro, Macro 0
<b>Input/Output Parameter Name</b>	The name shown on ConfigEd Lite
<b>Tag Number</b>	Unique identification used for linking and communications
<b>*</b>	Parameters marked with "*" are set to a value depending on the <i>Language</i> portion of the product code. Refer to Chapter 2: "Understanding the Product Code" and Chapter 10: "Product-Related Default Values".
<b>**</b>	Parameters marked with "**" are set to a value depending on the overall "power build" of the Inverter indicated by the product code. Refer to Chapter 2: "Understanding the Product Code" and Chapter 10: "Product - Related Default Values"

**Note:** *Decimal Places (dp)* - some internally-held parameters with two decimal places are only displayed with one decimal place. These parameters are indicated in the Parameter Descriptions tables. The Range parameter shows the hidden character as "h", i.e. xxx.xh.

### MMI Menu Map

- 1 SETUP PARAMETERS
- 2 FUNCTION BLOCKS
- 3 INPUTS & OUTPUTS
- 4 ANALOG INPUT
- 4 ANALOG INPUT 1
- 4 ANALOG INPUT 2
  - AIN 2 SCALE
  - AIN 2 OFFSET
  - AIN 2 TYPE
  - AIN 2 BREAK ENBL
  - AIN 2 BREAK VAL
  - AIN 2 VALUE
  - AIN 2 BREAK

## MMI Menu Maps

The function block descriptions include an easy-find menu showing the menu levels and titles encountered to find the appropriate menu title, and the parameters contained in the menu(s).

The menu maps are shown as if the Advanced view level is selected.

Where there is more than one sub-menu, i.e. ANALOG INPUT as illustrated, the parameters shown will be for the last sub-menu. In many cases, these parameters will reflect the name and number of the last sub-menu.

Because of this intuitive naming of parameters, which is designed to make using the Operator Station easier, MMI parameter names may vary slightly from Function Block names.

## 6-4 Programming Your Application

### Hexadecimal Representation of Trips

The ACTIVE TRIPS, WARNINGS, DISABLED TRIPS, TRIGGERS 1 and TRIGGERS 2 parameters use a four digit hexadecimal number to identify individual trips. Each trip has a unique corresponding number as shown below.

Trip		Trip Code			
		Digit 4	Digit 3	Digit 2	Digit 1
1	LINK OVERVOLTS				1
2	LINK UNDERVOLT				2
3	OVERCURRENT				4
4	HEATSINK TEMP				8
5	EXTERNAL TRIP			1	
6	INPUT 1 BREAK			2	
7	INPUT 2 BREAK			4	
8	MOTOR STALLED			8	
9	I*T TRIP		1		
10	BRAKE RESISTOR		2		
11	BRAKE SWITCH		4		
12	OP STATION		8		
13	LOST COMMS	1			
14	Not used	2			
15	Not used	4			
16	Not used	8			

The ACTIVE TRIPS+, WARNINGS+, DISABLED TRIPS+, TRIGGERS+ 1 and TRIGGERS+ 2 parameters use a four digit hexadecimal number to identify individual trips. Each trip has a unique corresponding number as shown below.

Trip		Trip Code			
		Digit 4	Digit 3	Digit 2	Digit 1
17	MOTOR TEMP				1
18	CURRENT LIMIT				2
19	SHORT CIRCUIT				4
20	24V FAILURE				8
21	LOW SPEED I			1	
22	PHASE FAIL			2	

When more than one trip is to be represented at the same time then the trip codes are simply added together to form the value displayed. Within each digit, values between 10 and 15 are displayed as letters A to F

For example, if the ACTIVE TRIPS parameter is **01A8** then this represents a “1” in digit 3, an “8” and a “2” in digit 2, (8+2 = 10, displayed as A), and an “8” in digit 1. This in turn represents the active trips I\*T TRIP, MOTOR STALLED, INPUT 1 BREAK and HEATSINK TEMP, (an unlikely situation).

Decimal number	Display
10	A
11	B
12	C
13	D
14	E
15	F

## Function Block Descriptions

The following function block descriptions are arranged in alphabetical order. They each appear as a Menu in the FUNCTION BLOCKS menu at level 2.

**Note:** Remember to select the correct mode, Parameterisation or Configuration, whilst editing. Refer back to "Modifying a Block Diagram", page 6-1. You must select the Advanced view level to see the FUNCTION BLOCKS menu at level 2, go to MENUS menu at level 1.

Function Block	Page	Function Block	Page
ANALOG DIGIN	6-6	OPERATOR MENU	6-43
ANALOG INPUT	6-8	OP STATION	6-44
ANALOG OUTPUT	6-11	PASSWORD	6-46
AUTO RESTART	6-13	PATTERN GEN	6-47
AUTOTUNE	6-15	PID	6-48
BRAKE CONTROL	6-16	PRESET	6-50
COMMS CONTROL	6-17	RAISE/LOWER	6-52
CURRENT FEEDBACK	6-18	REFERENCE	6-53
CURRENT LIMIT	6-20	SEQUENCING LOGIC	6-55
CUSTOM SCREEN	6-21	SETPOINT SCALE	6-56
DEMULTIPLEXER	6-23	SKIP FREQUENCIES	6-58
DIGITAL INPUT	6-24	SLEW RATE LIMIT	6-60
DIGITAL OUTPUT	6-25	SLIP COMP	6-61
DYNAMIC BRAKING	6-26	STABILISATION	6-62
ENCODER	6-27	STALL TRIP	6-63
FLUXING	6-28	STOP	6-64
FLYCATCHING	6-30	SYSTEM PORT (P3)	6-65
INJ BRAKING	6-32	SYSTEM RAMP	6-66
I/O TRIPS	6-33	TEC OPTION	6-68
I*† TRIP	6-34	TRIPS HISTORY	6-69
JOG	6-35	TRIPS STATUS	6-70
LOCAL CONTROL	6-36	UNDERLAP COMP	6-72
LOGIC FUNCTION	6-37	VALUE FUNCTION	6-73
MINIMUM SPEED	6-41	VECTOR FLUXING	6-80
MULTIPLEXER	6-42	VOLTAGE CONTROL	6-81
		ZERO SPEED	6-82

# 6-6 Programming Your Application

## MMI Menu Map

- 1 SETUP PARAMETERS
- 2 FUNCTION BLOCKS
- 3 INPUTS & OUTPUTS
- 4 ANALOG DIGIN
- 5 ANALOG DIGIN 1
- 5 ANALOG DIGIN 2
  - A DIN 2 INVERT
  - A DIN 2 LEVEL
  - A DIN 2 HYST
  - A DIN 2 VALUE

## ANALOG DIGIN

The analog digital input block allows the analog input terminals to be used as digital input signals.

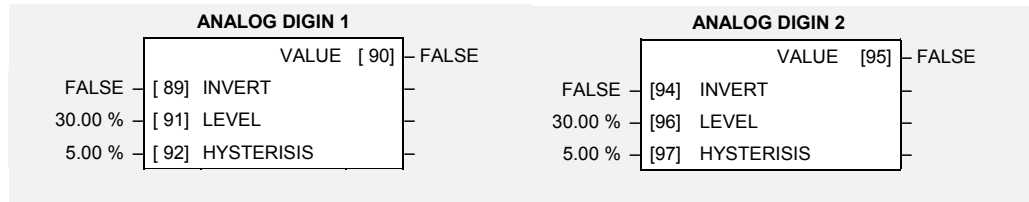

## Parameter Descriptions

### INVERT

Range: FALSE / TRUE

When this is TRUE, the VALUE output is inverted.

### LEVEL

Range: 0.00 to 100.00 %

This is the level used to determine whether the input is high or low. The actual level also depends on the hardware range selected.

### HYSTERISIS

Range: 0.00 to 50.00 %

A hysteresis value used to prevent jitter on the input. The actual hysteresis also depends on the hardware range selected.

### VALUE

Range: FALSE / TRUE

A TRUE or FALSE output depending on the input volts or current.

## Functional Description

The Inverter has two analog inputs. There is a digital analog input function block for each: ANALOG DIGIN 1 is associated with the signal on terminal 1, whilst ANALOG DIGIN 2 is associated with the signal on terminal 2.

The analog digital input function blocks allow the analog terminals to be used as digital inputs where extra digital inputs are required. The input voltage or current is converted to a TRUE or FALSE digital signal. Generally, (when INVERT is FALSE), an input greater than the comparison LEVEL will cause the output VALUE to be TRUE. Similarly, an input less than the comparison LEVEL will cause the output VALUE to be FALSE.

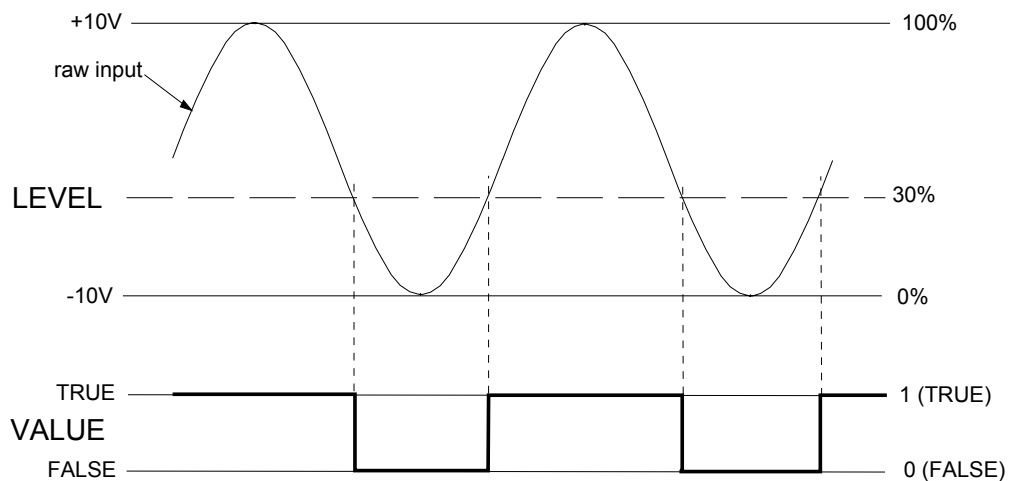

## Programming Your Application 6-7

HYSTERISIS is used to make the function block resistant to noise on the input. It operates so that if the last non-inverted output was TRUE then the comparison level used is  $LEVEL - HYSTERISIS$ . If the last non-inverted output was FALSE then the comparison level used is  $LEVEL + HYSTERISIS$ .

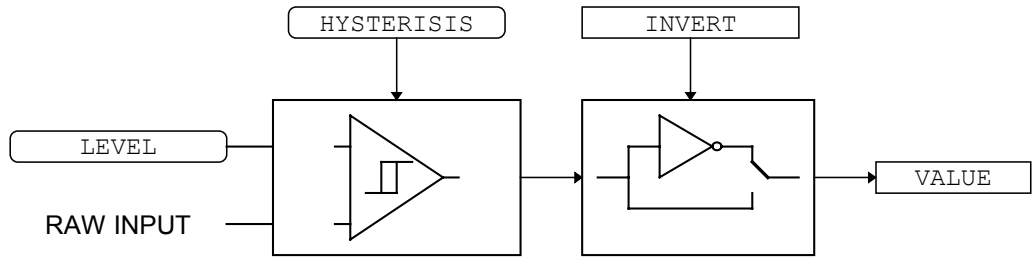

The input voltage or current is converted to an equivalent percentage by the Inverter's analog input electronics. The percentage generated by a given input voltage depends on the hardware range selected, as shown in the table below. The hardware range is selected using switch bank SW1 on the control PCB, as described under the ANALOG INPUT function block.

Nominal Hardware Range	Hardware Input	Equivalent %	Suggested Level
0 to 20mA	0mA	0%	22%
	20mA	44%	
-10 to 10V	-10V	0%	50%
	10V	100%	
0 to 10V	0V	0%	50%
	10V	100%	

# 6-8 Programming Your Application

## ANALOG INPUT

The analog input block converts the input voltage or current into a value expressed as a percentage of a configurable range.

**MMI Menu Map**

1	SETUP PARAMETERS
2	FUNCTION BLOCKS
3	INPUTS & OUTPUTS
4	ANALOG INPUT
5	ANALOG INPUT 1
5	ANALOG INPUT 2
5	ANALOG INPUT 3
5	ANALOG INPUT 4
	AIN 4 SCALE
	AIN 4 OFFSET
	AIN 4 TYPE
	AIN 4 BREAK ENBL
	AIN 4 BREAK VAL
	AIN 4 VALUE
	AIN 4 BREAK

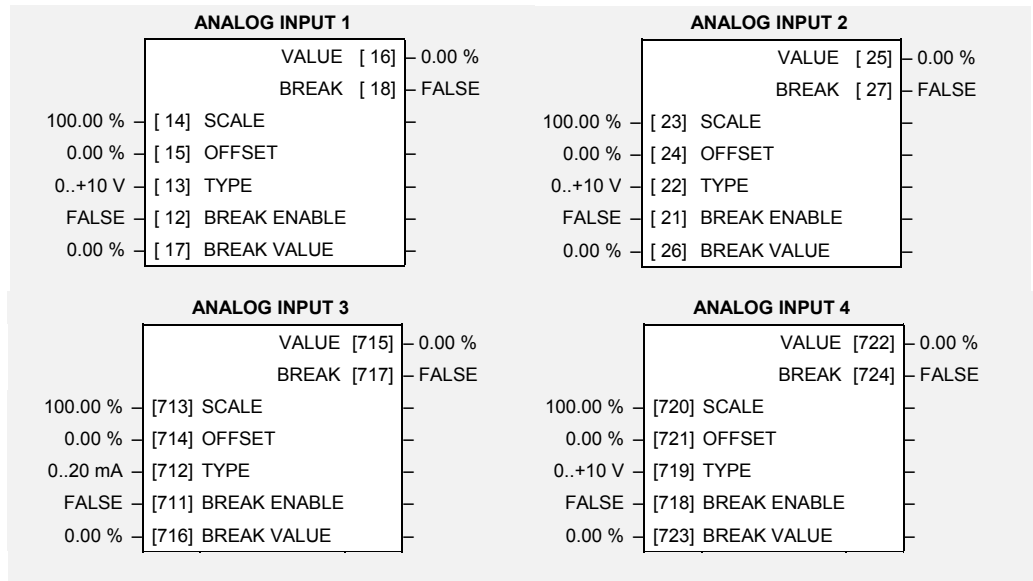

## Parameter Descriptions

### SCALE

*Range: -300.00 to 300.00 %*

A scaling factor applied to the raw input. With a scaling factor of 100.00% and an offset of 0.00%, an input equal to the low input range will appear as a value of 0.00%. Similarly, an input equal to the high input range will appear as a value of 100.00%.

### OFFSET

*Range: -300.00 to 300.00 %*

An offset added to the input after the scaling factor has been applied.

### TYPE

*Range: Enumerated - see below*

The input range and type.

- ANALOG INPUT 1 and ANALOG INPUT 2 can use all types.
- ANALOG INPUT 3 is used for current measurement only, if any voltage type is selected then VALUE will be set to zero.
- ANALOG INPUT 4 supports unipolar (positive) volts inputs only, if the bipolar or current types are selected then VALUE will be set to zero.

**Warning:** For correct operation, ensure that the hardware range selected using switch bank SW1 corresponds to the TYPE selected.

*Enumerated Value : Type*

- 0 : 0..+10 V
- 1 : +2..+10 V
- 2 : 0..+5 V
- 3 : +1..+5 V
- 4 : -10..+10 V
- 5 : 0..20 mA
- 6 : 4..20 mA
- 7 : 20..4 mA
- 8 : 20..0 mA

## BREAK ENABLE

Range: FALSE / TRUE

For input types that support sensor break detection, this parameter may be used to disable sensor break detection. For input types that do not support break detection, this parameter is FALSE.

## BREAK VALUE

Range: -300.00 to 300.00 %

The value that will appear as the VALUE output when BREAK is TRUE

## VALUE

Range: xxx.xx %

The input reading with scaling and offset applied.

## BREAK

Range: FALSE / TRUE

Indicates that the input sensor signal is not present. See below for more details on break detection.

## Functional Description

The Inverter has four analog inputs. There is an analog input function block for each:

- ANALOG INPUT 1 is associated with the signal on terminal 1
- ANALOG INPUT 2 is associated with the signal on terminal 2
- ANALOG INPUT 3 is associated with the signal on terminal 3
- ANALOG INPUT 4 is associated with the signal on terminal 5

The input voltage is pre-processed and converted into a numeric value by the analog input electronics of the Inverter. The analog input function blocks further process this reading so that a value of 0.00% represents an input equal to the low input range, while a value of 100.00% represents an input equal to the high input range. The SCALE and OFFSET factors are then applied as shown to produce a value suitable for use in the application.

The break detect facility may only be used in conjunction with the following hardware ranges: 2 to 10V, 1 to 5V, 4 to 20mA and 20 to 4mA. An input break is defined as an input reading less than either 0.1V or 0.45mA. When an input break has been detected, the VALUE output is forced to be the BREAK VALUE.

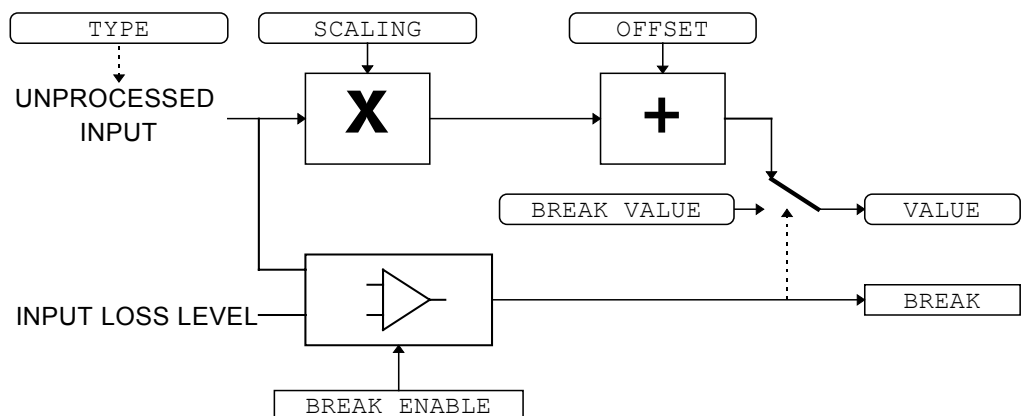

# 6-10 Programming Your Application

## Configuration Switch Settings (SW1)

The analog input terminals are configured for voltage or current operation by the I/O configuration switch settings. Remember to select the appropriate TYPE parameter.

Input	Type	Switch Settings
ANALOG INPUT 1 Terminal 1	0-20 or 4-20mA	SW1/1 OFF, SW1/2 ON
	0-10V*	SW1/1 OFF, SW1/2 OFF*
	± 10V	SW1/1 ON, SW1/2 OFF
ANALOG INPUT 2 Terminal 2	0-20 or 4-20mA	SW1/3 OFF, SW1/4 ON
	0-10V*	SW1/3 OFF, SW1/4 OFF*
	± 10V	SW1/3 ON, SW1/4 OFF
* Default settings, as shown		

Figure 6-3 I/O Configuration Switches shown at Manufacturing Defaults

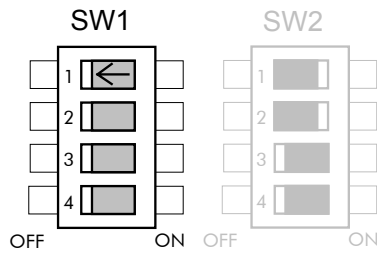

Table 6-2 Select Input Signal

## ANALOG OUTPUT

The analog output blocks converts the demand percentage into a form suitable for driving the analog output electronics of the Inverter.

**MMI Menu Map**

- 1 SETUP PARAMETERS
- 2 FUNCTION BLOCKS
- 3 INPUTS & OUTPUTS
- 4 ANALOG OUTPUT
- 5 ANALOG OUTPUT 1
- 5 ANALOG OUTPUT 2
  - AOUT 2 VALUE
  - AOUT 2 SCALE
  - AOUT 2 OFFSET
  - AOUT 2 ABS
  - AOUT 2 TYPE

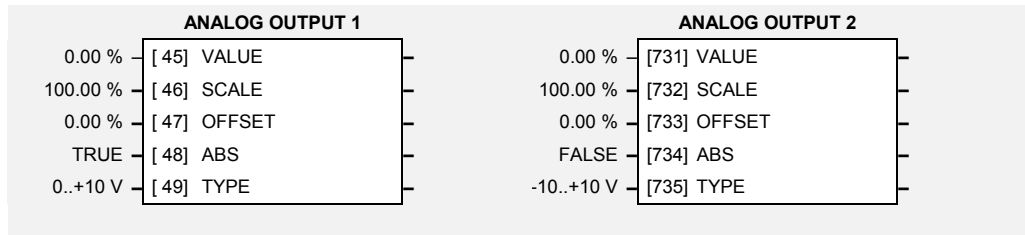

### Parameter Descriptions

#### VALUE

*Range: -300.00 to 300.00 %*

The demanded value to output.

#### SCALE

*Range: -300.00 to 300.00 %*

A scaling factor to apply to VALUE . A scaling factor of 100.00% has no effect.

#### OFFSET

*Range: -300.00 to 300.00 %*

An offset added to VALUE after the scaling factor has been applied. An offset factor of 0.00% has no effect.

#### ABS

*Range: FALSE / TRUE*

When true the output sign is ignored.

#### TYPE

*Range: Enumerated - see below*

The output hardware type, either Volts or Amps.

- ANALOG OUTPUT 1 does not support the -10..+10V type and if this type is selected then the output will be forced to zero.
- ANALOG OUTPUT 2 does not support the current types and if these are selected then the output will be forced to zero.

**Warning:** For correct operation, ensure that the hardware range selected using switch bank SW2 corresponds to the TYPE selected. The values that this parameter may take are:

*Enumerated Value : Type*

- 0 : 0..+10 V
- 1 : 0..20 mA
- 2 : 4..20 mA
- 3 : -10..+10V

See below for how to set the I/O configuration switches.

### Functional Description

The Inverter has two analog outputs. There is an ANALOG OUTPUT function block associated with each of these:

- ANALOG OUTPUT 1 is associated with terminal 6
- ANALOG OUTPUT 2 is associated with terminal 7

The scaling and offset parameters are applied to the demand value as shown.

If ABS is TRUE then the final output is the magnitude of value after being scaled and offset. If ABS is FALSE then the final output will be limited to be within the range selected by TYPE.

# 6-12 Programming Your Application

With scale and offset applied, a value of 0.00 causes the output to be equal to the low hardware range, (i.e. 0V on ANALOG OUTPUT 1 or -10V on ANALOG OUTPUT 2 for the 0 to 10V range ), a value of 100.00% causes the output to be equal to the high hardware range, (i.e. 10V on the 0 to 10V range).

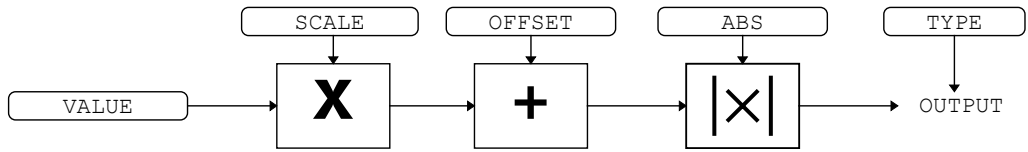

## Configuration Switch Settings (SW2)

The analog output terminals are configured for voltage or current operation by the I/O configuration switch settings. Remember to select the appropriate TYPE parameter.

Input	Type	Switch Settings
ANALOG OUTPUT 1	0-20 or 4-20mA	SW2/1 OFF, SW2/2 OFF
Terminal 6	0-10V*	SW2/1 ON, SW2/2 ON*
* Default settings, as shown		

Table 6-3 Select Input Signal

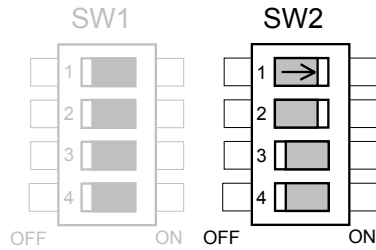

Figure 6-4 I/O Configuration Switches shown at Manufacturing defaults

## MMI Menu Map

- 1 SETUP PARAMETERS
- 2 FUNCTION BLOCKS
- 3 SEQ & REF
- 4 AUTO RESTART
  - AR ENABLE
  - AR ATTEMPTS
  - AR INITIAL DLY 1
  - AR ATTEMPT DLY 1
  - AR TRIGGERS 1
  - AR TRIGGERS+ 1
  - AR INITIAL DLY 2
  - AR ATTEMPT DLY 2
  - AR TRIGGERS 2
  - AR TRIGGERS+ 2
  - AR PENDING
  - AR RESTARTING
  - AR ATTEMPTS LEFT
  - AR TIME LEFT

## AUTO RESTART

Auto Restart (or Auto Reset) provides the facility to automatically reset a choice of trip events and restart the drive with a programmed number of attempts, after which, a manual or remote trip reset is required if the drive is not successfully restarted. The number of attempted restarts are recorded. This count is cleared after a trip-free period of operation (5 minutes or 4 x ATTEMPT DELAY 1, whichever is the longer), or after a successful manual or remote trip reset. This function is inhibited in Remote Sequencing Comms mode.

AUTO RESTART		
	PENDING [608]	FALSE
	RESTARTING [616]	FALSE
	ATTEMPTS LEFT [614]	5
	TIME LEFT [615]	10.0 s
FALSE	[611] ENABLE	
5	[612] ATTEMPTS	
10.0 s	[610] INITIAL DELAY 1	
10.0 s	[613] ATTEMPT DELAY 1	
0000	[609] TRIGGERS 1	
0000	[744] TRIGGERS+ 1	
0.1 s	[678] INITIAL DELAY 2	
0.1 s	[679] ATTEMPT DELAY 2	
0000	[677] TRIGGERS 2	
0000	[745] TRIGGERS+ 2	

## Parameter Descriptions

### ENABLE

Enables operation of the auto restart feature.

Range: FALSE / TRUE

### ATTEMPTS

Determines the number of restarts that will be permitted before requiring an external fault reset.

Range: 1 to 10

### INITIAL DELAY 1

Determines the delay for the first restart attempt when the trip is included in TRIGGERS 1. The delay is measured from all error conditions clearing.

Range: 0.0 to 600.0 s

### ATTEMPT DELAY 1

Determines the delay between restart attempts for a trip included in TRIGGERS 1. The delay is measured from all error conditions clearing.

Range: 0.0 to 600.0 s

### TRIGGERS 1 and TRIGGERS+ 1

Allows Auto Restart to be enabled for a selection of trip conditions.

Range: 0000 to FFFF

Refer to “Hexadecimal Representation of Trips” at the beginning of this chapter for an explanation of the four-digit codes.

### INITIAL DELAY 2

Determines the delay for the first restart attempt when the trip is included in TRIGGERS 2. The delay is measured from all error conditions clearing.

Range: 0.0 to 600.0 s

### ATTEMPT DELAY 2

Determines the delay between restart attempts for a trip included in TRIGGERS 2. The delay is measured from all error conditions clearing.

Range: 0.0 to 600.0 s

### TRIGGERS 2 and TRIGGERS+ 2

Allows Auto Restart to be enabled for a selection of trip conditions.

Range: 0000 to FFFF

If a trip is included in both TRIGGERS 1 and TRIGGERS 2, then the times associated with TRIGGERS 1 will take priority.

Refer to “Hexadecimal Representation of Trips” at the beginning of this chapter for an explanation of the four-digit codes.

## 6-14 Programming Your Application

**PENDING***Range: FALSE / TRUE*

Indicates that an auto restart will occur after the programmed delay.

**RESTARTING***Range: FALSE / TRUE*

Indicates that an auto restart is occurring.

**ATTEMPTS LEFT***Range: xxxxx*

Indicates the number of attempts left before an external fault reset is required.

**TIME LEFT***Range: xxxx.x s*

When in the timing sub-state, this parameter indicates the time left before an auto restart attempt will be permitted. When non-zero, this value is unaffected by changes to ATTEMPT DELAY 1.

## MMI Menu Map

- 1 SETUP PARAMETERS
- 2 FUNCTION BLOCKS
- 3 MOTOR CONTROL
- 4 AUTOTUNE
  - AUTOTUNE ENABLE
  - AUTOTUNE MODE
  - AUTOTUNE ACTIVE

## AUTOTUNE

This is an automated sequence by which the Inverter can identify the motor parameters necessary for correct operation in the Sensorless Vector Fluxing mode.

Refer to Chapter 4: “Operating the Inverter” - Set-up using the Sensorless Vector Fluxing Mode.

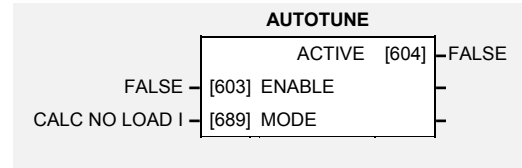

## Parameter Descriptions

### ENABLE

*Range: FALSE / TRUE*

Determines whether the Autotune sequence is operational or not. The Autotune sequence is operational when set to TRUE.

### MODE

*Range: Enumerated - see below*

If set to USER NO LOAD I, the known value (NO LOAD CALIB) is used from the CURRENT FEEDBACK block. If set to CALC NO LOAD I, this block will calculate a value for NO LOAD CALIB and update it in the CURRENT FEEDBACK block.

*Enumerated Value : Mode*

- 0 : USER NO LOAD I
- 1 : CALC NO LOAD I

### ACTIVE

*Range: FALSE / TRUE*

This indicates the current state of the Autotune sequence. The Autotune sequence is operational when displaying TRUE.

## Functional Description

The Autotune sequence takes a maximum of 10 seconds to identify four critical parameters:

1. No-load rms line current
2. Per-phase stator resistance
3. Per-phase leakage inductance
4. Per-phase mutual inductance

The value of 1 above is stored in the CURRENT FEEDBACK block. The values for 2, 3 & 4 are stored in the VECTOR FLUXING block. Autotune will overwrite any previous entry made for these parameters.

Autotune can only be initiated from the “stopped” condition. The function block cannot be changed whilst the drive is running. When the test is complete, the stack is disabled and the motor left to coast.

# 6-16 Programming Your Application

## MMI Menu Map

- 1 SETUP PARAMETERS
- 2 FUNCTION BLOCKS
- 3 SETPOINT FUNCS
- 4 BRAKE CONTROL
  - BRAKE ON LOAD
  - BRAKE ON FREQ
  - BRAKE OFF FREQ
  - BRAKE ON HOLD
  - BRAKE OFF HOLD
  - BRAKE RELEASE
  - BRAKE HOLD

## BRAKE CONTROL

This is used to control electro-mechanical motor brakes in hoist and lift applications.

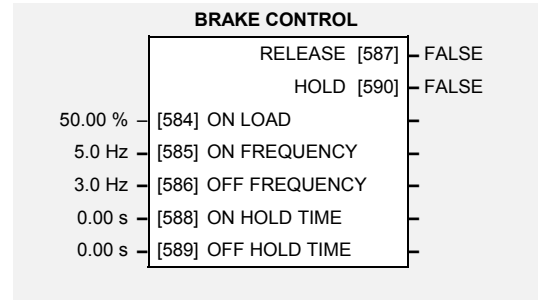

## Parameter Descriptions

### ON LOAD

Load level at which the external motor brake is applied.

Range: 0.00 to 150.00 %

### ON FREQUENCY

Frequency at which the external motor brake is applied.

Range: 0.0 to 480.0 Hz

### OFF FREQUENCY

Frequency at which the external motor brake is released.

Range: 0.0 to 480.0 Hz

### ON HOLD TIME

Sets the duration of the pulse output on HOLD when RELEASE becomes TRUE.

Range: 0.00 to 60.00 s

### OFF HOLD TIME

Sets the duration of the pulse output on HOLD when RELEASE becomes FALSE.

Range: 0.00 to 60.00 s

### RELEASE

Boolean output providing a signal to operate the brake delay

Range: FALSE / TRUE

### HOLD

Becomes TRUE when the brake is toggled On or Off by the function block, and remains TRUE for the duration set by OFF HOLD TIME or ON HOLD TIME.

Range: FALSE / TRUE

## Functional Description

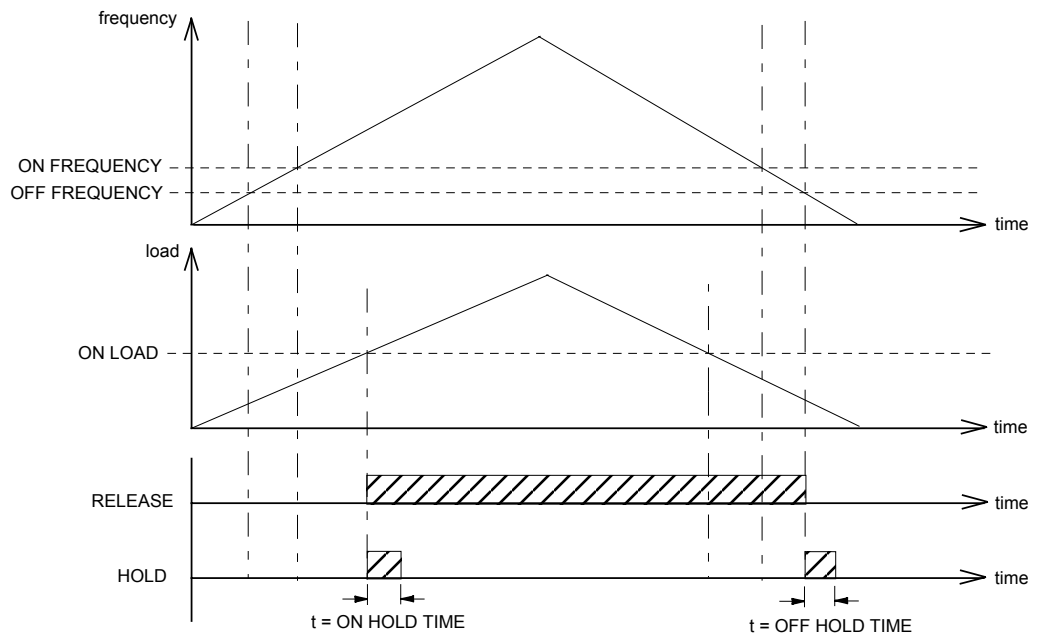

## MMI Menu Map

1	SETUP PARAMETERS
2	FUNCTION BLOCKS
3	SERIAL LINKS
4	COMMS CONTROL
	REMOTE COMMS SEL
	REMOTE SEQ MODES
	REMOTE REF MODES
	COMMS TIMEOUT
	COMMS STATUS
	COMMS COMMAND
	COMMS SEQ
	COMMS REF

## COMMS CONTROL

This block switches between Remote Terminal and Remote Comms operating modes.

The Inverter must be in Remote mode for selection to be made - REMOTE mode is enabled in the LOCAL CONTROL function block and selected by the Operator Station. Refer to the outputs of the LOCAL CONTROL function block for the mode in use.

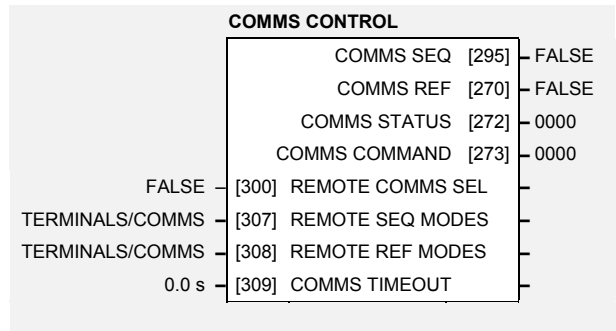

## Parameter Descriptions

### REMOTE COMMS SEL

Range: FALSE / TRUE

Selects the type of remote communications mode:

0 : FALSE, and in REMOTE mode then control is from the terminals.

1 : TRUE, and in REMOTE mode then control is from the communications.

### REMOTE SEQ MODES

Range: Enumerated - see below

Selects the type of remote sequencing mode:

Enumerated Value : Mode

0 : TERMINALS/COMMS

1 : TERMINALS ONLY

2 : COMMS ONLY

### REMOTE REF MODES

Range: Enumerated - see below

Selects the type of remote reference mode:

Enumerated Value : Mode

0 : TERMINALS/COMMS

1 : TERMINALS ONLY

2 : COMMS ONLY

### COMMS TIMEOUT

Range: 0.0 to 600.0 s

Sets the maximum time allowed between refreshing the COMMS COMMAND parameter. The drive will trip if this time is exceeded. Set the time to 0.00 secs to disable this feature.

### COMMS STATUS

Range: 0000 to FFFF

Diagnostic showing the 16-bit Status word as seen by the communications.

Refer to Chapter 9: "Sequencing Logic".

### COMMS COMMAND

Range: 0000 to FFFF

Diagnostic showing the 16-bit Command as written by the communications.

Refer to Chapter 9: "Sequencing Logic".

### COMMS SEQ

Range: FALSE / TRUE

Diagnostic indicating if operating in Remote Sequencing Comms Mode

### COMMS REF

Range: FALSE / TRUE

Diagnostic indicating if operating in Remote Reference Comms Mode.

If FALSE (0), the Inverter may be in Local Reference mode or Remote Reference Terminal mode.

## MMI Menu Map

- 1 SETUP PARAMETERS
- 2 FUNCTION BLOCKS
- 3 MOTOR CONTROL
- 4 CURRENT FEEDBACK
  - FULL LOAD CALIB
  - NO LOAD CALIB
  - POWER FACTOR
  - QUADRATIC TORQUE
  - MOTOR CURRENT
  - MOTOR CURRENT
  - I MAGNETISING
  - I MAGNETISING
  - I TORQUE
  - I TORQUE
  - LOAD
  - FIELD

## CURRENT FEEDBACK

This function block allows the user to match the Inverter's current rating to the motor under control. The Inverter needs to be programmed with the motor full-load and no-load (magnetising) rms line current values.

From this information, magnetising (flux producing) and torque producing motor current diagnostics can be generated.

CURRENT FEEDBACK		
MOTOR CURRENT	[ 66]	-0.00 %
MOTOR CURRENT	[ 67]	-0.0 A
I MAGNETISING	[ 68]	-0.00 %
I MAGNETISING	[ 69]	-0.0 A
I TORQUE	[ 70]	-0.00 %
I TORQUE	[ 71]	-0.0 A
LOAD	[ 72]	-0.00 %
FIELD	[ 73]	-0.00 %
**2.0 A	[ 64]	FULL LOAD CALIB
**1.4 A	[ 65]	NO LOAD CALIB
** 0.70	[242]	POWER FACTOR
FALSE	[ 50]	QUADRATIC TORQUE

## Parameter Descriptions

### FULL LOAD CALIB

*Range: 0.0 to 1000.0 A*

Set this to the motor nameplate full-load rms line current. The parameter is internally clamped within the range of 25% to 100% of the Inverter current rating.

### NO LOAD CALIB

*Range: 0.0 to 1000.0 A*

Set this to the motor no-load rms line current. This is normally between 30% to 40% of the motor nameplate full-load rms line current. However for small motors this proportion can be much higher. If in doubt, this information can be obtained from the motor manufacturer. Alternatively, the parameter should be set to rms line current drawn from the Inverter when running the motor under no-load at base frequency.

The value of NO LOAD CALIB is internally clamped in the Inverter to be within 10% to 90% of the FULL LOAD CALIB setting.

### POWER FACTOR

*Range: 0.50 to 0.95*

Set this to the motor power factor rating given on the nameplate.

### QUADRATIC TORQUE

*Range: FALSE / TRUE*

When TRUE, selects higher continuous rating with less overload capability. Quadratic Torque operation is especially suited to fan or pump applications.

**Note:** Sensorless Vector operation is automatically disabled when using the Inverter in Quadratic Torque mode. Refer to Quadratic Torque Selection, page 6-84.

### MOTOR CURRENT

*Range: xxx.xh % (h)*

This diagnostic contains the level of rms line current being drawn from the Inverter and is seen as a % of the FULL LOAD CALIB setting.

### MOTOR CURRENT

*Range: xxx.x A*

This diagnostic contains the level of rms line current being drawn from the Inverter.

### I MAGNETISING

*Range: xxx.xh % (h)*

This diagnostic contains the level of magnetising (flux producing) rms line current component being drawn from the Inverter and is seen as a % of the FULL LOAD CALIB setting.

### I MAGNETISING

*Range: xxx.x A*

This diagnostic contains the level of magnetising (flux producing) rms line current component being drawn from the Inverter.

## I TORQUE

*Range: xxx.xh % (h)*

This diagnostic contains the level of torque producing rms line current component being drawn from the Inverter and is seen as a % of the FULL LOAD CALIB setting.

## I TORQUE

*Range:xxxx.x A*

This diagnostic contains the level of torque producing rms line current component being drawn from the Inverter.

## LOAD

*Range: xxx.xh % (h)*

This diagnostic is a normalised version of the I TORQUE diagnostic. A value of 100% indicates the motor is operating at rated load (torque).

## FIELD

*Range: xxx.xh % (h)*

This diagnostic is a normalised version of the I MAGNETISING diagnostic. A value of 100% indicates the motor is operating at rated magnetic flux (field).

## Functional Description

The current feedback function block processes motor line current measurements and provides diagnostics of line current magnitude, torque producing current and magnetic field producing current components. The line current magnitude (the motor current measured using a current meter) can be considered to be the vector sum of the field and torque producing current components.

The function block requires appropriate values for full-load and no-load motor currents to be entered. Once done, the function block will provide measurements of:-

rms line current:

**I MAGNITUDE (MOTOR CURRENT)**

rms field current component:

**I MAGNETISING**

torque current component:

**I TORQUE.**

These diagnostics are presented in Amps, and as a percentage of the user set motor full-load current.

In addition, the field current component is re-scaled to provide a FIELD diagnostic. A value of 100.0% in the field diagnostic indicates that the motor is operating at rated flux. The torque current component is re-scaled to provide a LOAD diagnostic. A value of 100.0% in the load diagnostic indicates that the motor is operating at rated torque or full load.

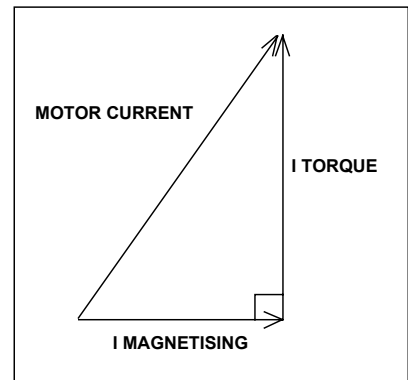

# 6-20 Programming Your Application

## MMI Menu Map

- 1 SETUP PARAMETERS
- 2 FUNCTION BLOCKS
- 3 MOTOR CONTROL
- 4 CURRENT LIMIT
  - MOTOR I LIMIT
  - REGEN I LIMIT
  - FEEDBACK SOURCE
  - REGEN LIM ENABLE
  - CURRENT LIMITING

## CURRENT LIMIT

This function block allows the user to set the maximum level of line current or motor load at which the Inverter is intended to operate. If the measured level of current or load exceeds the MOTOR I LIMIT value, the Inverter attempts to shed motoring current or load by reducing its output frequency (reduce motor speed). Under extreme conditions, the Inverter frequency can be reduced to zero.

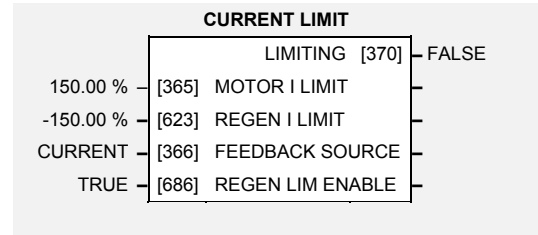

If the measured level of current or load exceeds the REGEN I LIMIT, the Inverter attempts to shed regenerating current or load by increasing its output frequency. Under extreme conditions, the Inverter frequency can be increased up to the maximum speed setting. You can disable the action of REGEN I LIMIT.

## Parameter Descriptions

### MOTOR I LIMIT

*Range: 0.00 to 150.00 %*

This parameter sets the level of motor current, as a % of FULL LOAD CALIB (refer to the CURRENT FEEDBACK function block) at which the Inverter begins to reduce the Inverter output frequency.

### REGEN I LIMIT

*Range: -150.00 to 0.00 %*

This parameter sets the level of motor current, as a % of FULL LOAD CALIB (refer to the CURRENT FEEDBACK function block) at which the Inverter begins to increase the Inverter output frequency.

### FEEDBACK SOURCE

*Range: Enumerated - see below*

This parameter determines the feedback source (measured value) for the current limit. The feedback source determines the mode of current limit operation.

*Enumerated Value : Feedback Source*

- 0 : CURRENT
- 1 : LOAD

### REGEN LIM ENABLE

*Range: FALSE / TRUE*

This parameter enables or disables REGEN I LIMIT.

### LIMITING

*Range: FALSE / TRUE*

This diagnostic indicates whether the current limit is active (altering Inverter output frequency) or inactive.

## CUSTOM SCREEN

This function block provides a custom screen for displaying any parameter. It allows you to enter any 16 character name for the parameter and to display and enter in a convenient and recognisable form.

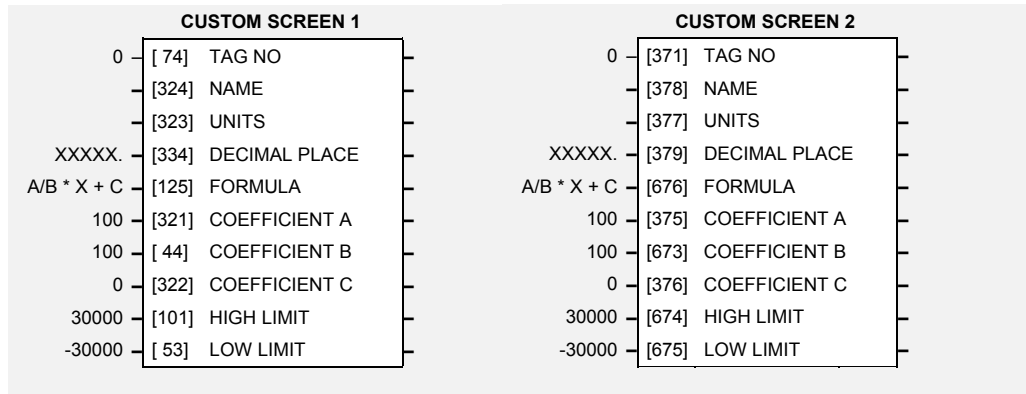
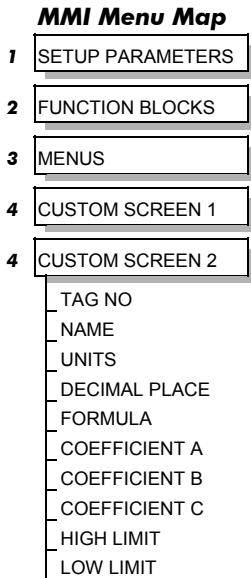

## Parameter Descriptions

### TAG NO

*Range: 0 to 787*

Enter the tag number of the parameter to be displayed

### NAME

*Range: 16 characters*

A 16 character label that is displayed as the parameter name.

### UNITS

*Range: 5 characters*

A 5 character label that is displayed as the parameter units.

### DECIMAL PLACE

*Range: Enumerated - see below*

Select the position of the decimal point. Note that “\_” indicates a character that will not display on the Operator Station.

*Enumerated Value : Decimal Place*

- 0 : XXXXX.
- 1 : XXXX.X
- 2 : XXX.XX
- 3 : XX.XXX
- 4 : X.XXXX
- 5 : XXXX.\_
- 6 : XXX.X\_
- 7 : XX.XX\_
- 8 : X.XXX\_

### FORMULA

*Range: Enumerated - see below*

*Enumerated Value : Formula*

- 0 : A/B \* X + C
- 1 : A/B \* (X+C)
- 2 : A/(B \* X) + C
- 3 : A/(B \* (X+C))

# 6-22 Programming Your Application

## COEFFICIENT A

Range: -30000 to 30000

Coefficient used as defined by the formula.

## COEFFICIENT B

Range: 1 to 30000

Coefficient used as defined by the formula.

## COEFFICIENT C

Range: -30000 to 30000

Coefficient used as defined by the formula.

## HIGH LIMIT

Range: -30000 to 30000

Use high limit to set a maximum value on the Operator Station. Setting the HIGH LIMIT lower than or equal to the LOW LIMIT makes the parameter “read-only”.

## LOW LIMIT

Range: -30000 to 30000

Use low limit to set a minimum value on the Operator Station. Setting the HIGH LIMIT higher than or equal to the HIGH LIMIT makes the parameter “read-only”.

## Functional Description

The custom screen feature may be used to customise the display of any parameter within the Inverter.

For display purposes, the parameter is modified according to the formula chosen. For editing purposes, the inverse formula is applied to the displayed value to calculate the value to be used.

The coefficients, formulae and units are not applied to enumerated parameters.

Refer to the OPERATOR MENU function block description for details of how to display the custom screens on the Operator menu.

## Character Sets

The table below lists the characters supported by the software in decimal and hexadecimal.

	HEX	DEC		HEX	DEC		HEX	DEC		HEX	DEC		HEX	DEC		HEX	DEC
	20	32	0	30	48	@	40	64	P	50	80	,	60	96	p	70	112
!	21	33	1	31	49	A	41	65	Q	51	81	a	61	97	q	71	113
"	22	34	2	32	50	B	42	66	R	52	82	b	62	98	r	72	114
#	23	35	3	33	51	C	43	67	S	53	83	c	63	99	s	73	115
\$	24	36	4	34	52	D	44	68	T	54	84	d	64	100	t	74	116
%	25	37	5	35	53	E	45	69	U	55	85	e	65	101	u	75	117
&	26	38	6	36	54	F	46	70	V	56	86	f	66	102	v	76	118
'	27	39	7	37	55	G	47	71	W	57	87	g	67	103	w	77	119
(	28	40	8	38	56	H	48	72	X	58	88	h	68	104	x	78	120
)	29	41	9	39	57	I	49	73	Y	59	89	i	69	105	y	79	121
*	2A	42	:	3A	58	J	4A	74	Z	5A	90	j	6A	106	z	7A	122
+	2B	43	;	3B	59	K	4B	75	[	5B	91	k	6B	107	{	7B	123
,	2C	44	<	3C	60	L	4C	76	■	5C	92	l	6C	108		7C	124
-	2D	45	=	3D	61	M	4D	77	]	5D	93	m	6D	109	}	7D	125
.	2E	46	>	3E	62	N	4E	78	^	5E	94	n	6E	110			
/	2F	47	?	3F	63	O	4F	79	_	5F	95	o	6F	111			

## MMI Menu Map

- 1 SETUP PARAMETERS
- 2 FUNCTION BLOCKS
- 3 MISCELLANEOUS
- 4 DEMULTIPLEXER
  - INPUT
  - OUTPUT 0
  - OUTPUT 1
  - OUTPUT 2
  - OUTPUT 3
  - OUTPUT 4
  - OUTPUT 5
  - OUTPUT 6
  - OUTPUT 7
  - OUTPUT 8
  - OUTPUT 9
  - OUTPUT 10
  - OUTPUT 11
  - OUTPUT 12
  - OUTPUT 13
  - OUTPUT 14
  - OUTPUT 15

## DEMULTIPLEXER

The demultiplexer function block splits the input word into 16 individual bits.

This may be used to extract the individual trip bits from the ACTIVE TRIPS parameter, for example.

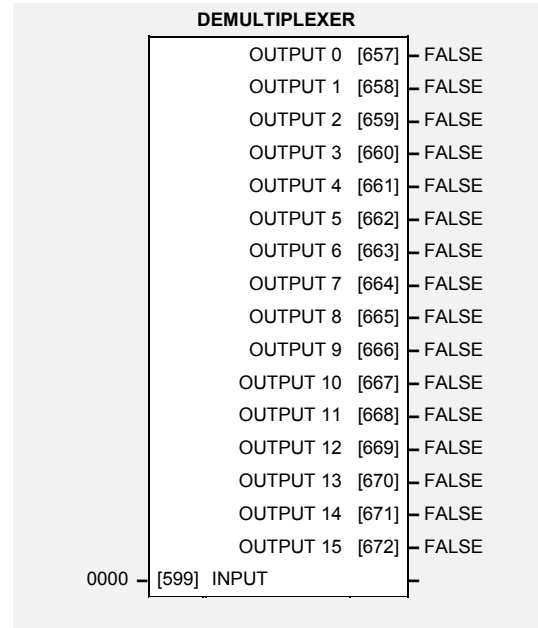

## Parameter Descriptions

### INPUT

The input to be split into its component bits.

*Range: 0000 to FFFF*

### OUTPUT 0 TO OUTPUT 15

Each output returns the corresponding bit of the 16 bit input word.

*Range: FALSE / TRUE*

## DIGITAL INPUT

The digital input block converts the physical input voltage to TRUE or FALSE control signals.

**MMI Menu Map**

- 1 SETUP PARAMETERS
- 2 FUNCTION BLOCKS
- 3 INPUTS & OUTPUTS
- 4 DIGITAL INPUT
- 5 DIGITAL INPUT 1
- 5 DIGITAL INPUT 2
- 5 DIGITAL INPUT 3
- 5 DIGITAL INPUT 4
- 5 DIGITAL INPUT 5
- 5 DIGITAL INPUT 6
- 5 DIGITAL INPUT 7
- 5 DIGITAL INPUT 8
  - DIN 8 INVERT
  - DIN 8 VALUE

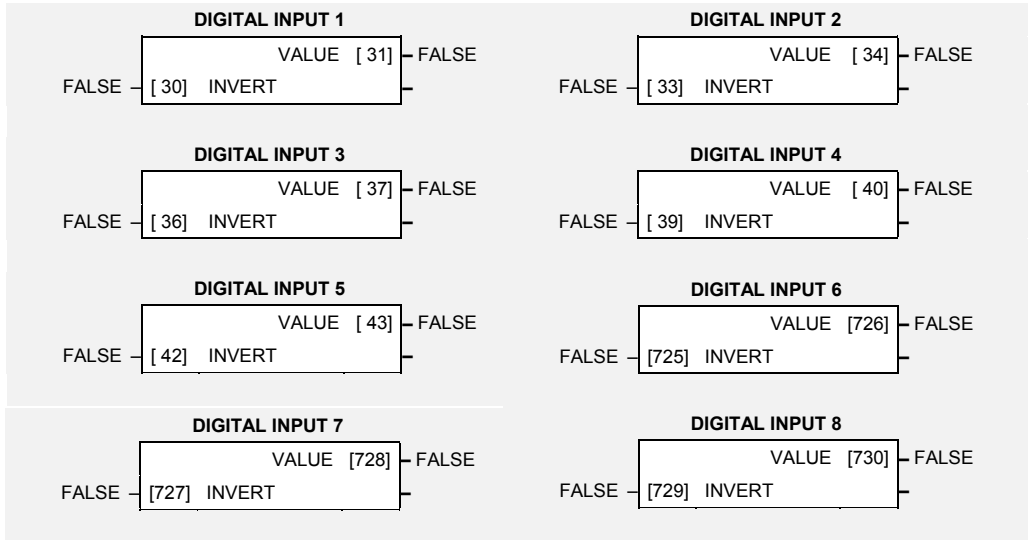

### Parameter Descriptions

**INVERT**

Controls the optional inversion of the VALUE output.

*Range: FALSE / TRUE*

**VALUE**

The TRUE or FALSE input, (after any inversion).

*Range: FALSE / TRUE*

### Functional Description

The Inverter has eight digital inputs. There is a DIGITAL INPUT function block associated with each of these:

- DIGITAL INPUT 1 is associated with terminal 13
- DIGITAL INPUT 2 is associated with terminal 14
- DIGITAL INPUT 3 is associated with terminal 15
- DIGITAL INPUT 4 is associated with terminal 16
- DIGITAL INPUT 5 is associated with terminal 17
- DIGITAL INPUT 6 is associated with terminal 18
- DIGITAL INPUT 7 is associated with terminal 19
- DIGITAL INPUT 8 is associated with terminal 20

The input electronics of the Inverter converts the input signal to a TRUE or FALSE logic value. The digital input block takes this value and optionally inverts it before providing the VALUE output.

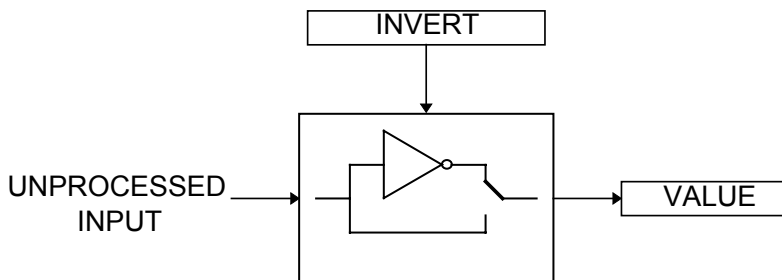

## MMI Menu Map

- 1 SETUP PARAMETERS
- 2 FUNCTION BLOCKS
- 3 INPUTS & OUTPUTS
- 4 DIGITAL OUTPUT
- 5 DIGITAL OUTPUT 1
- 5 DIGITAL OUTPUT 2
- 5 DIGITAL OUTPUT 3
  - DOUT 3 VALUE
  - DOUT 3 INVERT

## DIGITAL OUTPUT

The digital output block converts a logic TRUE or FALSE demand to a physical output signal.

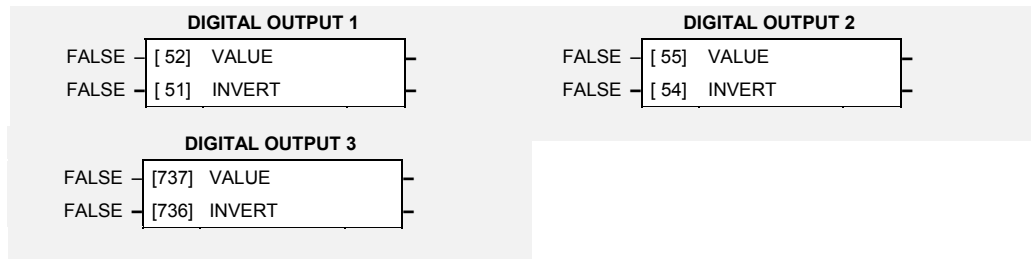

## Parameter Descriptions

### VALUE

The TRUE or FALSE output demand.

Range: FALSE / TRUE

### INVERT

Controls the optional inversion of the VALUE output.

Range: FALSE / TRUE

## Functional Description

The Inverter has three physical digital outputs (volt-free relay contacts). There is a DIGITAL OUTPUT function block associated with each of these:

DIGITAL OUTPUT 1 is associated with terminals 21 & 22

DIGITAL OUTPUT 2 is associated with terminals 23 & 24

DIGITAL OUTPUT 3 is associated with terminals 25 & 26

INVERT reverses the output logic.

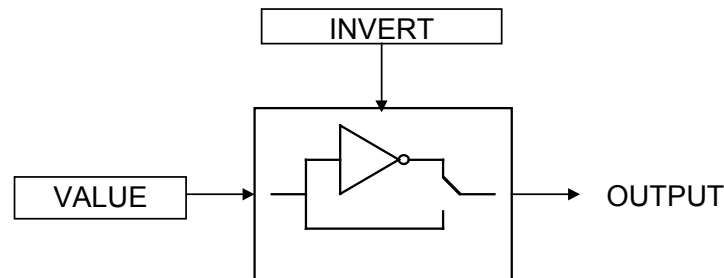

# 6-26 Programming Your Application

## MMI Menu Map

- 1 SETUP PARAMETERS
- 2 FUNCTION BLOCKS
- 3 MOTOR CONTROL
- 4 DYNAMIC BRAKING
  - BRAKE ENABLE
  - BRAKE RESISTANCE
  - BRAKE POWER
  - BRAKE 1S RATING
  - DC LINK VOLTS
  - BRAKING

## DYNAMIC BRAKING

The dynamic braking function block controls the rate at which energy from a regenerating motor is dumped into a resistive load. This dumping prevents the internal voltage in the Inverter from reaching levels which could damage the Inverter electronics.

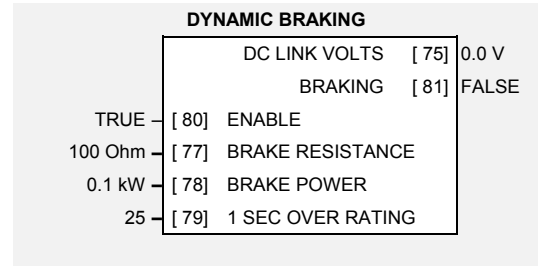

## Parameter Descriptions

### ENABLE

Enables operation of the dynamic braking block.

Range: FALSE / TRUE

### BRAKE RESISTANCE

The value of the load resistance.

Range: 1 to 1000 Ohm

### BRAKE POWER

The power that the load resistance may continually dissipate.

Range: 0.1 to 510.0 kW

### 1 SEC OVER RATING

The power that the load resistance may dissipate for 1 second.

Range: 1 to 40

### DC LINK VOLTS

The internal dc voltage tested by the braking block.

Range: xxxx.x V

### BRAKING

A read-only parameter indicating the state of the brake switch.

Range: FALSE / TRUE

## Functional Description

When enabled, the Dynamic Braking block monitors the internal dc link voltage every millisecond and sets the state of the brake switch accordingly.

The dynamic braking block provides a control signal that is operated on by the slew rate limits block. This causes the setpoint to be temporarily frozen whenever the dc link voltage exceeds the internal comparison level. This allows the stop rate to be automatically tuned to the characteristics of the load, motor, Inverter and brake resistor.

The dynamic braking block operates even when the motor output is not enabled. This allows the block to continually monitor the energy dumped into the braking resistor, and the energy dissipated across the brake switch. With this information the Inverter is able to deduce the loading on the brake resistor. An optional trip may be enabled should the resistor be loaded beyond its capabilities.

Refer also to Chapter 13: “Application Notes” - Dynamic Braking.

## MMI Menu Map

- 1 SETUP/DIAGNOSTIC
- 2 FUNCTION BLOCKS
- 3 INPUTS & OUTPUTS
- 4 ENCODER
  - ENCODER MODE
  - ENCODER RESET
  - ENCODER LINES
  - ENCODER INVERT
  - ENCODER SUPPLY
  - ENCODER SPEED
  - ENCODER SPEED
  - ENCODER SPEED
  - ENCODER POSITION

## ENCODER

The ENCODER block allows Speed Feedback to be measured when the 6054 Speed Feedback Technology Option is fitted. Simple position measuring is also provided, but is limited to a 16-bit range.

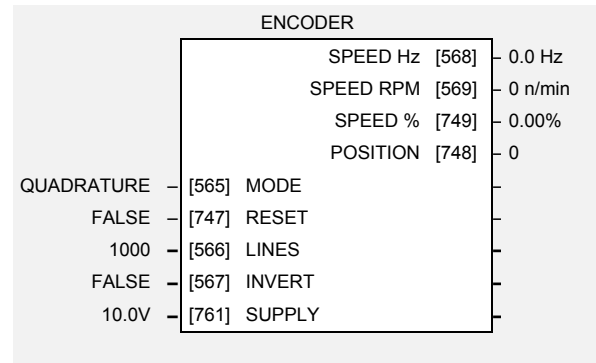

## Parameter Descriptions

### MODE

*Range: Enumerated - see below*

This must be set to QUADRATURE or CLOCK. The CLOCK/DIRECTION option is not supported on this product.

*Enumerated Value : Mode*

- 0 : QUADRATURE
- 1 : CLOCK/DIR
- 2 : CLOCK

### RESET

*Range: FALSE / TRUE*

When TRUE the POSITION output is set (and held) at zero.

### LINES

*Range: 1 to 10000*

The number of lines must be set to match the type of encoder being used. Incorrect setting of this parameter will result in an erroneous speed measurement.

### INVERT

*Range: FALSE / TRUE*

When TRUE, changes the sign of the measured speed and the direction of the position count.

### SUPPLY

*Range: 10.0 to 20.0V*

Encoder supply voltage.

### SPEED Hz

*Range: xxx.x Hz*

Speed feedback in Hz.

### SPEED RPM

*Range: xxxxx n/min*

Speed feedback in RPM.

### SPEED %

*Range: xxx.xx %*

Speed feedback as a percentage of MAXIMUM SPEED.

### POSITION

*Range: xxxxx*

Number of encoder "counts" from when RESET was set to FALSE. The value will increment or decrement depending on the direction the encoder is rotated. The value will "wrap around" between 32767 and -32768.

## MMI Menu Map

1	SETUP PARAMETERS
2	FUNCTION BLOCKS
3	MOTOR CONTROL
4	FLUXING
	V/F SHAPE
	V/F SCALE
	BASE FREQUENCY
	LIMIT FREQUENCY
	FIXED BOOST
	AUTO BOOST

## FLUXING

This function block allows user parameterisation of the conventional (volts/hertz) fluxing strategy of the Inverter. This is achieved through two flexible volts to frequency templates. Starting torque performance can also be tailored through the FIXED BOOST and AUTO BOOST parameters.

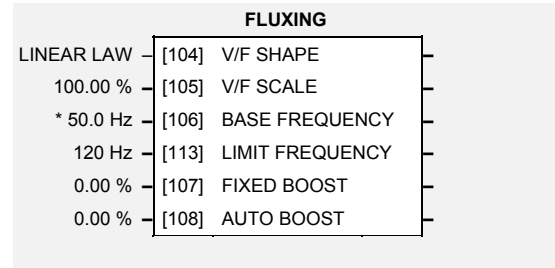

## Parameter Descriptions

### V/F SHAPE

Range: Enumerated - see below

This parameter determines the type of volts to frequency template is used to flux the motor. The choices of this parameter are:

Enumerated Value : V/F Shape

- 0 : LINEAR LAW
- 1 : FAN LAW

### V/F SCALE

Range: 0.00 to 100.00 %

This parameter directly scales the voltage output of the volts to frequency template. This scaling takes place before any boost or auto boost is added.

### BASE FREQUENCY

Range: 7.5 to 480.0 Hz

This parameter determines the frequency at which maximum output volts is generated. Below base frequency, the volts will vary with frequency as determined by the V/F SHAPE parameter. Above base frequency, the volts will saturate at the maximum value.

Setting the BASE FREQUENCY parameter to a value greater than LIMIT FREQUENCY parameter, results in the internal value of base frequency used for the volts to frequency template being clamped at the set value of limit frequency.

### LIMIT FREQUENCY

Range: Enumerated - see below

Sets the value of the maximum output frequency the Inverter is able to supply to the motor. The choices of this parameter are:

Enumerated Value : Limit Frequency

- 0 : 120 Hz
- 1 : 240 Hz
- 2 : 480 Hz

### FIXED BOOST

Range: 0.00 to 25.00 %

This parameter allows for no-load stator resistance voltage drop compensation. This correctly fluxes the motor (under no-load conditions) at low output frequencies, thereby increasing available motor torque. Fixed boost can be set in addition to auto boost.

### AUTO BOOST

Range: 0.00 to 25.00 %

This parameter allows for load dependent stator resistance voltage drop compensation. This correctly fluxes the motor (under load conditions) at low output frequencies, thereby increasing available motor torque. Auto boost can be set in addition to fixed boost.

The value of the AUTO BOOST parameter determines level of additional volts supplied to the motor for 100% load.

Setting the value of auto boost too high can cause the Inverter to enter current limit. If this occurs, the Inverter will be unable to ramp up in speed. Reducing the value of auto boost will eliminate this problem.

## Functional Description

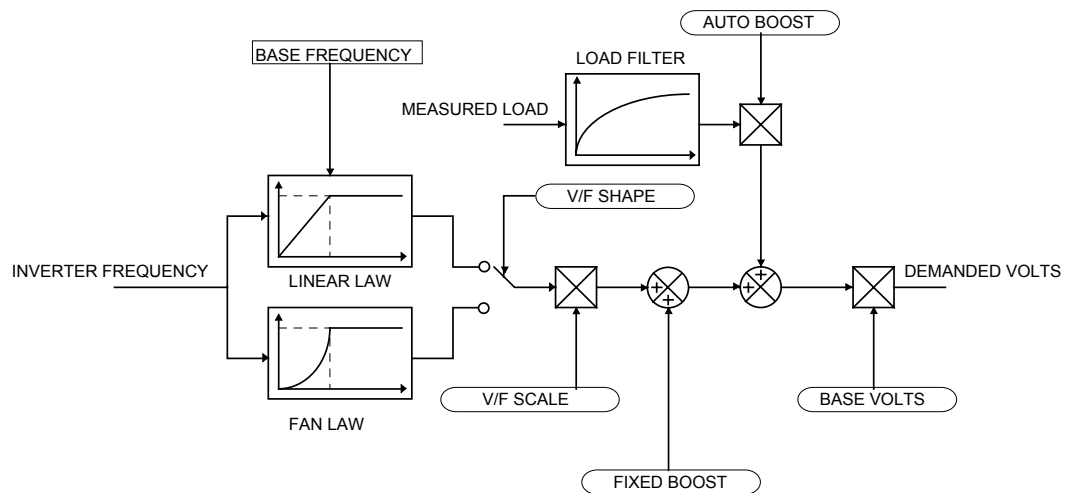

The function block allows the user to parameterise the Inverter's conventional V/F motor fluxing scheme. Two V/F shapes are available, LINEAR LAW and FAN LAW:

- Linear Law V/F shape should be used in applications requiring constant motor torque though out the speed range (e.g. machine tools or hoists).
- Fan Law V/F shape provides extra energy savings for fan or pump applications.

For either of these V/F shapes the BASE FREQUENCY, which is the value of Inverter output frequency at which maximum output volts is provided, can be set by the user.

Correct no-load motor fluxing at low Inverter output frequencies can be achieved by setting the FIXED BOOST parameter.

Correct motor fluxing under load conditions is achieved by setting the AUTO BOOST parameter.

The motor is correctly fluxed when the FIELD diagnostic in the CURRENT FEEDBACK function block reads 100.0% .

## FLYCATCHING

**MMI Menu Map**

- 1 SETUP PARAMETERS
- 2 FUNCTION BLOCKS
- 3 MOTOR CONTROL
- 4 FLY CATCHING
  - FLY CATCH ENABLE
  - FLY START MODE
  - FLY SEARCH MODE
  - FLY SEARCH VOLTS
  - FLY SEARCH BOOST
  - FLY SEARCH TIME
  - FLY MIN SPEED
  - FLY REFLUX TIME
  - FLY CATCH ACTIVE
  - FLY SETPOINT

This block performs a directional speed search. It allows the Inverter to seamlessly catch a spinning motor before controlling the motor to the desired setpoint.

This is especially useful for large inertia fan loads, where drafts in building air ducts can cause a fan to 'windmill'.

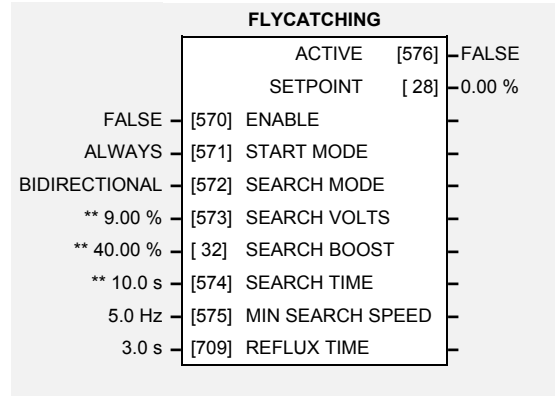

### Parameter Descriptions

#### ENABLE

Enables flycatching when TRUE.

Range: FALSE / TRUE

#### START MODE

The mode of operation for the flycatching sequence software.

Range: Enumerated - see below

Enumerated Value : Start Mode

- 0 : ALWAYS
- 1 : TRIP OR POWERUP
- 2 : TRIP

#### SEARCH MODE

The type of speed search carried out by the flycatching sequence.

Range: Enumerated - see below

Enumerated Value : Search Mode

- 0 : BIDIRECTIONAL
- 1 : UNIDIRECTIONAL

#### SEARCH VOLTS

The percentage level of the search volts applied to the motor during the speed search phase of the flycatching sequence. Increasing this parameter improves the accuracy of the discovered motor speed but increases the braking influence of the speed search on the rotating motor.

Range: 0.00 to 100.00 %

#### SEARCH BOOST

The level of search boost applied to the motor during the speed search phase of the flycatching sequence.

Range: 0.00 to 100.00 %

#### SEARCH TIME

The search rate during the speed search phase of the flycatching sequence. Performing the flycatching speed search too quickly can cause the drive to inaccurately identify the motor speed. Refluxing at an inaccurate motor speed can cause the drive to trip on overvoltage. If this occurs, increasing this parameter will reduce the risk of tripping.

Range: 0.1 to 60.0 s

#### MIN SEARCH SPEED

The lowest search speed before the speed search phase of the flycatching sequence is considered to have failed.

Range: 5.0 to 480.0 Hz

#### REFLUX TIME

The rate of rise of volts from the search level to the working level after a successful speed search. Refluxing the motor too quickly can cause the drive to trip on either overvoltage or overcurrent. In either case, increasing this parameter will reduce the risk of tripping.

Range: 0.1 to 20.0 s

**ACTIVE***Range: FALSE / TRUE*

A diagnostic output indicating whether the flycatching sequence is active.

**SETPOINT***Range xxx.xx %*

This diagnostic output is the setpoint caught at the end of a successful flycatching sequence.

**Functional Description**

The flycatching function enables the drive to be restarted smoothly into a spinning motor. It applies small search voltages to the motor whilst ramping the Inverter frequency from maximum speed to zero. When the motor load goes from motoring to regenerating, the speed search has succeeded and is terminated. If the search frequency falls below the minimum search speed, the speed search has failed and the Inverter will ramp to the speed setpoint from zero.

The flycatching sequence can be triggered by different starting conditions:

ALWAYS: All starts (after controlled or uncontrolled stop, or after a power-up)  
TRIP or POWER-UP: After uncontrolled stop, i.e. trip or coast, or after a power-up  
TRIP: After uncontrolled stop, i.e. trip or coast

The type of speed sequence may be Bidirectional or Unidirectional:

**Bidirectional**

Initially, the search is performed in the direction of the speed setpoint. If the drive fails to identify the motor speed in this direction, a second speed search is performed in the reverse direction.

**Unidirectional**

The search is performed only in the direction of the speed setpoint.

## MMI Menu Map

- 1 SETUP PARAMETERS
- 2 FUNCTION BLOCKS
- 3 MOTOR CONTROL
- 4 INJ BRAKING
  - INJ DEFLUX TIME
  - INJ FREQUENCY
  - INJ I-LIM LEVEL
  - INJ DC PULSE
  - INJ FINAL DC
  - INJ DC LEVEL
  - INJ TIMEOUT
  - INJ BASE VOLTS
  - INJ ACTIVE

## INJ BRAKING

The injection braking block provides a method of stopping spinning induction motors without returning the kinetic energy of the motor and load back in to the dc link of the Inverter. This is achieved by running the motor highly inefficiently so that all the energy stored in the load is dissipated in the motor. Thus, high inertia loads can be stopped without the need for an external dynamic braking resistor.

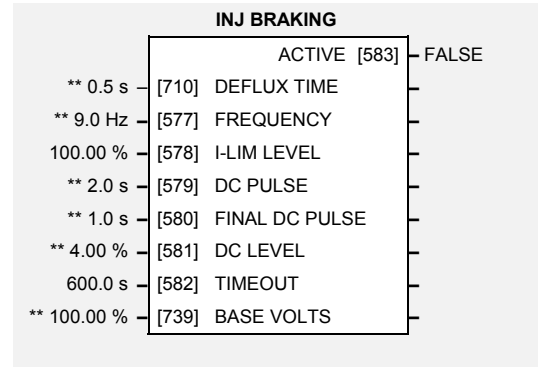

## Parameter Descriptions

### DEFLUX TIME

*Range: 0.1 to 20.0 s*

Determines the time in which the Inverter defluxes the motor prior injection braking.

### FREQUENCY

*Range: 1.0 to 480.0 Hz*

Determines the maximum frequency applied to the motor for the low frequency injection braking mode. It is also clamped internally so as never to exceed 50% of base speed value.

### I-LIM LEVEL

*Range: 50.00 to 150.00 %*

Determines the level of motor current flowing during low frequency injection braking.

### DC PULSE

*Range: 0.0 to 100.0 s*

Determines the duration of the dc pulse applied to the motor when injection braking is required for motor speeds below 20% of base speed. The actual dc pulse time applied to the motor is dependent on the ratio of initial motor speed to 20% of base speed.

### FINAL DC PULSE

*Range: 0.0 to 10.0 s*

Determines the duration of the final dc holding pulse applied to the motor after either low frequency injection braking or timed dc pulse.

### DC LEVEL

*Range: 0.00 to 25.00 %*

Determines the level of dc pulse applied to the motor during either the timed or final dc pulse.

### TIMEOUT

*Range: 0.0 to 600.0 s*

Determines the maximum amount of time the sequence is allowed to remain in the low frequency injection braking state.

### BASE VOLTS

*Range: 0.00 to 115.47 %*

Determines the maximum volts at base speed applied to the motor during injection braking.

### ACTIVE

*Range: FALSE / TRUE*

Indicates the state of the Inverter. TRUE when injection braking.

**MMI Menu Map**

- 1 SETUP PARAMETERS
- 2 FUNCTION BLOCKS
- 3 TRIPS
- 4 I/O TRIPS
  - EXTERNAL TRIP
  - INPUT 1 BREAK
  - INPUT 2 BREAK

## I/O TRIPS

This function block is designed to operate in conjunction with the Analog and Digital Input function blocks to trip the Inverter on a loss of setpoint input or safety control input.

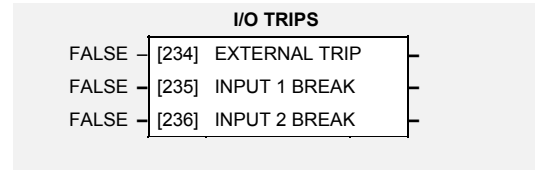

## Parameter Descriptions

### EXTERNAL TRIP

*Range: FALSE / TRUE*

A general purpose signal designed to be internally wired to a digital input block. When this signal goes TRUE this causes an EXTERNAL TRIP to occur, (unless this trip is disabled within the TRIPS area).

This parameter is not saved in the Inverter's non-volatile memory and thus is reset to the default setting at power-up.

### INPUT 1 BREAK

*Range: FALSE / TRUE*

A general purpose signal designed to be internally wired to the function block ANALOG INPUT 1, BREAK parameter. When this signal goes TRUE this causes an INPUT 1 BREAK trip to occur, (unless this trip is disabled within the TRIPS STATUS function block, see DISABLED TRIPS).

This parameter is not saved in the Inverter's non-volatile memory and thus is reset to the default setting at power-up.

### INPUT 2 BREAK

*Range: FALSE / TRUE*

A general purpose signal designed to be internally wired to the function block ANALOG INPUT 2, BREAK parameter. When this signal goes TRUE this causes an INPUT 2 BREAK trip to occur (unless this trip is disabled within the TRIPS STATUS function block, see DISABLED TRIPS).

This parameter is not saved in the Inverter's non-volatile memory and thus is reset to the default setting at power-up.

## Functional Description

The I/O TRIPS function block allows trips to be generated by signals on the input terminals of the Inverter. Refer to Chapter 7 for a description of the trips supported by the Inverter.

# 6-34 Programming Your Application

## MMI Menu Map

- 1 SETUP PARAMETERS
- 2 FUNCTION BLOCKS
- 3 TRIPS
- 4 I\*t TRIP
  - I\*t THRESHOLD
  - I\*t TIME
  - I\*t UPPER LIMIT

## I\*t TRIP

This function block is designed to protect the motor and the Inverter from damage that may be caused by continuous operation beyond specification.

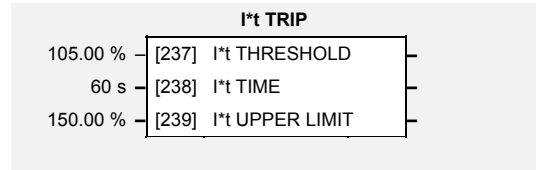

## Parameter Descriptions

### I\*t THRESHOLD

*Range: 50.00 to 105.00 %*

If the magnitude of the current delivered by the Inverter is greater than this threshold then the Inverter will trip after a time determined by I\*t TIME and I\*t UPPER LIMIT .

This parameter must be less than the I\*t UPPER LIMIT .

### I\*t TIME

*Range: 5 to 60 s*

The trip delay time for a constant output current equivalent to I\*t UPPER LIMIT .

### I\*t UPPER LIMIT

*Range: 50.00 to 150.00 %*

The output current level used to determine the trip delay. Used in conjunction with I\*t TIME .

This parameter must be greater than I\*t THRESHOLD .

## Functional Description

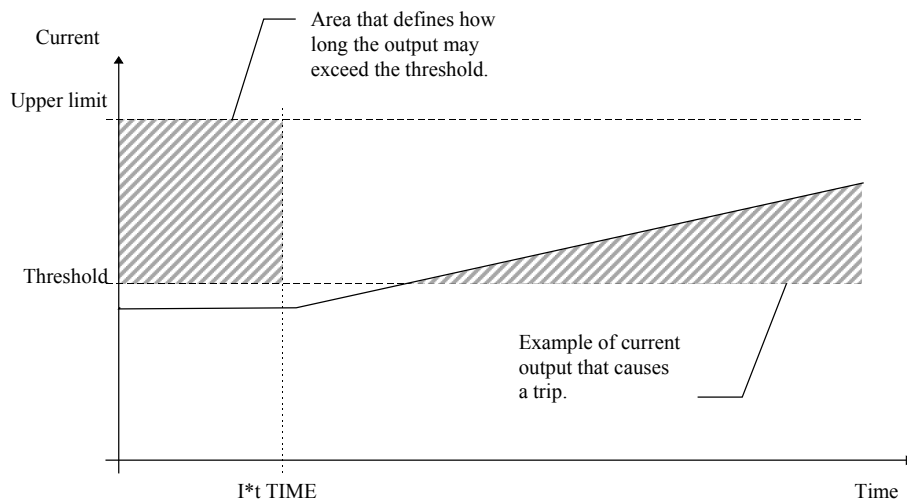

The I\*t UPPER LIMIT, I\*t THRESHOLD and I\*t TIME parameters effectively define how long the output current may exceed the I\*t THRESHOLD . For example, if the output current equals the I\*t UPPER LIMIT then the trip will occur after I\*t TIME . Alternatively, if the output current exceeds the I\*t THRESHOLD by only half as much as the I\*t UPPER LIMIT then the trip will occur after twice the I\*t TIME .

As the output current is constantly monitored by the Inverter the I\*t TRIP block constantly updates the time at which a trip might occur, taking into account not only the present output level but also the recent history. For an output current that moves around the I\*t THRESHOLD level, the time for which the current is below the level is used to balance the time for which the current is above the level. This avoids spurious trips while maintaining the monitoring function.

Refer to Chapter 7 for a description of the trips supported by the Inverter.

## MMI Menu Map

- 1 SETUP PARAMETERS
- 2 FUNCTION BLOCKS
- 3 SEQ & REF
- 4 JOG
  - JOG SETPOINT
  - JOG ACCEL RATE
  - JOG DECEL RATE

## JOG

This block holds all the parameters that concern the Jog functionality on the Inverter.

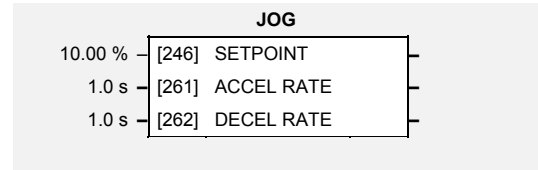

## Parameter Descriptions

### SETPOINT

*Range: 0.00 to 100.00 %*

The setpoint is the target reference that the Inverter will ramp to. Direction is taken from the current mode, (LOCAL or REMOTE).

### ACCEL RATE

*Range: 0.0 to 600.0 s*

The jog mode acceleration rate.

### DECEL RATE

*Range: 0.0 to 600.0 s*

The jog mode deceleration rate.

## Functional Description

The JOG function block is used to configure the action of the Inverter when used in jog mode. The various operating modes are described in more detail in Chapter 4: “Operating the Inverter” - The Start/Stop Mode Explained.

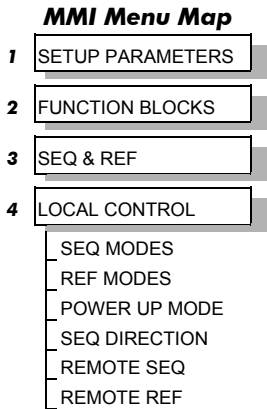

## LOCAL CONTROL

This block allows the available modes of Local and Remote operation to be customised. It also indicates the selected mode.

Switching between Local and Remote modes can only be done using the Operator Station. Refer to Chapter 5: “The Operator Station” - The L/R Key.

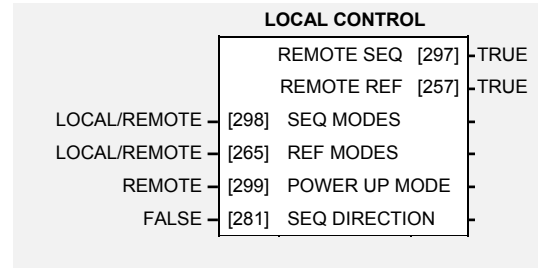

## Parameter Descriptions

### SEQ MODES

*Range: Enumerated - see below*

Allows the source of sequencing commands to be selected. Local is the Operator Station, Remote is an external signal. The modes supported are:

*Enumerated Value : Seq Mode*

- 0 : LOCAL/REMOTE
- 1 : LOCAL ONLY
- 2 : REMOTE ONLY

### REF MODES

*Range: Enumerated - see below*

Allows the source of the reference signal to be selected. Local is the Operator Station, Remote is an external signal. The modes supported are:

*Enumerated Value : Ref Mode*

- 0 : LOCAL/REMOTE
- 1 : LOCAL ONLY
- 2 : REMOTE ONLY

### POWER UP MODE

*Range: Enumerated - see below*

Allows the power-up operating mode of the Inverter to be selected. Local is the Operator Station, Remote is an external signal, Automatic is the same mode as at power-down. The modes supported are:

*Enumerated Value : Power Up Mode*

- 0 : LOCAL
- 1 : REMOTE
- 2 : AUTOMATIC

### SEQ DIRECTION

*Range: FALSE / TRUE*

When TRUE, direction is a Sequencing command.

When FALSE, direction is a Reference command.

### REMOTE SEQ

*Range: FALSE / TRUE*

This parameter indicates the present source of the sequencing commands.

### REMOTE REF

*Range: FALSE / TRUE*

This parameter indicates the present source of the reference signal.

## LOGIC FUNCTION

These generic function blocks can be configured to perform one of a number of simple functions upon a fixed number of inputs.

**MMI Menu Map**

- 1 SETUP PARAMETERS
- 2 FUNCTION BLOCKS
- 3 MISCELLANEOUS
- 4 LOGIC FUNCTION
- 5 LOGIC FUNC 1
- 5 LOGIC FUNC 2
- 5 LOGIC FUNC 3
- 5 LOGIC FUNC 4
- 5 LOGIC FUNC 5
- 5 LOGIC FUNC 6
- 5 LOGIC FUNC 7
- 5 LOGIC FUNC 8
- 5 LOGIC FUNC 9
- 5 LOGIC FUNC 10

- INPUT A
- INPUT B
- INPUT C
- TYPE
- OUTPUT

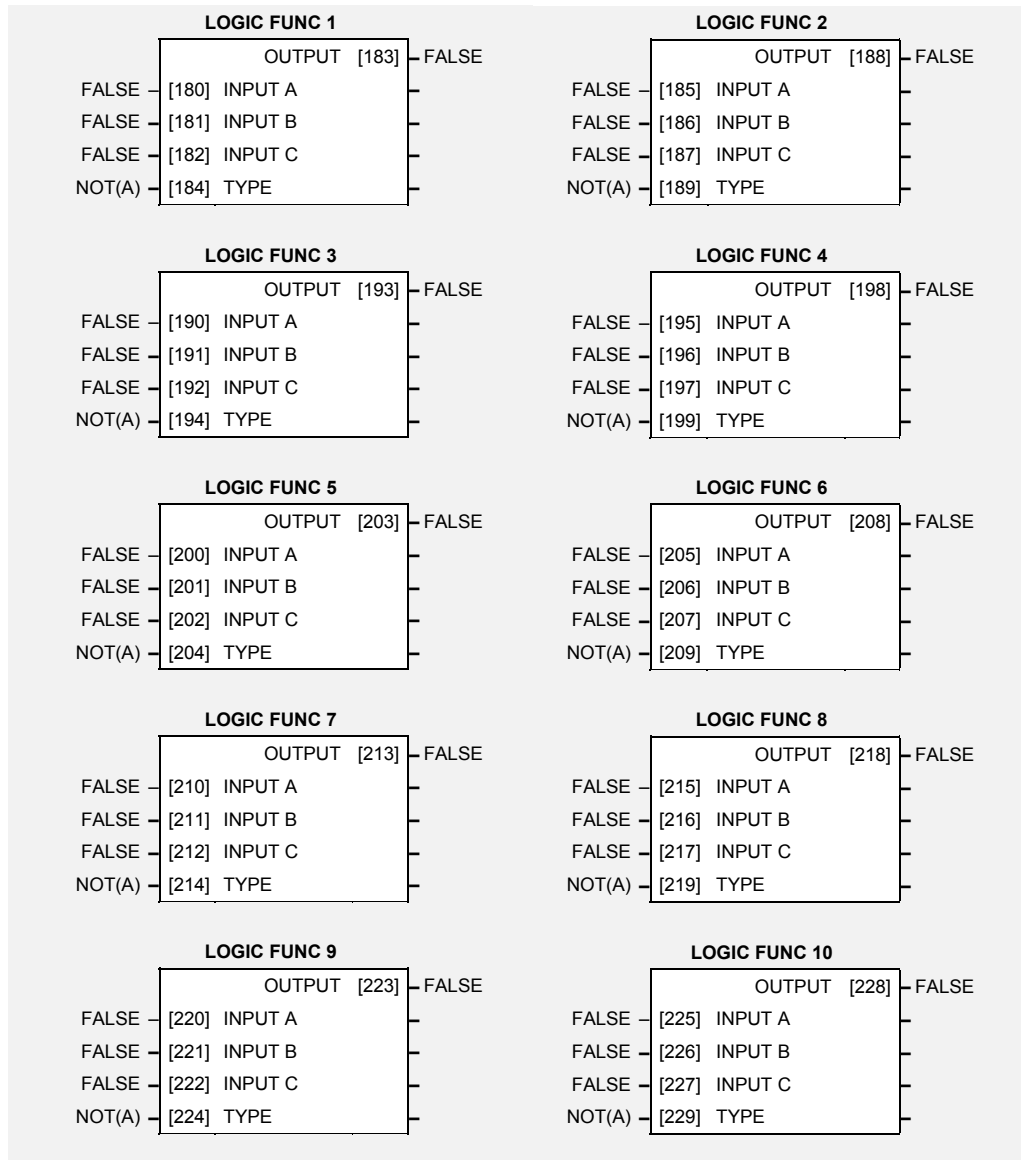

## Parameter Descriptions

### INPUT A

General purpose logic input.

*Range: FALSE / TRUE*

### INPUT B

General purpose logic input.

*Range: FALSE / TRUE*

### INPUT C

General purpose logic input.

*Range: FALSE / TRUE*

# 6-38 Programming Your Application

**TYPE**

*Range: Enumerated - see below*

The operation to be performed on the three inputs to produce the output value. The operations that can be selected are:

- Enumerated Value : Type*
- 0 : NOT(A)
  - 1 : AND(A,B,C)
  - 2 : NAND(A,B,C)
  - 3 : OR(A,B,C)
  - 4 : NOR(A,B,C)
  - 5 : XOR(A,B)
  - 6 : 0-1 EDGE(A)
  - 7 : 1-0 EDGE(A)
  - 8 : AND(A,B,!C)
  - 9 : OR(A,B,!C)
  - 10 : S FLIP-FLOP
  - 11 : R FLIP-FLOP

**OUTPUT**

*Range: FALSE / TRUE*

The result of performing the selected operation on the inputs.

## Functional Description

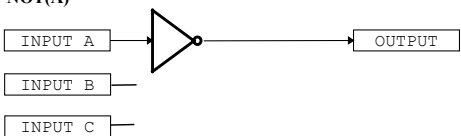
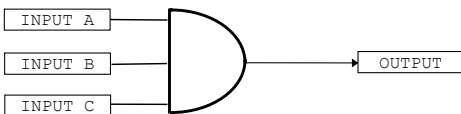
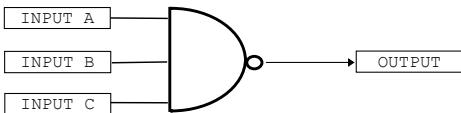
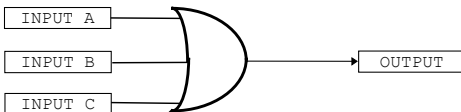
Operation	Description
NOT(A)	<p><b>NOT(A)</b></p>  <p>If INPUT A is TRUE the OUTPUT is FALSE, otherwise the OUTPUT is TRUE.</p>
AND(A,B,C)	<p><b>AND(A,B,C)</b></p>  <p>If A and B and C are all TRUE then the OUTPUT is TRUE, otherwise the OUTPUT is FALSE.</p>
NAND(A,B,C)	<p><b>NAND(A,B,C)</b></p>  <p>If A and B and C are all TRUE then the OUTPUT is FALSE, otherwise the OUTPUT is TRUE.</p>
OR(A,B,C)	<p><b>OR(A,B,C)</b></p>  <p>If at least one of A or B or C is TRUE then the OUTPUT is TRUE, otherwise the OUTPUT is FALSE.</p>

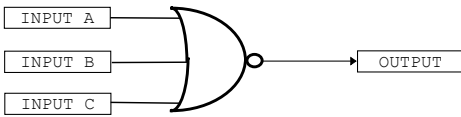
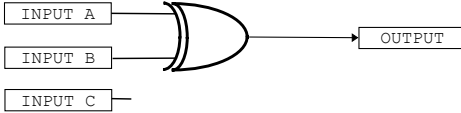
Operation	Description
<p>NOR(A,B,C)</p> 	<p><b>NOR(A,B,C)</b></p> <p>If at least one of A or B or C is TRUE then the OUTPUT is FALSE, otherwise the OUTPUT is TRUE.</p>
<p>XOR(A,B)</p> 	<p><b>XOR(A,B)</b></p> <p>If A and B are the same, (both TRUE or both FALSE), then the output is FALSE, otherwise the output is TRUE.</p>

### 0-1 EDGE(A)

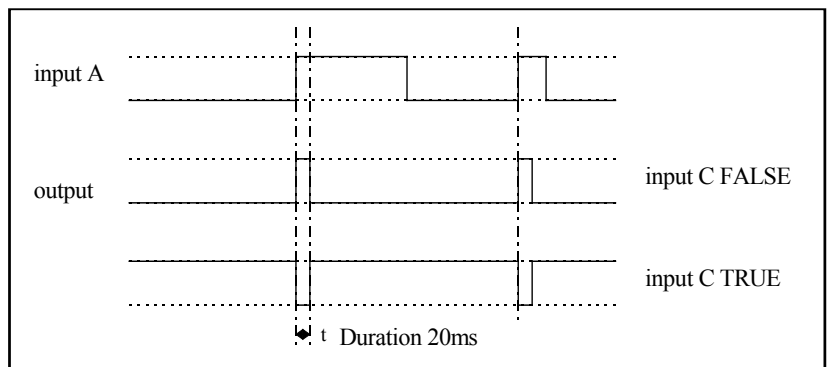

#### Rising Edge Trigger

Input B is not used.

This function outputs a pulse of 20ms duration when INPUT A to the block becomes TRUE. When INPUT C is TRUE, the output is inverted.

### 1-0 EDGE(A)

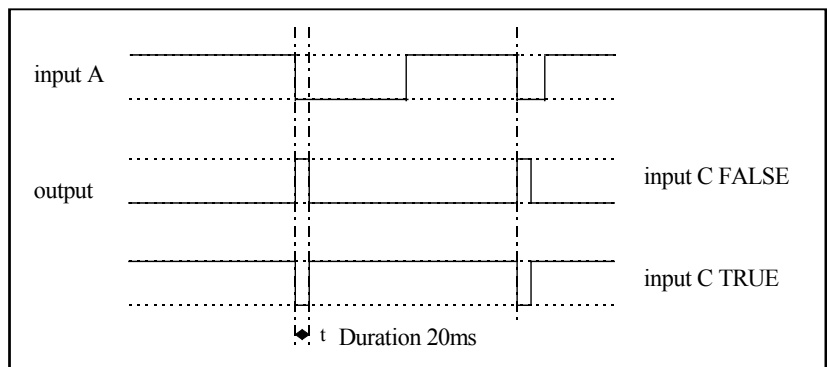

#### Falling Edge Trigger

Input B is not used.

This function outputs a pulse of 20ms duration when INPUT A to the block becomes FALSE. When INPUT C is TRUE, the output is inverted.

# 6-40 Programming Your Application

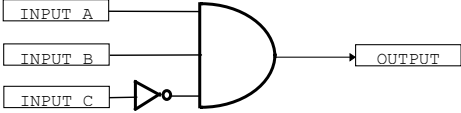
Operation	Description																																								
AND(A,B,!C)	<p><b>AND(A,B,!C)</b></p>  <p>Refer to the Truth Table. FALSE = 0, TRUE = 1.</p> <table border="1"> <thead> <tr> <th colspan="3">Input State</th> <th>Output State</th> </tr> <tr> <th>A</th> <th>B</th> <th>C</th> <th>Output State</th> </tr> </thead> <tbody> <tr><td>0</td><td>0</td><td>0</td><td>0</td></tr> <tr><td>0</td><td>0</td><td>1</td><td>0</td></tr> <tr><td>0</td><td>1</td><td>0</td><td>0</td></tr> <tr><td>0</td><td>1</td><td>1</td><td>0</td></tr> <tr><td>1</td><td>0</td><td>0</td><td>0</td></tr> <tr><td>1</td><td>0</td><td>1</td><td>0</td></tr> <tr><td>1</td><td>1</td><td>0</td><td>1</td></tr> <tr><td>1</td><td>1</td><td>1</td><td>0</td></tr> </tbody> </table>	Input State			Output State	A	B	C	Output State	0	0	0	0	0	0	1	0	0	1	0	0	0	1	1	0	1	0	0	0	1	0	1	0	1	1	0	1	1	1	1	0
Input State			Output State																																						
A	B	C	Output State																																						
0	0	0	0																																						
0	0	1	0																																						
0	1	0	0																																						
0	1	1	0																																						
1	0	0	0																																						
1	0	1	0																																						
1	1	0	1																																						
1	1	1	0																																						

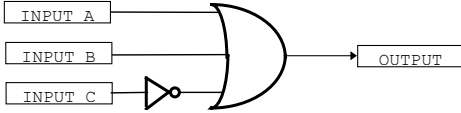
OR(A,B,!C)	<p><b>OR(A,B,!C)</b></p>  <p>Refer to the Truth Table. FALSE = 0, TRUE = 1.</p> <table border="1"> <thead> <tr> <th colspan="3">Input State</th> <th>Output State</th> </tr> <tr> <th>A</th> <th>B</th> <th>C</th> <th>Output State</th> </tr> </thead> <tbody> <tr><td>0</td><td>0</td><td>0</td><td>1</td></tr> <tr><td>0</td><td>0</td><td>1</td><td>0</td></tr> <tr><td>0</td><td>1</td><td>0</td><td>1</td></tr> <tr><td>0</td><td>1</td><td>1</td><td>1</td></tr> <tr><td>1</td><td>0</td><td>0</td><td>1</td></tr> <tr><td>1</td><td>0</td><td>1</td><td>1</td></tr> <tr><td>1</td><td>1</td><td>0</td><td>1</td></tr> <tr><td>1</td><td>1</td><td>1</td><td>1</td></tr> </tbody> </table>	Input State			Output State	A	B	C	Output State	0	0	0	1	0	0	1	0	0	1	0	1	0	1	1	1	1	0	0	1	1	0	1	1	1	1	0	1	1	1	1	1
Input State			Output State																																						
A	B	C	Output State																																						
0	0	0	1																																						
0	0	1	0																																						
0	1	0	1																																						
0	1	1	1																																						
1	0	0	1																																						
1	0	1	1																																						
1	1	0	1																																						
1	1	1	1																																						

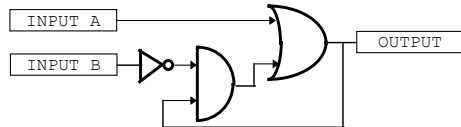
S FLIP-FLOP	<p><b>S FLIP-FLOP</b></p>  <p>This is a set dominant flip-flop. INPUT A functions as <i>set</i>, and INPUT B as <i>reset</i>.</p>
-------------	---

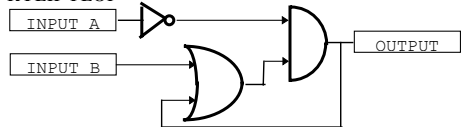
R FLIP-FLOP	<p><b>R FLIP-FLOP</b></p>  <p>This is a reset dominant flip-flop. INPUT A functions as <i>reset</i>, and INPUT B as <i>set</i>.</p>
-------------	---

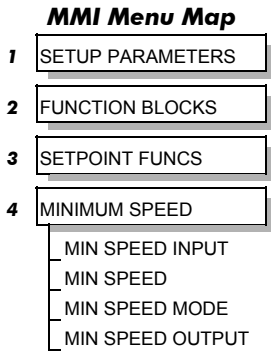

## MINIMUM SPEED

The minimum speed block is used to determine how the Inverter will follow a reference. There are two modes

1. Proportional : minimum limit
2. Linear : between min and max.

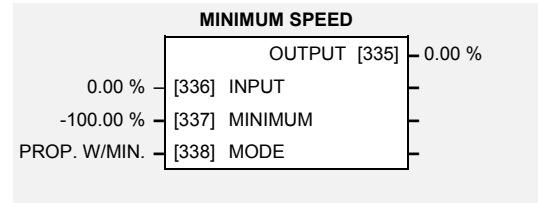

## Parameter Descriptions

### INPUT

The input for this block.

Range: -300.00 to 300.00 %

### MINIMUM

This parameter determines the minimum output value from this block

Range: -100.00 to 100.00 %

### MODE

This parameter represents the operating mode of the block. There are two modes:

Range: Enumerated - see below

*Enumerated Value : Operating Mode*

- 0 : PROP. W/MIN.
- 1 : LINEAR

### OUTPUT

The output is determined by the MODE selected, see below.

Range: xxx.xx %

## Functional Description

There are two operating modes for the MINIMUM SPEED block:

### Proportional with Minimum

In this mode the MINIMUM SPEED block behaves like a simple clamp. The minimum value has the valid range -100% to 100% and the output is always greater than or equal to the minimum value.

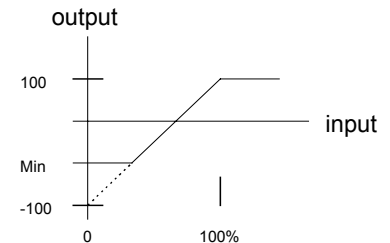

### Linear

In this mode the MINIMUM SPEED block first clamps the input to zero then rescales the input such that the output goes linearly between minimum and 100% for an input that goes from 0 to 100%.

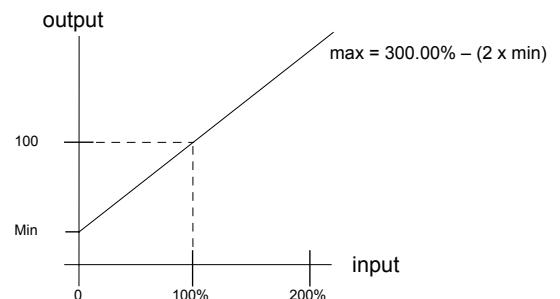

Note the constraints:-

- min  $\geq$  0
- input  $\geq$  0
- max = 100%

## MMI Menu Map

- 1 SETUP PARAMETERS
- 2 FUNCTION BLOCKS
- 3 MISCELLANEOUS
- 4 MULTIPLEXER
  - INPUT 0
  - INPUT 1
  - INPUT 2
  - INPUT 3
  - INPUT 4
  - INPUT 5
  - INPUT 6
  - INPUT 7
  - INPUT 8
  - INPUT 9
  - INPUT 10
  - INPUT 11
  - INPUT 12
  - INPUT 13
  - INPUT 14
  - INPUT 15
  - OUTPUT

## MULTIPLEXER

This block collects together 16 Boolean input values into a single word.

This may be used to set and clear individual bits within a word such as the TRIGGERS 1 word for the AUTO RESTART function block.

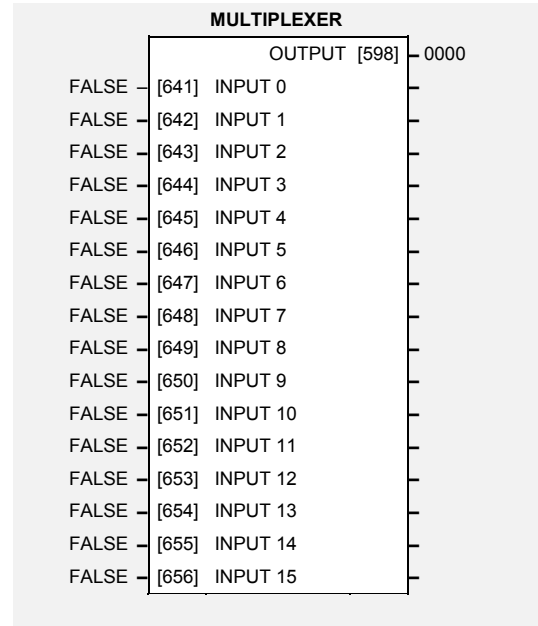

## Parameter Descriptions

### INPUT 0 TO INPUT 15

The Boolean inputs to be assembled into a single word.

*Range: FALSE / TRUE*

### OUTPUT

The resulting word.

*Range: 0000 to FFFF*

## OPERATOR MENU

This function block is used to customise the Operator menu, the default menu displayed at start-up.

By entering parameter tag numbers, you can assign which parameters will be in the menu, and their order of appearance.

This function block also assigns the parameter that will be displayed immediately after the power-up screen.

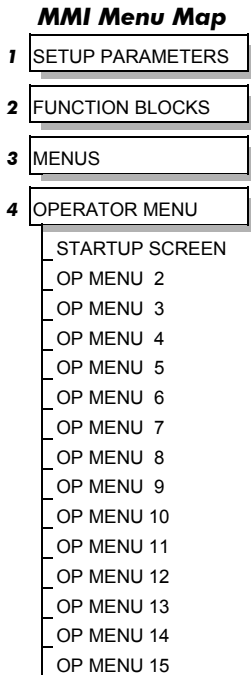

OPERATOR MENU		
1	[93]	STARTUP SCREEN
255	[626]	OP MENU 2
591	[627]	OP MENU 3
67	[628]	OP MENU 4
72	[629]	OP MENU 5
75	[630]	OP MENU 6
370	[631]	OP MENU 7
0	[632]	OP MENU 8
0	[633]	OP MENU 9
0	[634]	OP MENU 10
0	[635]	OP MENU 11
0	[636]	OP MENU 12
0	[637]	OP MENU 13
0	[638]	OP MENU 14
0	[639]	OP MENU 15

## Parameter Descriptions

### STARTUP SCREEN

*Range: 0 to 15*

Selects which of the parameters will be displayed immediately after the startup screen. The range refers to the OPERATOR MENU numbers below. Whichever parameter is selected by the relevant OPERATOR MENU will be displayed as the Startup screen.

- A value of 0 selects the Welcome screen to be displayed (refer to CONFIGURATION ID parameter in the OP STATION function block).
- A value of 1 selects the REMOTE SETPOINT or LOCAL SETPOINT parameter to be displayed.
- A value of 2 to 15 selects the corresponding entry in the Operator menu to be displayed.

### OP MENU 2 to 15

*Range: See the table below*

Selects a parameter screen for the OPERATOR menu. Enter the parameter's tag number. Each entry in the menu may be set to the tag number of any visible parameter within the Inverter. There are also four special tag numbers:

- 0 Prevents this entry from displaying in the Operator menu
- 1000 Displays the current setpoint (Local, Remote, Jog)
- 1001 Displays the CUSTOM SCREEN 1
- 1002 Displays the CUSTOM SCREEN 2

## Functional Description

The Operator menu consists of up to 16 entries, including the Startup screen. OP MENU 1 (not included in the function block) is fixed to always be the active setpoint or speed demand. The remaining 14 entries (OP MENU 2 to OP MENU 15) may be customised to show any parameter in the Inverter.

The default (Macro 1) tags for the OPERATOR menu display the following parameters:

255: SPEED DEMAND  
 591: DRIVE FREQUENCY  
 67: MOTOR CURRENT  
 72: LOAD  
 75: DC LINK VOLTS  
 370: CURRENT LIMITING

Also, the Startup screen is selected to display OPERATOR MENU 1, which is fixed to display the SETPOINT parameter.

## OP STATION

The operator station block allows the operation of the Operator Station to be customised.

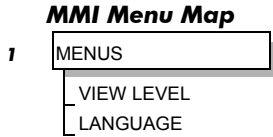
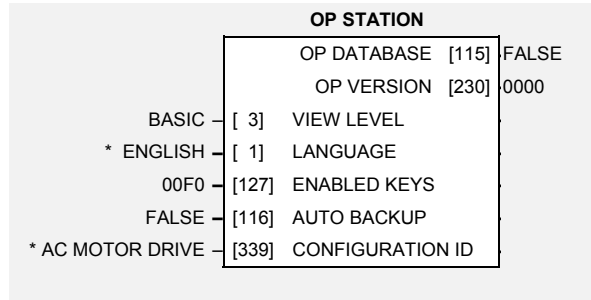

or

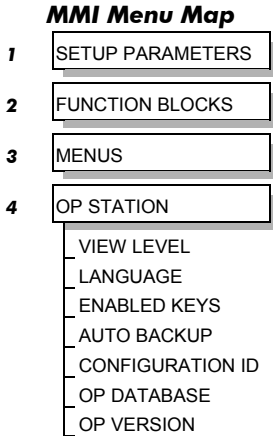

## Parameter Descriptions

### VIEW LEVEL

Range: Enumerated - see below

The menu to be displayed by the Operator Station.

Enumerated Value : Viewing Level

- 0 : OPERATOR
- 1 : BASIC
- 2 : ADVANCED

### LANGUAGE

Range: Enumerated - see below

The display language for the menu.

Enumerated Value : Language

- 0 : ENGLISH
- 1 : DEUTSCH
- 2 : FRANCAIS
- 3 : ESPANOL

### ENABLED KEYS

Range: 0000 to FFFF

The following keys on the Operator Station can be enabled or disabled separately. The combination produces the parameter setting as in the table below.

Parameter Setting	RUN	L/R	JOG	DIR
0000	-	-	-	-
0010	-	-	-	ENABLED
0020	-	-	ENABLED	-
0030	-	-	ENABLED	ENABLED
0040	-	ENABLED	-	-
0050	-	ENABLED	-	ENABLED
0060	-	ENABLED	ENABLED	-
0070	-	ENABLED	ENABLED	ENABLED
0080	ENABLED	-	-	-
0090	ENABLED	-	-	ENABLED
00A0	ENABLED	-	ENABLED	-
00B0	ENABLED	-	ENABLED	ENABLED
00C0	ENABLED	ENABLED	-	-
00D0	ENABLED	ENABLED	-	ENABLED
00E0	ENABLED	ENABLED	ENABLED	-
00F0	ENABLED	ENABLED	ENABLED	ENABLED

**AUTO BACKUP**

*Range: FALSE / TRUE*

When this input is set to TRUE, performing a SAVE TO MEMORY function block operation also saves the configuration of the Inverter to the connected Operator Station.

**CONFIGURATION ID**

*Range: 16 characters*

This 16 character string is displayed as the top line of the Welcome screen.

**OP DATABASE**

*Range: FALSE / TRUE*

When TRUE, this diagnostic output indicates that the connected Operator Station contains a configuration that may be loaded into the Inverter.

**OP VERSION**

*Range: 0000 to FFFF*

Displays the software version of the Operator Station. It is cleared to 0000 if no Operator Station is connected.

## MMI Menu Map

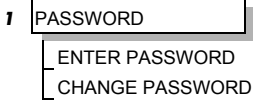

or

## MMI Menu Map

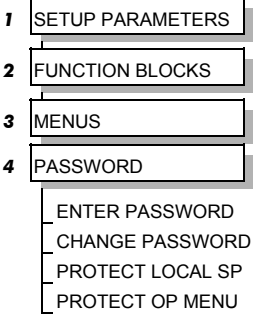

## PASSWORD

This function block contains options associated with password protection for the Operator Station.

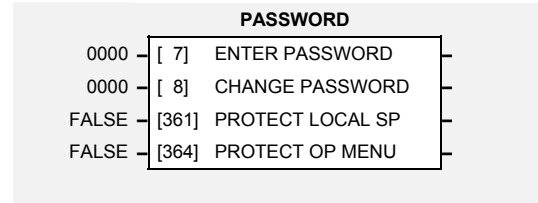

## Parameter Descriptions

### ENTER PASSWORD

Range: 0000 to FFFF

Entering a password equal to the password held in the inverter unlocks the Operator Station. Entering a value that is not equal to the password held in the inverter locks the Operator Station. When locked, no parameters in the inverter may be modified from the Operator Station (with the possible exception of the parameters in the OPERATOR menu, see PROTECT OP MENU below).

### CHANGE PASSWORD

Range: 0000 to FFFF

This parameter is used to initially set and if necessary change the password held in the inverter. When the password is set to 0000, the Operator Station is always unlocked.

### PROTECT LOCAL SP

Range: FALSE / TRUE

Enables password protection of the local setpoint. When set to TRUE, the local setpoint is read-only whenever the inverter is password locked. When FALSE, the local setpoint can be adjusted regardless of the password.

### PROTECT OP MENU

Range: FALSE / TRUE

Enables password protection of all parameters shown in the OPERATOR menu (except for the local setpoint entry). When set to TRUE, the parameters are read-only whenever the inverter is password locked. When FALSE, the parameters can be adjusted regardless of the password.

## MMI Menu Map

- 1 SETUP PARAMETERS
- 2 FUNCTION BLOCKS
- 3 MOTOR CONTROL
- 4 PATTERN GEN
  - RANDOM PATTERN
  - PATTERN GEN FREQ
  - DEFLUX DELAY
  - DRIVE FREQUENCY
  - VOLTS
  - BOOST

## PATTERN GEN

The pattern generator function block allows the user to configure the Inverter PWM (Pulse Width Modulator) operation.

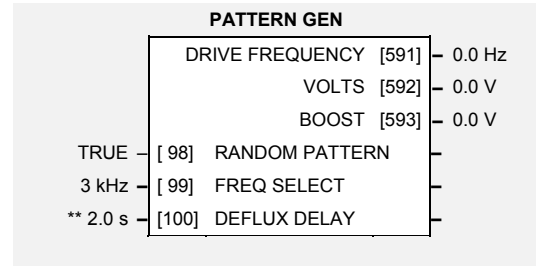

## Parameter Descriptions

### RANDOM PATTERN

Range: *FALSE / TRUE*

This parameter selects between random pattern (quiet motor noise) or the more conventional fixed carrier PWM strategies. When TRUE, random pattern is enabled.

### FREQ SELECT

Range: *Enumerated - see below*

This parameter selects the base switching frequency of the output power stack. The choices of switching frequency are:

*Enumerated Value : Frequency*

- 0 : 3 kHz
- 1 : 6 kHz
- 2 : 9 kHz

The higher the switching frequency, the lower the level of motor audible noise. However, this is only achieved at the expense of increased Inverter losses.

*Note: This parameter is internally clamped to 3kHz on 0.75kW, 380/460V units.*

### DEFLUX DELAY

Range: *0.1 to 10.0 s*

Sets the minimum allowed delay between disabling and then re-enabling PWM production (i.e. stopping and starting the drive).

### DRIVE FREQUENCY

Range: *xxxx.x Hz*

The Inverter output frequency.

### VOLTS

Range: *xxxx.x V*

The Inverter output volts.

### BOOST

Range: *xxxx.x V*

The Inverter output boost.

## Functional Description

The Inverter provides a unique quiet pattern PWM strategy in order to reduce audible motor noise. The user is able to select between the quiet pattern or the more conventional fixed carrier frequency method. With the quiet pattern strategy selected (random pattern enabled), audible motor noise is reduced to a dull hiss.

In addition, the user is able to select the PWM carrier frequency. This is the main switching frequency of the power output stage of the Frequency Inverter. A high setting of carrier frequency (e.g. 9kHz) reduces audible motor noise but only at the expense of higher Inverter losses and smooth motor rotation at low output frequencies. A low setting of carrier frequency (e.g. 3kHz), reduces Inverter losses but increases audible motor noise.

# 6-48 Programming Your Application

## MMI Menu Map

1	SETUP PARAMETERS
2	FUNCTION BLOCKS
3	SETPOINT FUNCS
4	PID
	PID SETPOINT
	PID FEEDBACK
	PID SP NEGATE
	PID FB NEGATE
	PID ENABLE
	PID INTEGRAL OFF
	PID P GAIN
	PID I TIME CONST
	PID D TIME CONST
	PID FILTER TC
	PID OUT POS LIM
	PID OUT NEG LIM
	PID OUT SCALING
	PID OUTPUT

## PID

This function block allows the Inverter to be used in applications requiring a trim to the setpoint, depending on feedback from an external measurement device. Typically this will be used for process control, i.e. pressure or flow.

PID	
	PID OUTPUT [320] 0.00 %
	PID ERROR [766] 0.00 %
0.00 %	[310] SETPOINT
0.00%	[764] FEEDBACK
FALSE	[763] SETPOINT NEGATE
FALSE	[765] FEEDBACK NEGATE
FALSE	[311] ENABLE
FALSE	[312] INTEGRAL DEFEAT
1.0	[313] P GAIN
1.00 s	[314] I TIME CONST
0.000 s	[315] D TIME CONST
2.000 s	[316] FILTER TC
100.00 %	[317] OUTPUT POS LIMIT
-100.00 %	[318] OUTPUT NEG LIMIT
1.0000	[319] OUTPUT SCALING

## Parameter Descriptions

### SETPOINT

An input to the PID block.

Range: -300.00 to 300.00 %

### FEEDBACK

An input to the PID block.

Range: -300.00 to 300.00 %

### SETPOINT NEGATE

Changes the sign of SETPOINT.

Range: FALSE / TRUE

### FEEDBACK NEGATE

Changes the sign of FEEDBACK.

Range: FALSE / TRUE

### ENABLE

This parameter globally resets the PID output and integral term when FALSE. This parameter must be TRUE for the PID to operate.

Range: FALSE / TRUE

### INTEGRAL DEFEAT

This parameter resets the PID integral term when TRUE.

Range: FALSE / TRUE

### P GAIN

This parameter is the true proportional gain of the PID controller. With a P gain of zero, the PID output would be zero.

Range: 0.0 to 100.0

### I TIME CONST

The integral time constant of the PID controller.

Range: 0.01 to 100.00 s

## D TIME CONST

Range: 0.000 to 10.000 s

The derivative time constant of the PID controller.

## FILTER TC

Range: 0.000 to 10.000 s

In order to help attenuate high frequency noise on the PID output, a first order output filter has been provided. This parameter determines the output filter time constant.

## OUTPUT POS LIMIT

Range: 0.00 to 105.00 %

This parameter determines the maximum positive excursion (Limit) of the PID output.

## OUTPUT NEG LIMIT

Range: -105.00 to 0.00 %

This parameter determines the maximum negative excursion (Limit) of the PID output.

## OUTPUT SCALING

Range: -3.0000 to 3.0000

This parameter represents an overall scaling factor which is applied after the PID positive and negative limit clamps.

## PID OUTPUT

Range: xxx.xx %

The output of the PID function.

## PID ERROR

Range: xxx.xx %

The result of SETPOINT - FEEDBACK, clamped to between  $\pm 100.00\%$ .

## Functional Description

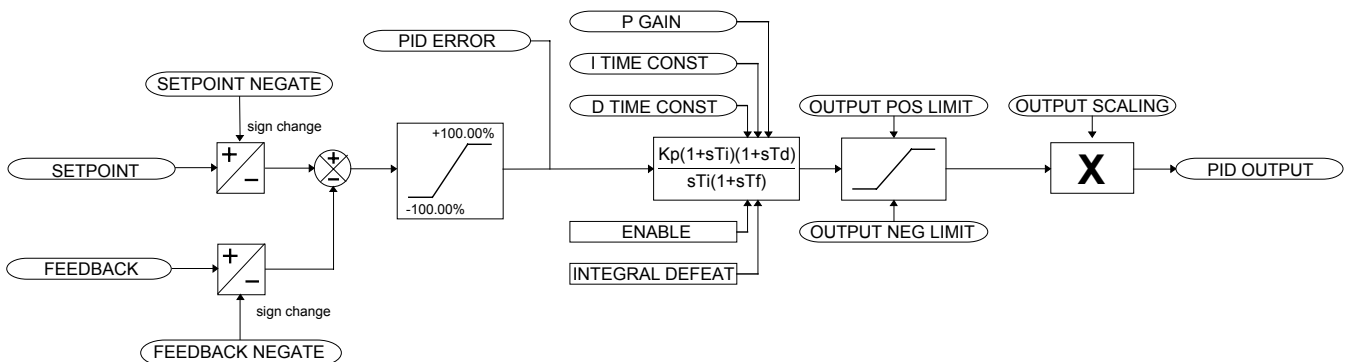

For an application that requires closed loop control, the error term may be derived from the setpoint and feedback using a value function block. This error term is then used by the PID. The output of the PID may be used to trim the demand setpoint via the SPEED TRIM parameter in the REFERENCE function block.

## PRESET

The Inverter has eight Preset function blocks. They are used to select a value from one of eight inputs, depending on the value of another input. A second output is provided to allow the block to be used as two banks of four inputs.

### MMI Menu Map

- 1 SETUP PARAMETERS
- 2 FUNCTION BLOCKS
- 3 SETPOINT FUNCS
- 4 PRESET
- 5 PRESET 1
- 5 PRESET 2
- 5 PRESET 3
- 5 PRESET 4
- 5 PRESET 5
- 5 PRESET 6
- 5 PRESET 7
- 5 PRESET 8
  - PRESET 8 SELECT
  - PRESET 8 INPUT 0
  - PRESET 8 INPUT 1
  - PRESET 8 INPUT 2
  - PRESET 8 INPUT 3
  - PRESET 8 INPUT 4
  - PRESET 8 INPUT 5
  - PRESET 8 INPUT 6
  - PRESET 8 INPUT 7
  - PRESET 8 OUTPUT1
  - PRESET 8 OUTPUT2

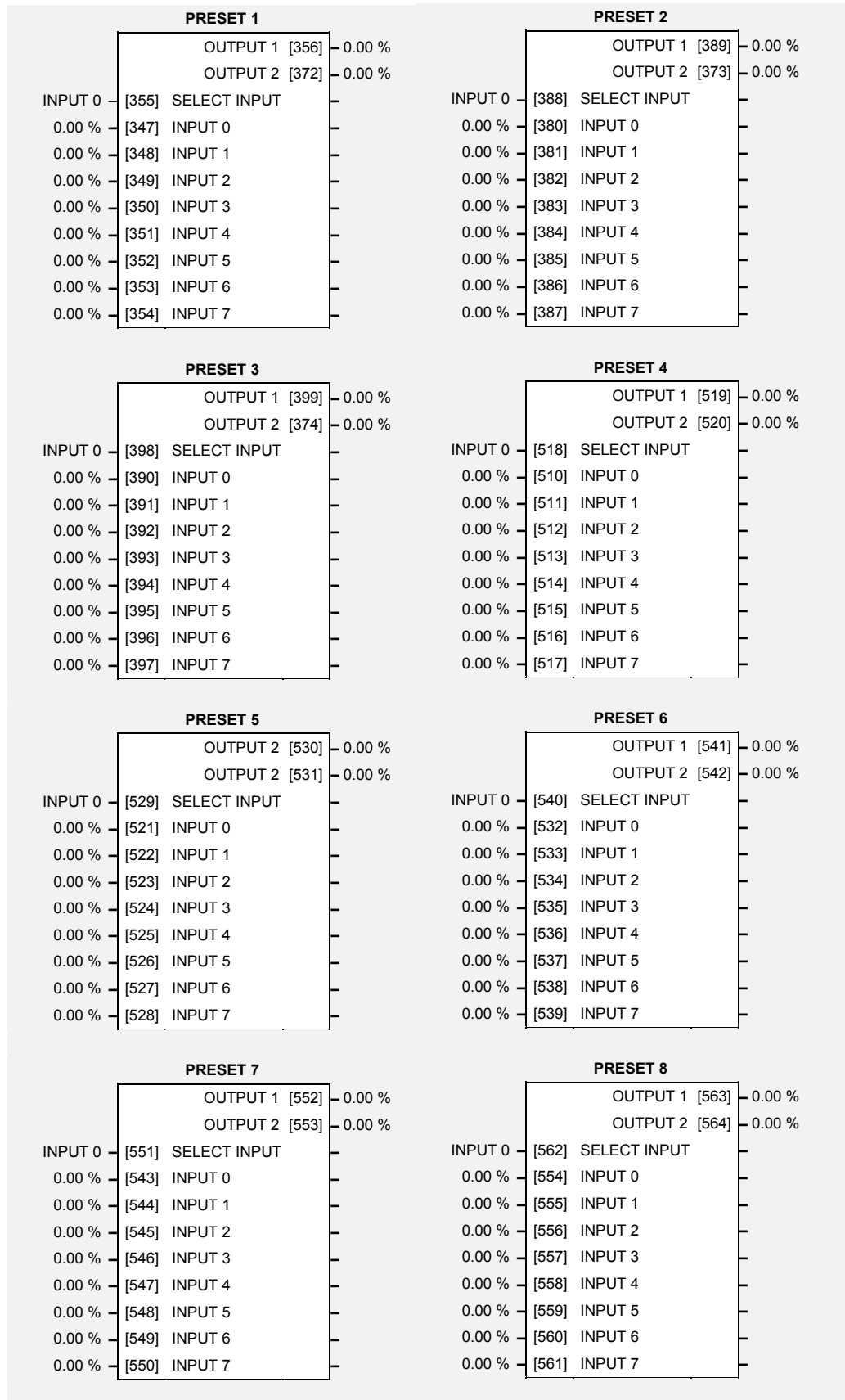

## Parameter Descriptions

### SELECT INPUT

*Range: Enumerated - see below*

Determines which of the inputs is routed to OUTPUT 1 . In addition, if SELECT INPUT is in the range 0 to 3, INPUT 4 to INPUT 7 respectively is routed to OUTPUT 2.

*Enumerated Value : Select Input*

- 0 : INPUT 0
- 1 : INPUT 1
- 2 : INPUT 2
- 3 : INPUT 3
- 4 : INPUT 4
- 5 : INPUT 5
- 6 : INPUT 6
- 7 : INPUT 7

### INPUT 0 TO INPUT 7

Inputs to the Preset block.

*Range: -300.00 to 300.00 %*

### OUTPUT 1

Selected input.

*Range: xxx.xx %*

### OUTPUT 2

Selected input (if SELECT INPUT is in the correct range).

*Range: xxx.xx %*

## Functional Description

The Preset function block is a de-multiplexer.

OUTPUT 1 and OUTPUT 2 return the values at selected inputs set by SELECT INPUT.

OUTPUT 2 returns the value of a different input to OUTPUT 1 , i.e:

if SELECT INPUT = 0 then OUTPUT 1 = INPUT 0, OUTPUT 2 = INPUT 4

if SELECT INPUT = 1 then OUTPUT 1 = INPUT 1, OUTPUT 2 = INPUT 5 etc.

When SELECT INPUT is set to 4, 5, 6 or 7, OUTPUT 2 will return a value of zero.

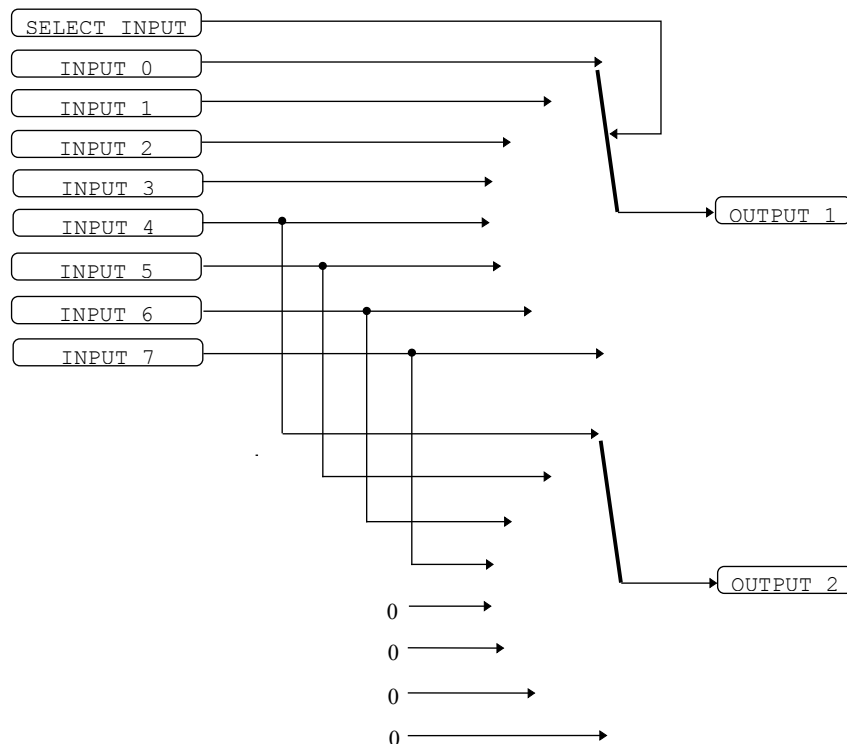

## MMI Menu Map

- 1 SETUP PARAMETERS
- 2 FUNCTION BLOCKS
- 3 SETPOINT FUNCS
- 4 RAISE/LOWER
  - RAISE INPUT
  - LOWER INPUT
  - RL RAMP RATE
  - RL MAX VALUE
  - RL MIN VALUE
  - RL RESET VALUE
  - RL RESET
  - RAISE/LOWER OUT

## RAISE/LOWER

This function block acts as an internal motorised potentiometer (MOP).

The OUTPUT is preserved during the power-down of the Inverter.

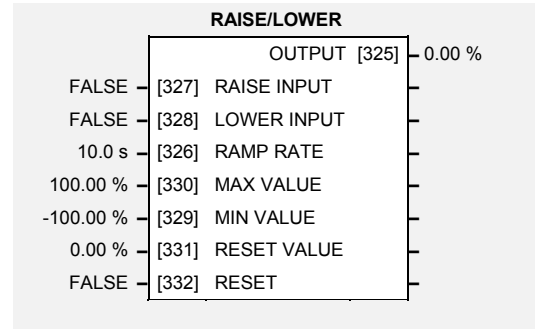

## Parameter Descriptions

### RAISE INPUT

When TRUE causes OUTPUT to ramp up.

Range: FALSE / TRUE

### LOWER INPUT

When TRUE causes OUTPUT to ramp down.

Range: FALSE / TRUE

### RAMP RATE

Rate of change of the OUTPUT . Defined as time to change from 0.00% to 100.00% . Note that the raise and lower rates are always the same.

Range: 0.0 to 600.0 s

### MAX VALUE

The maximum value to which OUTPUT will ramp up to.

Range: -300.00 to 300.00 %

### MIN VALUE

The minimum value to which OUTPUT will ramp down to.

Range: -300.00 to 300.00 %

### RESET VALUE

The value the OUTPUT is set to when RESET is TRUE.

Range: -300.00 to 300.00 %

### RESET

When TRUE, forces OUTPUT to track RESET VALUE .

Range: FALSE / TRUE

### OUTPUT

The ramped output. This parameter is persistent, that is, it is saved throughout a power failure.

Range: xxx.xx %

## Functional Description

The table below describes how OUTPUT is controlled by the RAISE INPUT, LOWER INPUT and RESET inputs.

RESET	RAISE INPUT	LOWER INPUT	Action
TRUE	Any	Any	OUTPUT tracks RESET VALUE
FALSE	TRUE	FALSE	OUTPUT ramps up to MAX VALUE at RAMP RATE
FALSE	FALSE	TRUE	OUTPUT ramps down to MIN VALUE at RAMP RATE
FALSE	FALSE	FALSE	OUTPUT not changed. *
FALSE	TRUE	TRUE	OUTPUT not changed. *

\* If OUTPUT is greater than MAX VALUE the OUTPUT will ramp down to MAX VALUE at RAMP RATE. If OUTPUT is less than MIN VALUE the OUTPUT will ramp up to MIN VALUE at RAMP RATE.

**IMPORTANT:** Do not set MIN VALUE to greater than MAX VALUE, as the resulting value of OUTPUT will be unpredictable.

### MMI Menu Map

1	SETUP PARAMETERS
2	FUNCTION BLOCKS
3	SEQ & REF
4	REFERENCE
	REMOTE SETPOINT
	SPEED TRIM
	MAX SPEED CLAMP
	MIN SPEED CLAMP
	TRIM IN LOCAL
	REMOTE REVERSE
	SPEED DEMAND
	SPEED SETPOINT
	REVERSE
	LOCAL SETPOINT
	LOCAL REVERSE
	COMMS SETPOINT

## REFERENCE

This function block holds all the parameters concerning the generation of the setpoint reference.

The generation of reference setpoint is described in Chapter 4: “Operating the Inverter” - Control Philosophy.

REFERENCE		
	SPEED DEMAND	[255] 0.00 %
	SPEED SETPOINT	[254] 0.00 %
	REVERSE	[256] FALSE
	LOCAL SETPOINT	[247] 0.00 %
	LOCAL REVERSE	[250] FALSE
	COMMS SETPOINT	[269] 0.00 %
0.00 %	[245]	REMOTE SETPOINT
0.00 %	[248]	SPEED TRIM
100.00 %	[252]	MAX SPEED CLAMP
-100.00 %	[253]	MIN SPEED CLAMP
FALSE	[243]	TRIM IN LOCAL
FALSE	[249]	REMOTE REVERSE

## Parameter Descriptions

### REMOTE SETPOINT

*Range: -300.00 to 300.00 %*

This is the target reference that the Inverter will ramp to in remote reference mode (not including trim), direction is taken from REMOTE REVERSE and the sign of REMOTE SETPOINT.

### SPEED TRIM

*Range: -300.00 to 300.00 %*

The trim is added to the ramp output in remote mode (or if TRIM IN LOCAL is TRUE) to form SPEED DEMAND . The trim is typically connected to the output of a PID in a closed loop system.

### MAX SPEED CLAMP

*Range: 0.00 to 100.00 %*

Maximum value for SPEED DEMAND.

### MIN SPEED CLAMP

*Range: -100.00 to 0.00 %*

Minimum value for SPEED DEMAND.

### TRIM IN LOCAL

*Range: FALSE / TRUE*

When TRUE, SPEED TRIM is always added to the ramp output. When FALSE, SPEED TRIM is added only to Remote mode.

### REMOTE REVERSE

*Range: FALSE / TRUE*

Demanded direction when in Remote Reference mode. This is usually connected directly to the Sequencing Logic.

### SPEED DEMAND

*Range: xxx.xh % (h)*

Indicates actual speed demand. This is the input to the frequency controller.

### SPEED SETPOINT

*Range: xxx.xh % (h)*

Indicates target speed. This will be equal to either LOCAL SETPOINT, REMOTE SETPOINT, JOG SETPOINT or COMMS SETPOINT. (Refer to the JOG function block for the JOG SETPOINT parameter).

### REVERSE

*Range: FALSE / TRUE*

Indicates demanded direction. This may not be the actual direction as no account of setpoint sign is taken.

### LOCAL SETPOINT

*Range: 0.00 to 100.00 %*

Indicates the Operator Station setpoint. It is always a positive quantity; saved on power down. Direction is taken from LOCAL REVERSE.

# 6-54 Programming Your Application

## LOCAL REVERSE

Range: FALSE / TRUE

Indicates demanded direction in Local Reference mode, saved on power down.

## COMMS SETPOINT

Range: -300.00 to 300.00 %

This setpoint is the target reference that the Inverter will ramp to in Remote Reference Comms mode (not including trim). The direction is always positive, i.e. forward.

## Functional Description

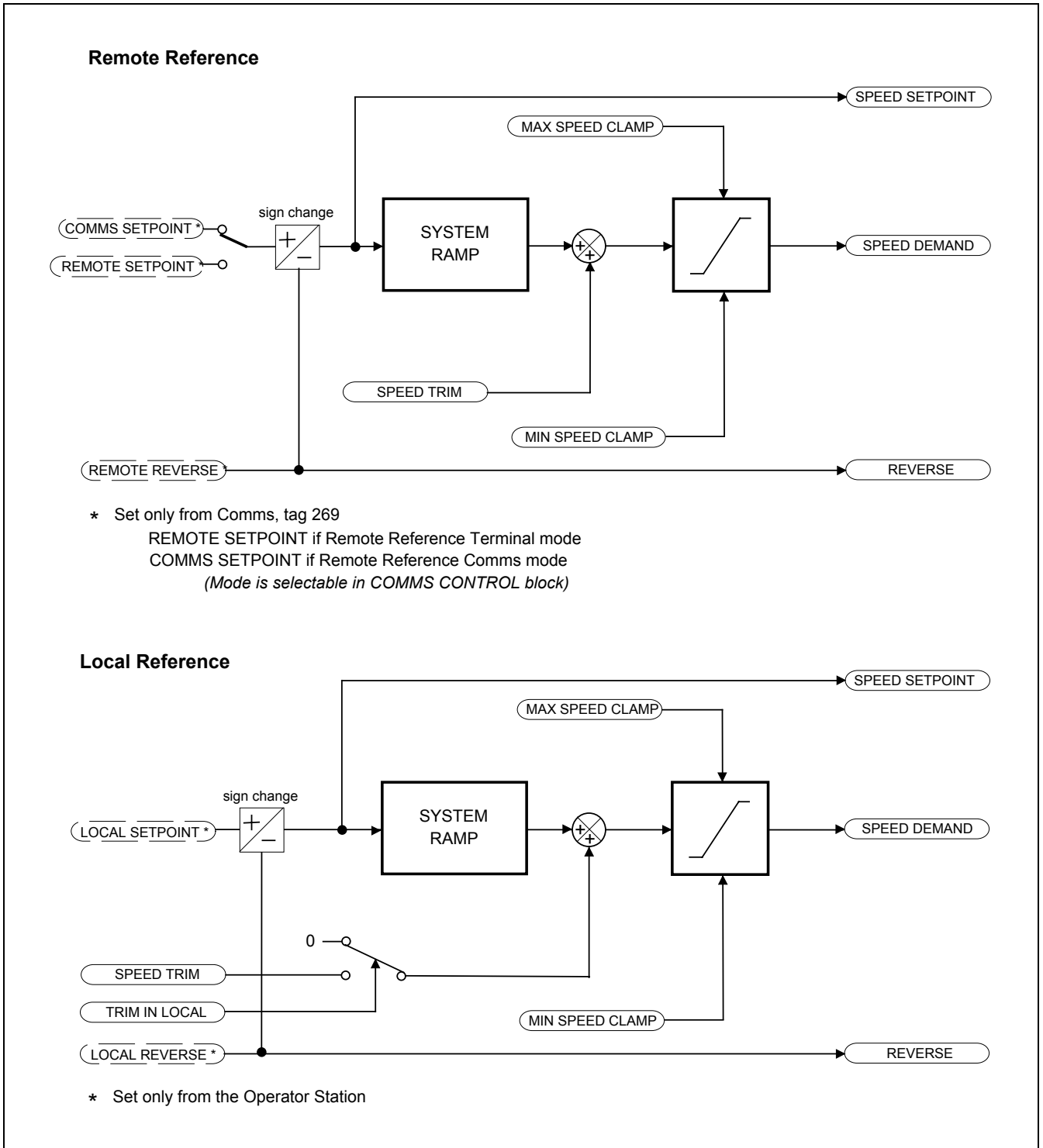

## MMI Menu Map

1	SETUP PARAMETERS
2	FUNCTION BLOCKS
3	SEQ & REF
4	SEQUENCING LOGIC

RUN FWD
RUN REV
/STOP
JOG
DRIVE ENABLE
/FAST STOP
/COAST STOP
REMOTE REVERSE
REM TRIP RESET
TRIP RST BY RUN
POWER UP START
TRIPPED
RUNNING
JOGGING
STOPPING
OUTPUT CONTACTOR
SWITCH ON ENABLE
SWITCHED ON
READY
SYSTEM RESET
MAIN SEQ STATE
REMOTE REV OUT
HEALTHY

## SEQUENCING LOGIC

This function block contains all the parameters relating to the sequencing (start and stop) of the Inverter.

Before the Inverter will respond to the RUN FWD, RUN REV or JOG parameters (cause the Inverter to run or jog), the parameters DRIVE ENABLE, /FAST STOP and /COAST STOP need to be set to TRUE. In addition, the Inverter needs to be healthy (HEALTHY is TRUE). The Inverter will only respond to RUN FWD, RUN REV and JOG if the Inverter is in the Remote Sequencing mode.

If RUN FWD and RUN REV are TRUE, both are ignored and the Inverter will stop.

A detailed description of the sequencer states, as indicated by the MAIN SEQ STATE parameter, is described in Chapter 9. A description of the sequence logic is described in Chapter 4: "Operating the Inverter" - Selecting Local or Remote Control.

SEQUENCING LOGIC		
TRIPPED	[289]	FALSE
RUNNING	[285]	FALSE
JOGGING	[302]	FALSE
STOPPING	[303]	FALSE
OUTPUT CONTACTOR	[286]	FALSE
SWITCH ON ENABLE	[288]	FALSE
SWITCHED ON	[306]	TRUE
READY	[287]	FALSE
SYSTEM RESET	[305]	TRUE
MAIN SEQ STATE	[301]	NOT READY
REMOTE REV OUT	[296]	FALSE
HEALTHY	[274]	FALSE
FALSE	[291]	RUN FWD
FALSE	[292]	RUN REV
FALSE	[293]	/STOP
FALSE	[280]	JOG
TRUE	[276]	DRIVE ENABLE
TRUE	[277]	/FAST STOP
TRUE	[278]	/COAST STOP
FALSE	[294]	REMOTE REVERSE
FALSE	[282]	REM TRIP RESET
TRUE	[290]	TRIP RST BY RUN
FALSE	[283]	POWER UP START

## Parameter Descriptions

### RUN FWD

*Range: FALSE / TRUE*

Setting this parameter to TRUE causes the Inverter to run in the forward direction.

### RUN REV

*Range: FALSE / TRUE*

Setting this parameter to TRUE causes the Inverter to run in the reverse direction.

### /STOP (NOT STOP)

*Range: FALSE / TRUE*

Setting this parameter TRUE will latch the RUN FWD or RUN REV commands. Once latched, they can be reset to FALSE and the Inverter will continue to run. Setting /STOP to FALSE causes the run commands to be un-latched.

### JOG

*Range: FALSE / TRUE*

Setting this parameter TRUE causes the Inverter to run at the speed set by JOG SETPOINT (refer to the JOG function block). Once jogging, setting JOG to FALSE causes the Inverter to ramp to zero.

### DRIVE ENABLE

*Range: FALSE / TRUE*

This provides a means of electronically inhibiting Inverter operation. Whilst running, setting this parameter to FALSE disables the Inverter operation and causes the motor to coast.

### /FAST STOP (NOT FAST STOP)

*Range: FALSE / TRUE*

Whilst running or jogging, setting this parameter to FALSE causes the Inverter to ramp to zero. The rate is set by FAST STOP RATE in the STOP function block. The action of setting /FAST STOP to TRUE is latched. The Inverter cannot be restarted until fast stop is completed.

### /COAST STOP (NOT COAST STOP)

*Range: FALSE / TRUE*

Setting this parameter to FALSE disables the Inverter operation and causes the motor to coast. The action of setting this parameter to TRUE is latched. The Inverter can not be restarted until the coast stop is completed.

## 6-56 Programming Your Application

### **REMOTE REVERSE**

*Range: FALSE / TRUE*

For remote setpoints, setting this parameter TRUE inverts the demanded direction of motor rotation.

### **REM TRIP RESET**

*Range: FALSE / TRUE*

On a transition to TRUE, this input clears latched trips.

### **TRIP RST BY RUN**

*Range: FALSE / TRUE*

This allows the rising edge of run command to clear latched trips.

### **POWER UP START**

*Range: FALSE / TRUE*

If TRUE, this allows the Inverter to go directly to run mode if in remote and a run command is present. If FALSE, a low to high transition of the run command is required.

### **TRIPPED**

*Range: FALSE / TRUE*

Indicates that there is a latched trip present.

### **RUNNING**

*Range: FALSE / TRUE*

Indicates that that the Inverter is in the enabled state.

### **JOGGING**

*Range: FALSE / TRUE*

Indicates that the Inverter is in the JOG mode.

### **STOPPING**

*Range: FALSE / TRUE*

Indicates that the Inverter is stopping.

### **OUTPUT CONTACTOR**

*Range: FALSE / TRUE*

Output to be used to drive an external contactor in the motor output. This contactor is normally closed unless a Trip condition has occurred or the Inverter goes into the re-configuration mode.

### **SWITCH ON ENABLE**

*Range: FALSE / TRUE*

Sometimes referred to as READY TO SWITCH ON, this parameter indicates that the Inverter will accept a run command.

### **SWITCHED ON**

*Range: FALSE / TRUE*

Indicates that the Inverter's power stack is operable and the Inverter will run if enabled.

### **READY**

*Range: FALSE / TRUE*

Output indicating that the Inverter has accepted the run command.

### **SYSTEM RESET**

*Range: FALSE / TRUE*

Output TRUE for a single cycle after the Inverter enters either RUN or JOG mode.

### **MAIN SEQ STATE**

*Range: Enumerated - see below*

This parameter indicates the current sequencing state:

*Enumerated Value : State*

- 0 : NOT READY
- 1 : START DISABLED
- 2 : START ENABLED
- 3 : SWITCHED ON
- 4 : ENABLED
- 5 : F-STOP ACTIVE
- 6 : TRIP ACTIVE
- 7 : TRIPPED

### **REMOTE REV OUT**

*Range: FALSE / TRUE*

This parameter indicates the current state of remote direction and RUN REV. Note - this is the demanded direction, not the actual direction.

### **HEALTHY**

*Range: FALSE / TRUE*

Set FALSE when the Inverter trips, and set TRUE when the run command is removed.

## MMI Menu Map

- 1 SETUP PARAMETERS
- 2 FUNCTION BLOCKS
- 3 MOTOR CONTROL
- 4 SETPOINT SCALE
  - SCALE INPUT
  - MAX SPEED
  - SCALE OUTPUT

## SETPOINT SCALE

This function block simply converts the way the setpoint is expressed from being a percentage of the MAX SPEED to a percentage of LIMIT FREQUENCY (refer to the FLUXING function block).

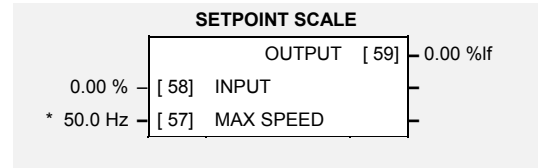

## Parameter Descriptions

### INPUT

Range: -300.00 to 300.00 %

The setpoint delivered by the re-wired function block portion of the Inverter's application.

### MAX SPEED

Range: 0.0 to 480.0 Hz

The physical motor speed equivalent to a setpoint demand of 100.00%. Note that the motor speed in revs per minute, (RPM), is related to the speed in Hz according to the equation:

$$\text{speed in RPM} = \frac{(\text{speed in Hz}) \times 2 \times 60}{\text{number of motor poles}}$$

### OUTPUT

Range: xxx.xx %f

$$\text{Output} = \frac{\text{max speed} \times \text{input}}{\text{limit frequency}}$$

## Functional Description

The setpoint scale block changes the format in which the setpoint is expressed. The function blocks on the input side of this block process the setpoint as a percentage of maximum speed. The function blocks on the output side of this block process the setpoint as a percentage of the LIMIT FREQUENCY.

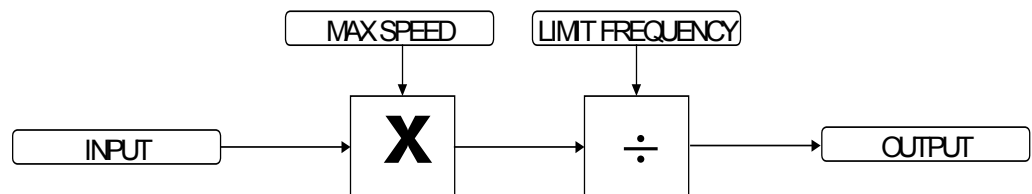

## MMI Menu Map

- 1 SETUP PARAMETERS
- 2 FUNCTION BLOCKS
- 3 SETPOINT FUNCS
- 4 SKIP FREQUENCIES
  - SKIP FREQ INPUT
  - SKIP FREQ BAND 1
  - SKIP FREQUENCY 1
  - SKIP FREQ BAND 2
  - SKIP FREQUENCY 2
  - SKIP FREQ BAND 3
  - SKIP FREQUENCY 3
  - SKIP FREQ BAND 4
  - SKIP FREQUENCY 4
  - SKIP FREQ OUTPUT
  - SKIP FREQ OUTPUT
  - SKIP FREQ INPUT

## SKIP FREQUENCIES

This function block may be used to prevent the Inverter operating at frequencies that cause mechanical resonance in the load.

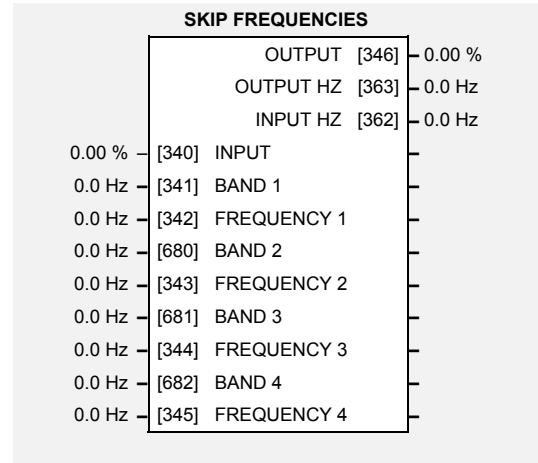

## Parameter Descriptions

### INPUT

The value of the block input in %.

Range: -300.00 to 300.00 %

### BAND 1

The width of each skip band in Hz.

Range: 0.0 to 480.0 Hz

### FREQUENCY 1

This parameter contains the centre frequency of each skip band in Hz.

Range: 0.0 to 480.0 Hz

### BAND 2

The width of each skip band in Hz.

Range: 0.0 to 480.0 Hz

### FREQUENCY 2

This parameter contains the centre frequency of each skip band in Hz.

Range: 0.0 to 480.0 Hz

### BAND 3

The width of each skip band in Hz.

Range: 0.0 to 480.0 Hz

### FREQUENCY 3

This parameter contains the centre frequency of each skip band in Hz.

Range: 0.0 to 480.0 Hz

### BAND 4

The width of each skip band in Hz.

Range: 0.0 to 480.0 Hz

### FREQUENCY 4

This parameter contains the centre frequency of each skip band in Hz.

Range: 0.0 to 480.0 Hz

### OUTPUT

Diagnostic on the output of the function block in %

Range: xxx.xx %

### OUTPUT HZ

Diagnostic on the output of the function block in Hz

Range: xxxx.x Hz

### INPUT HZ

Diagnostic on the input of the function block in Hz

Range: xxxx.x Hz

## Functional Description

Four programmable skip frequencies are available to avoid resonances within the mechanical system. Enter the value of frequency that causes the resonance using the "FREQUENCY" parameter and then programme the width of the skip band using its "BAND" parameter. The Inverter will then avoid sustained operation within the forbidden band as shown in the diagram. The skip frequencies are symmetrical and thus work in forward and reverse.

**Note:** Setting the FREQUENCY to 0 disables the corresponding band.  
Setting the BAND to 0 causes the value of BAND 1 to be used for this band.

The behaviour of this function block is illustrated below.

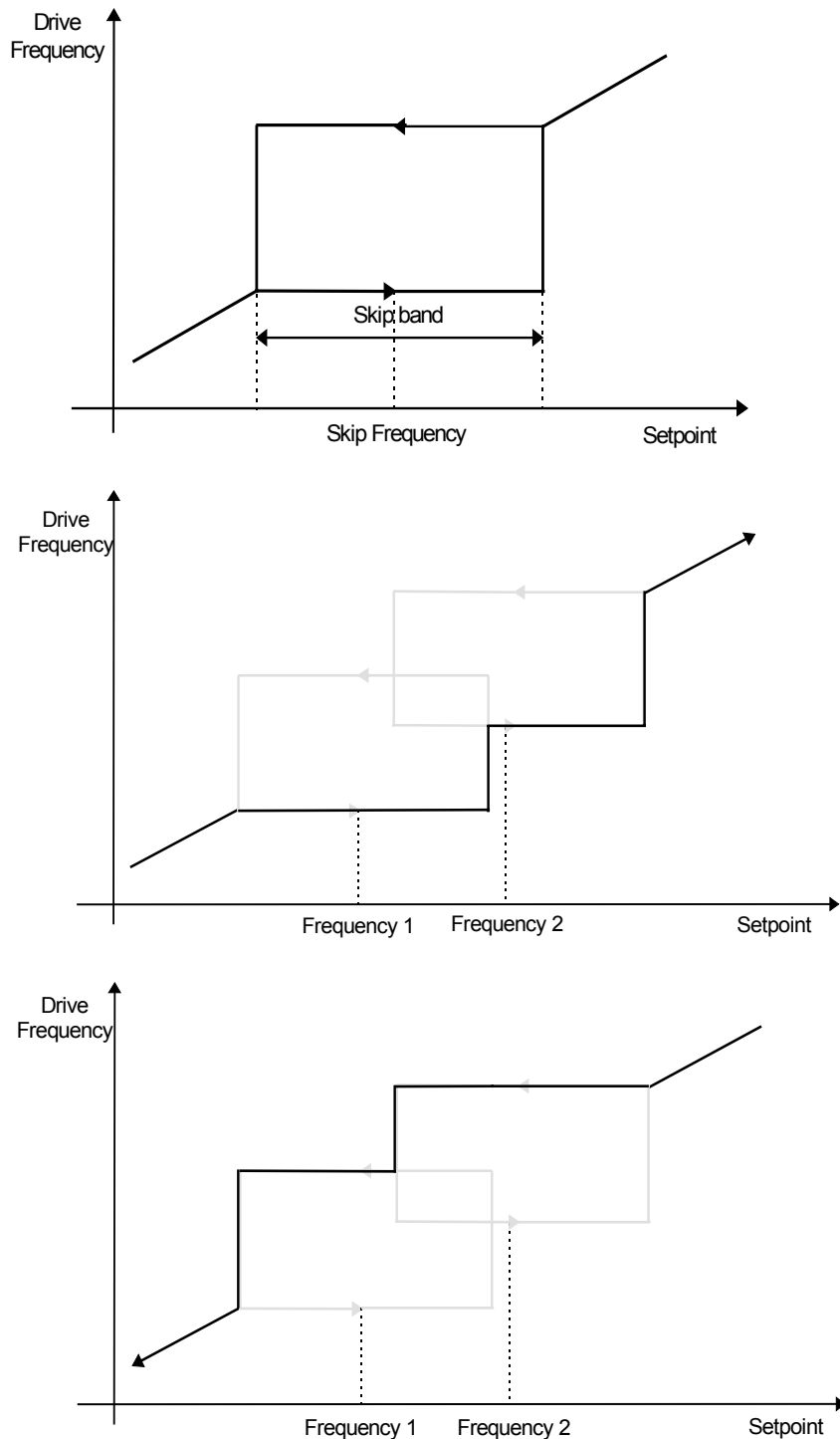

# 6-60 Programming Your Application

## MMI Menu Map

- 1 SETUP PARAMETERS
- 2 FUNCTION BLOCKS
- 3 MOTOR CONTROL
- 4 SLEW RATE LIMIT
  - SLEW ENABLE
  - SLEW ACCEL LIMIT
  - SLEW DECEL LIMIT

## SLEW RATE LIMIT

This function block prevents over-current and over-voltage faults occurring due to a rapidly changing setpoint.

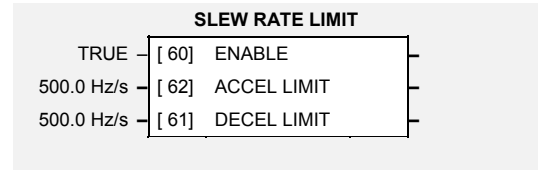

## Parameter Descriptions

### ENABLE

Range: FALSE / TRUE

When this parameter is FALSE, this function block is disabled and the setpoint is unaffected by this function block.

### ACCEL LIMIT

Range: 12.0 to 1200.0 Hz/s

The maximum rate at which the setpoint may accelerate away from zero.

### DECEL LIMIT

Range: 12.0 to 1200.0 Hz/s

The maximum rate at which the setpoint may decelerate towards zero.

## Functional Description

The slew rate limits block obtains the setpoint from the output of the application, correctly scaled by the setpoint scale block. The rate of change limits are then applied and the setpoint is then passed on for future processing by the current limit block.

When the braking block determines that the internal dc link voltage is too high it issues a Hold signal. This causes the slew rate limits block to hold the setpoint at its current value. This typically lasts for only 1ms, time for the excess energy to be dumped into the braking resistor.

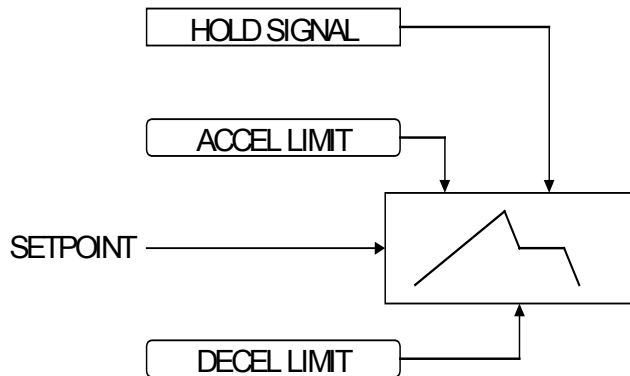

## MMI Menu Map

- 1 SETUP PARAMETERS
- 2 FUNCTION BLOCKS
- 3 MOTOR CONTROL
- 4 SLIP COMP
  - SLIP ENABLE
  - NAMEPLATE RPM
  - MOTOR POLES
  - SLIP MOTOR LIMIT
  - SLIP REGEN LIMIT
  - SLIP ACTIVE

## SLIP COMP

The slip compensation function block allows the Inverter to maintain motor speed in the presence of load disturbances.

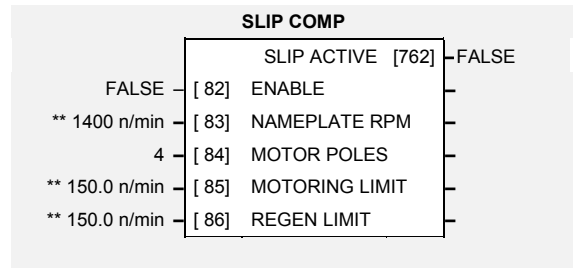

## Parameter Descriptions

### ENABLE

Range: FALSE / TRUE

For the slip compensation to be operational this must be TRUE.

### NAMEPLATE RPM

Range: 0 to 28800 n/min

This is the rated speed of the motor at rated load.

### MOTOR POLES

Range: Enumerated - see below

The number of motor poles. The values that this parameter may take are:

Enumerated Value : Number of poles

- 0 : 2
- 1 : 4
- 2 : 6
- 3 : 8
- 4 : 10
- 5 : 12

### MOTORING LIMIT

Range: 0.0 to 600.0 n/min

The maximum trim that will be produced by the slip compensation block when the motor is driving the load (motoring).

### REGEN LIMIT

Range: 0.0 to 600.0 n/min

The maximum trim that will be produced by the slip compensation block when the motor is being driven by the load, (regenerating).

### SLIP ACTIVE

Range: FALSE / TRUE

Indicates when Slip Compensation is being applied.

## Functional Description

Based on the rated speed, the no load speed and the rated load of the motor, the slip compensation block adjusts the demand frequency to compensate for any speed slippage resulting from the load.

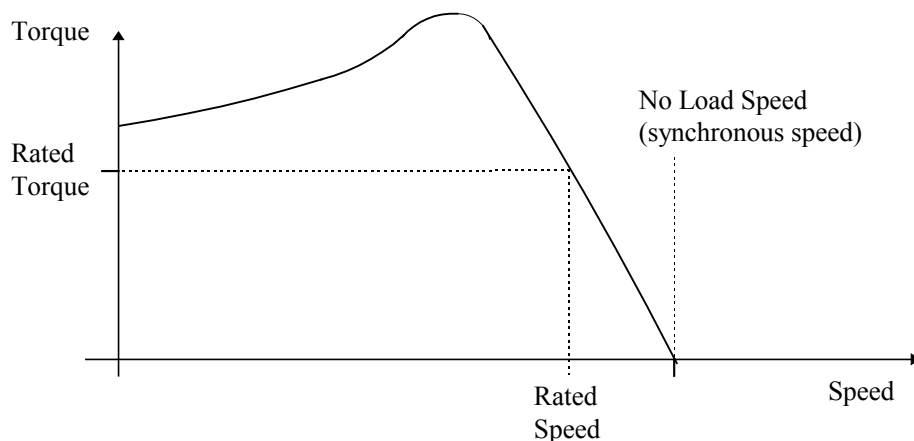

# 6-62 Programming Your Application

## MMI Menu Map

- 1 SETUP PARAMETERS
- 2 FUNCTION BLOCKS
- 3 MOTOR CONTROL
- 4 STABILISATION
  - STB ENABLE

## STABILISATION

Enabling this function alleviates the problem of unstable running in induction motors. This can be experienced at approximately half full speed, and under low load conditions.

## Parameter Descriptions

### ENABLE

Enables (or disables) the stabilisation function.

### STABILISATION

TRUE - [128] ENABLE -

*Range: FALSE / TRUE*

## MMI Menu Map

- 1 SETUP PARAMETERS
- 2 FUNCTION BLOCKS
- 3 TRIPS
- 4 STALL TRIP
  - STALL LIMIT
  - STALL TIME

## STALL TRIP

The function block protects the motor from damage that may be caused by continuous operation beyond specification.

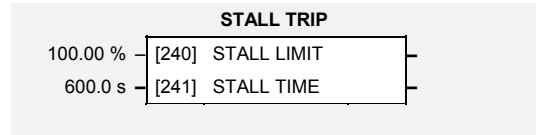

## Parameter Descriptions

### STALL LIMIT

*Range: 50.00 to 150.00 %*

The load limit beyond which the stall trip monitoring becomes active.

### STALL TIME

*Range: 0.1 to 3000.0 s*

The time after which a stall condition will cause a trip.

## Functional Description

If the estimated load exceeds the STALL LIMIT for a time greater than STALL TIME then the stall trip will become active. The timer is reset whenever the estimated load is less than the STALL LIMIT.

Refer to Chapter 7 for a description of the trips supported by the Inverter.

## MMI Menu Map

1	SETUP PARAMETERS
2	FUNCTION BLOCKS
3	SEQ & REF
4	STOP
	RUN STOP MODE
	STOP RATE
	STOP ZERO SPEED
	STOP DELAY
	FAST STOP MODE
	FAST STOP LIMIT
	FAST STOP RATE
	FINAL STOP RATE

## STOP

This function block holds all the parameters concerning the stopping method of the Inverter.

The stopping methods of the Inverter are described in more detail in Chapter 4: "Operating the Inverter" - Starting and Stopping Methods..

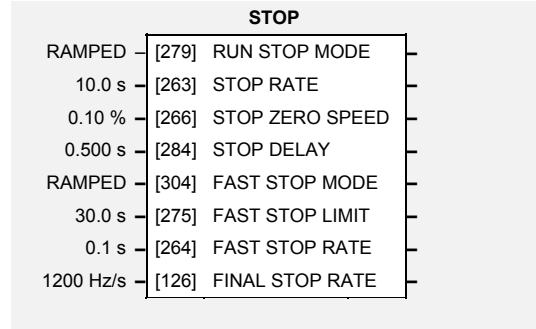

## Parameter Descriptions

### RUN STOP MODE

*Range: Enumerated - see below*

Selects stopping mode that the controller will use once the run command has been removed. The choices are:

*Enumerated Value : Stopping Mode*

0 : RAMPED

1 : COAST

2 : DC INJECTION

When RAMPED is selected, the Inverter will decelerate using the system ramp deceleration time, provided it is non zero. When COAST is selected, the motor will free-wheel. When DC INJECTION is selected, the motor is stopped by applying dc current.

### STOP RATE

*Range: 0.0 to 600.0 s*

Rate at which the demand is ramped to zero after the ramp has been quenched.

### STOP ZERO SPEED

*Range: 0.00 to 100.00 %*

Threshold for zero speed detection used by stop sequences.

### STOP DELAY

*Range: 0.000 to 30.000 s*

Sets the time at which the Inverter holds zero speed before quenching after a normal stop or a jog stop. This may be particularly useful if a mechanical brake requires time to operate at zero speed, or for jogging a machine to position.

### FAST STOP MODE

*Range: Enumerated - see below*

Selects stopping mode used during a fast stop, two options ramped or coast.

*Enumerated Value : Stopping Mode*

0 : RAMPED

1 : COAST

### FAST STOP LIMIT

*Range: 0.0 to 3000.0 s*

Maximum time that the Inverter will try to Fast Stop, before quenching.

### FAST STOP RATE

*Range: 0.0 to 600.0 s*

Rate at which the SPEED DEMAND is ramped to zero (see REFERENCE function block)

### FINAL STOP RATE

*Range: 12 to 4800 Hz/s*

Rate at which any internally generated setpoint trims are removed. For example, the trim due to the slip compensation block.

## MMI Menu Map

- 1 SETUP PARAMETERS
- 2 FUNCTION BLOCKS
- 3 SERIAL LINKS
- 4 SYSTEM PORT (P3)
  - GROUP ID (GID)
  - UNIT ID (UID)

## SYSTEM PORT (P3)

The unisolated RS232 programming port allows for connection to the Operator Station, or to a personal computer for drive configuration and storage of parameters. The parameters below are used to identify the Inverter to the controlling software.

The port uses the SSD Drives standard EI BISYNCH ASCII protocol.

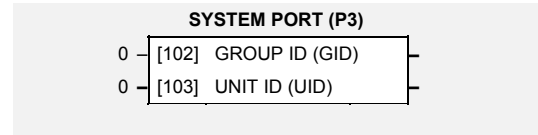

## Parameter Descriptions

### GROUP ID (GID)

*Range: 0 to 9*

The SSD Drives protocol group identity address.

### UNIT ID (UID)

*Range: 0 to 15*

The SSD Drives protocol unit identity address

## Functional Description

The unit will always respond to GID = 0 and UID = 0, as this is the “broadcast” address used by the Operator Station.

**Note:** *The Technology Option uses a different port and address. It does not respond to the “broadcast” address.*

## MMI Menu Map

1	SETUP PARAMETERS
2	FUNCTION BLOCKS
3	SEQ & REF
4	SYSTEM RAMP
	RAMP TYPE
	RAMP ACCEL RATE
	RAMP DECEL RATE
	RAMP SYM RATE
	RAMP SYM MODE
	RAMP HOLD
	SRAMP CONTINUOUS
	SRAMP ACCEL
	SRAMP DECEL
	SRAMP JERK 1
	SRAMP JERK 2
	SRAMP JERK 3
	SRAMP JERK 4
	RAMPING

## SYSTEM RAMP

This function block forms part of the reference generation. It provides the facility to control the rate at which the Inverter will respond to a changing setpoint demand.

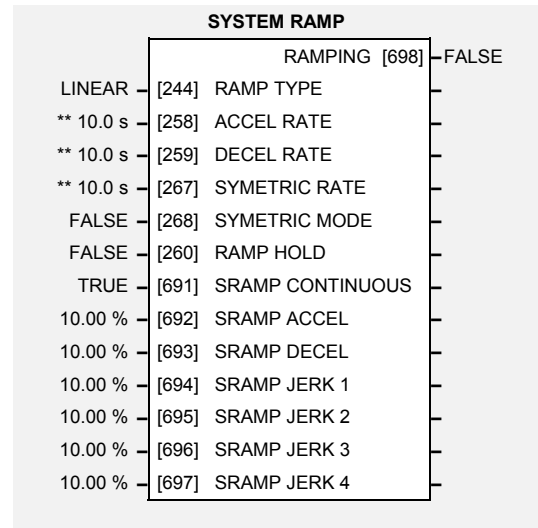

## Parameter Descriptions

### RAMP TYPE

Select the ramp type:

Range: Enumerated - see below

Enumerated Value : Ramp Type

- 0 : LINEAR
- 1 : S

### ACCEL RATE

The time that the Inverter will take to ramp the setpoint, from 0.00% to 100.00%.

Range: 0.0 to 600.0 s

### DECEL RATE

The time that the Inverter will take to ramp from the setpoint, from 100.00% to 0.00%.

Range: 0.0 to 600.0 s

### SYMETRIC RATE

The time that the Inverter will take to ramp from 0.00% to 100.00% and from 100.00% to 0.00% when SYMETRIC MODE is TRUE.

Range: 0.0 to 600.0 s

### SYMETRIC MODE

Select whether to use the ACCEL RATE and DECEL RATE pair of ramp rates, or to use the SYMETRIC RATE parameter to define the ramp rate for the Inverter.

Range: FALSE / TRUE

### RAMP HOLD

When TRUE the output of the ramp is held at its last value.

Range: FALSE / TRUE

### SRAMP CONTINUOUS

When TRUE and the S ramp is selected, forces a smooth transition if the speed setpoint is changed when ramping. The curve is controlled by the SRAMP ACCEL and SRAMP JERK 1 to SRAMP JERK 4 parameters. When FALSE, there is an immediate transition from the old curve to the new curve.

Range: FALSE / TRUE

### SRAMP ACCEL

Sets the acceleration rate in units of percent per second<sup>2</sup>, i.e. if the full speed of the machine is 1.25m/s then the acceleration will be:

Range: 0.00 to 100.00 %

$$1.25 \times 75.00\% = 0.9375\text{m/s}^2$$

### SRAMP DECEL

This functions in the same way as SRAMP ACCEL above.

Range: 0.00 to 100.00 %

**SRAMP JERK 1**

*Range: 0.00 to 100.00 %*

Rate of change of acceleration for the first segment of the curve in units per second<sup>3</sup>, i.e. if the full speed of the machine is 1.25m/s then the acceleration will be:

$$1.25 \times 50.00\% = 0.625\text{m/s}^3$$

**SRAMP JERK 2**

*Range: 0.00 to 100.00 %*

Rate of change of acceleration in units of percent per second<sup>3</sup> for segment 2.

**SRAMP JERK 3**

*Range: 0.00 to 100.00 %*

Rate of change of acceleration in units of percent per second<sup>3</sup> for segment 3.

**SRAMP JERK 4**

*Range: 0.00 to 100.00 %*

Rate of change of acceleration in units of percent per second<sup>3</sup> for segment 4.

**RAMPING**

*Range: FALSE / TRUE*

Set TRUE when ramping.

**Functional Description**

Chapter 4: “Operating the Inverter” - Starting and Stopping Methods, describes the use of the system ramp.

The ramp output takes the form shown below.

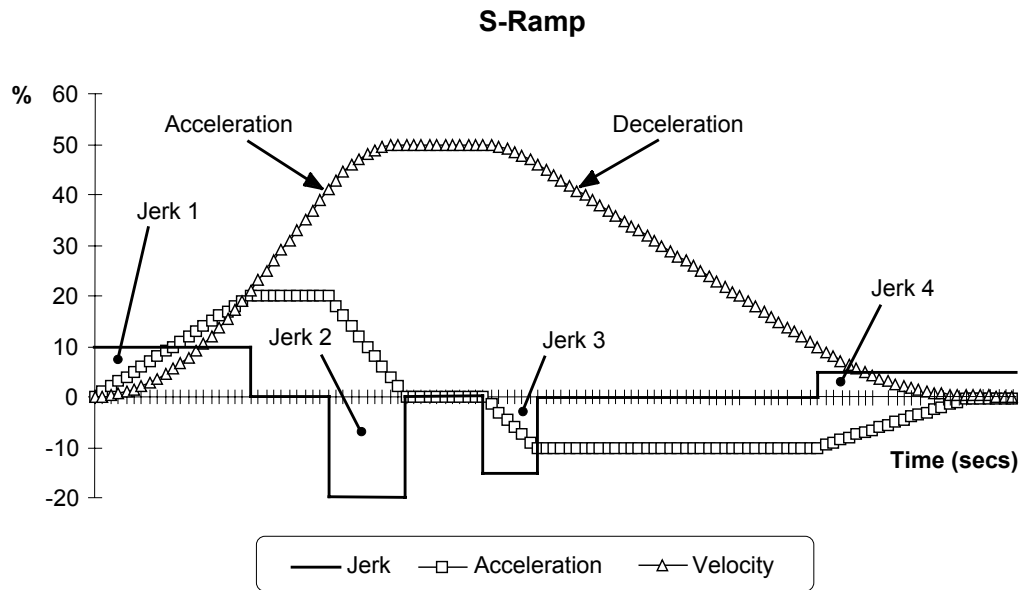

## MMI Menu Map

- 1 SETUP PARAMETERS
- 2 FUNCTION BLOCKS
- 3 SERIAL LINKS
- 4 TEC OPTION
  - TEC OPTION TYPE
  - TEC OPTION IN 1
  - TEC OPTION IN 2
  - TEC OPTION IN 3
  - TEC OPTION IN 4
  - TEC OPTION IN 5
  - TEC OPTION FAULT
  - TEC OPTION VER
  - TEC OPTION OUT 1
  - TEC OPTION OUT 2

## TEC OPTION

This function block is used to configure the inputs and outputs of the various Technology Options that can be fitted.

The Technology Option provides a communications interface for external control of the Inverter.

If a Technology Option is present when defaults are loaded, the TYPE parameter is automatically set. The parameter names change when the selection for the TYPE parameter matches the Technology Option fitted.

Refer to the appropriate Technology Option Technical Manual supplied with the option for further details.

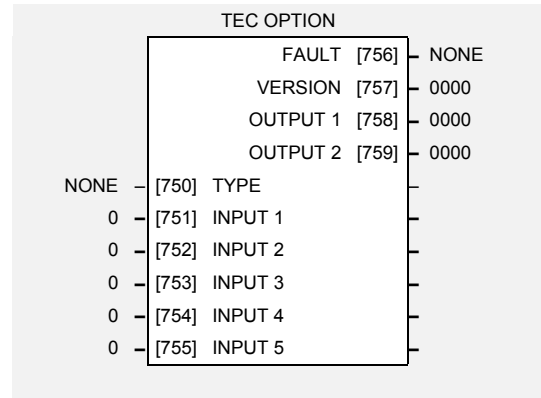

## Parameter Descriptions

### TYPE

Range: Enumerated - see below

Selects the type of Technology Option.

Enumerated Value : Technology Option

- 0 : NONE
- 1 : RS485
- 2 : PROFIBUS DP
- 3 : LINK
- 4 : DEVICENET
- 5 : CANOPEN
- 6 : LONWORKS
- 7 : TYPE 7

### INPUT 1 to INPUT 5

Range: -32768 to 32767

The use of these input parameters depends on the type of Technology Option fitted. Refer to the Technology Option Technical Manual.

### FAULT

Range: Enumerated - see below

The fault state of the Technology Option.

Enumerated Value : Fault State

- 0 : NONE
- 1 : PARAMETER
- 2 : TYPE MISMATCH
- 3 : SELF TEST
- 4 : HARDWARE
- 5 : MISSING

### VERSION

Range: 0000 to FFFF

The version of the Technology Option. If no option is fitted then the version is reset to zero.

### OUTPUT 1 and OUTPUT 2

Range: 0000 to FFFF

The use of these output parameters depends on the type of Technology Option fitted. Refer to the Technology Option Technical Manual.

**MMI Menu Map**

1	SETUP PARAMETERS
2	FUNCTION BLOCKS
3	TRIPS
4	TRIPS HISTORY
	TRIP 1 (NEWEST)
	TRIP 2
	TRIP 3
	TRIP 4
	TRIP 5
	TRIP 6
	TRIP 7
	TRIP 8
	TRIP 9
	TRIP 10 (OLDEST)

**TRIPS HISTORY**

This function block records the last ten trips that caused the Inverter to stop.

To do this, it stores the value of the FIRST TRIP parameter, tag number 6, taken from the TRIPS STATUS function block.

TRIPS HISTORY		
TRIP 1 (NEWEST	[500]	NO TRIP
TRIP 2	[501]	NO TRIP
TRIP 3	[502]	NO TRIP
TRIP 4	[503]	NO TRIP
TRIP 5	[504]	NO TRIP
TRIP 6	[505]	NO TRIP
TRIP 7	[506]	NO TRIP
TRIP 8	[507]	NO TRIP
TRIP 9	[508]	NO TRIP
TRIP 10 (OLDEST	[509]	NO TRIP

**Parameter Descriptions**

**TRIP 1 (NEWEST)**

*Range: Enumerated*

Records the most recent trip that caused the Inverter to stop. The values that this (and the parameters below) may take are the same as tag number 6, FIRST TRIP, detailed in the TRIPS STATUS function block.

**TRIP 2**

*Range: As above*

Records the second most recent trip that caused the Inverter to stop.

**TRIP 3**

*Range: As above*

Records the third most recent trip that caused the Inverter to stop.

**TRIP 4**

*Range: As above*

Records the fourth most recent trip that caused the Inverter to stop.

**TRIP 5**

*Range: As above*

Records the fifth most recent trip that caused the Inverter to stop.

**TRIP 6**

*Range: As above*

Records the sixth most recent trip that caused the Inverter to stop.

**TRIP 7**

*Range: As above*

Records the seventh most recent trip that caused the Inverter to stop.

**TRIP 8**

*Range: As above*

Records the eighth most recent trip that caused the Inverter to stop.

**TRIP 9**

*Range: As above*

Records the ninth most recent trip that caused the Inverter to stop.

**TRIP 10 (OLDEST)**

*Range: As above*

Records the tenth most recent trip that caused the Inverter to stop.

**Functional Description**

This function block provides a view of the ten most recent trips that caused the Inverter to stop. Every time a new trip occurs this is entered as TRIP 1 (NEWEST and the other recorded trips are moved down. If more than ten trips have occurred since the Inverter was configured then only the ten most recent trips will be available for inspection.

These parameters are preserved through a power failure.

## MMI Menu Map

- 1 SETUP PARAMETERS
- 2 FUNCTION BLOCKS
- 3 TRIPS
- 4 TRIPS STATUS
  - DISABLED TRIPS
  - DISABLED TRIPS+
  - INVERT THERMIST
  - ACTIVE TRIPS
  - ACTIVE TRIPS+
  - TRIP WARNINGS
  - TRIP WARNINGS+
  - FIRST TRIP

or

## MMI Menu Map

- 1 TRIPS STATUS
  - DISABLED TRIPS
  - DISABLED TRIPS+
  - INVERT THERMIST
  - ACTIVE TRIPS
  - ACTIVE TRIPS+
  - TRIP WARNINGS
  - TRIP WARNINGS+
  - FIRST TRIP

## TRIPS STATUS

The Inverter supports advanced and flexible trip logic to support monitoring of the Inverter itself, the motor and the load. This function block provides a view into the current trip condition(s) and allows some trips to be disabled.

TRIPS STATUS		
ACTIVE TRIPS	[ 4]	0000
ACTIVE TRIPS+	[740]	0000
WARNINGS	[ 5]	0000
WARNINGS+	[741]	0000
FIRST TRIP	[ 6]	NO TRIP
0600	[231]	DISABLED TRIPS
0000	[742]	DISABLED TRIPS+
FALSE	[760]	INVERT THERMIST

## Parameter Descriptions

### DISABLED TRIPS and DISABLED TRIPS+

Range: 0000 to FFFF

Indicates which trips have been disabled. Not all trips may be disabled, the DISABLED TRIPS mask is ignored for trips that cannot be disabled. See below for which trips may be disabled and how this parameter is formed.

### INVERT THERMIST

Range: FALSE / TRUE

Inverts the thermistor input.

### ACTIVE TRIPS and ACTIVE TRIPS+

Range: 0000 to FFFF

Indicates which trips are currently active. These parameters are a coded representation of the trip status. See below for a description of how this parameter is formed.

### WARNINGS and WARNINGS+

Range: 0000 to FFFF

Indicates which conditions are likely to cause a trip. These parameters are a coded representation of the warning status. See below for a description of how this parameter is formed.

### FIRST TRIP

Range: Enumerated - see below

From when a trip occurs until that trip is reset, this parameter indicates the trip source. When several trips have occurred, this parameter indicates the first one that was detected.

Enumerated Value : First Trip

- 0 : NO TRIP
- 1 : LINK OVERVOLTS
- 2 : LINK UNDERVOLT
- 3 : OVERCURRENT
- 4 : HEATSINK TEMP
- 5 : EXTERNAL TRIP
- 6 : INPUT 1 BREAK
- 7 : INPUT 2 BREAK
- 8 : MOTOR STALLED
- 9 : I\*T TRIP
- 10 : BRAKE RESISTOR
- 11 : BRAKE SWITCH
- 12 : OP STATION
- 13 : LOST COMMS
- 14 :
- 15 :
- 16 :
- 17 : MOTOR TEMP
- 18 : CURRENT LIMIT
- 19 : SHORT CIRCUIT
- 20 : 24V FAILURE
- 21 : LOW SPEED I
- 22 : PHASE FAIL

## Functional Description

The table below shows the possible parameter values for FIRST TRIP, and the TRIPS HISTORY function block. Also shown is whether or not the trip may be disabled.

Trip name	Enumerated value	May be Disabled
NO TRIP	0	N/A
LINK OVERVOLTS	1	No
LINK UNDERVOLT	2	No
OVERCURRENT	3	No
HEATSINK TEMP	4	No
EXTERNAL TRIP	5	Yes
INPUT 1 BREAK	6	Yes
INPUT 2 BREAK	7	Yes
MOTOR STALLED	8	Yes
I*T TRIP	9	No
BRAKE RESISTOR	10	Yes
BRAKE SWITCH	11	Yes
OP STATION	12	Yes
LOST COMMS	13	Yes
	14	
	15	
	16	
MOTOR TEMP	17	Yes
CURRENT LIMIT	18	No
SHORT CIRCUIT	19	No
24V FAILURE	20	Yes
LOW SPEED I	21	No
PHASE FAIL	22	Yes

## Hexadecimal Representation of Trips

The ACTIVE TRIPS, WARNINGS and DISABLED TRIPS parameters use a four digit hexadecimal number to identify individual trips. Each trip has a unique corresponding number. Refer to “Hexadecimal Representation of Trips” at the beginning of this Chapter.

# 6-72 Programming Your Application

## MMI Menu Map

- 1 SETUP PARAMETERS
- 2 FUNCTION BLOCKS
- 3 MOTOR CONTROL
- 4 UNDERLAP COMP
  - ULC ENABLE

## UNDERLAP COMP

The underlap compensation function block ensures sinusoidal motor current at low motor speeds.

This significantly reduces `cogging` (rough/pulsating motor rotation) at low speeds. Underlap compensation is especially desirable in lift or hoist applications.

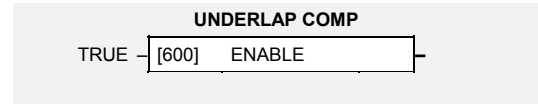

## Parameter Descriptions

### ENABLE

Range: FALSE / TRUE

Enables underlap compensation when set to TRUE.

## Functional Description

Underlap is the bridge switching delay required for correct operation of the Inverter power electronic output stage. The delay causes errors in the Inverter output voltage leading to non-sinusoidal motor currents at low motor speeds. The result is motor cogging, and a loss of motor torque at low speeds.

Underlap compensation removes underlap errors, and provides consistent motor operation regardless of motor speed.

## VALUE FUNCTION

The value function blocks can be configured to perform one of a number of functions upon a fixed number of inputs.

**MMI Menu Map**

1	SETUP PARAMETERS
2	FUNCTION BLOCKS
3	MISCELLANEOUS
4	VALUE FUNCTIONS
5	VALUE FUNC 1
5	VALUE FUNC 2
5	VALUE FUNC 3
5	VALUE FUNC 4
5	VALUE FUNC 5
5	VALUE FUNC 6
5	VALUE FUNC 7
5	VALUE FUNC 8
5	VALUE FUNC 9
5	VALUE FUNC 10
	INPUT A
	INPUT B
	INPUT C
	TYPE
	OUTPUT

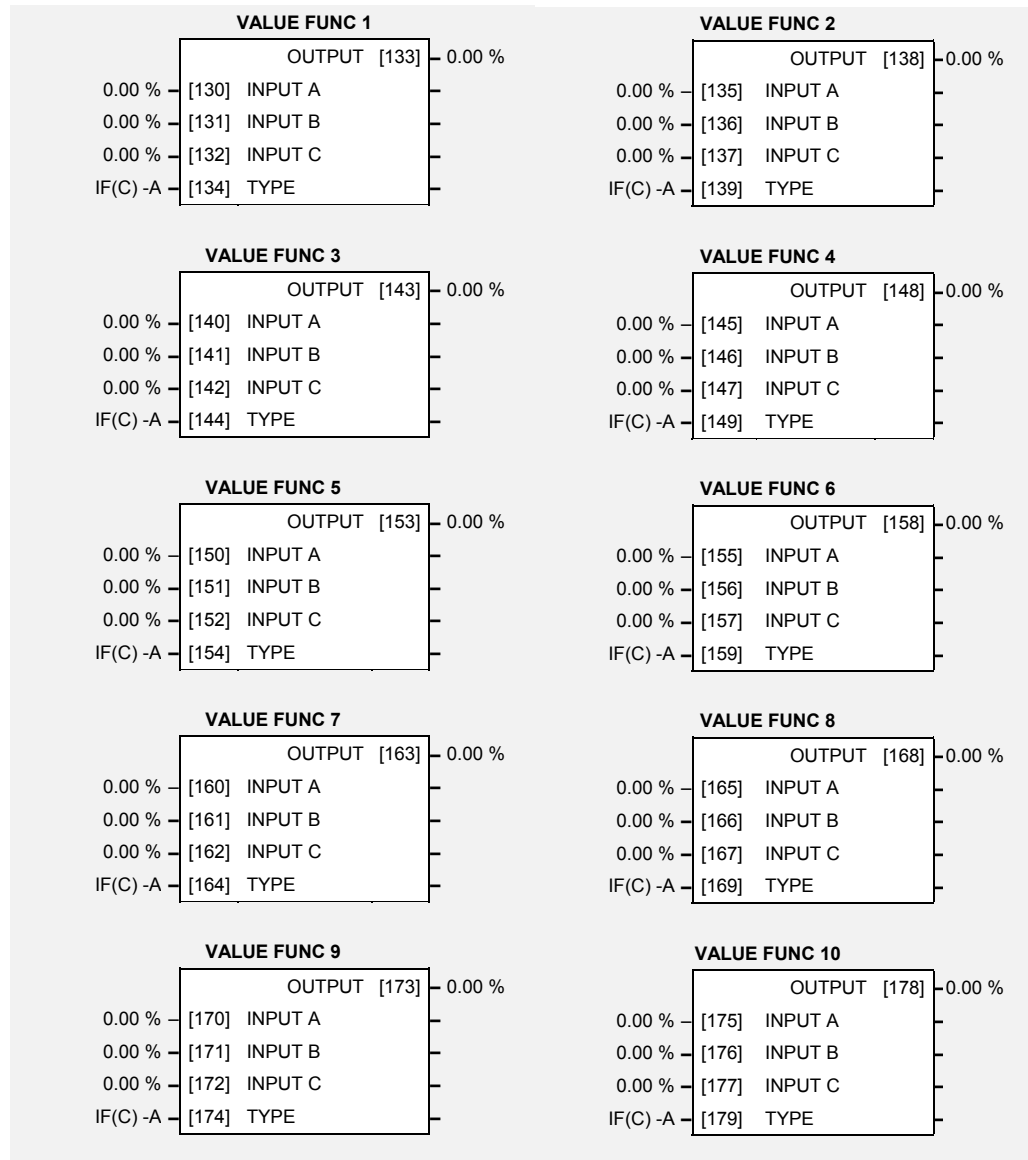

If inputs and outputs are time values, divide the time in seconds by a factor of ten, i.e. 11.3 seconds = 1.13%.

Conversely, outputs are multiplied by a factor of ten to obtain their value in seconds.

Boolean inputs or outputs are FALSE if zero, and TRUE if non-zero.

## Parameter Descriptions

**INPUT A** *Range: -300.00 to 300.00 %*  
 General purpose input.

**INPUT B** *Range: -300.00 to 300.00 %*  
 General purpose input.

**INPUT C** *Range: -300.00 to 300.00 %*  
 General purpose input.

**TYPE** *Range: Enumerated - see below*

The operation to be performed on the three inputs to produce the output value.

*Enumerated Value : Type*

- 0 : IF(C) -A
- 1 : ABS(A+B+C)
- 2 : SWITCH(A,B)
- 3 : (A\*B)/C
- 4 : A+B+C
- 5 : A-B-C
- 6 : B<=A<=C
- 7 : A>B+/-C
- 8 : A>=B
- 9 : ABS(A)>B+/-C
- 10 : ABS(A)>=B
- 11 : A(1+B)
- 12 : IF(C) HOLD(A)
- 13 : BINARY DECODE
- 14 : ON DELAY
- 15 : OFF DELAY
- 16 : TIMER
- 17 : MINIMUM PULSE
- 18 : PULSE TRAIN
- 19 : WINDOW
- 20 : UP/DWN COUNTER
- 21 : (A\*B)/C ROUND
- 22 : WINDOW NO HYST

**OUTPUT** *Range: xxx.xx %*  
 The result of performing the selected operation on the inputs.

## Functional Description

OUTPUT is generated from the inputs according to the operation type selected. The output is always limited to be within the range -300.00% to +300.00%.

Operation	Description
IF(C) -A	If INPUT C is not zero the OUTPUT is minus INPUT A, otherwise the OUTPUT is the same as INPUT A.
ABS(A+B+C)	The OUTPUT is set to the absolute value of INPUT A + INPUT B + INPUT C.
SWITCH(A,B)	<div style="display: flex; align-items: center;"> <div style="margin-right: 20px;"> </div> <div> <p>If INPUT C is zero the OUTPUT is set to INPUT A, otherwise the output is set to INPUT B</p> </div> </div>
(A*B)/C	The OUTPUT is set to (INPUT A * INPUT B) / (INPUT C). The algorithm compensates for the remainder term.

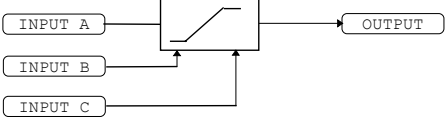
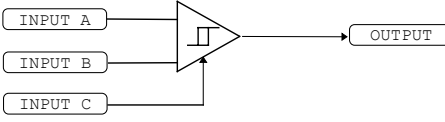
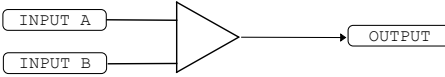
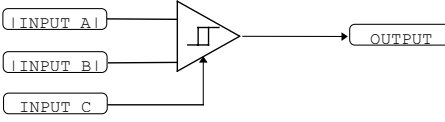
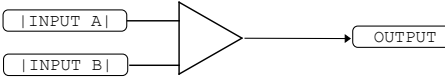
Operation	Description																																				
$A+B+C$	The OUTPUT is set to (INPUT A + INPUT B + INPUT C).																																				
$A-B-C$	The OUTPUT is set to (INPUT A - INPUT B - INPUT C).																																				
$B \leq A \leq C$	<div style="display: flex; align-items: center; gap: 20px;">  <div style="font-size: small; padding-left: 10px;"> <p>The OUTPUT is set to the value of INPUT A, limited to between a maximum value of INPUT C and a minimum value of INPUT B. If INPUT B is greater than INPUT C the output is undefined.</p> </div> </div>																																				
$A > B +/- C$	<div style="display: flex; align-items: center; gap: 20px;">  <div style="font-size: small; padding-left: 10px;"> <p>The OUTPUT is TRUE if INPUT A is greater than INPUT B + INPUT C. The OUTPUT is FALSE if INPUT A is less than INPUT B - INPUT C.</p> <p>Otherwise the OUTPUT is unchanged. In this way the block acts as a simple comparator with a comparison level of INPUT B and a hysteresis band equal to +/- INPUT C.</p> </div> </div>																																				
$A \geq B$	<div style="display: flex; align-items: center; gap: 20px;">  <div style="font-size: small; padding-left: 10px;"> <p>The OUTPUT is TRUE if INPUT A is greater than or equal to INPUT B, otherwise the OUTPUT is FALSE.</p> </div> </div>																																				
$ABS(A) > ABS(B) +/- C$	<div style="display: flex; align-items: center; gap: 20px;">  <div style="font-size: small; padding-left: 10px;"> <p>The OUTPUT is TRUE if the magnitude of INPUT A is greater than or equal to the magnitude of INPUT B - INPUT C.</p> <p>The OUTPUT is FALSE if the magnitude of INPUT A is less than the magnitude of INPUT B - INPUT C. Otherwise the OUTPUT is unchanged. In this way the block acts as a magnitude comparator with a comparison level of INPUT B and a hysteresis band equal to +/- INPUT C.</p> </div> </div>																																				
$ABS(A) > = ABS(B)$	<div style="display: flex; align-items: center; gap: 20px;">  <div style="font-size: small; padding-left: 10px;"> <p>The OUTPUT is TRUE if the magnitude of INPUT A is greater than or equal to the magnitude of INPUT B, otherwise the OUTPUT is FALSE.</p> </div> </div>																																				
$A(1+B)$	The OUTPUT is set to $INPUT A + (INPUT A * INPUT B / 100.00)$ .																																				
IF(C) HOLD A	<p>If INPUT C is zero, the OUTPUT is set to INPUT A, otherwise the OUTPUT is unchanged.</p> <p>On powering up the drive, the output will be pre-loaded with the last saved value of input B.</p>																																				
BINARY DECODE	<p>The OUTPUT is set according to which of the INPUTs are non-zero.</p> <table border="1" style="width: 100%; border-collapse: collapse; font-size: x-small;"> <thead> <tr> <th>INPUT C</th> <th>INPUT B</th> <th>INPUT A</th> <th>OUTPUT</th> </tr> </thead> <tbody> <tr><td>0</td><td>0</td><td>0</td><td>0.00</td></tr> <tr><td>0</td><td>0</td><td>≠0</td><td>0.01</td></tr> <tr><td>0</td><td>≠0</td><td>0</td><td>0.02</td></tr> <tr><td>0</td><td>≠0</td><td>≠0</td><td>0.03</td></tr> <tr><td>≠0</td><td>0</td><td>0</td><td>0.04</td></tr> <tr><td>≠0</td><td>0</td><td>≠0</td><td>0.05</td></tr> <tr><td>≠0</td><td>≠0</td><td>0</td><td>0.06</td></tr> <tr><td>≠0</td><td>≠0</td><td>≠0</td><td>0.07</td></tr> </tbody> </table> <p style="font-size: x-small; margin-top: 5px;">In the above table, ≠0 indicates that the corresponding input is not zero.</p>	INPUT C	INPUT B	INPUT A	OUTPUT	0	0	0	0.00	0	0	≠0	0.01	0	≠0	0	0.02	0	≠0	≠0	0.03	≠0	0	0	0.04	≠0	0	≠0	0.05	≠0	≠0	0	0.06	≠0	≠0	≠0	0.07
INPUT C	INPUT B	INPUT A	OUTPUT																																		
0	0	0	0.00																																		
0	0	≠0	0.01																																		
0	≠0	0	0.02																																		
0	≠0	≠0	0.03																																		
≠0	0	0	0.04																																		
≠0	0	≠0	0.05																																		
≠0	≠0	0	0.06																																		
≠0	≠0	≠0	0.07																																		

# 6-76 Programming Your Application

Operation	Description
ON DELAY	

A programmable delay between receiving and outputting a Boolean TRUE signal.

INPUT A becoming TRUE starts the delay timer. INPUT B sets the duration of the delay. At the end of the duration, OUTPUT becomes TRUE unless INPUT A has reverted to FALSE. Setting INPUT C to TRUE ( $\neq 0$ ) inverts the output.

OFF DELAY	
-----------	--

A programmable delay between receiving and outputting a Boolean FALSE signal.

INPUT A becoming FALSE starts the delay timer. INPUT B sets the duration of the delay. Setting INPUT C to TRUE ( $\neq 0$ ) inverts the output. At the end of the duration, OUTPUT becomes FALSE unless INPUT A has reverted to TRUE.

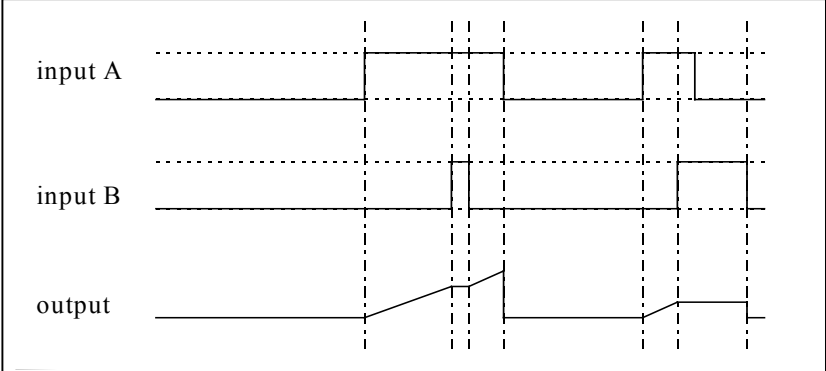
Operation	Description
TIMER	

Times the period elapsed from when INPUT A is set TRUE and held TRUE, to when INPUT B becomes TRUE.

OUTPUT is the duration of the timer, starting from zero. If INPUT B is TRUE, the value for OUTPUT is held until INPUT B is released. If on release INPUT A is still TRUE, the timer will continue from the held value. Setting INPUT A and INPUT B to FALSE resets the timer.

INPUT C is not used.

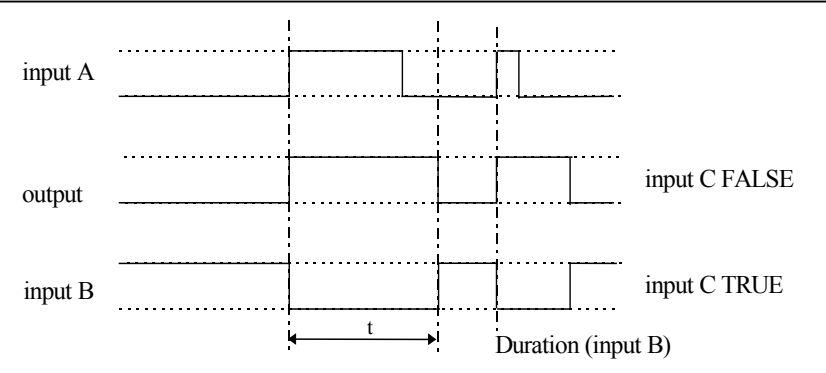
MINIMUM PULSE	
---------------	---

Creates an output pulse of adjustable minimum time when INPUT A is TRUE. (INPUT A is assumed to be a sequence of TRUE pulses and FALSE off periods.)

INPUT B sets the length of the minimum pulse required. INPUT C inverts the output when TRUE. The duration of the pulse is *at least* the period set by INPUT B.

# 6-78 Programming Your Application

Operation	Description
PULSE TRAIN	

Creates a pulsed TRUE/FALSE output of programmable frequency.

INPUT A enables the pulse train when TRUE, disables when FALSE.

INPUT B sets the length of the *on* part of the pulse. INPUT C sets the length of the *off* part of the pulse.

WINDOW	
--------	--

This function outputs TRUE when INPUT A is within a programmable range, and FALSE otherwise.

INPUT B sets the threshold of the window to be monitored. INPUT C defines the range of the window around the threshold. When the value of INPUT A is inside the window, the window expands by 1.00% to avoid flutter on output if noisy, i.e. if INPUT B = 5 and INPUT C = 4 then the range is 3 to 7, expanded to 2.5 to 7.5 when the value if INPUT A is inside the window.

If INPUT C is set to zero, the output will only be TRUE if INPUT A is exactly equal to INPUT B (this is fulfilled in the default condition when inputs A, B & C are all zero)

If INPUT C is set to a negative value, its absolute value defines the window range, and the output is inverted.

Operation	Description
UP/DOWN COUNTER	<div style="border: 1px solid black; padding: 10px; margin-bottom: 10px;"> <p>The diagram shows three horizontal lines representing signals over time. The top line is 'input A', the middle is 'input B', and the bottom is 'output'. Vertical dashed lines mark specific events. When input A has a rising edge, the output increases by one. When input B has a rising edge, the output decreases by one. The output is zero when input C is active. The output is limited to a range of ±30000 (±300.00%).</p> </div> <p>INPUT A provides a rising edge trigger to increment the output count by one.</p> <p>INPUT B provides a rising edge trigger to decrement the output count by one.</p> <p>INPUT C holds the output at zero.</p> <p>The output starts at zero. The output is limited at <math>\pm 30000</math> (<math>\pm 300.00\%</math>).</p>
(A*B)/C ROUND	The OUTPUT is set to $(\text{INPUT A} * \text{INPUT B}) / (\text{INPUT C})$ . This is the same as $(A*B)/C$ (enumerated value 3) except that the result is rounded.
WINDOW NO HYST	This is the same as WINDOW (enumerated value 19) except that there is no hysteresis when inside the 'window'. Thus, from the diagram given in WINDOW, if INPUT B = 5 and INPUT C = 4 then the range is 3 to 7.

## MMI Menu Map

1	SETUP PARAMETERS
2	FUNCTION BLOCKS
3	MOTOR CONTROL
4	VECTOR FLUXING
	VECTOR ENABLE
	MOTOR CONNECTION
	STATOR RES
	LEAKAGE INDUC
	MUTUAL INDUC
	SUPPLY VOLTAGE

## VECTOR FLUXING

This function block allows the user to both enable the sensorless vector fluxing mode and enter details of the motor to be controlled. Once enabled, vector fluxing automatically replaces the conventional V to F fluxing and enables slip compensation.

Refer to Chapter 4: “Operating the Inverter” - Setting-up the Inverter, for a description of the vector fluxing of the Inverter.

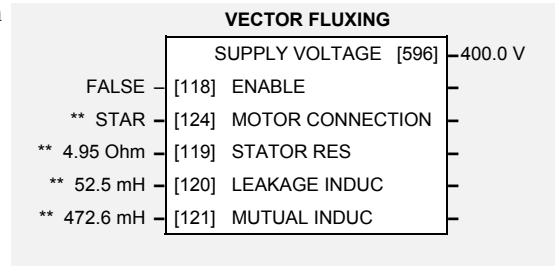

## Parameter Descriptions

### ENABLE

Range: FALSE / TRUE

This parameter enables sensorless vector Inverter operation.

**Note:** Cannot be enabled if Quadratic Torque mode is selected.

### MOTOR CONNECTION

Range: Enumerated - see below

This parameter is used to indicate how the motor is connected to the Inverter. The choice for this parameter is:

Enumerated Value : Motor Connection

- 0 : DELTA
- 1 : STAR

### STATOR RES

Range: 0.00 to 100.00 Ohm

This parameter is used to program the value of the motor per-phase stator resistance.

### LEAKAGE INDUC

Range: 0.0 to 1000.0 mH

This parameter is used to program the value of the motor per-phase stator leakage inductance.

### MUTUAL INDUC

Range: 0.0 to 1000.0 mH

This parameter is used to program the value of the motor per-phase stator mutual (magnetising) inductance.

### SUPPLY VOLTAGE

Range: xxxx.x V

This parameter indicates the line to line rms supply voltage to the Inverter.

## MMI Menu Map

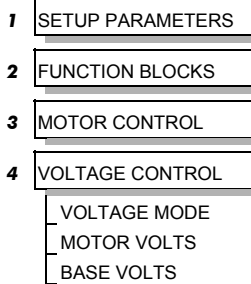

## VOLTAGE CONTROL

This is used to control voltage in two different modes.

A benefit of using this function block is that it can reduce the possibility of nuisance tripping due to fluctuations in stator current.

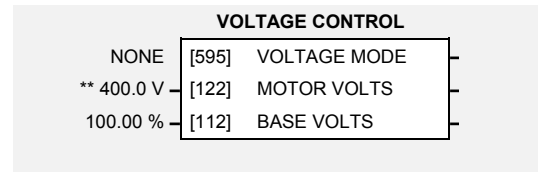

## Parameter Descriptions

### VOLTAGE MODE

*Range: Enumerated - see below*

Set to NONE, no attempt is made to control the PWM modulation depth for variations in dc link voltage.

Set to FIXED, the Inverter's output volts are maintained, regardless of variations in the dc link voltage. The Inverter's product code sets the default value for demanded maximum output voltage (see MOTOR VOLTS below).

Set to AUTOMATIC, the voltage is controlled as above, but the output voltage is allowed to rise smoothly as dc link volts vary. This allows the motor to be overfluxed during deceleration, thereby increasing braking performance.

*Enumerated Value : Voltage Mode*

- 0 : NONE
- 1 : FIXED
- 2 : AUTOMATIC

### MOTOR VOLTS

*Range: 198.0 to 550.0 V*

This is the maximum motor output voltage. This parameter is used in conjunction with the VOLTAGE MODE parameter above when set to FIXED.

### BASE VOLTS

*Range: 0.00 to 115.47 %*

This parameter directly scales the output of the voltage control function block, thus allowing further scaling of the Inverter output volts if required.

## MMI Menu Map

- 1 SETUP PARAMETERS
- 2 FUNCTION BLOCKS
- 3 SEQ & REF
- 4 ZERO SPEED
  - ZERO SPEED IN
  - ZERO SPEED LEVEL
  - ZERO SPEED BAND
  - AT ZERO SPEED

## ZERO SPEED

This function block detects when the speed is at or close to zero. LEVEL and BAND are user-definable.

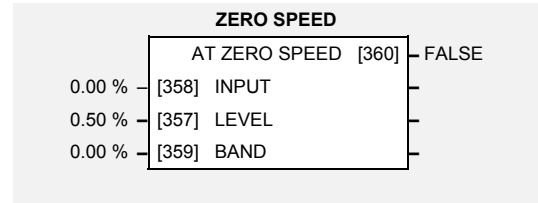

## Parameter Descriptions

### INPUT

Speed input.

Range: -300.00 to 300.00 %

### LEVEL

Sets the level, below which is considered to be zero.

Range: 0.00 to 100.00 %

### BAND

Creates a window both sides of the level set above.

Range: -300.00 to 300.00 %

### AT ZERO SPEED

TRUE when at zero, as defined by the LEVEL and BAND parameters.

Range: FALSE / TRUE

## Functional Description

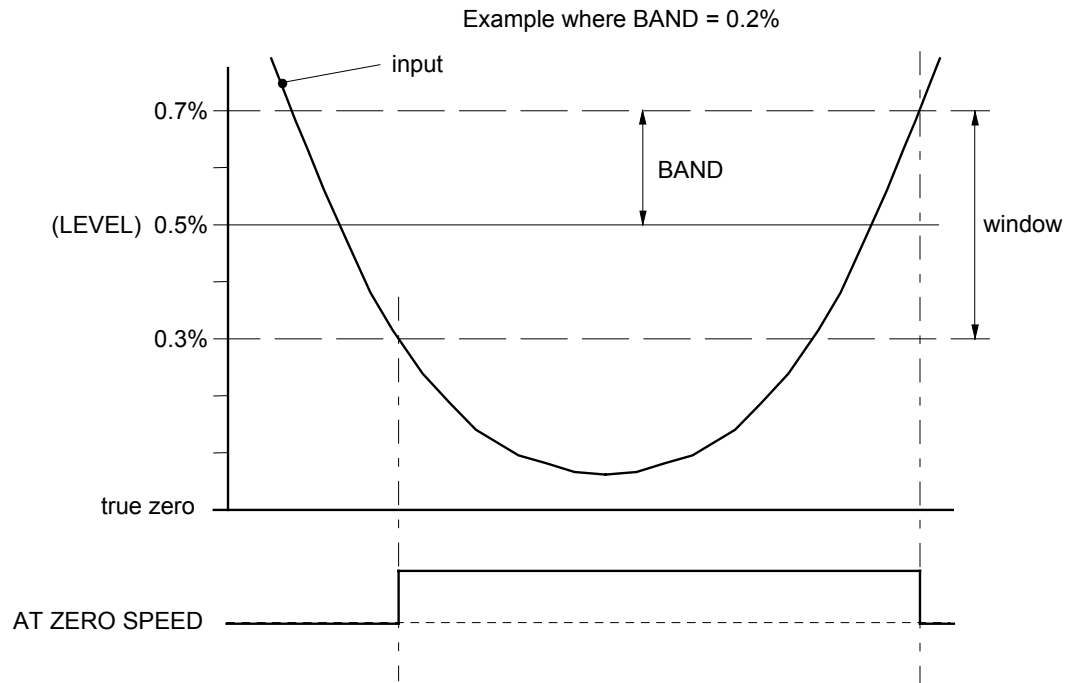

## Motor-Specific Parameters

When copying an application from the Operator Station to another Inverter, the following motor-specific parameters need not be written to - refer to Chapter 5: "The Operator Station" - Copying an Application.

	Tag
FLY SEARCH BOOST	32
FULL LOAD CALIB	64
NO LOAD CALIB	65
NAMEPLATE RPM	83
MOTOR POLES	84
SLIP MOTOR LIMIT	85
SLIP REGEN LIMIT	86
DEFLUX DELAY	100
BASE FREQUENCY	106
FIXED BOOST	107
AUTO BOOST	108
STATOR RES	119
LEAKAGE INDUC	120
MUTUAL INDUC	121
MOTOR VOLTS	122
VECTOR FILTER TC	123
MOTOR CONNECTION	124
POWER FACTOR	242
ENCODER LINES	566
FLY SEARCH VOLTS	573
FLY SEARCH TIME	574
INJ FREQUENCY	577
INJ DC PULSE	579
INJ FINAL DC	580
INJ DC LEVEL	581
DEFLUX TIME	710
INJ BASE VOLTS	739

## Quadratic Torque Selection

- MMI Menu Map**
- 1 SETUP PARAMETERS
  - 2 QUICK SETUP
  - QUADRATIC TORQUE

or

- MMI Menu Map**
- 1 SETUP PARAMETERS
  - 2 FUNCTION BLOCKS
  - 3 MOTOR CONTROL
  - 4 CURRENT FEEDBACK
  - QUADRATIC TORQUE

When selecting or de-selecting Quadratic Torque mode, several parameter values and their limits are modified.

The parameters affected are shown in the table below.

**Note:** When changing to or from Quadratic Mode, you will be requested to confirm your actions on the MMI. This is intended to remind you of the effects detailed below.

Change from CONSTANT TORQUE to QUADRATIC TORQUE				
Tag	Function Block	Parameter	Set to:	Note
99	PATTERN GEN	FREQ SELECT	3kHz	Cannot be changed
118	VECTOR FLUXING	ENABLE	FALSE	Cannot be changed
238	I*† TRIP	TIME	10s	High limit now 10s
239	I*† TRIP	UPPER LIMIT	115.00%	High limit now 115.00%
64	CURRENT FEEDBACK	FULL LOAD CALIB	Output current Amps	Refer to Chapter 11: "Technical Specifications", Electrical Ratings (quadratic torque)
65	CURRENT FEEDBACK	NO LOAD CALIB	30% of output current Amps	Refer to Chapter 11: "Technical Specifications", Electrical Ratings (quadratic torque)
365	CURRENT LIMIT	MOTOR LIMIT	115.00%	High limit now 115.00%
623	CURRENT LIMIT	REGEN I LIMIT	-115.00%	Low limit now -115.00%

Change from QUADRATIC TORQUE to CONSTANT TORQUE				
Tag	Function Block	Parameter	Set to:	Note
99	PATTERN GEN	FREQ SELECT	3kHz	Can be changed
118	VECTOR FLUXING	ENABLE	FALSE	Can be changed
238	I*† TRIP	TIME	60s	High limit now 60s
239	I*† TRIP	UPPER LIMIT	150.00%	High limit now 150.00%
64	CURRENT FEEDBACK	FULL LOAD CALIB	Default FULL LOAD CALIB Amps	Refer to Chapter 10: "Parameter Specification", Power Rating Dependant Defaults
65	CURRENT FEEDBACK	NO LOAD CALIB	Default NO LOAD CALIB Amps	Refer to Chapter 10: "Parameter Specification", Power Rating Dependant Defaults
365	CURRENT LIMIT	MOTOR LIMIT	150.00%	High limit now 150.00%
623	CURRENT LIMIT	REGEN I LIMIT	-150.00%	Low limit now -150.00%

# TRIPS AND FAULT FINDING

## Trips

### What Happens when a Trip Occurs

When a trip occurs, the Inverter's power stage is immediately disabled causing the motor and load to coast to a stop. The trip is latched until action is taken to reset it. This ensures that trips due to transient conditions are captured and the Inverter is disabled, even when the original cause of the trip is no longer present

### Inverter Indications

If a trip condition is detected the unit displays and performs the following actions.

1. The HEALTH LED flashes indicating a Trip condition has occurred. (Investigate, find and remove the cause of the trip.)
1. The programming block SEQUENCING LOGIC::TRIPPED signal is set to TRUE. The DIGITAL OUTPUT 1 (HEALTH) digital output changes between TRUE/FALSE, depending on the output logic.

DEFAULT

### Operator Station Indications (when connected)

If a trip condition is detected the MMI displays and performs the following actions.

1. The HEALTH LED on the Operator Station flashes indicating a Trip condition has occurred and a trip message is displayed stating the cause of the trip.
2. The programming block SEQUENCING LOGIC::TRIPPED signal is set to TRUE. The DIGITAL OUTPUT 1 (HEALTH) digital output changes between TRUE/FALSE, depending on the output logic.
3. The trip message(s) must be acknowledged by pressing the **E** key. Refer to Chapter 5: "The Operator Station" - Alert Message Displays.

### Resetting a Trip Condition

All trips must be reset before the Inverter can be re-enabled. A trip can only be reset once the trip condition is no longer active, i.e. a trip due to a heatsink over-temperature will not reset until the temperature is below the trip level.

**Note:** *More than one trip can be active at any time. For example, it is possible for both the HEATSINK TEMP and the LINK OVERVOLTS trips to be active. Alternatively it is possible for the Inverter to trip due to an OVERCURRENT error and then for the HEATSINK TEMP trip to become active after the Inverter has stopped (this may occur due to the thermal time constant of the heatsink).*

DEFAULT

Reset the trip(s) using the remote trip reset input, or by pressing the **STOP/RESET** key on the Operator Station.

Success is indicated by the HEALTH LED (on the unit or MMI) ceasing to flash and returning to a healthy "ON" state. The programming block SEQUENCING LOGIC::TRIPPED output is reset to FALSE.

## 7-2 Trips and Fault Finding

### Using the Operator Station to Manage Trips

#### Trip Messages

If the Inverter trips, then the display immediately shows a message indicating the reason for the trip. The possible trip messages are given in the table below.

Trip Message and Meaning	Possible Reason for Trip
<b>LINK OVERVOLTS</b> The Inverter internal dc link voltage is too high	The supply voltage is too high Trying to decelerate a large inertia load too quickly The brake resistor is open circuit
<b>LINK UNDERVOLT</b> The Inverter internal dc link voltage is too low	The supply voltage is too low The supply has been lost A supply phase is missing
<b>OVERCURRENT</b> The motor current being drawn from the Inverter is too high	Trying to accelerate a large inertia load too quickly Trying to decelerate a large inertia load too quickly Application of shock load to motor Short circuit between motor phases Short circuit between motor phase and earth Motor output cables too long or too many parallel motors connected to the Inverter Fixed or auto boost levels are set too high
<b>HEATSINK TEMP</b> The Inverter heatsink temperature is too high	The ambient air temperature is too high Poor ventilation or spacing between Inverters
<b>EXTERNAL TRIP</b> User trip caused via control terminals	+24V not present on external trip (e.g. terminal 16, Macro 1).
<b>INPUT 1 BREAK</b> A signal break has been detected on analog input 1 (terminal 1)	Analog input is incorrectly configured for 4-20mA operation Break in external control wiring
<b>INPUT 2 BREAK</b> A signal break has been detected on analog input 2 (terminal 2)	Analog input is incorrectly configured for 4-20mA operation Break in external control wiring
<b>MOTOR STALLED</b> The motor has stalled (not rotating)	Motor loading too great Current limit level is set too low Stall trip duration is set too low Fixed or auto boost levels are set too high
<b>I*<sub>t</sub> TRIP</b> The motor current drawn from the Inverter has exceeded the user set I* <sub>t</sub> levels	Motor loading is too great I* <sub>t</sub> threshold level is set too low I* <sub>t</sub> upper limit level is set too low I* <sub>t</sub> time duration is set too low
<b>BRAKE RESISTOR</b> External dynamic braking resistor has been overloaded	Trying to decelerate a large inertia load too quickly or too often
<b>BRAKE SWITCH</b> Internal dynamic braking switch has been overloaded	Trying to decelerate a large inertia load too quickly or too often

Trip Message and Meaning	Possible Reason for Trip
<b>OP STATION</b> Operator Station has been disconnected from Inverter whilst Inverter is running in local control	Operator Station accidentally disconnected from Inverter
<b>LOST COMMS</b>	COMMS TIMEOUT parameter set too short (refer to COMMS CONTROL menu at level 4)
<b>MOTOR TEMP</b> The motor temperature is too high	Excessive load Motor voltage rating incorrect FIXED BOOST and/or AUTO BOOST set too high Prolonged operation of the motor at low speed without forced cooling Check setting of INVERT THERMIST parameter in TRIPS STATUS menu at level 1. Break in motor thermistor connection
<b>CURRENT LIMIT</b> If the current exceeds 180% of stack rated current for a period of 1 second, the Inverter will trip. This is caused by shock loads	Remove the cause of the shock load
<b>SHORT CIRCUIT</b>	The output is short circuited
<b>24V FAILURE</b> The 24V customer output has fallen below 17V	24V customer output is short circuited Excessive loading
<b>LOW SPEED I</b> The motor is drawing too much current (>100%) at zero output frequency	FIXED BOOST and/or AUTO BOOST set too high (refer to FLUXING menu at level 4)
<b>PHASE FAIL</b> An input supply phase is missing	Supply phase wire break Blown supply fuse Tripped supply circuit breaker

**Table 7-1 Trip Messages**

## Automatic Trip Reset

Using the Operator Station, the Inverter can be configured to automatically attempt to reset a trip when an attempt is made to start driving the motor, or after a preset time once the trip condition has occurred. The following function blocks (MMI menus) are used to enable automatic trip resets.

- Auto Restart (Auto-Reset)
- Sequencing Logic

## Setting Trip Conditions

The following function blocks (MMI menus) are used to set trip conditions:

- I/O Trips
- I\*t Trip
- Stall Trip
- Trips Status

## Viewing Trip Conditions

The following function blocks (MMI menus) can be viewed to investigate trip conditions:

- Sequencing Logic
- Trips History
- Trips Status

## 7-4 Trips and Fault Finding

### Checksum Fail

When the Inverter powers-up, non-volatile memory is checked to ensure that it has not been corrupted. In the rare event of corruption being detected, the Inverter will not function. This may occur when replacing the control board with an unprogrammed control board.

### Inverter Indications

DEFAULT

The failure is indicated by the HEALTH and RUN LEDs showing SHORT FLASH, .

Referring to Chapter 4: “Operating the Inverter” - Reading the Status LEDs, you will note that this also indicates Re-configuration mode, but this mode (and hence the indication) is not available to the Inverter unless controlled by an MMI or Comms link.

Because you are controlling the Inverter locally (no MMI or Comms link etc.), the unit must be returned to SSD Drives for reprogramming, refer to Chapter 8: “Routine Maintenance and Repair” for address details. However, if you have access to an Operator Station or suitable PC programming tool, the unit can be reset.

### Operator Station Indications (when connected)

The MMI displays the message opposite.

Acknowledge the message by pressing the E key. This action automatically loads and saves Macro 1 default parameters and the ENGLISH 50Hz Product Code.

If your unit was using a different Product Code or macro, you must reload the Product Code of your choice, reload the macro of your choice, and perform a Parameter Save (SAVE/COMMAND menu) in that order.

If data will not save correctly, the Operator Station will display a failure message. In this case, the Inverter has developed a fault and must be returned to SSD Drives. Refer to Chapter 8: “Routine Maintenance and Repair” for address details.

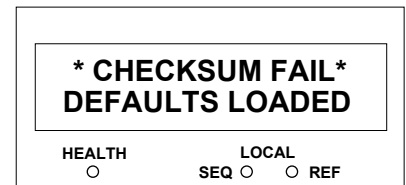

## Fault Finding

Problem	Possible Cause	Remedy
Inverter will not power-up	Fuse blown	Check supply details, replace with correct fuse. Check Product Code against Model No.
	Faulty cabling	Check all connections are correct and secure. Check cable continuity
Inverter fuse keeps blowing	Faulty cabling or connections wrong Faulty Inverter	Check for problem and rectify before replacing with correct fuse Contact SSD Drives
Cannot obtain HEALTH state	Incorrect or no supply available	Check supply details
Motor will not run at switch-on	Motor jammed	Stop the Inverter and clear the jam
Motor runs and stops	Motor becomes jammed	Stop the Inverter and clear the jam
Motor won't rotate or runs in reverse	Encoder fault	Check encoder connections
	Open circuit speed reference potentiometer	Check terminal

Table 7-2 Fault Finding

# ROUTINE MAINTENANCE AND REPAIR

## Routine Maintenance

Periodically inspect the Inverter for build-up of dust or obstructions that may affect ventilation of the unit. Remove this using dry air.

## Repair

There are no user-serviceable components.

**IMPORTANT:** MAKE NO ATTEMPT TO REPAIR THE UNIT - RETURN IT TO SSD DRIVES.

### Saving Your Application Data

Although the Inverter retains saved settings during power-down, it would be wise for you to keep your Operator Station. If your last SAVE TO OP function was made on this unit before the fault occurred, then the Operator Station will still hold your application data. You can transfer this back into the repaired unit, if necessary. You may, depending upon your knowledge of the fault, attempt the back-up of your application data now, refer to Chapter 5: “The Operator Station” - Copying an Application.

If the fault clearly lies within the Operator Station, then return it for repair.

### Returning the Unit to SSD Drives

Please have the following information available:

- The model and serial number - see the unit’s rating label
- Details of the fault

Contact your nearest SSD Drives Service Centre to arrange return of the item.

You will be given a *Returned Material Authorisation*. Use this as a reference on all paperwork you return with the faulty item. Pack and despatch the item in the original packing materials; or at least an anti-static enclosure. Do not allow packaging chips to enter the unit.

### Disposal

This product contains materials which are consignable waste under the Special Waste Regulations 1996 which complies with the EC Hazardous Waste Directive - Directive 91/689/EEC.

We recommend you dispose of the appropriate materials in accordance with the valid environmental control laws. The following table shows which materials can be recycled and which have to be disposed of in a special way.

Material	Recycle	Disposal
metal	yes	no
plastics material	yes	no
printed circuit board	no	yes

The printed circuit board should be disposed of in one of two ways:

1. High temperature incineration (minimum temperature 1200°C) by an incinerator authorised under parts A or B of the Environmental Protection Act
2. Disposal in an engineered land fill site that is licensed to take aluminium electrolytic capacitors. Do not dispose of in a land fill site set aside for domestic waste.

### Packaging

During transport our products are protected by suitable packaging. This is entirely environmentally compatible and should be taken for central disposal as secondary raw material.

# 8-2 Routine Maintenance and Repair

# SEQUENCING LOGIC STATES

## Principle State Machine

The Inverter's reaction to commands is defined by a state machine. This determines which commands provide the demanded action, and in which sequence.

### Main Sequencing States

The main sequencing state of the unit is indicated by an enumerated value given by the parameter MAIN SEQ STATE under SEQUENCING LOGIC menu at level 4.

Enumerated Value	Main Seq State	Standard Name	Description
0	NOT READY	Not Ready To Switch On	Power up initialisation, or configuration mode. No command will be accepted
1	START DISABLED	Switch On Disabled	The Inverter will not accept a switch on command
2	START ENABLED	Ready To Switch On	The Inverter will accept a switch on command
3	SWITCHED ON	Switched On	The Inverter's stack is enabled
4	ENABLED	Enabled	The Inverter is enabled and operational
5	F-STOP ACTIVE	Fast-Stop Active	Fast stop is active
6	TRIP ACTIVE	Trip Active	The Inverter is processing a trip event
7	TRIPPED	Tripped	The Inverter is tripped awaiting trip reset

Table 9-1 Enumerated Values for the SEQUENCING LOGIC Function Block

### State Outputs of the SEQUENCING LOGIC Function Block

The following table shows the states of individual parameters for the SEQUENCING LOGIC function block required to produce the condition of the MAIN SEQ STATE parameter.

	NOT READY	START DISABLED	START ENABLED	SWITCHED ON	ENABLED	F-STOP ACTIVE	TRIP ACTIVE	TRIPPED
<b>Tripped</b>	FALSE	FALSE	FALSE	FALSE	FALSE	FALSE	TRUE	TRUE
<b>Running</b>	FALSE	FALSE	FALSE	FALSE	TRUE	FALSE	FALSE	FALSE
<b>Jogging</b>	FALSE	FALSE	FALSE	FALSE	Note 1	FALSE	FALSE	FALSE
<b>Stopping</b>	FALSE	FALSE	FALSE	FALSE	Note 2	TRUE	FALSE	FALSE
<b>Output Contactor</b>	FALSE	Depends on previous state	Depends on previous state	TRUE	TRUE	TRUE	TRUE	FALSE
<b>Switch On Enable</b>	FALSE	FALSE	TRUE	TRUE	TRUE	TRUE	TRUE	FALSE
<b>Switched On</b>	FALSE	FALSE	FALSE	TRUE	TRUE	TRUE	TRUE	FALSE
<b>Ready</b>	FALSE	FALSE	FALSE	TRUE	TRUE	TRUE	TRUE	FALSE
<b>Healthy O/P</b>	TRUE	TRUE	TRUE	TRUE	TRUE	TRUE	FALSE	FALSE Note 3

Table 9-2 Parameter States for the MAIN SEQ STATE Parameter

## 9-2 Sequencing Logic

- Note:**
1. Jogging is set TRUE once the jog cycle has started, and remains TRUE until the jog cycle has finished which is when either the stop delay has finished or another mode is demanded.
  2. Stopping is set TRUE during the stopping cycles commanded by either RUN going low, JOG going low or if Fast Stop is active.
  3. Once Run and Jog are both FALSE, HEALTHY O/P will be set TRUE.

### Transition of States

The transition matrix describes what causes the transition from one state to another, for example see no. 5 below: the transition from “Ready To Switch On” to “Trip Active” is triggered by “TRIP” going TRUE.

Refer to the following table and state diagram.

	Current State	Next State	Cause (FALSE to TRUE)
1	Power Up	Not Ready To Switch On	Reset OR initialise
2	Not Ready To Switch On	Switch On Disabled	Initialise complete AND NOT re-configuration mode
3	Switch On Disabled	Trip Active	Trip
4	Switch On Disabled	Ready To Switch On	NOT Run AND NOT Jog AND /Fast-Stop AND /Coast-Stop
5	Ready To Switch On	Trip Active	Trip
6	Ready To Switch On	Switch On Disabled	NOT /Coast-Stop OR NOT /Fast-Stop
7	Ready To Switch On	Switched On	Run OR Jog
8	Switched On	Trip Active	Trip
9	Switched On	Switch On Disabled	NOT /Coast-Stop OR NOT /Fast-Stop
10	Switched On	Ready To Switch On	NOT Run AND NOT Jog
11	Switched On	Enabled	Inverter Enable
12	Enabled	Trip Active	Trip
13	Enabled	Switch On Disabled	NOT /Coast Stop
14	Enabled	Fast Stop Active	NOT /Fast Stop
15	Enabled	Switched On	NOT Inverter Enable
16	Enabled	Ready To Switch On	NOT Run AND NOT Jog AND stop sequence complete
17	Fast Stop Active	Trip Active	Trip
18	Fast Stop Active	Switch On Disabled	Fast Stop timer expired OR Fast Stop Mode = Coast Stop OR Inverter at zero setpoint
19	Trip Active	Tripped	Stack quenched
20	Tripped	Switch On Disabled	NOT Trip AND Trip Reset 0->1 transition

**Table 9-3 Transition Matrix**

**State Diagram**

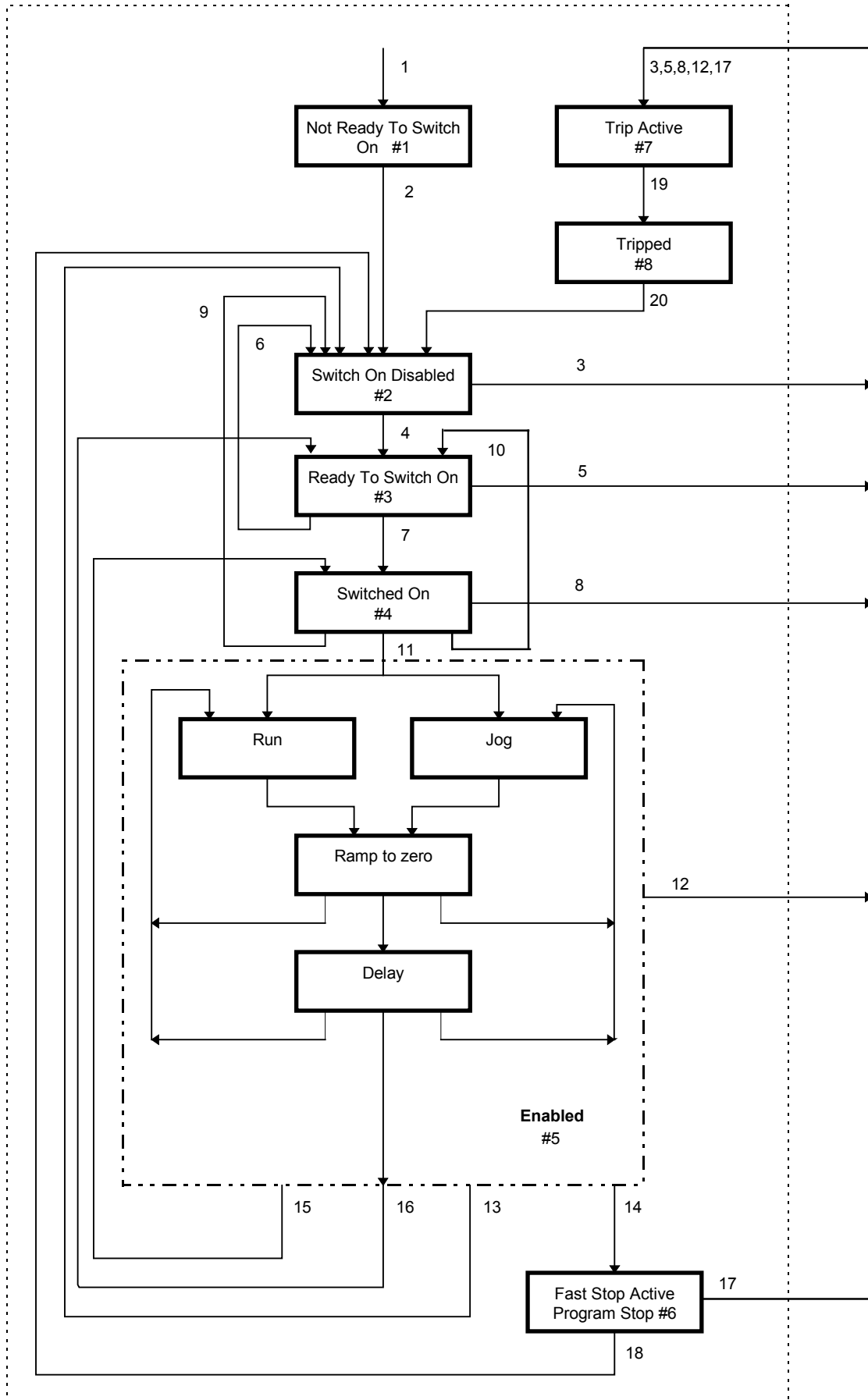

## External Control of the Inverter

### Communications Command

When sequencing is in the Remote Comms mode, the sequencing of the Inverter is controlled by writing to the hidden parameter COMMS COMMAND (Tag 271). This parameter can only be written to using a communications interface. The output parameter (Tag 273) COMMS COMMAND of the COMMS CONTROL function block is provided as a diagnostic.

The COMMS COMMAND parameter is a 16-bit word based on standard fieldbus drive profiles. Some bits are not implemented in this release (see “Supported” column of the table below).

Bit	Name	Description	Supported	Required Value
0	Switch On	OFF1 Operational	√	
1	(Not) Disable Voltage	OFF2 Coast Stop	√	
2	(Not) Quick Stop	OFF3 Fast Stop	√	
3	Enable Operation		√	
4	Enable Ramp Output	=0 to set ramp output to zero		1
5	Enable Ramp	=0 to hold ramp		1
6	Enable Ramp Input	=0 to set ramp input to zero		1
7	Reset Fault	Reset on 0 to 1 transition	√	
8				0
9				0
10	Remote	=1 to control remotely		1
11				0
12				0
13				0
14				0
15				0

### Switch On

Replaces the RUN FWD, RUN REV and /STOP parameters of the SEQUENCING LOGIC function block. When Set (=1) is the same as :

RUN FWD = TRUE  
 RUN REV = FALSE  
 /STOP = FALSE

When Cleared (= 0) is the same as :

RUN FWD = FALSE  
 RUN REV = FALSE  
 /STOP = FALSE

### (Not) Disable Voltage

Replaces the /COAST STOP parameter of the SEQUENCING LOGIC function block. When Set (=1) is the same as:

/COAST STOP = TRUE

When Cleared (= 0) is the same as :

/COAST STOP = FALSE

**(Not) Quick Stop**

Replaces the /FAST STOP parameter on the SEQUENCING LOGIC function block.  
When Set (=1) is the same as:

/FAST STOP = TRUE

When Cleared (= 0) is the same as :

/FAST STOP = FALSE

**Enable Operation**

Replaces the DRIVE ENABLE parameter on the SEQUENCING LOGIC function block.  
When Set (=1) is the same as:

DRIVE ENABLE = TRUE

When Cleared (= 0) is the same as :

DRIVE ENABLE = FALSE

**Enable Ramp Output, Enable Ramp, Enable Ramp Input**

Not implemented. The state of these bits must be set (=1) to allow this feature to be added in the future.

**Reset Fault**

Replaces the REM TRIP RESET parameter on the SEQUENCING LOGIC function block.  
When Set (=1) is the same as:

REM TRIP RESET = TRUE

When Cleared (= 0) is the same as :

REM TRIP RESET = FALSE

**Remote**

Not implemented. It is intended to allow the PLC to toggle between local and remote. The state of this must be set (=1) to allow this feature to be added in the future.

**Example Commands**

047F hexadecimal to RUN

047E hexadecimal to STOP

## 9-6 Sequencing Logic

### Communications Status

The COMMS STATUS parameter (Tag 272) in the COMMS CONTROL function block monitors the sequencing of the Inverter. It is a 16-bit word based on standard fieldbus drive profiles. Some bits are not implemented in the initial release and are set to 0 (see “Supported” column of the table below).

Bit	Name	Description	Supported
0	Ready To Switch On		√
1	Switched On	Ready for operation (refer control bit 0)	√
2	Operation Enabled	(refer control bit 3)	√
3	Fault	Tripped	√
4	(Not) Voltage Disabled	OFF 2 Command pending	√
5	(Not) Quick Stop	OFF 3 Command pending	√
6	Switch On Disable	Switch On Inhibited	√
7	Warning		
8	SP / PV in Range		
9	Remote	= 1 if Drive will accept Command Word	√
10	Setpoint Reached		
11	Internal Limit Active		
12			
13			
14			
15			

#### Ready To Switch On

Same as the SWITCH ON ENABLE output parameter of the SEQUENCING LOGIC function block.

#### Switched On

Same as the SWITCHED ON output parameter of the SEQUENCING LOGIC function block.

#### Operation Enabled

Same as the RUNNING output parameter of the SEQUENCING LOGIC function block.

#### Fault

Same as the TRIPPED output parameter of the SEQUENCING LOGIC function block.

#### (Not) Voltage Disabled

If in REMOTE COMMS mode, this is the same as Bit 1 of the COMMS COMMAND parameter. Otherwise it is the same as the /COAST STOP input parameter of the SEQUENCING LOGIC function block.

#### (Not) Quick Stop

If in REMOTE COMMS mode, this is the same as Bit 2 of the COMMS COMMAND parameter. Otherwise it is the same as the /FAST STOP input parameter of the SEQUENCING LOGIC function block.

#### Switch On Disable

Set (=1) only when in START DISABLED state.

#### Remote

This bit is set (= 1) if the Inverter is in Remote mode AND the parameter REMOTE COMMS SEL of the COMMS CONTROL function block is Set (= 1).

# PARAMETER SPECIFICATION

The headings for the Tag No. table are described below.

<b>Tag</b>	A numeric identification of the parameter. It is used to identify the source and destinations of internal links.
<b>Name</b>	The parameter name as it appears on the MMI.
<b>Block</b>	The menu page and function block under which the parameter is stored.
<b>Type</b>	<p>INT Fixed point value - 16 bits</p> <p>BOOL A Boolean (bit) representing FALSE or TRUE</p> <p>ENUM An enumerated value representing a selection</p> <p>STRING An ASCII string</p> <p>TAG A value representing a choice of TAG</p> <p>D_TAG A value representing a choice of Destination tag as an internal link</p> <p>S_TAG A value representing a choice of Source tag as an internal link</p> <p>WORD 16 Bit hexadecimal number</p>
<b>Range</b>	<p>This varies with parameter type:</p> <p>INT The upper and lower limits of the parameter, indicating the parameter's true, internally-held, number of decimal (a reduced number of digits may be shown by the Operator Station).</p> <p>BOOL 0 = FALSE, 1 = TRUE</p> <p>ENUM A list of possible selections for that parameter</p> <p>STRING Specified number of characters</p> <p>TAG The tag number of any parameter</p> <p>D_TAG The tag number of an input parameter</p> <p>S_TAG The tag number of an input or output parameter. (May be set to a negative value indicating a feedback link).</p> <p>WORD 0000 to FFFF (hexadecimal)</p>
<b>ID</b>	Serial Communications Mnemonic: Refer to Chapter 14: "Serial Communications"
<b>Notes</b>	<p>You can record your application's settings here.</p> <p>Output parameters are not saved in non-volatile memory.</p> <ol style="list-style-type: none"> <li>1. This input parameter is not saved in non-volatile memory.</li> <li>2. This parameter is automatically saved in non-volatile memory.</li> <li>3. This parameter forms part of the motor configuration.</li> <li>4. This parameter is not adjustable from the operator station.</li> <li>5. This parameter cannot be the destination of a link.</li> <li>6. This parameter cannot be the source of a link.</li> <li>7. This parameter can only be written to when the Inverter is stopped.</li> <li>8. This parameter can only be written to when the Inverter is in configuration mode.</li> </ol>

# 10-2 Parameter Specification

## Specification Table: Tag Number Order

Tag	(MMI) Name	Block	Type	Range	ID	Notes
1	LANGUAGE	OP STATION	ENUM	0 : ENGLISH 1 : DEUTSCH 2 : FRANCAIS 3 : ESPANOL	01	
3	VIEW LEVEL	OP STATION	ENUM	0 : OPERATOR 1 : BASIC 2 : ADVANCED 3 : RESERVED 4 : ENGINEERING	03	
4	ACTIVE TRIPS	TRIPS STATUS	WORD	0000 to FFFF	04	Output
5	TRIP WARNINGS	TRIPS STATUS	WORD	0000 to FFFF	05	Output
6	FIRST TRIP	TRIPS STATUS	ENUM	0 : NO TRIP 1 : LINK OVERVOLTS 2 : LINK UNDERVOLT 3 : OVERCURRENT 4 : HEATSINK TEMP 5 : EXTERNAL TRIP 6 : INPUT 1 BREAK 7 : INPUT 2 BREAK 8 : MOTOR STALLED 9 : I*T TRIP 10 : BRAKE RESISTOR 11 : BRAKE SWITCH 12 : OP STATION 13 : LOST COMMS 14 : 15 : 16 : 17 : MOTOR TEMP 18 : CURRENT LIMIT 19 : SHORT CIRCUIT 20 : 24V FAILURE 21 : LOW SPEED I 22 : PHASE FAIL	06	Output
7	ENTER PASSWORD	PASSWORD	WORD	0000 to FFFF	07	1, 5, 6
8	CHANGE PASSWORD	PASSWORD	WORD	0000 to FFFF	08	5, 6
12	AIN 1 BREAK ENBL	ANALOG INPUT 1	BOOL	FALSE / TRUE	0c	
13	AIN 1 TYPE	ANALOG INPUT 1	ENUM	0 : 0..+10 V 1 : +2..+10 V 2 : 0..+5 V 3 : +1..+5 V 4 : -10..+10 V 5 : 0..20 mA 6 : 4..20 mA 7 : 20..4 mA 8 : 20..0 mA	0d	7
14	AIN 1 SCALE	ANALOG INPUT 1	INT	-300.00 to 300.00 %	0e	
15	AIN 1 OFFSET	ANALOG INPUT 1	INT	-300.00 to 300.00 %	0f	
16	AIN 1 VALUE	ANALOG INPUT 1	INT	xxx.xx %	0g	Output
17	AIN 1 BREAK VAL	ANALOG INPUT 1	INT	-300.00 to 300.00 %	0h	
18	AIN 1 BREAK	ANALOG INPUT 1	BOOL	FALSE / TRUE	0i	Output
21	AIN 2 BREAK ENBL	ANALOG INPUT 2	BOOL	FALSE / TRUE	0l	
22	AIN 2 TYPE	ANALOG INPUT 2	ENUM	Same as tag 13	0m	7
23	AIN 2 SCALE	ANALOG INPUT 2	INT	-300.00 to 300.00 %	0n	
24	AIN 2 OFFSET	ANALOG INPUT 2	INT	-300.00 to 300.00 %	0o	
25	AIN 2 VALUE	ANALOG INPUT 2	INT	xxx.xx %	0p	Output
26	AIN 2 BREAK VAL	ANALOG INPUT 2	INT	-300.00 to 300.00 %	0q	
27	AIN 2 BREAK	ANALOG INPUT 2	BOOL	FALSE / TRUE	0r	Output

# Parameter Specification 10-3

Tag	(MMI) Name	Block	Type	Range	ID	Notes
28	FLY SETPOINT	FLY CATCHING	INT	xxx.xx %	0s	Output
30	DIN 1 INVERT	DIGITAL INPUT 1	BOOL	FALSE / TRUE	0u	
31	DIN 1 VALUE	DIGITAL INPUT 1	BOOL	FALSE / TRUE	0v	Output
32	FLY SEARCH BOOST	FLY CATCHING	INT	0.00 to 100.00 %	0w	3
33	DIN 2 INVERT	DIGITAL INPUT 2	BOOL	FALSE / TRUE	0x	
34	DIN 2 VALUE	DIGITAL INPUT 2	BOOL	FALSE / TRUE	0y	Output
36	DIN 3 INVERT	DIGITAL INPUT 3	BOOL	FALSE / TRUE	10	
37	DIN 3 VALUE	DIGITAL INPUT 3	BOOL	FALSE / TRUE	11	Output
39	DIN 4 INVERT	DIGITAL INPUT 4	BOOL	FALSE / TRUE	13	
40	DIN 4 VALUE	DIGITAL INPUT 4	BOOL	FALSE / TRUE	14	Output
42	DIN 5 INVERT	DIGITAL INPUT 5	BOOL	FALSE / TRUE	16	
43	DIN 5 VALUE	DIGITAL INPUT 5	BOOL	FALSE / TRUE	17	Output
44	COEFFICIENT B	CUSTOM SCREEN 1	INT	1 to 30000	18	
45	AOUT 1 VALUE	ANALOG OUTPUT 1	INT	-300.00 to 300.00 %	19	
46	AOUT 1 SCALE	ANALOG OUTPUT 1	INT	-300.00 to 300.00 %	1a	
47	AOUT 1 OFFSET	ANALOG OUTPUT 1	INT	-300.00 to 300.00 %	1b	
48	AOUT 1 ABS	ANALOG OUTPUT 1	BOOL	FALSE / TRUE	1c	
49	AOUT 1 TYPE	ANALOG OUTPUT 1	ENUM	0 : 0..+10 V 1 : 0..20 mA 2 : 4..20 mA	1d	7
50	QUADRATIC TORQUE	CURRENT FEEDBACK	BOOL	FALSE / TRUE	1e	5, 7
51	DOUT 1 INVERT	DIGITAL OUTPUT 1	BOOL	FALSE / TRUE	1f	
52	DOUT 1 VALUE	DIGITAL OUTPUT 1	BOOL	FALSE / TRUE	1g	
53	LOW LIMIT	CUSTOM SCREEN 1	INT	-30000 to 30000	1h	
54	DOUT 2 INVERT	DIGITAL OUTPUT 2	BOOL	FALSE / TRUE	1i	
55	DOUT 2 VALUE	DIGITAL OUTPUT 2	BOOL	FALSE / TRUE	1j	
57	MAX SPEED	SETPOINT SCALE	INT	0.0 to 480.0 Hz	1l	7
58	SCALE INPUT	SETPOINT SCALE	INT	-300.00 to 300.00 %	1m	
59	SCALE OUTPUT	SETPOINT SCALE	INT	xxx.xx %f	1n	Output
60	SLEW ENABLE	SLEW RATE LIMIT	BOOL	FALSE / TRUE	1o	
61	SLEW DECEL LIMIT	SLEW RATE LIMIT	INT	12.0 to 1200.0 Hz/s	1p	
62	SLEW ACCEL LIMIT	SLEW RATE LIMIT	INT	12.0 to 1200.0 Hz/s	1q	
64	FULL LOAD CALIB	CURRENT FEEDBACK	INT	0.0 to 1000.0 A	1s	3, 7
65	NO LOAD CALIB	CURRENT FEEDBACK	INT	0.0 to 1000.0 A	1t	3, 7
66	MOTOR CURRENT	CURRENT FEEDBACK	INT	xxx.xh % (h)	1u	Output
67	MOTOR CURRENT	CURRENT FEEDBACK	INT	xxxx.x A	1v	Output
68	I MAGNETISING	CURRENT FEEDBACK	INT	xxx.xh % (h)	1w	Output
69	I MAGNETISING	CURRENT FEEDBACK	INT	xxxx.x A	1x	Output
70	I TORQUE	CURRENT FEEDBACK	INT	xxx.xh % (h)	1y	Output
71	I TORQUE	CURRENT FEEDBACK	INT	xxxx.x A	1z	Output
72	LOAD	CURRENT FEEDBACK	INT	xxx.xh % (h)	20	Output
73	FIELD	CURRENT FEEDBACK	INT	xxx.xh % (h)	21	Output
74	TAG NO	CUSTOM SCREEN 1	TAG	0 to 787	22	
75	DC LINK VOLTS	DYNAMIC BRAKING	INT	xxxx.x V	23	Output
77	BRAKE RESISTANCE	DYNAMIC BRAKING	INT	1 to 1000 Ohm	25	7
78	BRAKE POWER	DYNAMIC BRAKING	INT	0.1 to 510.0 kW	26	7
79	BRAKE 1S RATING	DYNAMIC BRAKING	INT	1 to 40	27	7
80	BRAKE ENABLE	DYNAMIC BRAKING	BOOL	FALSE / TRUE	28	
81	BRAKING	DYNAMIC BRAKING	BOOL	FALSE / TRUE	29	Output

# 10-4 Parameter Specification

Tag	(MMI) Name	Block	Type	Range	ID	Notes
82	SLIP ENABLE	SLIP COMP	BOOL	FALSE / TRUE	2a	7
83	NAMEPLATE RPM	SLIP COMP	INT	0 to 28800 n/min	2b	3, 7
84	MOTOR POLES	SLIP COMP	ENUM	0 : 2 1 : 4 2 : 6 3 : 8 4 : 10 5 : 12	2c	3, 7
85	SLIP MOTOR LIMIT	SLIP COMP	INT	0.0 to 600.0 n/min	2d	3
86	SLIP REGEN LIMIT	SLIP COMP	INT	0.0 to 600.0 n/min	2e	3
89	A DIN 1 INVERT	ANALOG DIGIN 1	BOOL	FALSE / TRUE	2h	
90	A DIN 1 VALUE	ANALOG DIGIN 1	BOOL	FALSE / TRUE	2i	Output
91	A DIN 1 LEVEL	ANALOG DIGIN 1	INT	0.00 to 100.00 %	2j	
92	A DIN 1 HYST	ANALOG DIGIN 1	INT	0.00 to 50.00 %	2k	
93	STARTUP SCREEN	OPERATOR MENU	INT	0 to 15	2l	
94	A DIN 2 INVERT	ANALOG DIGIN 2	BOOL	FALSE / TRUE	2m	
95	A DIN 2 VALUE	ANALOG DIGIN 2	BOOL	FALSE / TRUE	2n	Output
96	A DIN 2 LEVEL	ANALOG DIGIN 2	INT	0.00 to 100.00 %	2o	
97	A DIN 2 HYST	ANALOG DIGIN 2	INT	0.00 to 50.00 %	2p	
98	RANDOM PATTERN	PATTERN GEN	BOOL	FALSE / TRUE	2q	7
99	PATTERN GEN FREQ	PATTERN GEN	ENUM	0 : 3 kHz 1 : 6 kHz 2 : 9 kHz	2r	7
100	DEFLUX DELAY	PATTERN GEN	INT	0.1 to 10.0 s	2s	3
101	HIGH LIMIT	CUSTOM SCREEN 1	INT	-30000 to 30000	2t	
102	GROUP ID (GID)	SYSTEM PORT (P3)	INT	0 to 9	2u	
103	UNIT ID (UID)	SYSTEM PORT (P3)	INT	0 to 15	2v	
104	V/F SHAPE	FLUXING	ENUM	0 : LINEAR LAW 1 : FAN LAW	2w	7
105	V/F SCALE	FLUXING	INT	0.00 to 100.00 %	2x	7
106	BASE FREQUENCY	FLUXING	INT	7.5 to 480.0 Hz	2y	3
107	FIXED BOOST	FLUXING	INT	0.00 to 25.00 %	2z	3
108	AUTO BOOST	FLUXING	INT	0.00 to 25.00 %	30	3
112	BASE VOLTS	VOLTAGE CONTROL	INT	0.00 to 115.47 %	34	
113	LIMIT FREQUENCY	FLUXING	ENUM	0 : 120 Hz 1 : 240 Hz 2 : 480 Hz	35	7
115	OP DATABASE	OP STATION	BOOL	FALSE / TRUE	37	Output
116	AUTO BACKUP	OP STATION	BOOL	FALSE / TRUE	38	
118	VECTOR ENABLE	VECTOR FLUXING	BOOL	FALSE / TRUE	3a	7
119	STATOR RES	VECTOR FLUXING	INT	0.00 to 100.00 Ohm	3b	3, 7
120	LEAKAGE INDUC	VECTOR FLUXING	INT	0.0 to 1000.0 mH	3c	3, 7
121	MUTUAL INDUC	VECTOR FLUXING	INT	0.0 to 1000.0 mH	3d	3, 7
122	MOTOR VOLTS	VOLTAGE CONTROL	INT	198.0 to 550.0 V	3e	3
124	MOTOR CONNECTION	VECTOR FLUXING	ENUM	0 : DELTA 1 : STAR	3g	3, 7
125	FORMULA	CUSTOM SCREEN 1	ENUM	0 : A/B * X + C 1 : A/B * (X+C) 2 : A/(B * X) + C 3 : A/(B * (X+C))	3h	
126	FINAL STOP RATE	STOP	INT	12 to 4800 Hz/s	3i	
127	ENABLED KEYS	OP STATION	WORD	0000 to FFFF	3j	
128	STB ENABLE	STABILISATION	BOOL	FALSE / TRUE	3k	

# Parameter Specification 10-5

Tag	(MMI) Name	Block	Type	Range	ID	Notes
130	INPUT A	VALUE FUNC 1	INT	-300.00 to 300.00 %	3m	
131	INPUT B	VALUE FUNC 1	INT	-300.00 to 300.00 %	3n	
132	INPUT C	VALUE FUNC 1	INT	-300.00 to 300.00 %	3o	
133	OUTPUT	VALUE FUNC 1	INT	xxx.xx %	3p	Output
134	TYPE	VALUE FUNC 1	ENUM	0 : IF(C) -A 1 : ABS(A+B+C) 2 : SWITCH(A,B) 3 : (A*B)/C 4 : A+B+C 5 : A-B-C 6 : B<=A<=C 7 : A>B+/-C 8 : A>=B 9 : ABS(A)>B+/-C 10 : ABS(A)>=B 11 : A(1+B) 12 : IF(C) HOLD(A) 13 : BINARY DECODE 14 : ON DELAY 15 : OFF DELAY 16 : TIMER 17 : MINIMUM PULSE 18 : PULSE TRAIN 19 : WINDOW 20 : UP/DWN COUNTER 21 : (A*B)/C ROUND 22 : WINDOW NO HYST	3q	
135	INPUT A	VALUE FUNC 2	INT	-300.00 to 300.00 %	3r	
136	INPUT B	VALUE FUNC 2	INT	-300.00 to 300.00 %	3s	
137	INPUT C	VALUE FUNC 2	INT	-300.00 to 300.00 %	3t	
138	OUTPUT	VALUE FUNC 2	INT	xxx.xx %	3u	Output
139	TYPE	VALUE FUNC 2	ENUM	Same as tag 134	3v	
140	INPUT A	VALUE FUNC 3	INT	-300.00 to 300.00 %	3w	
141	INPUT B	VALUE FUNC 3	INT	-300.00 to 300.00 %	3x	
142	INPUT C	VALUE FUNC 3	INT	-300.00 to 300.00 %	3y	
143	OUTPUT	VALUE FUNC 3	INT	xxx.xx %	3z	Output
144	TYPE	VALUE FUNC 3	ENUM	Same as tag 134	40	
145	INPUT A	VALUE FUNC 4	INT	-300.00 to 300.00 %	41	
146	INPUT B	VALUE FUNC 4	INT	-300.00 to 300.00 %	42	
147	INPUT C	VALUE FUNC 4	INT	-300.00 to 300.00 %	43	
148	OUTPUT	VALUE FUNC 4	INT	xxx.xx %	44	Output
149	TYPE	VALUE FUNC 4	ENUM	Same as tag 134	45	
150	INPUT A	VALUE FUNC 5	INT	-300.00 to 300.00 %	46	
151	INPUT B	VALUE FUNC 5	INT	-300.00 to 300.00 %	47	
152	INPUT C	VALUE FUNC 5	INT	-300.00 to 300.00 %	48	
153	OUTPUT	VALUE FUNC 5	INT	xxx.xx %	49	Output
154	TYPE	VALUE FUNC 5	ENUM	Same as tag 134	4a	
155	INPUT A	VALUE FUNC 6	INT	-300.00 to 300.00 %	4b	
156	INPUT B	VALUE FUNC 6	INT	-300.00 to 300.00 %	4c	
157	INPUT C	VALUE FUNC 6	INT	-300.00 to 300.00 %	4d	
158	OUTPUT	VALUE FUNC 6	INT	xxx.xx %	4e	Output
159	TYPE	VALUE FUNC 6	ENUM	Same as tag 134	4f	
160	INPUT A	VALUE FUNC 7	INT	-300.00 to 300.00 %	4g	
161	INPUT B	VALUE FUNC 7	INT	-300.00 to 300.00 %	4h	
162	INPUT C	VALUE FUNC 7	INT	-300.00 to 300.00 %	4i	
163	OUTPUT	VALUE FUNC 7	INT	xxx.xx %	4j	Output

# 10-6 Parameter Specification

Tag	(MMI) Name	Block	Type	Range	ID	Notes
164	TYPE	VALUE FUNC 7	ENUM	Same as tag 134	4k	
165	INPUT A	VALUE FUNC 8	INT	-300.00 to 300.00 %	4l	
166	INPUT B	VALUE FUNC 8	INT	-300.00 to 300.00 %	4m	
167	INPUT C	VALUE FUNC 8	INT	-300.00 to 300.00 %	4n	
168	OUTPUT	VALUE FUNC 8	INT	xxx.xx %	4o	Output
169	TYPE	VALUE FUNC 8	ENUM	Same as tag 134	4p	
170	INPUT A	VALUE FUNC 9	INT	-300.00 to 300.00 %	4q	
171	INPUT B	VALUE FUNC 9	INT	-300.00 to 300.00 %	4r	
172	INPUT C	VALUE FUNC 9	INT	-300.00 to 300.00 %	4s	
173	OUTPUT	VALUE FUNC 9	INT	xxx.xx %	4t	Output
174	TYPE	VALUE FUNC 9	ENUM	Same as tag 134	4u	
175	INPUT A	VALUE FUNC 10	INT	-300.00 to 300.00 %	4v	
176	INPUT B	VALUE FUNC 10	INT	-300.00 to 300.00 %	4w	
177	INPUT C	VALUE FUNC 10	INT	-300.00 to 300.00 %	4x	
178	OUTPUT	VALUE FUNC 10	INT	xxx.xx %	4y	Output
179	TYPE	VALUE FUNC 10	ENUM	Same as tag 134	4z	
180	INPUT A	LOGIC FUNC 1	BOOL	FALSE / TRUE	50	
181	INPUT B	LOGIC FUNC 1	BOOL	FALSE / TRUE	51	
182	INPUT C	LOGIC FUNC 1	BOOL	FALSE / TRUE	52	
183	OUTPUT	LOGIC FUNC 1	BOOL	FALSE / TRUE	53	Output
184	TYPE	LOGIC FUNC 1	ENUM	0 : NOT(A) 1 : AND(A,B,C) 2 : NAND(A,B,C) 3 : OR(A,B,C) 4 : NOR(A,B,C) 5 : XOR(A,B) 6 : 0-1 EDGE(A) 7 : 1-0 EDGE(A) 8 : AND(A,B,!C) 9 : OR(A,B,!C) 10 : S FLIP-FLOP 11 : R FLIP-FLOP	54	
185	INPUT A	LOGIC FUNC 2	BOOL	FALSE / TRUE	55	
186	INPUT B	LOGIC FUNC 2	BOOL	FALSE / TRUE	56	
187	INPUT C	LOGIC FUNC 2	BOOL	FALSE / TRUE	57	
188	OUTPUT	LOGIC FUNC 2	BOOL	FALSE / TRUE	58	Output
189	TYPE	LOGIC FUNC 2	ENUM	Same as tag 184	59	
190	INPUT A	LOGIC FUNC 3	BOOL	FALSE / TRUE	5a	
191	INPUT B	LOGIC FUNC 3	BOOL	FALSE / TRUE	5b	
192	INPUT C	LOGIC FUNC 3	BOOL	FALSE / TRUE	5c	
193	OUTPUT	LOGIC FUNC 3	BOOL	FALSE / TRUE	5d	Output
194	TYPE	LOGIC FUNC 3	ENUM	Same as tag 184	5e	
195	INPUT A	LOGIC FUNC 4	BOOL	FALSE / TRUE	5f	
196	INPUT B	LOGIC FUNC 4	BOOL	FALSE / TRUE	5g	
197	INPUT C	LOGIC FUNC 4	BOOL	FALSE / TRUE	5h	
198	OUTPUT	LOGIC FUNC 4	BOOL	FALSE / TRUE	5i	Output
199	TYPE	LOGIC FUNC 4	ENUM	Same as tag 184	5j	
200	INPUT A	LOGIC FUNC 5	BOOL	FALSE / TRUE	5k	
201	INPUT B	LOGIC FUNC 5	BOOL	FALSE / TRUE	5l	
202	INPUT C	LOGIC FUNC 5	BOOL	FALSE / TRUE	5m	
203	OUTPUT	LOGIC FUNC 5	BOOL	FALSE / TRUE	5n	Output
204	TYPE	LOGIC FUNC 5	ENUM	Same as tag 184	5o	

# Parameter Specification 10-7

Tag	(MMI) Name	Block	Type	Range	ID	Notes
205	INPUT A	LOGIC FUNC 6	BOOL	FALSE / TRUE	5p	
206	INPUT B	LOGIC FUNC 6	BOOL	FALSE / TRUE	5q	
207	INPUT C	LOGIC FUNC 6	BOOL	FALSE / TRUE	5r	
208	OUTPUT	LOGIC FUNC 6	BOOL	FALSE / TRUE	5s	Output
209	TYPE	LOGIC FUNC 6	ENUM	Same as tag 184	5t	
210	INPUT A	LOGIC FUNC 7	BOOL	FALSE / TRUE	5u	
211	INPUT B	LOGIC FUNC 7	BOOL	FALSE / TRUE	5v	
212	INPUT C	LOGIC FUNC 7	BOOL	FALSE / TRUE	5w	
213	OUTPUT	LOGIC FUNC 7	BOOL	FALSE / TRUE	5x	Output
214	TYPE	LOGIC FUNC 7	ENUM	Same as tag 184	5y	
215	INPUT A	LOGIC FUNC 8	BOOL	FALSE / TRUE	5z	
216	INPUT B	LOGIC FUNC 8	BOOL	FALSE / TRUE	60	
217	INPUT C	LOGIC FUNC 8	BOOL	FALSE / TRUE	61	
218	OUTPUT	LOGIC FUNC 8	BOOL	FALSE / TRUE	62	Output
219	TYPE	LOGIC FUNC 8	ENUM	Same as tag 184	63	
220	INPUT A	LOGIC FUNC 9	BOOL	FALSE / TRUE	64	
221	INPUT B	LOGIC FUNC 9	BOOL	FALSE / TRUE	65	
222	INPUT C	LOGIC FUNC 9	BOOL	FALSE / TRUE	66	
223	OUTPUT	LOGIC FUNC 9	BOOL	FALSE / TRUE	67	Output
224	TYPE	LOGIC FUNC 9	ENUM	Same as tag 184	68	
225	INPUT A	LOGIC FUNC 10	BOOL	FALSE / TRUE	69	
226	INPUT B	LOGIC FUNC 10	BOOL	FALSE / TRUE	6a	
227	INPUT C	LOGIC FUNC 10	BOOL	FALSE / TRUE	6b	
228	OUTPUT	LOGIC FUNC 10	BOOL	FALSE / TRUE	6c	Output
229	TYPE	LOGIC FUNC 10	ENUM	Same as tag 184	6d	
230	OP VERSION	OP STATION	WORD	0000 to FFFF	6e	Output
231	DISABLED TRIPS	TRIPS STATUS	WORD	0000 to FFFF	6f	
234	EXTERNAL TRIP	I/O TRIPS	BOOL	FALSE / TRUE	6i	1
235	INPUT 1 BREAK	I/O TRIPS	BOOL	FALSE / TRUE	6j	1
236	INPUT 2 BREAK	I/O TRIPS	BOOL	FALSE / TRUE	6k	1
237	I*T THRESHOLD	I*T TRIP	INT	50.00 to 105.00 %	6l	
238	I*T TIME	I*T TRIP	USINT	5 to 60 s	6m	
239	I*T UPPER LIMIT	I*T TRIP	INT	50.00 to 150.00 %	6n	
240	STALL LIMIT	STALL TRIP	INT	50.00 to 150.00 %	6o	
241	STALL TIME	STALL TRIP	INT	0.1 to 3000.0 s	6p	
242	POWER FACTOR	CURRENT FEEDBACK	USINT	0.50 to 0.95	6q	3, 7
243	TRIM IN LOCAL	REFERENCE	BOOL	FALSE / TRUE	6r	
244	RAMP TYPE	SYSTEM RAMP	ENUM	0 : LINEAR 1 : S	6s	
245	REMOTE SETPOINT	REFERENCE	INT	-300.00 to 300.00 %	6t	
246	JOG SETPOINT	JOG	INT	0.00 to 100.00 %	6u	
247	LOCAL SETPOINT	REFERENCE	INT	0.00 to 100.00 %	6v	Output, 2
248	SPEED TRIM	REFERENCE	INT	-300.00 to 300.00 %	6w	
249	REMOTE REVERSE	REFERENCE	BOOL	FALSE / TRUE	6x	
250	LOCAL REVERSE	REFERENCE	BOOL	FALSE / TRUE	6y	Output, 2
252	MAX SPEED CLAMP	REFERENCE	INT	0.00 to 100.00 %	70	
253	MIN SPEED CLAMP	REFERENCE	INT	-100.00 to 0.00 %	71	
254	SPEED SETPOINT	REFERENCE	INT	xxx.xh % (h)	72	Output

# 10-8 Parameter Specification

Tag	(MMI) Name	Block	Type	Range	ID	Notes
255	SPEED DEMAND	REFERENCE	INT	xxx.xh % (h)	73	Output
256	REVERSE	REFERENCE	BOOL	FALSE / TRUE	74	Output
257	REMOTE REF	LOCAL CONTROL	BOOL	FALSE / TRUE	75	Output
258	RAMP ACCEL RATE	SYSTEM RAMP	INT	0.0 to 600.0 s	76	
259	RAMP DECEL RATE	SYSTEM RAMP	INT	0.0 to 600.0 s	77	
260	RAMP HOLD	SYSTEM RAMP	BOOL	FALSE / TRUE	78	
261	JOG ACCEL RATE	JOG	INT	0.0 to 600.0 s	79	
262	JOG DECEL RATE	JOG	INT	0.0 to 600.0 s	7a	
263	STOP RATE	STOP	INT	0.0 to 600.0 s	7b	
264	FAST STOP RATE	STOP	INT	0.0 to 600.0 s	7c	
265	REF MODES	LOCAL CONTROL	ENUM	0 : LOCAL/REMOTE 1 : LOCAL ONLY 2 : REMOTE ONLY	7d	7
266	STOP ZERO SPEED	STOP	INT	0.00 to 100.00 %	7e	
267	RAMP SYM RATE	SYSTEM RAMP	INT	0.0 to 600.0 s	7f	
268	RAMP SYM MODE	SYSTEM RAMP	BOOL	FALSE / TRUE	7g	
269	COMMS SETPOINT	REFERENCE	INT	-300.00 to 300.00 %	7h	1, 4, 5
270	COMMS REF	COMMS CONTROL	BOOL	FALSE / TRUE	7i	Output
272	COMMS STATUS	COMMS CONTROL	WORD	0000 to FFFF	7k	Output
273	COMMS COMMAND	COMMS CONTROL	WORD	0000 to FFFF	7l	Output
274	HEALTHY	SEQUENCING LOGIC	BOOL	FALSE / TRUE	7m	Output
275	FAST STOP LIMIT	STOP	INT	0.0 to 3000.0 s	7n	
276	DRIVE ENABLE	SEQUENCING LOGIC	BOOL	FALSE / TRUE	7o	
277	/FAST STOP	SEQUENCING LOGIC	BOOL	FALSE / TRUE	7p	
278	/COAST STOP	SEQUENCING LOGIC	BOOL	FALSE / TRUE	7q	
279	RUN STOP MODE	STOP	ENUM	0 : RAMPED 1 : COAST 2 : DC INJECTION	7r	7
280	JOG	SEQUENCING LOGIC	BOOL	FALSE / TRUE	7s	1
281	SEQ DIRECTION	LOCAL CONTROL	BOOL	FALSE / TRUE	7t	7
282	REM TRIP RESET	SEQUENCING LOGIC	BOOL	FALSE / TRUE	7u	1
283	POWER UP START	SEQUENCING LOGIC	BOOL	FALSE / TRUE	7v	
284	STOP DELAY	STOP	INT	0.000 to 30.000 s	7w	
285	RUNNING	SEQUENCING LOGIC	BOOL	FALSE / TRUE	7x	Output
286	OUTPUT CONTACTOR	SEQUENCING LOGIC	BOOL	FALSE / TRUE	7y	Output
287	READY	SEQUENCING LOGIC	BOOL	FALSE / TRUE	7z	Output
288	SWITCH ON ENABLE	SEQUENCING LOGIC	BOOL	FALSE / TRUE	80	Output
289	TRIPPED	SEQUENCING LOGIC	BOOL	FALSE / TRUE	81	Output
290	TRIP RST BY RUN	SEQUENCING LOGIC	BOOL	FALSE / TRUE	82	
291	RUN FWD	SEQUENCING LOGIC	BOOL	FALSE / TRUE	83	1
292	RUN REV	SEQUENCING LOGIC	BOOL	FALSE / TRUE	84	1
293	/STOP	SEQUENCING LOGIC	BOOL	FALSE / TRUE	85	1
294	REMOTE REVERSE	SEQUENCING LOGIC	BOOL	FALSE / TRUE	86	
295	COMMS SEQ	COMMS CONTROL	BOOL	FALSE / TRUE	87	Output
296	REMOTE REV OUT	SEQUENCING LOGIC	BOOL	FALSE / TRUE	88	Output
297	REMOTE SEQ	LOCAL CONTROL	BOOL	FALSE / TRUE	89	Output
298	SEQ MODES	LOCAL CONTROL	ENUM	Same as tag 265	8a	7
299	POWER UP MODE	LOCAL CONTROL	ENUM	0 : LOCAL 1 : REMOTE 2 : AUTOMATIC	8b	

# Parameter Specification 10-9

Tag	(MMI) Name	Block	Type	Range	ID	Notes
300	REMOTE COMMS SEL	COMMS CONTROL	BOOL	FALSE / TRUE	8c	7
301	MAIN SEQ STATE	SEQUENCING LOGIC	ENUM	0 : NOT READY 1 : START DISABLED 2 : START ENABLED 3 : SWITCHED ON 4 : ENABLED 5 : F-STOP ACTIVE 6 : TRIP ACTIVE 7 : TRIPPED	8d	Output
302	JOGGING	SEQUENCING LOGIC	BOOL	FALSE / TRUE	8e	Output
303	STOPPING	SEQUENCING LOGIC	BOOL	FALSE / TRUE	8f	Output
304	FAST STOP MODE	STOP	ENUM	0 : RAMPED 1 : COAST	8g	7
305	SYSTEM RESET	SEQUENCING LOGIC	BOOL	FALSE / TRUE	8h	Output
306	SWITCHED ON	SEQUENCING LOGIC	BOOL	FALSE / TRUE	8i	Output
307	REMOTE SEQ MODES	COMMS CONTROL	ENUM	0 : TERMINALS/COMMS 1 : TERMINALS ONLY 2 : COMMS ONLY	8j	7
308	REMOTE REF MODES	COMMS CONTROL	ENUM	Same as tag 307	8k	7
309	COMMS TIMEOUT	COMMS CONTROL	INT	0.0 to 600.0 s	8l	
310	PID SETPOINT	PID	INT	-300.00 to 300.00 %	8m	
311	PID ENABLE	PID	BOOL	FALSE / TRUE	8n	
312	PID INTEGRAL OFF	PID	BOOL	FALSE / TRUE	8o	
313	PID P GAIN	PID	INT	0.0 to 100.0	8p	
314	PID I TIME CONST	PID	INT	0.01 to 100.00 s	8q	
315	PID D TIME CONST	PID	INT	0.000 to 10.000 s	8r	
316	PID FILTER TC	PID	INT	0.000 to 10.000 s	8s	
317	PID OUT POS LIM	PID	INT	0.00 to 105.00 %	8t	
318	PID OUT NEG LIM	PID	INT	-105.00 to 0.00 %	8u	
319	PID OUT SCALING	PID	INT	-3.0000 to 3.0000	8v	
320	PID OUTPUT	PID	INT	xxx.xx %	8w	Output
321	COEFFICIENT A	CUSTOM SCREEN 1	INT	-30000 to 30000	8x	
322	COEFFICIENT C	CUSTOM SCREEN 1	INT	-30000 to 30000	8y	
323	UNITS	CUSTOM SCREEN 1	STRING	5 characters	8z	5, 6
324	NAME	CUSTOM SCREEN 1	STRING	16 characters	90	5, 6
325	RAISE/LOWER OUT	RAISE/LOWER	INT	xxx.xx %	91	Output, 2
326	RL RAMP RATE	RAISE/LOWER	INT	0.0 to 600.0 s	92	
327	RAISE INPUT	RAISE/LOWER	BOOL	FALSE / TRUE	93	
328	LOWER INPUT	RAISE/LOWER	BOOL	FALSE / TRUE	94	
329	RL MIN VALUE	RAISE/LOWER	INT	-300.00 to 300.00 %	95	
330	RL MAX VALUE	RAISE/LOWER	INT	-300.00 to 300.00 %	96	
331	RL RESET VALUE	RAISE/LOWER	INT	-300.00 to 300.00 %	97	
332	RL RESET	RAISE/LOWER	BOOL	FALSE / TRUE	98	
334	DECIMAL PLACE	CUSTOM SCREEN 1	ENUM	0 : XXXXX. 1 : XXXX.X 2 : XXX.XX 3 : XX.XXX 4 : X.XXXX 5 : XXXX. 6 : XXX.X_ 7 : XX.XX_ 8 : X.XXX_	9a	
335	MIN SPEED OUTPUT	MINIMUM SPEED	INT	xxx.xx %	9b	Output
336	MIN SPEED INPUT	MINIMUM SPEED	INT	-300.00 to 300.00 %	9c	
337	MIN SPEED	MINIMUM SPEED	INT	-100.00 to 100.00 %	9d	

# 10-10 Parameter Specification

Tag	(MMI) Name	Block	Type	Range	ID	Notes
338	MIN SPEED MODE	MINIMUM SPEED	ENUM	0 : PROP. W/MIN. 1 : LINEAR	9e	
339	CONFIGURATION ID	OP STATION	STRING	16 characters	9f	5, 6
340	SKIP FREQ INPUT	SKIP FREQUENCIES	INT	-300.00 to 300.00 %	9g	
341	SKIP FREQ BAND 1	SKIP FREQUENCIES	INT	0.0 to 480.0 Hz	9h	
342	SKIP FREQUENCY 1	SKIP FREQUENCIES	INT	0.0 to 480.0 Hz	9i	
343	SKIP FREQUENCY 2	SKIP FREQUENCIES	INT	0.0 to 480.0 Hz	9j	
344	SKIP FREQUENCY 3	SKIP FREQUENCIES	INT	0.0 to 480.0 Hz	9k	
345	SKIP FREQUENCY 4	SKIP FREQUENCIES	INT	0.0 to 480.0 Hz	9l	
346	SKIP FREQ OUTPUT	SKIP FREQUENCIES	INT	xxx.xx %	9m	Output
347	PRESET 1 INPUT 0	PRESET 1	INT	-300.00 to 300.00 %	9n	
348	PRESET 1 INPUT 1	PRESET 1	INT	-300.00 to 300.00 %	9o	
349	PRESET 1 INPUT 2	PRESET 1	INT	-300.00 to 300.00 %	9p	
350	PRESET 1 INPUT 3	PRESET 1	INT	-300.00 to 300.00 %	9q	
351	PRESET 1 INPUT 4	PRESET 1	INT	-300.00 to 300.00 %	9r	
352	PRESET 1 INPUT 5	PRESET 1	INT	-300.00 to 300.00 %	9s	
353	PRESET 1 INPUT 6	PRESET 1	INT	-300.00 to 300.00 %	9t	
354	PRESET 1 INPUT 7	PRESET 1	INT	-300.00 to 300.00 %	9u	
355	PRESET 1 SELECT	PRESET 1	ENUM	0 : INPUT 0 1 : INPUT 1 2 : INPUT 2 3 : INPUT 3 4 : INPUT 4 5 : INPUT 5 6 : INPUT 6 7 : INPUT 7	9v	
356	PRESET 1 OUTPUT1	PRESET 1	INT	xxx.xx %	9w	Output
357	ZERO SPEED LEVEL	ZERO SPEED	INT	0.00 to 100.00 %	9x	
358	ZERO SPEED IN	ZERO SPEED	INT	-300.00 to 300.00 %	9y	
359	ZERO SPEED BAND	ZERO SPEED	INT	-300.00 to 300.00 %	9z	
360	AT ZERO SPEED	ZERO SPEED	BOOL	FALSE / TRUE	a0	Output
361	PROTECT LOCAL SP	PASSWORD	BOOL	FALSE / TRUE	a1	
362	SKIP FREQ INPUT	SKIP FREQUENCIES	INT	xxxx.x Hz	a2	Output
363	SKIP FREQ OUTPUT	SKIP FREQUENCIES	INT	xxxx.x Hz	a3	Output
364	PROTECT OP MENU	PASSWORD	BOOL	FALSE / TRUE	a4	
365	MOTOR 1 LIMIT	CURRENT LIMIT	INT	0.00 to 150.00 %	a5	
366	FEEDBACK SOURCE	CURRENT LIMIT	ENUM	0 : CURRENT 1 : LOAD	a6	7
370	CURRENT LIMITING	CURRENT LIMIT	BOOL	FALSE / TRUE	aa	Output
371	TAG NO	CUSTOM SCREEN 2	TAG	0 to 787	ab	
372	PRESET 1 OUTPUT2	PRESET 1	INT	xxx.xx %	ac	Output
373	PRESET 2 OUTPUT2	PRESET 2	INT	xxx.xx %	ad	Output
374	PRESET 3 OUTPUT2	PRESET 3	INT	xxx.xx %	ae	Output
375	COEFFICIENT A	CUSTOM SCREEN 2	INT	-30000 to 30000	af	
376	COEFFICIENT C	CUSTOM SCREEN 2	INT	-30000 to 30000	ag	
377	UNITS	CUSTOM SCREEN 2	STRING	5 characters	ah	5, 6
378	NAME	CUSTOM SCREEN 2	STRING	16 characters	ai	5, 6
379	DECIMAL PLACE	CUSTOM SCREEN 2	ENUM	Same as tag 334	aj	
380	PRESET 2 INPUT 0	PRESET 2	INT	-300.00 to 300.00 %	ak	
381	PRESET 2 INPUT 1	PRESET 2	INT	-300.00 to 300.00 %	al	
382	PRESET 2 INPUT 2	PRESET 2	INT	-300.00 to 300.00 %	am	

Tag	(MMI) Name	Block	Type	Range	ID	Notes
383	PRESET 2 INPUT 3	PRESET 2	INT	-300.00 to 300.00 %	an	
384	PRESET 2 INPUT 4	PRESET 2	INT	-300.00 to 300.00 %	ao	
385	PRESET 2 INPUT 5	PRESET 2	INT	-300.00 to 300.00 %	ap	
386	PRESET 2 INPUT 6	PRESET 2	INT	-300.00 to 300.00 %	aq	
387	PRESET 2 INPUT 7	PRESET 2	INT	-300.00 to 300.00 %	ar	
388	PRESET 2 SELECT	PRESET 2	ENUM	Same as tag 355	as	
389	PRESET 2 OUTPUT1	PRESET 2	INT	xxx.xx %	at	Output
390	PRESET 3 INPUT 0	PRESET 3	INT	-300.00 to 300.00 %	au	
391	PRESET 3 INPUT 1	PRESET 3	INT	-300.00 to 300.00 %	av	
392	PRESET 3 INPUT 2	PRESET 3	INT	-300.00 to 300.00 %	aw	
393	PRESET 3 INPUT 3	PRESET 3	INT	-300.00 to 300.00 %	ax	
394	PRESET 3 INPUT 4	PRESET 3	INT	-300.00 to 300.00 %	ay	
395	PRESET 3 INPUT 5	PRESET 3	INT	-300.00 to 300.00 %	az	
396	PRESET 3 INPUT 6	PRESET 3	INT	-300.00 to 300.00 %	b0	
397	PRESET 3 INPUT 7	PRESET 3	INT	-300.00 to 300.00 %	b1	
398	PRESET 3 SELECT	PRESET 3	ENUM	Same as tag 355	b2	
399	PRESET 3 OUTPUT1	PRESET 3	INT	xxx.xx %	b3	Output
400	SOURCE 1	LINKS	S_TAG	-787 to 787	b4	5, 6, 8
401	DESTINATION 1	LINKS	D_TAG	0 to 787	b5	5, 6, 8
402	SOURCE 2	LINKS	S_TAG	-787 to 787	b6	5, 6, 8
403	DESTINATION 2	LINKS	D_TAG	0 to 787	b7	5, 6, 8
404	SOURCE 3	LINKS	S_TAG	-787 to 787	b8	5, 6, 8
405	DESTINATION 3	LINKS	D_TAG	0 to 787	b9	5, 6, 8
406	SOURCE 4	LINKS	S_TAG	-787 to 787	ba	5, 6, 8
407	DESTINATION 4	LINKS	D_TAG	0 to 787	bb	5, 6, 8
408	SOURCE 5	LINKS	S_TAG	-787 to 787	bc	5, 6, 8
409	DESTINATION 5	LINKS	D_TAG	0 to 787	bd	5, 6, 8
410	SOURCE 6	LINKS	S_TAG	-787 to 787	be	5, 6, 8
411	DESTINATION 6	LINKS	D_TAG	0 to 787	bf	5, 6, 8
412	SOURCE 7	LINKS	S_TAG	-787 to 787	bg	5, 6, 8
413	DESTINATION 7	LINKS	D_TAG	0 to 787	bh	5, 6, 8
414	SOURCE 8	LINKS	S_TAG	-787 to 787	bi	5, 6, 8
415	DESTINATION 8	LINKS	D_TAG	0 to 787	bj	5, 6, 8
416	SOURCE 9	LINKS	S_TAG	-787 to 787	bk	5, 6, 8
417	DESTINATION 9	LINKS	D_TAG	0 to 787	bl	5, 6, 8
418	SOURCE 10	LINKS	S_TAG	-787 to 787	bm	5, 6, 8
419	DESTINATION 10	LINKS	D_TAG	0 to 787	bn	5, 6, 8
420	SOURCE 11	LINKS	S_TAG	-787 to 787	bo	5, 6, 8
421	DESTINATION 11	LINKS	D_TAG	0 to 787	bp	5, 6, 8
422	SOURCE 12	LINKS	S_TAG	-787 to 787	bq	5, 6, 8
423	DESTINATION 12	LINKS	D_TAG	0 to 787	br	5, 6, 8
424	SOURCE 13	LINKS	S_TAG	-787 to 787	bs	5, 6, 8
425	DESTINATION 13	LINKS	D_TAG	0 to 787	bt	5, 6, 8
426	SOURCE 14	LINKS	S_TAG	-787 to 787	bu	5, 6, 8
427	DESTINATION 14	LINKS	D_TAG	0 to 787	bv	5, 6, 8
428	SOURCE 15	LINKS	S_TAG	-787 to 787	bw	5, 6, 8
429	DESTINATION 15	LINKS	D_TAG	0 to 787	bx	5, 6, 8
430	SOURCE 16	LINKS	S_TAG	-787 to 787	by	5, 6, 8

# 10-12 Parameter Specification

Tag	(MMI) Name	Block	Type	Range	ID	Notes
431	DESTINATION 16	LINKS	D_TAG	0 to 787	bz	5, 6, 8
432	SOURCE 17	LINKS	S_TAG	-787 to 787	c0	5, 6, 8
433	DESTINATION 17	LINKS	D_TAG	0 to 787	c1	5, 6, 8
434	SOURCE 18	LINKS	S_TAG	-787 to 787	c2	5, 6, 8
435	DESTINATION 18	LINKS	D_TAG	0 to 787	c3	5, 6, 8
436	SOURCE 19	LINKS	S_TAG	-787 to 787	c4	5, 6, 8
437	DESTINATION 19	LINKS	D_TAG	0 to 787	c5	5, 6, 8
438	SOURCE 20	LINKS	S_TAG	-787 to 787	c6	5, 6, 8
439	DESTINATION 20	LINKS	D_TAG	0 to 787	c7	5, 6, 8
440	SOURCE 21	LINKS	S_TAG	-787 to 787	c8	5, 6, 8
441	DESTINATION 21	LINKS	D_TAG	0 to 787	c9	5, 6, 8
442	SOURCE 22	LINKS	S_TAG	-787 to 787	ca	5, 6, 8
443	DESTINATION 22	LINKS	D_TAG	0 to 787	cb	5, 6, 8
444	SOURCE 23	LINKS	S_TAG	-787 to 787	cc	5, 6, 8
445	DESTINATION 23	LINKS	D_TAG	0 to 787	cd	5, 6, 8
446	SOURCE 24	LINKS	S_TAG	-787 to 787	ce	5, 6, 8
447	DESTINATION 24	LINKS	D_TAG	0 to 787	cf	5, 6, 8
448	SOURCE 25	LINKS	S_TAG	-787 to 787	cg	5, 6, 8
449	DESTINATION 25	LINKS	D_TAG	0 to 787	ch	5, 6, 8
450	SOURCE 26	LINKS	S_TAG	-787 to 787	ci	5, 6, 8
451	DESTINATION 26	LINKS	D_TAG	0 to 787	cj	5, 6, 8
452	SOURCE 27	LINKS	S_TAG	-787 to 787	ck	5, 6, 8
453	DESTINATION 27	LINKS	D_TAG	0 to 787	cl	5, 6, 8
454	SOURCE 28	LINKS	S_TAG	-787 to 787	cm	5, 6, 8
455	DESTINATION 28	LINKS	D_TAG	0 to 787	cn	5, 6, 8
456	SOURCE 29	LINKS	S_TAG	-787 to 787	co	5, 6, 8
457	DESTINATION 29	LINKS	D_TAG	0 to 787	cp	5, 6, 8
458	SOURCE 30	LINKS	S_TAG	-787 to 787	cq	5, 6, 8
459	DESTINATION 30	LINKS	D_TAG	0 to 787	cr	5, 6, 8
460	SOURCE 31	LINKS	S_TAG	-787 to 787	cs	5, 6, 8
461	DESTINATION 31	LINKS	D_TAG	0 to 787	ct	5, 6, 8
462	SOURCE 32	LINKS	S_TAG	-787 to 787	cu	5, 6, 8
463	DESTINATION 32	LINKS	D_TAG	0 to 787	cv	5, 6, 8
464	SOURCE 33	LINKS	S_TAG	-787 to 787	cw	5, 6, 8
465	DESTINATION 33	LINKS	D_TAG	0 to 787	cx	5, 6, 8
466	SOURCE 34	LINKS	S_TAG	-787 to 787	cy	5, 6, 8
467	DESTINATION 34	LINKS	D_TAG	0 to 787	cz	5, 6, 8
468	SOURCE 35	LINKS	S_TAG	-787 to 787	d0	5, 6, 8
469	DESTINATION 35	LINKS	D_TAG	0 to 787	d1	5, 6, 8
470	SOURCE 36	LINKS	S_TAG	-787 to 787	d2	5, 6, 8
471	DESTINATION 36	LINKS	D_TAG	0 to 787	d3	5, 6, 8
472	SOURCE 37	LINKS	S_TAG	-787 to 787	d4	5, 6, 8
473	DESTINATION 37	LINKS	D_TAG	0 to 787	d5	5, 6, 8
474	SOURCE 38	LINKS	S_TAG	-787 to 787	d6	5, 6, 8
475	DESTINATION 38	LINKS	D_TAG	0 to 787	d7	5, 6, 8
476	SOURCE 39	LINKS	S_TAG	-787 to 787	d8	5, 6, 8
477	DESTINATION 39	LINKS	D_TAG	0 to 787	d9	5, 6, 8
478	SOURCE 40	LINKS	S_TAG	-787 to 787	da	5, 6, 8

# Parameter Specification 10-13

Tag	(MMI) Name	Block	Type	Range	ID	Notes
479	DESTINATION 40	LINKS	D_TAG	0 to 787	db	5, 6, 8
480	SOURCE 41	LINKS	S_TAG	-787 to 787	dc	5, 6, 8
481	DESTINATION 41	LINKS	D_TAG	0 to 787	dd	5, 6, 8
482	SOURCE 42	LINKS	S_TAG	-787 to 787	de	5, 6, 8
483	DESTINATION 42	LINKS	D_TAG	0 to 787	df	5, 6, 8
484	SOURCE 43	LINKS	S_TAG	-787 to 787	dg	5, 6, 8
485	DESTINATION 43	LINKS	D_TAG	0 to 787	dh	5, 6, 8
486	SOURCE 44	LINKS	S_TAG	-787 to 787	di	5, 6, 8
487	DESTINATION 44	LINKS	D_TAG	0 to 787	dj	5, 6, 8
488	SOURCE 45	LINKS	S_TAG	-787 to 787	dk	5, 6, 8
489	DESTINATION 45	LINKS	D_TAG	0 to 787	dl	5, 6, 8
490	SOURCE 46	LINKS	S_TAG	-787 to 787	dm	5, 6, 8
491	DESTINATION 46	LINKS	D_TAG	0 to 787	dn	5, 6, 8
492	SOURCE 47	LINKS	S_TAG	-787 to 787	do	5, 6, 8
493	DESTINATION 47	LINKS	D_TAG	0 to 787	dp	5, 6, 8
494	SOURCE 48	LINKS	S_TAG	-787 to 787	dq	5, 6, 8
495	DESTINATION 48	LINKS	D_TAG	0 to 787	dr	5, 6, 8
496	SOURCE 49	LINKS	S_TAG	-787 to 787	ds	5, 6, 8
497	DESTINATION 49	LINKS	D_TAG	0 to 787	dt	5, 6, 8
498	SOURCE 50	LINKS	S_TAG	-787 to 787	du	5, 6, 8
499	DESTINATION 50	LINKS	D_TAG	0 to 787	dv	5, 6, 8
500	TRIP 1 (NEWEST)	TRIPS HISTORY	ENUM	Same as tag 6	dw	Output, 2
501	TRIP 2	TRIPS HISTORY	ENUM	Same as tag 6	dx	Output, 2
502	TRIP 3	TRIPS HISTORY	ENUM	Same as tag 6	dy	Output, 2
503	TRIP 4	TRIPS HISTORY	ENUM	Same as tag 6	dz	Output, 2
504	TRIP 5	TRIPS HISTORY	ENUM	Same as tag 6	e0	Output, 2
505	TRIP 6	TRIPS HISTORY	ENUM	Same as tag 6	e1	Output, 2
506	TRIP 7	TRIPS HISTORY	ENUM	Same as tag 6	e2	Output, 2
507	TRIP 8	TRIPS HISTORY	ENUM	Same as tag 6	e3	Output, 2
508	TRIP 9	TRIPS HISTORY	ENUM	Same as tag 6	e4	Output, 2
509	TRIP 10 (OLDEST)	TRIPS HISTORY	ENUM	Same as tag 6	e5	Output, 2
510	PRESET 4 INPUT 0	PRESET 4	INT	-300.00 to 300.00 %	e6	
511	PRESET 4 INPUT 1	PRESET 4	INT	-300.00 to 300.00 %	e7	
512	PRESET 4 INPUT 2	PRESET 4	INT	-300.00 to 300.00 %	e8	
513	PRESET 4 INPUT 3	PRESET 4	INT	-300.00 to 300.00 %	e9	
514	PRESET 4 INPUT 4	PRESET 4	INT	-300.00 to 300.00 %	ea	
515	PRESET 4 INPUT 5	PRESET 4	INT	-300.00 to 300.00 %	eb	
516	PRESET 4 INPUT 6	PRESET 4	INT	-300.00 to 300.00 %	ec	
517	PRESET 4 INPUT 7	PRESET 4	INT	-300.00 to 300.00 %	ed	
518	PRESET 4 SELECT	PRESET 4	ENUM	Same as tag 355	ee	
519	PRESET 4 OUTPUT1	PRESET 4	INT	xxx.xx %	ef	Output
520	PRESET 4 OUTPUT2	PRESET 4	INT	xxx.xx %	eg	Output
521	PRESET 5 INPUT 0	PRESET 5	INT	-300.00 to 300.00 %	eh	
522	PRESET 5 INPUT 1	PRESET 5	INT	-300.00 to 300.00 %	ei	
523	PRESET 5 INPUT 2	PRESET 5	INT	-300.00 to 300.00 %	ej	
524	PRESET 5 INPUT 3	PRESET 5	INT	-300.00 to 300.00 %	ek	
525	PRESET 5 INPUT 4	PRESET 5	INT	-300.00 to 300.00 %	el	
526	PRESET 5 INPUT 5	PRESET 5	INT	-300.00 to 300.00 %	em	

# 10-14 Parameter Specification

Tag	(MMI) Name	Block	Type	Range	ID	Notes
527	PRESET 5 INPUT 6	PRESET 5	INT	-300.00 to 300.00 %	en	
528	PRESET 5 INPUT 7	PRESET 5	INT	-300.00 to 300.00 %	eo	
529	PRESET 5 SELECT	PRESET 5	ENUM	Same as tag 355	ep	
530	PRESET 5 OUTPUT1	PRESET 5	INT	xxx.xx %	eq	Output
531	PRESET 5 OUTPUT2	PRESET 5	INT	xxx.xx %	er	Output
532	PRESET 6 INPUT 0	PRESET 6	INT	-300.00 to 300.00 %	es	
533	PRESET 6 INPUT 1	PRESET 6	INT	-300.00 to 300.00 %	et	
534	PRESET 6 INPUT 2	PRESET 6	INT	-300.00 to 300.00 %	eu	
535	PRESET 6 INPUT 3	PRESET 6	INT	-300.00 to 300.00 %	ev	
536	PRESET 6 INPUT 4	PRESET 6	INT	-300.00 to 300.00 %	ew	
537	PRESET 6 INPUT 5	PRESET 6	INT	-300.00 to 300.00 %	ex	
538	PRESET 6 INPUT 6	PRESET 6	INT	-300.00 to 300.00 %	ey	
539	PRESET 6 INPUT 7	PRESET 6	INT	-300.00 to 300.00 %	ez	
540	PRESET 6 SELECT	PRESET 6	ENUM	Same as tag 355	f0	
541	PRESET 6 OUTPUT1	PRESET 6	INT	xxx.xx %	f1	Output
542	PRESET 6 OUTPUT2	PRESET 6	INT	xxx.xx %	f2	Output
543	PRESET 7 INPUT 0	PRESET 7	INT	-300.00 to 300.00 %	f3	
544	PRESET 7 INPUT 1	PRESET 7	INT	-300.00 to 300.00 %	f4	
545	PRESET 7 INPUT 2	PRESET 7	INT	-300.00 to 300.00 %	f5	
546	PRESET 7 INPUT 3	PRESET 7	INT	-300.00 to 300.00 %	f6	
547	PRESET 7 INPUT 4	PRESET 7	INT	-300.00 to 300.00 %	f7	
548	PRESET 7 INPUT 5	PRESET 7	INT	-300.00 to 300.00 %	f8	
549	PRESET 7 INPUT 6	PRESET 7	INT	-300.00 to 300.00 %	f9	
550	PRESET 7 INPUT 7	PRESET 7	INT	-300.00 to 300.00 %	fa	
551	PRESET 7 SELECT	PRESET 7	ENUM	Same as tag 355	fb	
552	PRESET 7 OUTPUT1	PRESET 7	INT	xxx.xx %	fc	Output
553	PRESET 7 OUTPUT2	PRESET 7	INT	xxx.xx %	fd	Output
554	PRESET 8 INPUT 0	PRESET 8	INT	-300.00 to 300.00 %	fe	
555	PRESET 8 INPUT 1	PRESET 8	INT	-300.00 to 300.00 %	ff	
556	PRESET 8 INPUT 2	PRESET 8	INT	-300.00 to 300.00 %	fg	
557	PRESET 8 INPUT 3	PRESET 8	INT	-300.00 to 300.00 %	fh	
558	PRESET 8 INPUT 4	PRESET 8	INT	-300.00 to 300.00 %	fi	
559	PRESET 8 INPUT 5	PRESET 8	INT	-300.00 to 300.00 %	fj	
560	PRESET 8 INPUT 6	PRESET 8	INT	-300.00 to 300.00 %	fk	
561	PRESET 8 INPUT 7	PRESET 8	INT	-300.00 to 300.00 %	fl	
562	PRESET 8 SELECT	PRESET 8	ENUM	Same as tag 355	fm	
563	PRESET 8 OUTPUT1	PRESET 8	INT	xxx.xx %	fn	Output
564	PRESET 8 OUTPUT2	PRESET 8	INT	xxx.xx %	fo	Output
565	ENCODER MODE	ENCODER	ENUM	0 : QUADRATURE 1 : CLOCK/DIR 2 : CLOCK	fp	
566	ENCODER LINES	ENCODER	INT	1 to 10000	fq	3
567	ENCODER INVERT	ENCODER	BOOL	FALSE / TRUE	fr	
568	ENCODER SPEED	ENCODER	INT	xxxx.x Hz	fs	Output
569	ENCODER SPEED	ENCODER	INT	xxxxx n/min	ft	Output
570	FLY CATCH ENABLE	FLY CATCHING	BOOL	FALSE / TRUE	fu	
571	FLY START MODE	FLY CATCHING	ENUM	0 : ALWAYS 1 : TRIP OR POWERUP 2 : TRIP	fv	

# Parameter Specification 10-15

Tag	(MMI) Name	Block	Type	Range	ID	Notes
572	FLY SEARCH MODE	FLY CATCHING	ENUM	0 : BIDIRECTIONAL 1 : UNIDIRECTIONAL	fw	
573	FLY SEARCH VOLTS	FLY CATCHING	INT	0.00 to 100.00 %	fx	3
574	FLY SEARCH TIME	FLY CATCHING	INT	0.1 to 60.0 s	fy	3
575	FLY MIN SPEED	FLY CATCHING	INT	5.0 to 480.0 Hz	fz	
576	FLY CATCH ACTIVE	FLY CATCHING	BOOL	FALSE / TRUE	g0	Output
577	INJ FREQUENCY	INJ BRAKING	INT	1.0 to 480.0 Hz	g1	3
578	INJ I-LIM LEVEL	INJ BRAKING	INT	50.00 to 150.00 %	g2	
579	INJ DC PULSE	INJ BRAKING	INT	0.0 to 100.0 s	g3	3
580	INJ FINAL DC	INJ BRAKING	INT	0.0 to 10.0 s	g4	3
581	INJ DC LEVEL	INJ BRAKING	INT	0.00 to 25.00 %	g5	3
582	INJ TIMEOUT	INJ BRAKING	INT	0.0 to 600.0 s	g6	
583	INJ ACTIVE	INJ BRAKING	BOOL	FALSE / TRUE	g7	Output
584	BRAKE ON LOAD	BRAKE CONTROL	INT	0.00 to 150.00 %	g8	
585	BRAKE ON FREQ	BRAKE CONTROL	INT	0.0 to 480.0 Hz	g9	
586	BRAKE OFF FREQ	BRAKE CONTROL	INT	0.0 to 480.0 Hz	ga	
587	BRAKE RELEASE	BRAKE CONTROL	BOOL	FALSE / TRUE	gb	Output
588	BRAKE ON HOLD	BRAKE CONTROL	INT	0.00 to 60.00 s	gc	
589	BRAKE OFF HOLD	BRAKE CONTROL	INT	0.00 to 60.00 s	gd	
590	BRAKE HOLD	BRAKE CONTROL	BOOL	FALSE / TRUE	ge	Output
591	DRIVE FREQUENCY	PATTERN GEN	INT	xxxx.x Hz	gf	Output
592	VOLTS	PATTERN GEN	INT	xxxx.x V	gg	Output
593	BOOST	PATTERN GEN	INT	xxxx.x V	gh	Output
595	VOLTAGE MODE	VOLTAGE CONTROL	ENUM	0 : NONE 1 : FIXED 2 : AUTOMATIC	gj	7
596	SUPPLY VOLTAGE	VECTOR FLUXING	INT	xxxx.x V	gk	Output
598	OUTPUT	MULTIPLEXER	WORD	0000 to FFFF	gm	Output
599	INPUT	DEMULTIPLEXER	WORD	0000 to FFFF	gn	
600	ULC ENABLE	UNDERLAP COMP	BOOL	FALSE / TRUE	go	
603	AUTOTUNE ENABLE	AUTOTUNE	BOOL	FALSE / TRUE	gr	
604	AUTOTUNE ACTIVE	AUTOTUNE	BOOL	FALSE / TRUE	gs	Output
608	AR PENDING	AUTO RESTART	BOOL	FALSE / TRUE	gw	Output
609	AR TRIGGERS 1	AUTO RESTART	WORD	0000 to FFFF	gx	
610	AR INITIAL DLY 1	AUTO RESTART	INT	0.0 to 600.0 s	gy	
611	AR ENABLE	AUTO RESTART	BOOL	FALSE / TRUE	gz	
612	AR ATTEMPTS	AUTO RESTART	INT	1 to 10	h0	
613	AR ATTEMPT DLY 1	AUTO RESTART	INT	0.0 to 600.0 s	h1	
614	AR ATTEMPTS LEFT	AUTO RESTART	INT	xxxxx	h2	Output
615	AR TIME LEFT	AUTO RESTART	INT	xxxx.x s	h3	Output
616	AR RESTARTING	AUTO RESTART	BOOL	FALSE / TRUE	h4	Output
623	REGEN I LIMIT	CURRENT LIMIT	INT	-150.00 to 0.00 %	hb	
626	OP MENU 2	OPERATOR MENU	TAG	0 to 1002	he	
627	OP MENU 3	OPERATOR MENU	TAG	0 to 1002	hf	
628	OP MENU 4	OPERATOR MENU	TAG	0 to 1002	hg	
629	OP MENU 5	OPERATOR MENU	TAG	0 to 1002	hh	
630	OP MENU 6	OPERATOR MENU	TAG	0 to 1002	hi	
631	OP MENU 7	OPERATOR MENU	TAG	0 to 1002	hj	
632	OP MENU 8	OPERATOR MENU	TAG	0 to 1002	hk	

# 10-16 Parameter Specification

Tag	(MMI) Name	Block	Type	Range	ID	Notes
633	OP MENU 9	OPERATOR MENU	TAG	0 to 1002	hl	
634	OP MENU 10	OPERATOR MENU	TAG	0 to 1002	hm	
635	OP MENU 11	OPERATOR MENU	TAG	0 to 1002	hn	
636	OP MENU 12	OPERATOR MENU	TAG	0 to 1002	ho	
637	OP MENU 13	OPERATOR MENU	TAG	0 to 1002	hp	
638	OP MENU 14	OPERATOR MENU	TAG	0 to 1002	hq	
639	OP MENU 15	OPERATOR MENU	TAG	0 to 1002	hr	
641	INPUT 0	MULTIPLEXER	BOOL	FALSE / TRUE	ht	
642	INPUT 1	MULTIPLEXER	BOOL	FALSE / TRUE	hu	
643	INPUT 2	MULTIPLEXER	BOOL	FALSE / TRUE	hv	
644	INPUT 3	MULTIPLEXER	BOOL	FALSE / TRUE	hw	
645	INPUT 4	MULTIPLEXER	BOOL	FALSE / TRUE	hx	
646	INPUT 5	MULTIPLEXER	BOOL	FALSE / TRUE	hy	
647	INPUT 6	MULTIPLEXER	BOOL	FALSE / TRUE	hz	
648	INPUT 7	MULTIPLEXER	BOOL	FALSE / TRUE	i0	
649	INPUT 8	MULTIPLEXER	BOOL	FALSE / TRUE	i1	
650	INPUT 9	MULTIPLEXER	BOOL	FALSE / TRUE	i2	
651	INPUT 10	MULTIPLEXER	BOOL	FALSE / TRUE	i3	
652	INPUT 11	MULTIPLEXER	BOOL	FALSE / TRUE	i4	
653	INPUT 12	MULTIPLEXER	BOOL	FALSE / TRUE	i5	
654	INPUT 13	MULTIPLEXER	BOOL	FALSE / TRUE	i6	
655	INPUT 14	MULTIPLEXER	BOOL	FALSE / TRUE	i7	
656	INPUT 15	MULTIPLEXER	BOOL	FALSE / TRUE	i8	
657	OUTPUT 0	DEMULTIPLEXER	BOOL	FALSE / TRUE	i9	Output
658	OUTPUT 1	DEMULTIPLEXER	BOOL	FALSE / TRUE	ia	Output
659	OUTPUT 2	DEMULTIPLEXER	BOOL	FALSE / TRUE	ib	Output
660	OUTPUT 3	DEMULTIPLEXER	BOOL	FALSE / TRUE	ic	Output
661	OUTPUT 4	DEMULTIPLEXER	BOOL	FALSE / TRUE	id	Output
662	OUTPUT 5	DEMULTIPLEXER	BOOL	FALSE / TRUE	ie	Output
663	OUTPUT 6	DEMULTIPLEXER	BOOL	FALSE / TRUE	if	Output
664	OUTPUT 7	DEMULTIPLEXER	BOOL	FALSE / TRUE	ig	Output
665	OUTPUT 8	DEMULTIPLEXER	BOOL	FALSE / TRUE	ih	Output
666	OUTPUT 9	DEMULTIPLEXER	BOOL	FALSE / TRUE	ii	Output
667	OUTPUT 10	DEMULTIPLEXER	BOOL	FALSE / TRUE	ij	Output
668	OUTPUT 11	DEMULTIPLEXER	BOOL	FALSE / TRUE	ik	Output
669	OUTPUT 12	DEMULTIPLEXER	BOOL	FALSE / TRUE	il	Output
670	OUTPUT 13	DEMULTIPLEXER	BOOL	FALSE / TRUE	im	Output
671	OUTPUT 14	DEMULTIPLEXER	BOOL	FALSE / TRUE	in	Output
672	OUTPUT 15	DEMULTIPLEXER	BOOL	FALSE / TRUE	io	Output
673	COEFFICIENT B	CUSTOM SCREEN 2	INT	1 to 30000	ip	
674	HIGH LIMIT	CUSTOM SCREEN 2	INT	-30000 to 30000	iq	
675	LOW LIMIT	CUSTOM SCREEN 2	INT	-30000 to 30000	ir	
676	FORMULA	CUSTOM SCREEN 2	ENUM	Same as tag 125	is	
677	AR TRIGGERS 2	AUTO RESTART	WORD	0000 to FFFF	it	
678	AR INITIAL DLY 2	AUTO RESTART	INT	0.0 to 600.0 s	iu	
679	AR ATTEMPT DLY 2	AUTO RESTART	INT	0.0 to 600.0 s	iv	
680	SKIP FREQ BAND 2	SKIP FREQUENCIES	INT	0.0 to 480.0 Hz	iw	
681	SKIP FREQ BAND 3	SKIP FREQUENCIES	INT	0.0 to 480.0 Hz	ix	

# Parameter Specification 10-17

Tag	(MMI) Name	Block	Type	Range	ID	Notes
682	SKIP FREQ BAND 4	SKIP FREQUENCIES	INT	0.0 to 480.0 Hz	iy	
686	REGEN LIM ENABLE	CURRENT LIMIT	BOOL	FALSE / TRUE	j2	7
689	AUTOTUNE MODE	AUTOTUNE	ENUM	0 : USER NO LOAD I 1 : CALC NO LOAD I	j5	7
691	SRAMP CONTINUOUS	SYSTEM RAMP	BOOL	FALSE / TRUE	j7	
692	SRAMP ACCEL	SYSTEM RAMP	INT	0.00 to 100.00 %	j8	
693	SRAMP DECEL	SYSTEM RAMP	INT	0.00 to 100.00 %	j9	
694	SRAMP JERK 1	SYSTEM RAMP	INT	0.00 to 100.00 %	ja	
695	SRAMP JERK 2	SYSTEM RAMP	INT	0.00 to 100.00 %	jb	
696	SRAMP JERK 3	SYSTEM RAMP	INT	0.00 to 100.00 %	jc	
697	SRAMP JERK 4	SYSTEM RAMP	INT	0.00 to 100.00 %	jd	
698	RAMPING	SYSTEM RAMP	BOOL	FALSE / TRUE	je	Output
709	FLY REFLUX TIME	FLY CATCHING	INT	0.1 to 20.0 s	jp	
710	INJ DEFLUX TIME	INJ BRAKING	INT	0.1 to 20.0 s	jq	3
711	AIN 3 BREAK ENBL	ANALOG INPUT 3	BOOL	FALSE / TRUE	jr	
712	AIN 3 TYPE	ANALOG INPUT 3	ENUM	Same as tag 13	js	7
713	AIN 3 SCALE	ANALOG INPUT 3	INT	-300.00 to 300.00 %	jt	
714	AIN 3 OFFSET	ANALOG INPUT 3	INT	-300.00 to 300.00 %	ju	
715	AIN 3 VALUE	ANALOG INPUT 3	INT	xxx.xx %	jv	Output
716	AIN 3 BREAK VAL	ANALOG INPUT 3	INT	-300.00 to 300.00 %	jw	
717	AIN 3 BREAK	ANALOG INPUT 3	BOOL	FALSE / TRUE	jx	Output
718	AIN 4 BREAK ENBL	ANALOG INPUT 4	BOOL	FALSE / TRUE	iy	
719	AIN 4 TYPE	ANALOG INPUT 4	ENUM	0 : 0..+10 V 1 : +2..+10 V 2 : 0..+5 V 3 : +1..+5 V	jz	7
720	AIN 4 SCALE	ANALOG INPUT 4	INT	-300.00 to 300.00 %	k0	
721	AIN 4 OFFSET	ANALOG INPUT 4	INT	-300.00 to 300.00 %	k1	
722	AIN 4 VALUE	ANALOG INPUT 4	INT	xxx.xx %	k2	Output
723	AIN 4 BREAK VAL	ANALOG INPUT 4	INT	-300.00 to 300.00 %	k3	
724	AIN 4 BREAK	ANALOG INPUT 4	BOOL	FALSE / TRUE	k4	Output
725	DIN 6 INVERT	DIGITAL INPUT 6	BOOL	FALSE / TRUE	k5	
726	DIN 6 VALUE	DIGITAL INPUT 6	BOOL	FALSE / TRUE	k6	Output
727	DIN 7 INVERT	DIGITAL INPUT 7	BOOL	FALSE / TRUE	k7	
728	DIN 7 VALUE	DIGITAL INPUT 7	BOOL	FALSE / TRUE	k8	Output
729	DIN 8 INVERT	DIGITAL INPUT 8	BOOL	FALSE / TRUE	k9	
730	DIN 8 VALUE	DIGITAL INPUT 8	BOOL	FALSE / TRUE	ka	Output
731	AOUT 2 VALUE	ANALOG OUTPUT 2	INT	-300.00 to 300.00 %	kb	
732	AOUT 2 SCALE	ANALOG OUTPUT 2	INT	-300.00 to 300.00 %	kc	
733	AOUT 2 OFFSET	ANALOG OUTPUT 2	INT	-300.00 to 300.00 %	kd	
734	AOUT 2 ABS	ANALOG OUTPUT 2	BOOL	FALSE / TRUE	ke	
735	AOUT 2 TYPE	ANALOG OUTPUT 2	ENUM	0 : 0..+10 V 1 : -10..+10 V	kf	7
736	DOUT 3 INVERT	DIGITAL OUTPUT 3	BOOL	FALSE / TRUE	kg	
737	DOUT 3 VALUE	DIGITAL OUTPUT 3	BOOL	FALSE / TRUE	kh	
739	INJ BASE VOLTS	INJ BRAKING	INT	0.00 to 115.47 %	kj	3
740	ACTIVE TRIPS+	TRIPS STATUS	WORD	0000 to FFFF	kk	Output
741	TRIP WARNINGS+	TRIPS STATUS	WORD	0000 to FFFF	kl	Output
742	DISABLED TRIPS+	TRIPS STATUS	WORD	0000 to FFFF	km	
744	AR TRIGGERS+ 1	AUTO RESTART	WORD	0000 to FFFF	ko	

# 10-18 Parameter Specification

Tag	(MMI) Name	Block	Type	Range	ID	Notes
745	AR TRIGGERS+ 2	AUTO RESTART	WORD	0000 to FFFF	kp	
747	ENCODER RESET	ENCODER	BOOL	FALSE / TRUE	kr	
748	ENCODER POSITION	ENCODER	INT	xxxxx	ks	Output, 2
749	ENCODER SPEED	ENCODER	INT	xxx.xx%	kt	Output
750	TEC OPTION TYPE	TEC OPTION	ENUM	0 : NONE 1 : RS485 2 : PROFIBUS DP 3 : LINK 4 : DEVICENET 5 : CANOPEN 6 : TYPE 6 7 : TYPE 7	ku	
751	TEC OPTION IN 1	TEC OPTION	INT	-32768 to 32767	kv	
752	TEC OPTION IN 2	TEC OPTION	INT	-32768 to 32767	kw	
753	TEC OPTION IN 3	TEC OPTION	INT	-32768 to 32767	kx	
754	TEC OPTION IN 4	TEC OPTION	INT	-32768 to 32767	ky	
755	TEC OPTION IN 5	TEC OPTION	INT	-32768 to 32767	kz	
756	TEC OPTION FAULT	TEC OPTION	ENUM	0 : NONE 1 : PARAMETER 2 : TYPE MISMATCH 3 : SELF TEST 4 : HARDWARE 5 : MISSING	l0	Output
757	TEC OPTION VER	TEC OPTION	WORD	0000 to FFFF	l1	Output
758	TEC OPTION OUT 1	TEC OPTION	WORD	0000 to FFFF	l2	Output
759	TEC OPTION OUT 2	TEC OPTION	WORD	0000 to FFFF	l3	Output
760	INVERT THERMIST	TRIPS STATUS	BOOL	FALSE / TRUE	l4	
761	ENCODER SUPPLY	ENCODER	INT	10.0 to 20.0V	l5	
762	SLIP ACTIVE	SLIP COMP	BOOL	FALSE / TRUE	l6	Output
763	PID SP NEGATE	PID	BOOL	FALSE / TRUE	l7	
764	PID FEEDBACK	PID	INT	-300.00 to 300.00%	l8	
765	PID FB NEGATE	PID	BOOL	FALSE / TRUE	l9	
766	PID ERROR	PID	INT	xxx.xx%	la	Output

## Product-Related Default Values

All examples given in this book are based on a UK, 400V, 50Hz, 7.5kW Inverter. The parameters shown below have values that can vary with build/configuration.

### Language Dependant Defaults

These parameters (marked with “\*” in function block descriptions and macro diagrams) are set to a value depending on the *Language* portion of the Product Code.

	Tag	English (UK)	German (GR)	French (FR)	Spanish (SP)
LANGUAGE	1	ENGLISH	DEUTSCH	FRANCAIS	ESPANOL
MAX SPEED	57	50.0Hz	50.0Hz	50.0Hz	50.0Hz
BASE FREQUENCY	106	50.0Hz	50.0Hz	50.0Hz	50.0Hz
CONFIGURATION ID	339	AC MOTOR DRIVE	AC MOTOR DRIVE	CONV FREQUENCE	VARIADOR ALTERNA

	Tag	American (US)	P 50Hz (P5)	P 60Hz (P6)
LANGUAGE	1	ENGLISH	{ 0}	{ 0}
MAX SPEED	57	60.0Hz	50.0Hz	60.0Hz
BASE FREQUENCY	106	60.0Hz	50.0Hz	60.0Hz
CONFIGURATION ID	339	AC MOTOR DRIVE	AC MOTOR DRIVE	AC MOTOR DRIVE

# 10-20 Parameter Specification

## AC Supply Voltage and Power Rating Dependant Defaults

These parameters (marked with “\*\*\*” in function block descriptions and macro diagrams) are set to a value depending on the overall “power-build” of the Inverter indicated by the Product Code.

400V Build	AC Supply Voltage and Power Rating Dependant Defaults			
	Tag	5.5kW 400V	7.5kW 400V	11kW 400V
FULL LOAD CALIB	64	11.3	14.6	20.0
NO LOAD CALIB	65	6.8	8.1	10.2
STATOR RES	119	3.07	2.55	2.04
LEAKAGE INDUC	120	32.5	27.1	21.6
MUTUAL INDUC	121	292.7	243.7	194.5
MOTOR VOLTS	122	400.0	400.0	400.0
MOTOR CONNECTION	124	DELTA	DELTA	DELTA
POWER FACTOR	242	0.80	0.83	0.86
NAMEPLATE RPM	83	1445	1450	1460
SLIP MOTOR LIMIT	85	82.5	75.0	60.0
SLIP REGEN LIMIT	86	82.5	75.0	60.0
DEFLUX DELAY	100	2.0	2.0	2.0
DEFLUX TIME	710	0.5	0.5	0.5
FLY SEARCH BOOST	32	40.00	40.00	40.00
FLY SEARCH VOLTS	573	9.00	9.00	9.00
FLY SEARCH TIME	574	10.0	10.0	10.0
INJ FREQUENCY	577	9.0	9.0	9.0
INJ DC PULSE	579	2.0	2.0	2.0
INJ FINAL DC	580	1.0	1.0	1.0
INJ DC LEVEL	581	2.50	2.50	2.50
INJ BASE VOLTS	739	100.00	100.00	100.00
ACCEL RATE	258	10.0	10.0	10.0
DECEL RATE	259	10.0	10.0	10.0
SYMMETRIC RATE	267	10.0	10.0	10.0

500V Build	AC Supply Voltage and Power Rating Dependant Defaults			
	Tag	5.5kW 500V	7.5kW 500V	11kW 500V
FULL LOAD CALIB	64	9.0	11.7	16.0
NO LOAD CALIB	65	5.4	6.5	8.2
STATOR RES	119	3.83	3.19	2.55
LEAKAGE INDUC	120	40.7	33.9	27.0
MUTUAL INDUC	121	365.9	304.7	243.1
MOTOR VOLTS	122	500.0	500.0	500.0
MOTOR CONNECTION	124	DELTA	DELTA	DELTA
POWER FACTOR	242	0.80	0.83	0.86
NAMEPLATE RPM	83	1445	1450	1460
SLIP MOTOR LIMIT	85	82.5	75.0	60.0
SLIP REGEN LIMIT	86	82.5	75.0	60.0
DEFLUX DELAY	100	2.0	2.0	2.0
DEFLUX TIME	710	0.5	0.5	0.5
FLY SEARCH BOOST	32	40.00	40.00	40.00
FLY SEARCH VOLTS	573	9.00	9.00	9.00
FLY SEARCH TIME	574	10.0	10.0	10.0
INJ FREQUENCY	577	9.0	9.0	9.0
INJ DC PULSE	579	2.0	2.0	2.0
INJ FINAL DC	580	1.0	1.0	1.0
INJ DC LEVEL	581	4.00	4.00	4.00
INJ BASE VOLTS	739	100.00	100.00	100.00
ACCEL RATE	258	10.00	10.0	10.0
DECEL RATE	259	10.00	10.0	10.0
SYMMETRIC RATE	267	10.00	10.0	10.0

# 10-22 Parameter Specification

# TECHNICAL SPECIFICATIONS

## 605C Model Recognition

The 605C Inverter is produced in three power ratings, identified by the Product Code. Each power rating is also available as a 400V or 500V build variant.

### 400V Build Variant: 380-460V Supply



Model Recognition	CONSTANT TORQUE	QUADRATIC TORQUE
Product Code <i>Refer to Chapter 2 for details</i>	Motor Power (kW/hp)	Motor Power (kW/hp)
605C/0055/400/..	5.5/7.5	7.5/10
605C/0075/400/..	7.5/10	11/15
605C/0110/400/..	11/15	15/20
500V Build Variant: 380-500V Supply		
Model Recognition	CONSTANT TORQUE	QUADRATIC TORQUE
Product Code <i>Refer to Chapter 2 for details</i>	Motor Power (kW/hp)	Motor Power (kW/hp)
605C/0055/500/..	5.5/7.5	7.5/10
605C/0075/500/..	7.5/10	11/15
605C/0110/500/..	11/15	15/20

## Environmental Details

<b>Operating Temperature</b>	Operating temperature is defined as the ambient temperature to the immediate surround of the Inverter, when the Inverter and other equipment adjacent to it is operating at worst case conditions.	
	Constant Torque	0°C to 45°C (0°C to 40°C with top cover fitted), derate up to a maximum of 50°C
Quadratic Torque	0°C to 40°C (0°C to 40°C with top cover fitted), derate up to a maximum of 50°C	
<b>Storage Temperature</b>	-25°C to +55°C	
<b>Shipping Temperature</b>	-25°C to +70 °C	
<b>Product Enclosure Rating</b>	Cubicle Mounted (with top cover fitted)	IP40 - top cover surface (Europe) IP20 - remainder of surfaces (Europe)
	Cubicle Mounted (without top cover fitted)	IP20 UL (c-UL) Open Type (North America/Canada)
	Wall Mounted	UL (c-UL) Type 1 (North America/Canada)
<b>Altitude</b>	If > 1000 metres above sea level, derate Motor Power rating by 1% per 100 metres	
<b>Humidity</b>	Maximum 85% relative humidity at 40°C non-condensing	
<b>Atmosphere</b>	Non flammable, non corrosive and dust free	
<b>Climatic Conditions</b>	Class 3k3, as defined by EN50178 (1997)	
<b>Vibration</b>	Test Fc of EN60068-2-6 19Hz <= f <= 57Hz sinusoidal 0.075mm amplitude 57Hz <= f <= 150Hz sinusoidal 1g 10 sweep cycles per axis on each of three mutually perpendicular axis	
<b>Safety</b>	Overvoltage Category	Overvoltage Category III
	Pollution Degree	Pollution Degree 2
	Europe	When fitted inside a cubicle, or when wall-mounted and the top cover is firmly screwed in position, this product conforms with the Low Voltage Directive 73/23/EEC with amendment 93/68/EEC, Article 13 and Annex III using EN50178 (1997) to show compliance.
North America/Canada	Without the top cover fitted, complies with the requirements of UL508C as an open-type drive. When the top cover is fitted, complies with the requirements of UL508C as Type 1 Enclosed (for direct wall mounting applications) when specified with Product Code Block 4 designation xx2x only.	

# 11-2 Technical Specifications

## Earthing/Safety Details

<b>Earthing</b>	<p>Permanent earthing is mandatory on all units.</p> <p>Use a copper protective earth conductor 10mm<sup>2</sup> minimum cross-section, or install a second conductor in parallel with the protective conductor to a separate protective earth terminal</p> <p>The conductor itself must meet local requirements for a protective earth conductor</p>
<b>Input Supply Details (TN) and (IT)</b>	<p>Units with single phase or 3 phase external filters are only suitable for use on earth referenced supplies (TN).</p> <p>Units without filters are suitable for earth (TN) or non-earth referenced (IT) supplies.</p>
<b>Prospective Short Circuit Current (PSCC)</b>	10kA maximum

## Terminal Block Wire Sizes

Wire sizes should be chosen with respect to the operating conditions and your local National Electrical Safety Installation Requirements.

Model Recognition Product Code	Constant/Quadratic	Power Terminals (maximum wire size)	Control Terminals , including Thermistor block on Power Board (maximum acceptance for aperture)
605C/0055/400/..	5.5kW/7.5kW	4mm <sup>2</sup> (12 AWG)	2.5mm <sup>2</sup> (14 AWG)
605C/0075/400/..	7.5kW/11kW	10mm <sup>2</sup> (8 AWG)	2.5mm <sup>2</sup> (14 AWG)
605C/0110/400/..	11kW/15kW	10mm <sup>2</sup> (8 AWG)	2.5mm <sup>2</sup> (14 AWG)
<b>Earth Leakage Current</b>	> 10mA (all models)		

## Electrical Ratings

Motor power, output current and input current must not be exceeded under steady state operating conditions. Also see 605C Model Recognition, page 11-1.

Local wiring regulations always take precedence.

\* European wire sizes (mm<sup>2</sup>) are based on EN60204-1 (1993) for PVC single-core cable bunched or in trunking given a 70°C maximum conductor temperature under normal conditions in a 45°C ambient for Constant Torque and a 40°C ambient for Quadratic Torque.

✦ North American wire sizes (AWG) are based on NEC/NFPA-70 for ampacities of thermoplastic-insulated (75°C) copper conductors assuming not more than three current-carrying conductors in raceway or cable, based on ambient temperature of 30°C. The wire sizes allow for an ampacity of 125% of the rated input and output amperes for motor branch-circuit conductors as specified in NEC/NFPA-70.

### 400V Build Variant: 380-460V ±10%, 45-65Hz

For UL Listed products rated at 20Hp a supply voltage of 460V is required  
 ◆=Higher current ratings applicable to non UL applications



#### CONSTANT TORQUE (Output Overload Motoring 150% for 60s)

Model Recognition Product Code	Motor Power (kW/hp)	Output Current (A)	Wire Size ✦✦ AWG (mm <sup>2</sup> )	Input Current (A)	Wire Size ✦✦ AWG (mm <sup>2</sup> )	Input Fuse Rating (A)	Maximum Power Loss (W)	Maximum Switching Frequency (kHz)
605C/0055/400/..	5.5/7.5	12	14 (1.5)	15	12 (2.5)	20	220	6
605C/0075/400/..	7.5/10	16	12 (2.5)	22	10 (4)	32	260	6
605C/0110/400/..	11/15	23	10 (6)	28	8 (6)	32	330	6

#### QUADRATIC TORQUE (Output Overload Motoring 110% for 10s)

Model Recognition Product Code	Motor Power (kW/hp)	Output Current (A)	Wire Size ✦✦ AWG (mm <sup>2</sup> )	Input Current (A)	Wire Size ✦✦ AWG (mm <sup>2</sup> )	Input Fuse Rating (A)	Maximum Power Loss (W)	Maximum Switching Frequency (kHz)
605C/0055/400/..	7.5/10	16	12 (2.5)	20	10 (4)	32	270	3
605C/0075/400/..	11/15	23	10 (4)	28	8 (6)	32	350	3
605C/0110/400/..	15/20	27 (◆31)	8 (6)	32 (◆35)	8 (10)	40	450	3

### 500V Build Variant: 500V ±10%, 45-65Hz

500V unit full ratings are only available at 500V.  
 The unit can be operated at between 380-500V with reduced power output below 500V

#### CONSTANT TORQUE (Output Overload Motoring 150% for 60s)

Model Recognition Product Code	Motor Power (kW/hp)	Output Current (A)	Wire Size (mm <sup>2</sup> )	Input Current (A)	Wire Size (mm <sup>2</sup> )	Input Fuse Rating (A)	Maximum Power Loss (W)	Maximum Switching Frequency (kHz)
605C/0055/500/..	5.5/7.5	10	1.5	14	2.5	20	220	6
605C/0075/500/..	7.5/10	12.5	2.5	22	4	32	260	6
605C/0110/500/..	11/15	18	4	26	6	32	330	6

#### QUADRATIC TORQUE (Output Overload Motoring 110% for 10s)

Model Recognition Product Code	Motor Power (kW/hp)	Output Current (A)	Wire Size (mm <sup>2</sup> )	Input Current (A)	Wire Size (mm <sup>2</sup> )	Input Fuse Rating (A)	Maximum Power Loss (W)	Maximum Switching Frequency (kHz)
605C/0055/500/..	7.5/10	12.5	1.5	20	4	32	270	3
605C/0075/500/..	11/15	18	2.5	26	6	32	350	3
605C/0110/500/..	15/20	24	4	32	10	40	450	3

# 11-4 Technical Specifications

## Cabling Requirements for EMC Compliance

	Power Supply Cable	Motor Cable	External AC Supply EMC Filter to Inverter Cable	Brake Resistor Cable	Signal/Control Cable
Cable Type (for EMC Compliance)	Unscreened	Screened/armoured	Screened/armoured	Screened/armoured	Screened
Segregation	From all other wiring (clean)	From all other wiring (noisy)			From all other wiring (sensitive)
Length Limitations With External AC Supply EMC Filter	Unlimited	Refer to "External AC Supply (RFI) Filters" table	0.3 metres	25 metres	25 metres
Screen to Earth Connection		Both ends	Both ends	Both ends	Inverter end only
Output Choke		300 metres maximum			

## EMC Compliance

All models	European Community Directive 89/336/EEC
All models	EN50082-1 (1992) and prEN50082-2 (1992) for immunity
If fitted external filters	EN50081-2 (1994) for Radiated Emissions when wall-mounted EN50081-1 (1994) for Radiated Emissions when cubicle-mounted EN50081-2 (1994) for Conducted Emissions all models

## External AC Supply (RFI) Filters

External AC Supply EMC Filter Part No.	Input Supply Details suitable for earth referenced supplies only (TN)	Motor Power Constant Torque (kW/hp)	Motor Power Quadratic Torque (kW/hp)
CO465188U020	380-500V $\pm 10\%$ , 50-60Hz $\pm 5\%$	upto 5.5/7.5	upto 7.5/10
CO465188U036	380-500V $\pm 10\%$ , 50-60Hz $\pm 5\%$	7.5-11/10-15	11-15/15-20

External AC Supply EMC Filter Part No.	Watt Loss at Full Load Current (W)	Switching Frequency (kHz)	Maximum Motor Cable Length (metres)	Gland Box Kit (optional)
CO465188U020	11	3 quadratic 3 & 6 constant	50	BA465189U020
CO465188U036	16	3 quadratic 3 & 6 constant	50	BA465189U036

<b>Internal Dynamic Brake Switch</b>						
Model Recognition Product Code	Motor Power (kW/hp)	Brake Switch Peak Current (A)	Peak Brake Dissipation (kW/hp)	Brake Switch Continuous Current (A)	Continuous Brake Dissipation (kW/hp)	Minimum Brake Resistor Value ( $\Omega$ )
		20s maximum, 30% duty				
<b>400V Build Variant: 380-460V <math>\pm</math>10%, 45-65Hz</b> DC link brake voltage: 750V						
605C/0055/400/..	5.5/7.5	7.5	5.5/7.5	2.3	1.7/2.3	100
605C/0075/400/..	7.5/10	15	11/15	4.5	3.4/4.5	50
605C/0110/400/..	11/15	15	11/15	4.5	3.4/4.5	50
<b>500V Build Variant: 500V <math>\pm</math>10%, 45-65Hz</b> DC link brake voltage: 815V						
605C/0055/400/..	5.5/7.5	7.5	6.1/8.2	2.25	1.8/2.5	100
605C/0075/400/..	7.5/10	15	12.2/16.3	4.5	3.7/4.9	50
605C/0110/400/..	11/15	15	12.2/16.3	4.5	3.7/4.9	50

# 11-6 Technical Specifications

<b>Control Terminals</b>				
Terminal No.	Block No.	Name	Range	Description
<b>TB1 : ANALOG I/O TERMINAL BLOCK</b>				
This is a 10-way connector carrying all customer analog I/O.				
1	TB1-1	AIN1 (SPEED)	0-10V, $\pm 10V$ , 0-20mA, 4-20mA	Configurable analog input Default function = Speed Setpoint
2	TB1-2	AIN2 (TRIM)	0-10V, $\pm 10V$ , 0-20mA, 4-20mA	Configurable analog input Default function = Speed Trim
3	TB1-3	AIN3	0-20mA, 4-20mA	Configurable analog input
4	TB1-4	0V		0V reference for analog i/o
5	TB1-5	AIN4	0-10V	Configurable analog input
6	TB1-6	AOUT1 (RAMP)	0-10V, 0-20mA, 4-20mA	Configurable analog output Default function = Ramp Output
7	TB1-7	AOUT2	$\pm 10V$	Configurable analog output Default function = Ramp Output
8	TB1-8	+10V REF	10V	10V reference for analog i/o Load 5mA maximum
9	TB1-9	0V	0V	0V reference for digital i/o
10	TB1-10	-10V REF	-10V	-10V reference for analog i/o Load 5mA maximum
<b>TB3 : DIGITAL INPUT TERMINAL BLOCK</b>				
This is a 10-way connector carrying all digital inputs.				
11	TB3-1	+24VC		Customer +24V (max load 150mA)
12	TB3-2	0V		All inputs below 24V=high , 0V=low
13	TB3-3	DIN1 (RUN)	0-24V	Configurable digital input Default function = RUN 0V = Stop, 24V = Run
14	TB3-4	DIN2 (TRIP RESET)	0-24V	Default function = Trip Reset
15	TB3-5	DIN3 (DIR)	0-24V	Configurable digital input Default function = DIRECTION 24V = Reverse, 0V = Forward
16	TB3-6	DIN4 (EXT TRIP)	0-24V	Configurable digital input Default function = EXTERNAL TRIP (active low) 24V = No Trip, 0V = Trip
17	TB3-7	DIN 5 (JOG)	0-24V	Configurable digital input Default function = JOG 24V = Jog, 0V = Stop
18	TB3-8	DIN6	0-24V	Default function: NON-USER DEFINED
19	TB3-9	DIN7	0-24V	Default function: NON-USER DEFINED
20	TB3-10	DIN8	0-24V	Default function: NON-USER DEFINED
<b>TB4 : RELAY OUTPUT TERMINAL BLOCK</b>				
These relay outputs are volt-free, normally-open contacts rated to 250V, 3A with resistive load. Connection is by a 6-way spring clamp connector.				
21	TB4	DOUT1_A	normally-open relay contacts	Default Function DOUT1 closed = Healthy
22		DOUT1_B		
23	TB4	DOUT2_A	normally-open relay contacts	Default Function DOUT2 closed = Running
24		DOUT2_B		
25	TB4	DOUT3_A	normally-open relay contacts	Default Function NON-USER DEFINED
26		DOUT3_B		

<b>Analog Inputs/Outputs</b>		
	<b>Inputs</b>	<b>Output</b>
<b>Range</b>	0-10V, $\pm 10V$ , 0-20mA or 4-20mA set by I/O configuration switch. Refer to Chapter 6: "Programming Your Application" - ANALOG INPUT for switch setting details.	0-10V, 0-20mA or 4-20mA set by I/O configuration switch. Refer to Chapter 6: "Programming Your Application" - ANALOG OUTPUT for switch setting details.
<b>Impedance</b>	Voltage range = $94k\Omega$ Current range = $220\Omega$	Voltage range = $100\Omega$ Current range = $100\Omega$
<b>Resolution</b>	10 bits (1 in 1024)	8 bits (1 in 256)
<b>Sample Rate</b>	20ms	

<b>Digital Inputs</b>			
<b>Range</b>	-30V dc minimum	24V dc nominal	+30V dc maximum
<b>Threshold</b>	6V dc minimum	12V dc typical	18V dc maximum
<b>Input Impedance</b>	47k $\Omega$		
<b>Sample Rate</b>	20ms		

<b>Digital Outputs</b>	
These are volt-free relay contacts.	
<b>Maximum Voltage</b>	230V ac
<b>Maximum Current</b>	3A resistive load

# 11-8 Technical Specifications

## Supply Harmonic Analysis

Assumptions: 10000A short circuit supply capability, equivalent to 73μH supply impedance

$$THD(V) \times 100 = \frac{\sqrt{\sum_{h=2}^{h=40} Q_{h^2}}}{Q_{1n}} \%$$

where  $Q_{1n}$  is the rated rms value of the fundamental voltage of the supply transformer.

The results conform to stage 1, stage 2 and stage 3 of the Engineering Recommendation G.5/3 September 1976, Classification 'C': Limits for Harmonics in the UK Electricity Industry.

Drive Type	605C			
Motor Power (kW)	5.5	7.5	11	15
Fundamental Voltage (V)	415	415	415	415
Typical Motor Efficiency %	88	89	91	92
Harmonic No.	RMS Current (A)			
1	10.29	11.95	17.20	22.73
5	8.65	10.06	14.05	18.37
7	7.14	8.39	11.37	14.67
11	3.90	4.66	5.59	6.89
13	2.54	2.98	3.20	3.80
17	0.65	0.88	0.94	1.31
19	0.53	0.71	1.03	1.41
23	0.54	0.70	0.78	0.92
25	0.44	0.54	0.51	0.61
29	0.23	0.32	0.43	0.55
31	0.22	0.31	0.43	0.50
35	0.20	0.28	0.29	0.30
37	0.16	0.22	0.23	0.29
Total RMS Current (A)	15.9	18.64	25.83	33.72
THD (V) %	0.87	1.16	1.51	1.84

# CERTIFICATION FOR THE INVERTER

## Requirements for EMC Compliance

All Variable Speed Drives (VSDs) potentially produce electrical emissions which are radiated into the environment and conducted back into the ac supply. VSDs are inherently immune to any additional external electrical noise. The following information is provided to maximise the Electro Magnetic Compatibility (EMC) of VSDs and systems in their intended operating environment, by minimising their emissions and maximising their immunity.

### Minimising Radiated Emissions

EN55011/EN55022 radiated emission measurements are made between 30MHz and 1GHz in the far field at a distance of 10 to 30 metres. Limits lower than 30MHz or in close proximity are not specified. Emissions from individual components tend to be additive.

- Use a screened/armoured cable between VSD/cubicle and motor containing the motor protective earth (PE) connection. It should have a 360° screen termination. Earth screen at both ends connecting to the motor frame and cubicle (or gland box if wall mounted). Maintain the screen integrity using 360° terminations.

**Note:** Some hazardous area installations may preclude direct earthing at both ends of the screen, in this case earth one end via a 1 $\mu$ F 50Vac capacitor, and the other as normal.

- Keep unshielded cable as short as possible inside the cubicle.
- Always maintain the integrity of the shield.
- If the cable is interrupted to insert contactors etc., re-connect the screen using the shortest possible route.
- Keep the length of screen stripped-back as short as possible when making screen connections.
- Ideally use 360° screen terminations using cable glands or 'U' clips on power screen rails.

If a shielded cable is not available, lay unshielded motor cables in a metal conduit which will act as a shield. The conduit must be continuous with a direct electrical contact to the VSD and motor housing. If links are necessary, use braid with a minimum cross sectional area of 10mm<sup>2</sup>.

**Note:** Some motor gland boxes and conduit glands are made of plastic, if this is the case, then braid must be connected between the screen and the chassis. In addition at the motor end, ensure that the screen is electrically connected to the motor frame since some terminal boxes are insulated from the frame by gasket/paint.

### Earthing Requirements

**IMPORTANT:** Protective earthing always takes precedence over EMC earthing.

#### Protective Earth (PE) Connections

**Note:** In accordance with installations to EN60204, only one protective earth conductor is permitted at each protective earth terminal contacting point.

Local wiring regulations may require the protective earth connection of the motor to be connected locally, i.e. not as specified in these instructions. This will not cause shielding problems because of the relatively high RF impedance of the local earth connection.

#### EMC Earth Connections

For compliance with EMC requirements, we recommend that the "0V/signal ground" is separately earthed. When a number of units are used in a system, these terminals should be connected together at a single, local earthing point.

## 12-2 Certification for the Inverter

Control and signal cables for the encoder, all analog inputs, and communications require screening with the screen connected only at the VSD end. However, if high frequency noise is still a problem, earth screen at the non VSD end via a 0.1µF capacitor.

**Note:** Connect the screen (at the VSD end) to the VSD protective earth point, and not to the control board terminals.

### Cabling Requirements

**Note:** Refer to Chapter 11: "Technical Specifications" for additional Cabling Requirements.

#### Planning Cable Runs

- Use the shortest possible motor cable lengths.
- Use a single length of cable to a star junction point to feed multiple motors.
- Keep electrically noisy and sensitive cables apart.
- Keep electrically noisy and sensitive parallel cable runs to a minimum. Separate parallel cable runs by at least 0.25 metres. For runs longer than 10 metres, separation should be increased proportionally. For example if the parallel runs were 50m, then the separation would be  $(50/10) \times 0.25\text{m} = 1.25\text{m}$ .
- Sensitive cables should cross noisy cables at 90°.
- Never run sensitive cables close or parallel to the motor, dc link and braking chopper circuit for any distance.
- Never run supply, dc link or motor cables in the same bundle as the signal/control and feedback cables, even if they are screened.
- Ensure EMC filter input and output cables are separately routed and do not couple across the filter.

#### Increasing Motor Cable Length

Because cable capacitance and hence conducted emissions increase with motor cable length, conformance to EMC limits is only guaranteed with the specified ac supply filter option using a maximum cable length as specified in Chapter 11: "Technical Specifications".

This maximum cable length can be improved using the specified external input or output filters. Refer to Chapter 11: "Technical Specifications" - External Filters.

Screened/armoured cable has significant capacitance between the conductors and screen which increases linearly with cable length (typically 200pF/m but varies with cable type and current rating).

Long cable lengths may have the following undesirable effects:

- Tripping on 'overcurrent' as the cable capacitance is charged and discharged at the switching frequency.
- Producing increased conducted emissions which degrade the performance of the EMC filter due to saturation.
- Causing RCDs (Residual Current Devices) to trip due to increased high frequency earth current.
- Producing increased heating inside the EMC ac supply filter from the increased conducted emissions.

These effects can be overcome by adding chokes or output filters at the output of the VSD.

## EMC Installation Options

The unit, when installed for Class A or Class B operation, will be compliant with EN55011 (1991)/ EN55022 (1994) for radiated emissions, as described below.

### Screening & Earthing (wall mounted, Class A)

**IMPORTANT:** This unit must be fitted with the optional top cover and gland box.

The unit is installed for Class A operation when wall mounted using the recommended ac supply filter and having complied with all cabling requirements.

**Note:** *The installation requirements of local safety standards must be achieved regarding the safety of electrical equipment for machines.*

- A single-star point earthing policy as shown in Figure 12-2 is required.
- The protective earth connection (PE) to the motor must be run inside the screened cable between the motor and VSD and be connected to the protective earth terminal in the gland box, or on the VSD.
- The ac supply filter must be permanently earthed. Refer to Chapter 11: “Technical Specifications” - Earthing/Safety Details.
- The signal/control cables should be screened.

**Note:** *Refer to Chapter 11: “Technical Specifications” for details on Cabling Requirements.*

### Screening & Earthing (cubicle mounted, Class B)

**Note:** *The installation requirements of local safety standards must be achieved regarding the safety of electrical equipment for machines.. Refer to Chapter 3: “Installing the Inverter” - Protective Earth (PE) Connections .*

The unit is installed for Class B operation when mounted inside a cubicle having 10dB attenuation between 30 and 100MHz (typically the attenuation provided by a metal cabinet with no aperture of dimension greater than 0.15m), using the recommended ac supply filter and having met all cabling requirements.

**Note:** *Radiated magnetic and electric fields inside the cubicle will be high and any components fitted inside must be sufficiently immune.*

The VSD, external filter and associated equipment are mounted onto a conducting, metal mounting panel. Do not use cubicle constructions that use insulating mounting panels or undefined mounting structures. Cables between the VSD and motor must be screened or armoured and terminated at the VSD or locally on the back panel.

## 12-4 Certification for the Inverter

### Single VSD - Single Motor

Apply a single point series earthing strategy for a single VSD mounted in a cubicle as shown.

The protective earth connection (PE) to the motor must be run inside the screened cable between the motor and VSD and be connected to the motor protective earth terminal on the VSD.

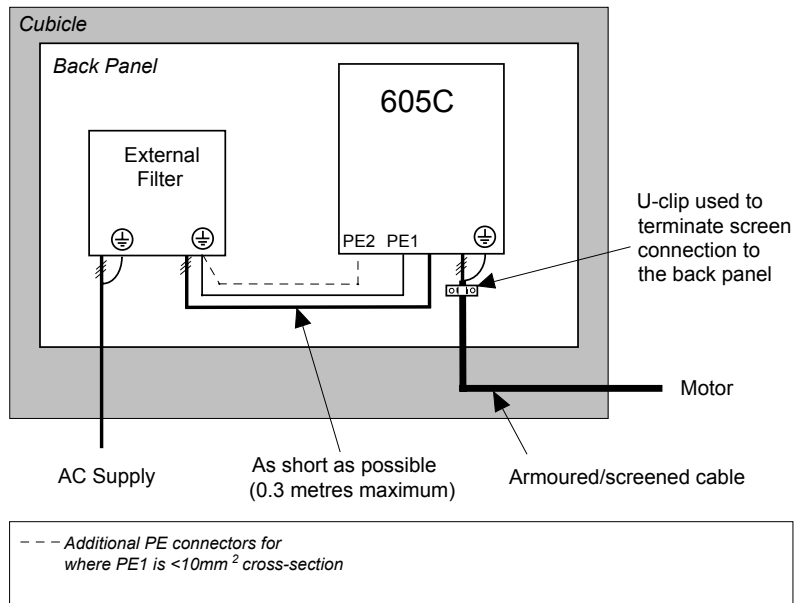

Figure 12-1 EMC and Safety Earthing Cabling

### Single VSD - Multiple Motors

**Note:** Refer to Chapter 13: "Application Notes" - Using Multiple Motors on a Single Drive.

If connecting multiple motors to a single VSD, use a star junction point for motor cable connections. Use a metal box with entry and exit cable glands to maintain shield integrity. Refer to Chapter 13: "Using Multiple Motors on a Single Inverter".

## Star Point Earthing

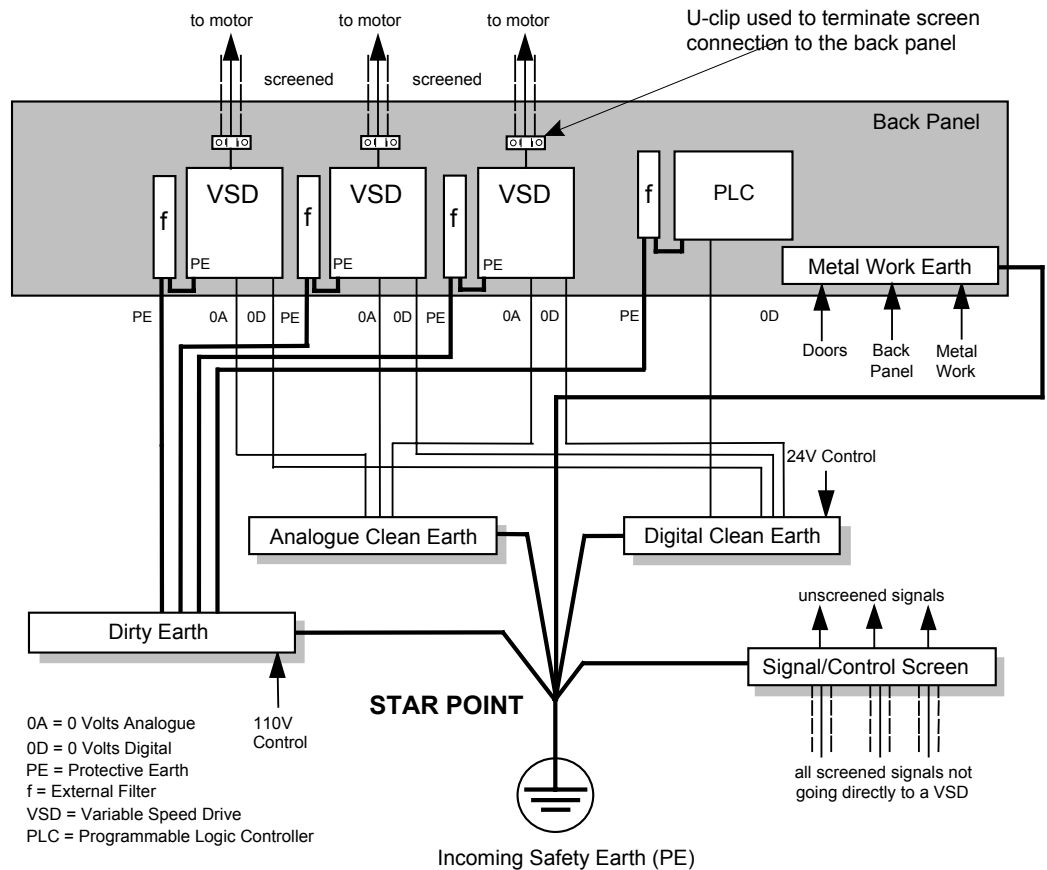

Figure 12-2 Star Point Earthing

A star-point earthing policy separates 'noisy' and 'clean' earths. Four separate earth busbars (three are insulated from the mounting panel) connect to a single earth point (star point) near the incoming safety earth from the main supply. Flexible, large cross-section cable is used to ensure a low HF impedance. Busbars are arranged so that connection to the single earth point is as short as possible.

### 1 Clean Earth Busbar (insulated from the mounting panel)

Used as a reference point for all signal and control cabling. This may be further subdivided into an analog and a digital reference busbar, each separately connected to the star earthing point. The digital reference is also used for any 24V control.

**Note:** The 605C uses a single clean earth busbar for analog and digital.

### 2 Dirty Earth Busbar (insulated from the mounting panel)

Used for all power earths, i.e. protective earth connection. It is also used as a reference for any 110 or 220V control used, and for the control transformer screen.

## 12-6 Certification for the Inverter

### **3 Metal Work Earth Busbar**

The back panel is used as this earth busbar, and should provide earthing points for all parts of the cubicle including panels and doors. This busbar is also used for power screened cables which terminate near to (10cm) or directly into a VSD - such as motor cables, braking choppers and their resistors, or between VSDs - refer to the appropriate product manual to identify these. Use U-clips to clamp the screened cables to the back panel to ensure optimum HF connection.

### **4 Signal/Control Screen Earth Busbar (insulated from the mounting panel)**

Used for signal/control screened cables which **do not** go directly to the VSD. Place this busbar as close as possible to the point of cable entry. 'U' clamp the screened cables to the busbars to ensure an optimum HF connection.

## **Sensitive Equipment**

The proximity of the source and victim circuit has a large effect on radiated coupling. The electromagnetic fields produced by VSDs falls off rapidly with distance from the cabling/cubicle. Remember that the radiated fields from EMC compliant drive systems are measured at least 10m from the equipment, over the band 30-1000MHz. Any equipment placed closer than this will see larger magnitude fields, especially when very close to the Inverter.

Do not place magnetic/electric field sensitive equipment within 0.25 metres of the following parts of the VSD system:

- Variable Speed Drive (VSD)
- EMC output filters
- Input or output chokes/transformers
- The cable between VSD and motor (even when screened/armoured)
- Connections to external braking chopper and resistor (even when screened/armoured)
- AC/DC brushed motors (due to commutation)
- DC link connections (even when screened/armoured)
- Relays and contactors (even when suppressed)

From experience, the following equipment is particularly sensitive and requires careful installation.

- Any transducers which produce low level analog outputs (<1V) , e.g. load cells, strain gauges, thermocouples, piezoelectric transducers, anemometers, LVDTs
- Wide band width control inputs (>100Hz)
- AM radios (long and medium wave only)
- Video cameras and closed circuit TV
- Office personal computers
- Capacitive devices such as proximity sensors and level transducers
- Mains borne communication systems
- Equipment not suitable for operation in the intended EMC environment, i.e. with insufficient immunity to new EMC standards

## Requirements for UL Compliance

### Solid-State Motor Overload Protection

These devices provide Class 10 motor overload protection. The maximum internal overload protection level (current limit) is 150% for 60 seconds, and for quadratic torque 110% for 10 seconds. Refer to Chapter 6: Programming Your Application - I\*t TRIP for user current limit adjustment information.

An external motor overload protective device must be provided by the installer where the motor has a full-load ampere rating of less than 50% of the Inverter output rating.

### Short Circuit Rating

All models of this Inverter are suitable for use on a circuit capable of delivering not more than 10,000 RMS Symmetrical Amperes, 460V maximum.

### Solid-State Short-Circuit Protection

These devices are provided with Solid-State Short-Circuit (output) Protection. Branch circuit protection requirements must be in accordance with the latest edition of the National Electrical Code NEC/NFPA-70.

### Recommended Branch Circuit Protection

It is recommended that UL Listed (JDDZ) non-renewable cartridge fuses, Class K5 or H; or UL Listed (JDRX) renewable cartridge fuses, Class H, are installed upstream of the Inverter. Refer to Chapter 11: “Technical Specifications” - Power Details for recommended fuse ratings.

### Motor Base Frequency

The motor base frequency rating is 480Hz maximum.

### Field Wiring Temperature Rating

Use 75°C Copper conductors only.

### Field Wiring Terminal Markings

For correct field wiring connections that are to be made to each terminal refer to Chapter 3: “Installing the Inverter” - Power Wiring Connections, and Control Wiring Connections.

### Power Wiring Terminals

Model Recognition Product Code (Block 2 & 3)	Power Terminals (maximum wire size)	Brake Terminals (maximum wire size)	Thermistor Terminals (maximum wire size)
0055/400	12 AWG (3.3mm <sup>2</sup> )	12 AWG (3.3mm <sup>2</sup> )	12 AWG (3.3mm <sup>2</sup> )
0075/400	8 AWG (8.4mm <sup>2</sup> )	12 AWG (3.3mm <sup>2</sup> )	12 AWG (3.3mm <sup>2</sup> )
0110/400	8 AWG (8.4mm <sup>2</sup> )	12 AWG (3.3mm <sup>2</sup> )	12 AWG (3.3mm <sup>2</sup> )

### Terminal Tightening Torque

Model Recognition Product Code (Block 2 & 3)	Power Terminals (lb-in)	Brake Terminals (lb-in)
0055/400	12	12
0075/400	16	12
0110/400	16	12

## 12-8 Certification for the Inverter

### **Field Grounding Terminals**

The field grounding terminals are identified with the International Grounding Symbol (IEC Publication 417, Symbol 5019).



### **Operating Ambient Temperature**

Heavy duty devices are considered acceptable for use in a maximum ambient temperature of 45°C (40°C for models with a Type 1 Enclosure). Normal duty devices are considered suitable for use in a maximum ambient temperature of 40°C for both 'open type' and Type 1 Enclosed models.

### **Direct Wall-Mountable Models**

All model of this Inverter with a Product Code Block 4 designation xx2x are suitable for direct wall mounting applications as they have a "Type 1 Enclosure" rating.

In order to preserve this enclosure rating, it is important to maintain the environmental integrity of the enclosure. Therefore, the installer must provide correct Type 1 closures for all unused clearance holes provided within the Inverter's glandplate.

Type 1 Enclosed models are suitable for use in no worse than a Pollution Degree 2 environment.

## European Directives and the CE Mark

The following information is supplied to provide a basic understanding of the EMC and low voltage directives CE marking requirements. The following literature is recommended for further information:

- *Recommendations for Application of Power Drive Systems (PDS), European Council Directives - CE Marking and Technical Standardisation - (CEMEP)*

Available from your local trade association or SSD Drives office

- *EMC Installation Guidelines for Modules and Systems - (SSD Drives)*

Available from your local SSD Drives office, part number HA388879

The European machines and drives manufacturers via their national trade associations have formed the European Committee of Manufacturers of Electrical Machines and Power Electronics (CEMEP). SSD Drives and other major European drives manufacturers are working to the CEMEP recommendations on CE marking. The CE mark shows that a product complies with the relevant EU directives, in our case the Low Voltage Directive and, in some instances, the EMC Directive.

### CE Marking for Low Voltage Directive

When installed in accordance with this manual, the 605C Inverter is CE marked by SSD Drives Ltd in accordance with the low voltage directive (S.I. No. 3260 implements this LVD directive into UK law). An EC Declaration of Conformity (low voltage directive) is included at the end of this chapter.

### CE Marking for EMC - Who is Responsible?

**Note:** *The specified EMC emission and immunity performance of this unit can only be achieved when the unit is installed to the EMC Installation Instructions given in this manual.*

According to S.I. No. 2373 which implements the EMC directive into UK law, the requirement for CE marking this unit falls into two categories:

1. Where the supplied unit has an intrinsic/direct function to the end user, then the unit is classed as **relevant apparatus**.
2. Where the supplied unit is incorporated into a higher system/apparatus or machine which includes (at least) the motor, cable and a driven load but is unable to function without this unit, then the unit is classed as a **component**.

#### ■ Relevant Apparatus - SSD Drives Responsibility

Occasionally, say in a case where an existing fixed speed motor - such as a fan or pump - is converted to variable speed with an add-on drive module (*relevant apparatus*), it becomes the responsibility of SSD Drives to apply the CE mark and issue an EC Declaration of Conformity for the EMC Directive. This declaration and the CE mark is included at the end of this chapter.

#### ■ Component - Customer Responsibility

The majority of SSD Drives' products are classed as *components* and therefore we cannot apply the CE mark or produce an EC Declaration of Conformity in respect of EMC. It is therefore the manufacturer/supplier/installer of the higher system/apparatus or machine who must conform to the EMC directive and CE mark.

## Legal Requirements for CE Marking

**IMPORTANT:** Before installation, clearly understand who is responsible for conformance with the EMC directive. Misappropriation of the CE mark is a criminal offence.

It is important that you have now defined who is responsible for conforming to the EMC directive, either:

### ■ SSD Drives Responsibility

You intend to use the unit as *relevant apparatus*.

When the specified EMC filter is correctly fitted to the unit following EMC installation instructions, it complies with the relevant standards indicated in the following tables. The fitting of the filter is mandatory for the CE marking of this unit to apply.

The relevant declarations are to be found at the end of this chapter. The CE mark is displayed on the EC Declaration of Conformity (EMC Directive) provided at the end of this chapter.

### ■ Customer Responsibility

You intend to use the unit as a *component*, therefore you have a choice:

1. To fit the specified filter following EMC installation instructions, which may help you gain EMC compliance for the final machine/system.
2. Not to fit the specified filter, but use a combination of global or local filtering and screening methods, natural migration through distance, or the use of distributed parasitic elements of the existing installation.

**Note:** When two or more EMC compliant components are combined to form the final machine/system, the resulting machine/system may no longer be compliant, (emissions tend to be additive, immunity is determined by the least immune component). Understand the EMC environment and applicable standards to keep additional compliance costs to a minimum.

## Applying for CE Marking for EMC

We have supplied a Manufacturer's EMC Declaration at the end of this chapter that you can use as a basis for your own justification of overall compliance with the EMC directive. There are three methods of demonstrating conformity:

1. Self-certification to a relevant standard
2. Third party testing to a relevant standard
3. Writing a technical construction file stating the technical rationale as to why your final machine/system is compliant. An EMC "competent body" must then assess this and issue a technical report or certificate to demonstrate compliance.  
Refer to Article 10(2) of Directive 89/336/EEC.

With EMC compliance, an EC Declaration of Conformity and the CE mark will be issued for your final machine/system.

**IMPORTANT:** Professional end users with EMC expertise who are using drive modules and cubicle systems defined as components who supply, place on the market or install the relevant apparatus must take responsibility for demonstrating EMC conformance and applying the CE mark and issuing an EC Declaration of Conformity.

## Which Standards Apply?

### Power Drive Product Specific or Generic Standards

The standards that may apply to this unit come under two broad categories:

1. Emission - these standards limit the interference caused by operating (this) drive module.
2. Immunity - these standards limit the effect of interference (on this unit) from other electrical and electronic apparatus.

Conformance can be demonstrated using the Generic Standards or the Product Specific Standard.

The following tables indicate, for the two methods of compliance, the standards that the unit may comply with if installed and used correctly.

## Generic Standards

Assuming installation to EMC instructions in this manual  
 "Filter" refers to a specified external filter.

Installation	Generic Standards		Unit used as Relevant Apparatus		Unit used as a Component	
			filter (EMC compliance)	no filter	filter (EMC compliance may be applied for)	no filter
			enclosure	enclosure	enclosure	enclosure
 Residential, supplied directly from public electricity supply Residential, supplied directly from public electricity supply	Immunity only	EN50082-1(1992) • see below for referenced standards	✓	✓	✓	✓
	<u>Radiated Emissions</u>	EN50081-1 (1992) Cubicle mount only	✓	✓	✓	✓
	<u>Conducted Emissions</u>	EN50081-1 (1992) Maximum 5m shielded motor cable only	✓		✓	
 Commercial and light industry, supplied directly from public electricity supply	Immunity only	EN50082-1(1992) • see below for referenced standards	✓	✓	✓	✓
	<u>Radiated Emissions</u>	EN50081-1 (1992) Cubicle mount only	✓	✓	✓	✓
	<u>Conducted Emissions</u>	EN50081-1 (1992) Maximum 5m shielded motor cable only	✓		✓	
 Industrial installation with a separate transformer station	Radiated RF Emission	EN55011 (Class A) or EN50081-2(1994)	✓	✓	✓	✓
	Conducted RF Emission	EN55011 (Class A) or EN50081-2(1994)	✓		✓	
	Immunity	EN50082-2 (1992) • see below for referenced standards	✓	✓	✓	✓

### • Standards for Immunity:

IEC1000-4-2	Electrostatic discharge (e.g. from electrostatically charged persons)
IEC1000-4-3	Electromagnetic fields (e.g. from portable telephones)
ENV50140:	Pulse Modulated Electromagnetic Field
ENV50141:	Radio-Frequency Common-mode

IEC1000-4-4:	Fast electrical transients (burst) (e.g. from opening contacts in inductive circuits)
IEC1000-4-5:	Voltage surges (e.g. on local lightning strikes)
IEC1000-4-8	Power Frequency Magnetic Field
IEC1000-4-11	Voltage Dips Short Interruptions and voltage variations

# 12-12 Certification for the Inverter

## Product Specific Standard EN61800-3

Assuming installation to EMC instructions in this manual

"Filter" refers to a specified external filter.

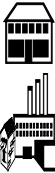
Installation	Sales	Performance Required		Unit used as Relevant Apparatus		Unit used as a Component	
				filter (EMC compliance)	no filter	filter (EMC compliance may be applied for)	no filter
				enclosure	enclosure	enclosure	enclosure
<b>FIRST ENVIRONMENT</b>  Environment includes domestic premises  Includes commercial and industrial installations supplied directly from public electricity supply which also supplies domestic premises	<i>Unrestricted Sales Distribution:</i>  Sales is not dependent on the EMC competence of the customer	Radiated RF Emission	Class A performance models rated >25A Class B performance models rated <25A *	✓	✓	✓	✓
		Conducted RF Emission	Class A performance models rated >25A Class B performance models rated <25A **	✓		✓	
	<i>Restricted Sales Distribution:</i> Sales restricted to customers with technical competence in EMC requirements of drives	Radiated RF Emission	Class A performance (all models)	✓	✓	✓	✓
		Conducted RF Emission	Class A performance (all models)	✓		✓	
		Immunity	• See below for referenced standards	✓	✓	✓	✓
<b>SECOND ENVIRONMENT</b>  All environments except domestic premises. All commercial, light industry and industrial installations, supplied from an intermediate transformer or directly from public electricity supply, which do not supply domestic premises.		RF Emission	EMC measures do not have to be implemented  If interference in a neighbouring installation occurs, the operator is responsible for taking measures to prevent interference. In this case the required emission levels must be adhered to at the point of supply to the affected neighbouring installation	✓	✓	✓	✓
		Immunity	• See below for referenced standards.	✓	✓	✓	✓

\* Cubicle mount only \*\* Maximum 5m shielded motor cable only

### • Standards for Immunity:

IEC1000-4-2	Electrostatic discharge (e.g. from electrostatically charged persons)	IEC1000-4-9	Pulsed magnetic field
IEC1000-4-3/6	Electromagnetic fields (e.g. from portable telephones)	IEC1000-4-11	Voltage Dips Short Interruptions and voltage variations
IEC1000-4-4	Fast electrical transients (burst) (e.g. from opening contacts in inductive circuits)	IEC1000-4-13*	Harmonics and interharmonics
IEC1000-4-5	Voltage surges (e.g. on local lightning strikes).	IEC1000-4-14*	Mains Voltage Fluctuations
IEC1000-4-8	Power Frequency Magnetic Field	IEC1000-4-16	Power Frequency Common mode
		IEC1000-4-27*	Unbalance

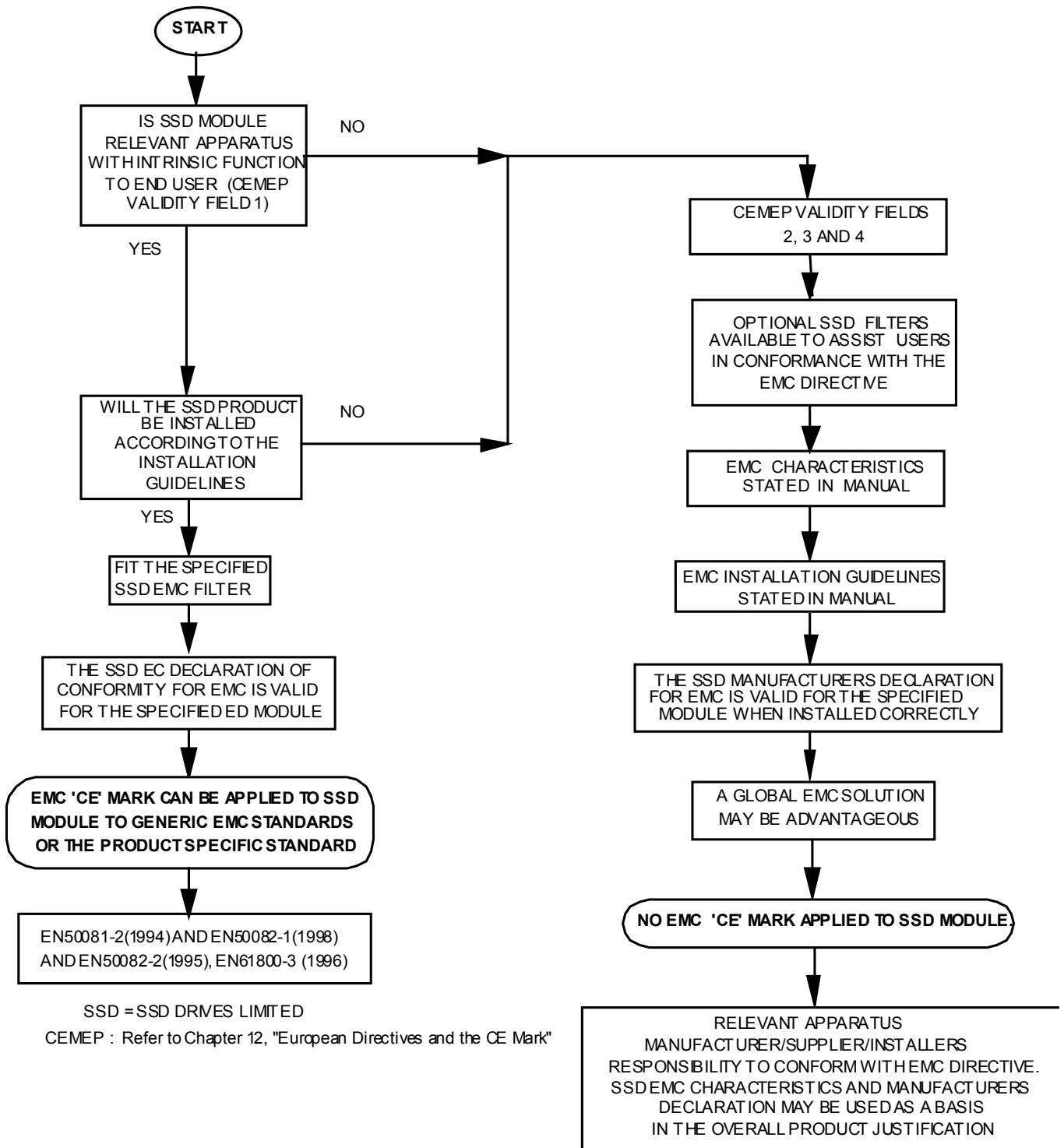



Figure 12-3 SSD Drives EMC 'CE' Mark Validity Chart

## Certificates

<b>605C</b>			
<b>(5.5kW - 11kW CONSTANT TORQUE / 7.5kW = 15kW QUADRATIC TORQUE)</b>			
<b>CE</b>		<b>EC DECLARATIONS OF CONFORMITY</b>	
Date CE marked first applied: 08.10.1996			
<b>EMC Directive</b>		<b>Low Voltage Directive</b>	
<p>In accordance with the EEC Directive 89/336/EEC and amended by 92/31/EEC and 93/68/EEC, Article 10 and Annex 1, (EMC DIRECTIVE)</p> <p>We SSD Drives Limited, address as below, declare under our sole responsibility that the above Electronic Products when installed and operated with reference to the instructions in the Product Manual (provided with each piece of equipment) is in accordance with the relevant clauses from the following standard:-</p> <p style="text-align: center;">* BSEN61800-3 (1997)</p>		<p>In accordance with the EEC Directive 73/23/EEC and amended by 93/68/EEC, Article 13 and Annex III, (LOW VOLTAGE DIRECTIVE)</p> <p>We SSD Drives Limited, address as below, declare under our sole responsibility that the above Electronic Products when installed and operated with reference to the instructions in the Product Manual (provided with each piece of equipment), is in accordance with the relevant clauses from the following standard :-</p> <p style="text-align: center;">EN50178 (1998)</p>	
<b>MANUFACTURERS DECLARATIONS</b>			
<b>EMC Declaration</b>		<b>Machinery Directive</b>	
<p>We SSD Drives Limited, address as below, declare under our sole responsibility that the above Electronic Products when installed and operated with reference to the instructions in the Product Manual (provided with each piece of equipment) is in accordance with the relevant clauses from the following standard:-</p> <p style="text-align: center;">* BSEN61800-3 (1997)</p>		<p>The above Electronic Products are components to be incorporated into machinery and may not be operated alone. The complete machinery or installation using this equipment may only be put into service when the safety considerations of the Directive 89/392/EEC are fully adhered to. Particular reference should be made to EN60204-1 (Safety of Machinery - Electrical Equipment of Machines). All instructions, warnings and safety information of the Product Manual must be adhered to.</p>	
 Dr Martin Payn (Conformance Officer)			
<p># Compliant with these immunity standards without specified EMC filters.</p>			
<p><b>SSD DRIVES LIMITED</b>                  NEW COURTWICK LANE, LITTLEHAMPTON, WEST SUSSEX BN17 7RZ                  TELEPHONE: 01903 737000 FAX: 01903 737100                  Registered Number: 1159876 England. Registered Office: Southdownview Way, Worthing, West Sussex BN14 8NN</p>			
<p>File Name: P:\PRODUCTS\CE\SAFETY\PRODUCTS\605C\LVD\PRODFILE\HK464337.919</p>			
ISS:	DATE	DRN: MP	CHKD: DRAWING NUMBER: HK464337.C919
B	22/11/2005		
TITLE:			SHT 1 OF 1 SHTS
Declarations of Conformity			

Issued for compliance with the EMC Directive when the unit is used as *relevant apparatus*.

This is provided to aid your justification for EMC compliance when the unit is used as a *component*.

The drive is CE marked in accordance with the low voltage directive for electrical equipment and appliances in the voltage range when installed correctly.

Since the potential hazards are mainly electrical rather than mechanical, the drive does not fall under the machinery directive. However, we do supply a manufacturer's declaration for when the drive is used (as a *component*) in machinery.

# APPLICATION NOTES

Application advice is available through our Technical Support Department, who can also arrange for on-site assistance if required. Refer to Chapter 8: “Routine Maintenance and Repair” for the address of your local SSD Drives company.

- Always use gold flash relays, or others designed for low current operation (5mA), on all control wiring.
- Remove all power factor correction equipment from the motor side of the Inverter before use.
- Avoid using motors with low efficiency and small  $\cos \phi$  (power factor) as they require a larger kVA rated Inverter to produce the correct shaft kW.

## Synchronous Motor Control

Although intended primarily for use with induction (asynchronous) motors, Inverters can also be used for speed control of synchronous motors. Synchronous motors can offer economic solutions in applications where tight control of speed is required together with the low maintenance characteristics of an ac motor.

The two most common types of synchronous ac motor are *permanent magnet* and *wound rotor*.

In contrast to induction motors, synchronous motors run at synchronous speed whether on full load or no load. Synchronous speed is set by the frequency of the supply applied to the stator. The stator flux can be kept constant by keeping the stator volts/frequency ratio constant, as with an induction motor.

Torque is produced in the motor by an increase in load angle between the stator and rotor fluxes. Maximum torque occurs when the load angle approaches  $90^\circ$ . If the load angle exceeds this value then torque drops and the motor will stall. Systems involving synchronous motors need careful design to ensure that the motor can accelerate the load and handle transient load changes without stalling.

## Brake Motors

Brake motors are used in applications requiring a mechanical brake for safety or other operational reasons. The motor can be a standard induction motor fitted with an electro-mechanical brake, or it could be a special conical rotor machine. In the case of a conical rotor machine the spring-loaded brake is controlled by the motor terminal voltage as follows:

- At rest the motor is braked.
- When the motor is energised an axial component of the magnetic field due to the conical air-gap overcomes the force of the brake spring and draws the rotor into the stator. This axial displacement releases the brake and allows the motor to accelerate like a normal induction motor.
- When the motor is de-energised the magnetic field collapses and the brake spring displaces the rotor, pushing the brake disc against the braking surface.

Inverters can be used to control the speed of conical rotor brake motors since the linear V/F characteristic maintains the motor magnetic field constant over the speed range. It will be necessary to set the FIXED BOOST parameter to overcome motor losses at low speed (see FLUXING menu at level 3).

## Using Line Chokes

Line chokes are not required to limit input current to SSD Drives Inverters. Controllers from 5.5kW (400v) or 2.2kW (230v) upwards are fitted with DC link chokes to limit the ripple current seen by the DC link capacitors and thus prolong their life.

## 13-2 Application Notes

Line chokes may be used to reduce the harmonic content of the supply current where this a particular requirement of the application or where greater protection from mains borne transients is required.

### Using Output Contactors

The use of output contactors is permitted. It is recommended that this type of operation be limited to emergency use only or in a system where the drive can be inhibited before closing or opening this contactor.

### Using Motor Chokes

Installations with motor cable runs in excess of 50m may suffer from nuisance overcurrent trips. This is due to the capacitance of the cable causing current spikes to be drawn from the Inverter output. A choke may be fitted in the Inverter output which limits the capacitive current. Screened cable has a higher capacitance and may cause problems in shorter runs. The recommended choke values are shown in Table A.1.

Motor Power (kW)	Choke Inductance	RMS Current Rating	SSD Drives Part No.
0.75	2mH	7.5A	CO055931
1.1			
1.5			
2.2			
4.0	0.9mH	22A	CO057283
5.5			
7.5			
11	0.45mH	33A	CO057284
15			
18	0.3mH	44A	CO057285
22	50uH	70A	CO055193
30			
37	50uH	99A	CO055253
45	50uH	99A	CO055253
55	25uH	120A	-
75	25uH	160A	-
90	25uH	200A	-

**Table 13-1 Recommended Choke Values for Cables up to 300 Metres**

## Using Multiple Motors on a Single Drive

A single large Inverter can be used to supply several smaller motors provided that each individual motor has overload protection.

**Note:** Conventional V/F control strategy must be enabled for use with parallel motors. (Sensorless vector control strategy cannot be used). See the VECTOR ENABLE parameter under VECTOR SET-UP menu at level 2.

The Inverter must be rated to supply the **total motor current**. It is not sufficient to simply sum the power ratings of the motors, since the Inverter has also to supply the magnetising current for each motor.

Note that the overload device will not prevent the motor overheating due to inadequate cooling at low speed. Force vented motors may be required; consult your motor supplier.

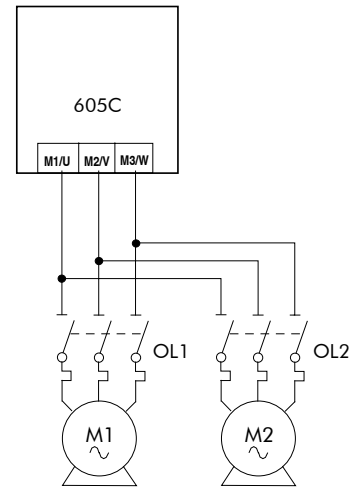

Figure 13-1 Single Inverter supplying multiple Motors

### WARNING!

All motors should be connected to the Inverter output before the START command is given.

### Caution

Restrict the total cable length on multiple motor installations as follows:

50 metres with no output choke fitted,  
300 metres with choke.

## Dynamic Braking

During deceleration, or with an overhauling load, the motor acts as a generator. Energy flows back from the motor into the dc link capacitors within the drive. This causes the dc link voltage to rise. If the dc link voltage exceeds 810V for the 400V build (or 890V for the 500V build) then the drive will trip to protect the capacitors and the Inverter power devices. The amount of energy that can be absorbed in the capacitors is relatively small; typically more than 20% braking

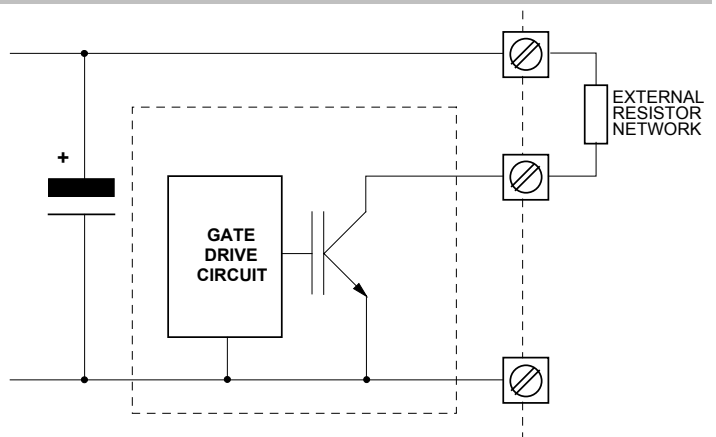

Figure 13-2 Dynamic Braking Circuit

torque will cause the drive to trip on overvoltage. Dynamic braking increases the braking capability of the drive by dissipating the excess energy in a high power resistor connected across the dc link, see above. Refer to Figure 3-9 for connection details.

# 13-4 Application Notes

The Dynamic Braking Option is a PCB with an extra IGBT power device fitted. It is fitted inside the drive package and is connected to the negative side of the dc link.

When the dc link voltage rises above 750V for the 400V build (815V for the 500V build), the brake unit switches the external resistor network across the dc link. The brake unit switches off again when the dc link voltage falls below the threshold level. The amount of energy produced by the motor during regeneration depends upon the DECEL RATE parameter (refer to the SYSTEM RAMP function block) and the inertia of the load.

All 605C units are supplied without braking resistors. The following paragraphs should be used as a guide to calculate the braking requirements of the system.

## Brake Resistor Selection

Brake resistor assemblies must be rated to absorb both peak braking power during deceleration and the average power over the complete cycle.

$$\text{Peak braking power} = \frac{0.0055J \times (n_1^2 - n_2^2)}{t_b} \quad (\text{W})$$

$$\text{Average braking power } P_{av} = \frac{P_{pk}}{t_c} \times t_b$$

- J - total inertia (kgm<sup>2</sup>)
- n<sub>1</sub> - initial speed (rpm)
- n<sub>2</sub> - final speed (rpm)
- t<sub>b</sub> - braking time (s)
- t<sub>c</sub> - cycle time (s)

Information on the peak power rating and the average power rating of the resistors must be obtained from the resistor manufacturer. Alternatively if this information is not available then a large safety margin must be incorporated to ensure that the resistors are not overloaded. SSD Drives can supply suitable brake resistor assemblies as detailed over.

By connecting these resistors in series and in parallel the braking capacity can be selected for the application.

The minimum resistance of the combination should not be less than that specified, refer to table 3.2.

The resistor(s) must be specified to the maximum dc link voltage (890V for the 500V build, 810V for the 400V build, 420V for the 230V build).

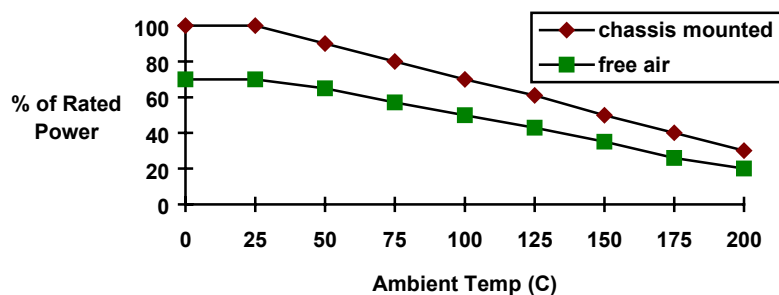

Figure 13-3 Brake Resistor Derating Graph

## High Starting Torque

---

Applications requiring high motor starting torque (greater than 100% of rated torque) need careful setup of the drive voltage boost feature. For most motors, a FIXED BOOST parameter (FLUXING function block) setting of 6.0% is usually adequate. Setting the FIXED BOOST parameter level too high can cause the drive current limit feature to operate. If this occurs, the drive will be unable to ramp up in frequency. The LIMITING diagnostic (CURRENT LIMIT function block) will indicate TRUE when the current limit feature is operating. Simply reducing the level of the FIXED BOOST parameter will remove this problem. It is important to use the minimum level of FIXED BOOST necessary to accelerate the load. Using a level of FIXED BOOST higher than necessary will lead to increased motor heating and increased risk of drive overload.

**Note:** *Motor torques greater than 100% require high currents to be drawn from the drive. Thus, the MOTOR I LIMIT parameter (CURRENT LIMIT function block) will have to be set accordingly such that the drive current limit feature will not activate when accelerating the load.*

The best motor starting performance can be achieved by setting up the SLIP COMP function block, refer to Chapter 6: SLIP COMP. Also setting the BASE VOLTS parameter (VOLTAGE CONTROL function block) to 115.4% and the SWITCHING FREQ parameter (PATTERN GEN function block) to 3kHz, can help to start difficult loads in the most extreme cases.

# 13-6 Application Notes

# SERIAL COMMUNICATIONS

## Communications Technology Option

The plug-in COMMS Technology Option provides a serial data port, allowing Inverters to be linked to form a network. Using a PLC/SCADA or other intelligent device, this network can be continuously controlled to provide supervision and monitoring for each Inverter in the system.

Refer to the Communications Interface Technical Manual for further details.

### ConfigEd Lite

This is SSD Drives' Windows-based block programming software. It has a graphical user-interface and drawing tools to allow you to create block programming diagrams quickly and easily. Contact your local SSD Drives sales office.

## Connection to the P3 Port

There are two P3 ports; one is on the front of the unit (used by the fixed Operator Station), and the second is on the Control Board.

Using the P3 port on the Inverter, parameters can be monitored and updated by a suitable PC programming tool.

The port is an un-isolated RS232, 19200 Baud, supporting the standard EI bisynch ASCII communications protocol. Contact SSD Drives for further information.

### P3 Port

A standard P3 lead is used to connect to the Inverter.

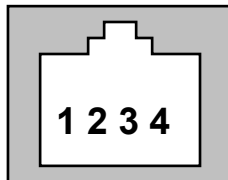

P3 Port Pin	Lead	Signal
1	Black	0V
2	Red	5V
3	Green	TX
4	Yellow	RX

### 6-Way Lead to DB9/DB25 Connector

**Note:** There is 5V present on pin 2 of the P3 port - do not connect this to your PC.

P3 Port Pin	Lead	Female DB9 Pin	Female DB25 Pin
1	Black	5	7
2	Red	not connected	not connected
3	Green	2	3
4	Yellow	3	2

# 14-2 Serial Communications

# APPLICATION MACROS

## The Default Application

The Inverter is supplied with 8 macros, Macro 0 to Macro 6 and Macro 99. Each macro recalls a pre-programmed set of parameters when it is loaded.

- Macro 1 is the factory default macro, providing for basic speed control
- Macro 2 supplies speed control with Run Forward/Run Reverse
- Macro 3 is a set-up providing speed control with Raise/Lower Trim
- Macro 4 is for PID process control
- Macro 5 supplies speed control using preset speeds
- Macro 6 is a set-up using closed-loop speed feedback
- Macro 99 provides speed control with 584S terminal allocation

**Note:** To return to the default application, perform the Quick Restore Default procedure, refer to Chapter 5: “The Operator Station” - Menu Shortcuts and Special Key Combinations.

## How to Load a Macro

**MMI Menu Map**

1	SYSTEM
2	RESTORE DEFAULTS
3	MACRO 1
3	MACRO 2
3	MACRO 3
3	MACRO 4
3	MACRO 5
3	MACRO 6
3	MACRO 99
3	MACRO 0

In the OPERATOR menu, go to the RESTORE DEFAULTS menu at level 2, press the **M** key.

The macros are stored in this menu.

Use the up (**Δ**) and down (**∇**) keys to select the appropriate macro, press the **M** key.

Pressing the up (**Δ**) key as instructed, loads the macro.

Now update the non-volatile memory within the Inverter by performing a SAVE TO MEMORY. Refer to Chapter 5: “The Operator Station” - Saving Your Application.

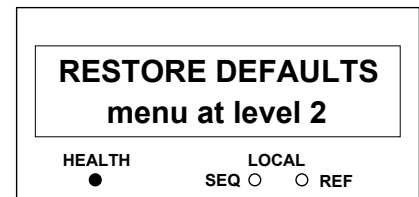

## Macro Descriptions

**Note:** Parameters whose default values are product-related are indicated in the block diagrams with \* or \*\*. Refer to Chapter 2: “An Overview of the Inverter” - Product-Related Default Values.

### Macro 0

This macro will not control a motor.

It is included to document the differences between all the configurations, using this as the baseline.

Loading Macro 0 removes all internal links, and sets all parameter values to the values defined for each function block in Chapter 6: Programming Your Application.

## 15-2 Application Macros

### The **OPERATOR** Menu for Macro 0

The default OPERATOR menu is shown below.

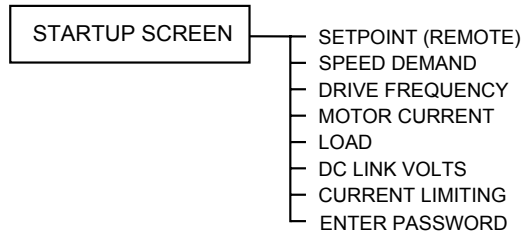

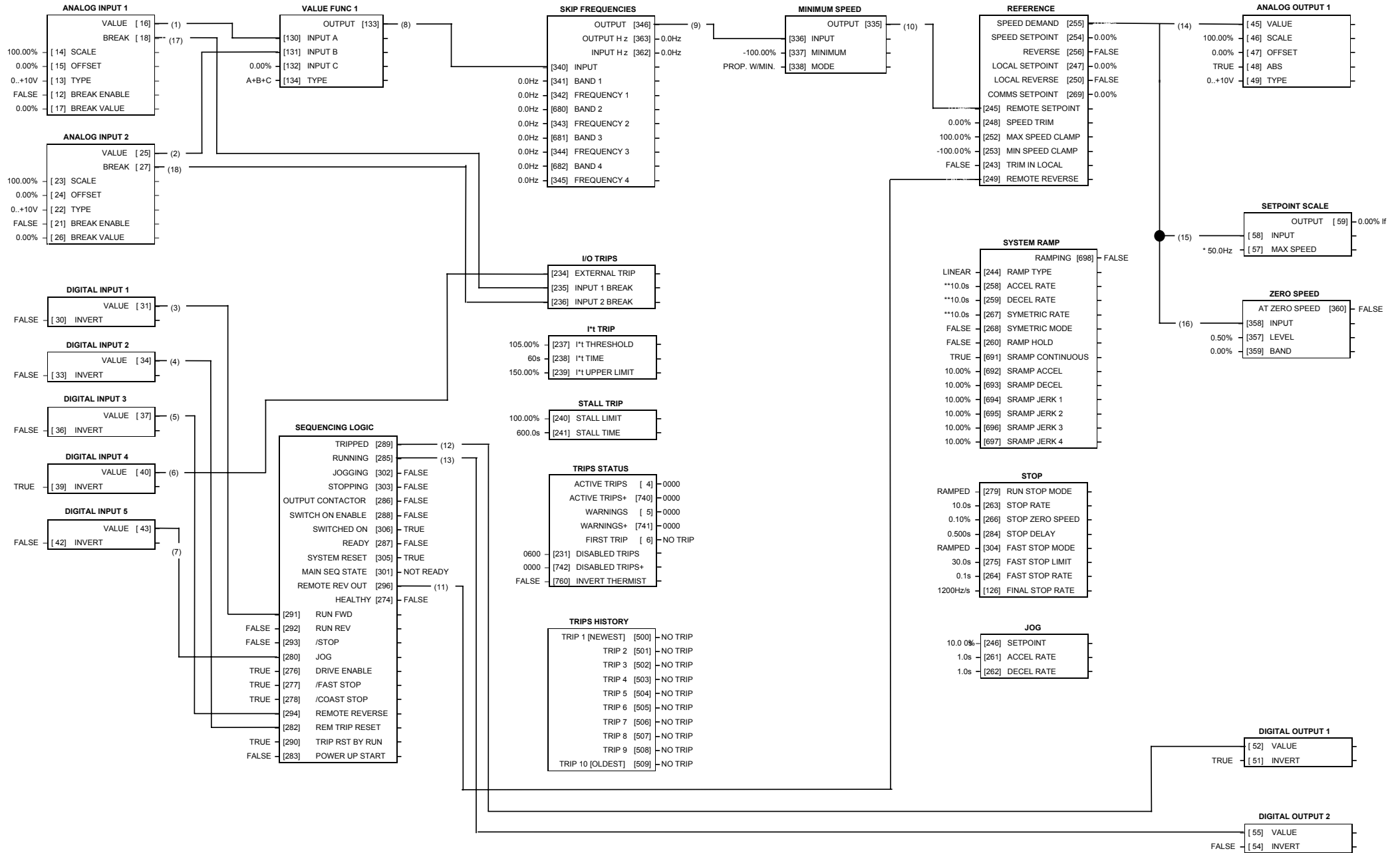

**Macro 1: Basic Speed Control (default)**

**Macro 1: Basic Speed Control (default)**

This macro provides standard control of the inverter.

Control Wiring I/O			
Terminal	Name	Purpose	Comment
1	ANALOG INPUT 1	Setpoint	0V = 0%, 10V = 100%
2	ANALOG INPUT 2	Setpoint Trim	0V = 0%, 10V = 100%
6	ANALOG OUTPUT 1	Ramp Output	Absolute Speed Demand 0V = 0%, 10V = 100%
13	DIGITAL INPUT 1	Run	24V = Run
14	DIGITAL INPUT 2	Trip Reset	0V to 24V transition to reset trips.
15	DIGITAL INPUT 3	Direction	0V = Forward, 24V = Reverse
16	DIGITAL INPUT 4	External Trip	0V = Trip (connect to terminal 18)
17	DIGITAL INPUT 5	Jog	24V = Jog
21, 22	DIGITAL OUTPUT 1	Health	0V = Tripped, i.e. not healthy
23, 24	DIGITAL OUTPUT 2	Running	0V = Stopped, 24V = Running

**The Operator Menu System for Macro 1**

The default Operator menu system is shown below.

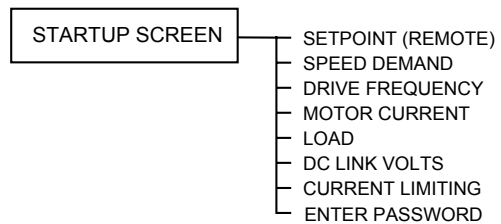

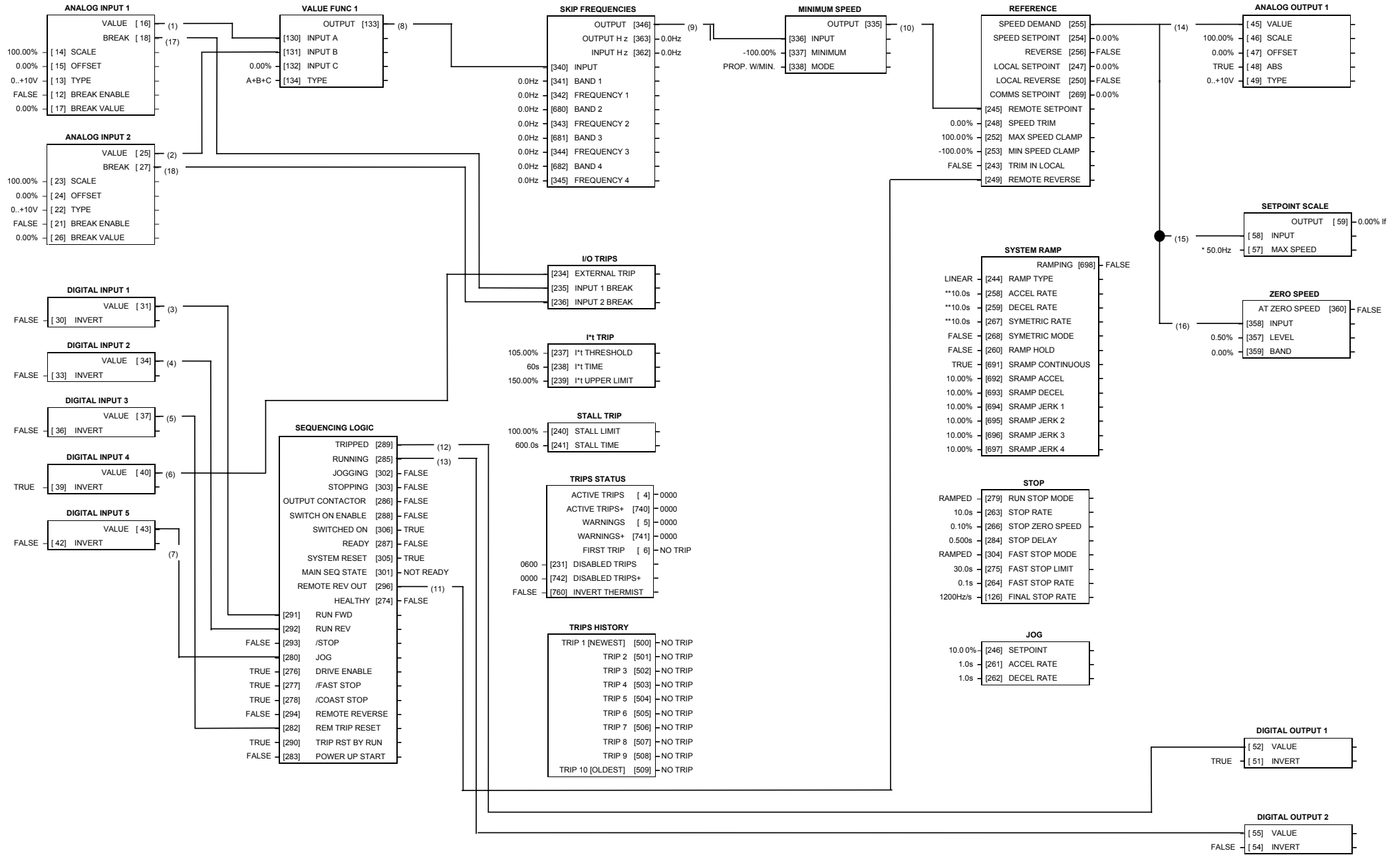

**Macro 2: Run Forward/Run Reverse**

**Macro 2: Run Forward/Run Reverse**

Same as Macro 1 except the sequencing is controlled by Run Forward and Run Reverse digital inputs.

Terminal	Name	Purpose	Comment
1	ANALOG INPUT 1	Setpoint	0V = 0%, 10V = 100%
2	ANALOG INPUT 2	Setpoint Trim	0V = 0%, 10V = 100%
6	ANALOG OUTPUT 1	Ramp Output	Absolute Speed Demand, 0V = 0%, 10V = 100%
13	DIGITAL INPUT 1	Run Forward	24V = Run Forward
14	DIGITAL INPUT 2	Run Reverse	24V = Run Reverse
15	DIGITAL INPUT 3	Trip Reset	0V to 24V transition to reset trips
16	DIGITAL INPUT 4	External Trip	0V = Trip (connect to terminal 18)
17	DIGITAL INPUT 5	Jog	24V = Jog
21, 22	DIGITAL OUTPUT 1	Health	0V = Tripped, i.e. not healthy
23, 24	DIGITAL OUTPUT 2	Running	0V = Stopped, 24V = Running

**The Operator Menu System for Macro 2**

The default Operator menu system is shown below.

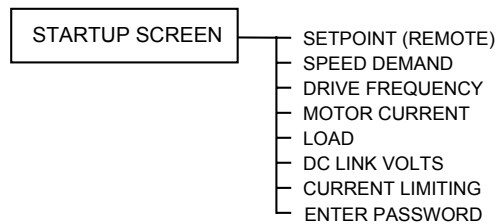



### Macro 3: Raise/Lower Trim

This macro provides a raise/lower (push button) interface for an additional Setpoint Trim. The Setpoint is derived from the sum of ANALOG INPUT 1, ANALOG INPUT 2 and the output of the raise/lower ramp. This ramp is controlled by the 3 digital inputs RAISE INPUT, LOWER INPUT and RESET of the RAISE/LOWER function block.

The raise/lower trim is restricted to be +/- 10.00%. This limit is set by the MIN VALUE and MAX VALUE parameters in the RAISE/LOWER function block.

Note that the raise/lower ramp output is automatically preserved in non-volatile memory during a power-down.

Terminal	Name	Purpose	Comment
1	ANALOG INPUT 1	Setpoint	0V = 0%, 10V = 100%
2	ANALOG INPUT 2	Setpoint Trim	0V = 0%, 10V = 100%
6	ANALOG OUTPUT 1	Ramp Output	Absolute Speed Demand, 0V = 0%, 10V = 100%
13	DIGITAL INPUT 1	Run	24V = Run
14	DIGITAL INPUT 2	Raise	24V = Ramp Up
15	DIGITAL INPUT 3	Lower	24V = Ramp Down
16	DIGITAL INPUT 4	External Trip	0V = Trip (connect to terminal 18)
17	DIGITAL INPUT 5	Reset	24V = Reset and Hold Raise Lower
21, 22	DIGITAL OUTPUT 1	Health	0V = Tripped, i.e. not healthy
23, 24	DIGITAL OUTPUT 2	Running	0V = Stopped, 24V = Running

### The Operator Menu System for Macro 3

The default Operator menu system is shown below.

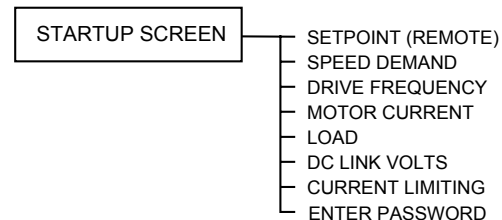

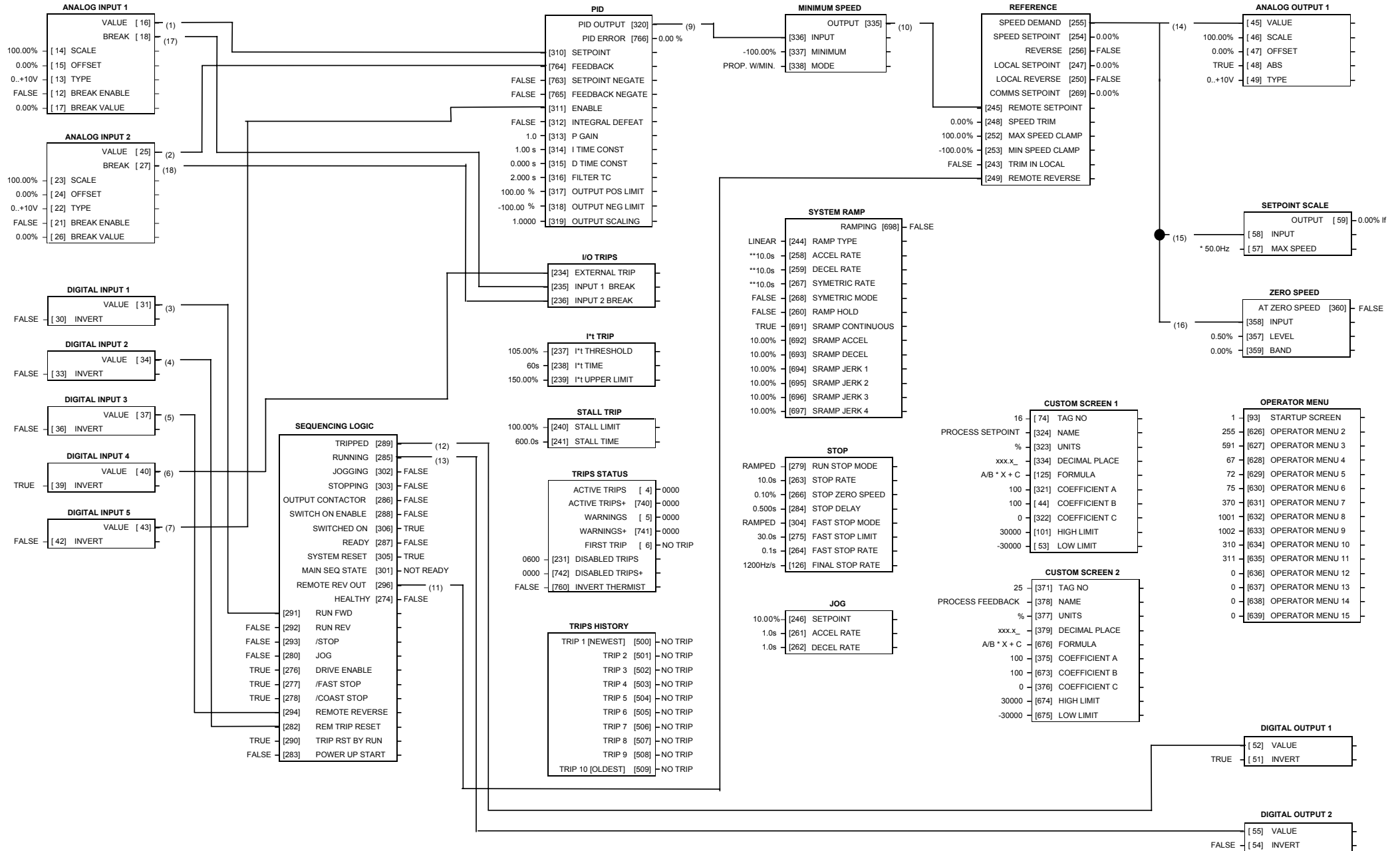

**Macro 4: Process PID**

**Macro 4: Process PID**

PID error derived from the difference of 2 analog inputs.

Digital input to disable PID.

Additional Operator Menu display parameters.

Terminal	Name	Purpose	Comment
1	ANALOG INPUT 1	Process Setpoint	0V = 0%, 10V = 100%
2	ANALOG INPUT 2	Process Setpoint Trim	0V = 0%, 10V = 100%
6	ANALOG OUTPUT 1	Ramp Output	Absolute Speed Demand, 0V = 0%, 10V = 100%
13	DIGITAL INPUT 1	Run	24V = Run
14	DIGITAL INPUT 2	Trip Reset	0V to 24V transition to reset trips.
15	DIGITAL INPUT 3	Direction	0V = Forward, 24V = Reverse
16	DIGITAL INPUT 4	External Trip	0V = Trip (connect to terminal 18)
17	DIGITAL INPUT 5	PID Enable	0V = PID Disabled, 24V = PID Enabled
21, 22	DIGITAL OUTPUT 1	Health	0V = Tripped, i.e. not healthy
23, 24	DIGITAL OUTPUT 2	Running	0V = Stopped, 24V = Running

**The Operator Menu System for Macro 4**

The default Operator menu system is shown below.

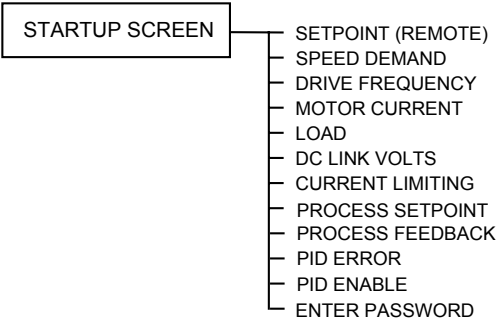

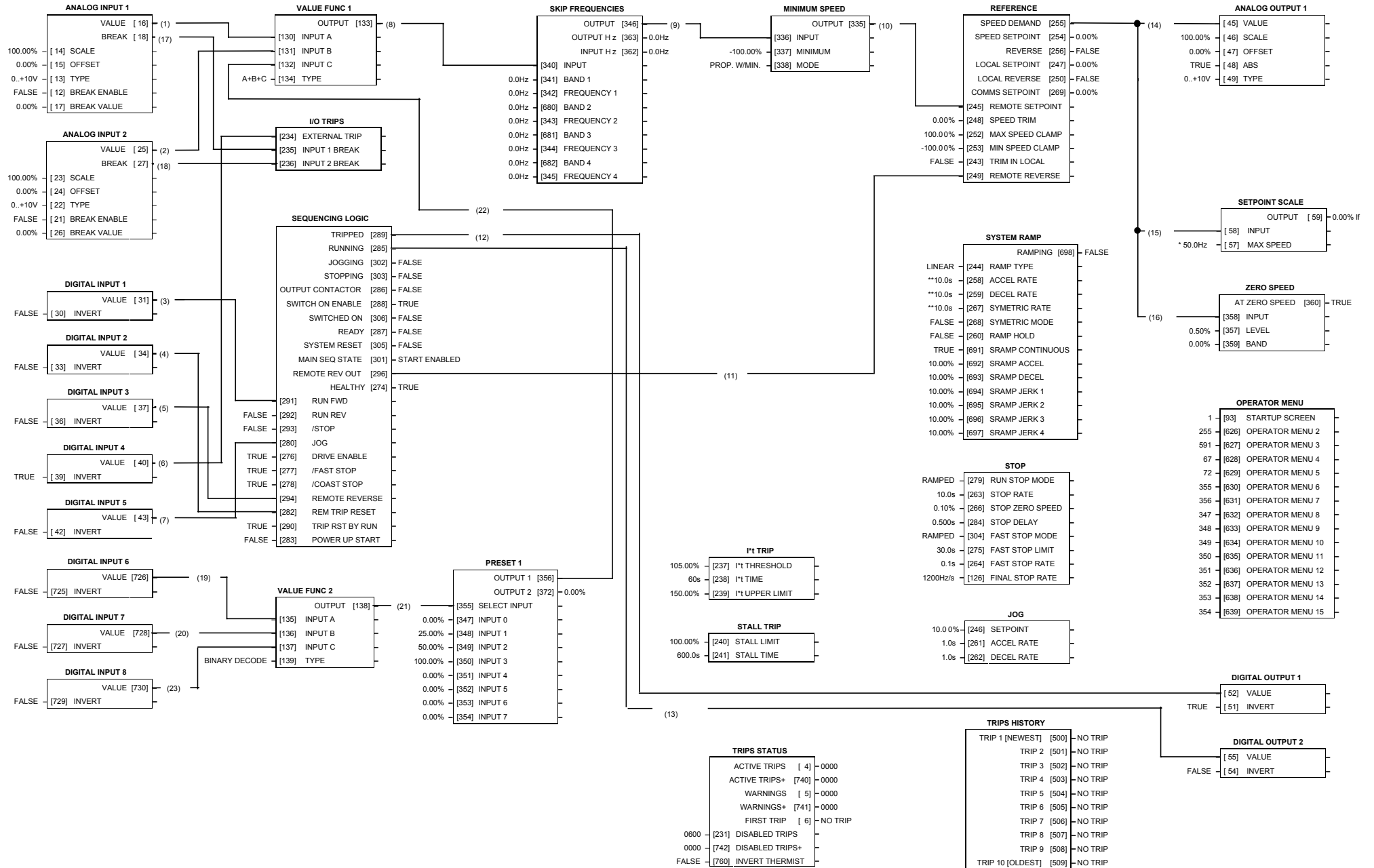

Macro 5: Preset Speeds

**Macro 5: Preset Speeds**

Digital inputs select up to 8 preset speeds.  
 Additional Operator Menu display parameters.

Terminal	Name	Purpose	Comment
1	ANALOG INPUT 1	Setpoint	0V = 0%, 10V = 100%
2	ANALOG INPUT 2	Setpoint Trim	0V = 0%, 10V = 100%
6	ANALOG OUTPUT 1	Ramp Output	Absolute Speed Demand, 0V = 0%, 10V = 100%
13	DIGITAL INPUT 1	Run	24V = Run
14	DIGITAL INPUT 2	Trip Reset	0V to 24V transition to reset trips.
15	DIGITAL INPUT 3	Direction	0V = Forward, 24V = Reverse
16	DIGITAL INPUT 4	External Trip	0V = Trip (connect to terminal 18)
17	DIGITAL INPUT 5	PID Enable	0V = PID Disabled, 24V = PID Enabled
18	DIGITAL INPUT 6	Preset 1	Preset Speed Select
19	DIGITAL INPUT 7	Preset 2	Preset Speed Select
20	DIGITAL INPUT 8	Preset 3	Preset Speed Select
21, 22	DIGITAL OUTPUT 1	Health	0V = Tripped, i.e. not healthy
23, 24	DIGITAL OUTPUT 2	Running	0V = Stopped, 24V = Running

**The Operator Menu System for Macro 5**

The default Operator menu system is shown below.

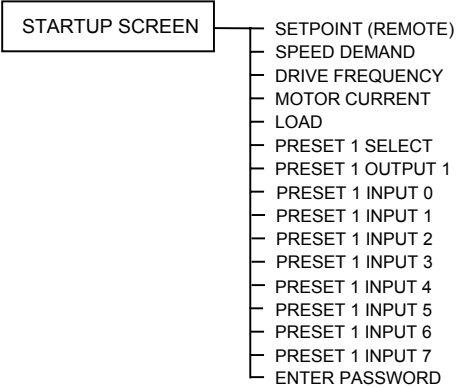

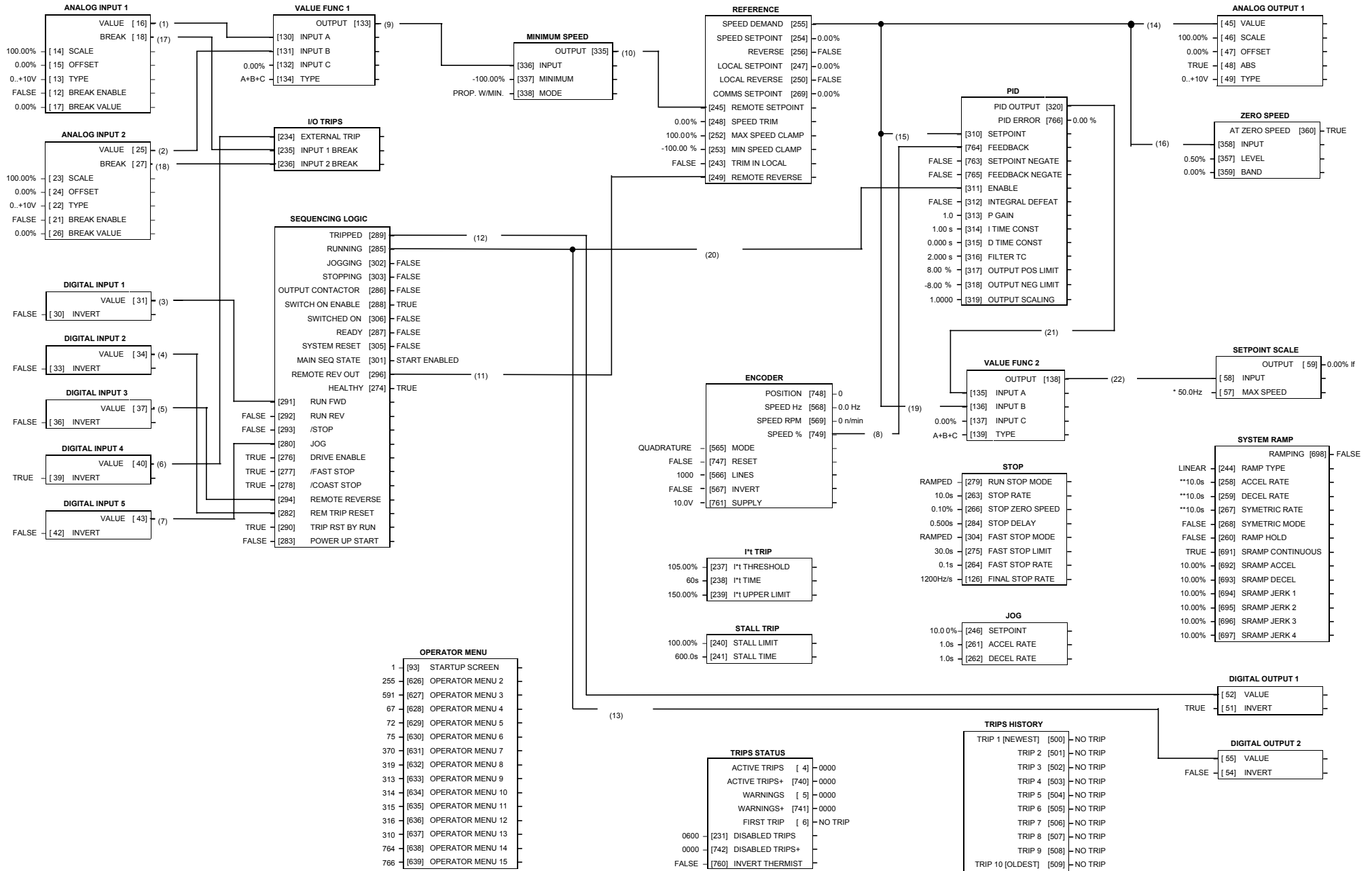

### Macro 6: Closed-Loop Speed Feedback

**Macro 6: Closed-Loop Speed Feedback**

Encoder speed feedback.

PID speed regulation loop.

Additional Operator Menu display parameters.

Terminal	Name	Purpose	Comment
1	ANALOG INPUT 1	Setpoint	0V = 0%, 10V = 100%
2	ANALOG INPUT 2	Setpoint Trim	0V = 0%, 10V = 100%
6	ANALOG OUTPUT 1	Ramp Output	Absolute Speed Demand, 0V = 0%, 10V = 100%
13	DIGITAL INPUT 1	Run	24V = Run
14	DIGITAL INPUT 2	Trip Reset	0V to 24V transition to reset trips.
15	DIGITAL INPUT 3	Direction	0V = Forward, 24V = Reverse
16	DIGITAL INPUT 4	External Trip	0V = Trip (connect to terminal 18)
17	DIGITAL INPUT 5	PID Enable	0V = PID Disabled, 24V = PID Enabled
21, 22	DIGITAL OUTPUT 1	Health	0V = Tripped, i.e. not healthy
23, 24	DIGITAL OUTPUT 2	Running	0V = Stopped, 24V = Running

**The Operator Menu System for Macro 6**

The default Operator menu system is shown below.

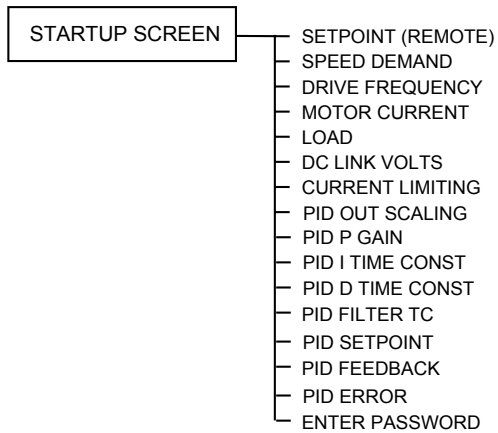

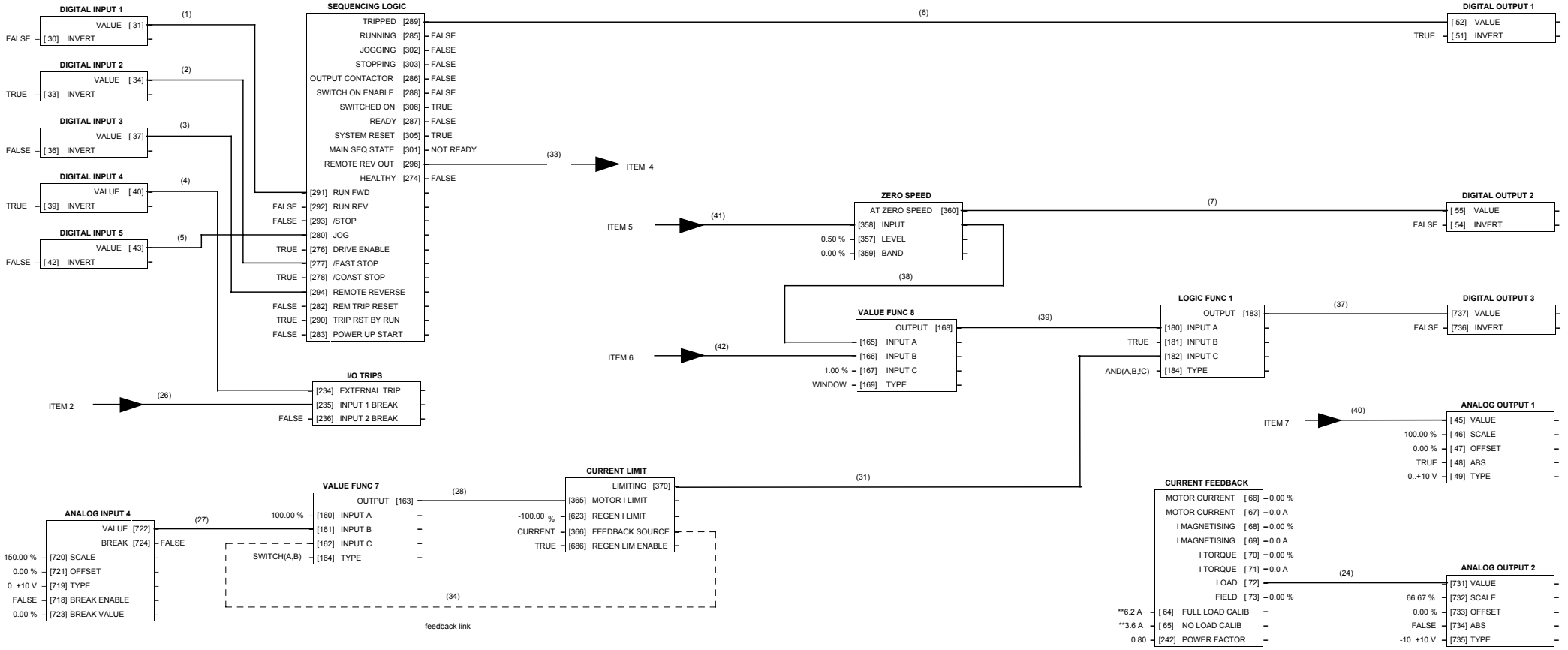

**Macro 99: 584S Compatible Application**

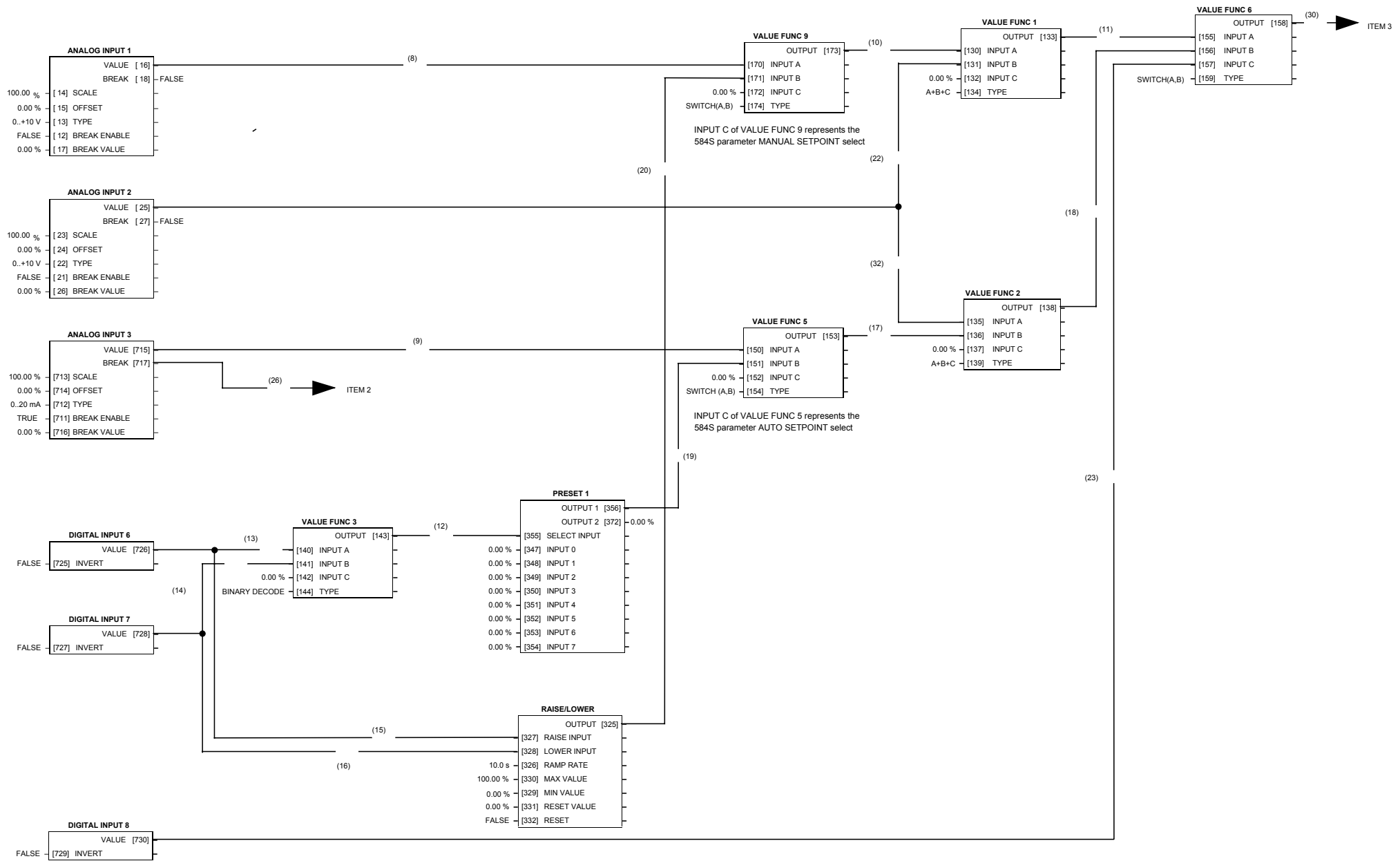

## Macro 99: 584S Compatible Application

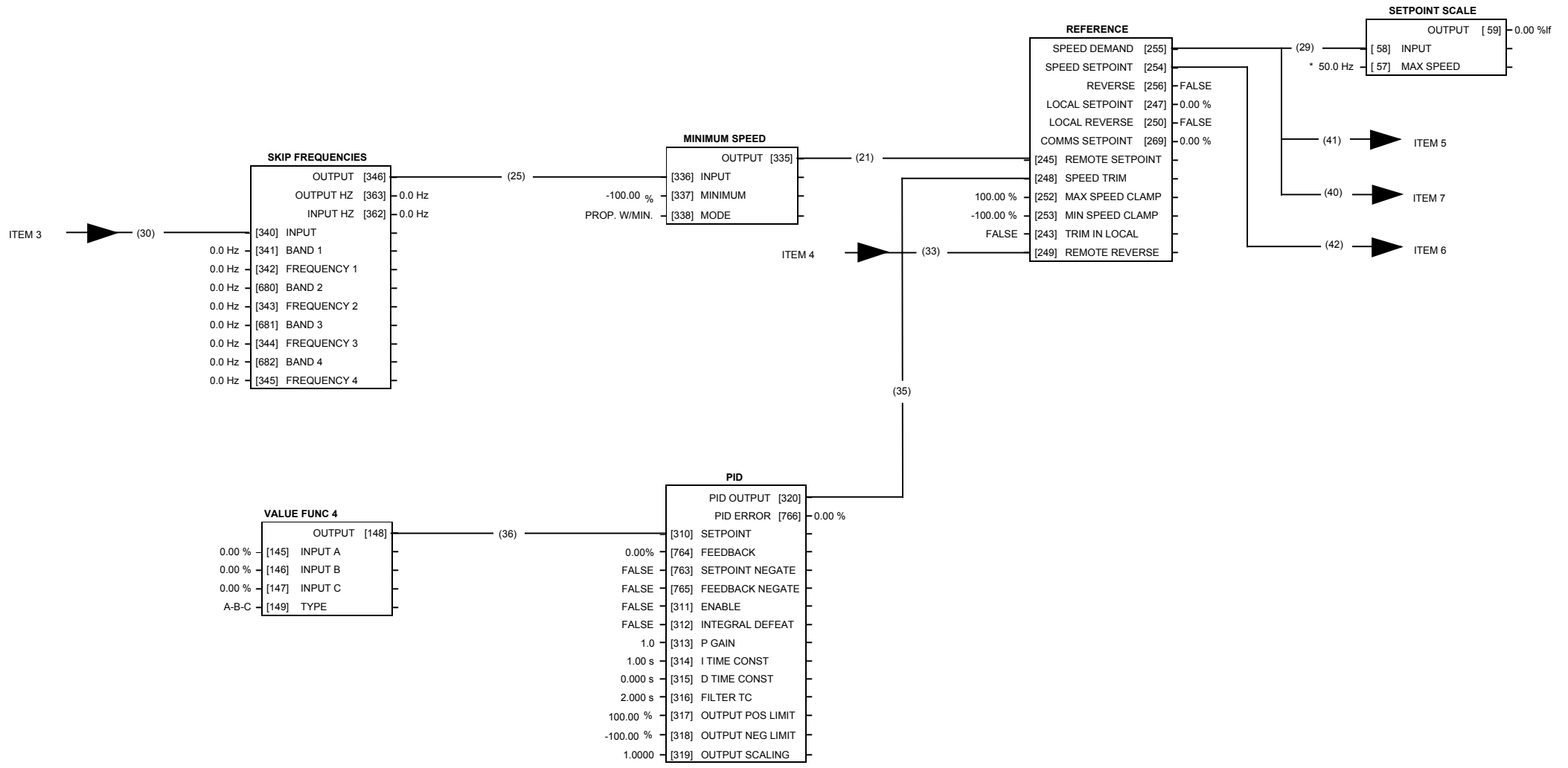

**Macro 99: 584S Compatible Application**

### Macro 99: 584S Compatible Application

This macro provides terminal allocation and block diagram functionality compatible with the 584S product.

Terminal	Name	Purpose	Comment
1	ANALOG INPUT 1	Setpoint	0V = 0%, 10V = 100%
2	ANALOG INPUT 2	Setpoint Trim	0V = 0%, 10V = 100%
3	ANALOG INPUT 3	Current Loop Setpoint	0mA = 0%, 20mA = 100%
5	ANALOG INPUT 4	Torque Limit Setpoint	0V = 0%, 10V = 150%
6	ANALOG OUTPUT 1	Ramp Output	Absolute Speed Demand 0V = 0%, 10V = 100%
7	ANALOG OUTPUT 2	Load Output	-10V = -150%, 10V = 150%
13	DIGITAL INPUT 1	Run	24V = Run
14	DIGITAL INPUT 2	Fast Stop	0V - Fast Stop
15	DIGITAL INPUT 3	Direction	0V = Forward, 24V = Reverse
16	DIGITAL INPUT 4	External Trip	0V = Trip (connect to terminal 18)
17	DIGITAL INPUT 5	Jog	24V = Jog
18	DIGITAL INPUT 6	Preset 1	Preset Speed Select
19	DIGITAL INPUT 7	Preset 2	Preset Speed Select
20	DIGITAL INPUT 8	Manual/Auto	0V = Manual Setpoint 24V = Auto Setpoint
21, 22	DIGITAL OUTPUT 1	Health	Relay closed = drive healthy
23, 24	DIGITAL OUTPUT 2	Zero Speed	Relay closed = drive at zero speed
25, 26	DIGITAL OUTPUT 3	At Speed	Relay closed = drive at speed setpoint

### The Operator Menu System for Macro 99

The default Operator menu system is shown below.

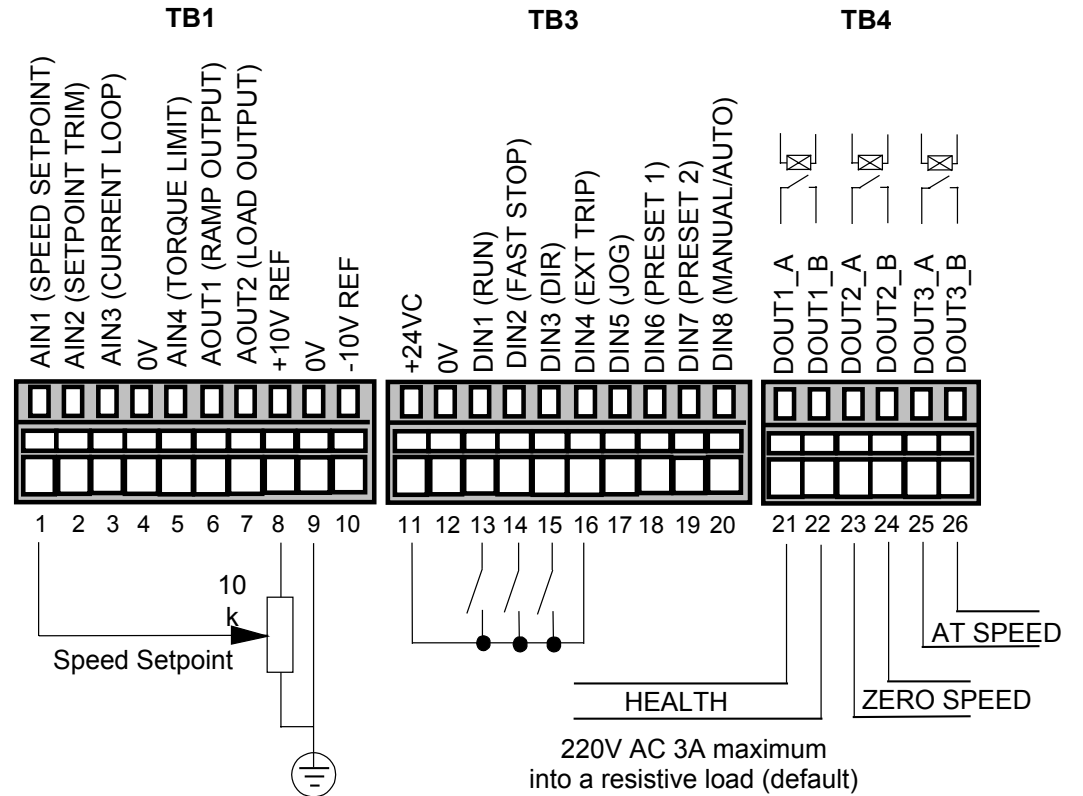
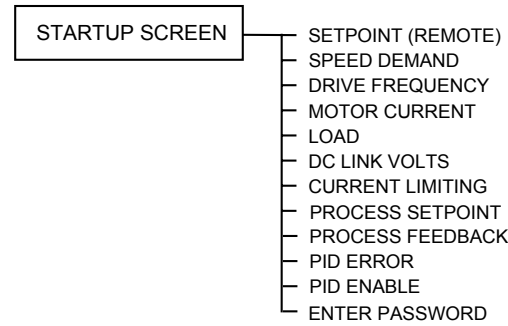

General Wiring Diagram for Macro 99



**Macro Control Blocks** Some of these blocks may already be in use by the macros.

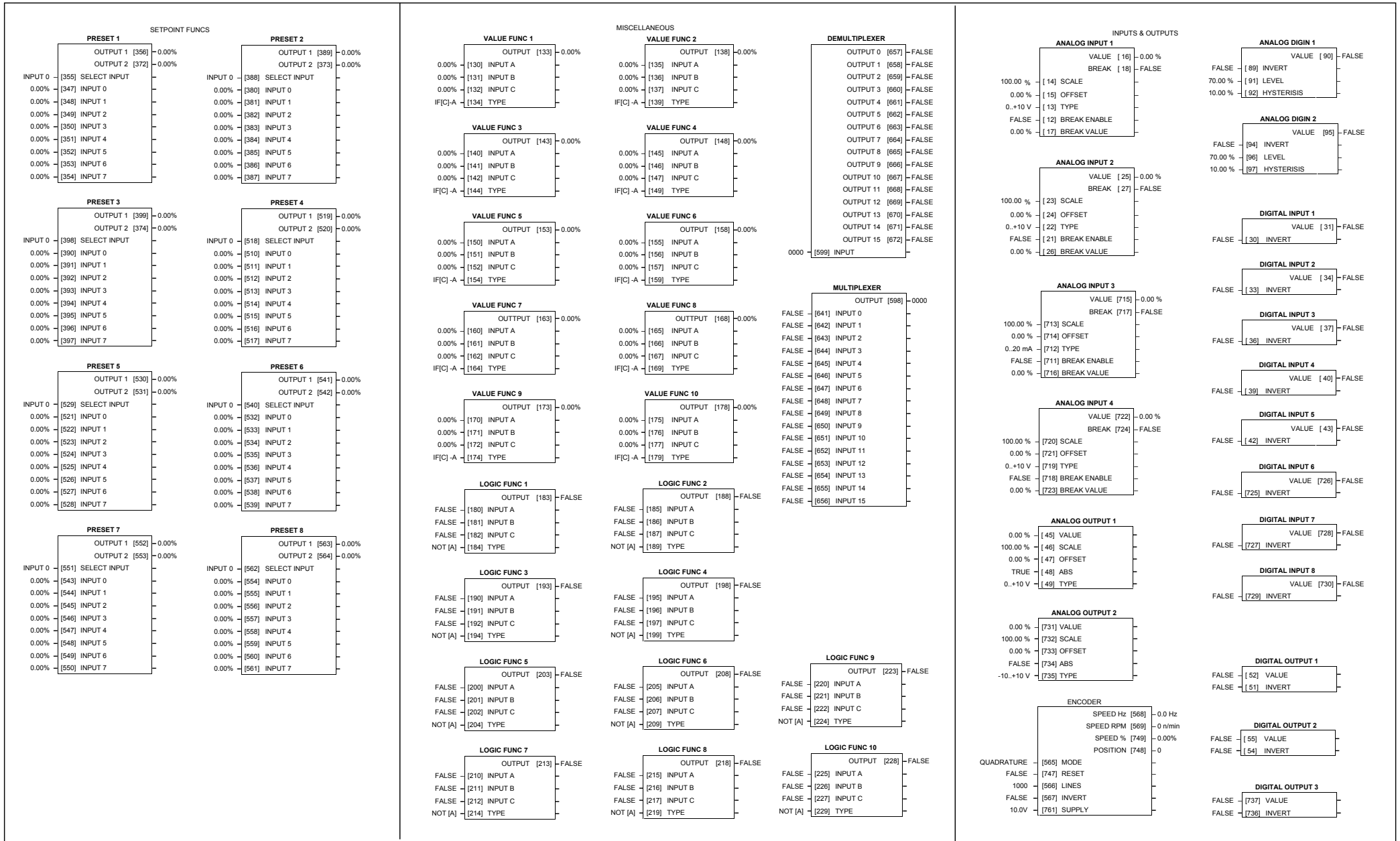

**Macro User Blocks** some of these blocks may already be in use by the macros.

ISS.	MODIFICATION	ECN No.	DATE	DRAWN	CHK'D
1	Initial Issue (HA465013U001)	12251	1/4/99	CM	BB
2	Chapter 9 and Macros 5 & 6 re-worked. Other small improvements.	13503	1/5/99	CM	KJ
3	Configuration switch SW1 re-tracked. New information on page 6-10.	13545	14/5/99	CM	SS
4	Updated to Version 5.2 Software. Various other small amendments. Page 1-1 Added Important note. Chapter 12 Replaced Certificates with new formatted version. Page 2-4 Removed option B1 from block 8. Page 6-19 Replaced MOTOR CURRENT with I MAGNETISING under FIELD parameter. Page 7-2 Changed terminal 23 to terminal 16.	13746 13714 13749 13788 13726	13/9/99	CM	KJ
5	MMI Diagnostic Information added to Chapter 5 Change to "Solid-State Motor Overload Protection" and "Short Circuit Rating", Figure 3-8 has note added to thermistor, Notes added underneath VALUE FUNC 9 and VALUE FUNC 5 function blocks in Macro 99, Chapter 15. Various other small amendments	13557 (13951) (15570) (15696)	27/11/00	CM	FP
6	Vibration details added, page 11-1 Motor choke detail added, page 3-13 Quick-Start Guide added, page 11-1	16024 (16318)	25/7/02	CM	FP
7	New details added for 6901 Operator Station, pages 3-7, 3-8, 5-1, 5-2.	17647	7/7/03	CM	KS
8	Company name change	18354	22/11/05	CM	KS
FIRST USED ON		MODIFICATION RECORD			
		605C Frequency Inverter			
		DRAWING NUMBER			SHT. 1
		ZZ465013C001			OF 1

