

H Series Hydraulic Cylinder

Catalog M1112

October, 2003

OBSOLETE



Nominal Pressure 3000 PSI
Bore Sizes 1½" through 20"
NFPA Interchangeable



AV Series Cylinders
Up to 250 PSI Permanently Lubricated



Series AV air cylinders are available in bore sizes from 1-1/2" through 14" and up to 250 PSI operating pressure. Standard NFPA dimensions and proven Miller design features.

BT & BTM Series Cylinders
Up to 250 PSI



Our BT & BTM Series Air Cylinders are available in bore sizes from 5/16" through 3". Operating pressures up to 250 PSI. 28 available mounting styles.

IPA Series Cylinders
10 BAR



Up to 10 BAR pressure. Bore sizes 32mm through 200mm. Meets and approved to GM pneumatic cylinder specifications CC-001. VDMA 24562 and ISO 6431 compatible.

HV2 Series Cylinders
3000 PSI



Miller's heavy-duty cylinder line for demanding hydraulic applications. Bore sizes from 1-1/2" to 8".

Warning

FAILURE OR IMPROPER SELECTION OR IMPROPER USE OF THE PRODUCTS AND/OR SYSTEMS DESCRIBED HEREIN OR RELATED ITEMS CAN CAUSE DEATH, PERSONAL INJURY AND PROPERTY DAMAGE.

This document and other information from The Company, its subsidiaries and authorized distributors provide product and/or system options for further investigation by users having technical expertise. It is important that you analyze all aspects of your application, including consequences of any failure and review the information concerning the product or system in the current product catalog. Due to the variety of operating conditions and applications for these products or systems, the user, through its own analysis and testing, is solely responsible for making the final selection of the products and systems and assuring that all performance, safety and warning requirements of the application are met.

The product described herein, including without limitation, product features, specifications, designs, availability and pricing, are subject to change by The Company and its subsidiaries at any time without notice.

Offer of Sale

The items described in this document are hereby offered for sale by The Company, its subsidiaries or its authorized distributors. This offer and its acceptance are governed by provisions stated on a separate page of this catalog in the document entitled "Offer of Sale".

Miller H Series Hydraulic Cylinders

Table Of Contents

Hydraulic Cylinder Features	2-3
Mounting Styles.....	4-5
1½"-20" Bore Cylinder Reference Chart.....	6-7
Cylinder Mountings (1½"-8" Bores)	8-43
Model 50 Series, Tie Rods Extended	8-9
Model 61, Rectangular Flange - Head End.....	10-11
Model 62, Rectangular Flange - Cap End.....	12-13
Model 65, Square Flange - Head End	14-15
Model 66, Square Flange - Cap End	16-17
Model 67 & 68, Rectangular Head or Cap	18-19
Model 72, Side Lugs	20-21
Model 73, Centerline Lugs.....	22-23
Model 74, Side Tapped.....	24-25
Model 77, End Lugs	26-27
Model 71, End Angles	28-29
Model 81, Trunnion - Head End.....	30-31
Model 82, Trunnion - Cap End.....	32-33
Model 89, Intermediate Trunnion	34-35
Model 84, Fixed Clevis.....	36-37
Model 86, Detachable Clevis	38-39
Model 90, Rear Eye	40-41
Model 94, Spherical Rear Eye.....	42-44
Double Rod End.....	45
Large Bore Cylinder Dimensions (10"-20" Bores)	46-57
Models 50 & D50, No Mounting.....	46-47
Models 63 & 64, Square Head or Cap	48-49
Models 72 & 73, Side Lug or Centerline Lug.....	50-51
Models 81 & 82, Trunnion Head End or Cap End	52-53
Model 89, Intermediate Trunnion	54-55
Models 84 & 90, Fixed Clevis or Rear Eye.....	56-57
Rod End Styles and Dimensions	58
Rod End Couplers	59
Rod End Accessories.....	60-62
Cylinder Stroke Adjustment & Other Modifications.....	63
Proximity Switches.....	64-67
Determining Proper Bore Size.....	68
Operating Fluids and Temperature Range	69
Position Sensing Cylinders	70-74
Cylinder Pressure Ratings / Oversize Ports.....	75
Determining Stop Tube Requirements.....	76-77
Determining Column Strength of Piston Rod.....	78
Non-Sag Piston Rods.....	79
Keying and Pinning of Cylinders	80
Cylinder Parts List and Seal Kits	81
Cylinder Storage, Installation, Mounting Recommendations, Trouble Shooting.....	82-83
Selection Guide / How To Order.....	84-85
Offer of Sale.....	86
Safety Guidelines	87

Miller H Series Hydraulic Cylinders

Standard Design Features to Maximize Performance and Uptime

Cushion

Unique, optional, self-regulating cushion automatically adjusts to pressure, load and speed variations. This reduces shock and cushioning time, which permits quick out-of-cushion starts, thus increasing machine cycle rates.

Piston Seals

Rugged PTFE U-cup seals are mechanically locked to prevent rolling or blowout. Temperatures to 200°F standard. To 450° when spring-loaded.

Piston

One-piece piloted piston provides maximum strength. Piston threads increase in size for added strength when oversize rods are required.

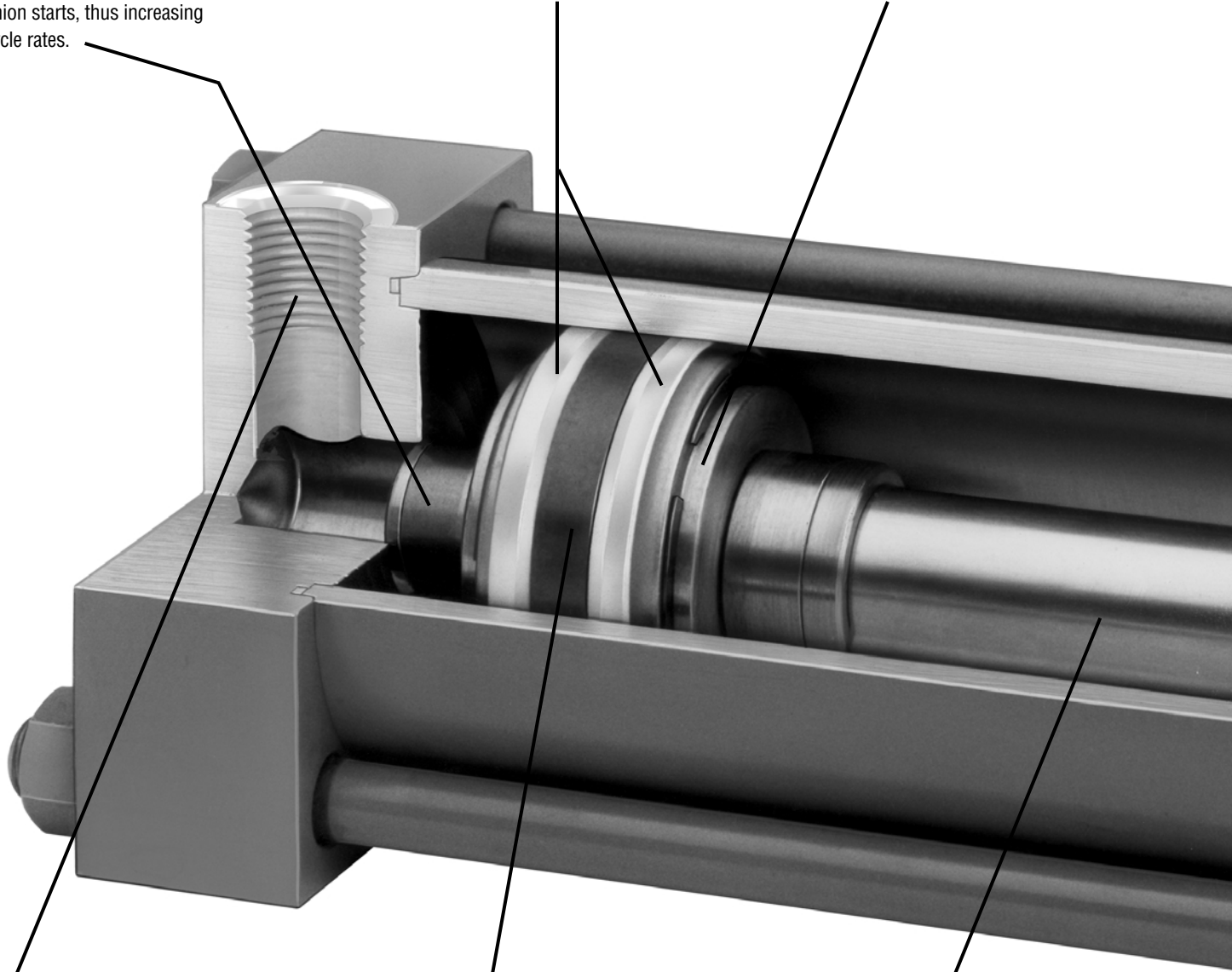

Ports

SAE "O" ring ports are standard. NPTF ports are optional.

Piston Wear Band

Durable, non-metallic (1½" - 6" Bores) (bronze 7" -20" bores) piston wear band reduces possibility of damaging piston which can score expensive tubing. Reduces need for piston replacement.

Piston Rod

Case-hardened to 54 Rockwell C and chrome-plated rod resists mechanical damage and side loads.

Miller H Series Hydraulic Cylinders

Standard Design Features to Maximize Performance and Uptime

Tube End Seal

PTFE "SHEF" tube-end seal resists heat, extrusion, shearing, and hydraulic fluids. Patented strip-type seal repairs all bore sizes with minimum inventory and downtime.

Rod Seal

Durable urethane rod seal is pressure-energized and wear-compensating for long, leak-free service.

Bushing

Nodular iron bushing provides longer bearing life than conventional bronze bushings. Protects against side loads. Removes easily using a common Allen wrench. Cylinder tie rods not disturbed.

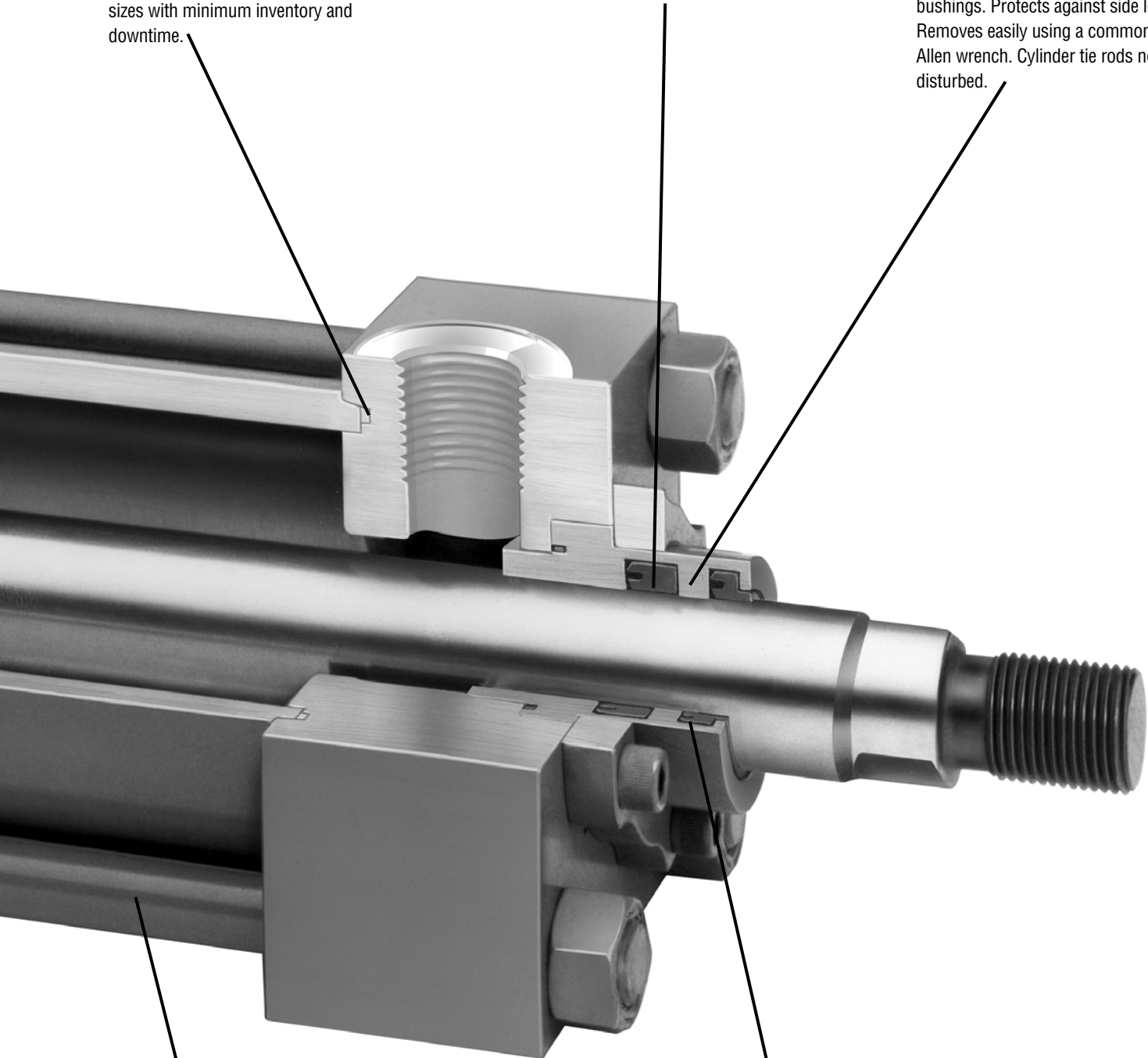

Tie Rods

High strength, 100,000 to 125,000 PSI minimum yield material. Provides protection against shock pressures.

Wiper Seal

Wipes away dirt that may have accumulated on piston rod and prevents it from oversizing bushing. Also provides secondary rod seal.

Mounting Styles That Fit Your Installation Requirement

Miller H Series hydraulic cylinders operate at internal pressures up to 3000 PSI, and incorporate proven Miller design characteristics to provide safe, reliable power for many heavy-duty industrial applications. Available in 23 standard mounting configurations to provide centerline, foot or pivot installations as explained below.

Centerline Mounting

The preferred cylinder installation method, centerline mounting places the mounting bolts in simple tension so that the mounting mechanism is protected from compound forces. Centerline mounting is a rigid mounting style and thus requires accurate cylinder alignment to prevent damage to cylinder working parts.

Miller Series H mounting configurations that provide centerline support are tie-rod mounts (51, 52, 53), flange mounts with square or rectangular flanges fastened to the cylinder head or cap (61, 62, 65, 66), rectangular head and cap cylinders (67 and 68), and centerline lug cylinders (73).

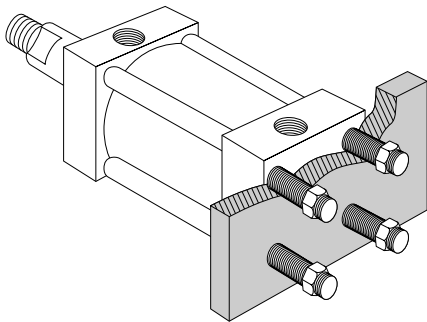

Centerline mounting is preferable since it prevents compound forces from acting on the mounting bolts (tie rod model shown).

Foot Mounting

Foot mounting allows the cylinder to be mounted and secured along its side, on both the head and cap end. When considering this style of mount, it should be noted that the mounting surface plane is not truly centered with the line of force plane. Therefore, the mounting bolts may be subjected to a significant amount of shear stress. Foot mounts are rigid in nature. Accurate cylinder alignment must be practiced when selecting this type of mount.

Lugs, either welded onto the sides of the head and cap (72) or attached to the ends of the cylinder (77), are the usual form of foot mounts. Centerline lugs are available as Model H 73. As an alternative to the use of lugs, flush mounting incorporates tapped mounting holes on the sides of the cylinder head and cap (74).

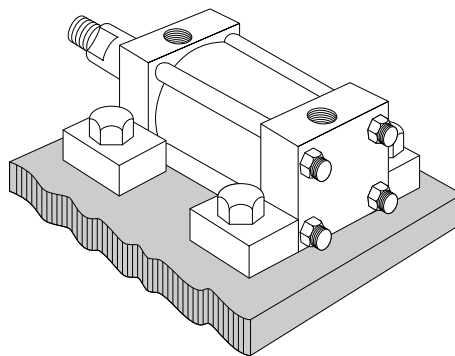

Foot mounting secures the cylinder on its side, but can subject the mounting bolts to compound stress (cylinder side lugs shown).

Pivot Mounting

Pivot mounting is used when the cylinder must pivot during piston motion. Clevis and trunnion mounts are the two methods used to allow this motion.

The clevis end and rear eye design locates the pivot point at the cap end of the cylinder (84, 86, 90, 94). Trunnion mounting uses trunnions on the head, cap or side of the cylinder to allow it to pivot at any of three locations (81, 82, 89). Both clevis and trunnion mounting configurations allow the cylinder to pivot in one plane only.

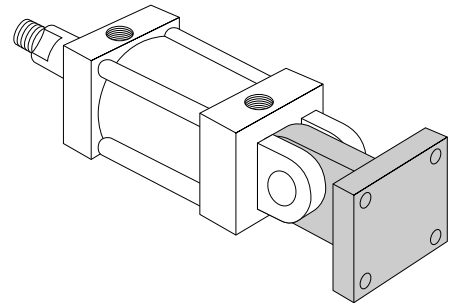

Pivot mounting allows the cylinder to pivot during piston motion (clevis method shown).

Miller H Series Hydraulic Cylinders

Index
23 Mounting Styles Available

Centerline Mounts

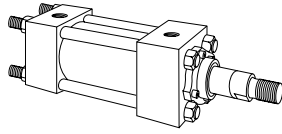

Tie Rod Models 50*, 51, (NFPA MX1), 52 (NFPA MX2) 53 (NFPA MX3), 54 (NFPA MX4)

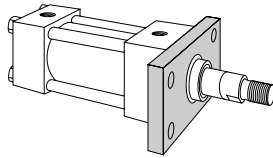

Rectangular Flange/Head End Model 61 (NFPA MF1)

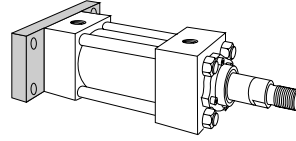

Rectangular Flange/Cap End Model 62 (NFPA MF2)

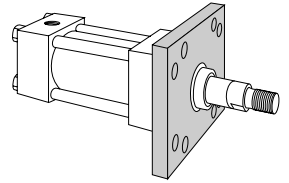

Square Flange/Head End Model 65 (NFPA MF5)

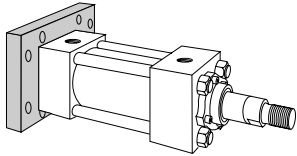

Square Flange/Cap End Model 66 (NFPA MF6)

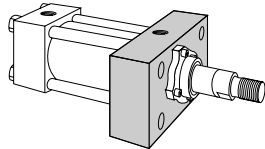

Rectangular Head Model 67 (NFPA ME5)
10" - 20" Bore Square Head Model 63

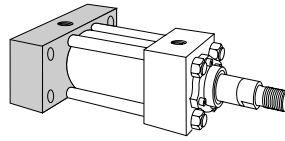

Rectangular Cap Model 68 (NFPA ME6)
10" - 20" Bore Square Cap Model 64

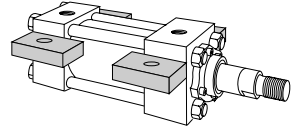

Centerline Lug Model 73 (NFPA MS3)

Foot Mounts

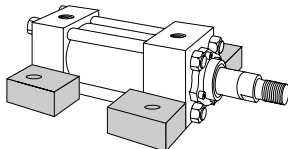

Side Lug Model 72 (NFPA MS2)

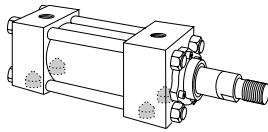

Side Tapped Model 74 (NFPA MS4)

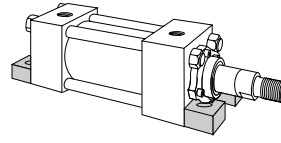

End Lug Model 77 (NFPA MS7)

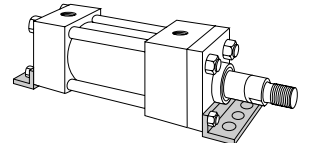

End Angle Model 71 (NFPA MS1)

Pivot Mounts

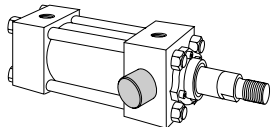

Trunnion/Head End Model 81 (NFPA MT1)

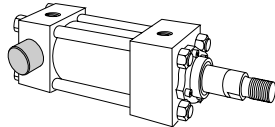

Trunnion/Cap End Model 82 (NFPA MT2)

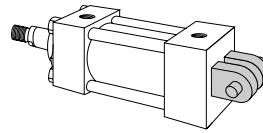

Fixed Clevis Model 84 (NFPA MP1)

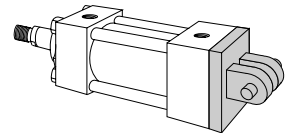

Detachable Clevis Model 86 (NFPA MP2)

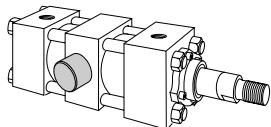

Intermediate Trunnion Model 89 (NFPA MT4)

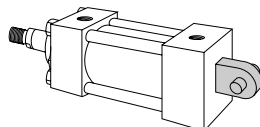

Rear Eye Model 90 (NFPA MP3)

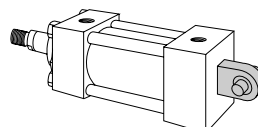

Spherical Eye Model 94

* Model 50 - No tie rod extension
Model 51 - Tie rods extended head and cap
Model 52 - Tie rods extended cap end only
Model 53 - Tie rods extended head end only
Model 54 - Tie rods (2) extended head and cap at position No. 3

Miller H Series Hydraulic Cylinders

1½" thru 20" Bore Cylinders

Bushing Retainer Style

While the standard Miller cylinder design utilizes a bolted bushing, on certain combinations of bore size, rod size and/or mounting style a bolted bushing would interfere with the tie rod nuts. In those cases, a square retainer-held bushing is used.

The selection chart below lists all the possible combinations, with a ● indicating bolted type bushing and a ■ indicating use of the full square retainer method.

Please note that dimensional information is provided on the appropriate catalog pages for the two different styles.

MOUNT CONFIGURE MODEL NO.	1½" BORE		2" BORE		2½" BORE		3¼" BORE		4" BORE			5" BORE			6" BORE		7" BORE		8" BORE								
	STD ROD	OS ROD	STD ROD	OS ROD	STD ROD	OS ROD	STD ROD	OS ROD	STD ROD	OS ROD	STD ROD	OS ROD	STD ROD	OS ROD	STD ROD	OS ROD	STD ROD	OS ROD	STD ROD	OS ROD							
	5/8	1 **	1	1 3/8 **	1	1 3/8	1 3/4 **	1 3/8	1 3/4	2	1 3/4	2	2 1/2	2	2 1/2	3	3 1/2	2 1/2	3, 3 1/2	4	3	3 1/2, 4 4 1/2	5	3 1/2	4	4 1/2, 5 5 1/2	
50, 52	●	■	●	■	●	●	●	●	●	●	●	●	●	●	●	●	●	●	●	●	●	●	●	●	●	●	●
51	■	■	■	■	●	●	●	●	●	●	●	●	●	●	●	●	●	●	●	●	●	●	●	●	●	●	●
53	■	■	■	■	●	●	●	●	●	●	●	●	●	●	●	●	●	●	●	●	●	●	●	●	●	●	●
54	■	■	■	■	●	●	●	●	●	●	●	●	●	●	●	●	●	●	●	●	●	●	●	●	●	●	●
61	■	■	■	■	●	■	■	●	●	■	●	●	●	●	●	●	●	●	●	●	●	●	●	●	●	●	●
62	●	■	●	■	●	●	●	●	●	●	●	●	●	●	●	●	●	●	●	●	●	●	●	●	●	●	●
65	■	■	■	■	●	■	■	●	●	■	●	●	●	●	●	●	●	●	●	●	●	●	●	●	●	●	●
66	●	■	●	■	●	●	●	●	●	●	●	●	●	●	●	●	●	●	●	●	●	●	●	●	●	●	●
67	●	●	●	●	●	●	●	●	●	●	●	●	●	●	●	●	●	●	●	●	●	●	●	●	●	●	●
68	●	■	●	■	●	●	●	●	●	●	●	●	●	●	●	●	●	●	●	●	●	●	●	●	●	●	●
71	■	■	■	■	■	■	■	■	■	■	■	■	■	■	■	■	■	■	■	■	N/A	N/A	N/A	N/A	N/A	N/A	N/A
72	●	■	●	■	●	●	●	●	●	●	●	●	●	●	●	●	●	●	●	●	●	●	●	●	●	●	●
73	●	■	●	■	●	●	●	●	●	●	●	●	●	●	●	●	●	●	●	●	●	●	●	●	●	●	●
74	●	■	●	■	●	●	●	●	●	●	●	●	●	●	●	●	●	●	●	●	‡	‡	●	●	‡	●	‡
77	●*	■+	●*+	■+	●	●*	■+	●	●	■+	●	●	■	●	●	■	●	●	■	●	●	N/A	●	●	●	●	
81	●	■	●	■	●	●	●	●	●	●	●	●	●	●	●	●	●	●	●	●	●	●	●	●	●	●	●
82	●	■	●	■	●	●	●	●	●	●	●	●	●	●	●	●	●	●	●	●	●	●	●	●	●	●	●
84	●	■	●	■	●	●	●	●	●	●	●	●	●	●	●	●	●	●	●	●	●	●	●	●	●	●	●
86	●	■	●	■	●	●	●	●	●	●	●	●	●	●	●	●	N/A	N/A	N/A	N/A	N/A	N/A	N/A	N/A	N/A	N/A	N/A
89	●	■	●	■	●	●	●	●	●	●	●	●	●	●	●	●	●	●	●	●	●	●	●	●	●	●	●
90	●	■	●	■	●	●	●	●	●	●	●	●	●	●	●	●	●	●	●	●	●	●	●	●	●	●	●
94	●	■	●	■	●	●	●	●	●	●	●	●	●	●	●	●	●	●	●	●	N/A	N/A	N/A	N/A	N/A	N/A	N/A

Mounting Configuration (Model No.)	BORE/ROD SIZE AVAILABILITY											
	10" Bore		12" Bore		14" Bore		16" Bore		18" Bore		20" Bore	
	STD. ROD	OVERSIZED RODS	STD. ROD	OVERSIZED RODS	STD. ROD	OVERSIZED RODS	STD. ROD	OVERSIZED ROD	STD. ROD	OVERSIZED RODS	STD. ROD	
	4½	5, 5½, 7	5½	7, 8	7	8, 9, 10	8	9, 10	9	10	10	
63, 64, 84, 90	●	●	●	●	●	●	●	●	●	●	●	
81, 82, 72, 73	●	●	●	●	●	●	N/A	N/A	N/A	N/A	N/A	
89	●	●	●	●	N/A	N/A	N/A	N/A	N/A	N/A	N/A	

- Bolted type bushing construction
- Full Square retainer construction
- * Mounting lugs at head end must be removed before bushing
- ** Cylinders furnished with metallic sealing rings and wear band in place of "U" cup seals.
- N/A Not Available

- + If rod eye is used on Style 2 rod end, it will interfere with Model 77 mounting lugs.
- ‡ Reduced pressure ratings due to shallow tapped mounting holes.

Miller H Series Hydraulic Cylinders

1½" thru 20" Bore Cylinders Port Size Reference Chart

1½" thru 8" Bore Size Reference Chart SAE Ports Standard — NPTF Ports Optional

Cylinder Bore Diam. (inches)	Standard SAE Port		Optional NPTF Port		4 Bolt SAE (Code 61)	
	NFPA Standard	First Oversize		Standard		** Maximum Oversize
		Head	Cap			
1½	(-8)	(-10)	(-10)	½ - 14	¾ - 14	N/A
2	(-8)	(-10)	(-10)	½ - 14	¾ - 14	N/A
2½	(-8)	**(-10)	(-10)	½ - 14	¾ - 14	½
3¼	(-12)	**(-14)	(-14)	¾ - 14	1 - 11½	¾
4	(-12)	**(-14)	(-14)	¾ - 14	1 - 11½	¾
5	(-12)	**(-16)	**(-16)	¾ - 14	1 - 11½	¾
6	(-16)	**(-20)	**(-20)	1 - 11½	1¼-11½	1
7	(-20)	**(-24)	**(-24)	1¼ - 11½	1½-11½	1¼
8	(-24)	**(-32)	**(-32)	1½ - 11½	2 - 11½	1½
10	(-32)	**(-32)	**(-32)	2-11½	◆	2
12	(-32)	**(-32)	**(-32)	2½-8	◆	2½ (2500 psi)
14	(-32)	**(-32)	**(-32)	3-8	◆	3 (2000 psi)
16	(-32)	**(-32)	**(-32)	3½-8	◆	—
18	(-32)	**(-32)	**(-32)	4-8	◆	—
20	(-32)	**(-32)	**(-32)	5-8	◆	—

1½" thru 20" Bore Port Size Reference Chart

DASH Number	Tube O.D. (in.)	Thread Size (in.)
(8)	.50	.75 - 16
(10)	.62	.88 - 14
(12)	.75	1.06 - 12
(14)	.88	1.18 - 12
(16)	1	1.31 - 12
(20)	1.25	1.62 - 12
(24)	1.50	1.88 - 12
(32)	2	2.50 - 12

Miller SAE O-Ring ports conform to SAE standard J514 (straight thread O-Ring boss).

Note: ISO 6149 ports are available as an option and should be identified as a cylinder modification in the cylinder number.

** Welded ◆ Consult Miller Engineering
Note: All Optional Maximum Oversize NPTF Ports are Welded.

Miller H Series Hydraulic Cylinders

Tie Rods Extended 1½"–8" Bore Cylinders

Model 52-B (NFPA MX2) Bolted Bushing Tie Rods Extended Cap End

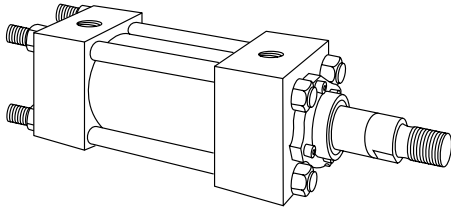

Also Available

Model 50-B No Tie Rods Extended, Model 51-B (NFPA MX1) Tie Rods Extended both ends, Model 53-B (NFPA MX3) Tie Rods Extended head end, Model 54-B (NFPA MX4) two Tie Rods Extended both ends at position #3. All of the above models can be dimensioned from Model 52-B shown.

Mounting Dimensions (see tables on opposite page)

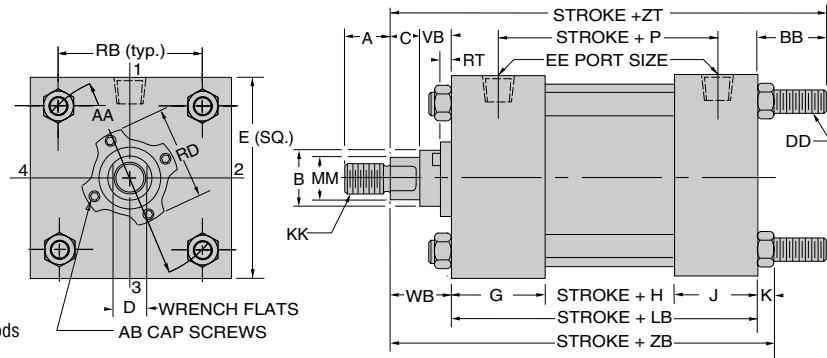

Model 52-R (NFPA MX2) Square Retainer Held Bushing Tie Rods Extended Cap End

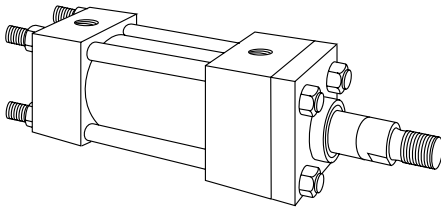

Also Available

Model 50-R No Tie Rods Extended, Model 51-R (NFPA MX1) Tie Rods Extended both ends, Model 53-R (NFPA MX3) Tie Rods Extended head end, Model 54-R (NFPA MX4) two Tie Rods Extended both ends at position #3. All of the above models can be dimensioned from Model 52-R shown.

Mounting Dimensions (see tables on opposite page)

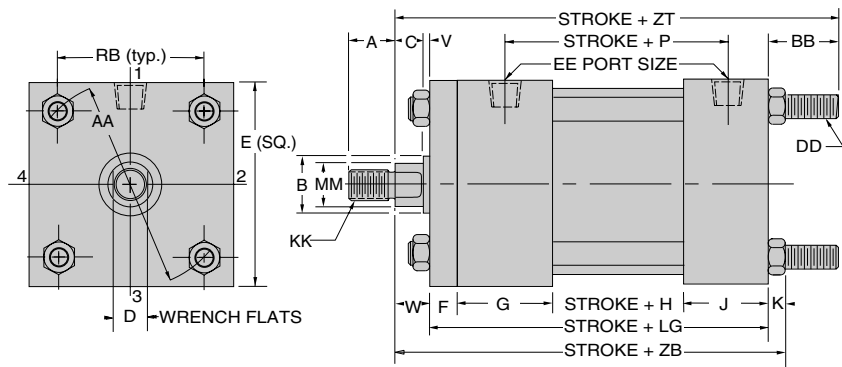

Common Rod End Styles & Dimensions

For additional standard rod ends, see "Rod End Styles and Dimensions" page.

Style No. 2-Standard Threaded on Turndown Section

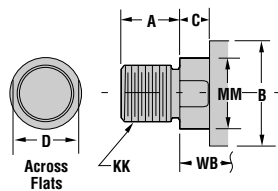

Style No. 4 Short Rod End-Internal Threads

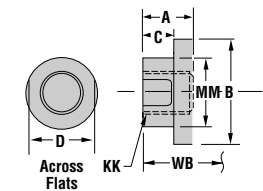

Style No. 5 Threaded Intermediate Male

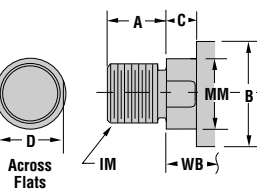

Style No. 6 Studded Rod End (Available Thru 2" Rod Diameter)

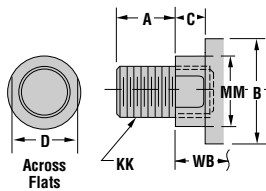

"Special" Thread Style X

Special thread, extension, rod eye, blank, etc., are also available.

To order, specify "Style X" and give desired dimensions for KK, A, WB or W. If otherwise special, furnish dimensioned sketch.

Miller H Series Hydraulic Cylinders

Rectangular Flange/Head End 1 1/2" - 8" Bore Cylinders

Model 61-B (NFPA MF1) Bolted Bushing Rectangular Flange/Head End

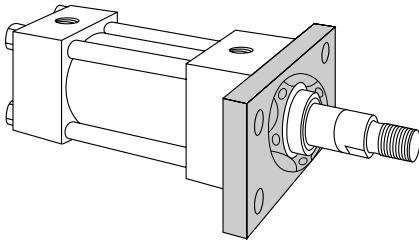

Note: High tensile mounting bolts should be used. Hardened flat washers should be used on 2 1/2" through 8" bore cylinders.

Mounting Dimensions (see tables on opposite page)

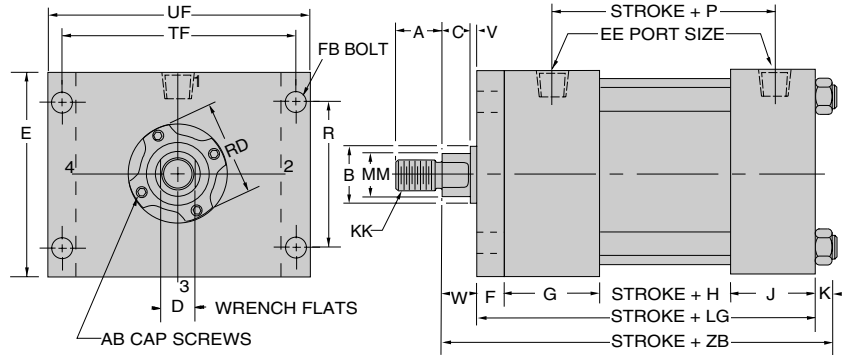

Model 61-R (NFPA MF1) Retainer Held Bushing Rectangular Flange/Head End (1 1/2" - 6" Bores)

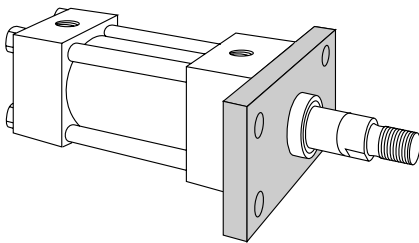

Note: High tensile mounting bolts should be used. Hardened flat washers should be used on 2 1/2" through 6" bore cylinders.

Mounting Dimensions (see tables on opposite page)

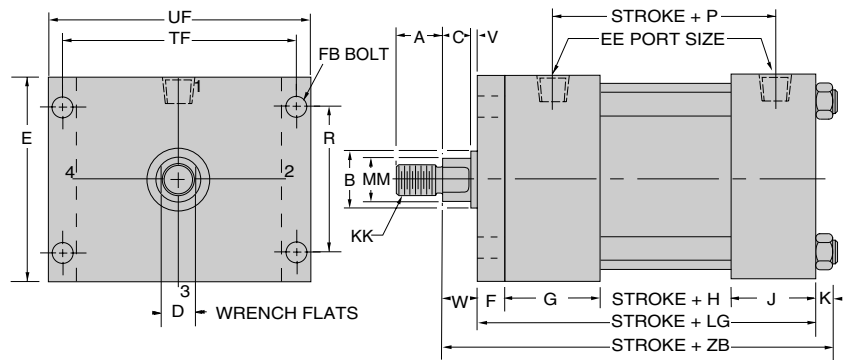

Note: To achieve higher pressure ratings in some size combinations retainer construction can be furnished in lieu of standard bolted bushing construction. -See pressure limitation chart for retainer held bushings on opposite page.

Common Rod End Styles & Dimensions

For additional standard rod ends, see "Rod End Styles and Dimensions" page.

Style No. 2-Standard Threaded on Turndown Section

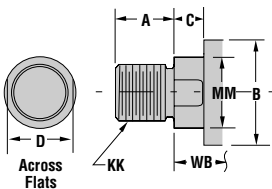

Style No. 4 Short Rod End-Internal Threads

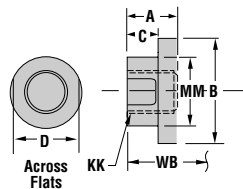

Style No. 5 Threaded Intermediate Male

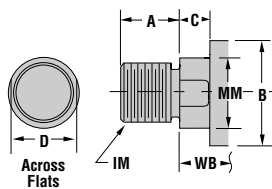

Style No. 6 Studded Rod End (Available Thru 2" Rod Diameter)

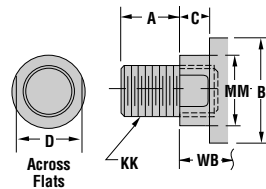

"Special" Thread Style X

Special thread, extension, rod eye, blank, etc., are also available.

To order, specify "Style X" and give desired dimensions for KK, A, WB or W. If otherwise special, furnish dimensioned sketch.

Miller H Series Hydraulic Cylinders

Rectangular Flange/Cap End 1½"–8" Bore Cylinders

Model 62-B (NFPA MF2) Bolted Bushing Rectangular Flange/Cap End

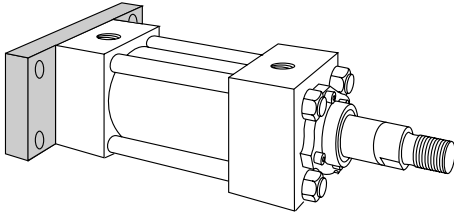

Mounting Dimensions (see tables on opposite page)

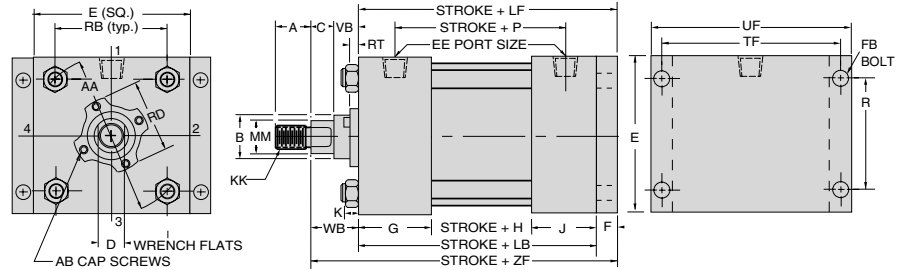

Note: High tensile mounting bolts should be used. Hardened flat washers should be used on 2½" through 8" bore cylinders.

Model 62-R (NFPA MF2) Square Retainer Held Bushing Rectangular Flange/Cap End (1½" - 6" Bore)

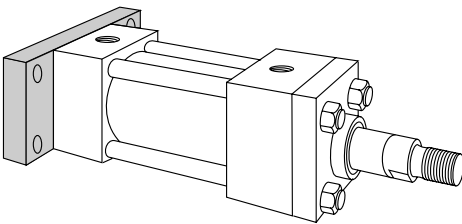

Mounting Dimensions (see tables on opposite page)

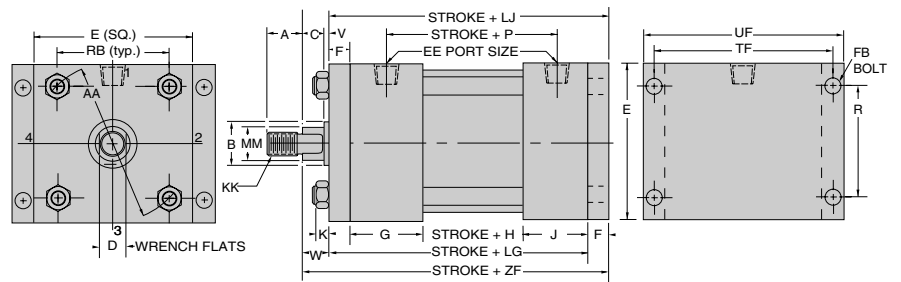

Note: High tensile mounting bolts should be used. Hardened flat washers should be used on 2½" through 6" bore cylinders.

Common Rod End Styles & Dimensions

For additional standard rod ends, see "Rod End Styles and Dimensions" page.

Style No. 2-Standard Threaded on Turndown Section

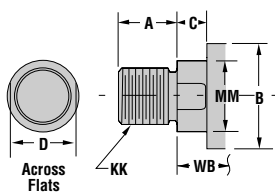

Style No. 4 Short Rod End-Internal Threads

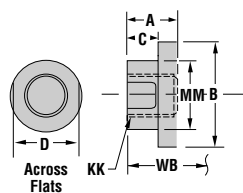

Style No. 5 Threaded Intermediate Male

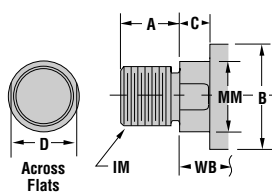

Style No. 6 Studded Rod End (Available Thru 2" Rod Diameter)

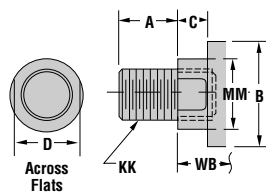

"Special" Thread Style X

Special thread, extension, rod eye, blank, etc., are also available.

To order, specify "Style X" and give desired dimensions for KK, A, WB or W. If otherwise special, furnish dimensioned sketch.

Pressure Limitations For Models 62-B and 62-R

Bore	1½	2	2½	3¼	4	5	6	7	8
Pressure (PSI)	1490	2170	2140	1850	1940	1400	1270	740	620

For higher rated cap end mounted cylinders, see Model H-68.

Miller H Series Hydraulic Cylinders

Rectangular Flange/Cap End 1½"– 8" Bore Cylinders

Cylinder Body Dimensions

Bore Size	E	F	G	J	K	R	AA	*EE		FB	RB	TF	UF
								SAE	NPTF				
1½	2½	¾	1¾	1½	¾	1.63	2.3	-8	½	¾	1.63	3 ⁷ / ₁₆	4¼
2	3	5⁄8	1¾	1½	7⁄16	2.05	2.9	-8	½	½	2.05	4¼	5¼
2½	3½	5⁄8	1¾	1½	7⁄16	2.55	3.6	-8	½	½	2.55	4 ⁹ / ₈	5 ⁵ / ₈
3¼	4½	¾	2	1¾	9⁄16	3.25	4.6	-12	¾	5⁄8	3.25	5 ⁷ / ₈	7¼
4	5	7⁄8	2	1¾	9⁄16	3.82	5.4	-12	¾	5⁄8	3.82	6 ³ / ₈	7 ⁵ / ₈
5	6½	7⁄8	2	1¾	1 ³ / ₁₆	4.95	7.0	-12	¾	7⁄8	4.95	8 ³ / ₁₆	9¾
6	7½	1	2¼	2¼	1 ⁵ / ₁₆	5.73	8.1	-16	1	1	5.73	9 ⁷ / ₁₆	11¼
7	8½	1	2¾	2¾	1	6.58	9.3	-20	1¼	1 ¹ / ₈	6.58	10 ⁵ / ₈	12 ⁵ / ₈
8	9½	1	3	3	1¼	7.50	10.6	-24	1½	1¼	7.50	11 ¹³ / ₁₆	14

* SAE ports are standard, NPTF ports are available at no extra charge.
Note: Mounting holes are 1⁄16" larger than bolt sizes (FB) shown.

Add Stroke

H	LB	±LD	LF	LG	LJ	P
1 ³ / ₈	4 ⁵ / ₈	4 ⁷ / ₈	5	5	5 ⁵ / ₈	2 ⁷ / ₈
1 ³ / ₈	4 ⁵ / ₈	4 ⁷ / ₈	5¼	5¼	5 ⁵ / ₈	2 ⁷ / ₈
1½	4¾	5	5 ³ / ₈	5 ³ / ₈	6	3
1¾	5½	5¾	6¼	6¼	7	3½
2	5¾	6	6 ⁵ / ₈	6 ⁵ / ₈	7½	3¾
2½	6¼	6½	7¼	7¼	8	4¼
2 ⁷ / ₈	7 ³ / ₈	7 ³ / ₈	8 ³ / ₈	8 ³ / ₈	9 ³ / ₈	4 ⁷ / ₈
3	8½	8½	9½	—	—	5 ³ / ₈
3½	9½	9½	10½	—	—	6 ¹ / ₈

Rod End Dimensions

Bore Size	Rod Dia (MM)	A	B -.001 to -.003	C	D	V	W	AB	IM Style 5	KK Styles 2,4&6	RD (Max.)	RT	VB	WB
1½	5⁄8	¾	1.125	¾	½	¼	5⁄8	10-32	1⁄2-20	7⁄16-20	1.972	.316	5⁄8	1
	1	1 ¹ / ₈	1.500	½	7⁄8	½	1	—	7⁄8-14	¾-16	—	—	—	—
2	1	1 ¹ / ₈	1.500	½	7⁄8	¼	¾	¼-28	7⁄8-14	¾-16	2.472	.328	7⁄8	1 ³ / ₈
	1 ³ / ₈	1 ⁵ / ₈	2.000	5⁄8	1 ¹ / ₈	¾	1	—	1¼-12	1-14	—	—	—	—
2½	1	1 ¹ / ₈	1.500	½	7⁄8	¼	¾	¼-28	7⁄8-14	¾-16	2.472	.328	7⁄8	1 ³ / ₈
	1 ³ / ₈	1 ⁵ / ₈	2.000	5⁄8	1 ¹ / ₈	¾	1	¼-28	1¼-12	1-14	2.972	.328	1	1 ⁵ / ₈
3¼	1¾	2	2.375	¾	1½	½	1¼	¼-28	1½-12	1¼-12	3.470	.313	1 ¹ / ₈	1 ⁷ / ₈
	1 ³ / ₈	1 ⁵ / ₈	2.000	5⁄8	1 ¹ / ₈	¼	7⁄8	¼-28	1¼-12	1-14	2.972	.328	1	1 ⁵ / ₈
4	1¾	2	2.375	¾	1½	½	1¼	¼-28	1½-12	1¼-12	3.470	.313	1 ¹ / ₈	1 ⁷ / ₈
	2	2¼	2.625	7⁄8	1 ¹¹ / ₁₆	¾	1¼	¼-28	1¾-12	1½-12	3.720	.313	1 ¹ / ₈	2
5	2	2¼	2.625	7⁄8	1 ¹¹ / ₁₆	¼	1 ¹ / ₈	¼-28	1¾-12	1½-12	3.720	.313	1 ¹ / ₈	2
	2½	3	3.125	1	2¼	¾	1 ³ / ₈	¼-28	2¼-12	1 ⁷ / ₈ -12	4.252	.313	1¼	2¼
6	2½	3	3.125	1	2¼	¾	1 ³ / ₈	¼-28	2¾-12	2¼-12	4.752	.313	1¼	2¼
	3½	3½	4.250	1	3	¾	1 ³ / ₈	¼-28	3¼-12	2½-12	5.252	.313	1¼	2¼
7	2½	3	3.125	1	2¼	¾	1¼	¼-28	2¾-12	1 ⁷ / ₈ -12	4.252	.313	1¼	2¼
	3	3½	3.750	1	2 ⁵ / ₈	¼	1¼	¼-28	2¾-12	2¼-12	4.752	.313	1¼	2¼
8	3½	3½	4.250	1	3	¼	1¼	¼-28	3¼-12	2½-12	5.252	.313	1¼	2¼
	4	4	4.750	1	3 ³ / ₈	¼	1¼	5⁄16-24	3¾-12	3-12	5.939	.610	1¼	2¼
9	3	3½	3.750	1	2 ⁵ / ₈	—	—	¼-28	2¾-12	2¼-12	4.752	.313	1¼	2¼
	3½	3½	4.250	1	3	—	—	¼-28	3¼-12	2½-12	5.252	.313	1¼	2¼
10	4	4	4.750	1	3 ³ / ₈	—	—	5⁄16-24	3¾-12	3-12	5.939	.610	1¼	2¼
	4½	4½	5.250	1	3 ⁷ / ₈	—	—	5⁄16-24	4¼-12	3¼-12	6.439	.610	1¼	2¼
11	5	5	5.750	1	4¼	—	—	5⁄16-24	4¾-12	3½-12	6.939	.610	1¼	2¼
	5½	5½	6.250	1	4 ⁵ / ₈	—	—	5⁄16-24	5¼-12	4-12	7.439	.610	1¼	2¼

Add Stroke

ZF
6
6 ³ / ₈
6 ⁵ / ₈
6 ⁷ / ₈
6¾
7
7¼
7 ⁷ / ₈
8¼
8½
8 ⁵ / ₈
8 ⁷ / ₈
9 ¹ / ₈
9 ³ / ₈
9 ⁵ / ₈
10 ⁵ / ₈
10 ⁵ / ₈
10 ⁵ / ₈
10 ⁵ / ₈
11¾
11¾
11¾
11¾
11¾
12¾
12¾
12¾
12¾
12¾

Miller H Series Hydraulic Cylinders

Square Flange/Head End 1½"–8" Bore Cylinders

Model 65-B (NFPA MF5) Bolted Bushing Square Flange/Head End

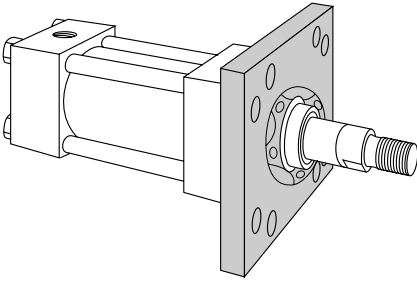

Note: High tensile mounting bolts should be used. Hardened flat washers should be used on 2½" through 8" bore cylinders.

Mounting Dimensions (See tables on opposite page)

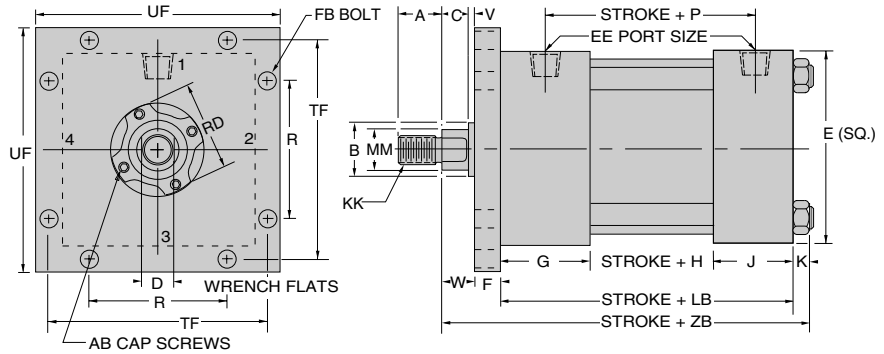

Model 65-R (NFPA MF5) Retainer Held Bushing Square Flange/Head End

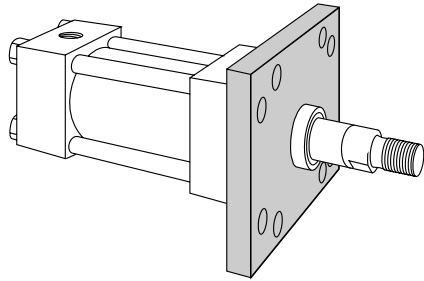

Note: High tensile mounting bolts should be used. Hardened flat washers should be used on 2½" through 8" bore cylinders.

Mounting Dimensions (See tables on opposite page)

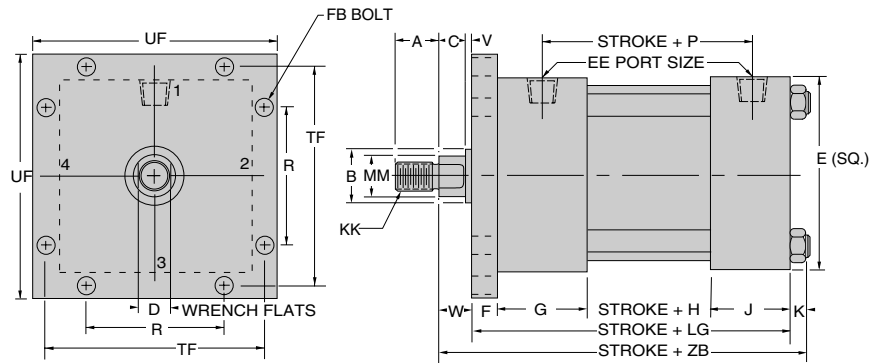

Common Rod End Styles & Dimensions

For additional standard rod ends, see "Rod End Styles and Dimensions" page.

Style No. 2-Standard Threaded on Turndown Section

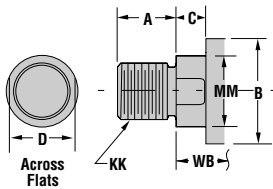

Style No. 4 Short Rod End-Internal Threads

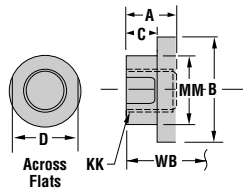

Style No. 5 Threaded Intermediate Male

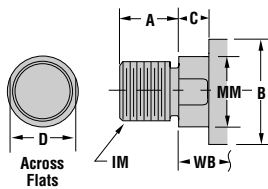

Style No. 6 Studded Rod End (Available Thru 2" Rod Diameter)

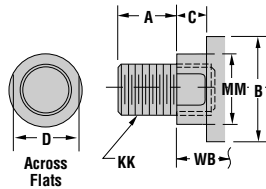

"Special" Thread Style X
Special thread, extension, rod eye, blank, etc., are also available.
To order, specify "Style X" and give desired dimensions for KK, A, WB or W. If otherwise special, furnish dimensioned sketch.

Miller H Series Hydraulic Cylinders

Square Flange/Head End 1½"–8" Bore Cylinders

Cylinder Body Dimensions

Bore Size	E	F	G	J	K	R	*EE		FB	TF	UF
							SAE	NPTF			
1½	2½	¾	1¾	1½	¾	1.63	-8	½	¾	37/16	4¼
2	3	5/8	1¾	1½	7/16	2.05	-8	½	½	4½	5½
2½	3½	5/8	1¾	1½	7/16	2.55	-8	½	½	45/8	55/8
3¼	4½	¾	2	1¾	9/16	3.25	-12	¾	5/8	57/8	7½
4	5	7/8	2	1¾	9/16	3.82	-12	¾	5/8	63/8	75/8
5	6½	7/8	2	1¾	13/16	4.95	-12	¾	7/8	83/16	9¾
6	7½	1	2¼	2¼	15/16	5.73	-16	1	1	97/16	11¼
7	8½	1	2¾	2¾	1	6.58	-20	1¼	1½	105/8	125/8
8	9½	1	3	3	1¼	7.50	-24	1½	1¼	1113/16	14

* SAE ports are standard, NPTF ports are available at no extra charge.
 † LD dimension is for double rod end models. See Double Rod End page.
 Note: Mounting holes are 1/16" larger than bolt sizes (FB) shown.

Add Stroke

H	LB	‡LD	LG	P
1¾	45/8	47/8	5	27/8
1¾	45/8	47/8	5¼	27/8
1½	4¾	5	53/8	3
1¾	5½	5¾	6¼	3½
2	5¾	6	65/8	3¾
2½	6¼	6½	7½	4¼
27/8	73/8	75/8	83/8	47/8
3	8½	8½	9½	53/8
3½	9½	9½	10½	6½

Rod End Dimensions

Bore Size	Rod Dia (MM)	A	B -.001 to -.003	C	D	V	W	AB	IM Style 5	KK Styles 2,4&6	RD (Max.)	ZB
1½	1	11/8	1.500	½	7/8	½	1	—	7/8-14	¾-16	—	63/8
	1	11/8	1.500	½	7/8	¼	¾	—	7/8-14	¾-16	—	67/16
2	13/8	15/8	2.000	5/8	1½	¾	1	—	1¼-12	1-14	—	611/16
	1	11/8	1.500	½	7/8	¼	¾	¼-28	7/8-14	¾-16	2.472	69/16
2½	13/8	15/8	2.000	5/8	1½	¾	1	—	1¼-12	1-14	—	613/16
	1¾	2	2.375	¾	1½	½	1¼	—	1½-12	1¼-12	—	71/16
3¼	13/8	15/8	2.000	5/8	1½	¼	7/8	¼-28	1¼-12	1-14	2.972	711/16
	1¾	2	2.375	¾	1½	¾	1½	¼-28	1½-12	1¼-12	3.470	715/16
4	2	2¼	2.625	7/8	11/16	¾	1¼	—	1¾-12	1½-12	—	81/16
	1¾	2	2.375	¾	1½	¼	1	¼-28	1½-12	1¼-12	3.470	83/16
4	2	2¼	2.625	7/8	11/16	¼	1½	¼-28	1¾-12	1½-12	3.720	85/16
	2½	3	3.125	1	21/16	¾	13/8	¼-28	2¼-12	17/8-12	4.252	89/16
5	2	2¼	2.625	7/8	11/16	¼	1½	¼-28	1¾-12	1½-12	3.720	91/16
	2½	3	3.125	1	21/16	¾	13/8	¼-28	2¼-12	17/8-12	4.252	95/16
5	3	3½	3.750	1	25/8	¾	13/8	¼-28	2¾-12	2¼-12	4.752	95/16
	3½	3½	4.250	1	3	¾	13/8	¼-28	3¼-12	2½-12	5.252	95/16
6	2½	3	3.125	1	21/16	¼	1¼	¼-28	2¼-12	17/8-12	4.252	109/16
	3	3½	3.750	1	25/8	¼	1¼	¼-28	2¾-12	2¼-12	4.752	109/16
6	3½	3½	4.250	1	3	¼	1¼	¼-28	3¼-12	2½-12	5.252	109/16
	4	4	4.750	1	33/8	¼	1¼	5/16-24	3¾-12	3-12	5.939	109/16
7	3	3½	3.750	1	25/8	¼	1¼	¼-28	2¾-12	2¼-12	4.752	11¾
	3½	3½	4.250	1	3	¼	1¼	¼-28	3¼-12	2½-12	5.252	11¾
7	4	4	4.750	1	33/8	¼	1¼	5/16-24	3¾-12	3-12	5.939	11¾
	4½	4½	5.250	1	37/8	¼	1¼	5/16-24	4¼-12	3¼-12	6.439	11¾
7	5	5	5.750	1	4¼	¼	1¼	5/16-24	4¾-12	3½-12	6.939	11¾
	3½	3½	4.250	1	3	¼	1¼	¼-28	3¼-12	2½-12	5.252	13
8	4	4	4.750	1	33/8	¼	1¼	5/16-24	3¾-12	3-12	5.939	13
	4½	4½	5.250	1	37/8	¼	1¼	5/16-24	4¼-12	3¼-12	6.439	13
8	5	5	5.750	1	4¼	¼	1¼	5/16-24	4¾-12	3½-12	6.939	13
	5½	5½	6.250	1	45/8	¼	1¼	5/16-24	5¼-12	4-12	7.439	13

Add Stroke

6
63/8
67/16
611/16
69/16
613/16
71/16
711/16
715/16
81/16
83/16
85/16
89/16
91/16
95/16
95/16
109/16
109/16
109/16
109/16
11¾
11¾
11¾
11¾
13
13
13
13
13

Pressure Limitations For Model 65-B and 65-R

Rod Dia.	1¾"	2"	2½"	3"	3½"	4"	4½"	5"	5½"
Bore Sizes	Pressure (PSI)								
4	2400	2400	2400						
5		2400	2400	2270	1940				
6			1800	1800	1800	1800			
7				1800	1800	1550	1370	1190	
8					1730	1440	1310	1180	1050

Miller H Series Hydraulic Cylinders

Square Flange/Cap End 1½"–8" Bore Cylinders

Model 66-B (NFPA MF6) Bolted Bushing Square Flange/Cap End

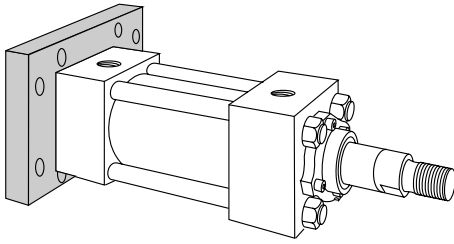

Mounting Dimensions (See tables on opposite page)

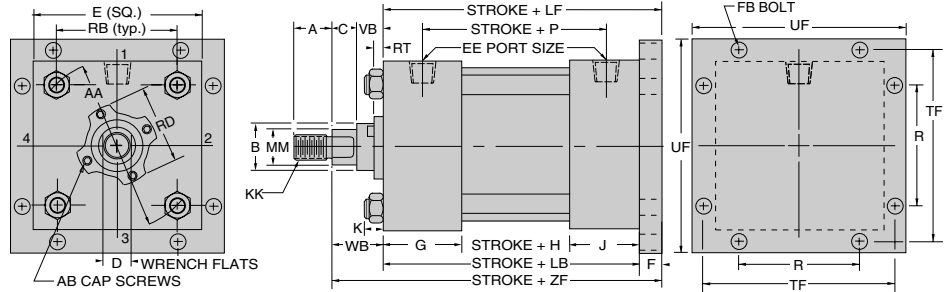

Note: High tensile mounting bolts should be used. Hardened flat washers should be used on 2½" through 8" bore cylinders.

Model 66-R (NFPA MF6) Square Retainer Held Bushing Square Flange/Cap End

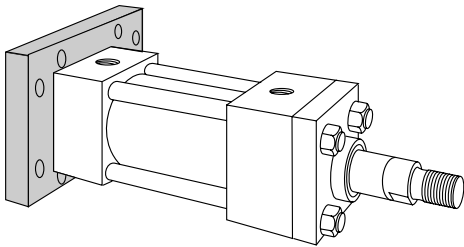

Mounting Dimensions (See tables on opposite page)

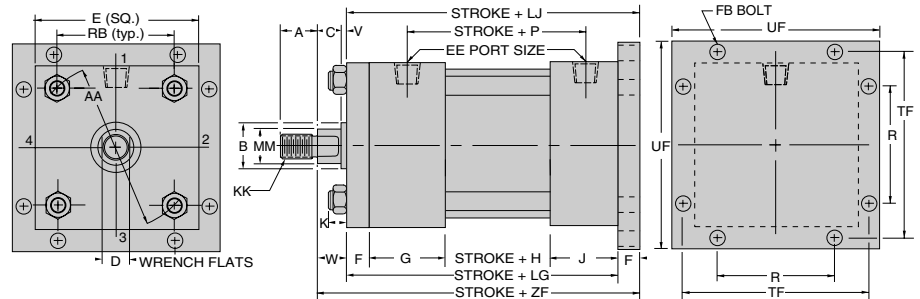

Note: High tensile mounting bolts should be used. Hardened flat washers should be used on 2½" through 8" bore cylinders.

Common Rod End Styles & Dimensions

For additional standard rod ends, see "Rod End Styles and Dimensions" page.

Style No. 2-Standard Threaded on Turndown Section

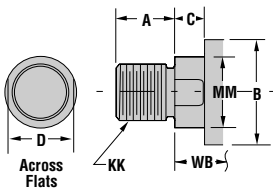

Style No. 4 Short Rod End-Internal Threads

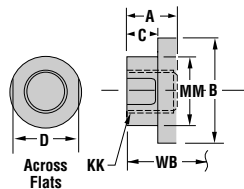

Style No. 5 Threaded Intermediate Male

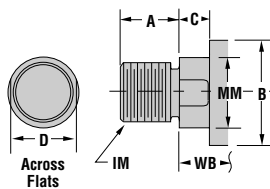

Style No. 6 Studded Rod End (Available Thru 2" Rod Diameter)

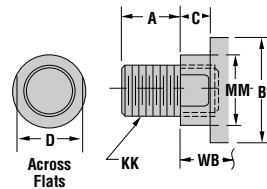

"Special" Thread Style X

Special thread, extension, rod eye, blank, etc., are also available.

To order, specify "Style X" and give desired dimensions for KK, A, WB or W. If otherwise special, furnish dimensioned sketch.

Pressure Limitations For Model 66-B and 66-R

Bore	4	5	6	7	8
Pressure (PSI)	2400	2400	1800	1800	1730

Miller H Series Hydraulic Cylinders

Square Flange/Cap End 1½"–8" Bore Cylinders

Cylinder Body Dimensions

Bore Size	E	F	G	J	K	R	AA	*EE		FB	RB	TF	UF
								SAE	NPTF				
1½	2½	¾	1¾	1½	¾	1.63	2.3	-8	½	¾	1.63	3/16	4¼
2	3	5/8	1¾	1½	7/16	2.05	2.9	-8	½	½	2.05	4/8	5¼
2½	3½	5/8	1¾	1½	7/16	2.55	3.6	-8	½	½	2.55	4/8	5½
3¼	4½	¾	2	1¾	9/16	3.25	4.6	-12	¾	5/8	3.25	5/8	7¼
4	5	7/8	2	1¾	9/16	3.82	5.4	-12	¾	5/8	3.82	6/8	7½
5	6½	7/8	2	1¾	13/16	4.95	7.0	-12	¾	7/8	4.95	8/16	9¼
6	7½	1	2¼	2¼	15/16	5.73	8.1	-16	1	1	5.73	9/16	11¼
7	8½	1	2¾	2¾	1	6.58	9.3	-20	1¼	1½	6.58	10/8	12½
8	9½	1	3	3	1¼	7.50	10.6	-24	1½	1¼	7.50	11/16	14

* SAE ports are standard, NPTF ports are available at no extra charge.
Note: Mounting holes are 1/16" larger than bolt sizes (FB) shown.

Add Stroke

H	LB	LF	LG	P	LJ
1¾	4½	5	5	2¾	5¾
1¾	4½	5¼	5¼	2¾	5¾
1½	4¾	5¾	5¾	3	6
1¾	5½	6¼	6¼	3½	7
2	5¾	6¾	6¾	3¾	7½
2½	6¼	7½	7½	4¼	8
2¾	7¾	8¾	8¾	4¾	9¾
3	8½	9½	—	5¾	—
3½	9½	10½	—	6½	—

Rod End Dimensions

Bore Size	Rod Dia (MM)	A	B -.001 to -.003	C	D	V	W	AB	IM Style 5	KK Styles 2,4&6	RD (Max.)	RT	VB	WB
1½	5/8	¾	1.125	¾	½	¼	5/8	10-32	½-20	7/16-20	1.972	.316	5/8	1
	1	1½	1.500	½	7/8	½	1	—	7/8-14	¾-16	—	—	—	—
2	1	1½	1.500	½	7/8	¼	¾	¼-28	7/8-14	¾-16	2.472	.328	7/8	1¾
	1¾	1½	2.000	5/8	1½	¾	1	—	1¼-12	1-14	—	—	—	—
2½	1	1½	1.500	½	7/8	¼	¾	¼-28	7/8-14	¾-16	2.472	.328	7/8	1¾
	1¾	1½	2.000	5/8	1½	¾	1	¼-28	1¼-12	1-14	2.972	.328	1	1½
	1¾	2	2.375	¾	1½	½	1¼	¼-28	1½-12	1¼-12	3.470	.313	1½	1¾
3¼	1¾	1½	2.000	5/8	1½	¼	7/8	¼-28	1¼-12	1-14	2.972	.328	1	1½
	1¾	2	2.375	¾	1½	¾	1½	¼-28	1½-12	1¼-12	3.470	.313	1½	1¾
	2	2¼	2.625	7/8	1½	¾	1¼	¼-28	1¾-12	1½-12	3.720	.313	1½	2
4	1¾	2	2.375	¾	1½	¼	1	¼-28	1½-12	1¼-12	3.470	.313	1½	1¾
	2	2¼	2.625	7/8	1½	¼	1½	¼-28	1¾-12	1½-12	3.720	.313	1½	2
	2½	3	3.125	1	2¼	¾	1¾	¼-28	2¼-12	1¾-12	4.252	.313	1¼	2¼
5	2	2¼	2.625	7/8	1½	¼	1½	¼-28	1¾-12	1½-12	3.720	.313	1½	2
	2½	3	3.125	1	2¼	¾	1¾	¼-28	2¼-12	1¾-12	4.252	.313	1¼	2¼
	3	3½	3.750	1	2½	¾	1¾	¼-28	2¾-12	2¼-12	4.752	.313	1¼	2¼
6	3½	3½	4.250	1	3	¾	1¾	¼-28	3¼-12	2½-12	5.252	.313	1¼	2¼
	2½	3	3.125	1	2¼	¼	1¼	¼-28	2¼-12	1¾-12	4.252	.313	1¼	2¼
	3	3½	3.750	1	2½	¼	1¼	¼-28	2¾-12	2¼-12	4.752	.313	1¼	2¼
	3½	3½	4.250	1	3	¼	1¼	¼-28	3¼-12	2½-12	5.252	.313	1¼	2¼
7	4	4	4.750	1	3¾	¼	1¼	5/16-24	3¾-12	3-12	5.939	.610	1¼	2¼
	3	3½	3.750	1	2½	—	—	¼-28	2¾-12	2¼-12	4.752	.313	1¼	2¼
	3½	3½	4.250	1	3	—	—	¼-28	3¼-12	2½-12	5.252	.313	1¼	2¼
	4½	4½	5.250	1	3¾	—	—	5/16-24	4¼-12	3¼-12	6.439	.610	1¼	2¼
	5	5	5.750	1	4¼	—	—	5/16-24	4¾-12	3½-12	6.939	.610	1¼	2¼
8	3½	3½	4.250	1	3	—	—	¼-28	3¼-12	2½-12	5.252	.313	1¼	2¼
	4	4	4.750	1	3¾	—	—	5/16-24	3¾-12	3-12	5.939	.610	1¼	2¼
	4½	4½	5.250	1	3¾	—	—	5/16-24	4¼-12	3¼-12	6.439	.610	1¼	2¼
	5	5	5.750	1	4¼	—	—	5/16-24	4¾-12	3½-12	6.939	.610	1¼	2¼
	5½	5½	6.250	1	4¾	—	—	5/16-24	5¼-12	4-12	7.439	.610	1¼	2¼

Add Stroke

ZF
6
6¾
6½
6¾
6¾
7
7¼
7¾
8¼
8¼
8½
8½
8¾
9¼
9¾
9¾
9¾
10½
10½
10½
10½
11¼
11¼
11¼
11¼
11¼
12¾
12¾
12¾
12¾
12¾

Miller H Series Hydraulic Cylinders

Rectangular Head/Cap 1½"–8" Bore Cylinders

Model 67-B (NFPA ME5) Bolted Bushing Rectangular Head

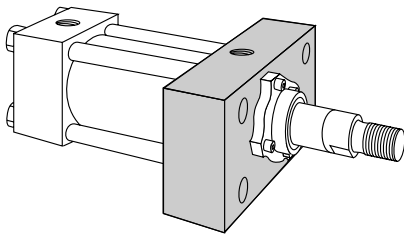

Mounting Dimensions (See tables on opposite page)

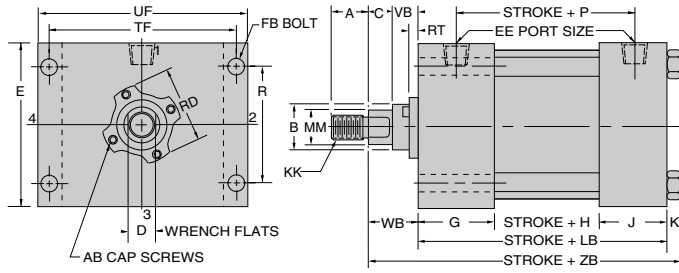

Note: High tensile mounting bolts should be used. Hardened flat washers should be used on 2½" through 8" bore cylinders. Not available in Retainer Held Bushing construction.

Model 68-B (NFPA ME6) Bolted Bushing Rectangular Cap

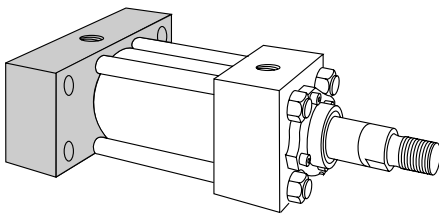

Mounting Dimensions (See tables on opposite page)

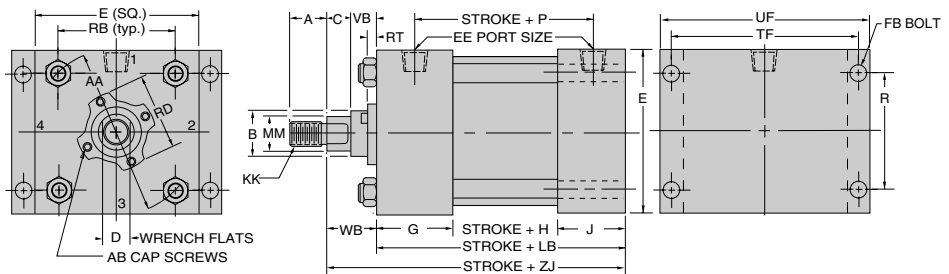

Note: High tensile mounting bolts should be used. Hardened flat washers should be used on 2½" through 8" bore cylinders.

Model 68-R (NFPA ME6) Square Retainer Held Bushing Rectangular Cap End

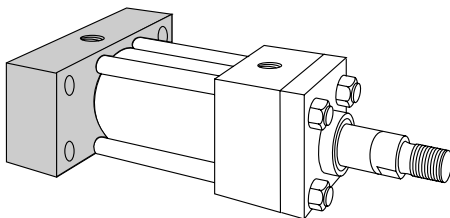

Mounting Dimensions (See tables on opposite page)

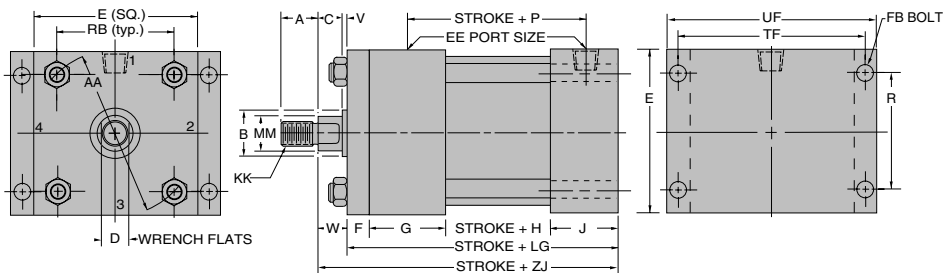

Note: High tensile mounting bolts should be used. Hardened flat washers should be used on 2½" through 8" bore cylinders.

Common Rod End Styles & Dimensions

For additional standard rod ends, see "Rod End Styles and Dimensions" page.

Style No. 2-Standard Threaded on Turndown Section

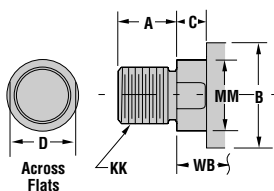

Style No. 4 Short Rod End-Internal Threads

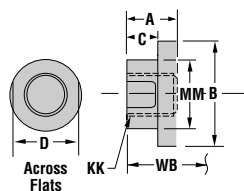

Style No. 5 Threaded Intermediate Male

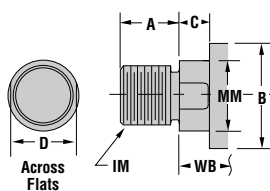

Style No. 6 Studded Rod End (Available Thru 2" Rod Diameter)

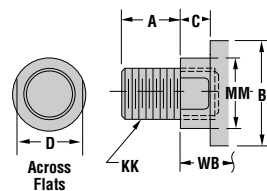

"Special" Thread Style X
Special thread, extension, rod eye, blank, etc., are also available.

To order, specify "Style X" and give desired dimensions for KK, A, WB or W. If otherwise special, furnish dimensioned sketch.

Miller H Series Hydraulic Cylinders

Rectangular Head/Cap 1½"–8" Bore Cylinders

Cylinder Body Dimensions

Bore Size	E	F	G	J	K	R	AA	*EE		FB	RB	TF	UF
								SAE	NPTF				
1½	2½	¾	1¾	1½	¾	1.63	2.3	-8	½	¾	1.63	3¼ ₁₆	4¼
2	3	⅝	1¾	1½	7 ₁₆	2.05	2.9	-8	½	½	2.05	4⅛	5⅛
2½	3½	⅝	1¾	1½	7 ₁₆	2.55	3.6	-8	½	½	2.55	4⅝	5⅝
3¼	4½	¾	2	1¾	9 ₁₆	3.25	4.6	-12	¾	⅝	3.25	5⅞	7⅞
4	5	⅞	2	1¾	9 ₁₆	3.82	5.4	-12	¾	⅝	3.82	6⅜	7⅝
5	6½	⅞	2	1¾	13 ₁₆	4.95	7.0	-12	¾	⅞	4.95	83 ₁₆	9¾
6	7½	1	2¼	2¼	15 ₁₆	5.73	8.1	-16	1	1	5.73	97 ₁₆	11¼
7	8½	—	2¾	2¾	1	6.58	9.3	-20	1¼	1⅛	6.58	105 ₈	125 ₈
8	9½	—	3	3	1¼	7.50	10.6	-24	1½	1¼	7.50	1113 ₁₆	14

Add Stroke

H	LB	±LD	LG	P
1¾	4⅝	4⅞	5	2⅞
1¾	4⅝	4⅞	5¼	2⅞
1½	4¾	5	5⅝	3
1¾	5½	5¾	6¼	3½
2	5¾	6	6⅝	3¾
2½	6¼	6½	7⅞	4¼
2⅞	7⅞	7⅞	8⅜	4⅞
3	8½	8½	—	5⅜
3½	9½	9½	—	6⅛

* SAE ports are standard, NPTF ports are available at no extra charge. ±LD dimension is for double rod end models. See Double Rod End page.
Note: Mounting holes are 1/16" larger than bolt sizes (FB) shown.

Rod End Dimensions

Bore Size	Rod Dia (MM)	A	B -.001 to -.003	C	D	V	W	AB	IM Style 5	KK Styles 2,4&6	RD (Max.)	RT	VB	WB
1½	5/8	¾	1.125	¾	½	¼	5/8	10-32	½-20	7/16-20	1.972	.316	5/8	1
	**1	1⅛	1.500	½	7/8	½	1	¼-28	7/8-14	¾-16	2.472	.328	7/8	1⅜
2	1	1⅛	1.500	½	7/8	¼	¾	¼-28	7/8-14	¾-16	2.472	.328	7/8	1⅜
	**1⅜	1⅝	2.000	5/8	1⅛	¾	1	¼-28	1¼-12	1-14	2.972	.328	1	1⅝
2½	1	1⅛	1.500	½	7/8	¼	¾	¼-28	7/8-14	¾-16	2.472	.328	7/8	1⅜
	1⅜	1⅝	2.000	5/8	1⅛	¾	1	¼-28	1¼-12	1-14	2.972	.328	1	1⅝
	1¾	2	2.375	¾	1½	½	1¼	¼-28	1½-12	1¼-12	3.470	.313	1⅛	1⅞
3¼	1⅜	1⅝	2.000	5/8	1⅛	¼	7/8	¼-28	1¼-12	1-14	2.972	.328	1	1⅝
	1¾	2	2.375	¾	1½	¾	1⅛	¼-28	1½-12	1¼-12	3.470	.313	1⅛	1⅞
4	2	2¼	2.625	7/8	1½	¾	1¼	¼-28	1¾-12	1½-12	3.720	.313	1⅛	2
	1¾	2	2.375	¾	1½	¼	1	¼-28	1½-12	1¼-12	3.470	.313	1⅛	1⅞
5	2	2¼	2.625	7/8	1½	¼	1⅛	¼-28	1¾-12	1½-12	3.720	.313	1⅛	2
	2½	3	3.125	1	2¼	¾	1⅜	¼-28	2¼-12	1⅞-12	4.252	.313	1¼	2¼
	3	3½	3.750	1	2⅝	¾	1⅜	¼-28	2¾-12	2¼-12	4.752	.313	1¼	2¼
6	3½	3½	4.250	1	3	¾	1⅜	¼-28	3¼-12	2½-12	5.252	.313	1¼	2¼
	2½	3	3.125	1	2¼	¼	1¼	¼-28	2¼-12	1⅞-12	4.252	.313	1¼	2¼
	3	3½	3.750	1	2⅝	¼	1¼	¼-28	2¾-12	2¼-12	4.752	.313	1¼	2¼
	3½	3½	4.250	1	3	¼	1¼	¼-28	3¼-12	2½-12	5.252	.313	1¼	2¼
7	4	4	4.750	1	3⅝	¼	1¼	5/16-24	3¾-12	3-12	5.939	.610	1¼	2¼
	3	3½	3.750	1	2⅝	—	—	¼-28	2¾-12	2¼-12	4.752	.313	1¼	2¼
	3½	3½	4.250	1	3	—	—	¼-28	3¼-12	2½-12	5.252	.313	1¼	2¼
	4½	4½	5.250	1	3⅞	—	—	5/16-24	4¼-12	3¼-12	6.439	.610	1¼	2¼
	5	5	5.750	1	4¼	—	—	5/16-24	4¾-12	3½-12	6.939	.610	1¼	2¼
8	3½	3½	4.250	1	3	—	—	¼-28	3¼-12	2½-12	5.252	.313	1¼	2¼
	4	4	4.750	1	3⅝	—	—	5/16-24	3¾-12	3-12	5.939	.610	1¼	2¼
	4½	4½	5.250	1	3⅞	—	—	5/16-24	4¼-12	3¼-12	6.439	.610	1¼	2¼
	5	5	5.750	1	4¼	—	—	5/16-24	4¾-12	3½-12	6.939	.610	1¼	2¼
5½	5½	6.250	1	4⅝	—	—	5/16-24	5¼-12	4-12	7.439	.610	1¼	2¼	

Add Stroke

ZB	ZJ
6	5⅝
6⅞	6
67 ₁₆	6
611 ₁₆	6¼
69 ₁₆	6⅛
613 ₁₆	6⅜
7⅞	6⅝
711 ₁₆	7⅞
715 ₁₆	7⅜
8⅞	7½
83 ₁₆	7⅞
85 ₁₆	7¾
89 ₁₆	8
9⅞	8¼
95 ₁₆	8½
99 ₁₆	8½
95 ₁₆	8½
109 ₁₆	9⅝
109 ₁₆	9⅝
109 ₁₆	9⅝
109 ₁₆	9⅝
11¾	10¾
11¾	10¾
11¾	10¾
11¾	10¾
13	11¾
13	11¾
13	11¾
13	11¾

**1½" Bore with 1" Rod Diameter and 2" Bore with 1⅜" Rod Diameter. Not Available with Bolted Bushing on Model 68.

Miller H Series Hydraulic Cylinders

Side Lug 1½"–8" Bore Cylinders

Model 72-B (NFPA MS2) Bolted Bushing Side Lug

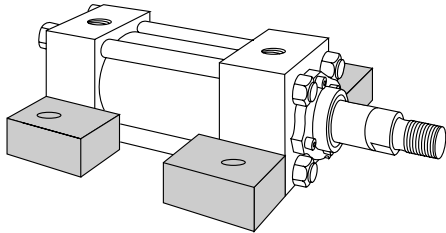

Mounting Dimensions (See tables on opposite page)

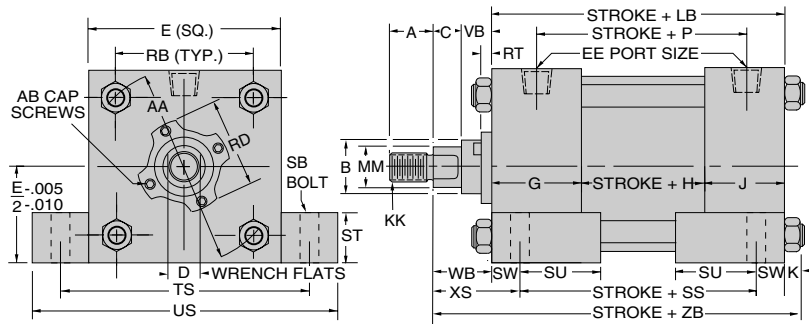

Note: Lugs should be blocked, or a "K" retainer should be mounted on the appropriate end to absorb hydraulic or mechanical shock. Bolts should not carry shear load. See Keying and Pinning Cylinders page.

Model 72-R (NFPA MS2) Square Retainer Held Bushing Side Lug

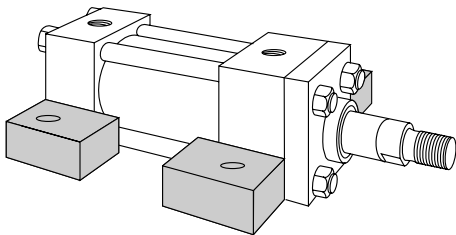

Mounting Dimensions (See tables on opposite page)

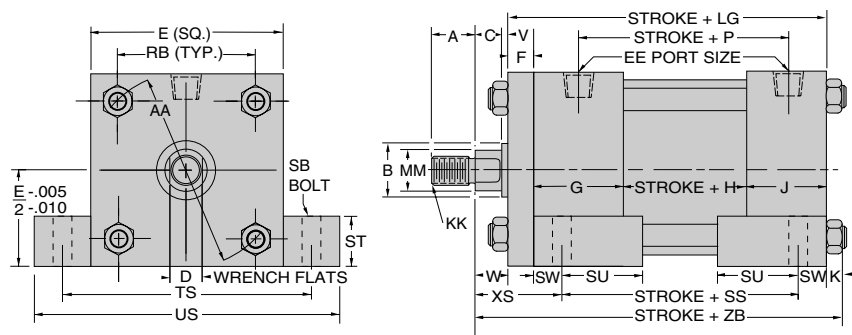

Note: Lugs should be blocked, or a "K" retainer should be mounted on the appropriate end to absorb hydraulic or mechanical shock. Bolts should not carry shear load. See Keying and Pinning Cylinders page.

Common Rod End Styles & Dimensions

For additional standard rod ends, see "Rod End Styles and Dimensions" page.

Style No. 2-Standard Threaded on Turndown Section

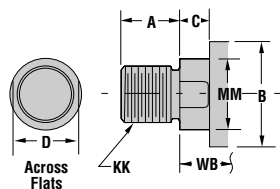

Style No. 4 Short Rod End-Internal Threads

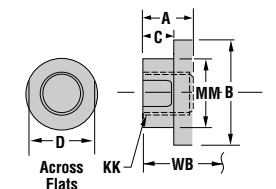

Style No. 5 Threaded Intermediate Male

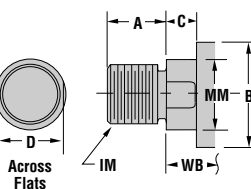

Style No. 6 Studded Rod End (Available Thru 2" Rod Diameter)

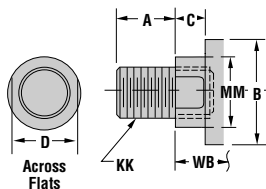

"Special" Thread Style X

Special thread, extension, rod eye, blank, etc., are also available.

To order, specify "Style X" and give desired dimensions for KK, A, WB or W. If otherwise special, furnish dimensioned sketch.

Pressure Limitations For Models 72-B & 72-R

Bore	1½	2	2½	3¼	4	5	6	7	8
Pressure (PSI)	3000	3000	2640	2280	1510	1440	1400	1480	1420

Model 72 cylinders have mounting lugs welded to the head and cap, and are considered to be a fixed mount that does not absorb force on its centerline. The plane of the mounting surface is not through the centerline of the cylinder, and for this reason Model 72 cylinders produce a turning moment as the cylinder applies force to the load. This turning moment tends to rotate the cylinder about its mounting bolts. If the cylinder is not well secured to the machine member on which it is mounted or the load is not well-guided, this turning moment results in side load applied to rod bushing and piston bearings. To avoid this problem, Model 72 cylinders should be specified with a stroke length at least equal to the bore size.

Miller H Series Hydraulic Cylinders

Side Lug 1½"–8" Bore Cylinders

Cylinder Body Dimensions

Bore Size	E	F	G	J	K	AA	*EE		RB	SB	ST	SU	SW	TS	US
							SAE	NPTF							
1½	2½	¾	1¾	1½	¾	2.3	-8	½	1.63	¾	½	15/16	¾	3¼	4
2	3	5/8	1¾	1½	7/16	2.9	-8	½	2.05	½	¾	1¼	½	4	5
2½	3½	5/8	1¾	1½	7/16	3.6	-8	½	2.55	¾	1	19/16	11/16	47/8	6¼
3¼	4½	¾	2	1¾	9/16	4.6	-12	¾	3.25	¾	1	19/16	11/16	57/8	7¼
4	5	7/8	2	1¾	9/16	5.4	-12	¾	3.82	1	1¼	2	7/8	6¾	8½
5	6½	7/8	2	1¾	13/16	7.0	-12	¾	4.95	1	1¼	2	7/8	8¼	10
6	7½	1	2¼	2¼	15/16	8.1	-16	1	5.73	1¼	1½	2½	1½	9¾	12
7	8½	—	2¾	2¾	1	9.3	-20	1¼	6.58	1½	1¾	27/8	1¾	11¼	14
8	9½	—	3	3	1¼	10.6	-24	1½	7.50	1½	1¾	27/8	1¾	12¼	15

Add Stroke

H	LB	±LD	LG	P	±SS
1¾	45/8	47/8	5	27/8	37/8
1¾	45/8	47/8	5¼	27/8	35/8
1½	4¾	5	53/8	3	33/8
1¾	5½	5¾	6¼	3½	41/8
2	5¾	6	63/8	3¾	4
2½	6¼	6½	71/8	4¼	4½
27/8	73/8	73/8	83/8	47/8	51/8
3	8½	8½	—	53/8	5¾
3½	9½	9½	—	63/8	6¾

* SAE ports are standard, NPTF ports are available at no extra charge.

‡ LD dimension is for double rod end models. See Double Rod End page. For end to end bolt centerlines on double rod-end cylinders, use common dimension "Stroke plus LD" instead of "Stroke Plus SS" and subtract dimension "SW" from each end.

Note: Mounting holes are 1/16" larger than bolt sizes (SB) shown.

Rod End Dimensions

Bore Size	Rod Dia (MM)	A	B -.001 to -.003	C	D	V	W	AB	IM Style 5	KK Styles 2,4&6	RD (Max.)	RT	VB	WB	XS
1½	5/8	¾	1.125	¾	½	¼	5/8	10-32	½-20	7/16-20	1.972	.316	5/8	1	1¾
	1	11/8	1.500	½	7/8	½	1	—	7/8-14	¾-16	—	—	—	—	1¾
2	1	11/8	1.500	½	7/8	¼	¾	¼-28	7/8-14	¾-16	2.472	.328	7/8	1¾	17/8
	1¾	15/8	2.000	5/8	11/8	¾	1	—	1¼-12	1-14	—	—	—	—	21/8
2½	1	11/8	1.500	½	7/8	¼	¾	¼-28	7/8-14	¾-16	2.472	.328	7/8	1¾	21/16
	1¾	15/8	2.000	5/8	11/8	¾	1	¼-28	1¼-12	1-14	2.972	.328	1	15/8	25/16
	1¾	2	2.375	¾	1½	½	1¼	¼-28	1½-12	1¼-12	3.470	.313	11/8	17/8	29/16
3¼	1¾	15/8	2.000	5/8	11/8	¼	7/8	¼-28	1¼-12	1-14	2.972	.328	1	15/8	25/16
	1¾	2	2.375	¾	1½	¾	11/8	¼-28	1½-12	1¼-12	3.470	.313	11/8	17/8	29/16
	2	2¼	2.625	7/8	111/16	¾	1¼	¼-28	1¾-12	1½-12	3.720	.313	11/8	2	211/16
4	1¾	2	2.375	¾	1½	¼	1	¼-28	1½-12	1¼-12	3.470	.313	11/8	17/8	29/16
	2	2¼	2.625	7/8	111/16	¼	11/8	¼-28	1¾-12	1½-12	3.720	.313	11/8	2	27/8
	2½	3	3.125	1	21/16	¾	1¾	¼-28	2¼-12	17/8-12	4.252	.313	1¼	2¼	31/8
5	2	2¼	2.625	7/8	111/16	¼	11/8	¼-28	1¾-12	1½-12	3.720	.313	11/8	2	27/8
	2½	3	3.125	1	21/16	¾	1¾	¼-28	2¼-12	17/8-12	4.252	.313	1¼	2¼	31/8
	3	3½	3.750	1	25/8	¾	1¾	¼-28	2¾-12	2¼-12	4.752	.313	1¼	2¼	31/8
	3½	3½	4.250	1	3	¾	1¾	¼-28	3¼-12	2½-12	5.252	.313	1¼	2¼	31/8
6	2½	3	3.125	1	21/16	¼	1¼	¼-28	2¼-12	17/8-12	4.252	.313	1¼	2¼	33/8
	3	3½	3.750	1	25/8	¼	1¼	¼-28	2¾-12	2¼-12	4.752	.313	1¼	2¼	33/8
	3½	3½	4.250	1	3	¼	1¼	¼-28	3¼-12	2½-12	5.252	.313	1¼	2¼	33/8
	4	4	4.750	1	33/8	¼	1¼	5/16-24	3¾-12	3-12	5.939	.610	1¼	2¼	33/8
7	3	3½	3.750	1	25/8	—	—	¼-28	2¾-12	2¼-12	4.752	.313	1¼	2¼	35/8
	3½	3½	4.250	1	3	—	—	¼-28	3¼-12	2½-12	5.252	.313	1¼	2¼	35/8
	4	4	4.750	1	33/8	—	—	5/16-24	3¾-12	3-12	5.939	.610	1¼	2¼	35/8
	4½	4½	5.250	1	37/8	—	—	5/16-24	4¼-12	3¼-12	6.439	.610	1¼	2¼	35/8
	5	5	5.750	1	4¼	—	—	5/16-24	4¾-12	3½-12	6.939	.610	1¼	2¼	35/8
8	3½	3½	4.250	1	3	—	—	¼-28	3¼-12	2½-12	5.252	.313	1¼	2¼	35/8
	4	4	4.750	1	33/8	—	—	5/16-24	3¾-12	3-12	5.939	.610	1¼	2¼	35/8
	4½	4½	5.250	1	37/8	—	—	5/16-24	4¼-12	3¼-12	6.439	.610	1¼	2¼	35/8
	5	5	5.750	1	4¼	—	—	5/16-24	4¾-12	3½-12	6.939	.610	1¼	2¼	35/8
	5½	5½	6.250	1	45/8	—	—	5/16-24	5¼-12	4-12	7.439	.610	1¼	2¼	35/8

Add Stroke

ZB
6
63/8
67/16
611/16
69/16
613/16
71/16
711/16
715/16
81/16
83/16
85/16
89/16
91/16
95/16
99/16
109/16
109/16
109/16
109/16
11¾
11¾
11¾
11¾
11¾
13
13
13
13
13

Miller H Series Hydraulic Cylinders

Centerline Lug
1½"–8" Bore Cylinders

Model 73-B (NFPA MS3) Bolted Bushing Centerline Lug

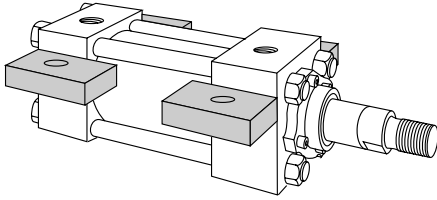

Mounting Dimensions (See tables on opposite page)

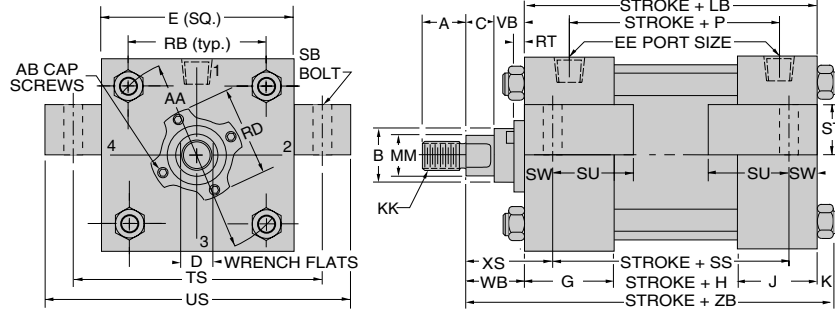

Note: Lugs should be blocked, or pinned on the appropriate end to absorb hydraulic or mechanical shock. Bolts should not carry shear load. See Keying and Pinning Cylinders page.

Model 73-R (NFPA MS3) Square Retainer Held Bushing Centerline Lug

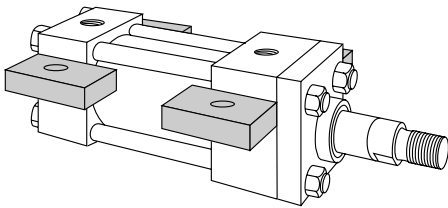

Mounting Dimensions (See tables on opposite page)

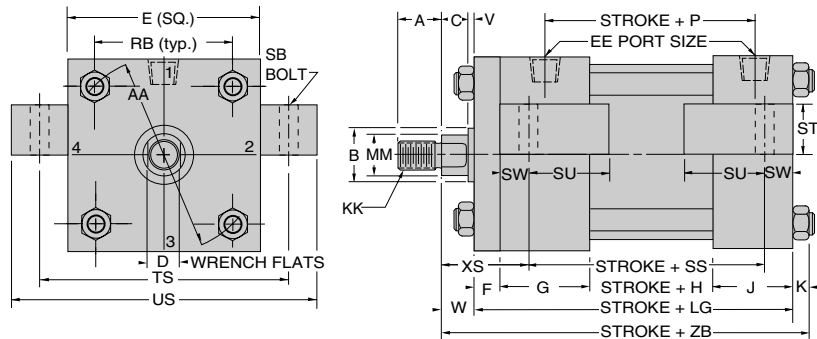

Note: Lugs should be blocked, or pinned on the appropriate end to absorb hydraulic or mechanical shock. Bolts should not carry shear load. See Keying and Pinning Cylinders page.

Common Rod End Styles & Dimensions

For additional standard rod ends, see "Rod End Styles and Dimensions" page.

Style No. 2-Standard Threaded on Turndown Section

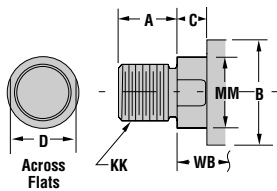

Style No. 4 Short Rod End-Internal Threads

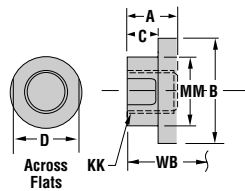

Style No. 5 Threaded Intermediate Male

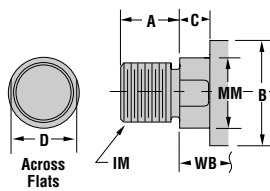

Style No. 6 Studded Rod End (Available Thru 2" Rod Diameter)

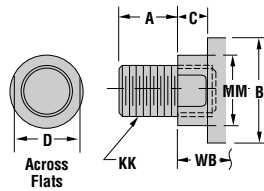

"Special" Thread Style X

Special thread, extension, rod eye, blank, etc., are also available.

To order, specify "Style X" and give desired dimensions for KK, A, WB or W. If otherwise special, furnish dimensioned sketch.

Miller H Series Hydraulic Cylinders

Centerline Lug 1½"-8" Bore Cylinders

Cylinder Body Dimensions

Bore Size	E	F	G	J	K	AA	*EE		RB	SB	ST	SU	SW	TS	US
							SAE	NPTF							
1½	2½	¾	1¾	1½	¾	2.3	-8	½	1.63	¾	½	15/16	¾	3¼	4
2	3	5/8	1¾	1½	7/16	2.9	-8	½	2.05	½	¾	1¼	½	4	5
2½	3½	5/8	1¾	1½	7/16	3.6	-8	½	2.55	¾	1	19/16	11/16	47/8	6¼
3¼	4½	¾	2	1¾	9/16	4.6	-12	¾	3.25	¾	1	19/16	11/16	57/8	7¼
4	5	7/8	2	1¾	9/16	5.4	-12	¾	3.82	1	1¼	2	7/8	6¾	8½
5	6½	7/8	2	1¾	13/16	7.0	-12	¾	4.95	1	1¼	2	7/8	8¼	10
6	7½	1	2¼	2¼	15/16	8.1	-16	1	5.73	1¼	1½	2½	1½	9¾	12
7	8½	—	2¾	2¾	1	9.3	-20	1¼	6.58	1½	1¾	27/8	1¾	11¼	14
8	9½	—	3	3	1¼	10.6	-24	1½	7.50	1½	1¾	27/8	1¾	12¼	15

Add Stroke

H	LB	±LD	LG	P	±SS
1¾	49/8	47/8	5	27/8	37/8
19/8	49/8	47/8	5¼	27/8	35/8
1½	4¾	5	53/8	3	33/8
1¾	5½	5¾	6¼	3½	41/8
2	5¾	6	65/8	3¾	4
2½	6¼	6½	71/8	4¼	4½
27/8	73/8	73/8	83/8	47/8	51/8
3	8½	8½	—	53/8	5¾
3½	9½	9½	—	61/8	6¾

* SAE ports are standard, NPTF ports are available at no extra charge.

‡ LD dimension is for double rod end models. See Double Rod End page. For end to end bolt centerlines on double rod-end cylinders, use common dimension "Stroke plus LD" instead of "Stroke Plus SS" and subtract dimension "SW" from each end.

Note: Mounting holes are 1/16" larger than bolt sizes (SB) shown.

Rod End Dimensions

Bore Size	Rod Dia (MM)	A	B -.001 to -.003	C	D	V	W	AB	IM Style 5	KK Styles 2,4&6	RD (Max.)	RT	VB	WB	XS
1½	5/8	¾	1.125	¾	½	¼	5/8	10-32	½-20	7/16-20	1.972	.316	5/8	1	13/8
	1	11/8	1.500	½	7/8	½	1	—	7/8-14	¾-16	—	—	—	—	1¾
2	1	11/8	1.500	½	7/8	¼	¾	¼-28	7/8-14	¾-16	2.472	.328	7/8	13/8	17/8
	13/8	15/8	2.000	5/8	11/8	¾	1	—	1¼-12	1-14	—	—	—	—	2½
2½	1	11/8	1.500	½	7/8	¼	¾	¼-28	7/8-14	¾-16	2.472	.328	7/8	13/8	21/16
	13/8	15/8	2.000	5/8	11/8	¾	1	¼-28	1¼-12	1-14	2.972	.328	1	15/8	25/16
3¼	1¾	2	2.375	¾	1½	½	1¼	¼-28	1½-12	1¼-12	3.470	.313	1½	17/8	29/16
	13/8	15/8	2.000	5/8	11/8	¼	7/8	¼-28	1¼-12	1-14	2.972	.328	1	15/8	25/16
4	2	2¼	2.625	7/8	1½	¾	1¼	¼-28	1¾-12	1½-12	3.720	.313	1½	2	21½/16
	1¾	2	2.375	¾	1½	¼	1	¼-28	1½-12	1¼-12	3.470	.313	1½	17/8	23¼/16
5	2½	3	3.125	1	21/16	¾	13/8	¼-28	2¼-12	17/8-12	4.252	.313	1¼	2¼	31/8
	2	2¼	2.625	7/8	1½	¼	11/8	¼-28	1¾-12	1½-12	3.720	.313	1½	2	27/8
6	3	3½	3.750	1	25/8	¾	13/8	¼-28	2¾-12	2¼-12	4.752	.313	1¼	2¼	35/8
	3½	3½	4.250	1	3	¾	13/8	¼-28	3¼-12	2½-12	5.252	.313	1¼	2¼	39/8
7	2½	3	3.125	1	21/16	¼	1¼	¼-28	2¼-12	17/8-12	4.252	.313	1¼	2¼	33/8
	3	3½	3.750	1	25/8	¼	1¼	¼-28	2¾-12	2¼-12	4.752	.313	1¼	2¼	37/8
8	3½	3½	4.250	1	3	¼	1¼	¼-28	3¼-12	2½-12	5.252	.313	1¼	2¼	41/8
	4	4	4.750	1	33/8	¼	1¼	5/16-24	3¾-12	3-12	5.939	.610	1¼	2¼	45/8
9	3	3½	3.750	1	25/8	—	—	¼-28	2¾-12	2¼-12	4.752	.313	1¼	2¼	35/8
	3½	3½	4.250	1	3	—	—	¼-28	3¼-12	2½-12	5.252	.313	1¼	2¼	39/8
10	4	4	4.750	1	33/8	—	—	5/16-24	3¾-12	3-12	5.939	.610	1¼	2¼	45/8
	4½	4½	5.250	1	37/8	—	—	5/16-24	4¼-12	3¼-12	6.439	.610	1¼	2¼	49/8
11	5	5	5.750	1	4¼	—	—	5/16-24	4¾-12	3½-12	6.939	.610	1¼	2¼	53/8
	3½	3½	4.250	1	3	—	—	¼-28	3¼-12	2½-12	5.252	.313	1¼	2¼	35/8
12	4	4	4.750	1	33/8	—	—	5/16-24	3¾-12	3-12	5.939	.610	1¼	2¼	45/8
	4½	4½	5.250	1	37/8	—	—	5/16-24	4¼-12	3¼-12	6.439	.610	1¼	2¼	49/8
13	5	5	5.750	1	4¼	—	—	5/16-24	4¾-12	3½-12	6.939	.610	1¼	2¼	53/8
	5½	5½	6.250	1	45/8	—	—	5/16-24	5¼-12	4-12	7.439	.610	1¼	2¼	57/8

Add Stroke

ZB
6
63/8
67/16
611/16
69/16
613/16
71/16
711/16
715/16
81/16
83/16
85/16
89/16
91/16
95/16
95/16
95/16
109/16
109/16
109/16
109/16
113/4
113/4
113/4
113/4
113/4
13
13
13
13
13

Miller H Series Hydraulic Cylinders

Side Tapped
1½" - 8" Bore Cylinders

Model 74-B (NFPA MS4) Bolted Bushing Side Tapped

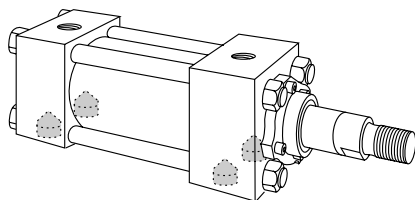

Note: A "K" retainer should be mounted on the appropriate end to absorb hydraulic or mechanical shock. Bolts should not carry shear load. See Keying and Pinning Cylinders page.

Mounting Dimensions (See tables on opposite page)

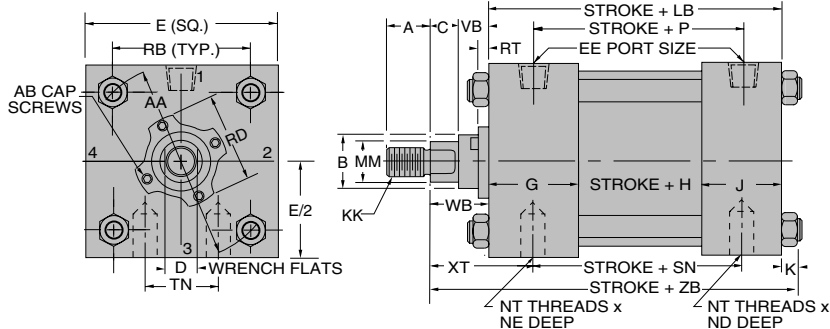

Model 74-R (NFPA MS4) Square Retainer Held Bushing Side Tapped

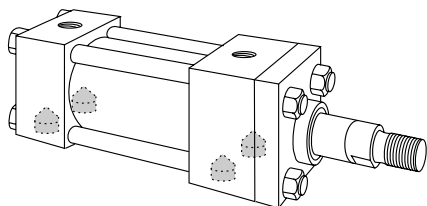

Note: A "K" retainer should be mounted on the appropriate end to absorb hydraulic or mechanical shock. Bolts should not carry shear load. See Keying and Pinning Cylinders page.

Mounting Dimensions (See tables on opposite page)

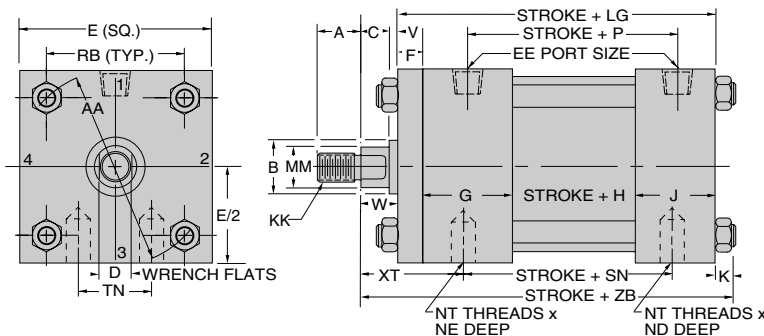

Common Rod End Styles & Dimensions

For additional standard rod ends, see "Rod End Styles and Dimensions" page.

Style No. 2-Standard Threaded on Turndown Section

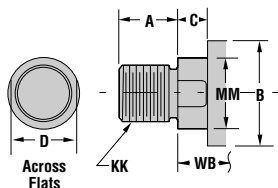

Style No. 4 Short Rod End-Internal Threads

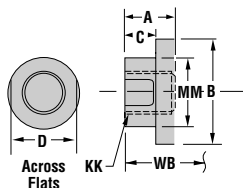

Style No. 5 Threaded Intermediate Male

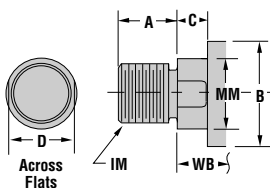

Style No. 6 Studded Rod End (Available Thru 2" Rod Diameter)

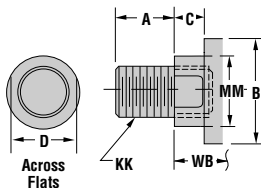

"Special" Thread Style X

Special thread, extension, rod eye, blank, etc., are also available.

To order, specify "Style X" and give desired dimensions for KK, A, WB or W. If otherwise special, furnish dimensioned sketch.

Pressure Limitations For Model 74-B and 74-R

Rod Dia.	5/8	1	1 3/8	1 3/4	2	2 1/2	3	3 1/2	4	4 1/2	5	5 1/2
Bore Sizes	Pressure (PSI)											
1 1/2	2820	2160										
2		2750	1980									
2 1/2		2580	2220	1860								
3 1/4			2580	2820	2460							
4				2400	2400	2280						
5					2400	2400	2490	2250				
6						1800	1800	2640	2250			
7							1800	1800	1800	1800	1800	
8									1800	1800	1800	1800

Model 74 cylinders have side tapped holes for flush mounting, and are considered to be a fixed mount that does not absorb force on its centerline. The plane of the mounting surface is not through the centerline of the cylinder, and for this reason Model 74 cylinders produce a turning moment as the cylinder applies force to the load. This turning moment tends to rotate the cylinder about its mounting bolts. If the cylinder is not well secured to the machine member on which it is mounted or the load is not well-guided, this turning moment results in side load applied to rod bushing and piston bearings. To avoid this problem, Model 74 cylinders should be specified with a stroke length at least equal to the bore size.

Miller H Series Hydraulic Cylinders

End Lug
1½"–8" Bore Cylinders

Model 77-B (NFPA MS7) Bolted Bushing End Lug

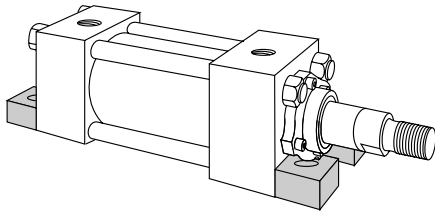

Note: Mounting bolts should not carry shear load. Lugs should be blocked or a "K" retainer should be mounted on the appropriate end to absorb hydraulic or mechanical shock. See Keying and Pinning Cylinders page.

Mounting Dimensions (See tables on opposite page)

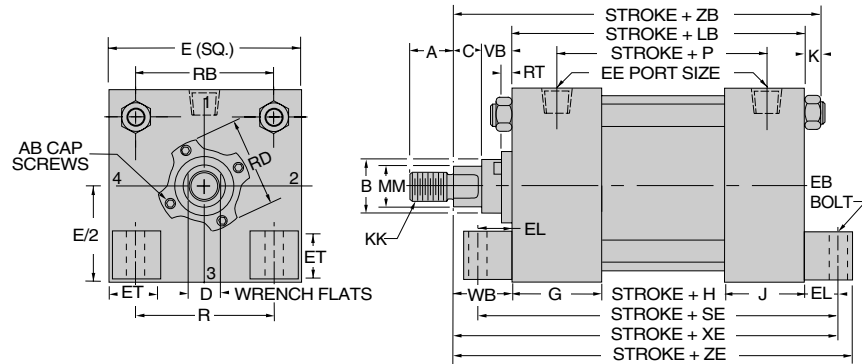

Model 77-R (NFPA MS7) Square Retainer Held Bushing End Lug

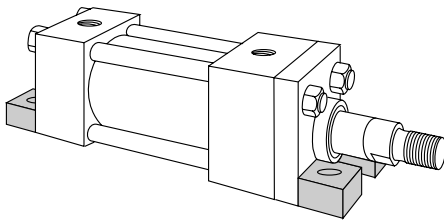

Note: Mounting bolts should not carry shear load. Lugs should be blocked or a "K" retainer should be mounted on the appropriate end to absorb hydraulic or mechanical shock. See Keying and Pinning Cylinders page.

Mounting Dimensions (See tables on opposite page)

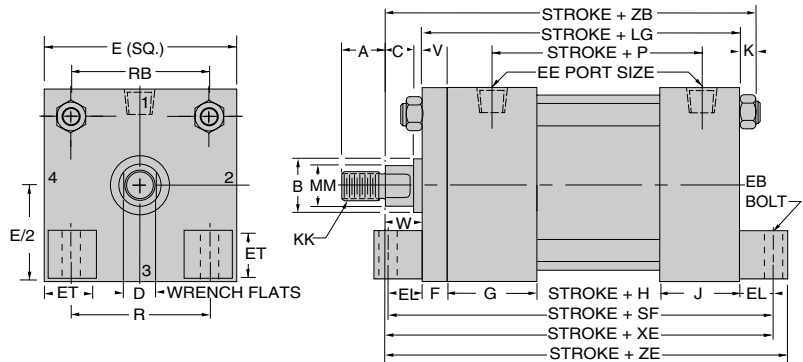

Common Rod End Styles & Dimensions

For additional standard rod ends, see "Rod End Styles and Dimensions" page.

Style No. 2-Standard Threaded on Turndown Section

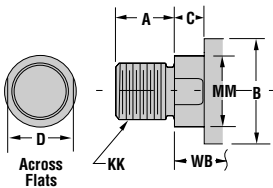

Style No. 4 Short Rod End-Internal Threads

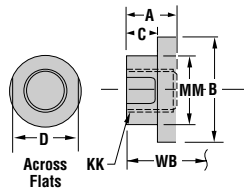

Style No. 5 Threaded Intermediate Male

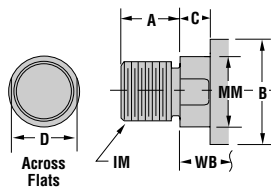

Style No. 6 Studded Rod End (Available Thru 2" Rod Diameter)

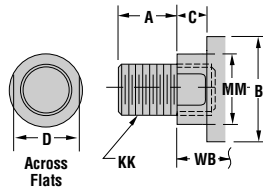

"Special" Thread Style X

Special thread, extension, rod eye, blank, etc., are also available.

To order, specify "Style X" and give desired dimensions for KK, A, WB or W. If otherwise special, furnish dimensioned sketch.

Pressure Limitations For Models 77-B & 77-R

Bore	1½	2	2½	3¼	4	5	6	7	8
Pressure (PSI)	2820	2760	2580	2520	2400	2400	1800	1800	1800

Model 77 cylinders have lugs connected to the ends, and are considered to be a fixed mount that does not absorb force on its centerline. The plane of the mounting surface is not through the centerline of the cylinder, and for this reason Model 77 cylinders produce a turning moment as the cylinder applies force to the load. This turning moment tends to rotate the cylinder about its mounting bolts. If the cylinder is not well secured to the machine member on which it is mounted or the load is not well-guided, this turning moment results in side load applied to rod bushing and piston bearings. To avoid this problem, Model 77 cylinders should be specified with a stroke length at least equal to the bore size.

Miller H Series Hydraulic Cylinders

End Lug 1½"–8" Bore Cylinders

Cylinder Body Dimensions

Bore Size	E	F	G	J	K	R	EB	*EE		EL	ET	RB
								SAE	NPTF			
1½	2½	¾	1¾	1½	¾	1.63	¾	-8	½	⅞	13/16	1.63
2	3	⅝	1¾	1½	7/16	2.05	½	-8	½	15/16	7/8	2.05
2½	3½	⅝	1¾	1½	7/16	2.55	½	-8	½	15/16	7/8	2.55
3¼	4½	¾	2	1¾	9/16	3.25	⅝	-12	¾	1⅛	13/16	3.25
4	5	⅞	2	1¾	9/16	3.82	⅝	-12	¾	1⅛	1⅛	3.82
5	6½	⅞	2	1¾	13/16	4.95	⅞	-12	¾	1½	115/32	4.95
6	7½	1	2¼	2¼	15/16	5.73	1	-16	1	111/16	111/16	5.73
7	8½	—	2¾	2¾	1	6.58	1⅛	-20	1¼	113/16	127/32	6.58
8	9½	—	3	3	1¼	7.50	1¼	-24	1½	2	115/16	7.50

* SAE ports are standard, NPTF ports are available at no extra charge.

‡ LD dimension is for double rod end models. See Double Rod End page. For overall length on double rod-end cylinder, use common dimension "Stroke plus LD" instead of figures "ZE", "XE", "SF" and "SE", and add end lug dimensions.

Note: Mounting holes are 1/16" larger than bolt sizes (FB) shown.

Add Stroke

H	LB	‡LD	LG	P	‡SE	‡SF
1⅜	4⅝	4⅞	5	2⅞	6⅜	6¾
1⅜	4⅝	4⅞	5¼	2⅞	6½	7⅛
1½	4¾	5	5⅜	3	6⅝	7¼
1¾	5½	5¾	6¼	3½	7¾	8½
2	5¾	6	6⅝	3¾	8	8⅞
2½	6¼	6½	7⅛	4¼	9¼	10⅞
2⅞	7⅜	7⅞	8⅜	4⅞	10¾	11¾
3	8½	8½	—	5⅜	12⅞	13⅞
3½	9½	9½	—	6⅞	13½	14½

Rod End Dimensions

Bore Size	Rod Dia (MM)	A	B -.001 to -.003	C	D	V	W	AB	IM Style 5	KK Styles 2,4&6	RD (Max.)	RT	VB	WB
1½	5/8	¾	1.125	¾	½	¼	5/8	10-32	½-20	7/16-20	1.972	.316	5/8	1
	1	1⅛	1.500	½	7/8	½	1	—	7/8-14	¾-16	—	—	—	—
2	1	1⅛	1.500	½	7/8	¼	¾	¼-28	7/8-14	¾-16	2.472	.328	7/8	1⅜
	1⅜	1⅝	2.000	⅝	1⅛	¾	1	—	1¼-12	1-14	—	—	—	—
2½	1	1⅛	1.500	½	7/8	¼	¾	¼-28	7/8-14	¾-16	2.472	.328	7/8	1⅜
	1⅜	1⅝	2.000	⅝	1⅛	¾	1	¼-28	1¼-12	1-14	2.972	.328	1	1⅝
	1¾	2	2.375	¾	1½	½	1¼	—	1½-12	1¼-12	—	—	—	—
3¼	1⅜	1⅝	2.000	⅝	1⅛	¼	7/8	¼-28	1¼-12	1-14	2.972	.328	1	1⅝
	1¾	2	2.375	¾	1½	¾	1⅛	¼-28	1½-12	1¼-12	3.470	.313	1⅛	1⅞
	2	2¼	2.625	7/8	11/16	¾	1¼	—	1¾-12	1½-12	—	—	—	—
4	1¾	2	2.375	¾	1½	¼	1	¼-28	1½-12	1¼-12	3.470	.313	1⅛	1⅞
	2	2¼	2.625	7/8	11/16	¼	1⅛	¼-28	1¾-12	1½-12	3.720	.313	1⅛	2
	2½	3	3.125	1	21/16	¾	1⅜	—	2¼-12	1⅞-12	—	—	—	—
5	2	2¼	2.625	7/8	11/16	¼	1⅛	¼-28	1¾-12	1½-12	3.720	.313	1⅛	2
	2½	3	3.125	1	21/16	¾	1⅜	¼-28	2¼-12	1⅞-12	4.252	.313	1¼	2¼
	3	3½	3.750	1	2⅝	¾	1⅜	¼-28	2¾-12	2¼-12	4.752	.313	1¼	2¼
	3½	3½	4.250	1	3	¾	1⅜	—	3¼-12	2½-12	—	—	—	—
6	2½	3	3.125	1	21/16	¼	1¼	¼-28	2¼-12	1⅞-12	4.252	.313	1¼	2¼
	3	3½	3.750	1	2⅝	¼	1¼	¼-28	2¾-12	2¼-12	4.752	.313	1¼	2¼
	3½	3½	4.250	1	3	¼	1¼	¼-28	3¼-12	2½-12	5.252	.313	1¼	2¼
	4	4	4.750	1	3⅜	¼	1¼	—	3¾-12	3-12	—	—	—	—
7	3	3½	3.750	1	2⅝	—	—	¼-28	2¾-12	2¼-12	4.752	.313	1¼	2¼
	3½	3½	4.250	1	3	—	—	¼-28	3¼-12	2½-12	5.252	.313	1¼	2¼
	4	4	4.750	1	3⅜	—	—	5/16-24	3¾-12	3-12	5.939	.610	1¼	2¼
	4½	4½	5.250	1	3⅞	—	—	5/16-24	4¼-12	3¼-12	6.439	.610	1¼	2¼
8	3½	3½	4.250	1	3	—	—	¼-28	3¼-12	2½-12	5.252	.313	1¼	2¼
	4	4	4.750	1	3⅜	—	—	5/16-24	3¾-12	3-12	5.939	.610	1¼	2¼
	4½	4½	5.250	1	3⅞	—	—	5/16-24	4¼-12	3¼-12	6.439	.610	1¼	2¼
	5	5	5.750	1	4¼	—	—	5/16-24	4¾-12	3½-12	6.939	.610	1¼	2¼
5½	5½	6.250	1	4⅝	—	—	5/16-24	5¼-12	4-12	7.439	.610	1¼	2¼	

Add Stroke

‡XE	ZB	‡ZE
6½	6	6⅞
6⅞	6⅞	7¼
615/16	67/16	71/16
73/16	611/16	711/16
71/16	69/16	79/16
75/16	613/16	713/16
79/16	71/16	81/16
8¼	711/16	8⅞
8½	715/16	9⅞
8⅝	81/16	9¼
8¾	83/16	9⅜
8⅞	85/16	9½
9⅞	89/16	9¾
9¾	91/16	10½
10	95/16	10¾
10	97/16	10¾
10	99/16	10¾
115/16	109/16	123/16
115/16	109/16	123/16
115/16	109/16	123/16
115/16	109/16	123/16
129/16	11¾	139/16
129/16	11¾	139/16
129/16	11¾	139/16
129/16	11¾	139/16
13¾	13	14⅞
13¾	13	14⅞
13¾	13	14⅞
13¾	13	14⅞

Miller H Series Hydraulic Cylinders

End Angle
1½"–6" Bore Cylinders

Model 71-R (NFPA MS1) Square Retainer Held Bushing End Angle

Mounting Dimensions (See tables on opposite page)

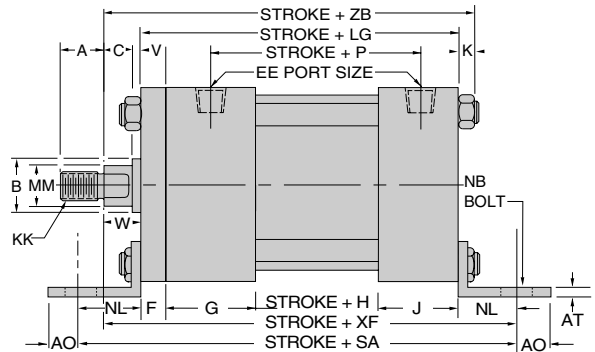
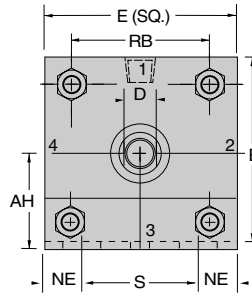
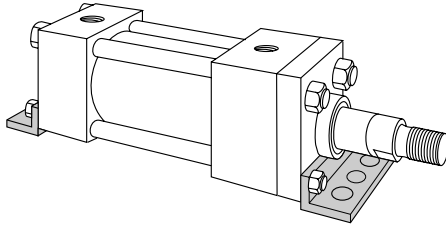

Note: Mounting bolts should not carry shear load. End angles should be blocked or a "K" retainer should be mounted on the appropriate end to absorb hydraulic or mechanical shock. See Keying and Pinning Cylinders page.

Common Rod End Styles & Dimensions

For additional standard rod ends, see "Rod End Styles and Dimensions" page.

Style No. 2-Standard Threaded on Turndown Section

Style No. 4 Short Rod End-Internal Threads

Style No. 5 Threaded Intermediate Male

Style No. 6 Studded Rod End (Available Thru 2" Rod Diameter)

"Special" Thread Style X

Special thread, extension, rod eye, blank, etc., are also available.

To order, specify "Style X" and give desired dimensions for KK, A, WB or W. If otherwise special, furnish dimensioned sketch.

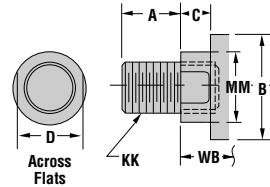
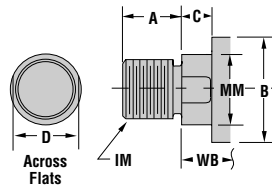
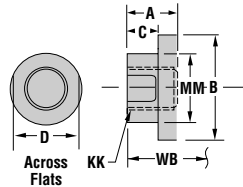
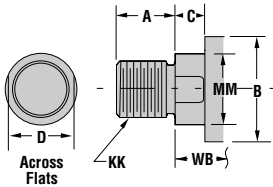

Pressure Limitation For Model 71-R

Bore	ALL
Pressure (PSI)	500

Model 71 cylinders have mounting angles connected to the ends, and are the weakest of the side mount styles. Model 71 cylinders should be limited to a maximum operating pressure of 500 psi and minimum stroke length of twice the bore size. For pressure rating of shorter strokes, consult the factory.

Miller H Series Hydraulic Cylinders

End Angle 1½"–6" Bore Cylinders

Cylinder Body Dimensions

Bore Size	E	F	G	J	K	S	AH	AO	AT	*EE		NB	NE	NL	RB
										SAE	NPTF				
1½	2½	¾	1¾	1½	¾	1¾	1¾	¾	1/8	-8	1/2	¾	¾	1	1.63
2	3	5/8	1¾	1½	7/16	2	1 11/16	1/2	1/8	-8	1/2	1/2	1/2	1¼	2.05
2½	3½	5/8	1¾	1½	7/16	2¾	1 15/16	9/16	1/8	-8	1/2	5/8	9/16	1 3/16	2.55
3¼	4½	¾	2	1¾	9/16	3 1/8	2 9/16	1 1/16	1/4	-12	¾	¾	1 1/16	1 13/16	3.25
4	5	7/8	2	1¾	9/16	3 1/4	2 13/16	7/8	1/4	-12	¾	1	7/8	2 1/8	3.82
5	6½	7/8	2	1¾	1 3/16	4¾	3 1 1/16	7/8	5/16	-12	¾	1	7/8	2 1/8	4.95
6	7½	1	2¼	2¼	1 5/16	5¾	4¼	1 1/16	¾	-16	1	1¼	1 1/16	2 7/16	5.73

Add Stroke

H	‡LD	LG	P	‡SA
1¾	4 7/8	5	2 7/8	7
1¾	4 7/8	5 1/4	2 7/8	7 3/4
1½	5	5 3/8	3	7 3/4
1¾	5 3/4	6 1/4	3 1/2	9 7/8
2	6	6 5/8	3 3/4	10 7/8
2½	6 1/2	7 1/8	4¼	11 3/8
2 7/8	7 3/8	8 3/8	4 7/8	13 1/4

* SAE ports are standard, NPTF ports are available at no extra charge.

‡ LD dimension is for double rod end models. See Double Rod End page. For overall length on double rod-end cylinder, use common dimension "Stroke plus LD" instead of figures "XF", and "SA", and add end angle dimensions.

Note: Mounting holes are 1/16" larger than bolt sizes (NB) shown.

Rod End Dimensions

Bore Size	Rod Dia (MM)	A	B -.001 to -.003	C	D	V	W	IM Style 5	KK Styles 2,4,6
1½	5/8	¾	1.125	¾	1/2	1/4	5/8	1/2-20	7/16-20
	1	1 1/8	1.500	1/2	7/8	1/2	1	7/8-14	¾-16
2	1	1 1/8	1.500	1/2	7/8	1/4	¾	7/8-14	¾-16
	1 3/8	1 5/8	2.000	5/8	1 1/8	¾	1	1 1/4-12	1-14
2½	1	1 1/8	1.500	1/2	7/8	1/4	¾	7/8-14	¾-16
	1 3/8	1 5/8	2.000	5/8	1 1/8	¾	1	1 1/4-12	1-14
	1 3/4	2	2.375	¾	1 1/2	1/2	1 1/4	1 1/2-12	1 1/4-12
3¼	1 3/8	1 5/8	2.000	5/8	1 1/8	1/4	7/8	1 1/4-12	1-14
	1 3/4	2	2.375	¾	1 1/2	¾	1 1/8	1 1/2-12	1 1/4-12
	2	2 1/4	2.625	7/8	1 11/16	¾	1 1/4	1 3/4-12	1 1/2-12
4	1 3/4	2	2.375	¾	1 1/2	1/4	1	1 1/2-12	1 1/4-12
	2	2 1/4	2.625	7/8	1 11/16	1/4	1 1/8	1 3/4-12	1 1/2-12
	2 1/2	3	3.125	1	2 1/16	¾	1 3/8	2 1/4-12	1 7/8-12
5	2	2 1/4	2.625	7/8	1 11/16	1/4	1 1/8	1 3/4-12	1 1/2-12
	2 1/2	3	3.125	1	2 1/16	¾	1 3/8	2 1/4-12	1 7/8-12
	3	3 1/2	3.750	1	2 5/8	¾	1 3/8	2 3/4-12	2 1/4-12
	3 1/2	3 1/2	4.250	1	3	¾	1 3/8	3 1/4-12	2 1/2-12
6	2 1/2	3	3.125	1	2 1/16	1/4	1 1/4	2 1/4-12	1 7/8-12
	3	3 1/2	3.750	1	2 5/8	1/4	1 1/4	2 3/4-12	2 1/4-12
	3 1/2	3 1/2	4.250	1	3	1/4	1 1/4	3 1/4-12	2 1/2-12
	4	4	4.750	1	3 3/8	1/4	1 1/4	3 3/4-12	3-12

Add Stroke

‡XF	ZB
6 5/8	6
7	6 3/8
7 1/4	6 7/16
7 1/2	6 1 1/16
7 5/16	6 9/16
7 9/16	6 13/16
7 13/16	7 1/16
8 15/16	7 1 1/16
9 3/16	7 15/16
9 5/16	8 1/16
9 3/4	8 3/16
9 7/8	8 5/16
10 1/8	8 9/16
10 3/8	9 1/16
10 5/8	9 5/16
10 5/8	9 5/16
10 5/8	9 5/16
12 1/16	10 9/16
12 1/16	10 9/16
12 1/16	10 9/16
12 1/16	10 9/16

Miller H Series Hydraulic Cylinders

Trunnion/Head End 1½" – 8" Bore Cylinders

Model 81-B (NFPA MT1) Bolted Bushing Trunnion Head End

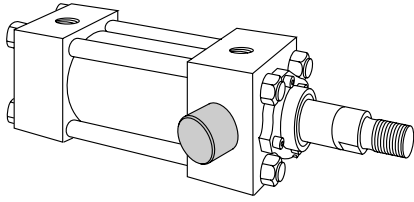

Note: Pins designed for shear (not bending) loads.

Mounting Dimensions (See tables on opposite page)

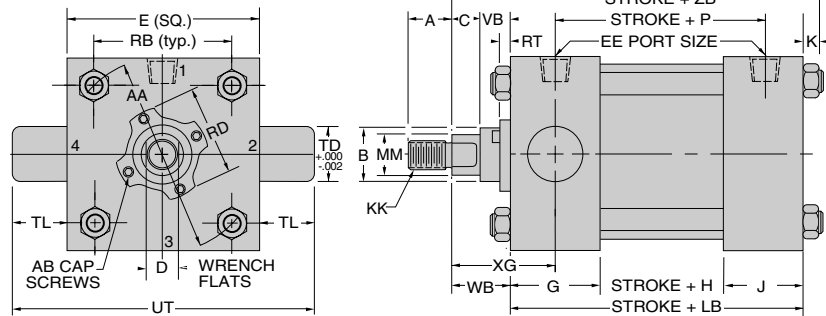

Model 81-R (NFPA MT1) Square Retainer Held Bushing Trunnion Head End

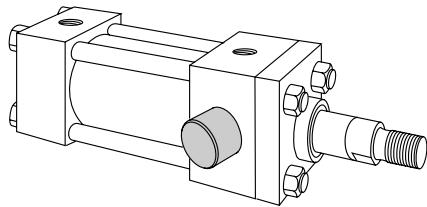

Note: Pins designed for shear (not bending) loads.

Mounting Dimensions (See tables on opposite page)

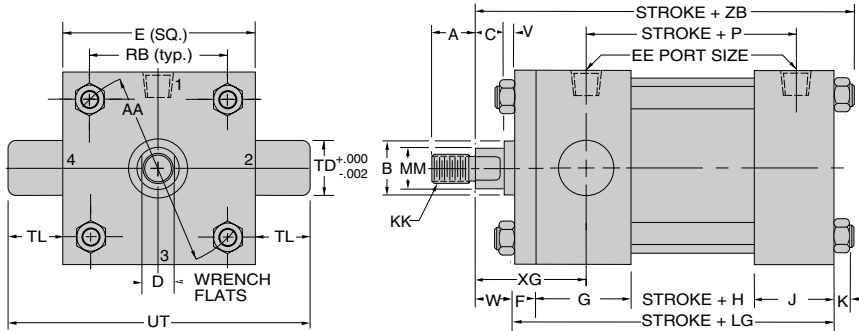

Common Rod End Styles & Dimensions

For additional standard rod ends, see "Rod End Styles and Dimensions" page.

Style No. 2-Standard Threaded on Turndown Section

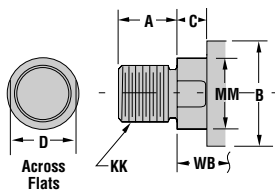

Style No. 4 Short Rod End-Internal Threads

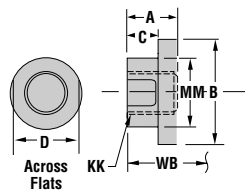

Style No. 5 Threaded Intermediate Male

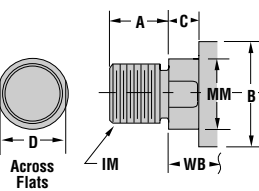

Style No. 6 Studded Rod End (Available Thru 2" Rod Diameter)

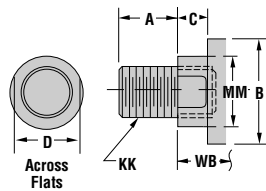

"Special" Thread Style X
Special thread, extension, rod eye, blank, etc., are also available.

To order, specify "Style X" and give desired dimensions for KK, A, WB or W. If otherwise special, furnish dimensioned sketch.

Pressure Limitations For Models 81-B & 81-R

Bore	4	5	6	7	8
Pressure (PSI)	2250	1440	1310	1260	1660

Miller H Series Hydraulic Cylinders

Trunnion/Cap End 1½"–8" Bore Cylinders

Model 82-B (NFPA MT2) Bolted Bushing Trunnion Cap End

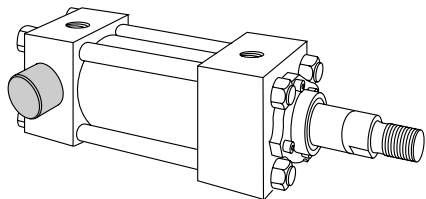

Note: Pins designed for shear (not bending) loads.

Mounting Dimensions (See tables on opposite page)

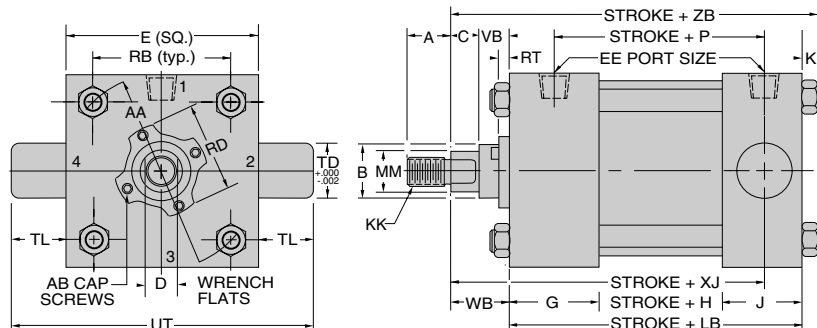

Model 82-R (NFPA MT2) Square Retainer Held Bushing Trunnion Cap End

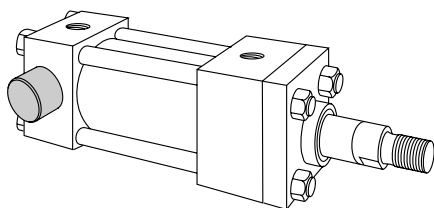

Note: Pins designed for shear (not bending) loads.

Mounting Dimensions (See tables on opposite page)

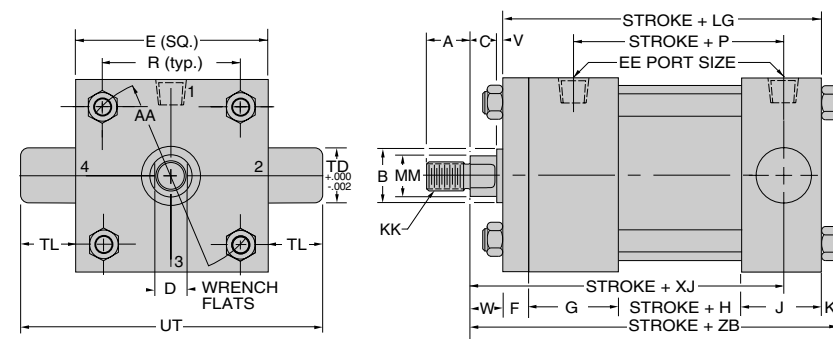

Common Rod End Styles & Dimensions

For additional standard rod ends, see "Rod End Styles and Dimensions" page.

Style No. 2-Standard Threaded on Turndown Section

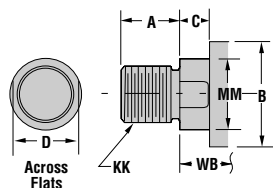

Style No. 4 Short Rod End-Internal Threads

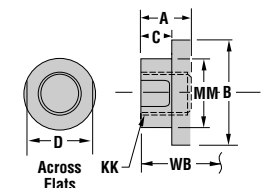

Style No. 5 Threaded Intermediate Male

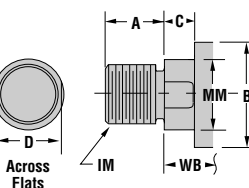

Style No. 6 Studded Rod End (Available Thru 2" Rod Diameter)

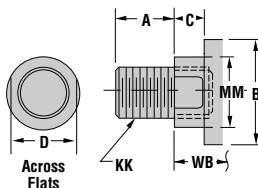

"Special" Thread Style X
Special thread, extension, rod eye, blank, etc., are also available.

To order, specify "Style X" and give desired dimensions for KK, A, WB or W. If otherwise special, furnish dimensioned sketch.

Pressure Limitations For Models 82-B & 82-R

Bore	4	5	6	7	8
Pressure (PSI)	2250	1440	1310	1260	1660

Miller H Series Hydraulic Cylinders

Trunnion/Cap End 1½"-8" Bore Cylinders

Cylinder Body Dimensions

Bore Size	E	F	G	J	K	AA	*EE		RB	TD	TL	UT
							SAE	NPTF				
1½	2½	¾	1¾	1½	¾	2.3	-8	½	1.63	1	1	4½
2	3	5/8	1¾	1½	7/16	2.9	-8	½	2.05	1¾	1¾	5¾
2½	3½	5/8	1¾	1½	7/16	3.6	-8	½	2.55	1¾	1¾	6¼
3¼	4½	¾	2	1¾	9/16	4.3	-12	¾	3.25	1¾	1¾	8
4	5	7/8	2	1¾	9/16	5.4	-12	¾	3.82	1¾	1¾	8½
5	6½	7/8	2	1¾	13/16	7.0	-12	¾	4.95	1¾	1¾	10
6	7½	1	2¼	2¼	15/16	8.1	-16	1	5.73	2	2	11½
7	8½	—	2¾	2¾	1	9.3	-20	1¼	6.58	2½	2½	13½
8	9½	—	3	3	1¼	10.6	-24	1½	7.50	3	3	15½

* SAE ports are standard, NPTF ports are available at no extra charge.

Add Stroke

H	LB	LG	P
1¾	45/8	5	27/8
1¾	45/8	5¼	27/8
1½	4¾	5¾	3
1¾	5½	6¼	3½
2	5¾	65/8	3¾
2½	6¼	71/8	4¼
27/8	7¾	8¾	47/8
3	8½	—	5¾
3½	9½	—	6½

Rod End Dimensions

Bore Size	Rod Dia (MM)	A	B -.001 to -.003	C	D	V	W	AB	IM Style 5	KK Styles 2,4&6	RD (Max.)	RT	VB	WB
1½	5/8	¾	1.125	¾	½	¼	5/8	10-32	½-20	7/16-20	1.972	.316	5/8	1
	1	11/8	1.500	½	7/8	½	1	—	7/8-14	¾-16	—	—	—	—
2	1	11/8	1.500	½	7/8	¼	¾	¼-28	7/8-14	¾-16	2.472	.328	7/8	1¾
	1¾	15/8	2.000	5/8	11/8	¾	1	—	1¼-12	1-14	—	—	—	—
2½	1	11/8	1.500	½	7/8	¼	¾	¼-28	7/8-14	¾-16	2.472	.328	7/8	1¾
	1¾	15/8	2.000	5/8	11/8	¾	1	¼-28	1¼-12	1-14	2.972	.328	1	15/8
	1¾	2	2.375	¾	1½	½	1¼	¼-28	1½-12	1¼-12	3.470	.313	11/8	17/8
3¼	1¾	15/8	2.000	5/8	11/8	¼	7/8	¼-28	1¼-12	1-14	2.972	.328	1	15/8
	1¾	2	2.375	¾	1½	¾	11/8	¼-28	1½-12	1¼-12	3.470	.313	11/8	17/8
	2	2¼	2.625	7/8	111/16	¾	1¼	¼-28	1¾-12	1½-12	3.720	.313	11/8	2
4	1¾	2	2.375	¾	1½	¼	1	¼-28	1½-12	1¼-12	3.470	.313	11/8	17/8
	2	2¼	2.625	7/8	111/16	¼	11/8	¼-28	1¾-12	1½-12	3.720	.313	11/8	2
	2½	3	3.125	1	21/16	¾	1¾	¼-28	2¼-12	17/8-12	4.252	.313	1¼	2¼
5	2	2¼	2.625	7/8	111/16	¼	11/8	¼-28	1¾-12	1½-12	3.720	.313	11/8	2
	2½	3	3.125	1	21/16	¾	1¾	¼-28	2¼-12	17/8-12	4.252	.313	1¼	2¼
	3	3½	3.750	1	25/8	¾	1¾	¼-28	2¾-12	2¼-12	4.752	.313	1¼	2¼
	3½	3½	4.250	1	3	¾	1¾	¼-28	3¼-12	2½-12	5.252	.313	1¼	2¼
6	2½	3	3.125	1	21/16	¼	1¼	¼-28	2¼-12	17/8-12	4.252	.313	1¼	2¼
	3	3½	3.750	1	25/8	¼	1¼	¼-28	2¾-12	2¼-12	4.752	.313	1¼	2¼
	3½	3½	4.250	1	3	¼	1¼	¼-28	3¼-12	2½-12	5.252	.313	1¼	2¼
	4	4	4.750	1	3¾	¼	1¼	5/16-24	3¾-12	3-12	5.939	.610	1¼	2¼
7	3	3½	3.750	1	25/8	—	—	¼-28	2¾-12	2¼-12	4.752	.313	1¼	2¼
	3½	3½	4.250	1	3	—	—	¼-28	3¼-12	2½-12	5.252	.313	1¼	2¼
	4	4	4.750	1	3¾	—	—	5/16-24	3¾-12	3-12	5.939	.610	1¼	2¼
	4½	4½	5.250	1	37/8	—	—	5/16-24	4¼-12	3¼-12	6.439	.610	1¼	2¼
	5	5	5.750	1	4¼	—	—	5/16-24	4¾-12	3½-12	6.939	.610	1¼	2¼
8	3½	3½	4.250	1	3	—	—	¼-28	3¼-12	2½-12	5.252	.313	1¼	2¼
	4	4	4.750	1	3¾	—	—	5/16-24	3¾-12	3-12	5.939	.610	1¼	2¼
	4½	4½	5.250	1	37/8	—	—	5/16-24	4¼-12	3¼-12	6.439	.610	1¼	2¼
	5	5	5.750	1	4¼	—	—	5/16-24	4¾-12	3½-12	6.939	.610	1¼	2¼
	5½	5½	6.250	1	45/8	—	—	5/16-24	5¼-12	4-12	7.439	.610	1¼	2¼

Add Stroke

XJ	ZB
47/8	6
5¼	6¾
5¼	67/16
5½	611/16
5¾	69/16
55/8	613/16
57/8	71/16
6¼	711/16
6½	75/16
65/8	81/16
6¾	83/16
67/8	85/16
71/8	89/16
7¾	91/16
75/8	95/16
75/8	95/16
75/8	95/16
8¾	109/16
8¾	109/16
8¾	109/16
8¾	109/16
9¾	11¾
9¾	11¾
9¾	11¾
9¾	11¾
9¾	11¾
10¼	13
10¼	13
10¼	13
10¼	13
10¼	13

Miller H Series Hydraulic Cylinders

Intermediate Trunnion 1½"–8" Bore Cylinders

Model 89-B (NFPA MT4) Bolted Bushing Intermediate Trunnion

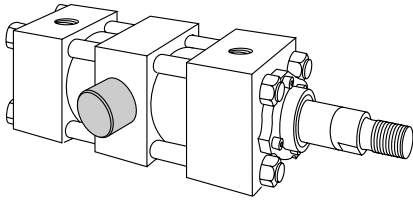

Note: Pins designed for shear (not bending) loads. Specify dimension "XI" when ordering.

Mounting Dimensions (See tables on opposite page)

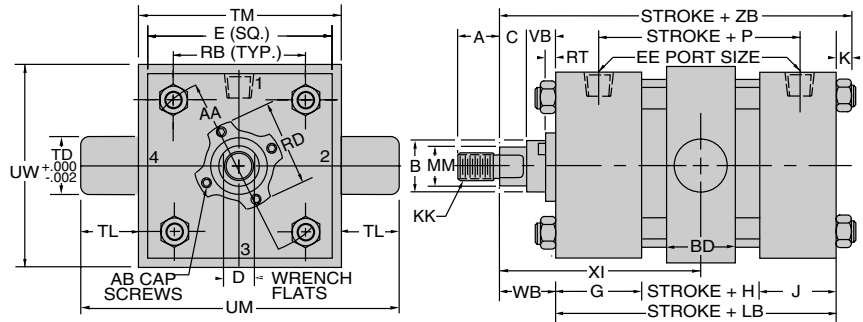

Model 89-R (NFPA MT4) Square Retainer Held Bushing Intermediate Trunnion

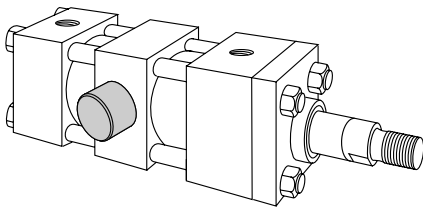

Note: Pins designed for shear (not bending) loads. Specify dimension "XI" when ordering.

Mounting Dimensions (See tables on opposite page)

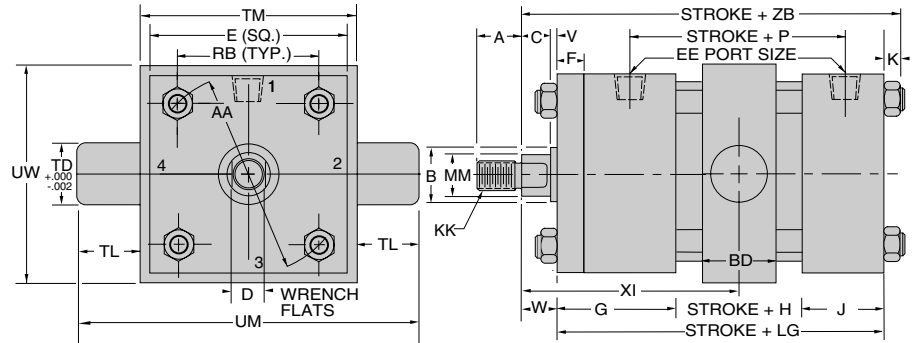

Common Rod End Styles & Dimensions

For additional standard rod ends, see "Rod End Styles and Dimensions" page.

Style No. 2-Standard Threaded on Turndown Section

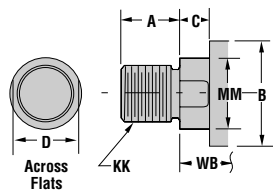

Style No. 4 Short Rod End-Internal Threads

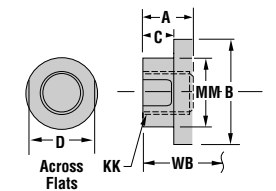

Style No. 5 Threaded Intermediate Male

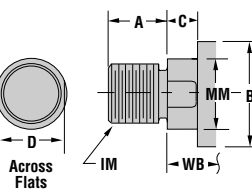

Style No. 6 Studded Rod End (Available Thru 2" Rod Diameter)

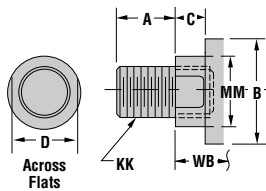

"Special" Thread Style X
Special thread, extension, rod eye, blank, etc., are also available.
To order, specify "Style X" and give desired dimensions for KK, A, WB or W. If otherwise special, furnish dimensioned sketch.

Pressure Limitations, Minimum XI Dimension and Minimum Stroke For Models 89-B & 89-R

Bore	1½	2	2½	3¼	4	5	6	7	8
Pressure (PSI)	3000	3000	3000	2530	1660	1060	1090	1260	820
Min. XI	3¾	4⅛	4.5	5⅛	5¾	5¾	6¼	7	7½
Min. Stroke	0	.125	.25	.5	1	.5	.625	1	1

Miller H Series Hydraulic Cylinders

Fixed Clevis
1½"–8" Bore Cylinders

Model 84-B (NFPA MP1)
Bolted Bushing
Fixed Clevis
(Pivot Pin Included)

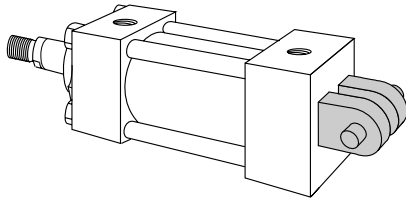

Mounting Dimensions
(See tables on opposite page)

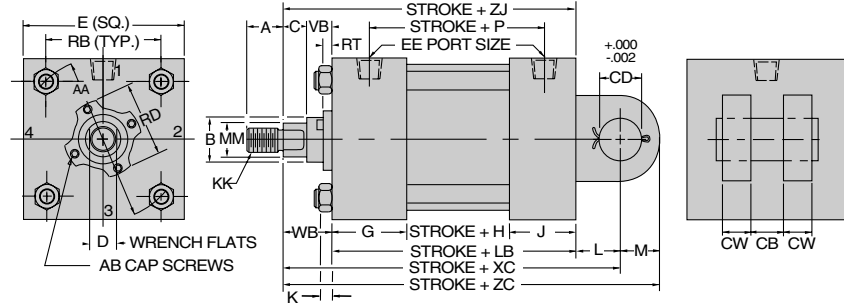

Model 84-R (NFPA MP1)
Square Retainer Held Bushing
Fixed Clevis
(Pivot Pin Included)

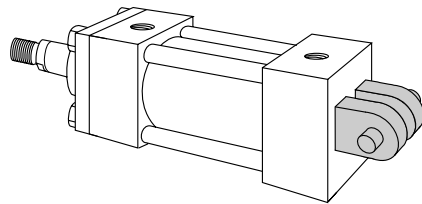

Mounting Dimensions
(See tables on opposite page)

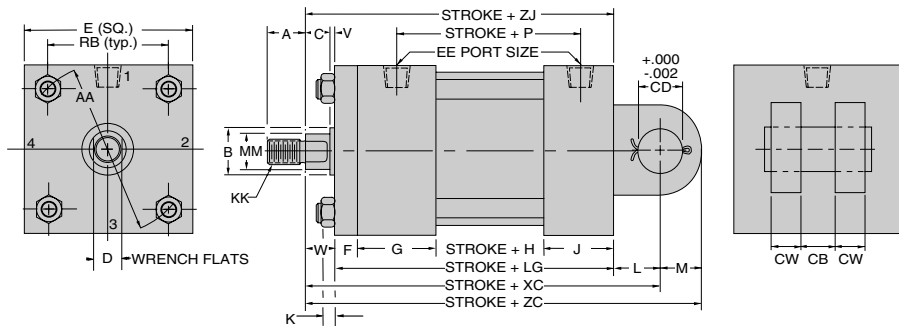

Common Rod End Styles & Dimensions

For additional standard rod ends, see "Rod End Styles and Dimensions" page.

Style No. 2-Standard
Threaded on Turndown Section

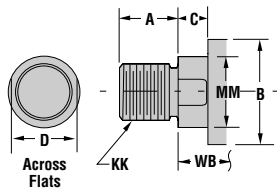

Style No. 4
Short Rod End-Internal Threads

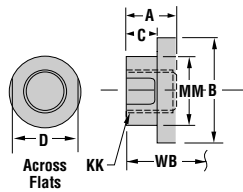

Style No. 5
Threaded Intermediate Male

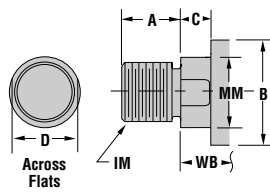

Style No. 6
Studded Rod End
(Available Thru 2" Rod Diameter)

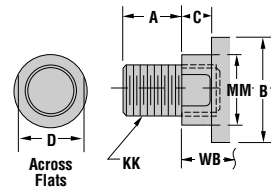

"Special" Thread Style X

Special thread, extension, rod eye, blank, etc., are also available.

To order, specify "Style X" and give desired dimensions for KK, A, WB or W. If otherwise special, furnish dimensioned sketch.

Miller H Series Hydraulic Cylinders

Fixed Clevis 1½"-8" Bore Cylinders

Cylinder Body Dimensions

Bore Size	E	F	G	J	K	L	M	AA	CB	CD	CW	*EE		RB
												SAE	NPTF	
1½	2½	¾	1¾	1½	¾	¾	½	2.3	¾	½	½	-8	½	1.63
2	3	¾	1¾	1½	7/16	1¼	¾	2.9	1¼	¾	5/8	-8	½	2.05
2½	3½	¾	1¾	1½	7/16	1¼	¾	3.6	1¼	¾	5/8	-8	½	2.55
3¼	4½	¾	2	1¾	9/16	1½	1	4.6	1½	1	¾	-12	¾	3.25
4	5	7/8	2	1¾	9/16	2½	1¾	5.4	2	1¾	1	-12	¾	3.82
5	6½	7/8	2	1¾	13/16	2¼	1¾	7.0	2½	1¾	1¼	-12	¾	4.95
6	7½	1	2¼	2¼	15/16	2½	2	8.1	2½	2	1¼	-16	1	5.73
7	8½	—	2¾	2¾	1	3	2½	9.3	3	2½	1½	-20	1¼	6.58
8	9½	—	3	3	1¼	3¼	2¾	10.6	3	3	1½	-24	1½	7.50

* SAE ports are standard, NPTF ports are available at no extra charge.

Add Stroke

H	LB	LG	P
1¾	4¾	5	2¾
1¾	4¾	5¼	2¾
1½	4¾	5¾	3
1¾	5½	6¼	3½
2	5¾	6¾	3¾
2½	6¼	7½	4¼
2¾	7¾	8¾	4¾
3	8½	—	5¾
3½	9½	—	6¾

Rod End Dimensions

Bore Size	Rod Dia (MM)	A	B -.001 to -.003	C	D	V	W	AB	IM Style 5	KK Styles 2,4&6	RD (Max.)	RT	VB	WB
1½	1	1½	1.500	½	7/8	½	1	—	7/8-14	¾-16	—	—	—	—
2	1	1½	1.500	½	7/8	¼	¾	¼-28	7/8-14	¾-16	2.472	.328	7/8	1¾
2	1¾	1¾	2.000	5/8	1½	¾	1	—	1¼-12	1-14	—	—	—	—
2½	1	1½	1.500	½	7/8	¼	¾	¼-28	7/8-14	¾-16	2.472	.328	7/8	1¾
2½	1¾	1¾	2.000	5/8	1½	¾	1	¼-28	1¼-12	1-14	2.972	.328	1	1¾
2½	1¾	2	2.375	¾	1½	½	1¼	¼-28	1½-12	1¼-12	3.470	.313	1½	1¾
3¼	1¾	1¾	2.000	5/8	1½	¼	7/8	¼-28	1¼-12	1-14	2.972	.328	1	1¾
3¼	1¾	2	2.375	¾	1½	¾	1½	¼-28	1½-12	1¼-12	3.470	.313	1½	1¾
3¼	2	2¼	2.625	7/8	1½	¾	1¼	¼-28	1¾-12	1½-12	3.720	.313	1½	2
4	1¾	2	2.375	¾	1½	¼	1	¼-28	1½-12	1¼-12	3.470	.313	1½	1¾
4	2	2¼	2.625	7/8	1½	¾	1½	¼-28	1¾-12	1½-12	3.720	.313	1½	2
4	2½	3	3.125	1	2½	¾	1¾	¼-28	2¼-12	1¾-12	4.252	.313	1¼	2¼
5	2	2¼	2.625	7/8	1½	¼	1½	¼-28	1¾-12	1½-12	3.720	.313	1½	2
5	2½	3	3.125	1	2½	¾	1¾	¼-28	2¼-12	1¾-12	4.252	.313	1¼	2¼
5	3	3½	3.750	1	2¾	¾	1¾	¼-28	2¾-12	2¼-12	4.752	.313	1¼	2¼
5	3½	3½	4.250	1	3	¾	1¾	¼-28	3¼-12	2½-12	5.252	.313	1¼	2¼
6	2½	3	3.125	1	2½	¼	1¼	¼-28	2¼-12	1¾-12	4.252	.313	1¼	2¼
6	3	3½	3.750	1	2¾	¼	1¼	¼-28	2¾-12	2¼-12	4.752	.313	1¼	2¼
6	3½	3½	4.250	1	3	¼	1¼	¼-28	3¼-12	2½-12	5.252	.313	1¼	2¼
6	4	4	4.750	1	3¾	¼	1¼	5/16-24	3¾-12	3-12	5.939	.610	1¼	2¼
7	3	3½	3.750	1	2¾	—	—	¼-28	2¾-12	2¼-12	4.752	.313	1¼	2¼
7	3½	3½	4.250	1	3	—	—	¼-28	3¼-12	2½-12	5.252	.313	1¼	2¼
7	4	4	4.750	1	3¾	—	—	5/16-24	3¾-12	3-12	5.939	.610	1¼	2¼
7	4½	4½	5.250	1	3¾	—	—	5/16-24	4¼-12	3¼-12	6.439	.610	1¼	2¼
7	5	5	5.750	1	4¼	—	—	5/16-24	4¾-12	3½-12	6.939	.610	1¼	2¼
8	3½	3½	4.250	1	3	—	—	¼-28	3¼-12	2½-12	5.252	.313	1¼	2¼
8	4	4	4.750	1	3¾	—	—	5/16-24	3¾-12	3-12	5.939	.610	1¼	2¼
8	4½	4½	5.250	1	3¾	—	—	5/16-24	4¼-12	3¼-12	6.439	.610	1¼	2¼
8	5	5	5.750	1	4¼	—	—	5/16-24	4¾-12	3½-12	6.939	.610	1¼	2¼
8	5½	5½	6.250	1	4¾	—	—	5/16-24	5¼-12	4-12	7.439	.610	1¼	2¼

Add Stroke

XC	ZC	ZJ
6¾	6¾	5¾
6¾	7¼	6
7¼	8	6
7½	8¼	6¼
7¾	8½	6½
7¾	8¾	6¾
7¾	8¾	6¾
8¾	9¾	7½
8¾	9¾	7¾
9	10	7½
9¾	11½	7¾
9¾	11¼	7¾
10½	11½	8
10½	12¼	8¼
10¾	12½	8½
10¾	12½	8½
10¾	12½	8½
12½	14½	9¾
12½	14½	9¾
12½	14½	9¾
12½	14½	9¾
13¾	16¼	10¾
13¾	16¼	10¾
13¾	16¼	10¾
13¾	16¼	10¾
13¾	16¼	10¾
15	17¾	11¾
15	17¾	11¾
15	17¾	11¾
15	17¾	11¾
15	17¾	11¾

Miller H Series Hydraulic Cylinders

Detachable Clevis 1 1/2" - 5" Bore Cylinders

Model 86-B (NFPA MP2)
Bolted Bushing
Detachable Clevis
(Pivot Pin Included)

Mounting Dimensions
(See tables on opposite page)

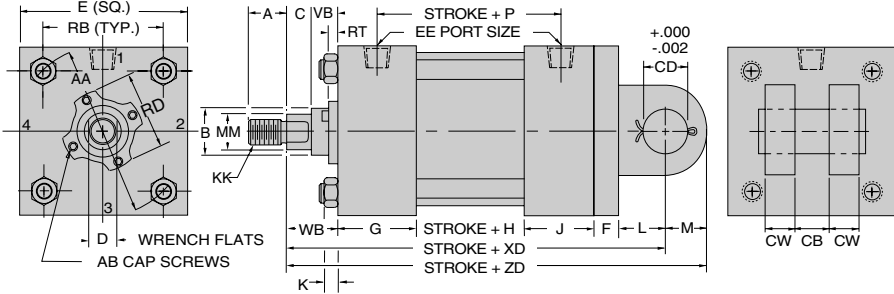
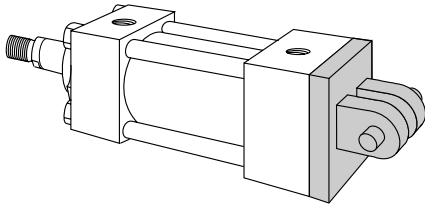

Model 86-R (NFPA MP2)
Square Retainer Held Bushing
Detachable Clevis
(Pivot Pin Included)

Mounting Dimensions
(See tables on opposite page)

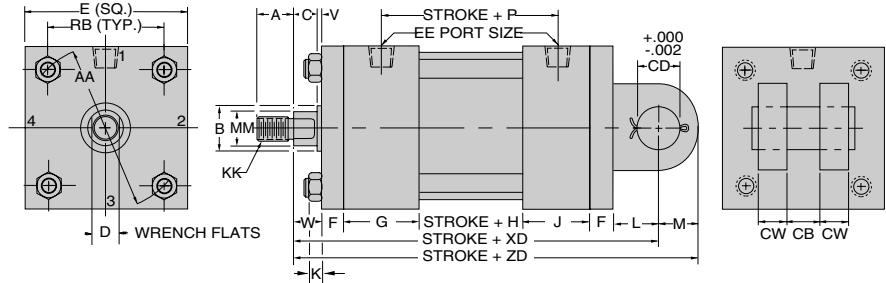
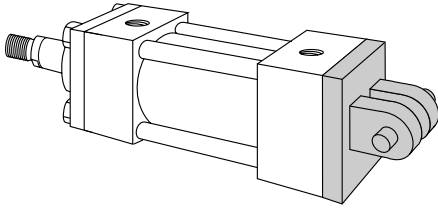

Common Rod End Styles & Dimensions

For additional standard rod ends, see "Rod End Styles and Dimensions" page.

Style No. 2-Standard
Threaded on Turndown Section

Style No. 4
Short Rod End-Internal Threads

Style No. 5
Threaded Intermediate Male

Style No. 6
Studded Rod End
(Available Thru 2" Rod Diameter)

"Special" Thread Style X
Special thread, extension, rod eye, blank, etc., are also available.

To order, specify "Style X" and give desired dimensions for KK, A, WB or W. If otherwise special, furnish dimensioned sketch.

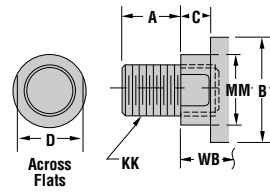
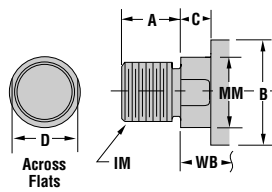
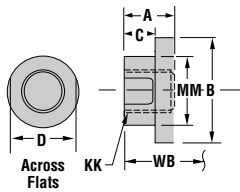
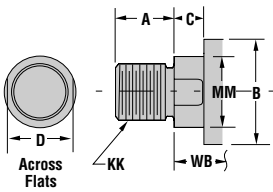

Miller H Series Hydraulic Cylinders

Detachable Clevis 1½"– 5" Bore Cylinders

Cylinder Body Dimensions

Bore Size	E	F	G	J	K	L	M	AA	CB	CD	CW	*EE		RB
												SAE	NPTF	
1½	2½	¾	1¾	1½	¾	¾	½	2.3	¾	½	½	-8	½	1.63
2	3	⅝	1¾	1½	7/16	1¼	¾	2.9	1¼	¾	⅝	-8	½	2.05
2½	3½	⅝	1¾	1½	7/16	1¼	¾	3.6	1¼	¾	⅝	-8	½	2.55
3¼	4½	¾	2	1¾	9/16	1½	1	4.6	1½	1	¾	-12	¾	3.25
4	5	7/8	2	1¾	9/16	2⅛	1⅜	5.4	2	1⅜	1	-12	¾	3.82
5	6½	7/8	2	1¾	13/16	2¼	1¾	7.0	2½	1¾	1¼	-12	¾	4.95

Add Stroke

H	P
1⅜	2⅞
1⅜	2⅞
1½	3
1¾	3½
2	3¾
2½	4¼

* SAE ports are standard, NPTF ports are available at no extra charge.

Rod End Dimensions

Bore Size	Rod Dia (MM)	A	B -.001 to -.003	C	D	V	W	AB	IM Style 5	KK Styles 2,4&6	RD (Max.)	RT	VB	WB
1½	⅝	¾	1.125	¾	½	¼	⅝	10-32	½-20	7/16-20	1.972	.316	⅝	1
	1	1⅛	1.500	½	7/8	½	1	—	7/8-14	¾-16	—	—	—	—
2	1	1⅛	1.500	½	7/8	¼	¾	¼-28	7/8-14	¾-16	2.472	.328	7/8	1⅜
	1⅜	1⅝	2.000	⅝	1⅛	¾	1	—	1¼-12	1-14	—	—	—	—
2½	1	1⅛	1.500	½	7/8	¼	¾	¼-28	7/8-14	¾-16	2.472	.328	7/8	1⅜
	1⅜	1⅝	2.000	⅝	1⅛	¾	1	¼-28	1¼-12	1-14	2.972	.328	1	1⅝
	1¾	2	2.375	¾	1½	½	1¼	¼-28	1½-12	1¼-12	3.470	.313	1⅛	1⅞
3¼	1⅜	1⅝	2.000	⅝	1⅛	¼	7/8	¼-28	1¼-12	1-14	2.972	.328	1	1⅝
	1¾	2	2.375	¾	1½	¾	1⅛	¼-28	1½-12	1¼-12	3.470	.313	1⅛	1⅞
	2	2¼	2.625	7/8	1⅞	¾	1¼	¼-28	1¾-12	1½-12	3.720	.313	1⅛	2
4	1¾	2	2.375	¾	1½	¼	1	¼-28	1½-12	1¼-12	3.470	.313	1⅛	1⅞
	2	2¼	2.625	7/8	1⅞	¼	1⅛	¼-28	1¾-12	1½-12	3.720	.313	1⅛	2
	2½	3	3.125	1	2¼	¾	1⅜	¼-28	2¼-12	1⅞-12	4.252	.313	1¼	2¼
5	2	2¼	2.625	7/8	1⅞	¼	1⅛	¼-28	1¾-12	1½-12	3.720	.313	1⅛	2
	2½	3	3.125	1	2¼	¾	1⅜	¼-28	2¼-12	1⅞-12	4.252	.313	1¼	2¼
	3	3½	3.750	1	2⅝	¾	1⅜	¼-28	2¾-12	2¼-12	4.752	.313	1¼	2¼
	3½	3½	4.250	1	3	¾	1⅜	¼-28	3¼-12	2½-12	5.252	.313	1¼	2¼

Add Stroke

XD	ZD
6¾	7¼
7⅞	7⅝
7⅞	8⅝
8⅞	8⅞
8	8¾
8¼	9
8½	9¼
9⅜	10⅜
9⅝	10⅝
9¾	10¾
10⅝	12
10¾	12⅞
11	12⅞
11⅜	13⅞
11⅝	13⅝
11⅝	13⅝

Miller H Series Hydraulic Cylinders

Rear Eye 1½" – 8" Bore Cylinders

Model 90-B (NFPA MP3) Bolted Bushing Rear Eye (Pivot Pin Included)

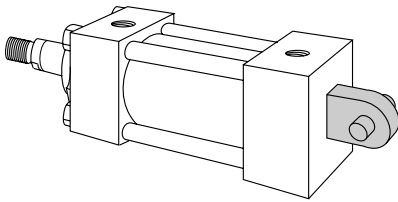

Mounting Dimensions (See tables on opposite page)

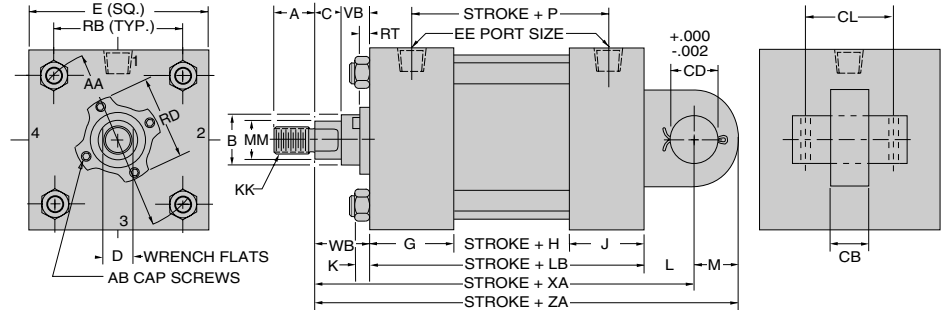

Model 90-R (NFPA MP3) Square Retainer Held Bushing Rear Eye (Pivot Pin Included)

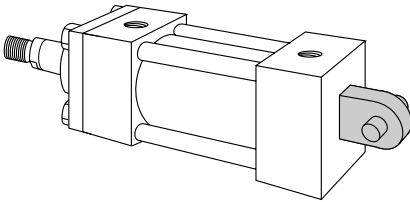

Mounting Dimensions (See tables on opposite page)

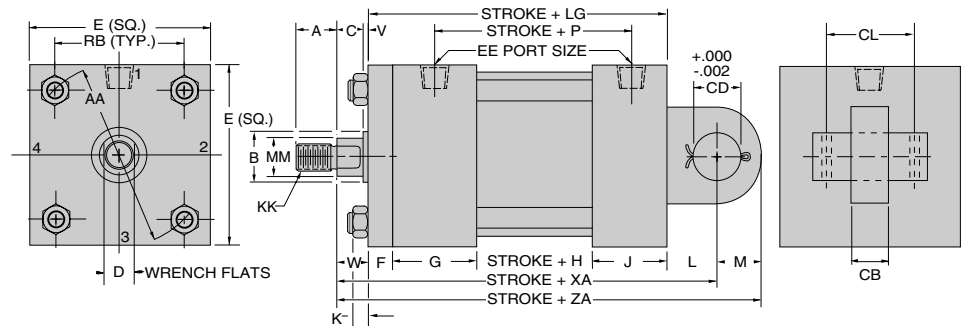

Common Rod End Styles & Dimensions

For additional standard rod ends, see "Rod End Styles and Dimensions" page.

Style No. 2-Standard Threaded on Turndown Section

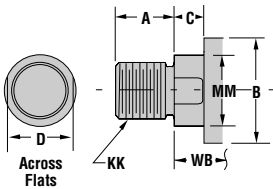

Style No. 4 Short Rod End-Internal Threads

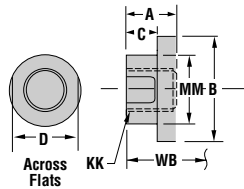

Style No. 5 Threaded Intermediate Male

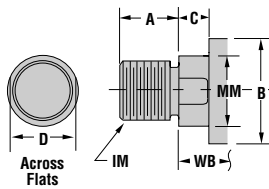

Style No. 6 Studded Rod End (Available Thru 2" Rod Diameter)

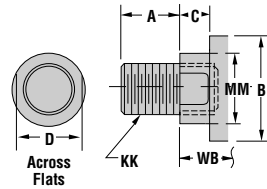

"Special" Thread Style X
Special thread, extension, rod eye, blank, etc., are also available.
To order, specify "Style X" and give desired dimensions for KK, A, WB or W. If otherwise special, furnish dimensioned sketch.

Miller H Series Hydraulic Cylinders

Rear Eye 1½"– 8" Bore Cylinders

Cylinder Body Dimensions

Bore Size	E	F	G	J	K	L	M	AA	CB	CD	CL	*EE		RB
												SAE	NPTF	
1½	2½	¾	1¾	1½	¾	¾	½	2.3	¾	½	1.83	-8	½	1.63
2	3	⅝	1¾	1½	7/16	1¼	¾	2.9	1¼	¾	2.58	-8	½	2.05
2½	3½	⅝	1¾	1½	7/16	1¼	¾	3.6	1¼	¾	2.58	-8	½	2.55
3¼	4½	¾	2	1¾	9/16	1½	1	4.6	1½	1	3.08	-12	¾	3.25
4	5	7/8	2	1¾	9/16	2½	1¾	5.4	2	1¾	4.08	-12	¾	3.82
5	6½	7/8	2	1¾	13/16	2¼	1¾	7.0	2½	1¾	5.08	-12	¾	4.95
6	7½	1	2¼	2¼	15/16	2½	2	8.1	2½	2	5.08	-16	1	5.73
7	8½	—	2¾	2¾	1	3	2½	9.3	3	2½	6.09	-20	1¼	6.58
8	9½	—	3	3	1¼	3¼	2¾	10.6	3	3	6.09	-24	1½	7.50

* SAE ports are standard, NPTF ports are available at no extra charge.

Add Stroke

H	LB	LG	P
1¾	4⅝	5	2⅞
1¾	4⅝	5¼	2⅞
1½	4¾	5⅜	3
1¾	5½	6¼	3½
2	5¾	6⅝	3¾
2½	6¼	7⅞	4¼
2⅞	7⅞	8⅜	4⅞
3	8½	—	5⅜
3½	9½	—	6⅞

Rod End Dimensions

Bore Size	Rod Dia (MM)	A	B -.001 to -.003	C	D	V	W	AB	IM Style 5	KK Styles 2,4&6	RD (Max.)	RT	VB	WB
1½	⅝	¾	1.125	¾	½	¼	⅝	10-32	½-20	7/16-20	1.972	.316	⅝	1
	1	1⅞	1.500	½	7/8	½	1	—	7/8-14	¾-16	—	—	—	—
2	1	1⅞	1.500	½	7/8	¼	¾	¼-28	7/8-14	¾-16	2.472	.328	7/8	1⅜
	1⅜	1⅝	2.000	⅝	1⅞	¾	1	—	1¼-12	1-14	—	—	—	—
2½	1	1⅞	1.500	½	7/8	¼	¾	¼-28	7/8-14	¾-16	2.472	.328	7/8	1⅜
	1⅜	1⅝	2.000	⅝	1⅞	¾	1	¼-28	1¼-12	1-14	2.972	.328	1	1⅝
3¼	1¾	2	2.375	¾	1½	½	1¼	¼-28	1½-12	1¼-12	3.470	.313	1⅞	1⅞
	1¾	2	2.375	¾	1½	¾	1⅞	¼-28	1½-12	1¼-12	3.470	.313	1⅞	1⅞
4	2	2¼	2.625	7/8	1⅞	¾	1¼	¼-28	1¾-12	1¼-12	3.720	.313	1⅞	2
	1¾	2	2.375	¾	1½	¼	1	¼-28	1½-12	1¼-12	3.470	.313	1⅞	1⅞
5	2	2¼	2.625	7/8	1⅞	¼	1⅞	¼-28	1¾-12	1½-12	3.720	.313	1⅞	2
	2½	3	3.125	1	2¼	¾	1¾	¼-28	2¼-12	1⅞-12	4.252	.313	1¼	2¼
6	2	2¼	2.625	7/8	1⅞	¼	1⅞	¼-28	1¾-12	1½-12	3.720	.313	1⅞	2
	2½	3	3.125	1	2¼	¾	1¾	¼-28	2¼-12	1⅞-12	4.252	.313	1¼	2¼
7	3	3½	3.750	1	2⅝	¾	1¾	¼-28	2¾-12	2¼-12	4.752	.313	1¼	2¼
	3½	3½	4.250	1	3	¾	1¾	¼-28	3¼-12	2½-12	5.252	.313	1¼	2¼
8	2½	3	3.125	1	2¼	¼	1¼	¼-28	2¼-12	1⅞-12	4.252	.313	1¼	2¼
	3	3½	3.750	1	2⅝	¼	1¼	¼-28	2¾-12	2¼-12	4.752	.313	1¼	2¼
9	3½	3½	4.250	1	3	¼	1¼	¼-28	3¼-12	2½-12	5.252	.313	1¼	2¼
	4	4	4.750	1	3⅜	¼	1¼	¼-28	3¾-12	3-12	5.939	.610	1¼	2¼
10	3	3½	3.750	1	2⅝	—	—	¼-28	2¾-12	2¼-12	4.752	.313	1¼	2¼
	3½	3½	4.250	1	3	—	—	¼-28	3¼-12	3-12	5.939	.610	1¼	2¼
11	4½	4½	5.250	1	3⅞	—	—	5/16-24	4¼-12	3¼-12	6.439	.610	1¼	2¼
	5	5	5.750	1	4¼	—	—	5/16-24	4¾-12	3½-12	6.939	.610	1¼	2¼
12	3½	3½	4.250	1	3	—	—	¼-28	3¼-12	2½-12	5.252	.313	1¼	2¼
	4	4	4.750	1	3⅜	—	—	5/16-24	3¾-12	3-12	5.939	.610	1¼	2¼
13	4½	4½	5.250	1	3⅞	—	—	5/16-24	4¼-12	3¼-12	6.439	.610	1¼	2¼
	5	5	5.750	1	4¼	—	—	5/16-24	4¾-12	3½-12	6.939	.610	1¼	2¼
14	5½	5½	6.250	1	4⅝	—	—	5/16-24	5¼-12	4-12	7.439	.610	1¼	2¼

Add Stroke

XA	ZA
6⅜	6⅞
6¾	7¼
7¼	8
7½	8¼
7⅞	8⅞
7⅞	8⅞
8⅝	9⅝
8⅞	9⅞
9	10
9¾	11⅞
9⅞	11¼
10⅞	11½
10½	12¼
10¾	12½
10¾	12½
10¾	12½
12⅞	14⅞
12⅞	14⅞
12⅞	14⅞
12⅞	14⅞
13¾	16¼
13¾	16¼
13¾	16¼
13¾	16¼
15	17¾
15	17¾
15	17¾
15	17¾

Miller H Series Hydraulic Cylinders

Rear Eye Spherical Bearing 1½"–6" Bore Cylinders

Model 94-B Bolted Bushing Rear Eye Spherical Bearing (Pivot Pin Included)

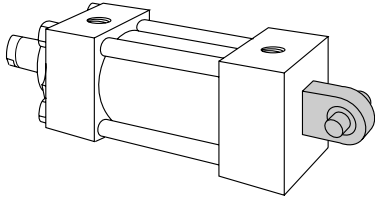

Mounting Dimensions (See tables on opposite page)

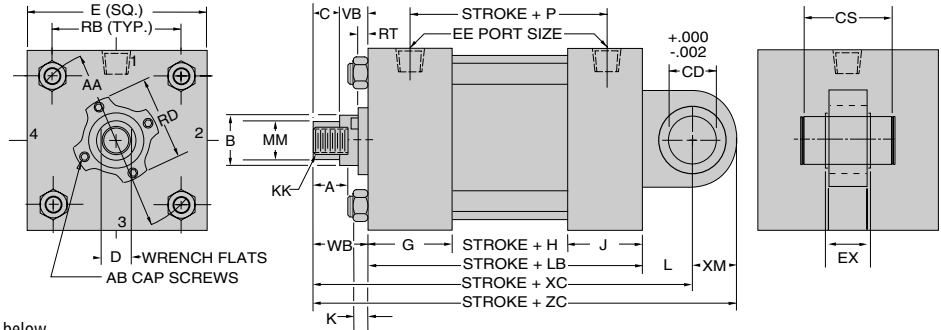

Note: See next page for pivot pin dimensions.
Model 94 should use Spherical Rod Eye on Rod End. See below.
See Maximum Cylinder Pressure Rating below.

Model 94-R Square Retainer Held Bushing Rear Eye Spherical Bearing (Pivot Pin Included)

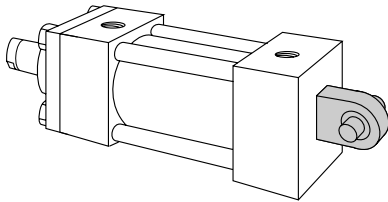

Mounting Dimensions (See tables on opposite page)

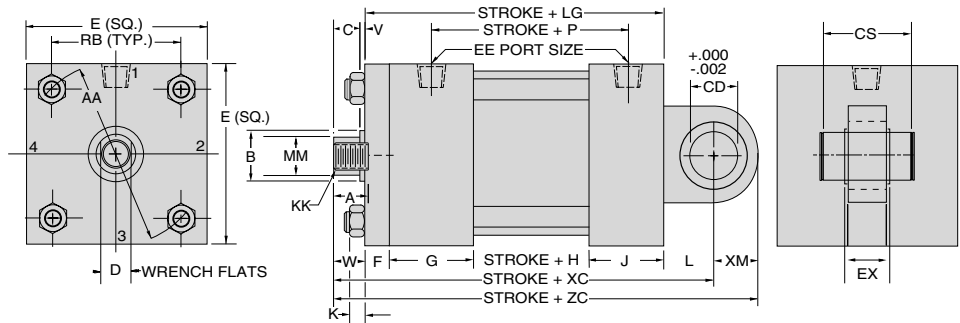

Note: See next page for pivot pin dimensions.
Model 94 should use Spherical Rod Eye on Rod End. See below.
See Maximum Cylinder Pressure Rating below.

Maximum Cylinder Pressure Rating

Bore	Max Press (psi)
1½	1520
2	2200
2½	1450
3¼	1500
4	1850
5	2000
6	1800

Rod End Style

For additional standard rod ends, see "Rod End Styles and Dimensions" page.

Style No. 4 Short Rod End-Internal Threads

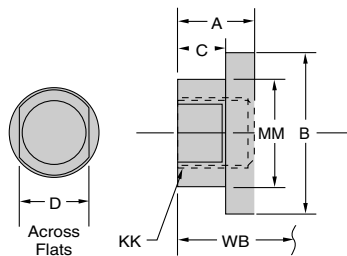

"Special" Thread Style X

Special thread, extension, rod eye, blank, etc., are also available.

To order, specify "Style X" and give desired dimensions for KK, A, WB or W. If otherwise special, furnish dimensioned sketch.

Miller H Series Hydraulic Cylinders

Rear Eye Spherical Bearing 1½"– 6" Bore Cylinders

Cylinder Body Dimensions

Bore	E Size	F	G	J	K	L	XM	AA	EX	CD	CS	*EE		RB
												SAE	NPTF	
1½	2½	¾	1¾	1½	¾	¾	¾	2.3	7/16	½	19/16	-8	½	1.63
2	3	5/8	1¾	1½	7/16	1¼	1	2.9	21/32	¾	21/32	-8	½	2.05
2½	3½	5/8	1¾	1½	7/16	1¼	1	3.6	21/32	¾	21/32	-8	½	2.55
3¼	4½	¾	2	1¾	9/16	1½	1¼	4.6	7/8	1	2½	-12	¾	3.25
4	5	7/8	2	1¾	9/16	2½	1½	5.4	13/16	1¾	35/16	-12	¾	3.82
5	6½	7/8	2	1¾	13/16	2¼	2½	7.0	17/32	1¾	47/32	-12	¾	4.95
6	7½	1	2¼	2¼	15/16	2½	2½	8.1	1¾	2	415/16	-16	1	5.73

* SAE ports are standard, NPTF ports are available at no extra charge.

Add Stroke

H	LB	LG	P
1¾	45/8	5	27/8
1¾	45/8	5¼	27/8
1½	4¾	53/8	3
1¾	5½	6¼	3½
2	5¾	65/8	3¾
2½	6¼	7½	4¼
27/8	73/8	83/8	47/8

Rod End Dimensions

Bore Size	Rod Dia (MM)	A	B -.001 to -.003	C	D	V	W	AB	KK Styles 4	RD (Max.)	RT	VB	WB
1½	¾	¾	1.125	¾	½	¼	5/8	10-32	7/16-20	1.972	.316	5/8	1
	1	11/8	1.500	½	7/8	½	1	—	¾-16	—	—	—	—
2	1	11/8	1.500	½	7/8	¼	¾	¼-28	-16	2.472	.328	7/8	1¾
	1¾	15/8	2.000	5/8	11/8	¾	1	—	1-14	—	—	—	—
2½	1	11/8	1.500	½	7/8	¼	¾	¼-28	¾-16	2.472	.328	7/8	1¾
	1¾	15/8	2.000	5/8	11/8	¾	1	¼-28	1-14	2.972	.328	1	15/8
	1¾	2	2.375	¾	1½	½	1¼	¼-28	1¼-12	3.470	.313	11/8	17/8
3¼	1¾	15/8	2.000	5/8	11/8	¼	7/8	¼-28	1-14	2.972	.328	1	15/8
	1¾	2	2.375	¾	1½	¾	11/8	¼-28	1¼-12	3.470	.313	11/8	17/8
4	2	2¼	2.625	7/8	111/16	¾	1¼	¼-28	1½-12	3.720	.313	11/8	2
	1¾	2	2.375	¾	1½	¼	1	¼-28	1¼-12	3.470	.313	11/8	17/8
	2	2¼	2.625	7/8	111/16	¼	11/8	¼-28	1½-12	3.720	.313	11/8	2
5	2½	3	3.125	1	21/16	¾	1¾	¼-28	17/8-12	4.252	.313	1¼	2¼
	2	2¼	2.625	7/8	111/16	¼	11/8	¼-28	1½-12	3.720	.313	11/8	2
	2½	3	3.125	1	21/16	¾	1¾	¼-28	17/8-12	4.252	.313	1¼	2¼
	3	3½	3.750	1	25/8	¾	1¾	¼-28	2¼-12	4.752	.313	1¼	2¼
6	3½	3½	4.250	1	3	¾	1¾	¼-28	2½-12	5.252	.313	1¼	2¼
	2½	3	3.125	1	21/16	¼	1¼	¼-28	17/8-12	4.252	.313	1¼	2¼
	3	3½	3.750	1	25/8	¼	1¼	¼-28	2¼-12	4.752	.313	1¼	2¼
	3½	3½	4.250	1	3	¼	1¼	¼-28	2½-12	5.252	.313	1¼	2¼
6	4	4	4.750	1	33/8	¼	1¼	5/16-24	3-12	5.939	.610	1¼	2¼

Add Stroke

XC	ZC
63/8	71/8
6¾	7½
7¼	8¼
7½	8½
7¾	83/8
75/8	85/8
77/8	87/8
83/8	93/8
87/8	101/8
9	10¼
9¾	115/8
97/8	11¾
101/8	12
10½	13
10¾	13¼
10¾	13¼
10¾	13¼
121/8	145/8
121/8	145/8
121/8	145/8
121/8	145/8

Miller H Series Hydraulic Cylinders

Spherical Rod Eye

Spherical Rod Eye

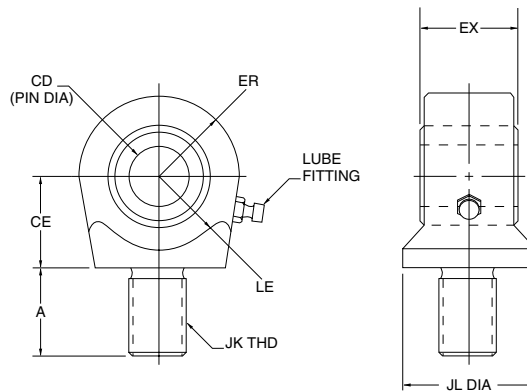

Part No.	CD ± . ⁰⁰⁰⁰ / ₀₀₀₅	A	CE	EX	ER	LE	JK	JL	MAX. LOAD CAPACITY(lbs)
057-SRE02-44-20	.5000	1 ¹ / ₁₆	7 ⁷ / ₈	7 ⁷ / ₁₆	1 ³ / ₁₆	3 ³ / ₄	7 ⁷ / ₁₆ -20	7 ⁷ / ₈	2,644
057-SRE02-75-16	.7500	1	1 ¹ / ₄	2 ¹ / ₃₂	1 ¹ / ₈	1 ¹ / ₁₆	3 ³ / ₄ -16	1 ⁵ / ₁₆	9,441
057-SRE02-100-14	1.0000	1 ¹ / ₂	1 ⁷ / ₈	7 ⁷ / ₈	1 ¹ / ₄	1 ⁷ / ₁₆	1-14	1 ¹ / ₂	16,860
057-SRE02-125-12	1.3750	2	2 ¹ / ₈	1 ³ / ₁₆	1 ¹¹ / ₁₆	1 ⁷ / ₈	1 ¹ / ₄ -12	2	28,562
057-SRE02-150-12	1.7500	2 ¹ / ₈	2 ¹ / ₂	1 ¹⁷ / ₃₂	2 ¹ / ₁₆	2 ¹ / ₈	1 ¹ / ₂ -12	2 ¹ / ₄	43,005
057-SRE02-188-12	2.0000	2 ⁷ / ₈	2 ³ / ₄	1 ³ / ₄	2 ¹ / ₂	2 ¹ / ₂	1 ⁷ / ₈ -12	2 ³ / ₄	70,193

Clevis Bracket for Spherical Eye

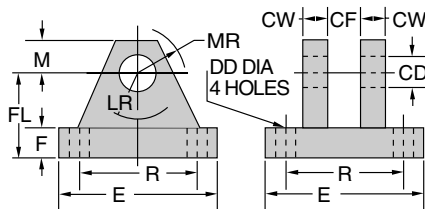

Part No.	057-SMB01 50	057-SMB01 75	057-SMB01 100	057-SMB01 138	057-SMB01 175	057-SMB01 200
CD	1 ¹ / ₂	3 ³ / ₄	1	1 ³ / ₈	1 ³ / ₄	2
CF	7 ⁷ / ₁₆	2 ¹ / ₃₂	7 ⁷ / ₈	1 ³ / ₁₆	1 ¹⁷ / ₃₂	1 ³ / ₄
CW	1 ¹ / ₂	5 ⁵ / ₈	3 ³ / ₄	1	1 ¹ / ₄	1 ¹ / ₂
DD	1 ³ / ₃₂	1 ⁷ / ₃₂	1 ⁷ / ₃₂	2 ¹ / ₃₂	2 ⁹ / ₃₂	2 ⁹ / ₃₂
E	3	3 ³ / ₄	5 ¹ / ₂	6 ¹ / ₂	8 ¹ / ₂	10 ⁵ / ₈
F	1 ¹ / ₂	5 ⁵ / ₈	3 ³ / ₄	7 ⁷ / ₈	1 ¹ / ₄	1 ¹ / ₂
FL	1 ¹ / ₂	2	2 ¹ / ₂	3 ¹ / ₂	4 ¹ / ₂	5
LR	1 ⁵ / ₁₆	1 ³ / ₈	1 ¹¹ / ₁₆	2 ⁷ / ₁₆	2 ⁷ / ₈	3 ⁵ / ₁₆
M	1 ¹ / ₂	7 ⁷ / ₈	1	1 ³ / ₈	1 ³ / ₄	2
MR	5 ⁵ / ₈	1	1 ³ / ₁₆	1 ³ / ₄	2 ¹ / ₁₆	2 ³ / ₈
R	2.05	2.76	4.10	4.95	6.58	7.92
Load Capacity	5,770	9,450	14,300	20,322	37,800	50,375

Pivot Pin for Spherical Eye

(Includes 2 Retainer Rings)

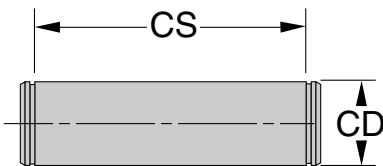

Part No.	057-PP005 -050	057-PP005 -075	057-PP005 -100	057-PP005 -138	057-PP005 -175	057-PP005 -200
CD	.4997 - .0004	.7497 - .0005	.9997 - .0005	1.3746 - .0006	1.7496 - .0006	1.9996 - .0007
CS	1 ⁹ / ₁₆	2 ¹ / ₃₂	2 ¹ / ₂	3 ⁵ / ₁₆	4 ⁷ / ₃₂	4 ¹⁵ / ₁₆
Load (lb) Capacity	8,600	19,300	34,300	65,000	105,200	137,400

Note: Maximum Cylinder Pressure Ratings for Model 94 Cylinders are shown on previous page. Load capacities of accessories or Model 94 cylinders at Maximum Pressure Ratings should not be exceeded.

Miller H Series Hydraulic Cylinders

Double Rod End

Bolted Bushing Double Rod End

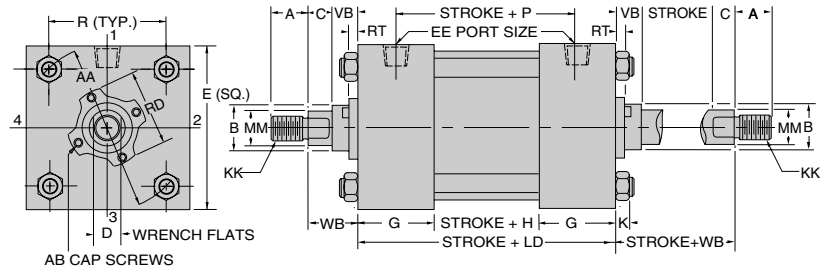
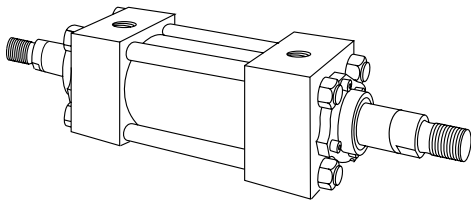

Note: To determine the dimensions for your Double Rod End cylinder:

- Refer to the Single Rod mounting style you are selecting on the preceding pages.
- Select the necessary dimensions which pertain to your mounting style.
- Return to this page and use these dimensions to finish sizing your cylinder.

Note: Double Rod End cylinders have head (G dimensions) at both ends and LD replaces the LB dimension. On Double Rod End cylinders where the rod end styles differ, be sure to clearly state which rod end is on which cylinder end. (port position 1 is standard).

Square Retainer Held Bushing Double Rod End

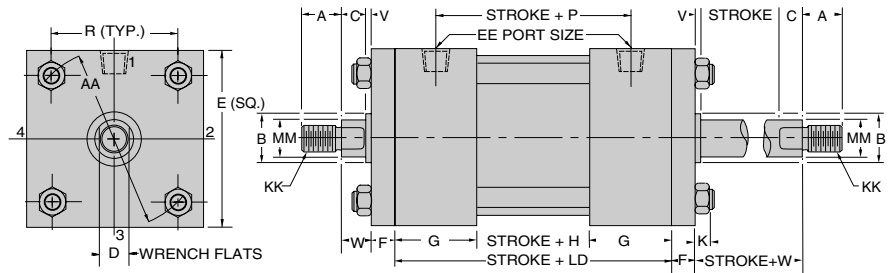
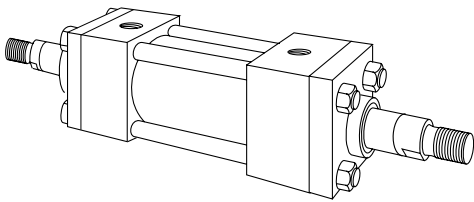

Note: To determine the dimensions for your Double Rod End cylinder:

- Refer to the Single Rod mounting style you are selecting on the preceding pages.
- Select the necessary dimensions which pertain to your mounting style.
- Return to this page and use these dimensions to finish sizing your cylinder.

Note: Double Rod End cylinders have head (G dimensions) at both ends and LD replaces the LB dimension. On Double Rod End cylinders where the rod end styles differ, be sure to clearly state which rod end is on which cylinder end. (port position 1 is standard).

Common Rod End Styles & Dimensions

For additional standard rod ends, see "Rod End Styles and Dimensions" page.

Style No. 2-Standard Threaded on Turndown Section

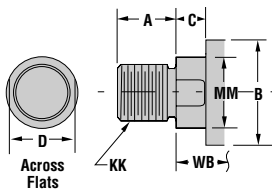

Style No. 4 Short Rod End-Internal Threads

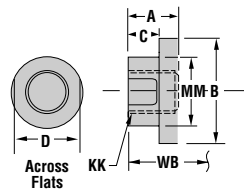

Style No. 5 Threaded Intermediate Male

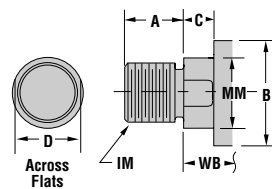

Style No. 6 Studded Rod End (Available Thru 2" Rod Diameter)

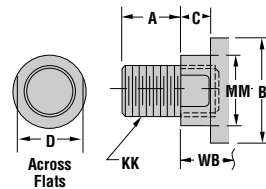

"Special" Thread Style X
Special thread, extension, rod eye, blank, etc., are also available.
To order, specify "Style X" and give desired dimensions for KK, A, WB or W. If otherwise special, furnish dimensioned sketch.

Miller H Series Hydraulic Cylinders

No Mounting
10"–20" Bore Cylinders

Model 50-B Bolted Bushing

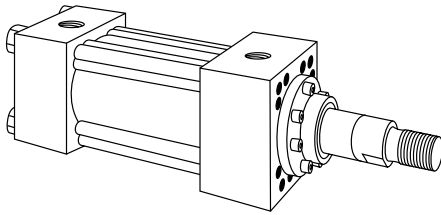

Model 50-B No Tie Rods Extended.

Mounting Dimensions (see tables on opposite page)

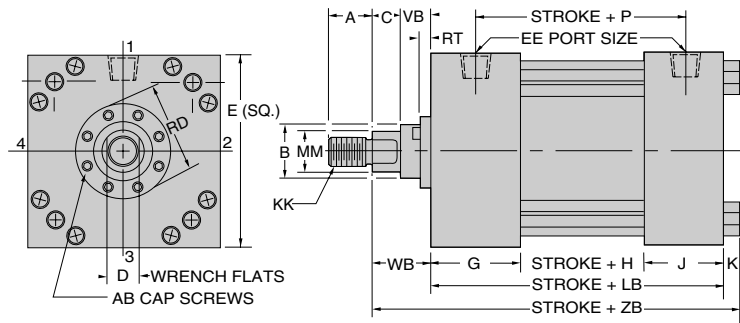

Tie Rod Construction For 10" - 20" Bore Cylinders

BORE SIZE	10	12	14	16	18	20
NO. TIE RODS PER CORNER	3	4	5	7	6	7

Bolted Bushing Double Rod End Model DH-50B

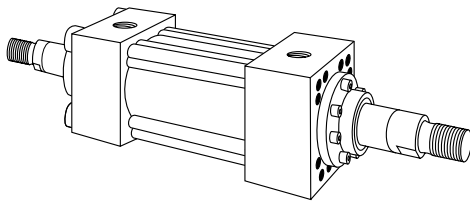

Note: To determine the dimensions for your Double Rod End cylinder:

- Refer to the Single Rod mounting style you are selecting on the following pages.
- Select the necessary dimensions which pertain to your mounting style.
- Return to this page and use these dimensions to finish sizing your cylinder.

Mounting Dimensions (see tables on opposite page)

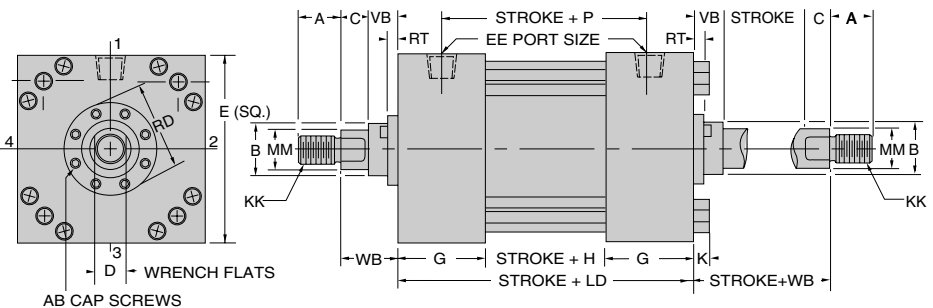

Note: Double Rod End cylinders have had (G dimensions) at both ends and LD replaces the LB dimension. On Double Rod End cylinders where the rod end styles differ, be sure to clearly state which rod is on which cylinder end. (port position 1 is standard).

Common Rod End Styles & Dimensions

For additional standard rod ends, see "Rod End Styles and Dimensions" page.

Style No. 2-Standard Threaded on Turndown Section

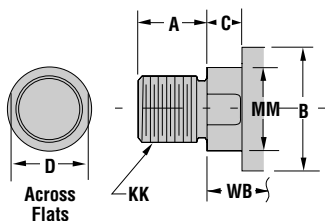

Style No. 4 Short Rod End-Internal Threads

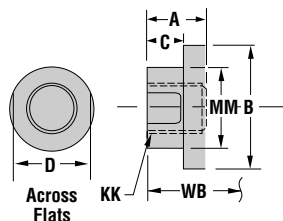

Style No. 5 Threaded Intermediate Male

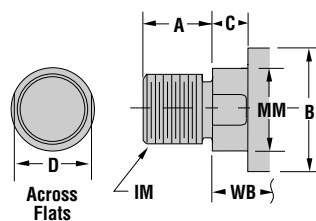

Miller H Series Hydraulic Cylinders

No Mounting 10"-20" Bore Cylinders

Cylinder Body Dimensions

Bore Size	E	G	J	K	AA	*EE	
						SAE	NPTF
10	12 ⁵ / ₈	3 ¹¹ / ₁₆	3 ¹¹ / ₁₆	1 ¹ / ₂	12.69	-32	2
12	15 ¹ / ₈	4 ⁷ / ₁₆	4 ⁷ / ₁₆	1 ¹ / ₂	15.06	-32	2 ¹ / ₂
14	17 ¹ / ₂	4 ⁷ / ₈	4 ⁷ / ₈	1 ¹ / ₂	17.31	-32	3
16	20 ¹ / ₂	5 ⁷ / ₈	5 ⁷ / ₈	1 ¹ / ₂	19.75	-32	4
18	23	6 ³ / ₈	6 ³ / ₈	1 ¹³ / ₁₆	22.25	-32	4
20	25 ¹ / ₂	7 ³ / ₈	7 ³ / ₈	1 ¹³ / ₁₆	24.50	-32	5

*SAE ports are standard, NPTF ports are available at no extra charge.

Add Stroke

H	LB	LD	P
4 ³ / ₄	12 ¹ / ₈	12 ¹ / ₈	8
5 ⁵ / ₈	14 ¹ / ₂	14 ¹ / ₂	9 ³ / ₈
5 ⁷ / ₈	15 ⁵ / ₈	15 ⁵ / ₈	10 ³ / ₈
6 ⁷ / ₈	18 ⁵ / ₈	18 ⁵ / ₈	12 ³ / ₄
8 ¹ / ₄	21	21	14 ¹ / ₄
9 ¹ / ₄	24	24	16

Rod End Dimensions

Bore Size	Rod Dia	A	B -.001 to -.003	C	D	AB	KK	RD	RT MAX.	VB	WB
10"	4 ¹ / ₂ "	4 ¹ / ₂	5.250	1 ¹¹ / ₁₆ *	3 ⁷ / ₈	5 ¹ / ₁₆ -24	3 ¹ / ₄ -12	6.439	.610	1 ¹ / ₄	2 ¹⁵ / ₁₆
	5"	5	5.750	1 ¹⁵ / ₁₆ *	4 ¹ / ₄	5 ¹ / ₁₆ -24	3 ¹ / ₂ -12	6.939	.610	1 ¹ / ₄	3 ³ / ₁₆
	5 ¹ / ₂ "	5 ¹ / ₂	6.250	1 ¹⁵ / ₁₆ *	4 ⁵ / ₈	5 ¹ / ₁₆ -24	4-12	7.439	.610	1 ¹ / ₄	3 ³ / ₁₆
	7"	7	7.750	1	6 ¹ / ₈	5 ¹ / ₁₆ -24	5 ¹ / ₂ -12	8.939	.610	2 ⁷ / ₁₆	3 ⁷ / ₁₆
12"	5 ¹ / ₂ "	5 ¹ / ₂	6.250	1 ¹⁵ / ₁₆ *	4 ⁵ / ₈	5 ¹ / ₁₆ -24	4-12	7.439	.610	1 ¹ / ₄	3 ³ / ₁₆
	7"	7	7.750	1	6 ¹ / ₈	5 ¹ / ₁₆ -24	5 ¹ / ₂ -12	8.939	.610	2 ⁷ / ₁₆	3 ⁷ / ₁₆
	8"	8	8.750	1	6 ⁷ / ₈	5 ¹ / ₁₆ -24	5 ³ / ₄ -8	9.939	.610	2 ⁷ / ₁₆	3 ⁷ / ₁₆
14"	7"	7	7.750	1	6 ¹ / ₈	5 ¹ / ₁₆ -24	5 ¹ / ₂ -12	8.939	.610	2 ⁷ / ₁₆	3 ⁷ / ₁₆
	8"	8	8.750	1	6 ⁷ / ₈	5 ¹ / ₁₆ -24	5 ³ / ₄ -8	9.939	.610	2 ⁷ / ₁₆	3 ⁷ / ₁₆
	9"	9	9.750	1	7 ⁷ / ₈	5 ¹ / ₁₆ -24	6 ¹ / ₂ -8	10.939	.610	2 ⁷ / ₁₆	3 ⁷ / ₁₆
	10"	10	10.750	1	8 ⁵ / ₈	5 ¹ / ₁₆ -24	7-8	11.939	.610	2 ⁷ / ₁₆	3 ⁷ / ₁₆
16"	8"	8	8.750	1	6 ⁷ / ₈	5 ¹ / ₁₆ -24	5 ³ / ₄ -8	9.939	.610	2 ⁷ / ₁₆	3 ⁷ / ₁₆
	9"	9	9.750	1	7 ⁷ / ₈	5 ¹ / ₁₆ -24	6 ¹ / ₂ -8	10.939	.610	2 ⁷ / ₁₆	3 ⁷ / ₁₆
	10"	10	10.750	1	8 ⁵ / ₈	5 ¹ / ₁₆ -24	7-8	11.939	.610	2 ⁷ / ₁₆	3 ⁷ / ₁₆
18"	9"	9	9.750	1	7 ⁷ / ₈	5 ¹ / ₁₆ -24	6 ¹ / ₂ -8	10.939	.610	2 ⁷ / ₁₆	3 ⁷ / ₁₆
	10"	10	10.750	1	8 ⁵ / ₈	5 ¹ / ₁₆ -24	7-8	11.939	.610	2 ⁷ / ₁₆	3 ⁷ / ₁₆
20"	10"	10	10.750	1	8 ⁵ / ₈	5 ¹ / ₁₆ -24	7-8	11.939	.610	2 ⁷ / ₁₆	3 ⁷ / ₁₆

*Wrench flats are 1" long these sizes

Add Stroke

ZB
16 ⁹ / ₁₆
16 ¹³ / ₁₆
16 ¹³ / ₁₆
17 ¹ / ₁₆
19 ³ / ₁₆
19 ⁷ / ₁₆
19 ⁷ / ₁₆
20 ⁹ / ₁₆
20 ⁹ / ₁₆
20 ⁹ / ₁₆
20 ⁹ / ₁₆
23 ⁹ / ₁₆
23 ⁹ / ₁₆
23 ⁹ / ₁₆
26 ¹ / ₄
26 ¹ / ₄
29 ¹ / ₄

Miller H Series Hydraulic Cylinders

Square Head/Cap 10"–20" Bore Cylinders

Model 63-B Bolted Bushing Square Head

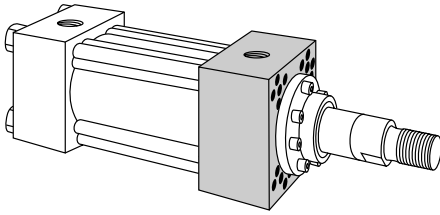

Mounting Dimensions (see tables on opposite page)

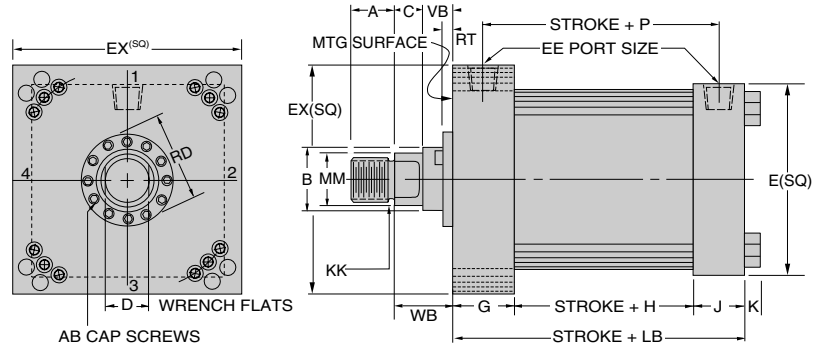

See Chart below for mounting hole locations

Model 64-B Bolted Bushing Square Cap

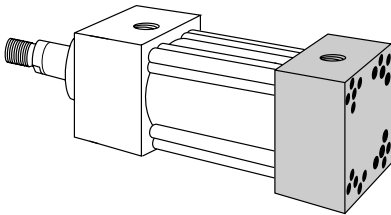

Mounting Dimensions (see tables on opposite page)

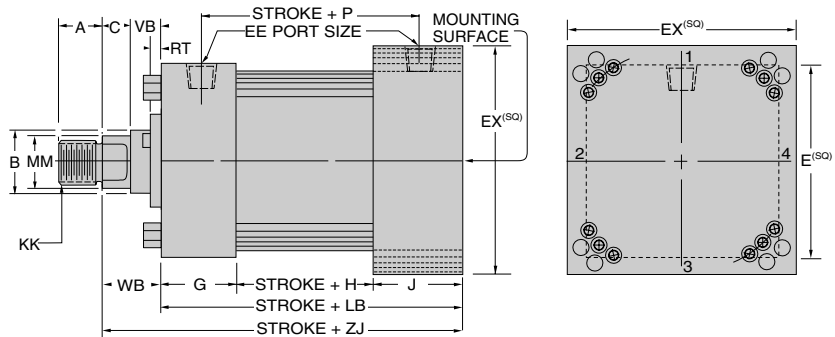

See Chart below for mounting hole locations

Model 63/64 Multiple Mounting Holes

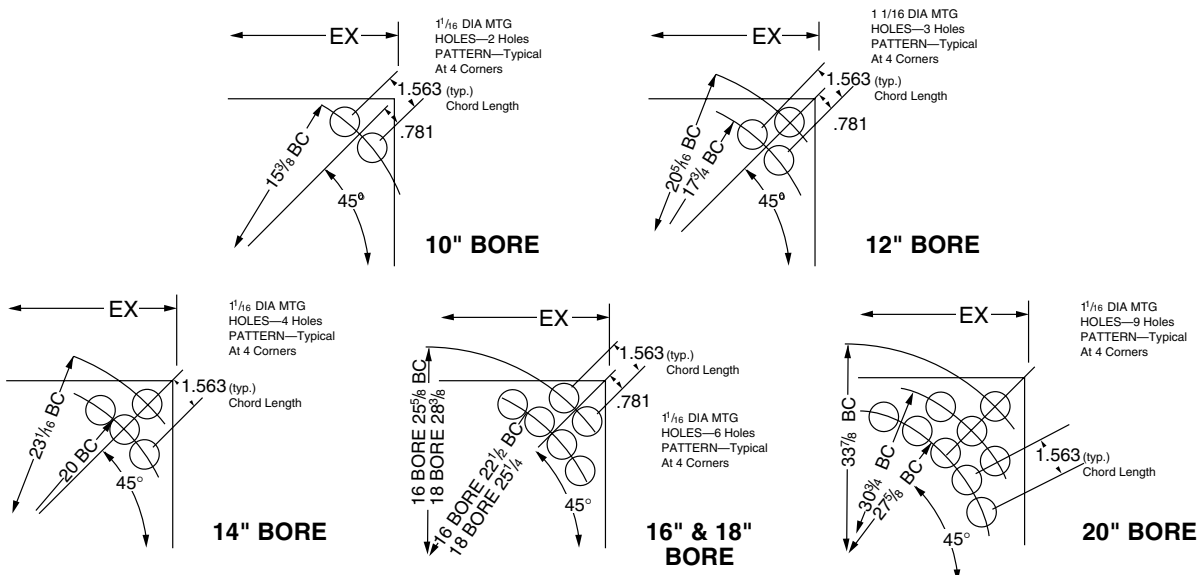

Note: Mount on outside face with high tensile socket head cap screws. Hardened 1/4" thick bearing plates are furnished with cylinder and must be used under bolt head.

Miller H Series Hydraulic Cylinders

Square Head/Cap 10"-20" Bore Cylinders

Cylinder Body Dimensions

Bore Size	E	G	J	K	*EE		EX
					SAE	NPTF	
10	12 ⁵ / ₈	3 ¹ / ₁₆	3 ¹ / ₁₆	1 ¹ / ₂	-32	2	13 ¹ / ₂
12	15 ¹ / ₈	4 ⁷ / ₁₆	4 ⁷ / ₁₆	1 ¹ / ₂	-32	2 ¹ / ₂	16
14	17 ¹ / ₂	4 ⁷ / ₈	4 ⁷ / ₈	1 ¹ / ₂	-32	3	17 ⁷ / ₈
16	20 ¹ / ₂	5 ⁷ / ₈	5 ⁷ / ₈	1 ¹ / ₂	-32	4	20 ¹ / ₂
18	23	6 ³ / ₈	6 ³ / ₈	1 ¹³ / ₁₆	-32	4	23
20	25 ¹ / ₂	7 ³ / ₈	7 ³ / ₈	1 ¹³ / ₁₆	-32	5	25 ¹ / ₂

Add Stroke

H	LB	P
4 ³ / ₄	12 ¹ / ₈	8
5 ⁵ / ₈	14 ¹ / ₂	9 ³ / ₈
5 ⁷ / ₈	15 ⁵ / ₈	10 ³ / ₈
6 ⁷ / ₈	18 ⁵ / ₈	12 ³ / ₄
8 ¹ / ₄	21	14 ¹ / ₄
9 ¹ / ₄	24	16

*SAE ports are standard, NPTF ports are available at no extra charge.

Rod End Dimensions

Bore Size	Rod Dia	A	B -.001 to -.003	C	D	AB	KK	RD	RT MAX.	VB	WB
10"	4 ¹ / ₂ "	4 ¹ / ₂	5.250	1 ¹ / ₁₆ "*	3 ⁷ / ₈	5 ¹ / ₁₆ -24	3 ¹ / ₄ -12	6.439	.610	1 ¹ / ₄	2 ¹⁵ / ₁₆
	5"	5	5.750	1 ¹⁵ / ₁₆ "*	4 ¹ / ₄	5 ¹ / ₁₆ -24	3 ¹ / ₂ -12	6.939	.610	1 ¹ / ₄	3 ³ / ₁₆
	5 ¹ / ₂ "	5 ¹ / ₂	6.250	1 ¹⁵ / ₁₆ "*	4 ⁵ / ₈	5 ¹ / ₁₆ -24	4-12	7.439	.610	1 ¹ / ₄	3 ³ / ₁₆
	7"	7	7.750	1	6 ¹ / ₈	5 ¹ / ₁₆ -24	5 ¹ / ₂ -12	8.939	.610	2 ⁷ / ₁₆	3 ⁷ / ₁₆
12"	5 ¹ / ₂ "	5 ¹ / ₂	6.250	1 ¹⁵ / ₁₆ "*	4 ⁵ / ₈	5 ¹ / ₁₆ -24	4-12	7.439	.610	1 ¹ / ₄	3 ³ / ₁₆
	7"	7	7.750	1	6 ¹ / ₈	5 ¹ / ₁₆ -24	5 ¹ / ₂ -12	8.939	.610	2 ⁷ / ₁₆	3 ⁷ / ₁₆
	8"	8	8.750	1	6 ⁷ / ₈	5 ¹ / ₁₆ -24	5 ³ / ₄ -8	9.939	.610	2 ⁷ / ₁₆	3 ⁷ / ₁₆
14"	7"	7	7.750	1	6 ¹ / ₈	5 ¹ / ₁₆ -24	5 ¹ / ₂ -12	8.939	.610	2 ⁷ / ₁₆	3 ⁷ / ₁₆
	8"	8	8.750	1	6 ⁷ / ₈	5 ¹ / ₁₆ -24	5 ³ / ₄ -8	9.939	.610	2 ⁷ / ₁₆	3 ⁷ / ₁₆
	9"	9	9.750	1	7 ⁷ / ₈	5 ¹ / ₁₆ -24	6 ¹ / ₂ -8	10.939	.610	2 ⁷ / ₁₆	3 ⁷ / ₁₆
	10"	10	10.750	1	8 ⁵ / ₈	5 ¹ / ₁₆ -24	7-8	11.939	.610	2 ⁷ / ₁₆	3 ⁷ / ₁₆
16"	8"	8	8.750	1	6 ⁷ / ₈	5 ¹ / ₁₆ -24	5 ³ / ₄ -8	9.939	.610	2 ⁷ / ₁₆	3 ⁷ / ₁₆
	9"	9	9.750	1	7 ⁷ / ₈	5 ¹ / ₁₆ -24	6 ¹ / ₂ -8	10.939	.610	2 ⁷ / ₁₆	3 ⁷ / ₁₆
	10"	10	10.750	1	8 ⁵ / ₈	5 ¹ / ₁₆ -24	7-8	11.939	.610	2 ⁷ / ₁₆	3 ⁷ / ₁₆
18"	9"	9	9.750	1	7 ⁷ / ₈	5 ¹ / ₁₆ -24	6 ¹ / ₂ -8	10.939	.610	2 ⁷ / ₁₆	3 ⁷ / ₁₆
	10"	10	10.750	1	8 ⁵ / ₈	5 ¹ / ₁₆ -24	7-8	11.939	.610	2 ⁷ / ₁₆	3 ⁷ / ₁₆
20"	10"	10	10.750	1	8 ⁵ / ₈	5 ¹ / ₁₆ -24	7-8	11.939	.610	2 ⁷ / ₁₆	3 ⁷ / ₁₆

Add Stroke

ZJ
15 ¹ / ₁₆
15 ⁵ / ₁₆
15 ⁵ / ₁₆
15 ⁹ / ₁₆
17 ¹¹ / ₁₆
17 ¹⁵ / ₁₆
17 ¹⁵ / ₁₆
19 ¹ / ₁₆
19 ¹ / ₁₆
19 ¹ / ₁₆
19 ¹ / ₁₆
22 ¹ / ₁₆
22 ¹ / ₁₆
22 ¹ / ₁₆
24 ⁷ / ₁₆
24 ⁷ / ₁₆
27 ⁷ / ₁₆

*Wrench flats are 1" long these sizes

Common Rod End Styles & Dimensions

For additional standard rod ends, see "Rod End Styles and Dimensions" page.

Style No. 2-Standard
Threaded on Turndown Section

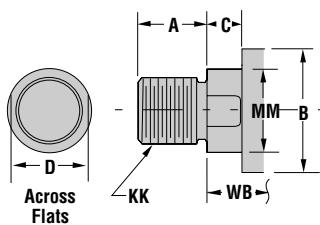

Style No. 4
Short Rod End-Internal Threads

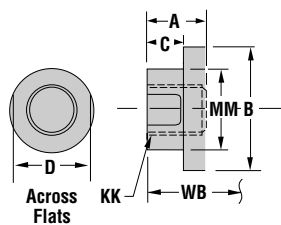

Style No. 5
Threaded Intermediate Male

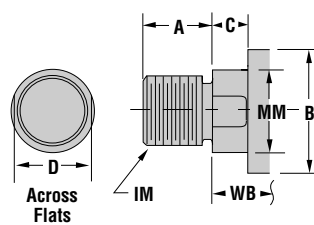

Miller H Series Hydraulic Cylinders

Side Lug/Centerline Lug 10"–14" Bore Cylinders

Model 72-B (NFPA MS2) Bolted Bushing Side Lug

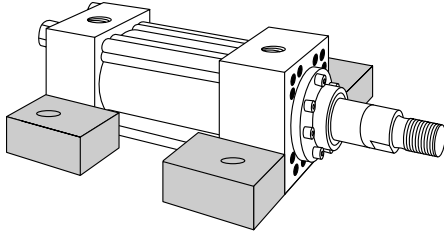

Mounting Dimensions (See tables on opposite page)

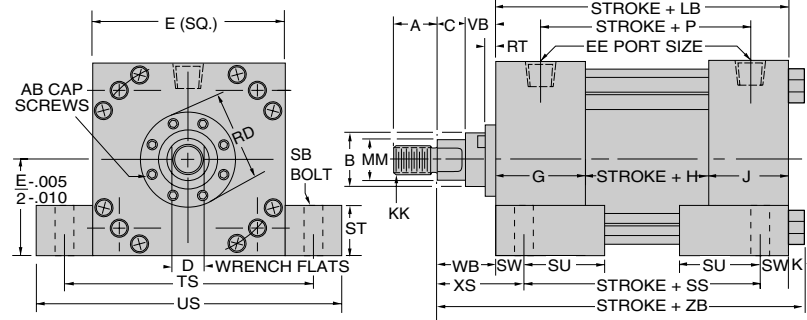

Note: Lugs should be blocked on the appropriate end to absorb hydraulic or mechanical shock. Bolts should not carry shear load. See Keying and Pinning Cylinders page.

Model 73-B (NFPA MS3) Bolted Bushing Centerline Lug

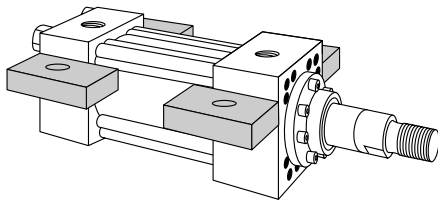

Mounting Dimensions (See tables on opposite page)

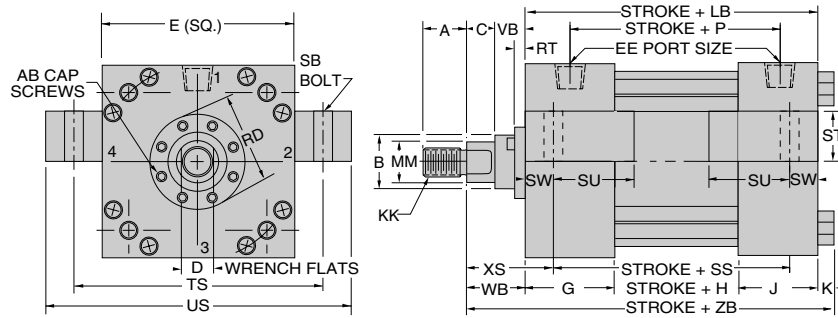

Note: Lugs should be blocked on the appropriate end to absorb hydraulic or mechanical shock. Bolts should not carry shear load. See Keying and Pinning Cylinders page.

Common Rod End Styles & Dimensions

For additional standard rod ends, see "Rod End Styles and Dimensions" page.

Style No. 2-Standard Threaded on Turndown Section

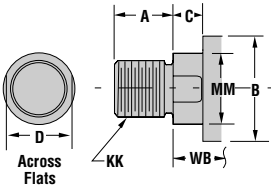

Style No. 4 Short Rod End-Internal Threads

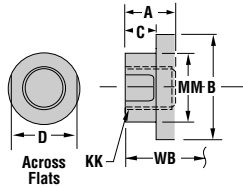

Style No. 5 Threaded Intermediate Male

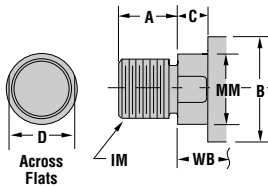

Style No. 6 Studded Rod End (Available Thru 2" Rod Diameter)

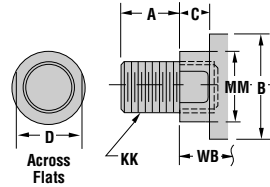

"Special" Thread Style X
Special thread, extension, rod eye, blank, etc., are also available.
To order, specify "Style X" and give desired dimensions for KK, A, WB or W. If otherwise special, furnish dimensioned sketch.

Miller H Series Hydraulic Cylinders

Side Lug/Centerline Lug 10"–14" Bore Cylinders

Cylinder Body Dimensions

Bore	E	G	J	K	*EE		SB	ST	SU	SW	TS	US
					SAE	NPTF						
10	12 ⁵ / ₈	3 ¹¹ / ₁₆	3 ¹¹ / ₁₆	1 ¹ / ₂	-32	2	1 ¹ / ₂	2 ¹ / ₄	3 ¹ / ₂	1 ⁵ / ₈	15 ⁷ / ₈	19 ¹ / ₈
12	15 ¹ / ₈	4 ⁷ / ₁₆	4 ⁷ / ₁₆	1 ¹ / ₂	-32	2 ¹ / ₂	1 ¹ / ₂	3	4 ¹ / ₄	2	19 ¹ / ₈	23 ³ / ₈
14	17 ¹ / ₂	4 ⁷ / ₈	4 ⁷ / ₈	1 ¹ / ₂	-32	3	1 ¹ / ₂	4	5	2 ¹ / ₂	22 ¹ / ₂	27 ¹ / ₂

*SAE ports are standard, NPTF ports are available at no extra charge.

Add Stroke

H	LB	LD	P	SS
4 ³ / ₄	12 ¹ / ₈	12 ¹ / ₈	8	8 ⁷ / ₈
5 ⁵ / ₈	14 ¹ / ₂	14 ¹ / ₂	9 ³ / ₈	10 ¹ / ₂
5 ⁷ / ₈	15 ⁵ / ₈	15 ⁵ / ₈	10 ³ / ₈	10 ⁵ / ₈

Rod End Dimensions

Bore	Rod Dia Size	A	B -.001 to -.003	C	D	AB	KK	RD	RT MAX.	VB	WB
10"	4 ¹ / ₂ "	4 ¹ / ₂	5.250	1 ¹¹ / ₁₆ *	3 ⁷ / ₈	5 ⁵ / ₁₆ -24	3 ¹ / ₄ -12	6.439	.610	1 ¹ / ₄	2 ¹⁵ / ₁₆
	5"	5	5.750	1 ¹⁵ / ₁₆ *	4 ¹ / ₄	5 ⁵ / ₁₆ -24	3 ¹ / ₂ -12	6.939	.610	1 ¹ / ₄	3 ³ / ₁₆
	5 ¹ / ₂ "	5 ¹ / ₂	6.250	1 ¹⁵ / ₁₆ *	4 ⁵ / ₈	5 ⁵ / ₁₆ -24	4-12	7.439	.610	1 ¹ / ₄	3 ³ / ₁₆
	7"	7	7.750	1	6 ¹ / ₈	5 ⁵ / ₁₆ -24	5 ¹ / ₂ -12	8.939	.610	2 ⁷ / ₁₆	3 ⁷ / ₁₆
12"	5 ¹ / ₂ "	5 ¹ / ₂	6.250	1 ¹⁵ / ₁₆ *	4 ⁵ / ₈	5 ⁵ / ₁₆ -24	4-12	7.439	.610	1 ¹ / ₄	3 ³ / ₁₆
	7"	7	7.750	1	6 ¹ / ₈	5 ⁵ / ₁₆ -24	5 ¹ / ₂ -12	8.939	.610	2 ⁷ / ₁₆	3 ⁷ / ₁₆
	8"	8	8.750	1	6 ⁷ / ₈	5 ⁵ / ₁₆ -24	5 ³ / ₄ -8	9.939	.610	2 ⁷ / ₁₆	3 ⁷ / ₁₆
14"	7"	7	7.750	1	6 ¹ / ₈	5 ⁵ / ₁₆ -24	5 ¹ / ₂ -12	8.939	.610	2 ⁷ / ₁₆	3 ⁷ / ₁₆
	8"	8	8.750	1	6 ⁷ / ₈	5 ⁵ / ₁₆ -24	5 ³ / ₄ -8	9.939	.610	2 ⁷ / ₁₆	3 ⁷ / ₁₆
	9"	9	9.750	1	7 ⁷ / ₈	5 ⁵ / ₁₆ -24	6 ¹ / ₂ -8	10.939	.610	2 ⁷ / ₁₆	3 ⁷ / ₁₆
	10"	10	10.750	1	8 ⁵ / ₈	5 ⁵ / ₁₆ -24	7-8	11.939	.610	2 ⁷ / ₁₆	3 ⁷ / ₁₆

*Wrench flats are 1" long these sizes

Add Stroke

XS	ZB
4 ⁹ / ₁₆	16 ⁹ / ₁₆
4 ¹³ / ₁₆	16 ¹³ / ₁₆
4 ¹³ / ₁₆	16 ¹³ / ₁₆
5 ¹ / ₁₆	17 ¹ / ₁₆
5 ³ / ₁₆	19 ³ / ₁₆
5 ⁷ / ₁₆	19 ⁷ / ₁₆
5 ⁷ / ₁₆	19 ⁷ / ₁₆
5 ¹⁵ / ₁₆	20 ⁹ / ₁₆
5 ¹⁵ / ₁₆	20 ⁹ / ₁₆
5 ¹⁵ / ₁₆	20 ⁹ / ₁₆
5 ¹⁵ / ₁₆	20 ⁹ / ₁₆

Model 72 cylinders have mounting lugs welded to the head and cap, and are considered to be a fixed mount that does not absorb force on its centerline. The plane of the mounting surface is not through the centerline of the cylinder, and for this reason Model 72 cylinders produce a turning moment as the cylinder applies force to the load. This turning moment tends to rotate the cylinder about its mounting bolts. If the cylinder is not well secured to the machine member on which it is mounted or the load is not well-guided, this turning moment results in side load applied to rod bushing and piston bearings. To avoid this problem, Model 72 cylinders should be specified with a stroke length at least equal to the bore size.

Pressure Limitations For Model 72-B

Bore	10	12	14
Pressure (PSI)	1230	1320	1200

Pressure Limitations For Model 73-B

Bore	10	12	14
Pressure (PSI)	1320	1480	1620

Miller H Series Hydraulic Cylinders

Trunnion Head End/Cap End 10"–14" Bore Cylinders

Model 81-B (NFPA MT1) Bolted Bushing Trunnion Head End

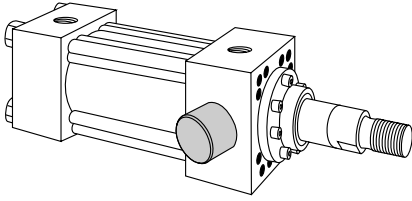

Mounting Dimensions (See tables on opposite page)

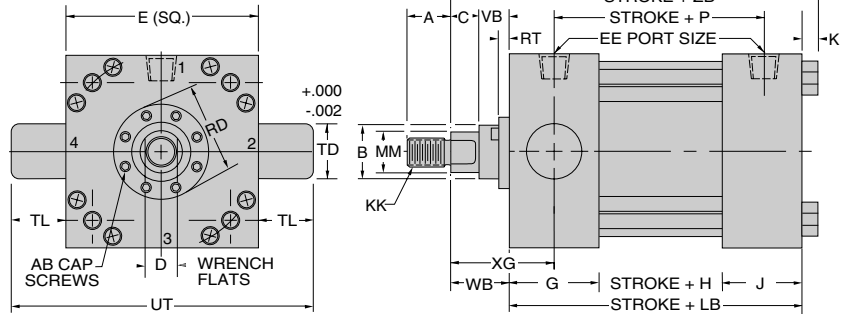

Note: Pins designed for shear, (not bending) loads.

Model 82-B (NFPA MT2) Bolted Bushing Trunnion Cap End

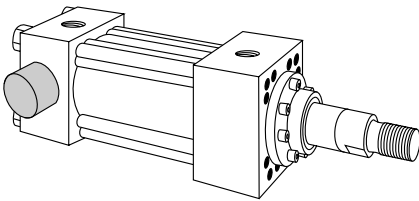

Mounting Dimensions (See tables on opposite page)

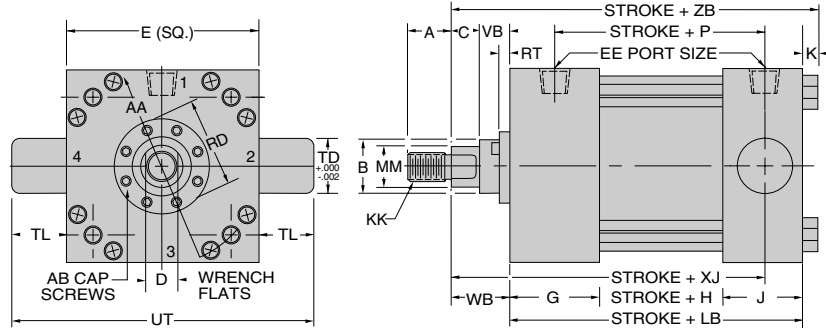

Note: Pins designed for shear, (not bending) loads.

Common Rod End Styles & Dimensions

For additional standard rod ends, see "Rod End Styles and Dimensions" page.

Style No. 2-Standard Threaded on Turndown Section

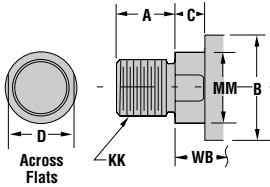

Style No. 4 Short Rod End-Internal Threads

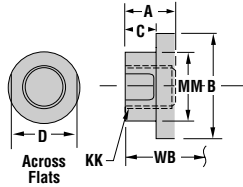

Style No. 5 Threaded Intermediate Male

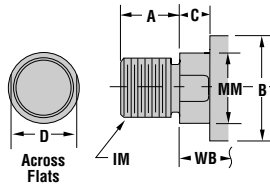

Style No. 6 Studded Rod End (Available Thru 2" Rod Diameter)

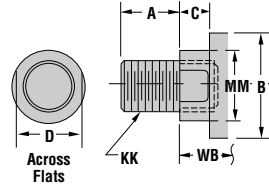

"Special" Thread Style X
Special thread, extension, rod eye, blank, etc., are also available.
To order, specify "Style X" and give desired dimensions for KK, A, WB or W. If otherwise special, furnish dimensioned sketch.

Pressure Limitations For Models 81-B & 82-B

Bore	10	12	14
Pressure (PSI)	900	760	870

Miller H Series Hydraulic Cylinders

Trunnion Head End/Cap End 10"–14" Bore Cylinders

Cylinder Body Dimensions

Bore	E	G	J	K	*EE		TD	TL	UT
					SAE	NPTF			
10	12 ⁵ / ₈	3 ¹¹ / ₁₆	3 ¹¹ / ₁₆	1 ¹ / ₂	-32	2	3 ¹ / ₂	3 ¹ / ₂	19 ⁵ / ₈
12	15 ¹ / ₈	4 ⁷ / ₁₆	4 ⁷ / ₁₆	1 ¹ / ₂	-32	2 ¹ / ₂	4	4	23 ³ / ₈
14	17 ¹ / ₂	4 ⁷ / ₈	4 ⁷ / ₈	1 ¹ / ₂	-32	3	5	5	27 ¹ / ₂

*SAE ports are standard, NPTF ports are available at no extra charge.

Add Stroke

H	LB	LD	P
4 ³ / ₄	12 ¹ / ₈	12 ¹ / ₈	8
5 ⁵ / ₈	14 ¹ / ₂	14 ¹ / ₂	9 ³ / ₈
5 ⁷ / ₈	15 ⁵ / ₈	15 ⁵ / ₈	10 ³ / ₈

Rod End Dimensions

Bore	Rod Dia Size	A	B -.001 to -.003	C	D	AB	KK	RD	RT MAX.	VB	WB	XG
10"	4 ¹ / ₂ "	4 ¹ / ₂	5.250	1 ¹¹ / ₁₆ "	3 ⁷ / ₈	5 ⁵ / ₁₆ -24	3 ¹ / ₄ -12	6.439	.610	1 ¹ / ₄	2 ¹⁵ / ₁₆	4 ³ / ₄
	5"	5	5.750	1 ¹⁵ / ₁₆ "	4 ¹ / ₄	5 ⁵ / ₁₆ -24	3 ¹ / ₂ -12	6.939	.610	1 ¹ / ₄	3 ³ / ₁₆	5
	5 ¹ / ₂ "	5 ¹ / ₂	6.250	1 ¹⁵ / ₁₆ "	4 ⁵ / ₈	5 ⁵ / ₁₆ -24	4-12	7.439	.610	1 ¹ / ₄	3 ³ / ₁₆	5
	7"	7	7.750	1	6 ¹ / ₈	5 ⁵ / ₁₆ -24	5 ¹ / ₂ -12	8.939	.610	2 ⁷ / ₁₆	3 ⁷ / ₁₆	5 ¹ / ₄
12"	5 ¹ / ₂ "	5 ¹ / ₂	6.250	1 ¹⁵ / ₁₆ "	4 ⁵ / ₈	5 ⁵ / ₁₆ -24	4-12	7.439	.610	1 ¹ / ₄	3 ³ / ₁₆	5 ³ / ₈
	7"	7	7.750	1	6 ¹ / ₈	5 ⁵ / ₁₆ -24	5 ¹ / ₂ -12	8.939	.610	2 ⁷ / ₁₆	3 ⁷ / ₁₆	5 ⁵ / ₈
	8"	8	8.750	1	6 ⁷ / ₈	5 ⁵ / ₁₆ -24	5 ³ / ₄ -8	9.939	.610	2 ⁷ / ₁₆	3 ⁷ / ₁₆	5 ⁵ / ₈
14"	7"	7	7.750	1	6 ¹ / ₈	5 ⁵ / ₁₆ -24	5 ¹ / ₂ -12	8.939	.610	2 ⁷ / ₁₆	3 ⁷ / ₁₆	5 ¹³ / ₁₆
	8"	8	8.750	1	6 ⁷ / ₈	5 ⁵ / ₁₆ -24	5 ³ / ₄ -8	9.939	.610	2 ⁷ / ₁₆	3 ⁷ / ₁₆	5 ¹³ / ₁₆
	9"	9	9.750	1	7 ⁷ / ₈	5 ⁵ / ₁₆ -24	6 ¹ / ₂ -8	10.939	.610	2 ⁷ / ₁₆	3 ⁷ / ₁₆	5 ¹³ / ₁₆
	10"	10	10.750	1	8 ⁵ / ₈	5 ⁵ / ₁₆ -24	7-8	11.939	.610	2 ⁷ / ₁₆	3 ⁷ / ₁₆	5 ¹³ / ₁₆

*Wrench flats are 1" long these sizes

Add Stroke

XJ	ZB
13 ⁵ / ₁₆	16 ⁹ / ₁₆
13 ⁹ / ₁₆	16 ¹³ / ₁₆
13 ⁹ / ₁₆	16 ¹³ / ₁₆
13 ¹³ / ₁₆	17 ¹ / ₁₆
15 ⁹ / ₁₆	19 ³ / ₁₆
15 ¹³ / ₁₆	19 ⁷ / ₁₆
15 ¹³ / ₁₆	19 ⁷ / ₁₆
16 ³ / ₄	20 ⁹ / ₁₆
16 ³ / ₄	20 ⁹ / ₁₆
16 ³ / ₄	20 ⁹ / ₁₆
16 ³ / ₄	20 ⁹ / ₁₆

Miller H Series Hydraulic Cylinders

Intermediate Trunnion 10"–12" Bore Cylinders

Model 89-B (NFPA MT4) Bolted Bushing Intermediate Trunnion

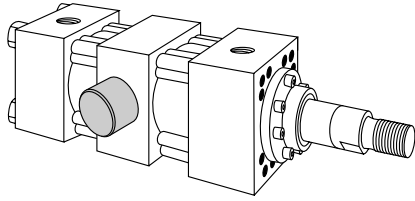

Mounting Dimensions (See tables on opposite page)

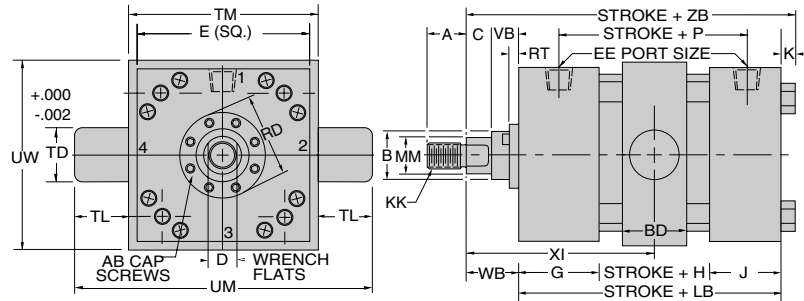

Note: Pins designed for shear (not bending) loads.
Specify dimension "XI" when ordering.

Common Rod End Styles & Dimensions

For additional standard rod ends, see "Rod End Styles and Dimensions" page.

Style No. 2-Standard Threaded on Turndown Section

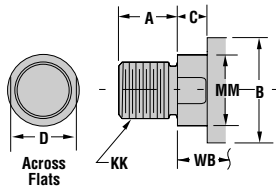

Style No. 4 Short Rod End-Internal Threads

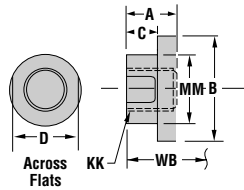

Style No. 5 Threaded Intermediate Male

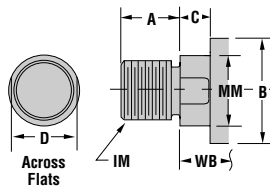

Style No. 6 Studded Rod End (Available Thru 2" Rod Diameter)

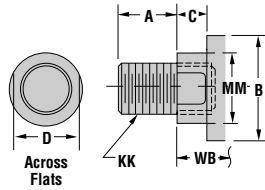

"Special" Thread Style X
Special thread, extension, rod eye, blank, etc., are also available.
To order, specify "Style X" and give desired dimensions for KK, A, WB or W. If otherwise special, furnish dimensioned sketch.

Pressure Limitations, Minimum XI and Minimum Stroke For Model 89-B

Bore	10	12
Pressure (PSI)	624	546
Min. XI	9 5/8	10 7/8
Min. Stroke	.25	.375

Miller H Series Hydraulic Cylinders

Intermediate Trunnion 10"–12" Bore Cylinders

Cylinder Body Dimensions

Bore	E	G	J	K	BD	*EE		TD	TL	TM	UM	UW
						SAE	NPTF					
10	12 ⁵ / ₈	3 ¹¹ / ₁₆	3 ¹¹ / ₁₆	1 ¹ / ₂	4 ¹ / ₂	-32	2	3 ¹ / ₂	3 ¹ / ₂	14	21	16
12	15 ¹ / ₈	4 ⁷ / ₁₆	4 ⁷ / ₁₆	1 ¹ / ₂	5 ¹ / ₂	-32	2 ¹ / ₂	4	4	16 ¹ / ₂	24 ¹ / ₂	20

*SAE ports are standard, NPTF ports are available at no extra charge.

Add Stroke

H	LB	LD	P
4 ³ / ₄	12 ¹ / ₈	12 ¹ / ₈	8
5 ⁵ / ₈	14 ¹ / ₂	14 ¹ / ₂	9 ³ / ₈

Rod End Dimensions

Bore	Rod Dia Size	A	B -.001 to -.003	C	D	AB	KK	RD	RT MAX.	VB	WB
10"	4 ¹ / ₂ "	4 ¹ / ₂	5.250	1 ¹¹ / ₁₆ "	3 ⁷ / ₈	5 ⁵ / ₁₆ -24	3 ¹ / ₄ -12	6.439	.610	1 ¹ / ₄	2 ¹⁵ / ₁₆
	5"	5	5.750	1 ¹⁵ / ₁₆ "	4 ¹ / ₄	5 ⁵ / ₁₆ -24	3 ¹ / ₂ -12	6.939	.610	1 ¹ / ₄	3 ³ / ₁₆
	5 ¹ / ₂ "	5 ¹ / ₂	6.250	1 ¹⁵ / ₁₆ "	4 ⁵ / ₈	5 ⁵ / ₁₆ -24	4-12	7.439	.610	1 ¹ / ₄	3 ³ / ₁₆
	7"	7	7.750	1	6 ¹ / ₈	5 ⁵ / ₁₆ -24	5 ¹ / ₂ -12	8.939	.610	2 ⁷ / ₁₆	3 ⁷ / ₁₆
12"	5 ¹ / ₂ "	5 ¹ / ₂	6.250	1 ¹ / ₂ "	4 ⁵ / ₈	5 ⁵ / ₁₆ -24	4-12	7.439	.610	1 ¹ / ₄	3 ³ / ₁₆
	7"	7	7.750	1	6 ¹ / ₈	5 ⁵ / ₁₆ -24	5 ¹ / ₂ -12	8.939	.610	2 ⁷ / ₁₆	3 ⁷ / ₁₆
	8"	8	8.750	1	6 ⁷ / ₈	5 ⁵ / ₁₆ -24	5 ³ / ₄ -8	9.939	.610	2 ⁷ / ₁₆	3 ⁷ / ₁₆

*Wrench flats are 1" long these sizes

Add Stroke

ZB
16 ⁹ / ₁₆
16 ¹³ / ₁₆
16 ¹³ / ₁₆
17 ¹ / ₁₆
19 ³ / ₁₆
19 ⁷ / ₁₆
19 ⁷ / ₁₆

Miller H Series Hydraulic Cylinders

Fixed Clevis and Rear Eye 10"–20" Bore Cylinders

Model 84-B Bolted Bushing Fixed Clevis

Mounting Dimensions (See tables on opposite page)

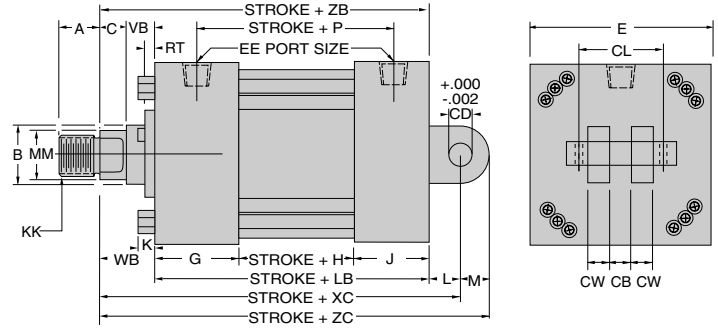
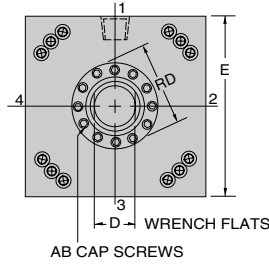
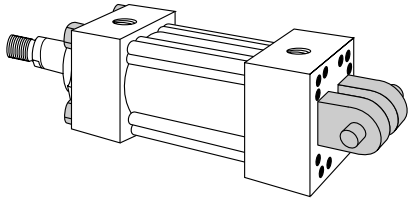

Model 90-B Bolted Bushing Rear Eye

Mounting Dimensions (See tables on opposite page)

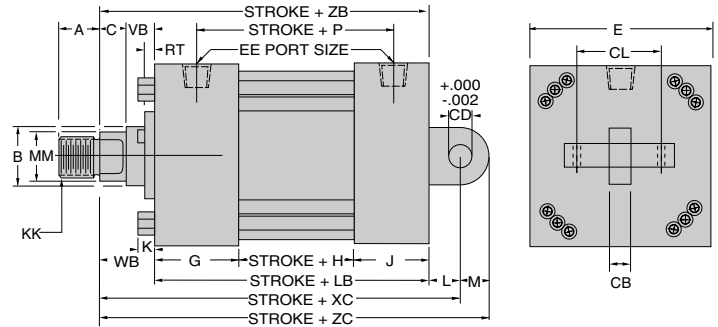
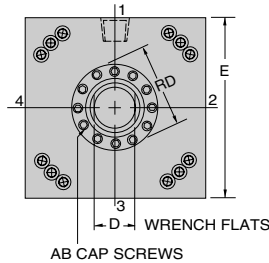
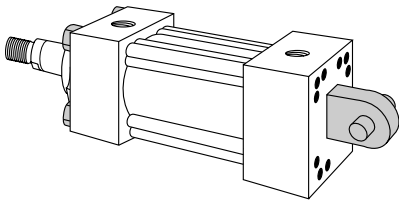

Pressure Limitations For Models 84-B & 90-B

Bore	10	12	14	16	18	20
Pressure (PSI)	3000	3000	2510	2500	2660	2620

Common Rod End Styles & Dimensions

For additional standard rod ends, see "Rod End Styles and Dimensions" page.

Style No. 2-Standard Threaded on Turndown Section

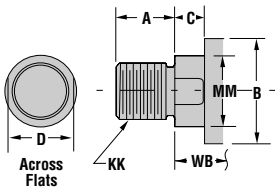

Style No. 4 Short Rod End-Internal Threads

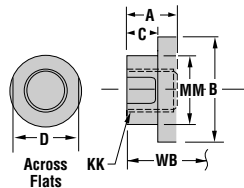

Style No. 5 Threaded Intermediate Male

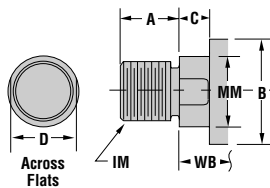

Style No. 6 Studded Rod End (Available Thru 2" Rod Diameter)

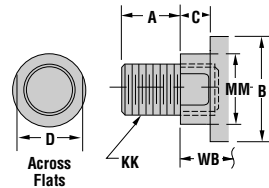

"Special" Thread Style X
Special thread, extension, rod eye, blank, etc., are also available.
To order, specify "Style X" and give desired dimensions for KK, A, WB or W. If otherwise special, furnish dimensioned sketch.

Miller H Series Hydraulic Cylinders

Fixed Clevis and Rear Eye 10"–20" Bore Cylinders

Cylinder Body Dimensions

Bore Size	E	G	J	K	L	M	*EE		CB	CD	CL	CW
							SAE	NPTF				
10	12 ⁵ / ₈	3 ¹¹ / ₁₆	3 ¹¹ / ₁₆	1 ¹ / ₂	4	3 ¹ / ₂	-32	2	4	3 ¹ / ₂	8.41	2
12	15 ¹ / ₈	4 ⁷ / ₁₆	4 ⁷ / ₁₆	1 ¹ / ₂	4 ¹ / ₂	4	-32	2 ¹ / ₂	4 ¹ / ₂	4	9.41	2 ¹ / ₄
14	17 ¹ / ₂	4 ⁷ / ₈	4 ⁷ / ₈	1 ¹ / ₂	5 ³ / ₄	5	-32	3	6	5	12.47	3
16	20 ¹ / ₂	5 ⁷ / ₈	5 ⁷ / ₈	1 ¹ / ₂	6 ³ / ₄	6	-32	4	6 ¹ / ₂	6	13.50	3 ¹ / ₄
18	23	6 ³ / ₈	6 ³ / ₈	1 ¹³ / ₁₆	7 ³ / ₄	7	-32	4	7 ¹ / ₂	7	15.47	3 ³ / ₄
20	25 ¹ / ₂	7 ³ / ₈	7 ³ / ₈	1 ¹³ / ₁₆	8 ³ / ₄	8	-32	5	8	8	16.53	4

*SAE ports are standard, NPTF ports are available at no extra charge.

Add Stroke

H	P	LB
4 ³ / ₄	8	12 ¹ / ₈
5 ⁵ / ₈	9 ³ / ₈	14 ¹ / ₂
5 ⁷ / ₈	10 ³ / ₈	15 ⁵ / ₈
6 ⁷ / ₈	12 ³ / ₄	18 ⁵ / ₈
8 ¹ / ₄	14 ¹ / ₄	21
9 ¹ / ₄	16	24

Rod End Dimensions

Bore Size	Rod Dia	A	B -.001 to -.003	C	D	AB	CC	KK	RD MAX.	RT	VB	WB
10"	4 ¹ / ₂ "	4 ¹ / ₂	5.250	1 ¹¹ / ₁₆ "	3 ⁷ / ₈	5 ¹ / ₁₆ -24	4 ¹ / ₂ -12	3 ¹ / ₄ -12	6.439	.610	1 ¹ / ₄	2 ¹⁵ / ₁₆
	5"	5	5.750	1 ¹⁵ / ₁₆ "	4 ¹ / ₄	5 ¹ / ₁₆ -24	5-12	3 ¹ / ₂ -12	6.939	.610	1 ¹ / ₄	3 ³ / ₁₆
	5 ¹ / ₂ "	5 ¹ / ₂	6.250	1 ¹⁵ / ₁₆ "	4 ⁵ / ₈	5 ¹ / ₁₆ -24	5 ¹ / ₂ -12	4-12	7.439	.610	1 ¹ / ₄	3 ³ / ₁₆
	7"	7	7.750	1	6 ¹ / ₈	5 ¹ / ₁₆ -24	7-8	5 ¹ / ₂ -12	8.939	.610	2 ⁷ / ₁₆	3 ⁷ / ₁₆
12"	5 ¹ / ₂ "	5 ¹ / ₂	6.250	1 ¹⁵ / ₁₆ "	4 ⁵ / ₈	5 ¹ / ₁₆ -24	5 ¹ / ₂ -12	4-12	7.439	.610	1 ¹ / ₄	3 ³ / ₁₆
	7"	7	7.750	1	6 ¹ / ₈	5 ¹ / ₁₆ -24	7-8	5 ¹ / ₂ -12	8.939	.610	2 ⁷ / ₁₆	3 ⁷ / ₁₆
	8"	8	8.750	1	6 ⁷ / ₈	5 ¹ / ₁₆ -24	8-6	5 ³ / ₄ -8	9.939	.610	2 ⁷ / ₁₆	3 ⁷ / ₁₆
14"	7"	7	7.750	1	6 ¹ / ₈	5 ¹ / ₁₆ -24	7-8	5 ¹ / ₂ -12	8.939	.610	2 ⁷ / ₁₆	3 ⁷ / ₁₆
	8"	8	8.750	1	6 ⁷ / ₈	5 ¹ / ₁₆ -24	8-6	5 ³ / ₄ -8	9.939	.610	2 ⁷ / ₁₆	3 ⁷ / ₁₆
	9"	9	9.750	1	7 ⁷ / ₈	5 ¹ / ₁₆ -24	9-6	6 ¹ / ₂ -8	10.939	.610	2 ⁷ / ₁₆	3 ⁷ / ₁₆
	10"	10	10.750	1	8 ⁵ / ₈	5 ¹ / ₁₆ -24	10-6	7-8	11.939	.610	2 ⁷ / ₁₆	3 ⁷ / ₁₆
16"	8"	8	8.750	1	6 ⁷ / ₈	5 ¹ / ₁₆ -24	8-6	5 ³ / ₄ -8	9.939	.610	2 ⁷ / ₁₆	3 ⁷ / ₁₆
	9"	9	9.750	1	7 ⁷ / ₈	5 ¹ / ₁₆ -24	9-6	6 ¹ / ₂ -8	10.939	.610	2 ⁷ / ₁₆	3 ⁷ / ₁₆
	10"	10	10.750	1	8 ⁵ / ₈	5 ¹ / ₁₆ -24	10-6	7-8	11.939	.610	2 ⁷ / ₁₆	3 ⁷ / ₁₆
18"	9"	9	9.750	1	7 ⁷ / ₈	5 ¹ / ₁₆ -24	9-6	6 ¹ / ₂ -8	10.939	.610	2 ⁷ / ₁₆	3 ⁷ / ₁₆
	10"	10	10.750	1	8 ⁵ / ₈	5 ¹ / ₁₆ -24	10-6	7-8	11.939	.610	2 ⁷ / ₁₆	3 ⁷ / ₁₆
20"	10"	10	10.750	1	8 ⁵ / ₈	5 ¹ / ₁₆ -24	10-6	7-8	11.939	.610	2 ⁷ / ₁₆	3 ⁷ / ₁₆

*Wrench flats are 1" long these sizes

Add Stroke

XC	ZB	ZC
19 ¹ / ₁₆	16 ⁹ / ₁₆	22 ⁹ / ₁₆
19 ⁵ / ₁₆	16 ¹³ / ₁₆	22 ¹³ / ₁₆
19 ⁹ / ₁₆	16 ¹³ / ₁₆	22 ¹³ / ₁₆
19 ⁹ / ₁₆	17 ¹ / ₁₆	23 ¹ / ₁₆
22 ² / ₁₆	19 ³ / ₁₆	26 ³ / ₁₆
22 ⁷ / ₁₆	19 ⁷ / ₁₆	26 ⁷ / ₁₆
22 ⁷ / ₁₆	19 ⁷ / ₁₆	26 ⁷ / ₁₆
24 ¹³ / ₁₆	20 ⁹ / ₁₆	29 ¹³ / ₁₆
24 ¹³ / ₁₆	20 ⁹ / ₁₆	29 ¹³ / ₁₆
24 ¹³ / ₁₆	20 ⁹ / ₁₆	29 ¹³ / ₁₆
24 ¹³ / ₁₆	20 ⁹ / ₁₆	29 ¹³ / ₁₆
28 ¹³ / ₁₆	23 ⁹ / ₁₆	34 ¹³ / ₁₆
28 ¹³ / ₁₆	23 ⁹ / ₁₆	34 ¹³ / ₁₆
28 ¹³ / ₁₆	23 ⁹ / ₁₆	34 ¹³ / ₁₆
32 ³ / ₁₆	26 ¹ / ₄	39 ³ / ₁₆
32 ³ / ₁₆	26 ¹ / ₄	39 ³ / ₁₆
36 ³ / ₁₆	29 ¹ / ₄	44 ³ / ₁₆

Miller H Series Hydraulic Cylinders

Rod End Styles and Dimensions

Rod End Styles

Rod End Style 2 is the standard rod end on Miller Fluid Power cylinders and will be furnished unless otherwise specified.

The rod end styles shown on this page represent most of the more commonly used rod end connections. If a rod end is required other than any of those shown, specify Style X. Give desired dimensions for KK, A, WB or W. If otherwise special, furnish dimensioned sketch.

Rod end modifications to your specifications can be readily made and could include a radius, a spherical radius, special thread size or length or both, keyway, special drilled holes and many other variations too numerous to mention.

Rod Dia. MM	A	AC	AD	AE	AF	AM	C	D	IM	KK	CC	LG
5/8	3/4	1 1/8	5/8	1/4	3/8	.57	3/8	1/2*	1/2-20	7/16-20	5/8-18	1/2
1	1 1/8	1 1/2	15/16	3/8	1 1/16	.95	1/2	7/8*	7/8-14	3/4-16	1-14	13/16
1 3/8	1 5/8	1 3/4	1 1/16	3/8	7/8	1.32	5/8	1 1/8	1 1/4-12	1-14	1 3/8-12	1 1/4
1 3/4	2	2	1 5/16	1/2	1 1/8	1.70	3/4	1 1/2	1 1/2-12	1 1/4-12	1 3/4-12	1 5/8
2	2 1/4	2 5/8	1 11/16	5/8	1 3/8	1.95	7/8	1 11/16	1 3/4-12	1 1/2-12	2-12	1 13/16
2 1/2	3	3 1/4	1 5/16	3/4	1 3/4	2.45	1	2 1/16	2 1/4-12	1 7/8-12	2 1/2-12	2 5/8
3	3 1/2	3 3/4	2 7/16	7/8	2 1/4	2.95	1	2 5/8	2 3/4-12	2 1/4-12	3-12	3 1/8
3 1/2	3 1/2	4 3/8	2 11/16	1	2 1/2	3.45	1	3	3 1/4-12	2 1/2-12	3 1/2-12	3 1/8
4	4	4 1/2	2 11/16	1	3	3.95	1	3 3/8	3 3/4-12	3-12	4-12	3 5/8
4 1/2	4 1/2	5 1/4	3 3/16	1 1/2	3 1/2	4.45	1**	3 7/8	4 1/4-12	3 1/4-12	4 1/2-12	4 1/8
5	5	5 3/8	3 3/16	1 1/2	3 7/8	4.95	1**	4 1/4	4 3/4-12	3 1/2-12	5-12	4 5/8
5 1/2	5 1/2	6 1/4	3 5/16	1 7/8	4 3/8	5.45	1**	4 5/8	5 1/4-12	4-12	5 1/2-12	5 1/8
7	7	6 †	4 1/16	2	5 3/4	6.95	1	6 1/8	6 1/2-12	5 1/2-12	7-8	6 5/8
8	8	6 1/4 †	4 1/16	2	6 1/2	7.95	1	6 7/8	6 1/2-12	5 3/4-8	8-6	7 5/8
9	9	6 5/16 †	4 5/8	2 3/8	7 1/4	8.95	1	7 7/8	8 1/2-12	6 1/2-8	9-6	8 5/8
10	10	7 5/16 †	4 5/8	2 3/8	8	9.95	1	8 5/8	9 1/2-12	7-8	10-6	9 5/8

*For Style #1 Rod End "D" Dimension: 5/8" Rod D = 7/16"
1" Rod D = 13/16"

** For 4 1/2" rod, the "C" dim. is 1 11/16 and the "A+C" dim. is 6 3/16 for 10 inch bore-H-series.
For 5" rod, the "C" dim. is 1 15/16 and the "A+C" dim. is 6 15/16 for 10 inch bore-H-series.
For 5 1/2" rod, the "C" dim. is 1 5/8 and the "A+C" dim. is 7 1/16 for 10 and 12 inch bore-H-series.

Wrench flats on these sizes are 1" long.

† In September 2003 most dimensions for the Style 9 end on 7-10 inch piston rods were revised. Customer orders for 7-10 inch Style 9 rod ends must specify required AC, AD, AE, AF, and AM dimensions.

Style 0 Plain Rod No Thread No Flats	
Style 1 Full Male Thread	
Style 2 Standard Turndown Male Thread	
Style 3 Long Rod Female Thread	
Style 4 Short Rod Female Thread	
Style 5 Intermediate Male Thread	
Style 6 Studded Rod End (Available thru 2" Rod Dia.)	
Style 7 Turndown Male Thread (2X A)	
Style 8 Intermediate Male Thread (2X A)	
Style 9† Flange Coupling Rod End	

Miller H Series Hydraulic Cylinders

Rod End Couplers

Dimensions

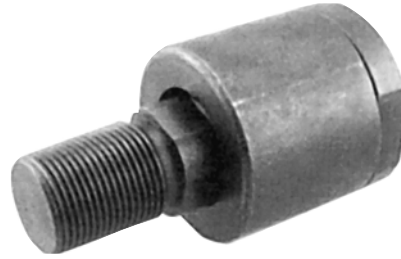

Good machine design practice requires that proper alignment be maintained to avoid excessive bearing loads. The Miller linear alignment rod end coupler can reduce minor cylinder misalignment problems, within design limitations. These couplers can be used for both push and pull applications.

Note: Use jam nut to lock coupler to rod when used with full diameter threads.

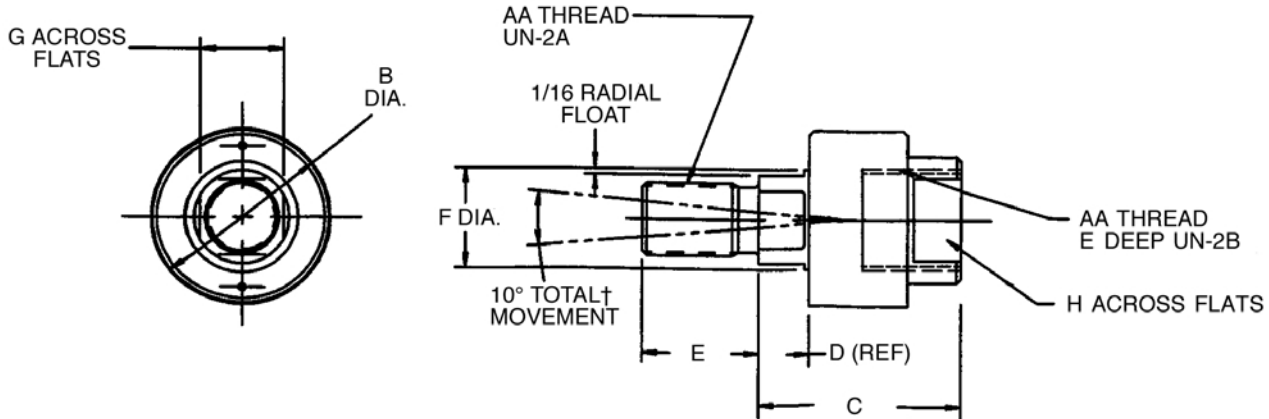

Part Numbers and Sizes

Part Number	AA	B	C	D	E	F	G	H	Max. Pull (LBS)
057-RCU03-44-20	7/16-20	1 3/8	2	17/32	3/4	5/8	1/2	7/8	3250
057-RCU03-50-20	1/2-20	1 3/8	2	17/32	3/4	5/8	1/2	7/8	4450
057-RCU03-63-18	5/8-18	1 3/8	2	17/32	3/4	5/8	1/2	7/8	6800
057-RCU03-75-16	3/4-16	2	2 5/16	19/32	1 1/8	15/16	3/4	1 5/16	9050
057-RCU03-88-14	7/8-14	2	2 5/16	19/32	1 1/8	15/16	3/4	1 5/16	14450
057-RCU03-100-14	1-14	3 1/8	3	15/32	1 5/8	1 7/16	1 1/4	1 7/8	19425
057-RCU03-125-12	1 1/4-12	3 1/8	3	15/32	1 5/8**	1 7/16	1 1/4	1 7/8	30500
057-RCU03-150-12	1 1/2-12	4	4 3/8	3/4	2 1/4	1 3/4	1 1/2	1 15/16	45750
057-RCU03-175-12	1 3/4-12	4	4 3/8	3/4	2 1/4	1 3/4	1 1/2	1 15/16	58350
057-RCU03-188-12	1 7/8-12	5	5 5/8	7/8	3	2 1/4	1 15/16	2 5/8	67550
057-RCU03-200-12	2-12	5	5 5/8	7/8	3	2 1/4	1 15/16	2 5/8	77450
057-RCU02-225-12	2 1/4-12	6 3/4	6 3/8	1	3 1/2	2 3/4	2 3/8	2 7/8	99250
057-RCU02-250-12	2 1/2-12	7	6 1/2	1	3 1/2	3 1/4	2 7/8	3 3/8	123750
057-RCU02-275-12	2 3/4-12	7	6 1/2	1	3 1/2	3 1/4	2 7/8	3 3/8	150950
057-RCU02-300-12	3-12	7	6 1/2	1	3 1/2**	3 1/4	2 7/8	3 3/8	180850
057-RCU02-325-12	3 1/4-12	9 1/4	8 1/2	1	4 1/2	4	3 3/8	4 1/2	213450
057-RCU02-425-12	4 1/4-12	12 7/8	11 1/4	1	4 1/2	5 1/2	4 7/8	7	370850

** 'E' thread is not deep enough to accept rod end style #2 standard 'A' thread length. Piston Rod style #2 thread for these sizes must be this 'E' dimension or shorter to permit torquing of Rod End Coupler to piston rod shoulder.

* Load in pounds. 4.1 safety factor.

† 10° Total Movement on 1 1/2"-12 thread and larger.

‡ 6° Total Movement on 7/16"-20 through 1 1/4"-12 thread.

On Long Stroke Horizontally Mounted Cylinder, see Determining Stop Tube Requirements pages.

Miller H Series Hydraulic Cylinders

Selecting Rod End Accessories

Pivot Pin

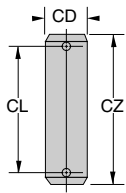

Eye Bracket

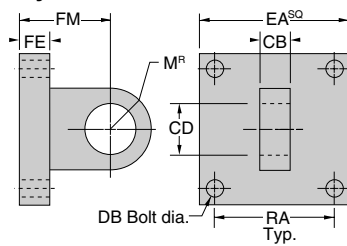

Clevis Bracket

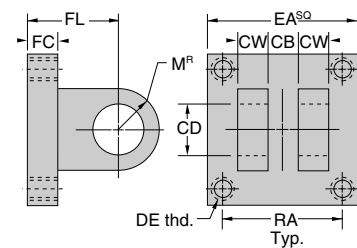

Pivot Pin Part No. Shear Load Capacity (lbs)	Eye Bracket Part No. Tensile Load Capacity (lbs)	Clevis Bracket Part No. Tensile Load Capacity (lbs)	Pin Dia	M	CB	CD	CL	CW	CZ	DB	DE	EA	FC	FE	FL	FM	RA
057-PP001-50 4,900	057-EB001-50 3,600	170-MB86A-150-50 5,000	1/2	1/2	3/4	1/2	1.94	1/2	2.28	3/8	3/8-24	2 1/2	3/8	3/8	1 1/8	1 1/8	1.63
057-PP001-75 11,000	— —	170-MB86A-200-75 11,000	3/4	3/4	1 1/4	3/4	2.72	5/8	3.09	—	1/2-20	3	5/8	—	1 7/8	—	2.05
— —	† 057-EB001-75 11,000	— —	3/4	3/4	1 1/4	3/4	2.72	—	3.09	1/2	—	3 1/2	—	5/8	—	1 7/8	2.55
057-PP001-75 11,000	— —	170-MB86A-250-75 11,000	3/4	3/4	1 1/4	3/4	2.72	5/8	3.09	1/2	1/2-20	3 1/2	5/8	5/8	1 7/8	1 7/8	2.55
057-PP001-100 19,600	057-EB001-100 17,000	170-MB86A-325-100 17,000	1	1	1 1/2	1	3.22	3/4	3.59	5/8	5/8-18	4 1/2	3/4	3/4	2 1/4	2 1/4	3.25
057-PP001-138 37,000	057-EB001-138 21,000	170-MB86A-400-138 30,000	1 3/8	1 3/8	2	1 3/8	4.25	1	4.66	5/8	5/8-18	5	7/8	7/8	3	3	3.82
057-PP001-175 60,000	057-EB002-175 51,000	170-MB86A-500-175 53,000	1 3/4	1 3/4	2 1/2	1 3/4	5.25	1 1/4	5.66	7/8	7/8-14	6 1/2	7/8	1	3 1/8	3 1/4	4.95
057-PP001-200 78,500	057-EB002-200 76,500	170-MB86A-600-200 75,000	2	2	2 1/2	2	5.28	1 1/4	5.72	1	1-14	7 1/2	1	1 1/2	3 1/2	4	5.73
057-PP001-250 122,700	057-EB002-250 94,500	170-MB86A-700-250 76,000	2 1/2	2 1/2	3	2 1/2	6.31	1 1/2	6.78	1 1/8	1 1/8-12	8 1/2	1	1 1/2	4	4 1/2	6.58
057-PP001-300 176,700	057-EB002-300 124,000	170-MB86A-800-300 114,000	3	2 3/4	3	3	6.34	1 1/2	6.84	1 1/4	1 1/4-12	9 1/2	1	2	4 1/4	5 1/4	7.50
057-PP001-350 240,500	057-EB002-350 140,000	170-MB86A-1000-350 152,700	3 1/2	3 1/2	4	3 1/2	8.41	2	8.97	1 3/4	1 3/4-12	12 5/8	1 1/16	2 7/8	5 1/16	6 7/8	9.62
057-PP001-400 314,000	057-EB002-400 180,000	170-MB86A-1200-400 225,000	4	4	4 1/2	4	9.41	2 1/4	9.97	2	2-12	15 1/8	1 5/16	3 3/8	6 7/16	7 7/8	11.45
057-PP001-500 491,000	057-EB002-500 292,700	—	5	5	6	5	12.47	—	13.09	2 1/4	—	17 1/2	—	4 3/8	—	10 1/8	13.25
057-PP001-600 707,000	057-EB002-600 390,000	—	6	6	6 1/2	6	13.50	—	14.09	2 1/2	—	20 1/2	—	4 7/8	—	11 5/8	15.5
057-PP001-700 962,000	057-EB002-700 454,600	—	7	7	7 1/2	7	15.47	—	16.09	3	—	23 1/4	—	5 3/8	—	13 1/8	17.25
057-PP001-800 1,256,000	057-EB002-800 572,700	—	8	8	8	8	16.53	—	17.16	3 1/2	—	25 1/2	—	5 7/8	—	14 5/8	18.5

† Dimensions apply to eye bracket only.

Note: Do not order clevis bracket to convert cylinders to 86 mounting. Contact factory.

Miller H Series Hydraulic Cylinders

Rod Eye

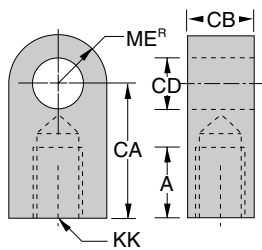

Rod Clevis

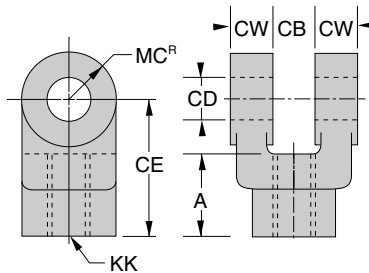

Rod Eye Part No. + Load Capacity (lbs)	Rod Clevis Part No. + Load Capacity (lbs)	Thd Size KK	A	MC	ME	CA	CB	CE	CD	CW
057-RE001-44-20 5,000	057-RC001-44-20 4,250	7/16-20	3/4	1/2	1/2	1 1/2	3/4	1 1/2	1/2	1/2
057-RE001-75-16 12,100	057-RC001-75-16 11,200	3/4-16	1 1/8	3/4	3/4	2 1/16	1 1/4	2 3/8	3/4	5/8
057-RE001-100-14 21,700	057-RC001-100-14 19,500	1-14	1 5/8	1	1	2 3/16	1 1/2	3 1/8	1	3/4
057-RE001-125-12 33,500	057-RC001-125-12 33,500	1 1/4-12	2	1 3/8	1 3/8	3 7/16	2	4 1/8	1 3/8	1
057-RE001-150-12 45,000	057-RC001-150-12 45,600	1 1/2-12	2 1/4	1 3/4	1 3/4	4	2 1/2	4 1/2	1 3/4	1 1/4
057-RE001-188-12 75,000	057-RC001-188-12 65,600	1 7/8-12	3	2	2	5	2 1/2	5 1/2	2	1 1/4
057-RE001-225-12 98,700	057-RC001-225-12 98,200	2 1/4-12	3 1/2	2 1/2	2 1/2	5 13/16	3	6 1/2	2 1/2	1 1/2
057-RE001-250-12 110,000	057-RC001-250-12 98,200	2 1/2-12	3 1/2	2 3/4	3	6 1/8	3	6 3/4	3	1 1/2
057-RE001-325-12 161,300	057-RC001-325-12 156,700	3 1/4-12	4 1/2	3 1/2	3 1/2	7 5/8	4	8 1/2	3 1/2	2
057-RE001-400-12 273,800	057-RC001-400-12 221,200	4-12	5 1/2	4	4	9 1/8	4 1/2	10	4	2 1/4
057-RE001-550-12 300,000	—	5 1/2-12	7	—	5	11 7/8	6	—	5	—
057-RE001-575-08 390,000	—	5 3/4-8	8	—	6	14 1/8	6 1/2	—	7	—
057-RE001-650-08 525,000	—	6 1/2-8	9	—	7	15 7/8	7 1/2	—	8	—

Miller H Series Hydraulic Cylinders

Cylinder Rod End Accessories

Cylinder Rod End Accessories are used to affix the piston rod to the load—most commonly when the cylinder pivots during operation.

Piston Rod Attachments

In attaching machinery components or rod clevises, rod eyes, etc. to Miller Styles 2 & 6 (Threaded on Turndown Section) or Styles 3 & 4 (Internally Threaded Piston Rods), the attachments should be tightened to the torques given in the Table at right. This torque or pre-stress triples the fatigue strength of the rod's threaded section and makes a stronger assembly than attaching the machinery component to a maximum diameter threaded rod (Style 5) and torquing it against a lock nut. Miller recommends the Style 2 (Threaded on Turndown Section) Rod for most applications. It's square shoulder design helps proper alignment of cylinder to mechanism, eliminates need for a jam nut, provides fixed point for more accurate cylinder positioning, and simplifies piloting of full rod diameter into mating part.

Pre-Stress Table: Piston Rods		
Rod Dia	Thread Size	Torque ft lbs*
5/8	7/16-20	36
1	3/4-16	125
1 3/8	1-14	250
1 3/4	1 1/4-12	460
2	1 1/2-12	663
2 1/2	1 7/8-12	944
3	2 1/4-12	1315
3 1/2	2 1/2-12	5050
4	3-12	7070
4 1/2	3 1/4-12	7940
5	3 1/2-12	12760
5 1/2	4-12	12560

*Recommended Torques (ft. lbs.) with MoS2 Lubricant or Equivalent.

Flange Coupling (For Use with Style #9 Rod End)

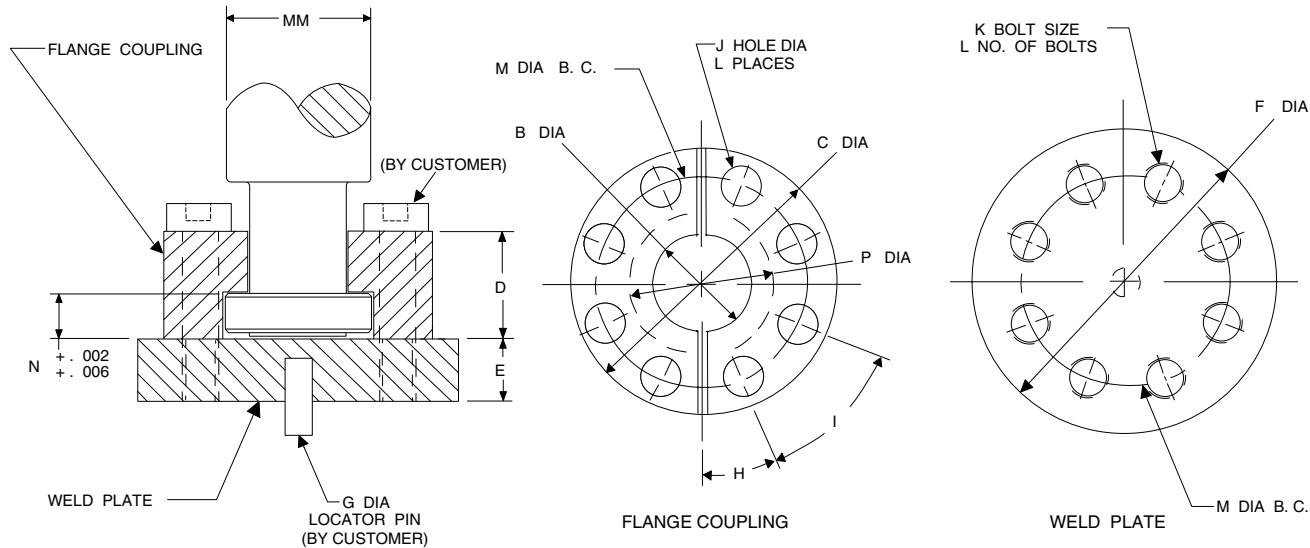

Flange Coupler Part No.	Weld Plate Part No.	MM	B	C	D	E	F	G	H	I	J	K	L	M	N	P
057-FC002-063	057-BA003-063	.625	.406	1.500	.562	.500	2.000	.250	45°	90°	.218	10-24	4	1.125	.250	.656
057-FC002-100	057-BA003-100	1.000	.750	2.000	.875	.500	2.500	.250	30°	60°	.281	1/4-20	6	1.500	.375	1.063
057-FC002-138	057-BA003-138	1.375	.938	2.500	1.000	.625	3.000	.250	30°	60°	.343	5/16-18	6	2.000	.375	1.438
057-FC002-175	057-BA003-175	1.750	1.187	3.000	1.250	.625	4.000	.250	22.5°	45°	.343	5/16-18	8	2.375	.500	1.813
057-FC002-200	057-BA003-200	2.000	1.438	3.500	1.625	.750	4.000	.375	15°	30°	.406	3/8-16	12	2.688	.625	2.063
057-FC003-250	057-BA004-250	2.500	1.875	4.000	1.875	.750	4.500	.375	15°	30°	.406	3/8-16	12	3.188	.750	2.625
057-FC002-300	057-BA003-300	3.000	2.375	5.000	2.375	1.000	5.500	.375	15°	30°	.531	1/2-13	12	4.000	.875	3.125
057-FC002-350	057-BA003-350	3.500	2.625	5.875	2.625	1.000	7.000	.375	15°	30°	.656	5/8-11	12	4.688	1.000	3.625
057-FC002-400	057-BA003-400	4.000	3.125	6.375	2.625	1.000	7.000	.375	15°	30°	.656	5/8-11	12	5.188	1.000	4.125
057-FC002-450	057-BA003-450	4.500	3.625	6.875	3.125	1.000	8.000	.375	15°	30°	.656	5/8-11	12	5.688	1.500	4.625
057-FC002-500	057-BA003-500	5.000	4.000	7.375	3.125	1.000	8.000	.375	15°	30°	.656	5/8-11	12	6.188	1.500	5.125
057-FC002-550	057-BA003-550	5.500	4.500	8.250	3.875	1.250	9.000	.375	15°	30°	.781	3/4-10	12	6.875	1.875	5.625
057-FC002-700	057-BA003-700	7.000	5.938	10.380	4.000	1.750	11.000	.500	15°	30°	1.031	1-8	12	8.750	2.000	7.125
057-FC002-800	057-BA003-800	8.000	6.690	11.380	4.000	2.000	12.000	.500	11.25°	22.5°	1.031	1-8	16	9.750	2.000	8.125
057-FC002-900	057-BA003-900	9.000	7.440	13.120	4.000	2.250	14.000	.500	15°	30°	1.281	1 1/4-7	12	11.125	2.375	9.125
057-FC002-1000	057-BA003-1000	10.000	8.250	14.120	4.500	2.500	15.000	.500	11.25°	22.5°	1.281	1 1/4-7	16	12.125	2.375	10.130

Note: Some dimensions for Flange Coupling and Weld Plate to fit 2 1/2 rod Style #9 machining changed in September 2003. Although the current and previous designs both fit Style #9 machining, the mounting bolt diameter has been reduced from 1/2 inch to 3/8 inch. There also has been a corresponding decrease in the Flange Coupling OD and bolt circle. For dimensional information on the older Flange Coupler and Mounting Plate, please consult the factory or previous editions of this catalog.

Miller H Series Hydraulic Cylinders

Cylinder Stroke Adjustment Options

Adjustable on Retract Stroke

Available at additional cost. Screw is furnished in cap end of cylinder and is designed for infrequent* stroke adjustment. Turning it in or out limits the retract stroke to the precise length desired. **Note: Stroke adjustments should be made at Zero fluid pressure only.** PTFE Tru-Seal fitting provides positive seal against leakage, as well as providing adjustment lock. Cap end cushion not available with this option.

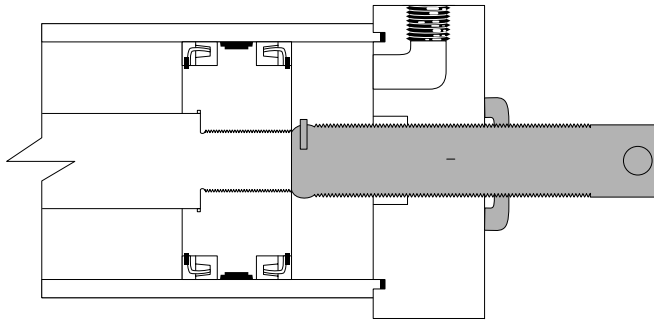

*Infrequent is defined by positioning the retract stroke in a couple of attempts at original machine set-up.

Adjustable on Extend Stroke

Available at additional cost. Using a double rod end cylinder, the extend stroke can be adjusted by repositioning the lock nuts on the threaded rod extension on the adjustment end.

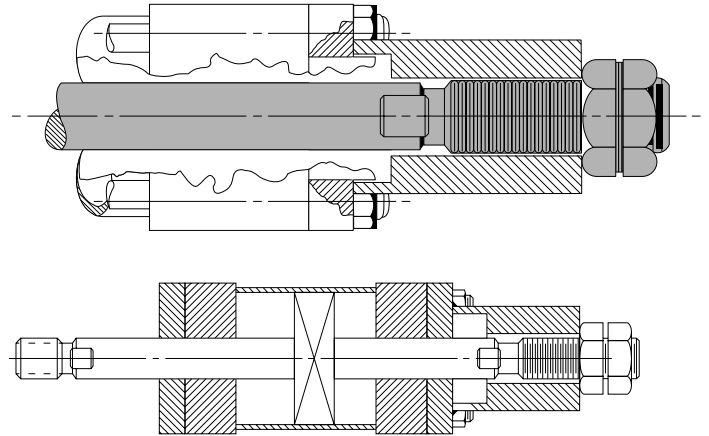

Other Available Cylinder Modifications

Rod End Modifications

Miller can produce a wide variety of custom rod end styles such as special threads and non-standard size turndowns. For unusual modifications, involving more than just a change in dimensions, submit a sketch or drawing to Miller for a determination as to cost and feasibility.

Special Ports

Standard H cylinder ports are SAE. However, equivalent NPTF or oversize SAE or NPTF ports are available as options.

Air Bleeds

Miller cylinders can be ordered with optional self or manual air bleeds.

Heavy Chromed Tubes and Piston Rods

Miller can provide an optional 0.002 to 0.003 inch heavy chrome plating on cylinder tube I.D. and piston rods.

Stainless Steel Piston Rods

Miller can supply cylinders with 17-4 or other types of stainless steel piston rods. Contact Miller Fluid Power application engineering department regarding any special piston rod material.

More Options

Fluorocarbon Seal Materials
Designs to meet specialized requirements: Nuclear, ASME, ABS, AWWA, SUB SEA, and Various Automotive Industry and Military Specifications.
Special Coatings and Painting
Grease Fitted Rod Bushing
External Drainback Bushing

End of Stroke Magnetic Principle Type Proximity Switch

Specify on Order:
Magnetic Principle Proximity Switch

Reliable: Proximity type sensor never contacts cylinder moving parts; eliminating wear and adjustments.

Positive Action: Multiple magnet design provides "snap action." Eliminates creep and false signals.

Versatile: Sealed stainless steel switch body can be used with any operating fluid and is impervious to most environmental conditions.

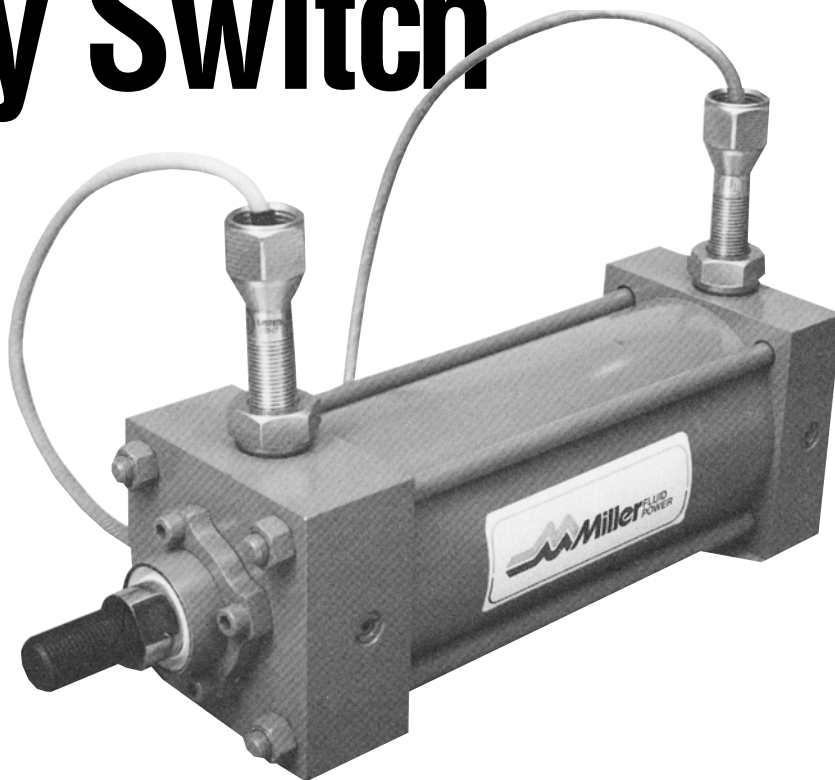

OPERATING PRINCIPLE

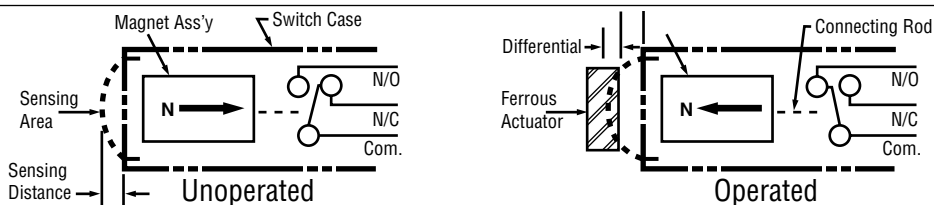

Switch Options

Pressure ratings to 5000 PSI.
Quick disconnect.
Explosion proof.
Sub sea, to 2000 feet depths.
Extra-long leads.

As shown in the sketches above, these switches are magnetically operated. Dual magnets provide a dependable "snap action" for positive position sensing.

In the "unoperated" position, the magnet assembly is attracted in the direction of the arrow, causing a finely ground stainless steel connecting rod to hold the contacts open.

In the "operated" position a ferrous part (cushion or piston) enters the sensing area and attracts the magnet assembly which causes the rod to draw the contacts closed.

Specifications

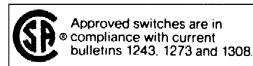

Switch Type:

Magnetic Principle

Contacts:

Single Pole-Double Throw (SPDT)

Contact Rating*:

2 Amp at 110-240 VAC (UL & CSA) 100 MA at 12 VDC 50 MA at 24 VDC (CSA)

Note: Check current draw of solenoid valves.

Connection: 36" long, 3 wire, potted in cable.

Can be wired Normally Open or Normally Closed. Leads are tagged (Com, N/O, N/C)

Pressure Rating: 3000 PSI Non Shock

Temperature Range:

- 20°F to + 200°F (UL 104°F. Max.)

Sensing Gap:

.030 to .060 inch

Trip Point: Factory Set with Piston Bottomed out

Release Point: Approximately 1/4" Piston Travel Min. Cyl. stroke 1/2" on 1 1/2" & 2" bore, 3/4" stroke on 2 1/2" and up.

*UL and CSA approved for industrial control, general purpose use. If Class I, Division 1 or 2 is required, please specify.

Miller H Series Hydraulic Cylinders

Switch Extension for Standard Side Position or Optional End Cap Position

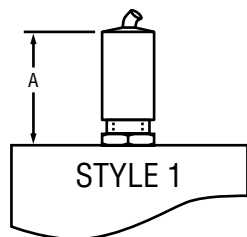

Standard location for switch mounting is any available side position. Please specify side location (1, 2, 3 or 4) desired. Cylinders are standardized as cushioned. Models 67/68 in positions #2 & #4 require special machining.

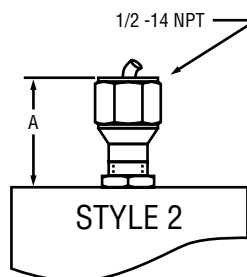

		SWITCH EXTENSION IN INCHES							
		EXCEPT MODEL 67/68 POS 2 OR 4				MODEL 67/68 POS 2 OR 4			
		HEAD		CAP		HEAD		CAP	
BORE	ROD	A	STYLE	A	STYLE	A	STYLE	A	STYLE
1½	.625	2.64	1	2.39	1	2.69	2	2.44	2
	1.000	2.76	1	2.39	1	2.82	2	2.44	2
2	1.000	2.57	1	2.26	1	2.44	2	2.13	2
	1.375	2.70	1	2.26	1	2.57	2	2.13	2
2½	1.000	3.25	2	2.94	2	2.19	2	1.88	2
	1.375	3.44	2	2.94	2	2.38	2	1.88	2
	1.750	3.57	2	2.94	2	2.50	2	1.88	2
3¼	1.375	2.94	2	2.57	2	3.13	2	2.75	2
	1.750	3.18	2	2.57	2	3.36	2	2.75	2
	2.000	3.32	2	2.57	2	2.00	2	2.75	2
4	1.750	2.93	2	2.32	2	3.11	2	2.50	2
	2.000	3.07	2	2.32	2	3.25	2	2.50	2
	2.500	3.38	2	2.32	2	2.07	2	2.50	2
5	2.000	2.32	2	1.75	2	2.19	2	1.63	2
	2.500	2.63	2	1.75	2	2.50	2	1.63	2
	3.000	2.94	2	1.75	2	2.82	2	1.63	2
	3.500	3.07	2	1.75	2	2.94	2	1.63	2
6	2.500	2.13	2	2.75	2				
	3.000	2.44	2	2.75	2	N/A		N/A	
	3.500	2.57	2	2.75	2				
	4.000	2.75	2	2.75	2				
7	3.000	1.94	2	2.44	2				
	3.500	2.13	2	2.44	2				
	4.000	2.38	2	2.44	2	N/A		N/A	
	4.500	2.63	2	2.44	2				
8	5.000	2.88	2	2.44	2				
	3.500	1.63	2	2.13	2				
	4.000	1.88	2	2.13	2				
	4.500	2.13	2	2.13	2	N/A		N/A	
	5.000	2.38	2	2.13	2				
5.500	2.63	2	2.13	2					

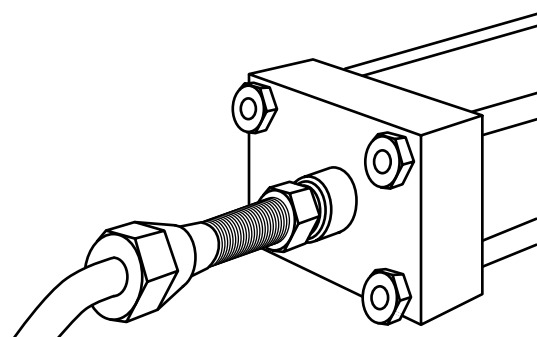

Optional mounting in rear face of cap does not require cushion.

TABLE SHOWING EXTENSION OF SWITCH FROM ENDCAP *

* NOTE: THE DEPTH TO WHICH A SWITCH IS INSTALLED MAY VARY AND STILL BE IN SENSING RANGE. THEREFORE, THE CALCULATED EXTENSION OF THE SWITCH IS APPROXIMATE.

How to order:

To order switches, enter a '9' in the Modified field of the cylinder model code. Describe the modification in notes by specifying:

1. Magnetic end of stroke switch
2. Installation in head, cap, or both ends of the cylinder
3. Location in the head or cap (position #1, 2, 3, or 4) not occupied by a port or mounting

Miller H Series Hydraulic Cylinders

End of Stroke Inductive Type Proximity Switch

All Switches are:

- Non-Contacting
- Water Resistant
- Weld-Field Immune
- Shock and Vibration Resistant
- Flange-Mounted to Cylinder End Caps

PEP-1 Switches

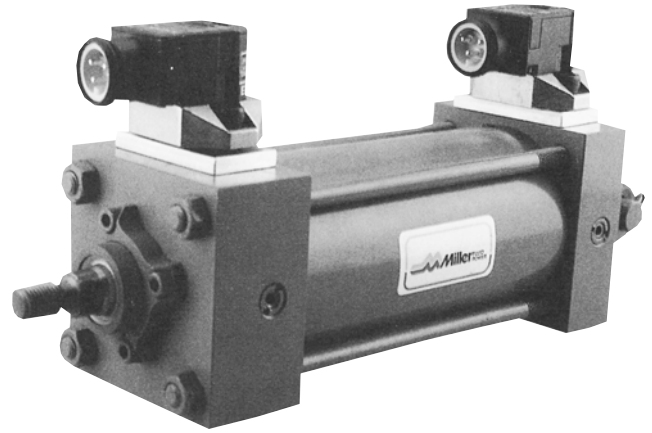
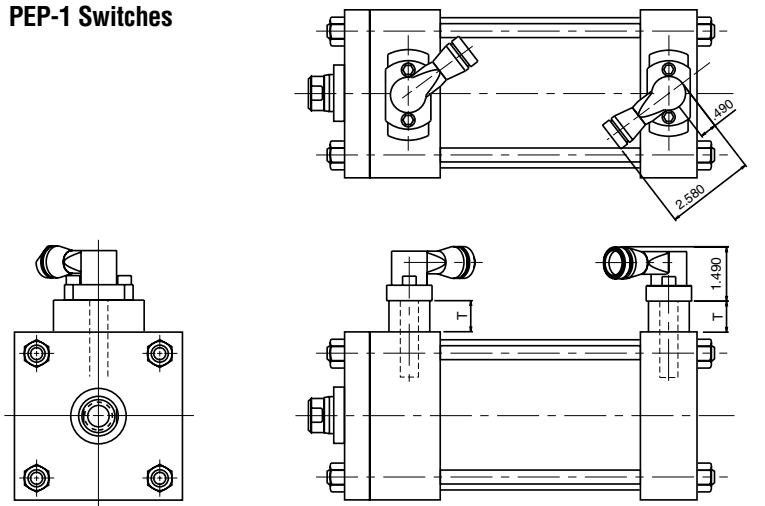

EPS-5 Automotive Applications

(Meets some Automotive Manufacturer's Specifications)

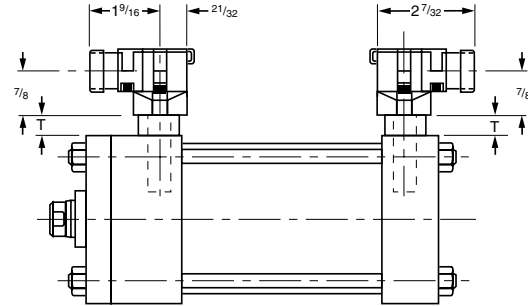
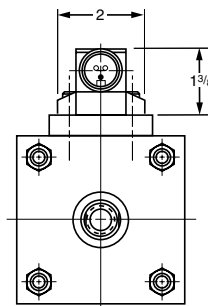

Series and Parallel Wiring

When Miller EPS-5 or PEP-1 proximity switches are used as inputs to programmable controllers the preferred practice is to connect each switch to a separate input channel of the PC. Series or parallel operations may then be accomplished by the internal PC programming.

Miller EPS-5 or PEP-1 switches may be hard wired for series operation, but the voltage drop through the switches (see specifications) must not reduce the available voltage below what is needed to actuate the load.

Miller EPS-5 or PEP-1 switches may also be hard wired for parallel operation. However, the leakage current of each switch will pass through the load. The total of all leakage currents must

not exceed the current required to actuate the load. In most cases, the use of two or more EPS-5 or PEP-1 switches in parallel will require the use of a bypass (shunt) resistor.

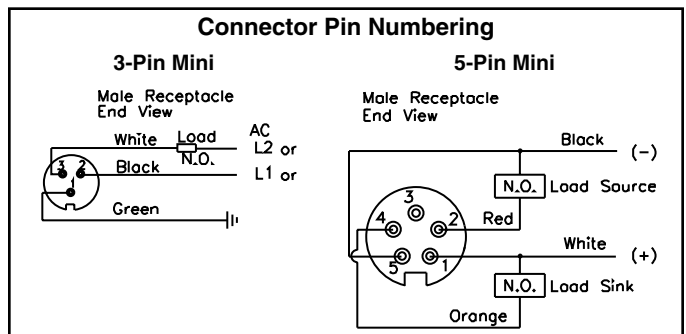

Miller H Series Hydraulic Cylinders

Specifications

Style:	PEP-1	EPS-5
Description:	Economical, General Purpose, 2 wire device, primarily for AC applications, not suitable for 24 VDC applications. Use EPS-5 only for automotive industry customers who specify them.	
Supply Voltage:	20 to 250 VAC/DC	20 to 230 VAC/DC
Load Current, min.:	8 mA	5 mA
Load Current, max.:	300 mA	500 mA
Leakage Current:	1.7 mA, max.	1.7 mA, max.
Voltage Drop:	7 V, max.	10 V, max
Operating Temperature:	-14° to +158° F	-4° to +158° F
Sensor Type:	Inductive proximity	Inductive proximity
Connection:	3 pin mini	3 pin mini
Enclosure Rating:	IEC IP67	NEMA 4, 6, 12, 13
LED Indication:	Yes	Yes
Short Circuit Protection:	Yes	Yes
Weld Field Immunity:	Yes	Yes
Output:	2 wire, Normally Open with leakage current	2 wire, Normally Open with leakage current
Approvals/Marks:	CE, UL, CSA	UL
Make/Break Location:	0.125" from end of stroke, typical tolerance is +0/- .125"	
Wiring Instructions:	Pin 1: AC Ground (Green) Pin 2: Output (Black) Pin 3: AC Line (White)	Pin 1: AC Ground (Green) Pin 2: Output (Black) Pin 3: AC Line (White)
Cable: 6'	085355-0006	085355-0006
Cable: 12'	085355-0012	085355-0012
Cable: 6', Right Angle	087547-0006	087547-0006

Standard location for switch mounting is any available side location. Please specify side location (1, 2, 3, or 4) desired.

BORE	All Models Except 67/68 In Position 2 & 4		Model 67/68 In Position 2 & 4	
	ROD	T	ROD	T
1½	.625	1.274	.625	1.212
	1.000	1.425	1.000	1.360
	CAP	1.024	CAP	0.962
2	1.000	0.175	1.000	0.154
	1.375	0.314	1.375	0.300
	CAP	0.900	CAP	0.649
2½	1.000	0.154	1.000	0.712
	1.375	0.112	1.375	0.900
	CAP	0.649	CAP	0.400
3¼	1.375	0.649	1.375	0.154
	1.750	0.884	1.750	0.381
	CAP	0.275	CAP	0.674
4	1.750	0.630	1.750	0.134
	2.000	0.774	2.000	0.275
	CAP	0.836	CAP	0.425
5	2.000	0.836	2.000	0.112
	2.500	0.336	2.500	0.425
	CAP	0.275	CAP	0.336
6	2.500	0.649	2.500	0.463
	3.000	0.154	3.000	0.774
	CAP	0.674	CAP	**
7	3.000	0.462	3.000	**
	3.500	0.649	3.500	0.275
	CAP	0.363	CAP	**
8	3.500	0.154	3.500	**
	4.000	0.400	4.000	**
	CAP	0.836	CAP	**

** Check with Miller Engineering.

How to order:

To order switches, enter a '9' in the Modified field of the cylinder model code. Describe the modification in notes by specifying:

1. EPS-5 or PEP-1 switch
2. Installation in head, cap, or both ends of the cylinder
3. Location in the head or cap (position #1, 2, 3, or 4) not occupied by a port or mounting

Miller H Series Hydraulic Cylinders

Determining the Proper Bore Size

To find the proper bore size for your cylinder, follow these simple steps:

1. In the table below, locate the column headed by the pressure at which you plan to operate the system.
2. Move down that column and find the force or thrust value which is the same as (or next higher value) that which the cylinder will be required to deliver.
3. On the same line, move across the table to the first column. The number shown there is most likely the bore size best suited to delivering the push stroke forces you require. Later checks can confirm whether this bore size is, in fact, the one which best serves your particular application needs.

Bore Size Estimation Table

Cylinder Bores in Inches	Piston Area Square Inches	THEORETICAL PUSH STROKE FORCES IN POUNDS												Oil Consumption Per Inch of Stroke in One Direction (GPI) Gals. Displaced
		PRESSURES OF OPERATING MEDIUM												
		50 PSI	60 PSI	80 PSI	100 PSI	200 PSI	250 PSI	500 PSI	750 PSI	1000 PSI	1500 PSI	2000 PSI	3000 PSI	
1½	1.767	88	106	141	177	353	442	884	1,325	1,767	2,651	3,534	5,301	.00765
2	3.142	157	189	251	314	628	786	1,571	2,357	3,142	4,713	6,283	9,426	.01360
2½	4.909	245	295	393	491	982	1,227	2,455	3,682	4,909	7,364	9,818	14,727	.0213
3¼	8.296	415	498	664	830	1,659	2,074	4,148	6,222	8,296	12,444	16,592	24,888	.0359
4	12.566	628	754	1,005	1,257	2,513	3,141	6,283	9,425	12,566	18,849	25,132	37,698	.0544
5	19.635	982	1,178	1,571	1,964	3,927	4,909	9,818	14,726	19,635	29,453	39,270	58,905	.0850
6	28.274	1,414	1,696	2,262	2,827	5,657	7,071	14,137	21,205	28,274	42,411	56,548	84,822	.1224
7	38.485	1,924	2,309	3,079	3,849	7,697	9,621	19,242	28,864	38,485	57,728	76,970	115,455	.1666
8	50.265	2,513	3,016	4,021	5,027	10,053	12,566	25,133	37,699	50,265	75,398	100,530	150,795	.2176
10	78.54	3,927	4,712	6,283	7,854	15,710	19,635	39,270	58,905	78,540	117,810	157,080	235,620	.3400
12	113.10	5,655	6,786	9,048	11,310	22,620	28,275	56,550	84,825	113,100	169,650	226,200	339,300	.4896
14	153.94	7,697	9,236	12,315	15,394	30,790	38,485	76,970	115,455	153,940	230,910	307,880	461,820	.6664
16	201.06	10,053	12,064	16,085	20,106	40,201	50,265	100,530	150,796	201,060	301,590	402,120	603,180	.8704
18	254.47	12,723	15,268	20,358	25,447	50,890	63,615	127,235	190,852	254,470	381,705	508,940	763,410	1.1016
20	314.16	15,708	18,850	25,133	31,416	62,830	78,540	157,080	235,620	314,160	471,240	628,320	942,480	1.3600

Thrusts for operating pressures not shown in the table may be calculated by multiplying the operating pressures by the piston areas.

Miller cylinders have efficiencies greater than 98% at 80 or more PSI on 4" or larger bores. As a result, power losses due to friction are usually negligible and need not be allowed for.

Pull Stroke Cylinder Bores and Forces

To find the force on the pull stroke, you need to know that: "the area on the rod end of the cylinder is less than the cylinder bore by the area of the rod."

To find the force on the pull stroke, you need to know the area of the rod. Example: For a five inch bore cylinder, the standard rod diameter is two inches.

Find two inches in the left most column in the chart below, move along to the right until you find the column headed by the pressure you will be working at. The number shown, is the value you deduct from the push stroke thrust in the chart above. The resultant is the force available for the pull stroke.

Should your pressure be different from those shown in the table, then use the following formula to calculate the pull force.

$$\text{Pull force} = (\text{Bore Area} - \text{Rod Area}) \times \text{Working Pressure.}$$

Piston Rod Diameter in Inches	Piston Rod Area Square Inches	THEORETICAL PULL STROKE FORCES IN POUNDS												Oil Consumption Per Inch of Stroke in One Direction (GPI) Gals. Displaced
		Deduct the following thrusts or consumptions corresponding to rod size from push stroke pressures or consumptions to determine pull stroke pressure or consumptions												
		PRESSURES OF OPERATING MEDIUM												
		50 PSI	60 PSI	80 PSI	100 PSI	200 PSI	250 PSI	500 PSI	750 PSI	1000 PSI	1500 PSI	2000 PSI	3000 PSI	
5/8	.307	15	18	25	31	61	77	154	230	307	461	614	921	.00133
1	.785	39	47	63	79	157	196	393	589	785	1,176	1,570	2,355	.0034
1 3/8	1.485	74	89	119	149	297	371	743	1,114	1,485	2,228	2,970	4,455	.00673
1 3/4	2.405	120	144	192	241	481	601	1,203	1,804	2,405	3,608	4,810	7,215	.01041
2	3.142	157	189	251	314	628	786	1,571	2,357	3,142	4,713	6,284	9,426	.01360
2 1/2	4.900	245	294	392	491	980	1,225	2,450	3,675	4,900	7,350	9,800	14,700	.0213
3	7.069	353	424	566	707	1,414	1,767	3,535	5,302	7,069	10,604	14,138	21,207	.0306
3 1/2	9.621	481	577	770	962	1,924	2,405	4,811	7,216	9,621	14,432	19,242	28,863	.0417
4	12.566	628	754	1,005	1,257	2,513	3,142	6,283	9,425	12,566	18,849	25,132	37,698	.0544
4 1/2	15.904	795	954	1,272	1,590	3,181	3,976	7,952	11,928	15,904	23,856	31,808	47,712	.0688
5	19.635	982	1,178	1,571	1,964	3,927	4,909	9,818	14,726	19,635	29,452	39,270	58,905	.0850
5 1/2	23.758	1,188	1,425	1,901	2,376	4,752	5,940	11,879	17,819	23,758	35,657	47,516	71,274	.1028
7	38.485	1,924	2,309	3,079	3,849	7,697	9,621	19,242	28,864	38,485	57,728	76,970	115,455	.1666
8	50.265	2,513	3,016	4,021	5,027	10,053	12,566	25,133	37,699	50,265	75,398	100,530	150,795	.2176
9	63.617	3,180	3,817	5,089	6,361	12,722	15,900	31,800	47,712	63,617	95,400	127,234	190,850	.2754
10	78.54	3,927	4,712	6,283	7,854	15,710	19,635	39,270	58,905	78,540	117,810	157,080	235,620	.3400

Operating Fluids and Temperature Range

Fluidpower cylinders are designed for use with pressurized air, hydraulic oil, and fire resistant fluids. In some cases special seals are required.

Standard Seals

Standard seals in a cylinder assembly are intended for use with fluids such as: air, nitrogen, mineral base hydraulic oil, water glycols, or MIL-H-5606 within the temperature range of -10°F (-23°C) to +160°F (+71°C). The individual seals may be nitrile (Buna-N), polyurethane, or PTFE.

High Temperature Seals

High temperature seals are intended for elevated temperature service or for some Phosphate Ester Fluids such as Houghto-Safe 1010, 1055, 1120; Fyrquel 150, 220, 300, 350; Mobil Pyrogard 42, 43, 53, and 55.

Note: In addition, high temperature seals can be used with fluids listed under Standard Seal service. However, they are not compatible with Phosphate Ester Fluids such as Skydrols.

High temperature seals can operate within a temperature range of -10°F (-23°C) to +250°F (+121°C). Fluorocarbon seals may be operated to +400°F (+204°C) with limited service life. For temperatures above +250°F (+121°C) the cylinder must be manufactured with non-studded piston rod thread. High temperature rod seals, rod wipers, and bushing O-rings are fluorocarbon. Piston seals and tube end seals are PTFE and piston seals are spring loaded. A spring loaded PTFE rod seal option is available for service to +450°F (+232°C).

PSCH (Position Sensing Cylinder H) Seals

PSCH seals consist of one filled PTFE dynamic piston seal with an elastomer expander underneath. PSCH piston arrangement normally consists of two wear rings mounted at the rear of the piston with the seal in front. This type of seal is virtually leak free under static conditions and can tolerate high pressure. The wear rings on the piston can also tolerate high side loads. The dynamic portion of the seal is bronze filled PTFE and is compatible with almost all types of fluids. However, carbon filled PTFE will provide better seal life when used with High Water Content Fluids. A nitrile expander will be provided unless high temperature seals are specified. In those cases the expander will be fluorocarbon. Note: It may be necessary to cycle the piston seals 40 or 50 times before achieving leakage free performance.

Warning

Optional studded piston rod end Style 6 has a threaded connection that is secured with temperature sensitive anaerobic adhesive. Cylinders specified with high temperature seals are assembled with anaerobic adhesive having a maximum temperature rating of +250°F (+121°C). Cylinders specified with all other seal compounds are assembled with anaerobic adhesive that has a maximum operating temperature rating +165°F (+74°C). These temperature limitations are necessary to prevent possible loosening of the threaded connections. Cylinders originally manufactured with standard seals (polyurethane, nitrile, & PTFE) that will be exposed to ambient temperatures above +165°F (+74°C) must be modified for higher temperature service. Contact the factory immediately and arrange for the stud to piston rod connection to be properly reassembled to withstand the higher temperature service.

Cast Iron Piston Rings

Cast iron rings are optional piston seals for H Series cylinders. They offer the widest operating conditions by tolerating high operating pressures, wide temperature range, and are compatible with most fluids. The only drawback of cast iron rings is that they allow a small amount of leakage. The leakage for a 4" bore cylinder, operating at 2000 psi, with mineral base hydraulic fluid will be less than 10 in.3/min. Leakage will increase as pressure, bore size and viscosity of the operating hydraulic fluid increases. For these reasons cast iron rings are not recommended when using water or High Water Content Fluids (HWCF).

Water Service

H Series hydraulic cylinders can be modified for water operation and are supplied with nickel-PTFE plated cylinder bore, head, cap, bushing, tie rods, tie rod nuts, cushion plungers, and piston; chrome-plated precipitation hardened stainless steel piston rod. When high water base fluids are the operating medium, hydraulic cylinders are usually supplied with high water base rod wiper and seals. Water and high water base fluid operated cylinders are best used on short stroke applications or where high pressure is applied only to clamp the load.

Warranty

Miller will warrant cylinders modified for water or high water content fluid service to be free of defects in materials or workmanship, but cannot accept responsibility for premature failure due to excessive wear caused by lack of lubricity or where failure is the result of corrosion, electrolysis or mineral deposits within the cylinder.

Miller H Series Hydraulic Cylinders

LDT Cylinders



Description

Miller Fluid Power Position Sensing Cylinders (PSC) with LDT magnetostrictive transducers provide versatile, high-response, and non-contacting position sensing.

The LDT consists of a conducting wire element in a waveguide internal to the cylinder rod. As the permanent magnet moves with the piston, an interaction of magnetic fields creates a waveguide twist which is converted from a strain pulse to an electrical output signal. The time interval from the pulse generator input to the conducting wire and the waveguide strain return pulse is the linear displacement measure. Position sensing is then determined by the digital or analog output voltage produced in the transducer electronics proportional to the magnet (piston) position.

Transducer Performance Specifications

	L* Series	R* Series
Resolution	Analog: Infinite Digital: Controller Dependent	Analog: 16 Bit Digital: Up to 0.00008"
Non-Linearity	$\pm 0.02\%$ or $\pm 0.002"$ whichever is greater	$< \pm 0.02\%$ or $\pm 0.0019"$ whichever is greater
Repeatability	Equal to Resolution	$< \pm 0.001\%$ or $\pm 0.000098"$ whichever is greater
Hysteresis	$< 0.0008"$	$< 0.0002"$
Update Time	≤ 1 ms (stroke dependent)	≤ 1 ms (stroke dependent)
Analog Adjustment	5%, Zero and Span	100%, Zero and Span

Design Features

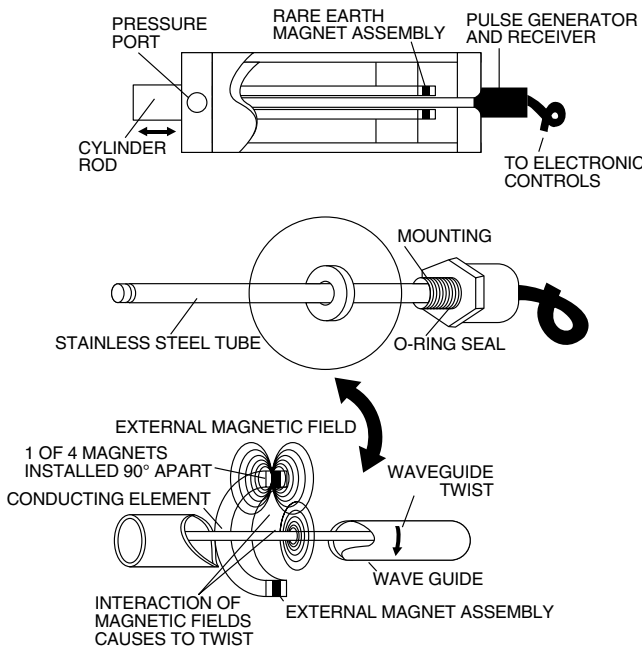

Unique design and state-of-the-art electronics allows for the integration of non-contacting transducers in heavy duty hydraulic cylinders. Infinite resolution, superior linearity, excellent stability, and "wear-free" operation provides enhanced system performance, maximum application accuracy, and improved productivity.

Wide range of transducer output signals interface with electronic modules and motion controllers for versatile system capability, multiplexing control schemes, and special application requirements.

Robust transducer electronics head is sealed and hardened for high vibration and shock use. The waveguide and wire is protected from possible damage by a stainless steel tube enclosure. Integral transducer mounting design provides ease of maintenance and reduced down-time.

Absolute position measurement ensures output voltage dependent on magnet (piston) position, thus calibrations are not required for electrical power on/off start-ups.

Cost competitive position sensing in a NFPA hydraulic cylinder with excellent price to performance ratio.

Standard Specifications

Enclosure/Housing Rating	IP67
Maximum Pressure	3,000 psi
Operating Temperature – Oil	-40° to 221°F
Operating Temperature – Ambient.....	-40° to 185°F
Supply Voltage	24 VDC strokes >60"; 13.5-26 VDC strokes to 60"
Power Consumption	100 mA
Shock Rating	100g Single Hit
Vibration Rating.....	5g 10-150 Hz
Maximum Stroke	120 inches
Minimum Bore Size	1 1/2 inches
Minimum Rod Diameter	1 inch

Transducer Electrical Options

Analog	Digital
0 to 10 VDC	PWM
-10 to +10 VDC	Start/Stop
10 to 0 VDC	SSI
4 to 20 mA	DeviceNet
20 to 4 mA	Canbus
Velocity	Quadrature

Miller H Series Hydraulic Cylinders

LRT Cylinders



How It Works

The Miller LRT is a uniquely designed position sensor that uses a resistive element and wiper assembly to provide an analog output signal of a cylinder's position. The LRT is a dual element type linear potentiometer with two independent elements mounted on either side of an anodized aluminum extrusion. The LRT operates as a voltage divider. This is done by shorting through the extrusion with the wiper assembly. The position of the wiper changes the resistive load proportional to its position along the cylinder stroke. The LRT is energized by applying a voltage across the unit, typically 10 VDC. As the resistive load changes with the cylinder stroke, the output voltage changes proportionally. The output voltage at the end point of the cylinder stroke is dictated by the input voltage applied across the device. The probe is mounted into the cylinder cap and inserted into the gun drilled piston rod. The compactness of the design only adds to the envelope dimensions of cylinders with 1-3/4" rods and smaller. Envelope dimensions of cylinders with larger rods are unaffected.

Design Features

- Available in strokes to 120".
- Unique, easy to apply cylinder position sensing system.
- Infinite resolution, high linearity and repeatability.
- Innovative, resistive element is made of conductive plastic.
- 3 pin Brad Harrison electrical connector available at any cap position not occupied by a port or mount.

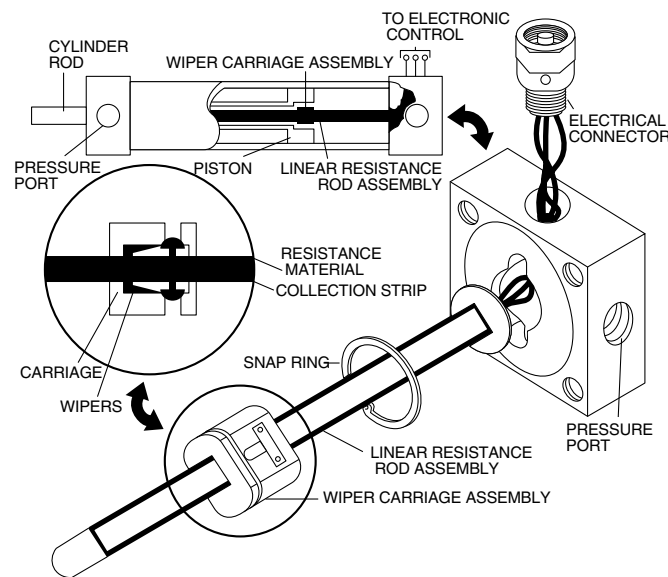

Transducer Performance Specifications

- Non-Linearity: Less than 0.1% of full scale up to 48" stroke. Less than 1.0% of full scale over 48" stroke.
- Repeatability: .001 inch
- Input Voltage: Nominal 5-50 Vdc
- Operating Temperature Range: -40°F to +160°F*
- Cylinder Stroke Length: Up to 120"
- Electrical Connector: Brad Harrison 3-pin micro connector interface at pos. #4 standard. (Unless occupied by a port or mount.)
- Total Resistance: 800Ω per inch of stroke (±20%) + end resistance.
- End Resistance: 800Ω
- Maximum Velocity: 30 inches per second
- Life Expectancy: Greater than 50 x 10⁶ cycles (Based on 1" stroke @ 10 ips)
- Fluid Medium: Petroleum based hydraulic fluids
- End Voltage Loss: (V source) x 400/stroke x 800
- Power Dissipation: supply voltage squared, divided by the total resistance.

The LRT requires a high impedance interface greater than 100K ohms. A maximum of 1 microamp should be required from the LRT.

The accuracy of a given feedback device is a composite of the following factors:

Temperature Coefficient: The shift in output due to temperature change. This is a combination of the effect of temperature on the cylinder, the transducer and the electronics.

These factors which are normally additive refer to the feedback device itself. The performance achieved by a given system depends on the various factors such as system stiffness, valve performance, friction, temperature variation, and backlash in mechanical linkages to the cylinder.

In the case of front flange mounted cylinders, the stretch of the cylinder due to hydraulic pressure changes may affect position repeatability and system performance.

*A high temperature option is offered to 300°F (consult factory).

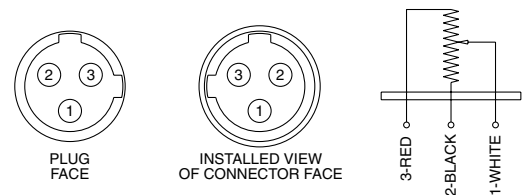

Pin Chart

Pin Number	On Cable	On LRT	Function
1	Green	White (wiper)	Output
2	Red w/Blk	Black (resistor base)	V-
3	Red w/White	Red (resistor to power)	V+

Miller H Series Hydraulic Cylinders

LDT Cylinders

LRT & LDT Mounting Configurations

Various types of transducers will affect the overall length of the cylinder. The length to be added to the cylinder is shown in the charts below for each of the designs and bore sizes. Pressure limitations apply for the different bore and rod combinations as shown below. If the particular mounting style you are using on the cylinder also has a pressure limitation, the lower of the two pressure limitations should be considered as the maximum rating of the cylinder. Optional manifolds are available for various circuits with proportional valves, etc. Contact the factory for special circuit requirements.

LRT cylinders can be furnished with any of the mounting styles shown in this catalog that do not interfere with the electrical connector in the cap. Standard position of the electrical connection is position #2 in the cap. Optional positions are #1, #3, or #4 except where the pressure port is located.

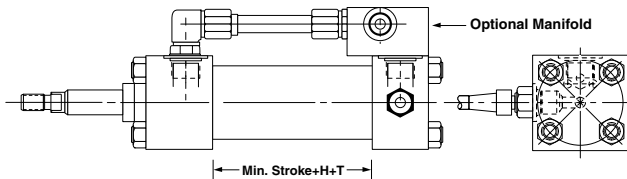

BORE SIZE	T
1½-4"	1"
5-8"	0"

PRESSURE LIMITATIONS

BORE	ROD	PRESSURE RATE (PSI)
1½	1	3000
	O.S.	2600
2	1	3000
	O.S.	2600
2½	1	1600
	O.S.	3000
3¼	1½	2000
	O.S.	3000
	1¾	2000
4	2	2000
	O.S.	3000
5	2½	2500
	O.S.	3000
6	3	2700
	O.S.	3000
7	3½	2600
	O.S.	3000
8	4	2600
	O.S.	3000

NOTES:

- *Min stroke is required for piping installation. May use stop tube to achieve this stroke.
- Manifold block will extend beyond cap rear face in some bore sizes. Contact the factory for those sizes.

BORE SIZE	* MIN STROKE REQ'D			
	D03	D05	D08	SERVO-VALVE
2"	3	—	—	3
2½	2½	—	—	2½
3¼	—	3½	5½	3½
4	—	3½	5¼	3½
5	—	3½	5¾	3½
6	—	3¼	5½	3¼
7	—	3¼	5½	3¼
8	—	2½	4½	2½

LDT cylinders have the transducer attached to the center rear face of the cap. Any mounting that does not interfere with the center face of the cap can be used with this standard design. The actual transducer length depends upon the manufacturer and can range between 3" and 4".

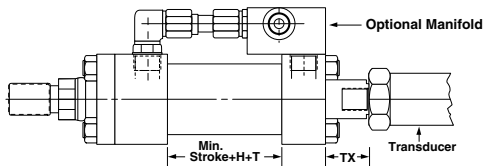

BORE SIZE	T
2-2½"	¼"
3¼-8"	0"

PRESSURE LIMITATIONS

BORE	ROD	PRESSURE RATE (PSI)
2	1½	3000
	O.S.	3000
2½	1½	3000
	O.S.	2000
3¼	1½	2000
	O.S.	3000
4	1¾	2800
	O.S.	3000
5	2	2000
	O.S.	3000
6	2½	2500
	O.S.	3000
7	3	2700
	O.S.	3000
8	3½	2600
	O.S.	3000

NOTES:

- *Min stroke is required for piping installation. May use stop tube to achieve this stroke.
- Manifold block will extend beyond cap rear face in some bore sizes. Contact the factory for those sizes.

BORE SIZE	* MIN STROKE REQ'D				
	D03	D05	D08	SERVO-VALVE	TX
2"	4	—	—	4	1¾
2½	3½	—	—	3½	1¾
3¼	—	4½	6½	4½	1¼
4	—	4½	6¼	4½	1¼
5	—	3½	5¾	3½	1¼
6	—	3¼	5½	3¼	1¾
7	—	3¼	5½	3¼	1¾
8	—	2½	4½	3¼	1¾

LDT cylinders used with cap clevis type mountings can be furnished with the intrinsic mounting design shown. This design can also be specified for purposes of protecting the transducer. Dimensions H and J can be found on the mounting pages of this catalog.

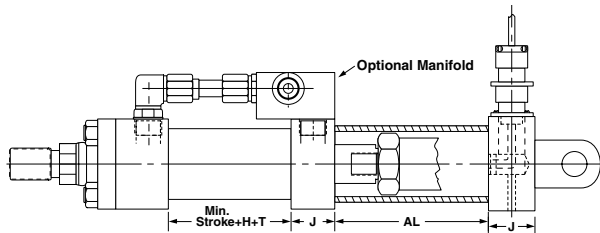

BORE SIZE	T
2-2½"	¼"
3¼-8"	0"

PRESSURE LIMITATIONS

BORE	ROD	PRESSURE RATE (PSI)
2	1½	3000
	O.S.	3000
2½	1½	3000
	O.S.	2000
3¼	1½	2000
	O.S.	3000
4	1¾	2800
	O.S.	3000
5	2	2000
	O.S.	3000
6	2½	2500
	O.S.	3000
7	3	2700
	O.S.	3000
8	3½	2600
	O.S.	3000

NOTES:

- *Min stroke is required for piping installation. May use stop tube to achieve this stroke.
- Manifold block will extend beyond cap rear face in some bore sizes. Contact the factory for those sizes.

BORE SIZE	* MIN STROKE REQ'D				
	D03	D05	D08	SERVO-VALVE	AL
2"	4	—	—	4	7½
2½	3½	—	—	3½	7½
3¼	—	4½	6½	4½	7½
4	—	4½	6¼	4½	7½
5	—	3½	5¾	3½	7½
6	—	3¼	5½	3¼	7½
7	—	3¼	5½	3¼	6½
8	—	2½	4½	2½	6½

Miller H Series Hydraulic Cylinders

LDT Cylinders Manifold Mounting Patterns

Bolt-on Manifolds

Miller H Series cylinders are available with Bolt-on Manifolds. Manifolds can be mounted on the head or cap end of a Miller H Series cylinder.

Available Bolt-on Manifold Valve Patterns

<p>Group A – Servo Manifold Height = 2.50</p> <p>Technical drawing of Group A Servo Manifold. Dimensions include: 1.46 (total width), .83 (width to center of hole A), 1.5/16 (width to center of hole B), .44 (width to center of hole T), 1.28 (height to center of hole A), 1.3/4 (height to center of hole B), 2.56 (total height), .50 (height to center of hole P), .87 (height to center of hole T), .44 (height to center of hole A), .44 (width to center of hole A), .88 (width to center of hole B), 1.75 (total width), 3/8 DIA. THRU 1 HOLE (A), 1/8 DIA. (hole diameter), 3/8 DIA. 3 HOLES (B-P-T), #12 SAE STRAIGHT TH'D. PORT - 3 PLACES, and 5/16-18 UNC-2B TH'D. 4 PLACES.</p>	<p>Servo Valve Mount Interchange Chart</p> <table border="1"> <thead> <tr> <th>Group A</th> <th>Group D</th> </tr> </thead> <tbody> <tr> <td>PARKER BD-15</td> <td>PARKER BD-30</td> </tr> <tr> <td>ATCHLEY 215A-XXX</td> <td>ATCHLEY 240-XXX</td> </tr> <tr> <td>MOOG 62 SERIES</td> <td></td> </tr> <tr> <td>MOOG 73 SERIES</td> <td>MOOG 78 SERIES</td> </tr> <tr> <td>MOOG 760 SERIES</td> <td></td> </tr> <tr> <td>PEGASUS M & MP SERIES</td> <td>PEGASUS 180L</td> </tr> <tr> <td></td> <td>PEGASUS 180R</td> </tr> <tr> <td>VICKERS SM4-20-X-X-10</td> <td>VICKERS SM4-40-X-X-10</td> </tr> </tbody> </table>	Group A	Group D	PARKER BD-15	PARKER BD-30	ATCHLEY 215A-XXX	ATCHLEY 240-XXX	MOOG 62 SERIES		MOOG 73 SERIES	MOOG 78 SERIES	MOOG 760 SERIES		PEGASUS M & MP SERIES	PEGASUS 180L		PEGASUS 180R	VICKERS SM4-20-X-X-10	VICKERS SM4-40-X-X-10
Group A	Group D																		
PARKER BD-15	PARKER BD-30																		
ATCHLEY 215A-XXX	ATCHLEY 240-XXX																		
MOOG 62 SERIES																			
MOOG 73 SERIES	MOOG 78 SERIES																		
MOOG 760 SERIES																			
PEGASUS M & MP SERIES	PEGASUS 180L																		
	PEGASUS 180R																		
VICKERS SM4-20-X-X-10	VICKERS SM4-40-X-X-10																		
<p>Group D – Servo Manifold Height = 2.50</p> <p>Technical drawing of Group D Servo Manifold. Dimensions include: 2.14 (total width), 1.75 (width to center of hole A), .81 (width to center of hole B), .87 (width to center of hole T), 2.14 (total height), 1.18 (height to center of hole P), .81 (height to center of hole T), .87 (height to center of hole A), 1.75 (height to center of hole B), 2.37 (height to center of hole T), 1.81 (width to center of hole A), 3.63 (total width), 5/8 DIA. THRU 1 HOLE (A), 3/16 DIA. (hole diameter), 5/8 DIA. 3 HOLES (B-P-T), #12 SAE STRAIGHT TH'D. PORT - 3 PLACES, and 5/16-18 UNC-2B TH'D. 4 PLACES.</p>	<p>Group J – NFPA D06 Manifold Height = 2.50</p> <p>Technical drawing of Group J NFPA D06 Manifold. Dimensions include: 5 (total width), 1.12 (height to center of hole A), 1.75 (height to center of hole B), 3.50 (total height), 1.1/8 (width to center of hole A), 2.75 (width to center of hole B), .58 DIA. THRU 1 HOLE (A), 3/4 (height to center of hole P), .68 (height to center of hole T), .38 (height to center of hole A), 2.38 (height to center of hole B), 2.19 (width to center of hole A), 5 (total width), 3/8-16 UNC-2B TH'D. 4 PLACES, #12 SAE STRAIGHT TH'D. PORT - (3) PLACES, and .58 DIA. X 1-1/2 DEEP 13 HOLES (B-P-T).</p>																		
<p>Group G – NFPA D03 Manifold Height = 2.00</p> <p>Technical drawing of Group G NFPA D03 Manifold. Dimensions include: 1.59 (total width), 1.5/32 (width to center of hole A), .80 (width to center of hole B), .35 (width to center of hole T), 1.1/2 (total height), 1.28 (height to center of hole P), .64 (height to center of hole T), .41 (height to center of hole A), .61 (height to center of hole B), 1.22 (height to center of hole T), .50 (width to center of hole A), .69 (width to center of hole B), 1.59 (total width), 1/4 DIA. THRU 1 HOLE (A), .16 DIA. (hole diameter), 1/4 DIA. 3 HOLES (B-P-T), #8 SAE STRAIGHT TH'D. PORT - 3 PLACES, and #10-24 UNC-2B TH'D. 4 PLACES.</p>	<p>Group K – NFPA D07 Manifold Height = 3.00</p> <p>Technical drawing of Group K NFPA D07 Manifold. Dimensions include: 5 (total width), 4.00 (width to center of hole A), 1/2 (width to center of hole B), 3.47 (width to center of hole T), 2.59 (width to center of hole P), 1.1/8 (height to center of hole A), .50 (height to center of hole T), .06 (height to center of hole A), .56 (height to center of hole B), 2.19 (height to center of hole T), 2.75 (height to center of hole P), 2.81 (height to center of hole T), 5 (total height), 1/4 DIA. X 5/8 DEEP 2 HOLES (X-Y), 1/4 DIA. 3 HOLES (B-P-T), 3/8-16 UNC-2B TH'D. - 4 PLACES, .16 DIA. 2 PLACES, 1/4-20 UNC-2B TH'D. 2 PLACES, 1.72 (width to center of hole A), 1.34 (width to center of hole B), 1.97 (width to center of hole T), 3.02 (width to center of hole P), 11/16 DIA. THRU 1 HOLE (A), #4 SAE STRAIGHT TH'D. PORT - 2 PLACES, #16 SAE STRAIGHT TH'D PORT - 3 PLACES, and 11/16 DIA. X 1-5/16 DEEP 3 HOLES (B-P-T).</p>																		
<p>Group H – NFPA D05 Manifold Height = 2.50</p> <p>Technical drawing of Group H NFPA D05 Manifold. Dimensions include: 2.36 (total width), 1.46 (width to center of hole A), .81 (width to center of hole B), .53 (width to center of hole T), 1.68 (total height), .97 (height to center of hole A), .44 (height to center of hole B), .59 (height to center of hole T), .84 (height to center of hole P), 2.36 (total width), 7/16 DIA. THRU 1 HOLE (A), 7/16 DIA. 3 PLACES (B-P-T), #12 SAE STRAIGHT TH'D. PORT - 3 PLACES, and 1/4-20 UNC-2B TH'D. 4 PLACES.</p>	<p>Group M – NFPA D08 Manifold Height = 3.50</p> <p>Technical drawing of Group M NFPA D08 Manifold. Dimensions include: 6 (total width), 3.97 (width to center of hole A), 3.03 (width to center of hole B), .69 (width to center of hole T), 2.88 (width to center of hole P), .69 (width to center of hole A), 1.16 (width to center of hole B), 2.09 (width to center of hole T), 3.72 (width to center of hole P), 4.44 (width to center of hole A), 5.13 (width to center of hole B), 6 (total height), 7/16 DIA. X 2" DEEP 2 HOLES (X-Y), 9/32 DIA. 2 PLACES, 7/16 (hole diameter), #20 SAE STRAIGHT TH'D PORT - 3 PLACES (B-P-T), 3/97 (height to center of hole A), 29/32 DIA. THRU (A), 1/2-13 UNC-2B TH'D 6 PLACES, 29/32 DIA. X 2" DEEP 3 HOLES (B-P-T), 1/4-20 UNC-2B TH'D. 4 PLACES, .19 (width to center of hole A), 2.15/16 (width to center of hole B), .75 (width to center of hole T), 3.63 (width to center of hole P), 7/16 (hole diameter), and #4 SAE STRAIGHT TH'D PORT - 2 PLACES.</p>																		

Note: On NFPA D05 "X" and "Y" ports are not standard. If required, please contact the Miller Fluid Power.

Miller H Series Hydraulic Cylinders

Feedback Device Dimensions LD and RD Housings

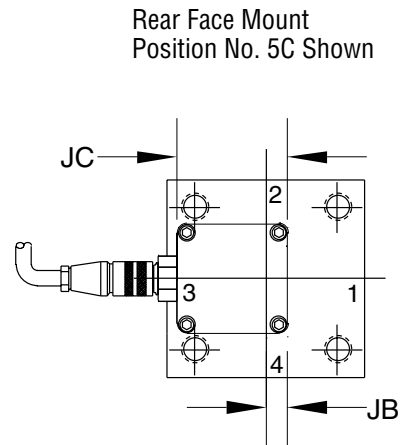
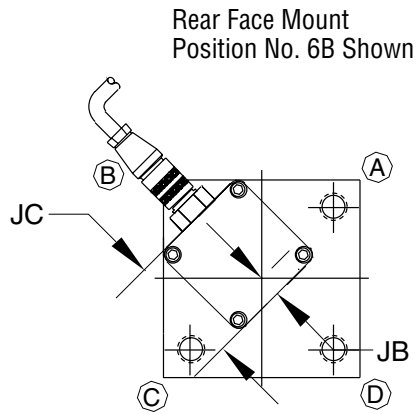
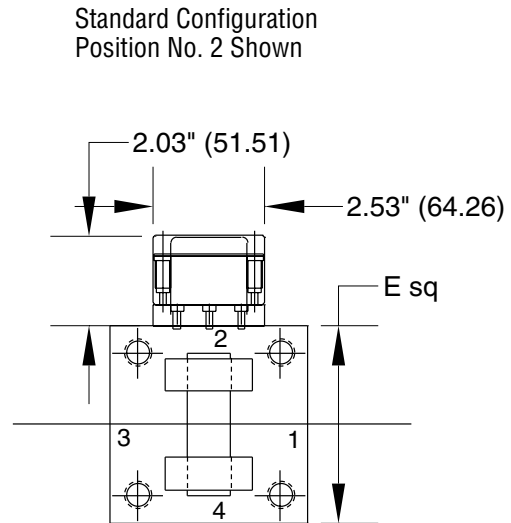
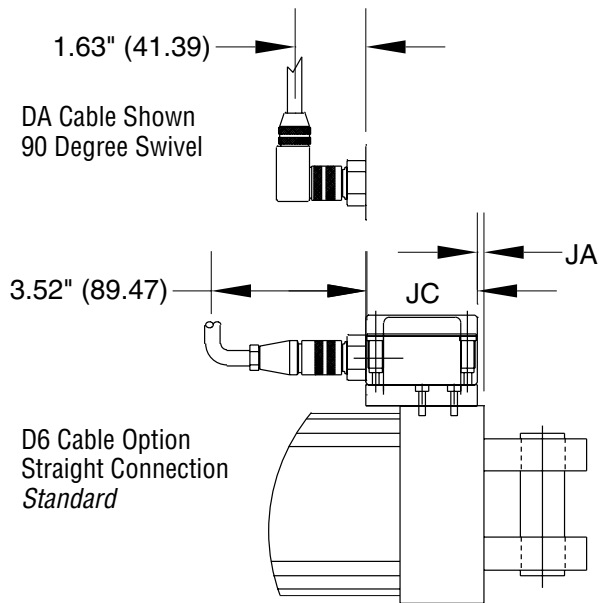

Transducer	LD and RD Transducer	LD and RD Transducer	LD Transducer	RD Transducer
Bore Sizes	Dimension "JA"	Dimension "JB"	Dimension "JC"	
1.50"	0.13"	N/A	2.53"	4.00"
2.00"	0.13"	N/A	2.53"	4.00"
2.50"	0.13"	N/A	2.53"	4.00"
3.25"	0.06"	N/A	2.53"	4.00"
4.00"	0.06"	0.52"	2.53"	4.00"
5.00"	0.06"	0.52"	2.53"	4.00"
6.00"	0.03"	0.52"	2.53"	4.00"
7.00"	0.03"	0.52"	2.53"	4.00"
8.00"	0.03"	0.52"	2.53"	4.00"

Notes:

1. Enclosure position number 5 available with tie rods threaded into cap on 1-1/2" to 3-1/4" bore sizes.
2. Enclosure position number 6 available with tie rods threaded into cap on 1-1/2" to 6" bore sizes.

Miller H Series Hydraulic Cylinders

Cylinder Pressure Ratings Oversize Ports

Application Data

The proper application of a fluid power cylinder requires consideration of the operating pressure, the fluid medium, the mounting style, the length of stroke, the type of piston rod connection to the load, thrust or tension

loading on the rod, mounting attitude, the speed of stroke, and how the load in motion will be stopped. Information given here provides pressure rating data for H Series hydraulic cylinders.

Hydraulic Cylinders (Heavy-Duty)

Standard operating fluid – clean filtered hydraulic oil. Pressure ratings for H Series heavy-duty cylinders are shown in the following table.

Pressure ratings

H Series hydraulic cylinders are recommended for pressures to 3000 psi for heavy-duty service with hydraulic oil. The 4:1 design factor ratings shown are based on tensile strength of pressure envelope material and are for standard and first oversize rod diameter only. The pressure envelope components are the tube, piston and rod connection, and tie rod and nut connection. Additional oversize rods for a given bore will have the same rating as the first oversize rod. The rating is conservative for continuous severe applications. Design factors at other pressures can be calculated from this rating. In addition, mounting styles, stroke, etc., should be considered because of the limiting effect they may have on these ratings.

**H Series Hydraulic Cylinders
Maximum Pressure Ratings**

Bore Size (inches)	Rod Diameter (inches)	4:1 Design Factor (Tensile) (PSI)	Heavy-Duty* Service (PSI)
1½	5/8	1920	3000
	1	3000	3000
2	1	2980	3000
	1¾	2980	3000
2½	1	2175	3000
	1¾	3000	3000
3¼	1¾	2415	3000
	1¾	3000	3000
4	1¾	2560	3000
	2	2700	3000
5	2	2440	3000
	2½	2965	3000
6	2½	2645	3000
	3	2645	3000
7	3	2555	3000
	3½	2555	3000
8	3½	2490	3000
	4	2490	3000
10	4½	2615	3000
	5	2615	3000
12	5½	2675	3000
	7	2675	3000
14	7	2325	3000
	8	2325	3000
16	8	2290	3000
	9	2290	3000
18	9	2675	3000
	10	2675	3000
20	10	2430	3000

*See individual mounting pages for reduced heavy-duty service ratings.

Welded Oversize Ports

To accommodate large pump volumes and minimize pressure drops, Miller hydraulic cylinders are available in most models with oversize ports that are welded half pipe couplings.

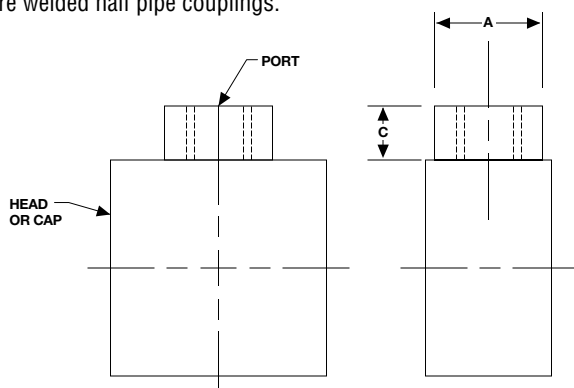

NPT PORT	A	C
¾-14	1¾	1
1-11½	1¾	1¾
1¼-11½	2¼	1¾
1½-11½	2½	1¾
2-11½	3	1¾
2½-8	3¾	1¾
3-8	4¼	2¼
3½-8	4¾	2¼

SAE Port Dash #	Thread	A	C
(-6)	¾-18	.875	.700
(-8)	¾-16	1.125	.850
(-10)	¾-14	1.375	.950
(-12)	1¼-12	1.375	.950
(-14)	1¾-12	1.625	1.100
(-16)	1¾-12	1.625	1.100
(-20)	1¾-12	2.125	1.100
(-24)	1¾-12	2.500	1.100
(-32)	2½-12	3.000	1.200

Miller H Series Hydraulic Cylinders

Stop Tubes for Long Push Stroke Cylinders

The use of a stop tube is a generally accepted and preferred method for reducing piston and bearing loads on long push stroke cylinders and, additionally, for preventing jack-knifing or buckling of horizontally mounted, long stroke cylinders on push stroke. Stop tubes are more effective, less costly, and lighter in weight than oversize piston rods.

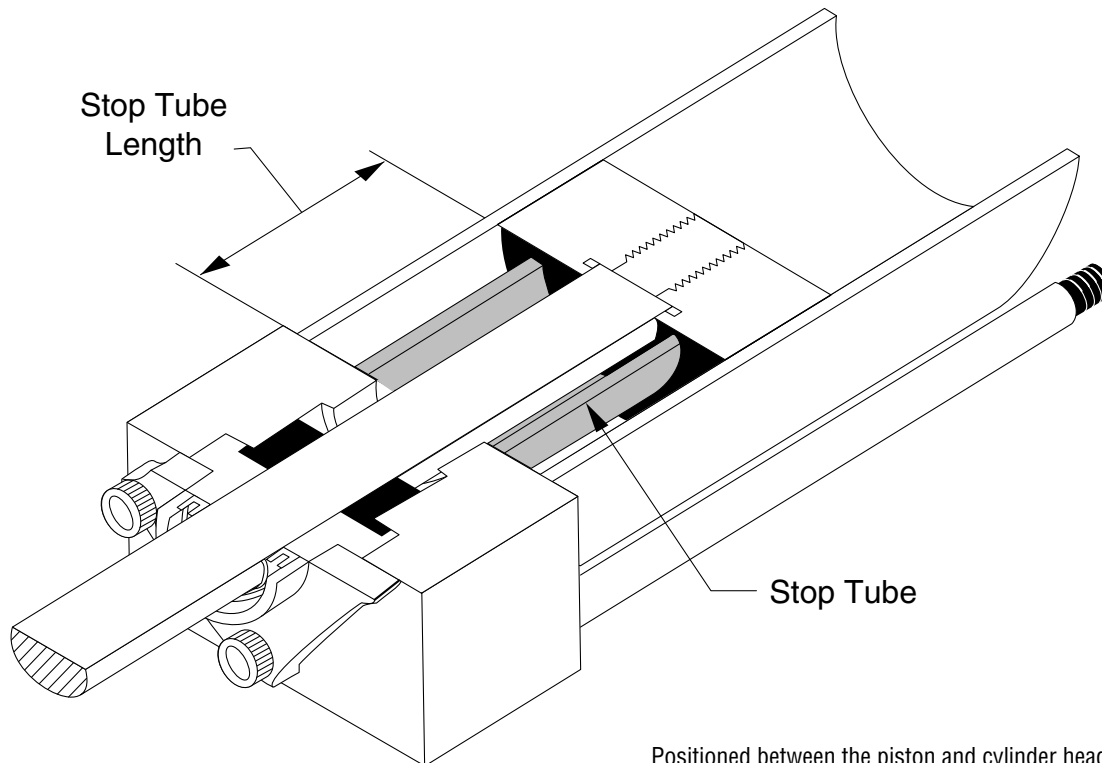

Positioned between the piston and cylinder head, a stop tube restricts the extended position of the rod so that the added distance between the piston and bushing results in less strain, wear, and bearing load.

Determining the Length and Need For Stop Tube

Follow these simple steps to determine whether your cylinder requires a stop tube, and, if so, how long it should be.

1. Examine the groups of cylinders illustrated on Page 75 and determine which, if any, of the mounting configurations corresponds to your cylinder application and model number.
2. If your cylinder mounting style corresponds to any of those in Group A, then no stop tube is required. But, if cylinder operates on push stroke, an oversize rod may be required and you should check the following page. If your cylinder is like one of those in Group B, then a stop tube is

recommended and you should proceed to Step 3. If your cylinder is similar to one of the Group C illustrations, then you should calculate the turning moments and loads between piston and rod bushing to insure that they are not excessive. Weight of fluid must be included on large dia. or long stroke cylinders. For assistance on this, contact Miller Fluid Power Application Engineering Dept. Next, continue on to Step 3 to determine the length of stop tube needed.

Miller H Series Hydraulic Cylinders

3. Referring to the illustration which corresponds to your cylinder application, determine the value of "L". Be certain to include the thickness of the cylinder head, cap and piston assembly plus twice the length of the cylinder stroke. Then go down the first column of the Stop Tube Table and find the range which encompasses that value of "L". The number shown to the right in the second column is the length of stop tube your cylinder requires.

4. Add the stop tube length to your "L" dimension to obtain an "Adjusted L Dimension". This dimension will be used in the procedures on the following page to determine whether your cylinder requires an oversize piston rod in addition to the stop tube except models 53, 61, 63, 65, 67, 81 & 89.

Stop Tube Table

"L" (inches)	Stop Tube Length (inches)
0-40	0
41-50	1
51-60	2
61-70	3
71-80	4
81-90	5
91-100	6
101-110	7
111-120	8
121-130	9
131-140	10
141-150	11
151-160	12
161-170	13

Note: 'L' or 'D' are calculated from mounting point with rod extended.

For longer strokes consult factory.

Group A

With piston rod extended. To be checked for rod diameter only. Stop tube not required.

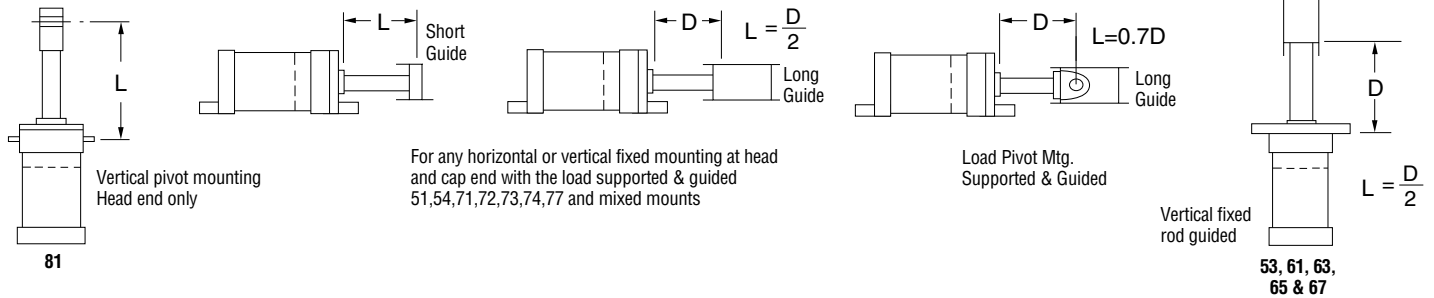

Group B

To avoid rod buckling or cylinder jackknifing, check for stop tube and rod diameter requirements with piston rod extended. Use cylinder dimensional charts. No stop tube required if cylinder operates on pull stroke only.

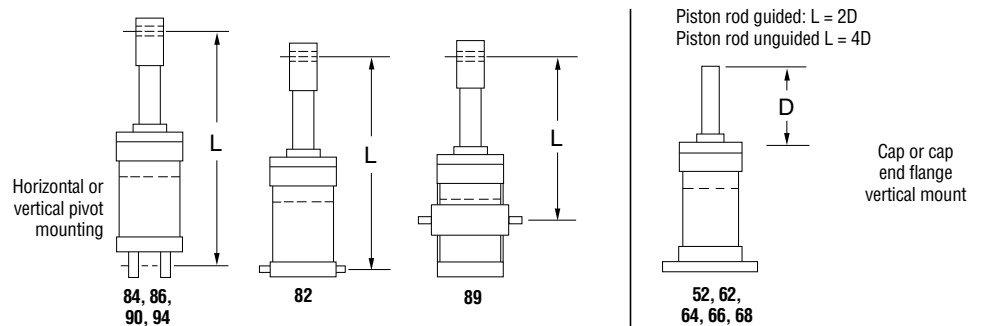

Group C

To be checked for Stop tube length and piston rod diameter to eliminate buckling or jackknifing with piston rod extended.

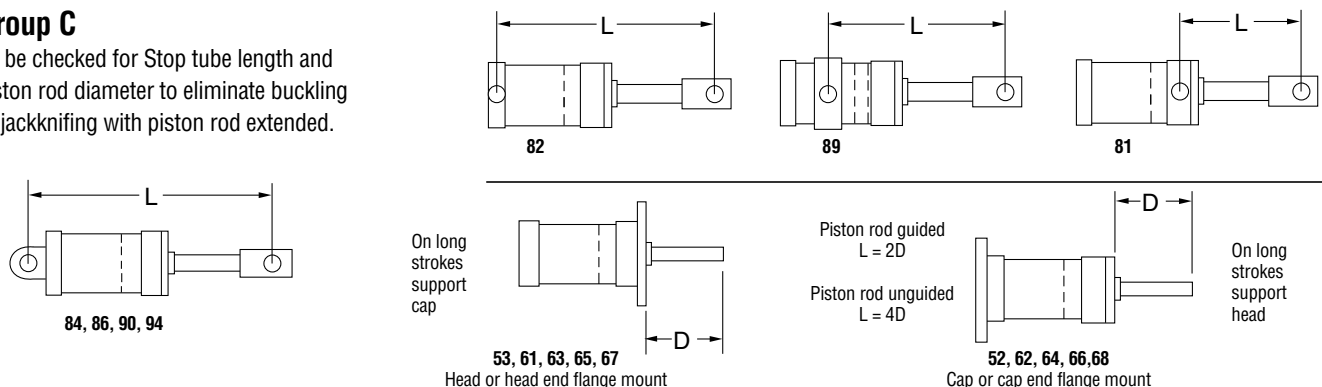

Miller H Series Hydraulic Cylinders

Oversize Piston Rods for Column Strength on Long Push Stroke Cylinders

Cylinder applications requiring column strength or long cylinder push strokes may need oversize piston rods.

However, Miller Fluid Power cautions against depending upon the higher rigidity of oversize rods to absorb or reduce side loading. Actually, the greater flexibility of a smaller standard diameter rod transmits less side loading back to the piston rod bushing. It is important to use the correct rod diameter based on the various factors involved in your application. Oversize rods, when not needed, merely add to the cylinder price and require longer delivery.

Standard rod diameters are recommended for all pull stroke cylinders. To determine the correct rod diameter for a push stroke application, follow these simple steps.

1. Referring to the Group A through C illustrations on the previous page, determine the value of "L" for your cylinder, or use the "Adjusted L Dimension" calculated in Step 4 on that page.
2. In the Oversize Piston Rod Table, find in the first column your cylinder thrust value which was previously determined.
3. Move across the table to the right end and in the same row locate your "L" or "Adjusted L Dimension". If the exact value is not shown, continue to the next larger number.
4. Go to the top of the column and you will find the correct rod diameter for your cylinder application.

Oversize Piston Rod Table

Thrust in lbs.	PISTON ROD DIAMETER															
	5/8"	1"	1 3/8"	1 3/4"	2"	2 1/2"	3"	3 1/2"	4"	4 1/2"	5"	5 1/2"	7"	8"	9"	10"
250	43	94	146													
400	37	83	134	186												
700	30	68	118	168	202	275										
1,000	27	60	105	155	190	257	330									
1,400	24	53	92	142	174	244	308	385								
1,800	23	48	82	127	160	230	296	366	440							
2,400	19	45	75	114	145	213	281	347	415	488						
3,200	16	41	67	103	130	194	261	329	400	461						
4,000	13	38	63	94	119	175	240	310	378	446						
5,000	9	34	60	87	110	163	225	289	360	426	494					
6,000	5	30	56	82	102	152	208	274	342	410	476					
8,000	5	26	50	76	93	137	188	245	310	375	447					
10,000	4	21	45	70	89	125	172	222	279	349	412	482				
12,000	3	17	41	65	84	118	155	210	269	326	388	454				
16,000		9	34	57	75	110	142	188	235	292	350	420				
20,000		8	28	52	68	103	136	172	218	270	326	385				
30,000		6	12	39	55	87	120	156	189	230	285	330				
40,000			11	22	43	74	108	142	177	210	248	294				
50,000			9	15	30	66	96	130	165	200	234	269	408			
60,000				14	18	57	88	119	154	190	225	256	384			
80,000				12	16	36	71	104	137	170	204	240	336			
100,000					14	22	57	90	120	154	189	222	324	400		
120,000					12	21	45	77	108	140	175	207	313	377		
140,000						19	27	64	98	128	160	194	301	365		
160,000						17	26	47	86	118	148	182	279	350	421	
200,000						14	23	31	67	98	131	161	260	330	402	
250,000							19	28	36	72	109	141	236	301	375	
300,000								25	34	42	86	120	212	281	351	420
350,000								22	31	39	52	100	195	261	328	396
400,000								19		37	45	77	182	241	309	374
500,000										32	41	49	152	212	274	341
600,000											37	45	114	183	247	310
700,000											32	41	70	162	221	280
800,000												37	63	118	197	260
900,000													60	82	168	237
1,000,000													57	73	115	212
1,200,000													51	68	84	170
1,400,000													45	62	79	105
1,600,000														57	74	91
1,800,000															70	86
2,000,000															65	82

Values of (L) for slenderness ratios (slenderness ratio = length ÷ radius of gyration = 4 x length ÷ piston rod diameter) greater than 50 have a safety factor of 5 to 1. Values of (L) for slenderness ratios less than 50 are based on compressive strength only (S = thrust ÷ rod area) and have safety factors between 2.4-1 and 5-1 which are directly proportional to (L). (i.e. the greater the value of (L) the greater the safety factor).

Miller H Series Hydraulic Cylinders

Non-Sag Piston Rods for Long Stroke, Horizontally Mounted Cylinders

Miller patented non-sag piston rods reduce bushing wear on long stroke, horizontally mounted cylinders. Keyed in your machinery in their prestressed position, to prevent rotation non-sag piston rods remain

straight without the deflections or sag of ordinary rods. Using non-sag piston rods on long stroke cylinders prevents overloading of rod bushing and piston and the resulting costly damage.

Determining If Your Cylinder Requires A Non-Sag Rod

Miller cylinders have a commercial straightness of 0.002 inches per foot of length. The gravity-induced rod sag for horizontally mounted cylinders is given in the Rod Deflection Table. To determine if this sag is excessive, follow these simple directions.

1. After having checked the rod for column strength on the previous page, find your rod diameter in the first column of the table.
2. Read across the table to the column headed by the length of the rod between supports when rod is fully extended, and find the sag in inches which can be expected with a standard rod.
3. If this figure lies within the shaded area of the table, you should specify a non-sag rod.

Rod Deflection Table

This table shows the deflections in inches of ordinary piston rods at center of span. Length of piston rod between supports is in feet. Rod diameter and sag are in inches.

Dia. Piston Rod	Weight In Lbs. PER FT.	LENGTH OF PISTON RODS (IN FEET) BETWEEN SUPPORTS WITH RODS EITHER EXTENDED OR RETRACTED																						
		5	6	7	8	9	10	11	12	13	14	15	16	17	18	19	20	21	22	23	24			
5/8	1.043	.065	.134	.255	.425	.675	1.020	1.500	5/8" rod not available in non-sag															
1	2.670	.030	.053	.099	.166	.265	.385	.580	.850	1.160	1.570													
1 1/8	5.049	.013	.028	.053	.088	.136	.212	.310	.450	.617	.830	1.100	1.418											
1 1/4	8.178	.008	.017	.033	.054	.086	.130	.192	.278	.380	.515	.680	.870	1.115	1.400									
2	10.680	.006	.013	.025	.042	.066	.101	.148	.212	.290	.390	.525	.670	.850	1.072	1.330								
2 1/2	16.690	.004	.0085	.016	.027	.042	.064	.094	.136	.186	.240	.335	.430	.545	.685	.856	1.040	1.286	1.520					
3	24.030		.006	.011	.018	.029	.045	.065	.094	.129	.175	.231	.296	.380	.475	.590	.722	.884	1.060	1.270	1.500			
3 1/2	32.710		.0043	.008	.014	.022	.033	.048	.069	.095	.128	.170	.218	.278	.350	.435	.530	.650	.780	.930	1.100			
4	42.730			.006	.010	.016	.025	.037	.053	.073	.098	.130	.166	.213	.267	.333	.405	.500	.595	.715	.844			
4 1/2	54.070			.005	.0082	.013	.020	.029	.043	.057	.078	.103	.132	.168	.212	.262	.320	.395	.470	.565	.670			
5	66.760				.0066	.0106	.016	.023	.034	.046	.063	.083	.107	.136	.171	.213	.260	.320	.380	.460	.545			
5 1/2	80.780				.0055	.0087	.013	.019	.028	.038	.052	.068	.088	.122	.142	.176	.215	.263	.315	.390	.450			
7	130.8					.054	.0083	.0121	.172	.0237	.0319	.0421	.0545	.0695	.0873	.1084	.1331	.1618	.1949	.2329	.2761			
8	170.9						.0063	.0093	.0132	.0182	.0244	.0322	.0417	.0532	.0669	.0830	.1019	.1239	.1493	.1783	.2114			
9	216.3						.0050	.0073	.0104	.0143	.0193	.0254	.0330	.0420	.0528	.656	.0805	.0979	.1179	.1409	.1670			
10	267.0							.0059	.0084	.0116	.0156	.0206	.0267	.0340	.0428	.0531	.0652	.0793	.0955	.1141	.1353			

Standard Cylinder

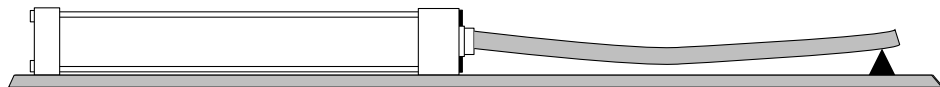

Non-Sag Rod Miller Cylinder

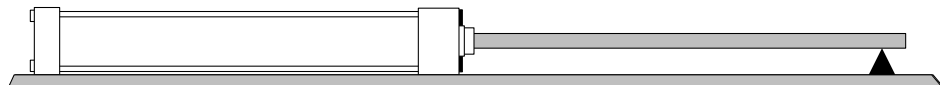

Miller H Series Hydraulic Cylinders

Keying and Pinning Foot Mounting Cylinders

Foot mount cylinders should be keyed or pinned on the appropriate end to eliminate shearing loads on mounting bolts.

Cylinders with integral key mounts may be used where keyways can be cut in a machine member. This type of mounting accommodates shear loads, provides accurate alignment of the cylinder, and simplifies installation and servicing.

Only one end of a cylinder should be keyed to the machine. If both ends are keyed, there will be no cylinder elasticity to assist in absorbing shocks.

Locating pins may be used instead of shear keys to help take shear loads and to assure proper cylinder alignment. As with keys, cylinders

should be pinned at either end (but not both ends). Contrary to common die design practices, cylinders should never be pinned across corners. To do so can result in severe warping under operating pressures and temperatures.

Pivoted mounts should have the same type of pivots at both the cylinder body and rod end. If a simple pivot pin mount is used, the pivot pin axes at each end should be parallel. Trunnion mounts are generally designed to resist only shear loads. Therefore, self-aligning mounts should not be used to support the trunnions, otherwise bending forces can also be set up.

Keying a Cylinder

RIGHT

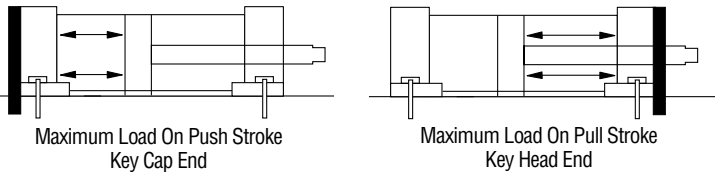

WRONG

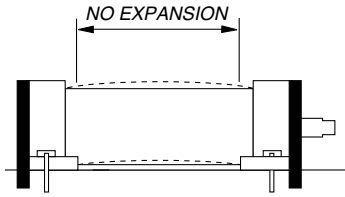

Pinning a Cylinder

RIGHT

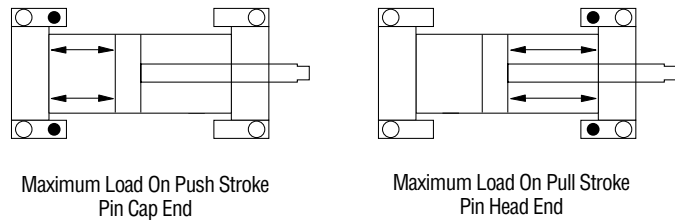

WRONG

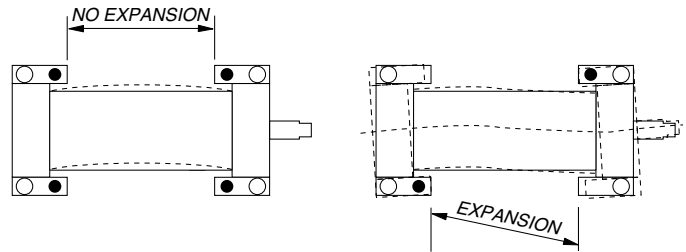

“K” Retainer-Key Extension

Provides Models 71,72,74, and 77 with Max. Mounting Rigidity Without Pins or Welded Keys

For a rugged mounting that cannot shift under maximum loads, the “K” retainer-key extension extends the rod retainer plate so that it slips into a slot milled in

machine's mounting surface. “K” retainer thickness is dimension “F*” $\begin{matrix} -0.0140 \\ -0.0145 \end{matrix}$. Extension = $\frac{F}{2}$. Available as option at additional cost.

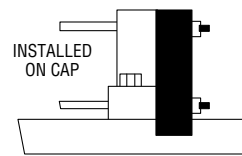
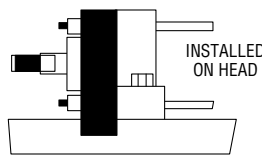
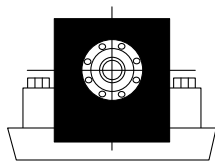

*See respective mounting pages for dimensions — Square Retainer Section

Miller H Series Hydraulic Cylinders

Parts List and Seal Kits

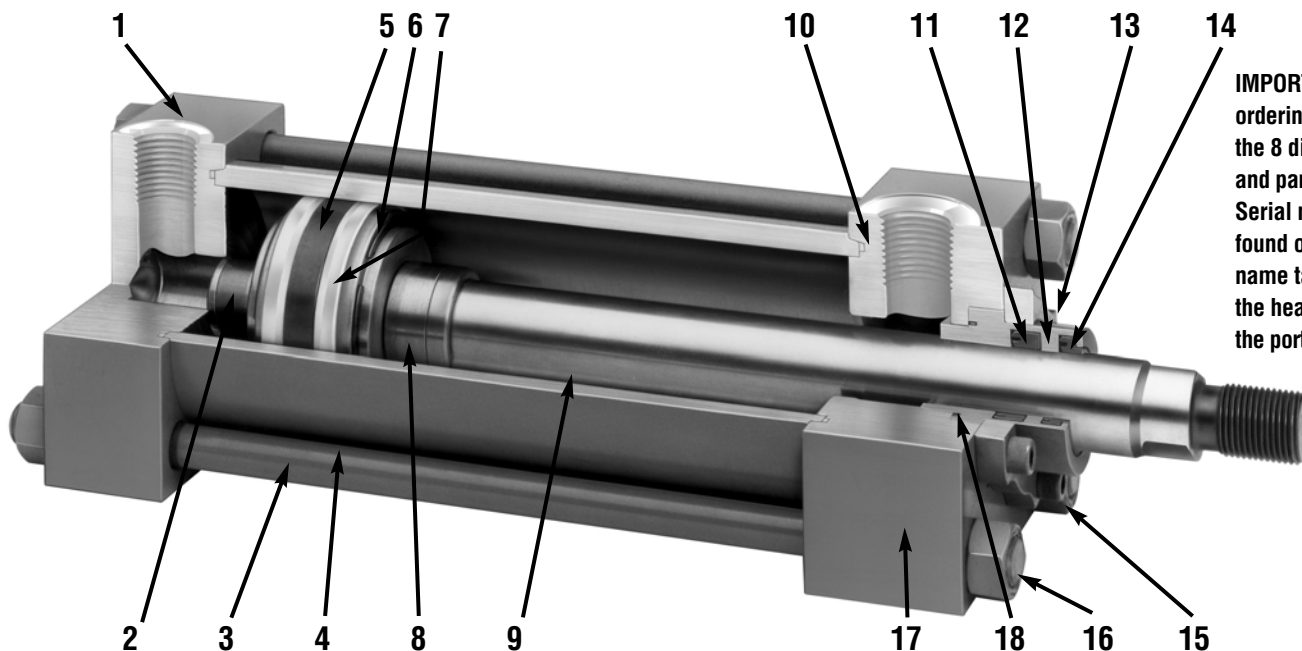

IMPORTANT: When ordering parts, specify the 8 digit serial number and part name as shown. Serial number can be found on the cylinder name tag or stamped on the head and cap near the ports.

Rod Diameter	Bolted Bushing Rod Seal Kit Part # 11, 12, 13, 14, 18	Retainer Bushing Rod Seal Kit Part # 11, 12, 14, 18
5/8	051-KR075-63	051-KR074-63
1	051-KR075-100	051-KR074-100
1 3/8	051-KR075-138	051-KR074-138
1 3/4	051-KR075-175	051-KR074-175
2	051-KR075-200	051-KR074-200
2 1/2	051-KR075-250	051-KR074-250
3	051-KR075-300	051-KR074-300
3 1/2	051-KR075-350	051-KR074-350
4	051-KR075-400	051-KR074-400
4 1/2	051-KR075-450	051-KR074-450
5	051-KR075-500	051-KR074-500
5 1/2	051-KR075-550	051-KR074-550
7	051-KR075-700	
8	051-KR075-800	
9	051-KR075-900	
10	051-KR075-1000	

- 1. Cap
- 2. Cap End Cushion Plunger
- 3. Tie Rod (4)
- 4. Tube
- 5. Wear Ring
- 6. Piston
- 7. Piston Seal (2)
- 8. Rod End Cushion Plunger
- 9. Piston Rod
- 10. Tube End Seal (2)
- 11. Rod Seal
- 12. Bushing
- 13. Bushing Retainer
- 14. Rod Wiper
- 15. Socket Head Cap Screws
- 16. Tie Rod Nuts
- 17. Head
- 18. Bushing O-Ring
- 19. Piston Rings (4 Required)
- 20. Pressure Ring for Piston Seal (2 Req'd)
- 21. Wave Spring for Piston Seal (2 Req'd)

Bore	Bore Kit Part # 5, 7, 10
1 1/2	171-KB001-0150
2	171-KB001-0200
2 1/2	171-KB001-0250
3 1/4	171-KB001-0325
4	171-KB001-0400
5	171-KB001-0500
6	171-KB001-0600
7	171-KB001-0700
8	171-KB001-0800
10	171-KB001-1000
12	171-KB001-1200
14	171-KB001-1400
16	171-KB001-1600
18	171-KB001-1800
20	171-KB001-2000

Note: The most popular sizes are shown. The larger bore and rod sizes are in stock, please call. For complete installation & maintenance request File No. 8535.

PISTON RINGS	
Bore	#19 (4 Required)
1 1/2	052-PS027-150
2	052-PS027-200
2 1/2	052-PS027-250

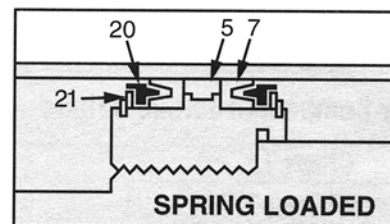

Spring Loaded Teflon Cup Seals required for temperatures in excess of 160°F or below -20°F.

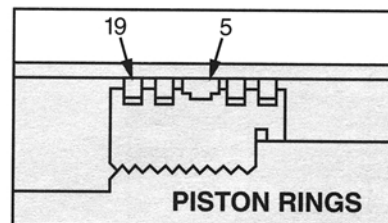

Piston ring construction is standard on the following small bore, max. oversize rod cylinders. 1 1/2" bore 1" rod, 2" bore 1 3/8" rod & 2 1/2" bore 1 3/4" rod.

Storage

At times cylinders are delivered before a customer is ready to install them and must be stored for a period of time. When storage is required the following procedures are recommended.

1. Store the cylinders in an indoor area which has a dry, clean and noncorrosive atmosphere. Take care to protect the cylinder from both internal corrosion and external damage.
2. Whenever possible cylinders should be stored in a vertical position (piston rod up). This will minimize corrosion due to possible condensation which could occur inside the cylinder. This will also minimize seal damage.
3. Port protector plugs should be left in the cylinder until the time of installation.
4. If a cylinder is stored full of hydraulic fluid, expansion of the fluid due to temperature changes must be considered. Installing a check valve with free flow out of the cylinder is one method.

Installation

1. Cleanliness is an important consideration, and Miller cylinders are shipped with the ports plugged to protect them from contaminants entering the ports. These plugs should not be removed until the piping is to be installed. Before making the connection to the cylinder ports, piping should be thoroughly cleaned to remove all chips or burrs which might have resulted from threading or flaring operations.
2. Cylinders operating in an environment where air drying materials are present such as fast-drying chemicals, paint, or weld splatter, or other hazardous conditions such as excessive heat, should have shields installed to prevent damage to the piston rod and piston rod seals.
3. Proper alignment of the cylinder piston rod and its mating component on the machine should be checked in both the extended and retracted positions. Improper alignment will result in excessive rod bushing and/or cylinder bore wear. On fixed mounting cylinders attaching the piston rod while the rod is retracted will help in achieving proper alignment.

Mounting Recommendations

1. Always mount cylinders using the largest possible high tensile alloy steel socket head screws that can fit in the cylinder mounting holes and torque them to the manufacturer's recommendations for their size.
2. Side-Mounted Cylinders – In addition to the mounting bolts, cylinders of this type should be equipped with thrust keys or dowel pins located so as to resist the major load.
3. Tie Rod Mounting – Cylinders with tie rod mountings are recommended for applications where mounting space is limited. The standard tie rod extension is shown as BB in dimension tables. Longer or shorter extensions can be supplied. Nuts used for this mounting style should be torqued to the same value as the tie rods for that bore size.
4. Flange Mount Cylinders – The controlled diameter of the rod bushing extension on head end flange mount cylinders can be used as a pilot to locate the cylinders in relation to the machine. After alignment has been obtained, the flanges may be drilled for pins or dowels to prevent shifting.
5. Trunnion Mountings – Cylinders require lubricated bearing blocks with minimum bearing clearances. Bearing blocks should be carefully aligned and rigidly mounted so the trunnions will not be subjected to bending moments. The rod end should also be pivoted with the pivot pin in line and parallel to axis of the trunnion pins.
6. Clevis Mountings – Cylinders should be pivoted at both ends with centerline of pins parallel to each other. After cylinder is mounted, be sure to check to assure that the cylinder is free to swing through its working arc without interference from other machine parts.

Cylinder Trouble Shooting

External Leakage

1. Rod seal leakage can generally be traced to worn or damaged seals. Examine the piston rod for dents, gouges or score marks, and replace piston rod if surface is rough.
Rod seal leakage could also be traced to bushing wear. If clearance is excessive, replace rod bushing and seal. Rod seal leakage can also be traced to seal deterioration. If seals are soft or gummy or brittle, check compatibility of seal material with lubricant used if air cylinder, or operating fluid if hydraulic cylinder. Replace with seal material, which is compatible with these fluids. If the seals are hard or have lost elasticity, it is usually due to exposure to temperatures in excess of 165°F. (+74°C). Shield the cylinder from the heat source to limit temperature to 350°F. (+177°C.) and replace with fluorocarbon seals.
2. Cylinder tube seal leak can generally be traced to loose tie rods. Torque the tie rods to manufacturer's recommendation for that bore size.

Excessive pressure can also result in cylinder tube seal leak. Determine maximum pressure to rated limits. Replace seals and retorque tie rods as in paragraph above. Excessive pressure can also result in cylinder tube seal leak. Determine if the pressure rating of the cylinder has been exceeded. If so, bring the operating pressure down to the rating of the cylinder and have the tie rods replaced.

Pinched or extruded cylinder tube seal will also result in a leak. Replace cylinder tube seal and retorque as in paragraph above.

Cylinder tube seal leakage due to loss of radial squeeze which shows up in the form of flat spots or due to wear on the O.D. or I.D. – Either of these are symptoms of normal wear due to high cycle rate or length of service. Replace seals as per paragraph above.

Internal Leakage

1. Piston seal leak (by-pass) 1 to 3 cubic inches per minute leakage is considered normal for piston ring construction. Virtually no static leak with lipseal type seals on piston should be expected. Piston seal wear is a usual cause of piston seal leakage. Replace seals as required.
2. With lipseal type piston seals excessive back pressure due to over-adjustment of speed control valves could be a direct cause of rapid seal wear. Contamination in a hydraulic system can result in a scored cylinder bore, resulting in rapid seal wear. In either case, replace piston seals as required.
3. What appears to be piston seal leak, evidenced by the fact that the cylinder drifts, is not always traceable to the piston. To make sure, it is suggested that one side of the cylinder piston be pressurized and the fluid line at the opposite port be disconnected. Observe leakage. If none is evident, seek the cause of cylinder drift in other component parts in the circuit.

Cylinder Fails to Move the Load

1. Pneumatic or hydraulic pressure is too low. Check the pressure at the cylinder to make sure it is to circuit requirements.
2. Piston Seal Leak – Operate the valve to cycle the cylinder and observe fluid flow at valve exhaust ports at end of cylinder stroke. Replace piston seals if flow is excessive.
3. Cylinder is undersized for the load – Replace cylinder with one of a larger bore size.
4. Piston rod broken. Bring the operating conditions of the cylinder to the attention of our engineering department and have our factory repair the cylinder.

Erratic or Chatter Operation

1. Excessive friction at gland or piston bearing due to load misalignment – Correct cylinder-to-load alignment.
2. Cylinder sized too close to load requirements – Reduce load or install larger cylinder.
3. Erratic operation could be traced to the difference between static and kinetic friction. Install speed control valves to provide a back pressure to control the stroke.

Piston Rod Attachment & Rod Accessories

When connecting machinery components or rod clevises, rod eyes, etc. to Miller Style 2 (Threaded on Turndown Section) or Style 4 (Internally Threaded) Piston Rods, the attachments should be tightened to the torques given in chart 1. This torque or prestress triples the fatigue strength of the rod's threaded section and makes a stronger assembly than attaching the machinery component to a full diameter threaded rod

(Style 1) and torquing it against a lock nut. Miller recommends the Style 2 (Threaded on Turndown Section) Rod for most applications. Its square shoulder design helps assure proper alignment of cylinder to mechanism, eliminates need for a jam nut, provides fixed point for more accurate cylinder positioning, and simplifies piloting full rod diameter into mating part.

Cylinder Component Torque Values

Chart 1

Piston Rod Torque (ft./lbs.)		
Bores	Thread Size	Torque ft./lbs. *
1½	7/16-20	36
2, 2½	¾-16	125
3¼	1-14	250
4	1¼-12	460
5	1½-12	663
6	1 7/8-12	944
7	2¼-12	1315
8	2½-12	5050
-	3"-12	7070
10	3¼"-12	7940
-	3½"-12	12760
12	4"-12	12560
14	5½"-12	16275
16	6"-8	21600
18	7"-8	30850
20	8"-6	37700

Chart 2

Tie Rod Torque (ft./lbs.)				
Bore	Except Models 61, 62, 65, 66		Models 61, 62, 65, 66	
	Dry	Moly	Dry	Moly
1½	16		13	
2		32		27
2½		50		42
3¼		90		75
4		145		97
5		270		180
6		375		188
7		590		295
8		900		450
10		410		342
12		410		342
14		410		342
16		410		N/A
18		550		N/A
20		560		N/A

Chart 3

Bolted Bushing Mounting Screw Torque		
Piston Rod Diameter	Cap Screw Size	** Torque
5/8	10-32 x 3/8	76 in./lbs.
1 thru 3½	¼-28 x 5/8	180 in./lbs.
4 thru 10	5/16-24 x 1	360 in./lbs.

** Reduce torque by 25% if bushing is cadmium plated.

* Recommended Torques (ft. lbs) with MoS2 lubricant or equivalent.

Miller H Series Hydraulic Cylinder Selection Guide

Selecting a Miller Hydraulic Cylinder

Miller hydraulic cylinders are selected and sized primarily based on force requirements and available operating pressure. The H Series is a heavy-duty design intended for normal industrial service at internal operating pressures up to 3,000 PSI. It is available in 23 mounting styles and bore sizes from 1½" to 20".

H Series Pressure Rating

Nominal Pressure — 3,000 PSI

Notes:

1. If hydraulic operating pressure exceeds 3,000 PSI, send application data for engineering evaluation and recommendation.
2. Certain mounting styles and over-sized rod combinations have pressure rating limitations due to their inherent design. See mounting style catalog page for details.

Other Miller Hydraulic Cylinder Models

When evaluating your application, please review our other hydraulic cylinder models to be sure that you are selecting the model most appropriate to your requirements.

Certified Dimensions

Miller Fluid Power guarantees that all cylinders ordered from this catalog will have the dimensions as specified in this catalog — no waiting for special drawings to be prepared and sent. When required however, certified drawings are available at no extra cost.

Steps in Selecting the Correct Cylinder

Detailed engineering information on bore size selection, oversize and non-sag rods, stop tubes, determining port and pipe size, etc. is located in this catalog. See Table of Contents.

Step 1 — Determine the correct cylinder bore size required based upon operating pressure and thrust required.

Step 2 — Select the mounting style which is required for your application.

Step 3 — On the appropriate catalog page for the mounting style selected, review bore and rod sizes available and pressure rating limitations, if any.

Step 4 — Choose a rod end style and, if desired, rod end accessories, and optional cushions.

Step 5 — Consider the conditions listed below which may require further modifications to the cylinder you have selected. Application Engineering assistance is readily available by contacting any of the Miller locations listed on the back cover of this catalog.

Step 6 — Refer to "How to Order" section to develop the part number and place your order.

Application Condition	Check the following	Application Condition	Check the following
Rapid Starts or Stops	Use severe service pressure rating only. Confirm that sufficient thrust is available to accelerate or decelerate cylinder and load within prescribed distances. If optional cushions are selected and will be used to reduce shock during deceleration, check that peak pressures will be within acceptable limits.	Long Horizontal Stroke	Check to see if a non-sag piston rod is required to prevent excess sagging and resultant premature bushing and piston wear.
Long Stroke	Check whether stop tube may be required to prevent excess bearing loads and wear.	Operating Temperatures	The standard operating temperature range of the Urethane rod seal used in the H Series is -20° F to +160° F. For temperatures in excess of that range, optional spring-loaded PTFE seals will be required.
High Column Loading-Long Push Stroke	Determine if standard size piston rod is strong enough to accommodate intended load without buckling.	Sufficient Speed	Confirm that standard port size permits sufficient flow to accommodate speed requirements. Fluid flow velocity should not exceed 15 feet per sec.
Loads	When high side loads and similar severe or unusual operating conditions are anticipated, please consult a Miller application engineer for recommendations concerning optional bushing material and design.	Fluid Compatibility	The standard H Urethane rod seal is compatible with petroleum based fluids. PTFE seals are available for use with water glycol, water/oil emulsions and phosphate ester fluids up to 150°F. For cylinders using these fluids in excess of 150°F the Miller Series H cylinders with spring-loaded PTFE seals are recommended.

Fluid power cylinders are designed to be linear actuators. They are intended to provide motion and force along the centerline of the rod. Since they have limited capacity to withstand eccentric or radial loads, they should not be employed as linear bearings. Good machine design practice requires that proper alignment be maintained to avoid excessive bearing loads. Any premature failure resulting from side loading is not considered a warranty failure. If your design involves the possibility of side loading, please contact the Miller Fluid Power engineering department.

Miller H Series Hydraulic Cylinders

How To Order

How To Order

Example: H-72B2N - 0 04.00 - 008.00 - 01.75 - S 1 1 9

Series	Mounting Style▲	Bushing	Rod End Style	Cushions	Bore Dia.	Stroke	Rod Dia.	Port Type	Port Location		Modified
H DH (D= Dbl. Rod End)		B= Bolted Bushing R= Retainer Held Bushing	#0 #1 #2 (Std) #3 #4 #5 #6 #7 #8 #9† #X‡	R= Rod End Cushioned C= Cap End Cushioned B= Both Ends Cushioned N= Non-Cushioned				S= SAE N= NPT	Head End 1 (Std.) 2 3 4	Cap End 1 2 3 4	0= Standard 9= Modified (See * Below)

Note: The Standard (#1) port location is at the top of the cylinder in relation to the mountings as shown on the mounting dimensional pages in this catalog. These numbered locations are shown within the end views of the cylinders for each of the mountings indicated.

* The number 9 refers to any modifications from standard design. Non-Standard Modifications and options not identified in the part number identification above must be included on all orders.

▲ Mounting styles 72, 74, and 77 should have a minimum stroke equal to or longer than their bore size. Mounting Style 71 stroke should be twice the bore size.

† Customer must specify required AC, AD, AE, AF, and AM dimensions when ordering cylinders with Style #9 rod ends on 7-10 inch diameter piston rods.

‡ Special thread, extension, rod eye is available. To order specify "Style X" and give desired dimensions for KK, A, WB or W. If otherwise special, furnish dimensioned sketch.

Examples of Other Modifications and Options Include:

- Tie Rod Extensions
- Air Bleeds
- Rod End Modifications
- Special or Oversize Ports
- Keyways
- Key Retainers
- Stainless Steel Piston Rods
- Extra Heavy Chrome Plated Piston Rods
- Chrome Plated Tube I.D.
- Stop Tube
- External Drainback Rod Bushing
- Grease Fitted Rod Bushing
- Bronze Bushings
- Position Sensing Cylinder
- Special Materials
- Fluorocarbon Seals
- Non-Sag Piston Rods
- Adjustable Retract Stroke
- Adjustable Advance Stroke
- Metallic Rod Scrapers
- Drilling and Tapping Modifications
- Flush Tie Rod Nuts
- Heavy Duty Rod Bushing
- Epoxy or Special Paint
- Mixed Mounting Styles
- Piston Ring Construction
- Proximity Switches
- Modifications for Special Environments
- Close Stroke Tolerances
- Port in Rear Face of Cap

For other Non-Standard Modifications, contact Miller Fluid Power Engineering Dept.

Offer of Sale

The items described in this document and other documents or descriptions provided by Parker Hannifin Corporation, its subsidiaries and Divisions ("Company") and its authorized distributors, are hereby offered for sale at prices to be established by the Company, its subsidiaries and its authorized distributors. This offer and its acceptance by any customer ("Buyer") shall be governed by all of the following Terms and Conditions. Buyer's order for any such item, when communicated to the Company, its subsidiary or an authorized distributor ("Seller") verbally or in writing, shall constitute acceptance of this offer.

1. Terms and Conditions of Sale: All descriptions, quotations, proposals, offers, acknowledgments, acceptances and sales of Seller's products are subject to and shall be governed exclusively by the terms and conditions stated herein. Buyer's acceptance of any offer to sell is limited to these terms and conditions. Any terms or conditions in addition to, or inconsistent with those stated herein, proposed by Buyer in any acceptance of an offer by Seller, are hereby objected to. No such additional, different or inconsistent terms and conditions shall become part of the contract between Buyer and Seller unless expressly accepted in writing by Seller. Seller's acceptance of any offer to purchase by Buyer is expressly conditional upon Buyer's assent to all the terms and conditions stated herein, including any terms in addition to, or inconsistent with those contained in Buyer's offer. Acceptance of Seller's products shall in all events constitute such assent.

2. Payment: Payment shall be made by Buyer net 30 days from the date of delivery of the items purchased hereunder. Amounts not timely paid shall bear interest at the maximum rate permitted by law for each month or portion thereof that the Buyer is late in making payment. Any claims by Buyer for omissions or shortages in a shipment shall be waived unless Seller receives notice thereof within 30 days after Buyer's receipt of the shipment.

3. Delivery: Unless otherwise provided on the face hereof, delivery shall be made F.O.B. Seller's plant. Regardless of the method of delivery, however, risk of loss shall pass to Buyer upon Seller's delivery to a carrier. Any delivery dates shown are approximate only and Seller shall have no liability for any delays in delivery.

4. Warranty: Seller warrants that the items sold hereunder shall be free from defects in material or workmanship for a period of 18 months from date of shipment from the Company. **THIS WARRANTY COMPRISES THE SOLE AND ENTIRE WARRANTY PERTAINING TO ITEMS PROVIDED HEREUNDER. SELLER MAKES NO OTHER WARRANTY, GUARANTEE, OR REPRESENTATION OF ANY KIND WHATSOEVER. ALL OTHER WARRANTIES, INCLUDING BUT NOT LIMITED TO, MERCHANTABILITY AND FITNESS FOR PURPOSE, WHETHER EXPRESS, IMPLIED, OR ARISING BY OPERATION OF LAW, TRADE USAGE, OR COURSE OF DEALING ARE HEREBY DISCLAIMED.**

NOTWITHSTANDING THE FOREGOING, THERE ARE NO WARRANTIES WHATSOEVER ON ITEMS BUILT OR ACQUIRED WHOLLY OR PARTIALLY, TO BUYER'S DESIGN OR SPECIFICATIONS.

5. Limitation of Remedy: SELLER'S LIABILITY ARISING FROM OR IN ANY WAY CONNECTED WITH THE ITEMS SOLD OR THIS CONTRACT SHALL BE LIMITED EXCLUSIVELY TO REPAIR OR REPLACEMENT OF THE ITEMS SOLD OR REFUND OF THE PURCHASE PRICE PAID BY BUYER, AT SELLER'S SOLE OPTION. IN NO EVENT SHALL SELLER BE LIABLE FOR ANY INCIDENTAL, CONSEQUENTIAL OR SPECIAL DAMAGES OF ANY KIND OR NATURE WHATSOEVER, INCLUDING BUT NOT LIMITED TO LOST PROFITS ARISING FROM OR IN ANY WAY CONNECTED WITH THIS AGREEMENT OR ITEMS SOLD HEREUNDER, WHETHER ALLEGED TO ARISE FROM BREACH OF CONTRACT, EXPRESS OR IMPLIED WARRANTY, OR IN TORT, INCLUDING WITHOUT LIMITATION, NEGLIGENCE, FAILURE TO WARN OR STRICT LIABILITY.

6. Changes, Reschedules and Cancellations: Buyer may request to modify the designs or specifications for the items sold hereunder as well as the quantities and delivery dates thereof, or may request to cancel all or part of this order, however, no such requested modification or cancellation shall become part of the contract between Buyer and Seller unless accepted by Seller in a written amendment to this Agreement. Acceptance of any such requested modification or cancellation shall be at Seller's discretion, and shall be upon such terms and conditions as Seller may require.

7. Special Tooling: A tooling charge may be imposed for any special tooling, including without limitations, dies, fixtures, molds and patterns, acquired to manufacture items sold pursuant to this contract. Such special tooling shall be and remain Seller's property notwithstanding payment of any charges by Buyer. In no event will Buyer acquire any interest in apparatus belonging to Seller which is utilized in the manufacture of the items sold hereunder, even if such apparatus has been specially converted or adapted for such manufacture and notwithstanding any charges paid by Buyer. Unless otherwise agreed, Seller shall have the right to alter, discard or

otherwise dispose of any special tooling or other property in its sole discretion at any time.

8. Buyer's Property: Any designs, tools, patterns, materials, drawings, confidential information or equipment furnished by Buyer, or any other items which become Buyer's property, may be considered obsolete and may be destroyed by Seller after two (2) consecutive years have elapsed without Buyer placing an order for the items which are manufactured using such property. Seller shall not be responsible for any loss or damage to such property while it is in Seller's possession or control.

9. Taxes: Unless otherwise indicated on the face hereof, all prices and charges are exclusive of excise, sales, use, property, occupational or like taxes which may be imposed by any taxing authority upon the manufacture, sale or delivery of the items sold hereunder. If any such taxes must be paid by Seller or if Seller is liable for the collection of such tax, the amount thereof shall be in addition to the amounts for the items sold. Buyer agrees to pay all such taxes or to reimburse Seller therefore upon receipt of its invoice. If Buyer claims exemption from any sales, use or other tax imposed by any taxing authority, Buyer shall save Seller harmless from and against any such tax, together with any interest or penalties thereon which may be assessed if the items are held to be taxable.

10. Indemnity For Infringement of Intellectual Property Rights: Seller shall have no liability for infringement of any patents, trademarks, copyrights, trade dress, trade secrets or similar rights except as provided in this Part 10. Seller will defend and indemnify Buyer against allegations of infringement of U.S. patents, U.S. trademarks, copyrights, trade dress and trade secrets (hereinafter "Intellectual Property Rights"). Seller will defend at its expense and will pay the cost of any settlement or damages awarded in an action brought against Buyer based on an allegation that an item sold pursuant to this contract infringes the Intellectual Property Rights of a third party. Seller's obligation to defend and indemnify Buyer is contingent on Buyer notifying Seller within ten (10) days after Buyer becomes aware of such allegations of infringement, and Seller having sole control over the defense of any allegations or actions including all negotiations for settlement or compromise. If an item sold hereunder is subject to a claim that it infringes the Intellectual Property Rights of a third party, Seller may, at its sole expense and option, procure for Buyer the right to continue using said item, replace or modify said item so as to make it noninfringing, or offer to accept return of said item and return the purchase price less a reasonable allowance for depreciation. Notwithstanding the foregoing, Seller shall have no liability for claims of infringement based on information provided by Buyer, or directed to items delivered hereunder for which the designs are specified in whole or part by Buyer, or infringements resulting from the modification, combination or use in a system of any item sold hereunder. The foregoing provisions of this Part 10 shall constitute Seller's sole and exclusive liability and Buyer's sole and exclusive remedy for infringement of Intellectual Property Rights.

If a claim is based on information provided by Buyer or if the design for an item delivered hereunder is specified in whole or in part by Buyer, Buyer shall defend and indemnify Seller for all costs, expenses or judgements resulting from any claim that such item infringes any patent, trademark, copyright, trade dress, trade secret or any similar right.

11. Force Majeure: Seller does not assume the risk of and shall not be liable for delay or failure to perform any of Seller's obligations by reason of circumstances beyond the reasonable control of Seller (hereinafter "Events of Force Majeure"). Events of Force Majeure shall include without limitation, accidents, acts of God, strikes or labor disputes, acts, laws, rules or regulations of any government or government agency, fires, floods, delays or failures in delivery of carriers or suppliers, shortages of materials and any other cause beyond Seller's control.

12. Entire Agreement/Governing Law: The terms and conditions set forth herein, together with any amendments, modifications and any different terms or conditions expressly accepted by Seller in writing, shall constitute the entire Agreement concerning the items sold, and there are no oral or other representations or agreements which pertain thereto. This Agreement shall be governed in all respects by the law of the State of Ohio. No actions arising out of sale of the items sold hereunder or this Agreement may be brought by either party more than two (2) years after the cause of action accrues.

Safety Guide for Selecting and Using Hydraulic, Pneumatic Cylinders and Their Accessories

WARNING: ⚠ FAILURE OR IMPROPER SELECTION OR IMPROPER USE OF CYLINDERS AND THEIR RELATED ACCESSORIES CAN CAUSE DEATH, PERSONAL INJURY AND PROPERTY DAMAGE.

Before selecting or using Miller (The Company) cylinders or related accessories, it is important that you read, understand and follow the following safety information.

User Responsibility

Due to very wide variety of cylinder applications and cylinder operating conditions, The Company does not warrant that any particular cylinder is suitable for any specific application. This safety guide does not analyze all technical parameters that must be considered in selecting a product. The hydraulic and pneumatic cylinders outlined in this catalog are designed to The Company's design guide lines and do not necessarily meet the design guide lines of other agencies such as American Bureau of Shipping, ASME Pressure Vessel Code etc. The user, through its own analysis and testing, is solely responsible for:

- Making the final selection of the cylinders and related accessories.
- Determining if the cylinders are required to meet specific design requirements as required by the Agency(s) or industry standards covering the design of the user's equipment.
- Assuring that the user's requirements are met, OSHA requirements are met, and safety guidelines from the applicable agencies such as but not limited to ANSI are followed and that the use presents no health or safety hazards.
- Providing all appropriate health and safety warnings on the equipment on which the cylinders are used.

Seals

Part of the process of selecting a cylinder is the selection of seal compounds. Before making this selection, consult "How to Select a Miller Cylinder" opposite the "How to Order" page, or contact our engineering department.

The application of cylinders may allow fluids such as cutting fluids, wash down fluids etc. to come in contact with the external area of the cylinder. These fluids may attack the piston rod wiper and or the primary seal and must be taken into account when selecting and specifying seal compounds.

Dynamic seals will wear. The rate of wear will depend on many operating factors. Wear can be rapid if a cylinder is mis-aligned or if the cylinder has been improperly serviced. The user must take seal wear into consideration in the application of cylinders.

Piston Rods

Possible consequences of piston rod failure or separation of the piston rod from the piston include, but are not limited to are:

- Piston rod and or attached load thrown off at high speed.
- High velocity fluid discharge.
- Piston rod extending when pressure is applied in the piston retract mode.

Piston rods or machine members attached to the piston rod may move suddenly and without warning as a consequence of other conditions occurring to the machine such as, but not limited to:

- Unexpected detachment of the machine member from the piston rod.
- Failure of the pressurized fluid delivery system (hoses, fittings, valves, pumps, compressors) which maintain cylinder position.
- Catastrophic cylinder seal failure leading to sudden loss of pressurized fluid.
- Failure of the machine control system.

Following the recommendation of the "Piston Rod Selection Chart and Data" found in this catalog. The suggested piston rod diameter in these charts must be followed in order to avoid piston rod buckling.

Piston rods are not normally designed to absorb bending moments or loads which are perpendicular to the axis of piston rod motion. These additional loads can cause the piston rod to fail. If these types of additional loads are expected to be imposed on the piston rod, their magnitude should be made known to our engineering department.

The cylinder user should always make sure that the piston rod is securely attached to the machine member.

On occasion cylinders are ordered with double rods (a piston rod extended from both ends of the cylinder). In some cases a stop is threaded on to one of the piston rods and used as an external stroke adjuster. On occasions spacers are attached to the machine member connected to the piston rod and also used as a stroke adjuster. In both cases the stops will create a pinch point and the user should consider appropriate use of guards. If these external stops are not perpendicular to the mating contact surface, or if debris is trapped between the contact surfaces, a bending moment will be placed on the piston rod, which can lead to piston rod failure. An external stop will also negate the effect of cushioning and will subject the piston rod to impact loading. Those two (2) conditions can cause piston rod failure. Internal stroke adjusters are available with and without cushions. The use of external stroke adjusters should be reviewed with our engineering department.

The piston rod to piston and the stud to piston rod threaded connections are secured with an anaerobic adhesive. The strength of the adhesive decreases with increasing temperature. Cylinder which can be exposed to temperatures above +250°F (+121°C) are to be ordered with a non studded piston rod and a pinned piston to rod joint.

Cushions

Cushions should be considered for cylinder applications when the piston velocity is expected to be over 4 inches/second.

Cylinder cushions are normally designed to absorb the energy of a linear applied load. A rotating mass has considerably more energy than the same mass moving in a linear mode. Cushioning for a rotating mass application should be review by our engineering department.

Cylinder Mountings

Some cylinder mounting configurations may have certain limitations such as but not limited to minimum stroke for side or foot mounting cylinders or pressure de-ratings for certain flange mounts. Carefully review the catalog for these types of restrictions.

Always mount cylinders using the largest possible high tensile alloy steel socket head cap screws that can fit in the cylinder mounting holes and torque them to the manufacturer's recommendations for their size.

Port Fittings

Hydraulic cylinders applied with meter out or deceleration circuits are subject to intensified pressure at piston rod end.

The rod end pressure is approximately equal to:

$$\frac{\text{operating pressure} \times \text{effective cap end area}}{\text{effective rod end piston area}}$$

Contact your connector supplier for the pressure rating of individual connectors.

Cylinder Modifications or Repairs

Cylinders as shipped from the factory are not to be disassembled and or modified. If cylinders require modifications, these modifications must be done at company locations or by The Company's certified facilities. It is allowed to disassemble cylinders for the purpose of replacing seals or seal assemblies. However, this work must be done by strictly following all the instructions provided with the seal kits.

Notes:

Miller Fluid Power

500 South Wolf Road
Des Plaines, IL 60016 USA
(847) 298-2400
(800) 892-1008—FAX
Web site: www.millerfluidpower.com

Miller Fluid Power

8485 Parkhill Drive
Milton, Ontario
Canada L9T 5E9
(905) 693-3000
(905) 876-1958—FAX

All specifications and information subject
to change without notice or prior obligation.

Catalog M1112
10/03

