



**Cylinder Division**  
500 South Wolf Road  
Des Plaines, IL 60016  
(708) 298-2400

**Cylinder Division**  
1000 6th Street  
Owen Sound, Ontario N4K 5P1  
(519) 376-2691

**Service Bulletin 0995-M9**

**Gland Seal Kits**

Issued: March, 1995

Supersedes: None

# Gland Cartridges & Rod Seals

## For Series "2AN" Air Cylinder

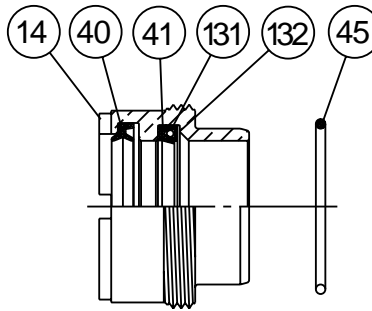

**GLAND CARTRIDGE KIT**

RG kit contains 1 each of the following:  
 symbol 14, gland, threaded cartridge type  
 symbol 40, rod Wiperseal  
 symbol 41, rod Lipseal  
 symbol 45, O-ring, gland to head seal  
 symbol 131, wick } 3" to 5 1/2" rods only  
 symbol 132, washer }

**ROD SEAL KIT**

RK kit contains 1 each of the following:  
 symbol 40, rod Wiperseal  
 symbol 41, rod Lipseal  
 symbol 45, O-ring, gland to head seal  
 symbol 131, wick } 3" to 5 1/2" rods only  
 symbol 132, washer }

Service kits of expendable parts for fluid power cylinders are stocked in principal industrial locations across the U.S.A. and other countries. For prompt delivery and complete information, contact your nearest distributor or Parker Hannifin office.

Service kits of expendable parts for fluid power cylinders are available for Class 1 fluid service.

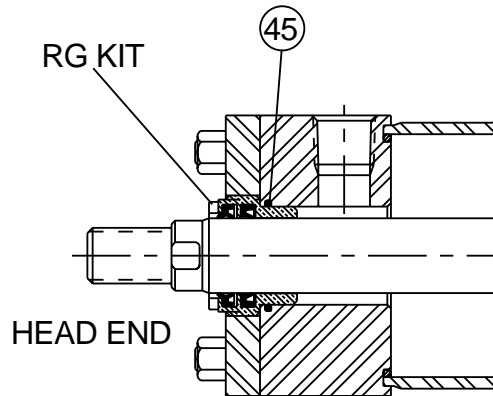

Standard Seals — Class 1 Service Kits are standard, and contain seals of Nitrile (Buna-N) elastomers. These seals are suitable for use when air is the operating medium.

The recommended operating temperature range for Class 1 seals is -10°F to +165°F. These seals will function at temperatures up to 200°F with reduced life.

Rod Dia.	RG Gland Cartridge Kit No.	RK Rod Seal Kit No.
	Includes RK Kit	Contains Rod Seals
5/8"	RG2AN00061	RK2AN00061
1"	RG2AN00101	RK2AN00101
1 3/8"	RG2AN00131	RK2AN00131
1 3/4"	RG2AN00171	RK2AN00171
2"	RG2AN00201	RK2AN00201
2 1/2"	RG2AN00251	RK2AN00251
3"	RG2AN00301	RK2AN00301
3 1/2"	RG2AN00351	RK2AN00351
4"	RG2AN00401	RK2AN00401
4 1/2"	RG2AN00451	RK2AN00451
5"	RG2AN00501	RK2AN00501
5 1/2"	RG2AN00551	RK2AN00551

**Retainer Bolt Torque\***

For Cylinders with Round or Small Square Gland Retainer

Screw Size	Torque	Torque
#10	15 in.-lbs.	17 cm-kg
1/4"	60 in.-lbs.	69 cm-kg
5/16"	10 ft.-lbs.	14 N-m
3/8"	20 ft.-lbs.	27 N-m
7/16"	35 ft.-lbs.	48 N-m

\*-0%, +5% tolerance

Cylinder Bore Size	Series 2AN					
	Cylinder Body Material					
	Steel		Brass		Fiberglass	
1 1/2"	60 in.-lbs.	69 cm-kg	36 in.-lbs.	42 cm-kg	-	-
2" & 2 1/2"	11 ft.-lbs.	15 N-m	72 in.-lbs.	83 cm-kg	-	-
3 1/4"	25 ft.-lbs.	34 N-m	18 ft.-lbs.	24 N-m	-	-
4"	25 ft.-lbs.	34 N-m	18 ft.-lbs.	24 N-m	-	-
5"	60 ft.-lbs.	81 N-m	44 ft.-lbs.	50 N-m	-	-
6"	60 ft.-lbs.	81 N-m	44 ft.-lbs.	50 N-m	-	-
8"	110 ft.-lbs.	149 N-m	80 ft.-lbs.	108 N-m	-	-
10"	148 ft.-lbs.	201 N-m	113 ft.-lbs.	153 N-m	78 ft.-lbs.	106 N-m
12"	172 ft.-lbs.	233 N-m	148 ft.-lbs.	201 N-m	78 ft.-lbs.	106 N-m
14"	275 ft.-lbs.	373 N-m	228 ft.-lbs.	309 N-m	118 ft.-lbs.	160 N-m

# How To Replace Cylinder Gland Packing

Fluid leakage around piston rod at the gland area will normally indicate a need to replace gland seals. First, remove cylinder from machine to which it is mounted or, if this is not feasible, disconnect the piston rod from rod clevis, knuckle or machine member to which it is fastened.

The Parker Hannifin gland is a unique cartridge design. It is threaded into the gland retainer plate, and all sizes are removable without disturbing the tie rod torque.

To remove the gland:

- Inspect the piston rod to make sure it is free of burrs or other displaced metal which would prevent sliding the gland off the rod.
- Unscrew the gland (right-hand thread) from the gland retainer plate. Or on 8" bore or larger air cylinders remove the bolted gland retainer by loosening the 4 socket headscrews. The gland protrudes from the face of the retainer and can be removed with vise grip pliers. Or use a Parker Hannifin gland wrench which is available for each gland size.

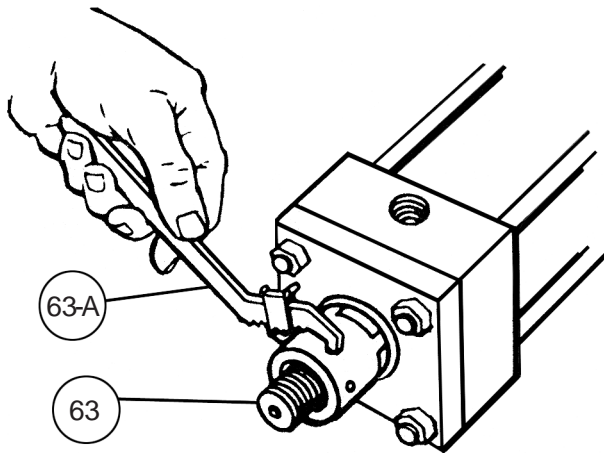

- Lubricate the rod with Lube-A-Cyl.
- Slide the gland off of the piston rod and remove the seals, wicks and washers, if present. Thoroughly clean the gland and seal grooves. Inspect gland bore for wear. If bore is worn, replace – using gland cartridge kit of proper size. (See opposite side.)
- If gland is not worn, replace seals only, using rod seal kit, with Lube-A-Cyl. Lubricate gland seal grooves and all new seals. Install wiperseal, Sym. 40, in groove closest to end of gland. Install lipseal, Sym. 41, in seal groove. Lips of seals should point toward the long bearing side of gland.

For 3" to 5 1/2" rod sizes:

If gland is not worn, replace seals only, using rod seal kit containing seals for proper size (see opposite side). Lubricate gland seal grooves and all new seals. Install wiperseal, Sym. 40, in groove closest to end of gland. Install lipseal, Sym. 41, in seal groove. **Lips of seal should point toward the long bearing side of gland.** Install wick, Sym. 131, and washer, Sym. 132. Immerse gland assembly in standard petroleum lubricating oil, "Union Oil" UN-ax-AW-315 or equivalent to soak wicks.

- An O-ring, Sym. 45, is supplied with each gland cartridge kit. It serves as a seal between the gland and the head. This O-ring is a static seal and does not normally require replacement. The original O-ring may be left in place, unless it is known to be leaking.

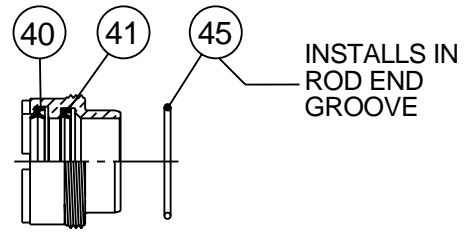

## Installation

Before installing a new gland, inspect the surface of the piston rod for scratches, burrs, dents or other damage. A damaged piston rod surface will result in premature rod seal failure.

Lubricate the bore of the gland and the seals with Parker "Lube-A-Cyl," and slide the gland over the end of the piston rod. Thread the gland into the retainer until it is seated firmly against the head. The gland-to-head O-ring, Sym. 45, serves as a torque prevailing lock.

THE SEALS ARE PRESSURE ACTUATED, SO NO FURTHER ADJUSTMENTS ARE NECESSARY.

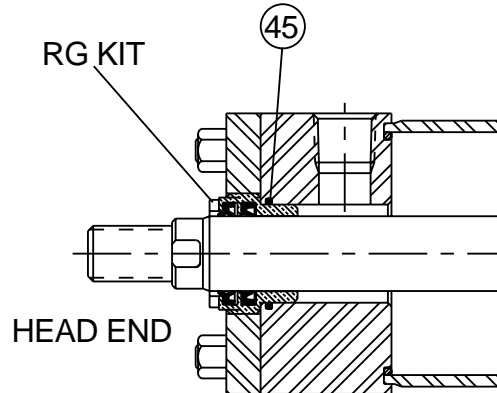

When replacing a gland on a rod which is threaded to the full diameter or so shaped that it could damage the seals, a slight rotary motion of the gland will help prevent damage. In addition, because full-diameter threads are usually supplied with the crest of the threads slightly truncated, a piece of shim stock or other thin, tough material can be wrapped around the threads to help protect the gland seals when they are being passed over the threads.

## Gland Cartridge Wrenches

Parker's exclusive gland cartridge design makes gland replacement only a minute's work...and the Gland Cartridge Wrench Set makes it even simpler. A specially designed face-type gland wrench with flared lugs slips into an exact, sure fit on the gland, while a self-locking spanner wrench grips the gland wrench securely. No fumbling for adjustment — no accidental scoring of the piston rod, the job is done quickly...easily...safely.

You can order the Cartridge Wrench or Spanner Wrench to fit the piston rod size used in your Parker Hannifin Cylinder.

See chart below.

Rod Diameter	Gland Wrench (Symbol 63)	Spanner Wrench (Symbol 63-A)
5/8"	069590 0000	011676 0000
1"	069591 0000	
1 3/8"	069592 0000	011703 0000
1 3/4"	069593 0000	
2"	069594 0000	011677 0000
2 1/2"	069595 0000	
3"	069596 0000	011677 0000
3 1/2"	069597 0000	
4"	069598 0000	
4 1/2"	083777 0000	011678 0000
5"	069599 0000	
5 1/2"	069600 0000	

### WARNING

FAILURE OR IMPROPER SELECTION OR IMPROPER USE OF THE PRODUCTS AND/OR SYSTEMS DESCRIBED HEREIN OR RELATED ITEMS CAN CAUSE DEATH, PERSONAL INJURY AND PROPERTY DAMAGE.

This document and other information from Parker Hannifin Corporation, its subsidiaries and authorized distributors provide product and/or system options for further investigation by users having expertise. It is important that you analyze all aspects of your application, including consequences of any failure and review the information concerning the product or system in the current product catalog. Due to the variety of operating conditions and applications for these products or systems, the user, through its own analysis and testing, is solely responsible for making the final selection of the products and systems and assuring that all performance, safety and warning requirements of the application are met.

The products described herein, including without limitation, product features, specifications, designs, availability and pricing, are subject to change by Parker Hannifin Corporation and its related companies at any time without notice.