

 **WARNING**

To avoid unpredictable system behavior that can cause personal injury and property damage:

- Disconnect electrical supply (when necessary) before installation, servicing, or conversion.
- Disconnect air supply and depressurize all air lines connected to this product before installation, servicing, or conversion.
- Operate within the manufacturer's specified pressure, temperature, and other conditions listed in these instructions.
- Medium must be moisture-free if ambient temperature is below freezing.
- Service according to procedures listed in these instructions.
- Installation, service, and conversion of these products must be performed by knowledgeable personnel who understand how pneumatic products are to be applied.
- After installation, servicing, or conversion, air and electrical supplies (when necessary) should be connected and the product tested for proper function and leakage. If audible leakage is present, or the product does not operate properly, do not put into use.
- Warnings and specifications on the product should not be covered by paint, etc. If masking is not possible, contact your local representative for replacement labels.

With Polyurethane Bowl

	kPa	PSIG	bar
Operating Pressure Maximum	1034	150	10
Operating Temperature Range	4°C to 49°C (40°F to 120°F)		

With Zinc Bowl

	kPa	PSIG	bar
Operating Pressure Maximum	2068	300	21
Operating Temperature Range	4°C to 82°C (40°F to 180°F)		

With Zinc Bowl & Wrap Around Sight Gauge

	kPa	PSIG	bar
Operating Pressure Maximum	1723	250	17.0
Operating Temperature Range	4°C to 66°C (40°F to 150°F)		

ANSI Symbols

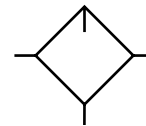

 **CAUTION**

Polyurethane bowls, sight glass and sight domes on these units may be attacked by certain chemicals. Never use solvents like carbon tetrachloride, trichlorethylene, acetone, or paint thinner to clean any parts. These elements can cause crazing or failure of the plastic parts. The polyurethane resin parts are compatible with most hydrocarbon based synthetic lubricants but, before using, check with the manufacturer of the lubricant or oil for compatibility with polyurethane resin.

TO CLEAN POLYURETHANE BOWLS USE MILD SOAP AND WATER ONLY!

 **WARNING**

FAILURE OR IMPROPER SELECTION OR IMPROPER USE OF THE PRODUCTS AND/OR SYSTEMS DESCRIBED HEREIN OR RELATED ITEMS CAN CAUSE DEATH, PERSONAL INJURY AND PROPERTY DAMAGE.

This document and other information from The Company, its subsidiaries and authorized distributors provide product and/or system options for further investigation by users having technical expertise. It is important that you analyze all aspects of your application, including consequences of any failure and review the information concerning the product or systems in the current product catalog. Due to the variety of operating conditions and applications for these products or systems, the user, through its own analysis and testing, is solely responsible for making the final selection of the products and systems and assuring that all performance, safety and warning requirements of the application are met.

The products described herein, including without limitation, product features, specifications, designs, availability and pricing, are subject to change by The Company and its subsidiaries at any time without notice.

EXTRA COPIES OF THESE INSTRUCTIONS ARE AVAILABLE FOR INCLUSION IN EQUIPMENT / MAINTENANCE MANUALS THAT UTILIZE THESE PRODUCTS. CONTACT YOUR LOCAL REPRESENTATIVE.

Introduction

Follow these instructions when installing, operating, or servicing the product.

Application Limits

These products are intended for use in general purpose compressed air systems only.

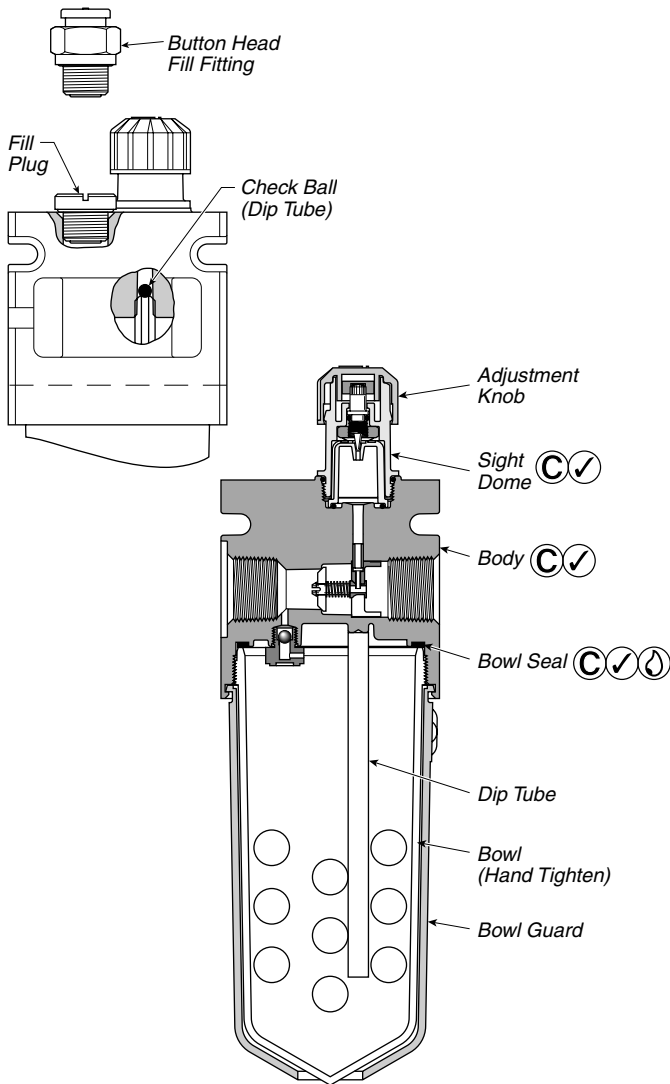

- ④ Lightly grease with provided lubricant.
- ✓ Inspect for nicks, scratches, and surface imperfections. If present, reduced service life is probable and future replacement should be planned.
- Ⓒ Clean with lint-free cloth.

Installation

1. The lubricator should be installed with reasonable accessibility for service whenever possible – repair service kits are available. Keep pipe or tubing lengths to a minimum with inside clean and free of dirt and chips. Pipe joint compound should be used sparingly and applied only to the male pipe – never into the female port. Do not use PTFE tape to seal pipe joints – pieces have a tendency to break off and lodge inside the unit, possibly causing malfunction. Also, new pipe or hose should be installed between the filter and equipment being protected.
2. The upstream pipe work must be clear of accumulated dirt and liquids.
3. Select a lubricator location as close as possible to the equipment being protected and upstream of any pressure regulator.
4. Install lubricator so that air flows in the direction of arrow on body.
5. Install lubricator vertically with bowl drain mechanism at the bottom (if so equipped).

Lubricant

For average conditions, the use of high quality SAE #10 (S.U.V. 150-200 SEC @ 100°F) oil is recommended. Other lubricants, as specified by the maker of the equipment to be lubricated, may be used if not heavier than SAE #40 (S.U.V. 800 SEC @ 100°F).

Filling

Lubricators may be filled under pressure, and without shutting down equipment. To fill through the fill port, a long spout oil can must be used. Slowly remove fill plug and tip of spout to bottom of fill port recess or oil blow back will occur. Fill to within 1/4" of top of bowl using correct oil. Lubricators may also be filled by depressurizing the system, or slowly removing the fill plug and then removing the bowl. After bowl has been filled, replace and ensure it has been returned to a locking position before repressurizing the system.

Adjustment

The adjustment knob is factory set so that, when turned fully clockwise, no oil is delivered to the venturi for atomization, and equipment is not being lubricated. To adjust oil drip rate, turn on the air, start flow and set knob to obtain the desired drip rate, which is visible through the sight dome. As a start, one to two drops per minute is suggested, correct lubrication being a matter of experience and demand. Clockwise rotation of knob decreases oil feed rate. To check lubrication, hold thumbnail or a mirror near the equipment exhaust. A heavy film indicates over-lubrication and the drip rate should be reduced by turning knob to a lower setting.

Maintenance - Cleaning

If both air and oil are kept clean, and the oil level never allowed below end of tube in the bowl, the lubricator should provide long periods of unattended service. Cessation of oil dripping through the sight dome, irrespective of knob adjustment, is an indication that cleaning is necessary. To clean, it is not necessary to remove lubricator from the line. Depressurize and disassemble using the drawing on reverse as a guide. In most instances, cleaning is needed only in the oil metering area. Pull off adjusting knob, unscrew sight dome assembly, remove inner drip spout and clean with household soap. **PLASTIC BOWLS AND SIGHT DOME MUST BE CLEANED WITH HOUSEHOLD SOAP ONLY.**

Kits Available

Description	Product Number	Bowl Type
Bowl*		
Polyurethane	BKL105B	B
Zinc	BKL105D	D
Zinc with Wrap Around Sight Gauge	BKL105W	W
Bowl Seal (In Bowl Kits)	GSK-F105-1015	—
Repair Kit		
Tamper-resistant Sight Dome Repair Kit	RKL100	B, D, W
Adjusting Knob	L100-0726P	—
Button Head Fill Fitting	SAA606C109-1	—
Fill Plug	SA606B4	—
Check Ball (Dip Tube)	606X106	—

*Bowl kits include bowl seal and bowl guard assembly.