

Pneumatic Division

Richland, Michigan USA

www.parker.com/pneumatics



VIKING XTREME VALVE SERIES

Bulletin Number		Bulletin Description	
<input type="checkbox"/>	V695P	Rev. D	Valves, Installation & Service Instructions
<input type="checkbox"/>	V696P	Rev. 2	Extruded Manifold, Assembly Procedures
<input type="checkbox"/>	Safety Guide		PDN Safety Guide



Visit www.pdnplu.com for additional instruction sheets.



Pneumatic Division
Richland, Michigan 49083

Installation & Service Instructions
V695P

Viking Xtreme Air Control Valves
1/8", 1/4", 3/8", 1/2" Inline

ISSUED: March, 2016

Supersedes: March, 2015

Doc. #V695P, EN #160073, Rev. D

⚠ WARNING

To avoid unpredictable system behavior that can cause personal injury and property damage:

- Disconnect electrical supply (when necessary) before installation, servicing, or conversion.
- Disconnect air supply and depressurize all air lines connected to this product before installation, servicing, or conversion.
- Operate within the manufacturer's specified pressure, temperature, and other conditions listed in these instructions.
- Medium must be moisture-free if ambient temperature is below freezing.
- Service according to procedures listed in these instructions.
- Installation, service, and conversion of these products must be performed by knowledgeable personnel who understand how pneumatic products are to be applied.
- After installation, servicing, or conversion, air and electrical supplies (when necessary) should be connected and the product tested for proper function and leakage. If audible leakage is present, or the product does not operate properly, do not put into use.
- Warnings and specifications on the product should not be covered by paint, etc. If masking is not possible, contact your local representative for replacement labels.

⚠ WARNING

FAILURE OR IMPROPER SELECTION OR IMPROPER USE OF THE PRODUCTS AND/OR SYSTEMS DESCRIBED HEREIN OR RELATED ITEMS CAN CAUSE DEATH, PERSONAL INJURY AND PROPERTY DAMAGE.

This document and other information from Parker Hannifin Corporation, its subsidiaries and authorized distributors provide product and/or system options for further investigation by users having technical expertise. It is important that you analyze all aspects of your application, including consequences of any failure and review the information concerning the product or systems in the current product catalog. Due to the variety of operating conditions and applications for these products or systems, the user, through its own analysis and testing, is solely responsible for making the final selection of the products and systems and assuring that all performance, safety and warning requirements of the application are met.

The products described herein, including without limitation, product features, specifications, designs, availability and pricing, are subject to change by Parker Hannifin Corporation and its subsidiaries at any time without notice.

EXTRA COPIES OF THESE INSTRUCTIONS ARE AVAILABLE FOR INCLUSION IN EQUIPMENT / MAINTENANCE MANUALS THAT UTILIZE THESE PRODUCTS. CONTACT YOUR LOCAL REPRESENTATIVE.

⚠ WARNING

Air exhausting from one valve into the exhaust gallery of the manifold assembly may momentarily pressurize other valve circuits open to the same gallery. Design the circuit such that there is no hazard or consequence of damage from this action.

Safety Guide

For more complete information on recommended application guidelines, see the Safety Guide section of Pneumatic Division catalogs or you can download the **Pneumatic Division Safety Guide** at: www.parker.com/safety

Introduction

Follow these instructions when installing, operating, or servicing the product.

Application Limits

These products are intended for use in general purpose compressed air systems only.

Operating Pressure

Maximum: Normal Version.....145 PSIG (10 bar)

Extreme Version (P2LAX & P2LBX).....232 PSIG (16 bar)
(P2LCX & P2LDX).....174 PSIG (12 bar)

Minimum:

Valve Type - Internal Pilot	Minimum PSIG (bar)			
	P2LAX	P2LBX	P2LCX	P2LDX
Single Sol - Spring Return	46 (3.2)	51 (3.5)	51 (3.5)	51 (3.5)
Single Remote Pilot - Spring Return	46 (3.2)	51 (3.5)	51 (3.5)	51 (3.5)
Double Solenoid - 2-Position	22 (1.5)	22 (1.5)	22 (1.5)	22 (1.5)
Double Remote Pilot - 2-Position	22 (1.5)	22 (1.5)	22 (1.5)	22 (1.5)
Double Solenoid - 3-Position (APB, PC, CE)	51 (3.5)	51 (3.5)	51 (3.5)	51 (3.5)
Double Remote Pilot - 3-Position (APB, PC, CE)	51 (3.5)	51 (3.5)	51 (3.5)	51 (3.5)

Valve Type - External Pilot	P2LAX	P2LBX	P2LCX	P2LDX
All Viking Series	Vacuum			

NOTE: Solenoid operated valves specified for external pilot or double air pilot operated valves may have pressures down to vacuum in the main valve. External pilot pressure and air pilot signals must be greater than or equal to that in the main valve, but not exceed the ranges above.

Temperature Range:

Normal: 14°F to 122°F (-10°C to 50°C)

Extreme: -40°F to 140°F (-40°C to 60°C)

Lubrication

Filtered and lubricated air is necessary for maximum valve life and minimum maintenance. If in-service lubrication is used, lubricate with a straight paraffin based mineral oil having an ISO viscosity grade of 32 (e.g. Sunvis 932).

NOTE: Once in-service lubrication is initiated, the practice should be continued in order to maximize valve life.

General Installation & Operating Instructions

Valve should be installed with reasonable accessibility for service whenever possible. Repair service kits are available. Keep pipe or tubing clean and free of dirt and chips. Pipe joint compound should be used sparingly and applied only to the male pipe - never into the female port. Do not use PTFE tape to seal pipe joints - pieces have a tendency to break off and lodge inside the unit, possibly causing malfunction. After valve assembly is complete, plumb the valve, turn on air pressure and electrical power source. Test valve for functional operation and internal and external leakage. If leakage is audible (indicating improper assembly is likely), do not operate. Conduct assembly again.

Installation

⚠ CAUTION: It is recommended that double operated 2-Position valves be mounted so that the axis of the main valve spool is in the horizontal plane. The valve may be rotated 360° around the axis for mounting convenience.

Maintenance & Trouble Shooting Hints

Valve Not Shifting Completely When Energized:

1. Check to insure that the proper voltage is supplied to the solenoids.
2. Check to insure that the minimum supply pressure is equal to that shown in the Application Limits chart above.
3. Check for possible restrictions in air supply, such as undersized hoses, fittings, or quick disconnects.
4. Check to insure that the spool moves smoothly.
5. Check spool for proper installation, dirt, or damage.

Air Leakage Through Exhaust Ports:

1. Check for internal leakage in the cylinder being operated by the valve.
2. Check condition of the spool for proper alignment, damaged seals and dirt contamination.
3. Check for missing, damaged, or incorrectly assembled seals and gaskets.

If installing new spool: Remove old spool assembly, taking care not to scratch bore. Install new spool assembly into clean bore, taking care to install squarely and push slowly to avoid damaging the spool or the valve bore.

If installing new piston: Refer to drawing for proper orientation. Install piston/seal assembly into the operator bore, taking care to assure the lips of the seal pass smoothly into the bore.

- Ⓐ Lightly grease with provided lubricant.
- Ⓑ Inspect for nicks, scratches, and surface imperfections. If present, reduced service life is probable and future replacement should be planned.
- Ⓒ Clean with lint-free cloth.

* If more aggressive cleaning is required, use mineral spirits or equivalent solvent and dry thoroughly.

Torque Chart		
P2LA	M4	15 to 18 in.lb. (1.7 to 2.0 Nm)
P2LB	M3	10 to 12 in.lb. (1.1 to 1.4 Nm)
P2LC	M4	15 to 18 in.lb. (1.7 to 2.0 Nm)
P2LD	M4	15 to 18 in.lb. (1.7 to 2.0 Nm)

A - 30mm Square
3-Pin ISO Form A

B - 22mm Rectangular
3-Pin DIN 43650B

H - 1/2" Conduit
18" Leads

R - 1/2" Conduit
72" Leads

G - Grommet
18" Leads

Q - Grommet
72" Leads

7 - M12, 4-Pin

15 - 15mm, 3-Pin
DIN 43650C

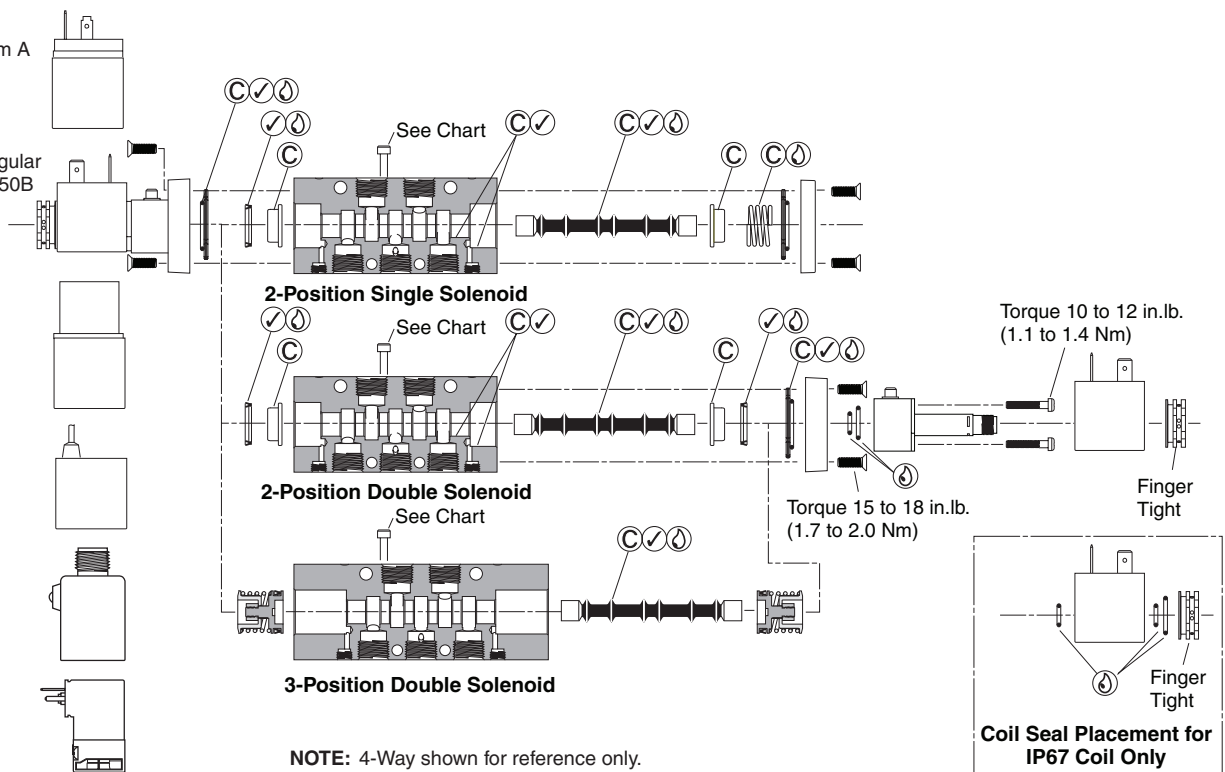

Service Kits Available:

Service kits are available for the pilot operators and solenoids only. See the product catalog or consult local representative for kits not listed.

Wiring

Follow all requirements for local and national electrical codes.

Electrical Connection:

1. Valve with lead wires should have power connected to the black wires. Ground should be connected to the green wire if provided.
2. Valves with 3-Pin male terminals should have power connected to the parallel terminals. Ground should be connected to the perpendicular terminal.

Endcap Orientation

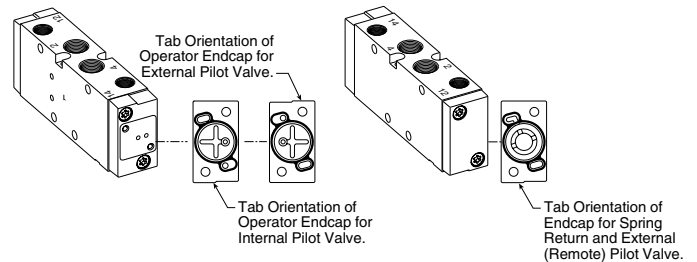

NOTE: 4-Way shown for reference only.

15mm Solenoid Mount, Kit PFA22-15

Adaptor kit for 15mm solenoid connecting to valve, kit PFA22-15 includes adaptor (1), O-rings (2), gasket (1), screws (4)

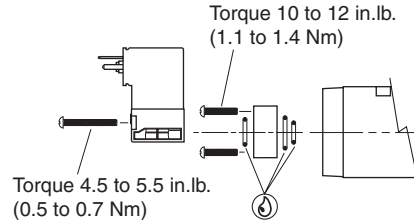

Torque 10 to 12 in.lb.
(1.1 to 1.4 Nm)

Torque 15 to 18 in.lb.
(1.7 to 2.0 Nm)

Finger Tight
Finger Tight
Coil Seal Placement for IP67 Coil Only

NOTE: 4-Way shown for reference only.



Pneumatic Division
Richland, Michigan 49083

Assembly Procedure:
V696P
Viking Extreme Air Control Valves
Extruded Manifold
ISSUED: June, 2012
Supersedes: December, 2006
Doc. #V696P, EN #120102, Rev. 2

V696P

⚠ WARNING

To avoid unpredictable system behavior that can cause personal injury and property damage:

- Disconnect electrical supply (when necessary) before installation, servicing, or conversion.
- Disconnect air supply and depressurize all air lines connected to this product before installation, servicing, or conversion.
- Operate within the manufacturer's specified pressure, temperature, and other conditions listed in these instructions.
- Medium must be moisture-free if ambient temperature is below freezing.
- Service according to procedures listed in these instructions.
- Installation, service, and conversion of these products must be performed by knowledgeable personnel who understand how pneumatic products are to be applied.
- After installation, servicing, or conversion, air and electrical supplies (when necessary) should be connected and the product tested for proper function and leakage. If audible leakage is present, or the product does not operate properly, do not put into use.
- Warnings and specifications on the product should not be covered by paint, etc. If masking is not possible, contact your local representative for replacement labels.

⚠ WARNING

FAILURE OR IMPROPER SELECTION OR IMPROPER USE OF THE PRODUCTS AND/OR SYSTEMS DESCRIBED HEREIN OR RELATED ITEMS CAN CAUSE DEATH, PERSONAL INJURY AND PROPERTY DAMAGE.

This document and other information from Parker Hannifin Corporation, its subsidiaries and authorized distributors provide product and/or system options for further investigation by users having technical expertise. It is important that you analyze all aspects of your application, including consequences of any failure and review the information concerning the product or systems in the current product catalog. Due to the variety of operating conditions and applications for these products or systems, the user, through its own analysis and testing, is solely responsible for making the final selection of the products and systems and assuring that all performance, safety and warning requirements of the application are met.

The products described herein, including without limitation, product features, specifications, designs, availability and pricing, are subject to change by Parker Hannifin Corporation and its subsidiaries at any time without notice.

EXTRA COPIES OF THESE INSTRUCTIONS ARE AVAILABLE FOR INCLUSION IN EQUIPMENT / MAINTENANCE MANUALS THAT UTILIZE THESE PRODUCTS. CONTACT YOUR LOCAL REPRESENTATIVE.

⚠ WARNING

Air exhausting from one valve into the exhaust gallery of the manifold assembly may momentarily pressurize other valve circuits open to the same gallery. Design the circuit such that there is no hazard or consequence of damage from this action.

Safety Guide

For more complete information on recommended application guidelines, see the Safety Guide section of Pneumatic Division catalogs or you can download the **Pneumatic Division Safety Guide** at: www.parker.com/safety

Application limits, wiring instructions, and instructions for the proper installation of the valves for this manifold are shown in instruction form V-695P, which was shipped with the valve. Service kits and other service instruction sheets are also referenced on this form. Copies of instruction form V-695P are available from your local representative.

Assembly Procedure:

Notes:

1. For 4-Way valves, it is recommended valves be installed so outlet ports #4 are all in line. Install the valves so that the exhaust ports 3 and 5 coincide with the corresponding ports on the manifold.

Assembly:

1. Place bar manifold horizontal with o-ring grooves facing up. Install three (3) o-rings (Item #89) into three counterbores for 4-Way or two (2) o-rings (Item #89) into two counterbores for 3-Way valves.
2. Place each valve at its corresponding location and fasten with socket head cap screws (Item #84). Tighten screws per torque chart.
3. Make plumbing and electrical connections.
4. Turn on air pressure and electrical power source. Test for proper functional operation and for internal and external air leakage. If leakage is audible (indicating improper assembly is likely), do not operate - conduct assembly again.

4-Way

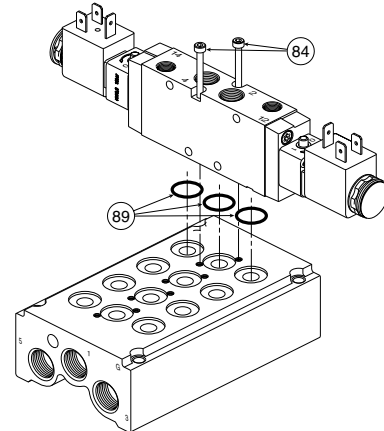

3-Way

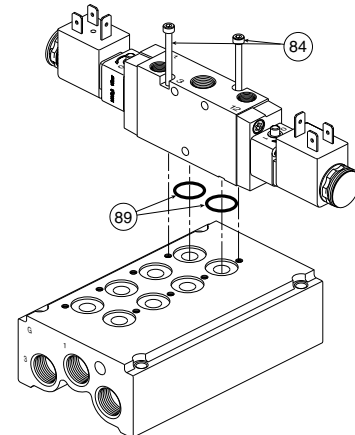

Torque Chart

P2LA	M4	15 to 18 in. lb. (1.7 to 2.0 Nm)
P2LB	M3	10 to 12 in. lb. (1.1 to 1.4 Nm)
P2LC	M4	15 to 18 in. lb. (1.7 to 2.0 Nm)

Viking Extreme Series Air Control Valves Extruded Manifold Blanking Plate Kits

V696P

Type	Kit Number
P2LAX	P2LAXK20P (4-Way)
P2LBX	P2LBXK20P (4-Way)
P2LCX	P2LCXK20P (3 & 4-Way)
P2LAX	P2LAXK30P (3-Way)
P2LBX	P2LBXK30P (3-Way)

Kit includes:

(1) Plate, (2) Screws, (3) O-rings

1. Install three (3) o-rings for 4-Way valves or two (2) o-rings for 3-Way valves, provided in kit, (Item #89) into counterbores on top of manifold base.
2. Attach plate (Item #92) to manifold using two (2) screws (Item #93). Tighten screws per torque chart.
3. For P2LC blanking plate, install three (3) pipe plugs (Item #94) into ports.

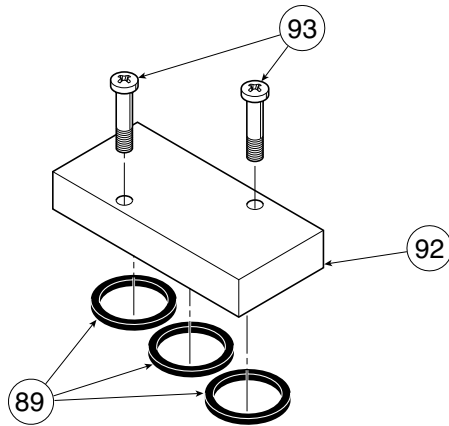

Viking P2LA & P2LB Blanking Plate (4-Way)

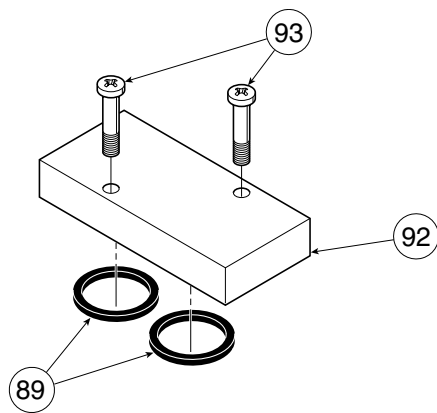

Viking P2LA & P2LB Blanking Plate (3-Way)

4. For PL2C with single pressure intermediate supply, install two (2) pipe plugs (Item #94) into two outside ports. Supply connection to common galley #1 is made to center port.
5. For PL2C with additional exhaust ports, install one (1) pipe plug (Item #94) into the center port for single pressure systems or two (2) pipe plugs (Item #94) into the two outside ports for dual pressure systems.
6. Turn on air pressure and check for leakage. If leakage is audible (indicating improper assembly is likely), do not operate - conduct assembly again.

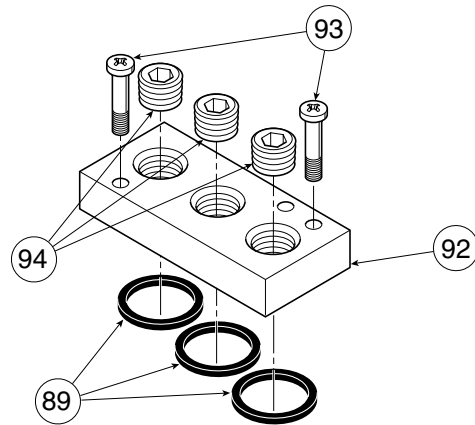

Viking P2LC Blanking Plate (3 & 4 Way)

Torque Chart		
P2LA	M4	15 to 18 in. lb. (1.7 to 2.0 Nm)
P2LB	M3	10 to 12 in. lb. (1.1 to 1.4 Nm)
P2LC	M4	15 to 18 in. lb. (1.7 to 2.0 Nm)



Pneumatic Division
Richland, Michigan 49083
269-629-5000

PDNSG-1

Pneumatic Division Safety Guide

ISSUED: August 1, 2006

Supersedes: June 1, 2006

Safety Guide For Selecting And Using Pneumatic Division Products And Related Accessories

WARNING:

FAILURE OR IMPROPER SELECTION OR IMPROPER USE OF PNEUMATIC DIVISION PRODUCTS, ASSEMBLIES OR RELATED ITEMS ("PRODUCTS") CAN CAUSE DEATH, PERSONAL INJURY, AND PROPERTY DAMAGE. POSSIBLE CONSEQUENCES OF FAILURE OR IMPROPER SELECTION OR IMPROPER USE OF THESE PRODUCTS INCLUDE BUT ARE NOT LIMITED TO:

- Unintended or mistimed cycling or motion of machine members or failure to cycle
- Work pieces or component parts being thrown off at high speeds.
- Failure of a device to function properly for example, failure to clamp or unclamp an associated item or device.
- Explosion
- Suddenly moving or falling objects.
- Release of toxic or otherwise injurious liquids or gasses.

Before selecting or using any of these Products, it is important that you read and follow the instructions below.

1. GENERAL INSTRUCTIONS

- 1.1. Scope:** This safety guide is designed to cover general guidelines on the installation, use, and maintenance of Pneumatic Division Valves, FRLs (Filters, Pressure Regulators, and Lubricators), Vacuum products and related accessory components.
- 1.2. Fail-Safe:** Valves, FRLs, Vacuum products and their related components can and do fail without warning for many reasons. Design all systems and equipment in a fail-safe mode, so that failure of associated valves, FRLs or Vacuum products will not endanger persons or property.
- 1.3. Relevant International Standards:** For a good guide to the application of a broad spectrum of pneumatic fluid power devices see: ISO 4414:1998, Pneumatic Fluid Power – General Rules Relating to Systems. See www.iso.org for ordering information.
- 1.4. Distribution:** Provide a copy of this safety guide to each person that is responsible for selection, installation, or use of Valves, FRLs or Vacuum products. Do not select, or use Parker valves, FRLs or vacuum products without thoroughly reading and understanding this safety guide as well as the specific Parker publications for the products considered or selected.
- 1.5. User Responsibility:** Due to the wide variety of operating conditions and applications for valves, FRLs, and vacuum products Parker and its distributors do not represent or warrant that any particular valve, FRL or vacuum product is suitable for any specific end use system. This safety guide does not analyze all technical parameters that must be considered in selecting a product. The user, through its own analysis and testing, is solely responsible for:
 - Making the final selection of the appropriate valve, FRL, Vacuum component, or accessory.
 - Assuring that all user's performance, endurance, maintenance, safety, and warning requirements are met and that the application presents no health or safety hazards.
 - Complying with all existing warning labels and / or providing all appropriate health and safety warnings on the equipment on which the valves, FRLs or Vacuum products are used; and,
 - Assuring compliance with all applicable government and industry standards.
- 1.6. Safety Devices:** Safety devices should not be removed, or defeated.
- 1.7. Warning Labels:** Warning labels should not be removed, painted over or otherwise obscured.
- 1.8. Additional Questions:** Call the appropriate Parker technical service department if you have any questions or require any additional information. See the Parker publication for the product being considered or used, or call 1-800-CPARKER, or go to www.parker.com, for telephone numbers of the appropriate technical service department.

2. PRODUCT SELECTION INSTRUCTIONS

- 2.1. Flow Rate:** The flow rate requirements of a system are frequently the primary consideration when designing any pneumatic system. System components need to be able to provide adequate flow and pressure for the desired application.
- 2.2. Pressure Rating:** Never exceed the rated pressure of a product. Consult product labeling, Pneumatic Division catalogs or the instruction sheets supplied for maximum pressure ratings.
- 2.3. Temperature Rating:** Never exceed the temperature rating of a product. Excessive heat can shorten the life expectancy of a product and result in complete product failure.
- 2.4. Environment:** Many environmental conditions can affect the integrity and suitability of a product for a given application. Pneumatic Division products are designed for use in general purpose industrial applications. If these products are to be used in unusual circumstances such as direct sunlight and/or corrosive or caustic environments, such use can shorten the useful life and lead to premature failure of a product.
- 2.5. Lubrication and Compressor Carryover:** Some modern synthetic oils can and will attack nitrile seals. If there is any possibility of synthetic oils or greases migrating into the pneumatic components check for compatibility with the seal materials used. Consult the factory or product literature for materials of construction.
- 2.6. Polycarbonate Bowls and Sight Glasses:** To avoid potential polycarbonate bowl failures:
 - Do not locate polycarbonate bowls or sight glasses in areas where they could be subject to direct sunlight, impact blow, or temperatures outside of the rated range.
 - Do not expose or clean polycarbonate bowls with detergents, chlorinated hydro-carbons, ketones, esters or certain alcohols.
 - Do not use polycarbonate bowls or sight glasses in air systems where compressors are lubricated with fire resistant fluids such as phosphate ester and di-ester lubricants.

Pneumatic Division Safety Guide

2.7. Chemical Compatibility: For more information on plastic component chemical compatibility see Pneumatic Division technical bulletins Tec-3, Tec-4, and Tec-5

2.8. Product Rupture: Product rupture can cause death, serious personal injury, and property damage.

- Do not connect pressure regulators or other Pneumatic Division products to bottled gas cylinders.
- Do not exceed the maximum primary pressure rating of any pressure regulator or any system component.
- Consult product labeling or product literature for pressure rating limitations.

3. PRODUCT ASSEMBLY AND INSTALLATION INSTRUCTIONS

3.1. Component Inspection: Prior to assembly or installation a careful examination of the valves, FRLs or vacuum products must be performed. All components must be checked for correct style, size, and catalog number. DO NOT use any component that displays any signs of nonconformance.

3.2. Installation Instructions: Parker published Installation Instructions must be followed for installation of Parker valves, FRLs and vacuum components. These instructions are provided with every Parker valve or FRL sold, or by calling 1-800-CPARKER, or at www.parker.com.

3.3. Air Supply: The air supply or control medium supplied to Valves, FRLs and Vacuum components must be moisture-free if ambient temperature can drop below freezing

4. VALVE AND FRL MAINTENANCE AND REPLACEMENT INSTRUCTIONS

4.1. Maintenance: Even with proper selection and installation, valve, FRL and vacuum products service life may be significantly reduced without a continuing maintenance program. The severity of the application, risk potential from a component failure, and experience with any known failures in the application or in similar applications should determine the frequency of inspections and the servicing or replacement of Pneumatic Division products so that products are replaced before any failure occurs. A maintenance program must be established and followed by the user and, at minimum, must include instructions 4.2 through 4.10.

4.2. Installation and Service Instructions: Before attempting to service or replace any worn or damaged parts consult the appropriate Service Bulletin for the valve or FRL in question for the appropriate practices to service the unit in question. These Service and Installation Instructions are provided with every Parker valve and FRL sold, or are available by calling 1-800-CPARKER, or by accessing the Parker web site at www.parker.com.

4.3. Lockout / Tagout Procedures: Be sure to follow all required lockout and tagout procedures when servicing equipment. For more information see: OSHA Standard – 29 CFR, Part 1910.147, Appendix A, The Control of Hazardous Energy – (Lockout / Tagout)

4.4. Visual Inspection: Any of the following conditions requires immediate system shut down and replacement of worn or damaged components:

- Air leakage: Look and listen to see if there are any signs of visual damage to any of the components in the system. Leakage is an indication of worn or damaged components.
- Damaged or degraded components: Look to see if there are any visible signs of wear or component degradation.
- Kinked, crushed, or damaged hoses. Kinked hoses can result in restricted air flow and lead to unpredictable system behavior.
- Any observed improper system or component function: Immediately shut down the system and correct malfunction.
- Excessive dirt build-up: Dirt and clutter can mask potentially hazardous situations.

Caution: Leak detection solutions should be rinsed off after use.

4.5. Routine Maintenance Issues:

- Remove excessive dirt, grime and clutter from work areas.
- Make sure all required guards and shields are in place.

4.6. Functional Test: Before initiating automatic operation, operate the system manually to make sure all required functions operate properly and safely.

4.7. Service or Replacement Intervals: It is the user's responsibility to establish appropriate service intervals. Valves, FRLs and vacuum products contain components that age, harden, wear, and otherwise deteriorate over time. Environmental conditions can significantly accelerate this process. Valves, FRLs and vacuum components need to be serviced or replaced on routine intervals. Service intervals need to be established based on:

- Previous performance experiences.
- Government and / or industrial standards.
- When failures could result in unacceptable down time, equipment damage or personal injury risk.

4.8. Servicing or Replacing of any Worn or Damaged Parts: To avoid unpredictable system behavior that can cause death, personal injury and property damage:

- Follow all government, state and local safety and servicing practices prior to service including but not limited to all OSHA Lockout Tagout procedures (OSHA Standard – 29 CFR, Part 1910.147, Appendix A, The Control of Hazardous Energy – Lockout / Tagout).
- Disconnect electrical supply (when necessary) before installation, servicing, or conversion.
- Disconnect air supply and depressurize all air lines connected to system and Pneumatic Division products before installation, service, or conversion.
- Installation, servicing, and / or conversion of these products must be performed by knowledgeable personnel who understand how pneumatic products are to be applied.
- After installation, servicing, or conversions air and electrical supplies (when necessary) should be connected and the product tested for proper function and leakage. If audible leakage is present, or if the product does not operate properly, do not put product or system into use.
- Warnings and specifications on the product should not be covered or painted over. If masking is not possible, contact your local representative for replacement labels.

4.9. Putting Serviced System Back into Operation: Follow the guidelines above and all relevant Installation and Maintenance Instructions supplied with the valve FRL or vacuum component to insure proper function of the system.