

PXM Pilot Exhaust Module (for the H Series ISO Valve Manifold)

Bulletin 0600-B102

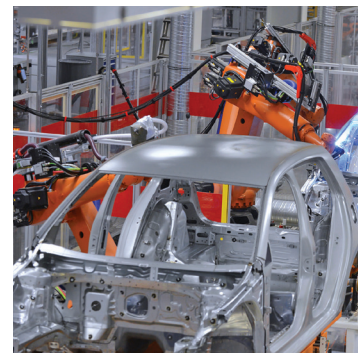

ENGINEERING YOUR SUCCESS.

PXM Pilot Exhaust Module (for the H Series ISO Valve Manifold)

Customer Value Proposition:

PXM Pilot Exhaust Module enables an H Series HA valve to control the pilot pressure to other externally piloted H Series ISO valves in the same manifold zone. The PXM module removes the pilot pressure to these valves while maintaining main supply pressure in the manifold. This creates a pneumatic controlled safety zone without removal of PLC electrical signals or main supply pressure in that zone which provides a host of benefits for enhanced control, additional safety control and maintenance flexibility.

PXM Pilot Exhaust Sandwich Accessory

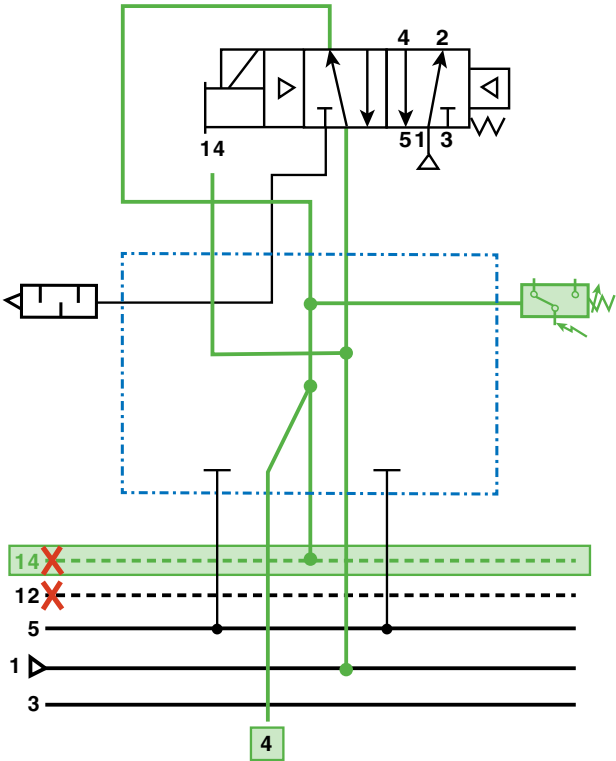

A single solenoid HA valve mounts on top of the PXM pilot exhaust module. It is the first valve and works in conjunction with the PXM to control pilot across other valves in the manifold.



The PXM connects main supply pressure in the HA valve to the 14-pilot manifold galley when the 14 solenoid is energized.

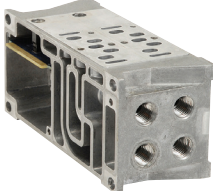

The manifold maintains supply pressure but waits for pilot signal to actuate the externally piloted valves in the pressure zone. [Port 2 is disabled, while port 4 of the valve is connected to main supply pressure. This port can be blocked or connected to other functions.]

All externally piloted valves (of any size) in the manifold zone are operational provided solenoid 14 of the HA valve on the PXM is energized (on). The HA valve in conjunction with the PXM will remove pilot pressure to all externally piloted valves in the manifold zone when solenoid 14 is de-energized (off). Control of all externally piloted valves in the zone is disabled for both solenoid actuation and manual override until solenoid 14 of the HA valve on the PXM is energized again (on).

When pilot pressure is removed valves will perform as follows;

- A 5/2 single solenoid (mechanical spring return) valve will return to the 12-operator state
- A 5/2 double solenoid valve will maintain last state
- A 5/3 valve will return to the center condition

To configure or for more information visit us at www.parker.com/pdn/PXM

PXM Pilot Exhaust Module (for the H Series ISO Valve Manifold)

Pressure Zoning:

- **Multiple pressure zones** can be created combining individual manifold segments with alternative manifold gaskets and the intermediate air supply module. These zones can be designed to meet different application and safety requirements on the machine.
- Inserting the PXM Pilot Exhaust Module into a one of these zones allows control of pilot pressure for the entire zone (or manifold).

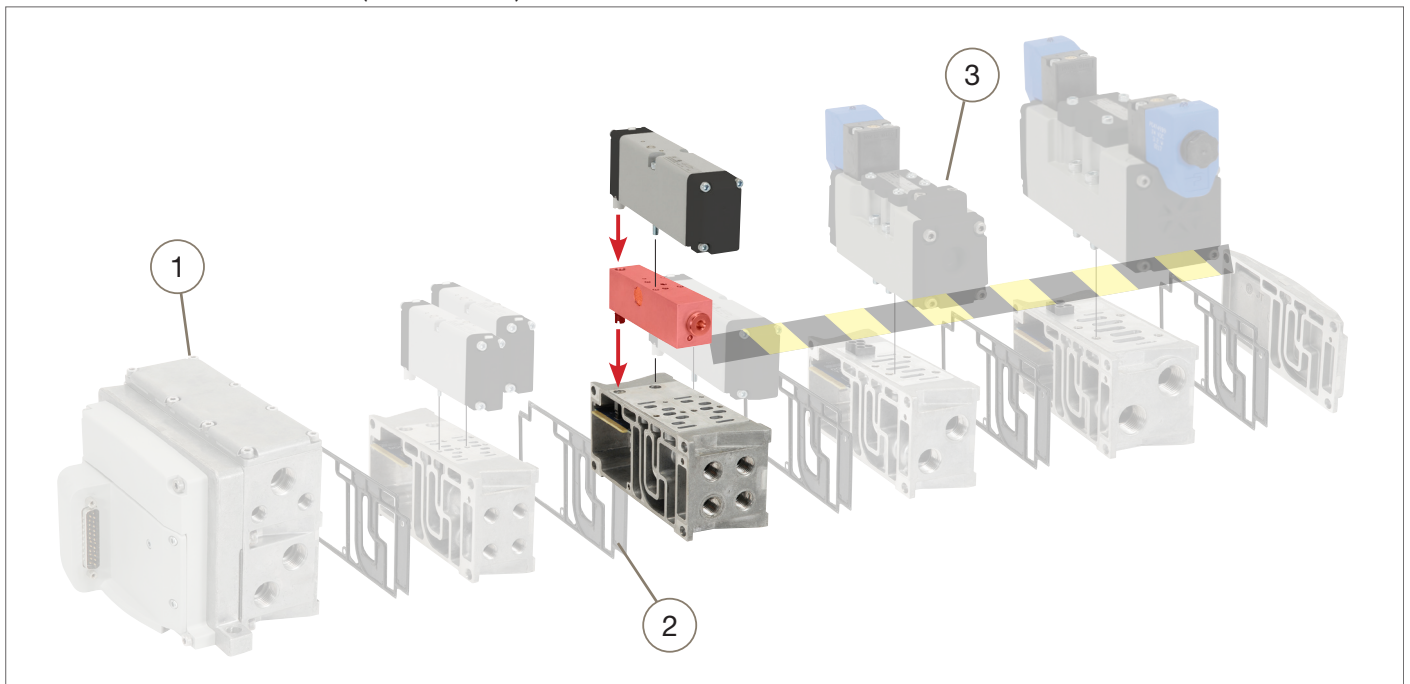

The End Plate or Intermediate Air Supply Module (1) can be configured as internal or external pilot.

Gaskets for blocking pilot pressure are required at the start of the zone the PXM is controlling. Special zoning gaskets (2) are available to meet any application requirement. In this example, main pressure and exhaust pass through to the second zone, but pilot pressure is blocked. This results in the PXM providing pilot pressure for the zone after this gasket.

Valves (s) used with the PXM can be plug-in or non plug-in style (3). Plug-in valves are shown above.

Application

The PXM can be used in safety applications as well as for maintenance while one zone is without pilot pressure the other parts of the machine are functional and supply pressure is not dumped. Pilot pressure control is shown in one section of a zoned manifold for enhanced safety on machine. Always follow machinery directives to achieve the required level of safety. The PXM is not a certified safety component but when integrated properly can be an integral part of a safety circuit.

To configure or for more information visit us at www.parker.com/pdn/PXM

ENGINEERING YOUR SUCCESS.

PXM Pilot Exhaust Module (for the H Series ISO Valve Manifold)

Pilot Exhaust Module Standard (no switch)



PS5XXA0P

Enhanced control is achieved by ordering your valve manifold with a PXM Module to turn the 14 pilot off (exhausts pilot) or on (pilot is pressurized) as needed across a zoned section of manifold. Pilot pressure can control the shut down of several valves in one zone or an entire manifold for added safety.

Pilot Exhaust Module with Mechanical Pressure Switch



PS5XXM0P

Mechanical Pressure switch provides feedback to the PLC on the status of pilot pressure to the zone.

The mechanical pressure switch is galvanized steel construction. Designed for general purpose industrial applications it is rated for 10^6 switching cycles.

Electrical connection is achieved with a 24V DC or 48V AC single M12x1 electrical cable (not included).

Pilot Exhaust Module with Solid State Pressure Switch



PS5XXE0P

Solid state pressure switch provides the added reliability of solid-state components for feedback to the PLC on the status of pilot pressure to the zone.

The solid state pressure switch is hermetically sealed with no moving parts. Designed for robust applications this 17-4 stainless steel switch is rated for 10^8 switching cycles.

Electrical connection is achieved with a 6-40 volt single M12x1 electrical cable (not included).

Ordering

The PXM Pilot Exhaust Module is offered in three distinct styles with 1/8" BSPP port size.

M12 x 1 Pin Out

1. V supply
2. Digital Comms.
3. Ground
4. Switch Output

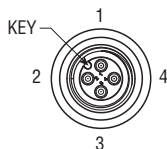

Part Number	Sensor Type	Pressure Port
PS5XXA0P	No switch	1/8" BSPP
PS5XXM0P	Mechanical pressure switch	1/8" BSPP
PS5XXE0P	Solid state pressure switch	1/8" BSPP

Part Number	Cable Type	Pin Configuration
RKC4.4T-2	M12 cable, PVC, 2m	4 Pin female, flying leads



Parker Hannifin Corporation

Pneumatic Division

8676 E. M89

Richland, MI 49083 USA

Tel: 877 321 4PDN

Applications Engineering: pdnapps@parker.com

Customer Support: pdncustsvc@parker.com