



CRYOGENIC PROPORTIONAL RELIEF VALVES

Cryogenic Proportional Relief Valves
for Boil-Off Gas Management

PROPORTIONAL RELIEF VALVES

Overview

Parker Cryogenic Proportional Relief Valves are designed to protect hydrogen and LNG storage tanks from overpressure, gradually reducing pressure and effectively managing boil-off gas. When the upstream pressure exceeds the closing force exerted by the valve's spring, the lower stem opens, permitting flow through the valve's outlet port, where it can be recaptured or released to the atmosphere. The flow rate increases proportionately to the upstream pressure increase.

Each relief valve is characterized by a set pressure, which marks the point at which the valve begins to open to discharge excess pressure in the tank. The Parker Cryogenic Proportional Relief Valve is designed with an accuracy of $\pm 3\%$, meaning it starts to open within $\pm 3\%$ of the set pressure limits.

Upon the release of excess pressure, the valve returns to its closed position (reseats), preventing the wastage of expensive cryogenic gases. The valve will close at a pressure no lower than 85% of the set pressure.

Function:

- Prevents over-pressure

Applications:

- Liquefaction plants
- Bulk storage of liquified gases
- Transportation of liquified gases
- LNG/LH2 refueling stations

Valve size	DN 5
Maximum Working Pressure (MWP)	146-360 psi 1000-2503 kPa
Working temperature	-253°C to + 85°C
End connections	A-LOK®, CPI™
Body materials	316 Stainless Steel
Suitable for media type	Group 1 gases Cleaned for oxygen service
Design and testing standards	BS EN ISO 4126, BS EN 13648-1
Approvals	PED approved
Marking	CE marked

The balanced bellows design of the proportional relief valve is a crucial feature that ensures consistent valve operation regardless of back pressure changes. This design employs a unique mechanism to balance the forces within the valve, maintaining a consistent output even under fluctuating pressure conditions.

A low-friction stem seal design reduces friction, enhancing the accuracy of cracking pressure and reseal pressure.

Each valve is individually factory-set to the required set pressure, clearly marked on the body, tested, and stamped with the date of manufacture and a unique serial number before dispatch. All valves are supplied protected with a tamper-proof seal.

Parker Cryogenic Proportional Relief Valves are available with fully integrated A-LOK® or CPI™ inlet and outlet connections for leak-free operation.

The valve must be installed vertically to ensure optimal performance.



Features, Benefits and Values

Reference	Feature	Benefit	Value
1	Balanced bellows	Stable operation irrespective of back pressure changes	Safety Performance Reliability
2	Integral A-LOK®/ CPI™ compression tube ends	Leak-free operation No special tools required for installation	Safety Ease of operation Reliability
3	Anti-tamper operation	Protection from unauthorized tampering	Safety
4	Mounting holes	Convenient installation Flexible placement	Ease of operation Reliability
5	Tip low friction polymer (reseat design)	Repeatable performance Prevents sticking	Safety Performance Lower overall cost
6	Best-in-class Opening/Closing accuracy level	±3% Opening and Closing accuracy levels for precise control of flow	Performance Safety

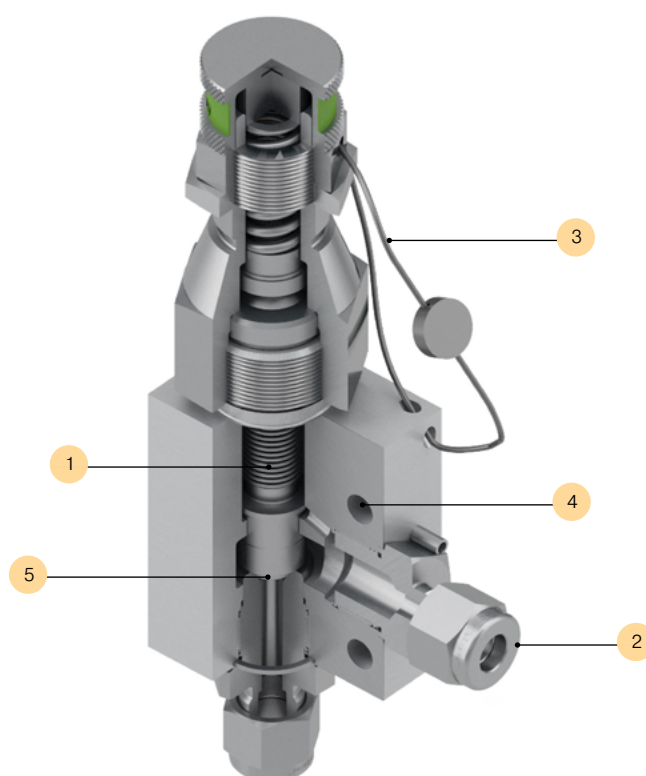

Technical Information

Bill of Materials

	Description	Material
1	Body	Stainless Steel ASTM A479 Grade UNS S31600/S31603
2	Seat	Stainless Steel ASTM A479 Grade UNS S31600/S31603
3	Outlet Adaptor	Stainless Steel ASTM A479 Grade UNS S31600/S31603
4	Stem Tip	Stainless Steel ASTM A479 Grade UNS S31600/S31603
5	Stem	Stainless Steel ASTM A479 Grade UNS S31600/S31603
6	Bellows	Stainless Steel BS EN 10088-3 1.4404
7	Bonnet	Stainless Steel ASTM A479 Grade UNS S31600/S31603
8	Joint Seal	Stainless Steel ASTM A479 UNS S31600
9	Weld Flange	Stainless Steel ASTM A479 Grade UNS S31600/S31603
10	Locking Wire & Puck	Galvanised Steel Wire & Lead
11	Shaft Cap	Stainless Steel ASTM A479 Grade UNS S31600/S31603
12	Spring	Stainless Steel BS EN 10270-3 1.4401
13	Panel Nut	Stainless Steel
14	ID Sticker	Vinyl
15	Swash Plate	Stainless Steel ASTM A479 Grade UNS S31600/S31603
16	Adjusting Cap	Stainless Steel ASTM A479 Grade UNS S31600/S31603
17	Nut and Ferrule Kit	Stainless Steel ASTM A479 Grade UNS S31600/S31603

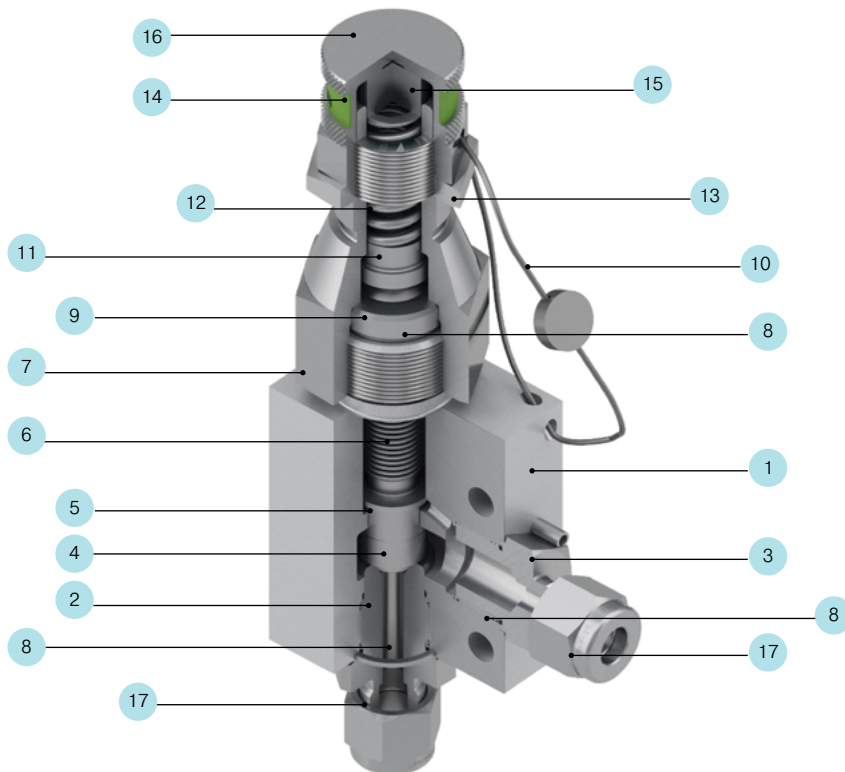



Parker Hannifin Manufacturing Ltd.
Instrumentation Products Division Europe
Pottington Business Park | Riverside Road
Barnstaple, EX31 1NP | United Kingdom
www.parker.com/ipd

September 2025

Your Local Authorized Parker Distributor

© 2025 Parker Hannifin Corporation

