

Parker Balston® Flame-Proof Zero Air Generator Model 75-82EU, 75-82EU-220

Installation, Operation, and Maintenance Manual

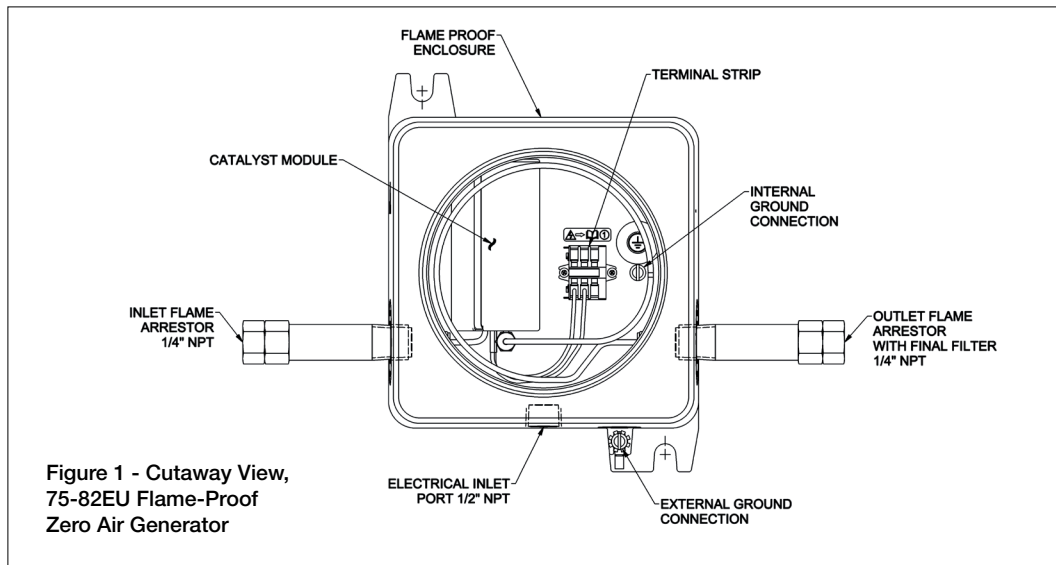
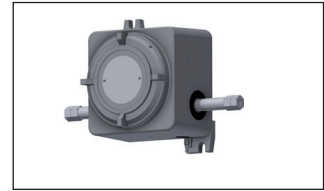

These instructions must be thoroughly read and understood before installing and operating this product. Failure to operate this product in accordance with these instructions could present a safety hazard to the user and will void the safety certification of this product. Modification of the unit will result in voiding the warranty. If you have any questions, please contact your local representative. Send email to: GSFOrders@parker.com.

Please save product packaging for future use.

System Description

The Parker Balston 75-82EU Flame-Proof Zero Air Generator is ATEX and CSA certified. The ATEX and CSA markings are displayed on the product label on the cover of the unit.

The 75-82EU will remove hydrocarbons from on-site compressed air to a total concentration of less than 0.1 ppm (measured as methane) at a flow of 1000 cc/min. and with a 100 ppm challenge, the 75-82EU-220 at a flow of 1000 cc/min with a 100 ppm challenge. The Flame-Proof Zero Air Generator may be used to produce fuel air for a Flame Ionization Detector (FID) or as a zero reference for any process instruments measuring hydrocarbon concentration.

The Parker Balston 75-82EU is comprised of: an Flame-Proof enclosure; inlet and outlet flame arrestors; a catalytic oxidizer to remove hydrocarbons from the compressed air; and a final filter in the outlet flame arrestor to remove particulates from the emergent zero-grade air. All internal components of the 75-82EU are stainless steel to resist corrosion in the most severe environments.

Two versions of the Parker Balston Flame-Proof Zero Air Generator are available to meet world-wide electrical power supply specifications. The systems available are compatible with 120VAC/60 Hz and 230VAC/50 Hz. Please see the ordering information on page 4 of this bulletin for further information.

Catalyst Module

The catalyst module (see Figure 1) is a stainless steel vessel filled with catalyst and assembled with a cartridge heater. This assembly oxidizes hydrocarbons in the compressed air supply to water and carbon dioxide. The catalyst module is precisely engineered to produce zero-grade air up to a maximum flow rate of 1000 cc/min. without the need for a temperature controller.

Final Filter

The generator is equipped with a final filter which removes particulate contamination from the outlet zero-grade air. This filter is a 20 micron stainless steel filter cartridge.



ENGINEERING YOUR SUCCESS.



To prevent explosion and serious injury, the Parker Balston 75-82EU Flame-Proof Zero Air Generator must be installed by a licensed electrician according to ATEX regulations. Only one electrical entry is allowed. Use a certified cable gland to flameproof "d", dust ignitions protection "tb" and a minimum IP66 rating. All connecting wiring for the 75-82EU must be made according to EN 60079-0 and EN 60079-1. To prevent ignition, all conduit runs must have sealing fittings connected within 1 1/2" of the enclosure. Keep cover tightly closed while the unit is in operation.

All installation, operation, and maintenance activities for the Parker Balston 75-82EU Flame-Proof Zero Air Generator should be performed by suitable personnel using reasonable care.

Location

The Parker Balston 75-82EU Flame-Proof Zero Air Generator should be located in the vicinity of the instruments which are being supplied with zero air from the unit. Care should be taken to protect the unit from severe weather conditions. The unit is rated for Ingress Protection IP54, dust-protected and splashed water. There is no limit to the distance between the generator and the point of use as long as the tubing material, cleanliness, and pressure drop are taken into consideration. The zero air generator must be located in an environment where the ambient temperature is between -4°F and 140°F (-20°C and 60°C).

The 75-82EU is designed to be wall-mounted. The generator must be installed to a flat rigid surface using the two mounting feet. The unit must be mounted in the vertical position as shown in Figure 2. Do not install the unit in the horizontal position or the integrity of the zero-grade air will be compromised. The mounting holes located on the unit should be used to secure the unit to a wall using National Electrical Code (NEC) and local building code guidelines. All mounting hardware should be adequately sized to hold the weight of the 75-82EU in place where mounted.

Utilities

Compressed Air - The 75-82EU Flame-Proof Zero Air Generator should be supplied with instrument-grade compressed air at a pressure and flow rate above that required at the point of use. If instrument quality air is unavailable, care should be taken to supply clean compressed air with a temperature and/or dewpoint at or below ambient temperature. Supply the compressed air to the 75-82EU through the 1/4" NPT female inlet port on the left side of the unit (see Figure 1). There is no prefiltration provided with the 75-82EU. If the compressed air which feeds the 75-82EU is of inferior quality, Parker Hannifin recommends the installation of a prefilter (P/N 2002N-1B1-BX) upstream from the unit.



Note: The hydrocarbon catalyst module can be contaminated by high concentrations of lead, sulfur, or phosphorous compounds, heavy metals, chlorinated hydrocarbons, chlorofluorocarbons, and long chain polymers. Care should be taken to avoid introducing these compounds into the Zero Air Generator. Specifically, assure that none of these compounds are stored near the inlet to the compressor supplying the system with compressed air. The intake for the compressor should be vented to the outdoors.

Power - The electrical requirement for the 75-82EU is 120 VAC/60 Hz, 0.5 amp. The electrical requirement for the 75-82EU-230 is 230 VAC / 50 Hz, 0.25 amp. The electrical port of entry is 1/2" female NPT. The internal ground connection is provided with a stainless steel #10-24 phillips head screw. The external ground connection is provided with a #10-24 thread stainless steel screw with external tooth lock washer, and crimp ring connector

Note: Do not install this product on a ground fault interrupt circuit (GFI). Generator electrical characteristics may cause the GFI to trip during operation.

Tubing - The outlet port of the Parker Balston 75-82EU Flame-Proof Zero Air Generator is 1/4" female NPT and is located on the right side of the unit (see Figure 1). Tubing that is used downstream from the Zero Air Generator should be clean stainless steel or pre-cleaned refrigeration-grade copper tubing (1/4" O.D. x .030" wall). Do not use plastic tubing downstream from the 75-82EU. Outgassing from the plastic may contaminate the zero air. Use PTFE tape on all inlet and outlet NPT fittings. (Thread sealing compounds may contaminate the process stream.) All connections to the 75-82EU should be suitable for use at 125 psig (8.6 barg) and 1000 cc/min.

If pre-cleaned copper tubing is unavailable, standard copper tubing may be cleaned by the customer. First, connect the tubing to a supply of clean inert gas (N₂, He). Next, initiate the gas flow through the tubing (5-10 cc/min.). Finally, heat the tubing with a propane torch, moving the flame at a rate of approximately 1/2 in./sec. in the direction of flow. This procedure removes waxes and oils used in the manufacture of the copper tubing.

Recommended Accessories (see Figure 3)

2002N-1B1-BX - If prefiltration of the compressed air is required, an appropriate filter arrangement should be selected to fit the pressure and flow characteristics of the incoming air. The Parker Balston 2002N-1B1-BX filter assembly is ideal for removing oil, water, and particulate matter from the compressed air supply.

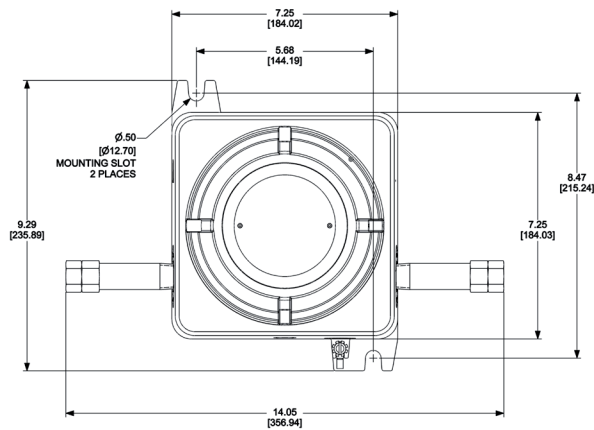

Figure 2 - 75-82EU Mounting Dimensions and Orientation

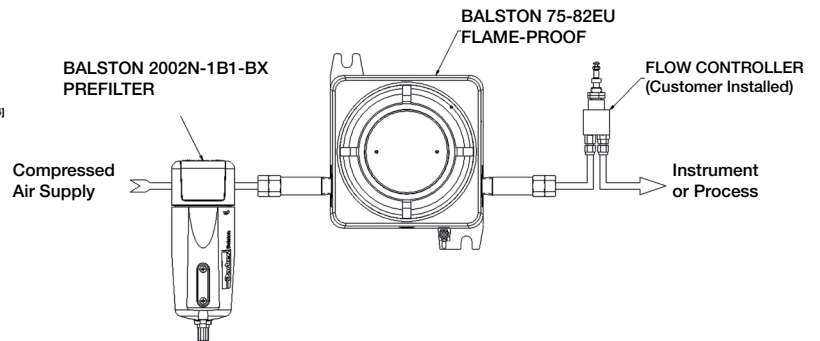

Figure 3 - 75-82EU Recommended Installation

Operation

Start-up

Initiate the flow of compressed air to the generator and adjust the inlet pressure to the desired setting. The maximum inlet pressure is 125 psig (8.6 barg). Set the flow through the generator to 1000 cc/min. If the 75-82EU is operated at a flow rate greater than 1000 cc/min., the unit may not perform to specifications. It will take the 75-82EU approximately 45 minutes to achieve the outlet purity specification of less than 0.1 ppm hydrocarbons. The Parker Balston 75-82EU Flame-Proof Zero Air Generator is designed to run continuously for 24 hours per day.



Warning: Do not supply electrical power to the generator until the compressed air flow rate through the unit is at the rated capacity (1000 cc/min.). Operating the generator for extended periods of time without compressed air will damage the heater within the catalyst module and void the warranty.



Warning: Do not remove cover when operating.

Maintenance



To avoid explosion and serious injury, service must be performed by qualified service technicians. Disconnect the power, depressurize, and allow the 75-82EU to cool for 2 hours before opening the generator and servicing any internal components.

All maintenance activities should be performed by suitable personnel using reasonable care.



ALL FLAME JOINTS IN THIS EQUIPMENT ARE NOT TO BE REPAIRED.

Pre-filter Maintenance

Any filter which has been installed upstream of the 75-82EU should be checked regularly. If the Parker Balston 2002N-1B1-BX is installed as a prefilter, change the filter cartridge annually (P/N 100-12-BX). If the filter cartridge clogs often with particulate matter or drains water at very short intervals, an additional stage of prefiltration should be installed. Changing the filter cartridge on the Parker Balston 2002N-1B1-BX takes approximately 15 minutes.

Final Filter Maintenance

The final filter cartridge should be replaced every two years or as needed to maintain flow characteristics. When the outlet flow diminishes to an unacceptable level, replace the final filter. The final filter is located inside the outlet flame arrester. It is easily replaced by disconnecting the outlet tubing. Then, using two 7/8" wrenches (or two adjustable wrenches), unscrew the right-hand portion of the outlet flame arrester and remove the sintered element and spring. Replace the spent sintered element with a new one (P/N 13299) and reassemble putting the element in first, followed by the spring. Dispose of the spent element according to local regulations.

To ensure consistent product performance and reliability use only genuine Parker Balston replacement parts and filter cartridges.

The catalyst module will need to be replaced approximately every 2 years. Installation of the replacement module (P/N 75398 or 75398-220) requires less than 30 minutes. First, shut off the power to the unit. Next, after the 75-82EU has depressurized and cooled (2 hours, minimum),

Catalyst Module Maintenance

remove the front cover. Disconnect the catalyst module electrical connections from the terminal strip inside the unit (see Figure 1). Use two 7/16" wrenches to disconnect the inlet and outlet compression fittings from the catalyst module. Install the replacement module in the reverse order, tightening the 7/16" connections 1/4 turn beyond finger tight. (For ease of installation, connect the inlet fitting first.) Finally, leak test the 75-82EU after installing the replacement catalyst module.

Replacement Parts

Description	75-82EU	75-82EU-220
Replacement Catalyst module	75398	75398-220
Final Filter (sintered element)	13299	13299
Spring	B01-0068	B01-0068

Note: To ensure consistent product performance and reliability, use only genuine Parker Balston replacement parts and filter cartridges.

Optional Accessories

Description	Model Number
Prefilter Assembly	2002-1B1-BX
	75-82EU/75-82EU-220 to reflect shared max flow rate.

System Specifications

EU_Directive	2014/34/EU
ATEX Standards	EN 60079-0:2017, EN 60079-1:2014, ISO/IEC_80079-34:2011
ATEX Marking	11 2 G Ex db IIB +H ₂ T6, Gb
HazLoc Standards	CSA C22.2 No.30:2020 Ed.4, UL 1203:2023 Ed.6
HazLoc Marking	Class 1, Division 1, Groups B, C, and D
Ambient Temperature	-4°F to 140°F (-20°C to 60°C)
Maximum flow rate	1000 cc/min.
Total hydrocarbon concentration (100 ppm Challenge)	<0.1 ppm (<0.1 ppm)
Min./Max. inlet pressure	40 /125 psig (2.8/8.6 barg)
Maximum inlet hydrocarbon content	100 ppm
Maximum inlet air dewpoint	10°F above ambient (5°C above ambient)
Pressure drop at max. flow rate	<8 psig (<0.6 barg)
Start-up time	45 min. (45 min.)
Electrical requirements	120VAC/60Hz, 0.5 amp (230VAC/50Hz, 0.25 amp.)
Shipping weight (NET)	17 lbs. (12 lbs) (7.5 kg (5.5kgs))
Physical dimensions	14"w x 9"h x 6"d (34cm x 23cm x 15cm)

Don't Forget To:

- 1 Keep your product certification in a safe place.
- 2 Contact your local representative with any questions, or email at: pagservicesupport@parker.com.

Serial Numbers

The serial number for the unit is engraved on the bottom of the label on the front cover. For your own records, and in case service is required, please record the following:

DATE IN SERVICE _____ SERIAL NO. _____

Please have the serial number available when calling for assistance.

