

Good Things COME IN Small Packages

John Rennockl, Parker Hannifin, explains how a busy cement terminal in the southern United States was able to reduce dust emissions from its conveyor system.

A cement terminal on a busy river in the southern United States was experiencing dust emissions from two belt conveyors (BC-1 and BC-2) and transfer points on the shipping dock.

Belt conveyor BC-1 receives cement from a barge unloader that travels the length of the dock (Figure 1). The barge unloader discharges onto belt BC-1 through a chute (Figure 2, yellow arrow) that travels on top of the belt.



To keep rain and wind out of belt conveyor BC-1, a cover was installed on top of the belt. This cover lifts off the belt so that the mobile chute can pass underneath the cover. Although this cover is reasonably tight, some smaller openings are inevitable. On windy days, wind enters through these openings and in the past, has pressurised the belt and created dust emissions, especially in the area

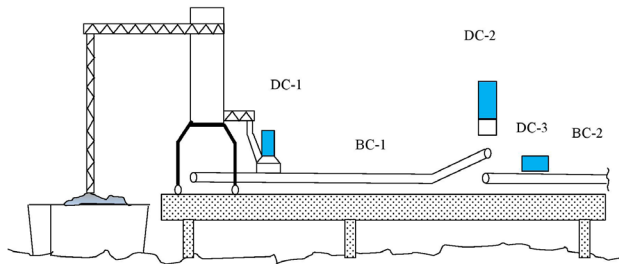

Figure 1. Flow diagram. Shipping dock with two belt conveyors (BC-1 and BC-1).

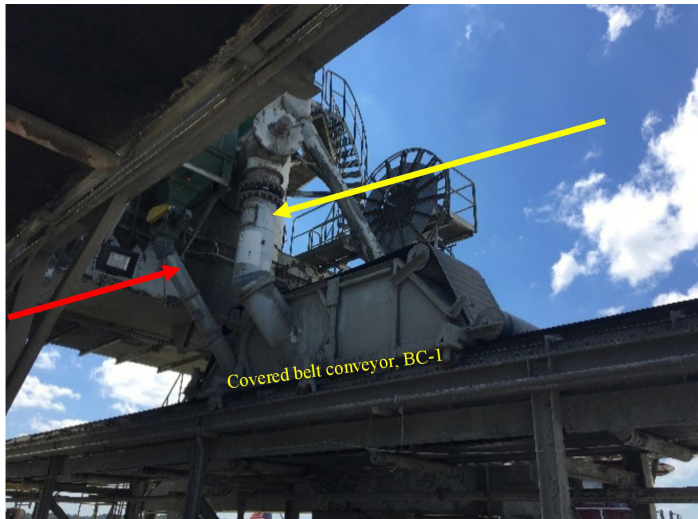

Figure 2. Loading chute on BC-1 (yellow arrow) and old dust collector discharge duct (red arrow).

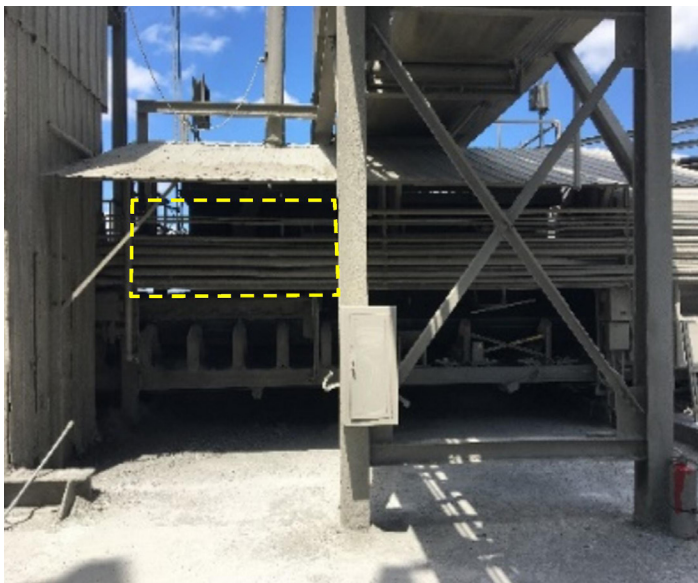

Figure 3. BC-2 available space for collector installation.

around the loading chute and at the discharge of the belt BC-1.

The client contacted Parker Hannifin's Industrial Air Filtration Group, formerly BHA® and a review by one of the system engineers found the following:

- ▶ The moving loading spout that discharges onto the covered belt on the dock was vented by an undersized dust collector. Dust emissions were heavy in this area. The material discharge duct (Figure 2, red arrow) from the undersized dust collector was at an insufficient angle and frequently plugged.
- ▶ A dust collector at the discharge of the covered belt conveyor BC-1 was undersized and its hopper plugged frequently. Dust emissions were common in this area, especially around the loading zone of the downstream conveyor belt BC-2 (Figure 3).
- ▶ There were no large gaps in the enclosure of the covered belt conveyor nor the downstream belt conveyor. However, the wind was getting into the enclosures, pressurising the belt enclosures and transfer points. Positive pressure inside the belt enclosure was confirmed during the inspection. All equipment, including the dust collectors, were offline and wind speed was an estimated 10 – 15 MPH. When the inspection door at the belt discharge was opened, air blew out of the opening. Enclosures of transfer points that handle dry and dusty materials need to be kept under negative pressure to avoid dust emissions.
- ▶ There were no baffles or curtains inside the belt enclosures or near the loading zones to impede wind-induced air currents.

In summary, the dust collection systems were not capable of preventing dust emissions from the vented equipment. An economical and technically sound solution was found by analysing the following points:

- ▶ Required ventilation capacity
 - » Sufficient ventilation volume needs to be extracted from the enclosures to keep the material transfer points under negative pressure, even under windy conditions. The negative pressure generates airflow into the enclosure and prevents dust from escaping. This is especially important in material transfer areas where dust stays suspended. The velocity of the air drawn into the enclosure is called capture velocity. For cement dust at ambient temperatures, capture velocity is typically 1 m/s but it could easily double if the material falls

from greater heights, i.e. has higher kinetic energy or if the transferred material is hot.

- » Openings in enclosures should always be kept to a practical minimum. The smaller the openings, the easier it is to maintain negative pressure inside the enclosure. Where belt conveyors enter and exit the enclosures, flexible curtains can significantly reduce the opening size. Smaller openings mean smaller ventilation volume. By reducing opening sizes one also reduces the additional volume generated by wind entering the enclosures. The additional ventilation volume created by

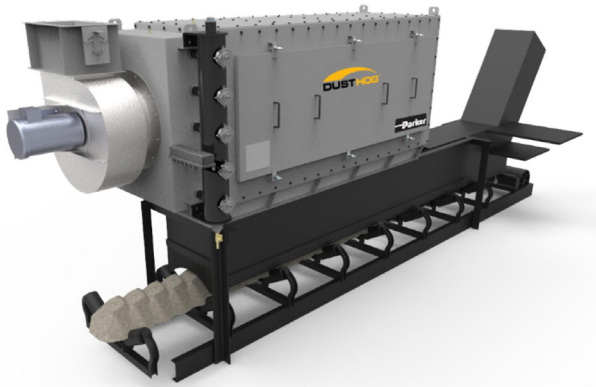

Figure 4. Parker DustHog CFS.



Figure 5. Customised new dust collector on top of BC-1 loading chute.

wind entering the enclosures needs to be included in the design capacity of the dust collection system.

- ▶ Space restrictions
 - » Space is often limited when new equipment is installed in existing installations. In this project, the space above the mobile loading chute on belt conveyor (BC-1) and the loading zone on belt conveyor (BC-2) had limited space. Figure 3 shows the low overhead clearance above belt conveyor (BC-2) which required the installation of a Parker DustHog® CFS, horizontal collector (DC-3).
- ▶ Ease of maintenance and accessibility
 - » New equipment needs to be accessible for maintenance, preferably avoiding new access platforms that could interfere with the mobile ship unloader operation. Ventilation ducts often accumulate dust and this creates maintenance headaches, especially if the ductwork is not accessible for cleaning. Since the barge unloading system is used seasonably, cement would often remain in ventilation ducts for several months and harden. Using bin vent collectors instead of ducted ventilation systems eliminated this problem.
- ▶ Making use of existing equipment
 - » To reduce cost, an existing dust collector (DC-2) located above the discharge of belt (BC-1) and venting it and the loading area of conveyor (BC-2) was reused. However, the collector and its cleaning system were undersized for the required ventilation volume. By converting this collector to a bin vent and dedicating it to just one of the two original ventilation points, the rotary airlock and the constant plugging issues in the hopper and ductwork were eliminated. The airflow through the collector could now be reduced as well and consequently, the cleaning system was able to clean the filter bags. The modification involved the removal of the hopper from the dust collector and the installation of an oversized chute between the discharge enclosure of belt conveyor BC-1 and the dust collector. Since the modified existing dust collector was now no longer venting the loading area of belt conveyor BC-2, a DustHog horizontal dust collector from Parker Hannifin was installed on top of the belt conveyor BC-2. The horizontal dust collector is a low-profile bin vent designed to fit into spaces with low overhead clearances.

A customised solution

The solution to this environmental problem consisted of increasing ventilation volumes

by adding two dust collectors, modifying one existing collector and abandoning another. Baffles and curtains were installed along the length of the belt conveyor and in the loading areas to reduce the effects of wind-induced currents inside the belt enclosure and above the transported material. The structure that houses the material transfer chute from BC-1 to BC-2 was enclosed to prevent wind from entering and distributing dust from the belts' return idlers.

A ventilation capacity of 6800 Am³h was selected for the loading spout collector DC-1 and the combined ventilation volume for the modified existing dust collector DC-2 and the horizontal dust collector DC-3 was 17 000 Am³h. Because of the above-discussed factors, the total installed ventilation volume for this project was 23 600 Am³h. This is almost twice the volume recommended in leading ventilation handbooks for standard systems.

All three dust collectors are of the bin-vent style and therefore do not have hoppers, airlocks or ductwork which are subject to plugging. Space limitations were addressed by using special BHA PulsePleat[®] filter elements instead of filter bags. This resulted in more compact yet reliable dust collectors despite the increased ventilation volumes.

The mobile loading chute from the ship unloader that discharges onto belt conveyor BC-1 received a

custom-designed dust collector that fits on top of the chute enclosure. The rollers that guide the belt cover were raised and now route the cover over the new dust collector (Figure 5).

Belt conveyor BC-2 that receives material from the discharge of belt conveyor BC-1 is dedusted with a Dusthog CFS horizontal collector (Figure 4). The collector can be accessed from ground level and no additional platform is needed to change its pleated filter elements.

Summary

The new and modified systems have been in operation for two seasons and dust emissions have been virtually eliminated making this relatively small project a big success. ■

About the author

John Rennockl is Sr. Application Engineer at Parker Hannifin's Industrial Filtration Group. Mr. Rennockl holds a BS of Physics and has been working in various engineering and management positions in the cement and ventilation industry for the past 30 years. He has written several technical articles and supports clients in all of the Americas.