



Parflange® F37 for pipe and tube connections |

PARFLANGE® F37 PIPE AND TUBE CONNECTIONS



www.parker.com

Catalogue CAT/4162-8/UK May 2026
© 2026 Parker Hannifin EMEA Sarl. All Rights Reserved.





Approval and Certification requirements

Note! Customer has to specify needed certifications, classifications, testing and inspection requirements precisely when requesting quotation/placing an order.

For your safety!

Under certain circumstances, tube fittings can be subjected to extreme loadings such as vibration and uncontrolled pressure peaks.

Only by using genuine Parker components and following Parker assembly instructions can you be assured of the reliability and safety of the products and their conformity to the applicable standards.

Failure to follow this rule can adversely affect the functional safety and reliability of products, cause personal injury, property damage, and result in loss of your guarantee rights.

Subject to alteration

Table of contents

Introduction..... page 4

General information..... 5

Technical data..... 17

Installation 23

Machines, tooling and equipment 25

Ordering information/Nomenclature 33

SAE 1000 System..... 37

SAE 3000 System..... 59

SAE 6000 System..... 99

ISO 6164 System 139

Pipes and tubes..... 173

High Pressure Connectors Europe

The Tube Fittings Authority:

Performance Plus

Since 1929, Parker Hannifin Corporation has served the marketplace with dependable fluid power technology. Today, Parker offers more than 100,000 quality products for a broad range of industries and applications. No other manufacturer presents a product line as broad as Parker's, nor an expertise as far-reaching in hydraulic and pneumatic systems and components. Much of that expertise originates with Parker's precision-made tube fittings, which were among the first products manufactured by the company. As such, they reflect Parker's ongoing commitment to excellence.

With more than seventy years of experience in product design, engineering, applications technology and manufacturing, the High Pressure Connectors Europe division holds a leadership position few other manufacturers can claim. This leadership is further heightened and enhanced by the sharing of technology only possible in Parker's corporate family.

Topflight Experience

Parker has used the background data and knowledge gained from important industrial, mobile, offshore and other applications to create the broadest and best performing line of standard tube fittings in the world.

Why is Parker a topflight manufacturer of fittings?

There are many reasons, but at the heart is the design and manufacturing excellence that goes into every Parker product.

Worldwide standardizing activities

The Parker Fluid Connectors Group supports the national and international standardizing activities. Experienced engineers from certain countries and Divisions give their input to national committees like SAE, BS, and DIN committees in cooperation with the users of the products. As a result, many ISO Fluid Connector standards have been published. These ISO standards are the platform for the international trading, interchangeability and availability that is necessary for all globally operating companies using fluid power technology.



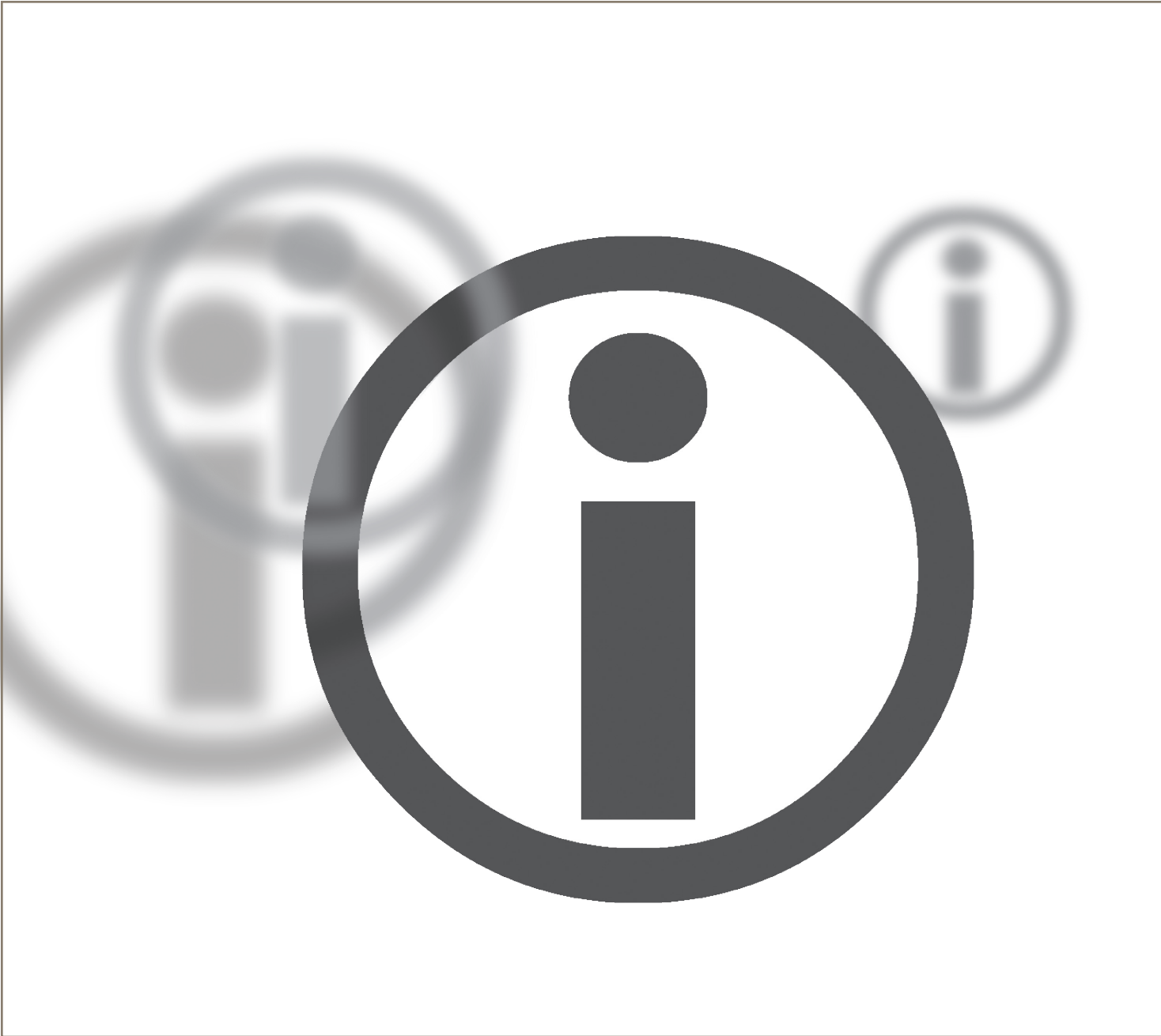

General information

Parflange® F37 technology

Parflange® technology

Parker is the inventor of the Parflange® system and knows well how to deal with flared tubes and flanged connectors. The excellent sealing performance and the high mechanical strength of Parflange® technology are achieved by continuous orbital tube forming. Proven millions of times, this connector system is backed by decades of experience. The Parflange® system belongs to Parker's leak-free Dry Technology programme. Dry Technology stands for leak-free systems with soft sealing at every connection point.

Parflange® F37

The Parflange® F37 flanged connector system is utilising this orbital tube forming technology for tubing assemblies from 16 to 168.3 mm (1/2" to 6" Flanges) outside diameter. It is intended for tube wall thickness up to 9 mm and pressure ratings up to 420 bar.

For those connections, where there is no possibility to assemble a pre-flared tube or where manufacturing is limited, Parker provides the F37 Retaining Ring System. This System utilizes a Retaining Ring for flange retention along with a highly-engineered seal carrier for leak free performance. It is available as a high pressure version from 1 1/2" to 12" and as a 1000 PSI version for lower pressures up to 50-70 bar.

The Parflange® F37 system corresponds to hole patterns according to ISO 6162-1; SAE J518; bore pattern 3000 (code 61), ISO 6162-2; bore pattern 6000 (code 62) and also ISO 6164 bore pattern.

It is type approved by DNV, ABS and other major classification companies.

Protected from corrosion and even Cr(VI)-free

As a manufacturer of large flange connectors, Parker is employing Cr(VI)-free corrosion protection on Parflange F37, as it has already done with its other Fluid Connector Products. The removal of Cr(VI) reflects Parker's ongoing commitment to an environmentally clean and safe production process.

Different Sealing Solution

The F37 seal was developed especially for use with SAE flanges. These special seals guarantee high stability of form. Compared to standard O-Rings, their mechanical properties prevent gap extrusion, even when the flanges "breathe" under pressure. The special profile of the F37 seal is ideally adapted to higher pressures or unsuitable surface finish of the flanges. As an alternative, connectors can be equipped with bonded seal rings.

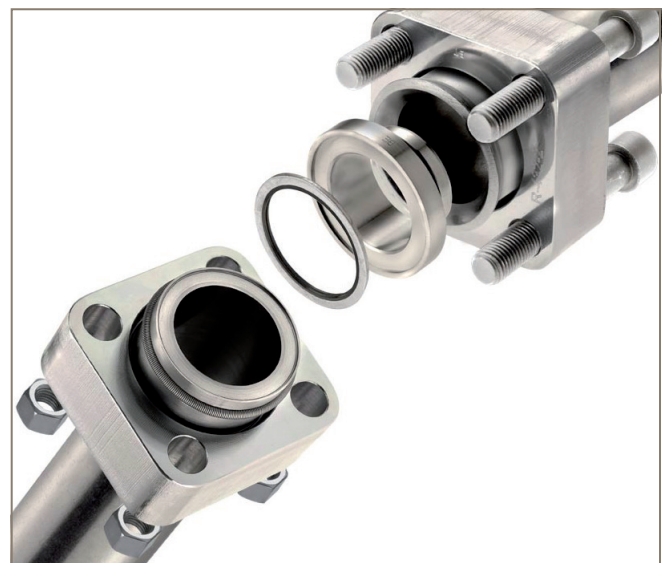
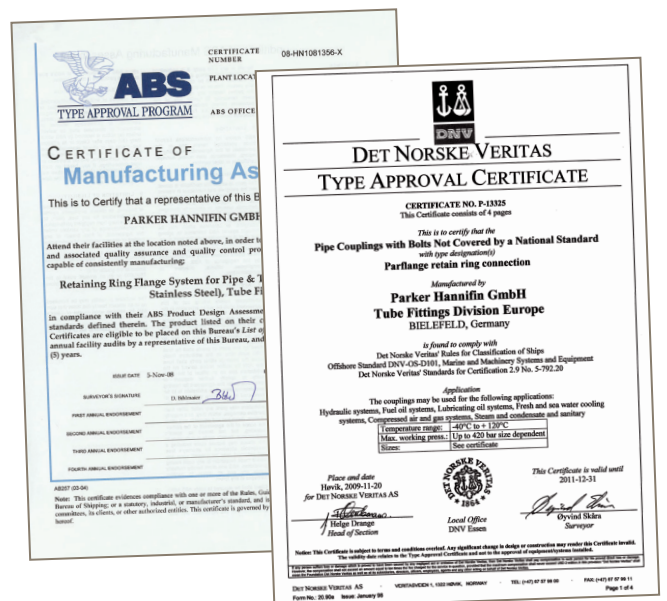
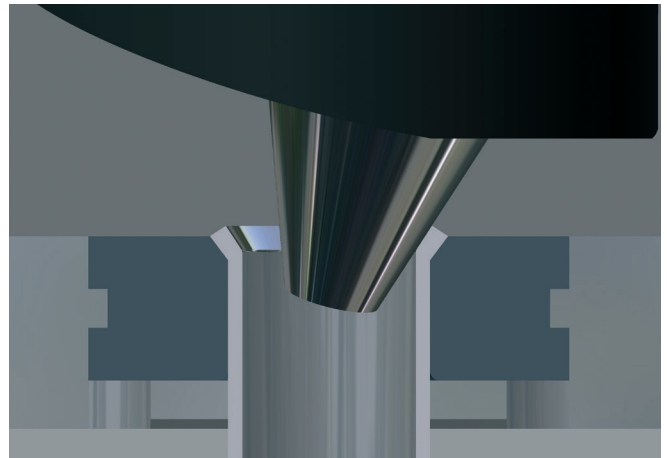

Parflange® F37 technology

Flaring Machine (Adjustable)

For smaller tube connecting projects such as the on-site maintenance of, for example, drilling platforms or ships, the Parflange® ECO for processing steel and stainless steel tube is available.

The machine works to the Parflange® process, proven millions of times over, affording maximum mechanical accuracy and reliability. It does not require any complicated programming or operation to manufacture rapidly smaller quantities up to 168.3 mm outside diameter. The maximum capacity of the machine is around 5 mm wall thickness for a 165 mm tube at a remarkably short cycle time of 30 to 60 seconds for the flaring and 1 to 2 minutes for the total operation. Other tube diameter allow even thicker tube wall.



Complete range for virtually all diameters

The F37 system complements the EO-2 soft sealing technology for small tube diameters; it also complements the proven Parflange® programme for the SAE product range. It offers the complete range of connectors, flange-to-flange, L- and T-Block connectors, flange-to-port, male and female thread flanges, flange bends, reducer flanges, bulkhead flanges and manifolds on request.

The F37-Programme – a savings programme

F37 is the way to reduce manufacturing times enormously. By comparing welded connections with Parker flange connector systems, significant opportunities for cost savings become immediately obvious

1. Cutting and deburring tubes
2. Tube preparation for the “connecting process”
3. Welding and/or assembling
4. Inspection (X-ray) of welded connectors
5. Flushing the connected tubes
6. Applying corrosion protection

In comparison with this, weld-free tube forming save time and costs. Expensive cleaning and X-raying of the tube connector become immediately things of the past. The manufacturing time for a tube connector quickly reduces by more than half in comparison with conventional welding. To make this clear, Parker has developed a calculator which, on the basis of the individual input data, determines the exact cost saving from

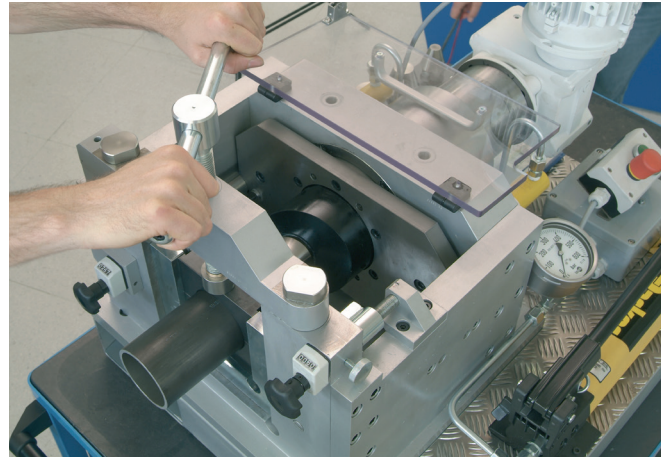

Parflange® F37 technology

using Parflange® F37 and/or the high-performance flange connectors. Parker flange connector systems accommodate even higher requirements, especially those from the offshore industry, shipbuilding, heavy machinery construction and press manufacture, as well as from mining, recycling plants and mobile machinery; overall in power piping systems.

Personnel and environment-friendly

By comparing the individual operations for a welded line with Parker flanges connected lines, significant cost savings opportunities become immediately obvious. No vapours putting health at risk are released, in contrast to conventional welding processes. Consequently, usage is possible in locations with high requirements such as, for example, offshore oil platforms. In addition to this flaring machine design errors in the preparation of flanges are virtually unknown. Stress corrosion cracking generated during welding operations is history and the life of the finished tubing system is increased. Cold formed Parflange® technologies save power and energy compared to welding and require neither degreasers nor anti-corrosion agents. When galvanized tubes are used, post-galvanization can be omitted because the zinc-coating is not impaired by flaring. Parker flange connector components are delivered in state of the art Cr(VI)-free surfaces.

We deliver all the component parts securely packed to the required location. Reliable delivery on the date advised. And then we come to professional assembly – our specialists will willingly take it on for you. After testing and a trial run, you can press the start button to make your production a success.

Principles account for success

The concept of this system is the customer interaction with advice, design, preassembly (with fittings, flanges and machined tubes), delivery and installation as a complete package cannot be beaten. Supportive planning, high-quality products and safe working processes offer the ultimate synergy in time and cost saving. And of course, individual Piping Solutions principles are also available to you.

The Parker Piping Solutions concept principles:	
Advise	Briefing/ Design discussion
Design	Tubing layout Tube dimensioning Drawings Documentation
Pre-assemble	Tube bending Flaring Tube cleaning
Deliver	Assemble/dispatch Documentation
Install	Manufacturing On site management On site assembly Inspect and wash Documentation

Feature	Customer Value
No welding	- Reduced preparation time per joint - No costly inspection of welds (X-ray)
No post-weld cleaning	- No acid cleaning costs - No waste cleaning costs - No safety risk - Environmentally friendly
No welding stress corrosion possible	- Maximum piping lifetime - Reduced maintenance costs
No „hot work“ permit required	- Operation can take place in areas with fire risk without interruption of production - Reduced downtime costs - Higher level of safety
Work shop prefabrication	- High quality joints with better accuracy due to workshop conditions - Minimized need for on-site work - Shorter installation time - Shorter maintenance/downtime - Shorter total project time
Cleanliness	- Minimized need for repair and replacement of hydraulic system components such as pumps, cylinders,... - Reduced overall flushing time and costs
Easy dismantling and reassembling	- Quicker, easier and more flexible installation - Reduced downtime costs for maintenance and repair



Connection technology

The Parflange® F37 Programme consists of two flange connection technologies:
The 37° Flare Flange Connection and the Retaining Ring Connection.

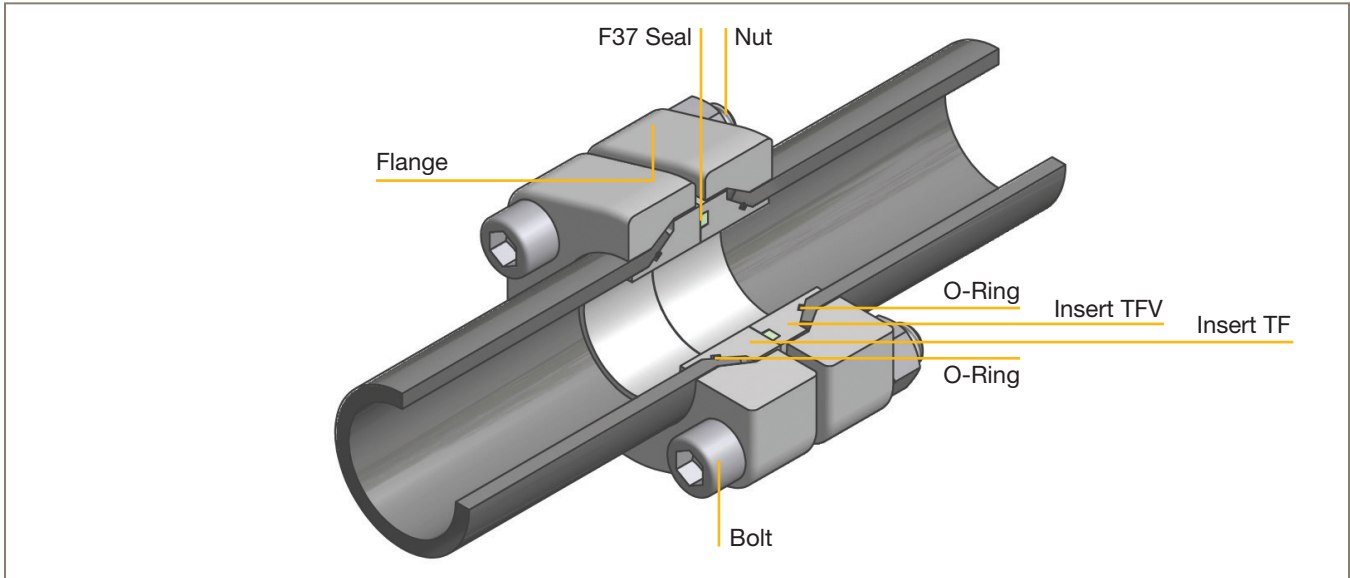

Parflange® F37 Flare Flanges - In this configuration, the deburred tube end is flared orbitally to 37° by Parflange® technology. An insert, soft sealed by an O-Ring, is located into each pipe end. In between a F37 Seal (optionally Bonded Seal or O-Ring) is placed. By tightening the flanges together, a soft sealed, high pressure tube connection is made. Available as tube-to-tube connection or tube-to-port connection.

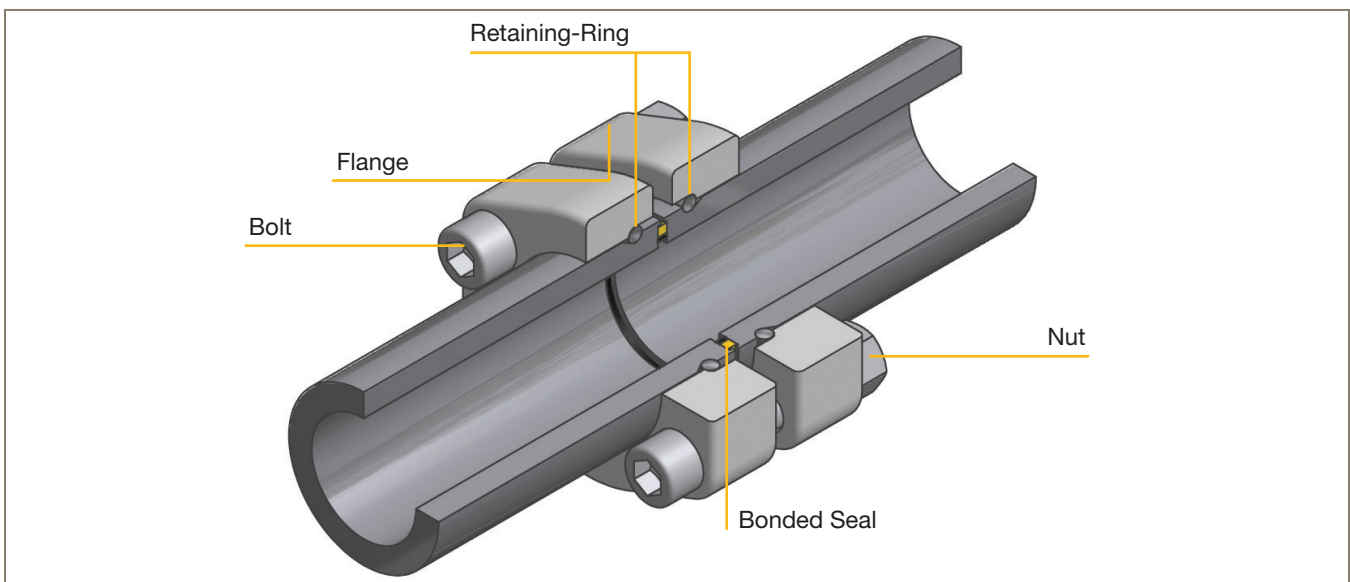

Retaining Ring Connection - The retaining ring used in this connection is a stainless steel segmented ring covered by a stainless steel spring. It is assembled in a machined groove on the tube end or adapter. When tightening this system, the flange is pushed against the retaining ring, thus giving a form tight connection. Retaining ring connections complete the Parflange® F37 range with bulkhead, male, female, weld and tube bend connections.

Connection methods F37 – Flared tube

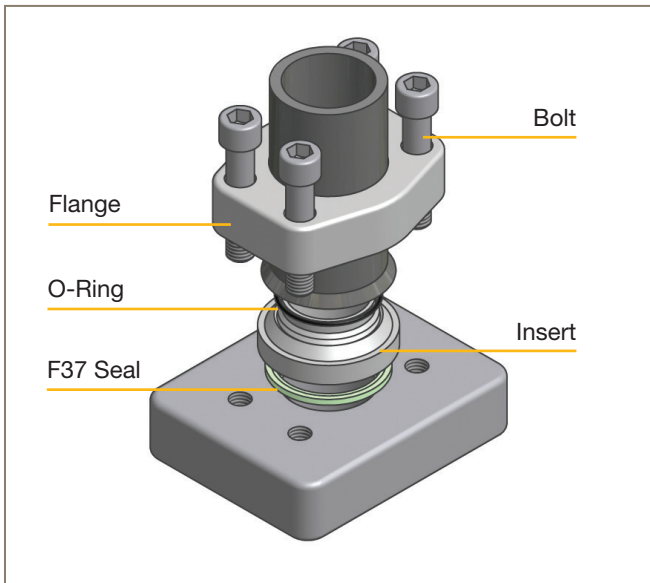

Flange to Port – the flanged tube is connected by the flange, insert and F37 seal to a port. Inserts with Bonded Seal can be used alternatively.

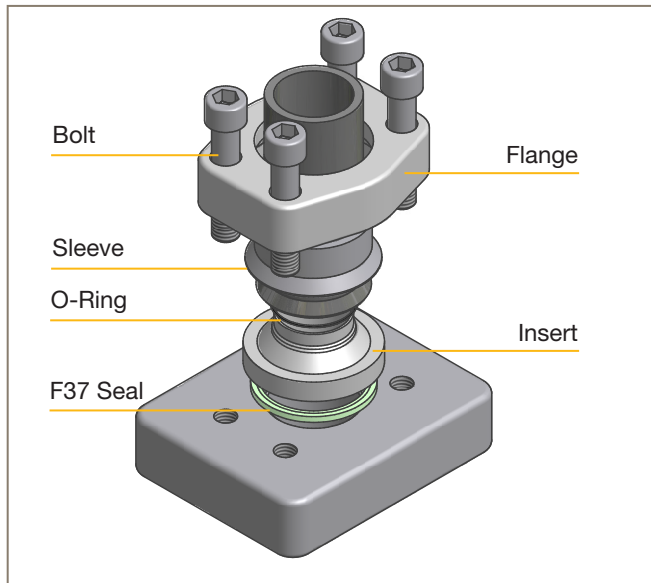

Flange to Port – the standard F37 Flanges can be used with adapter sleeve for smaller tube sizes as well.

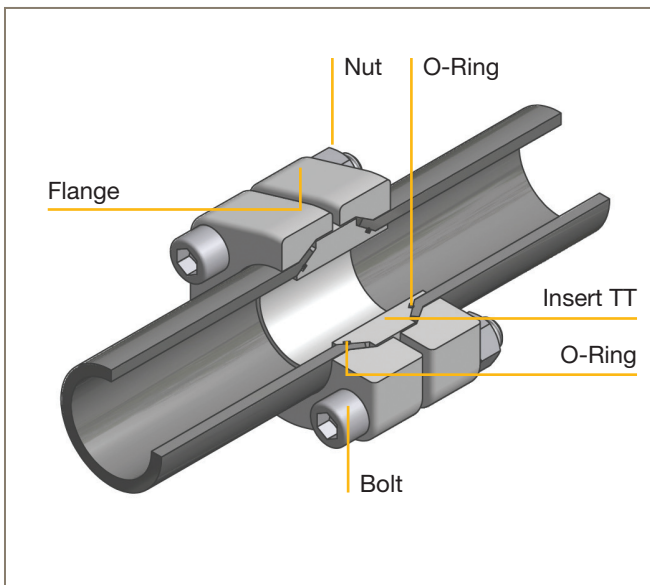

Tube to Tube – two flanges and one insert connecting two flared tubes. A two insert solution with F37 Seal or Bonded Seal is optional.

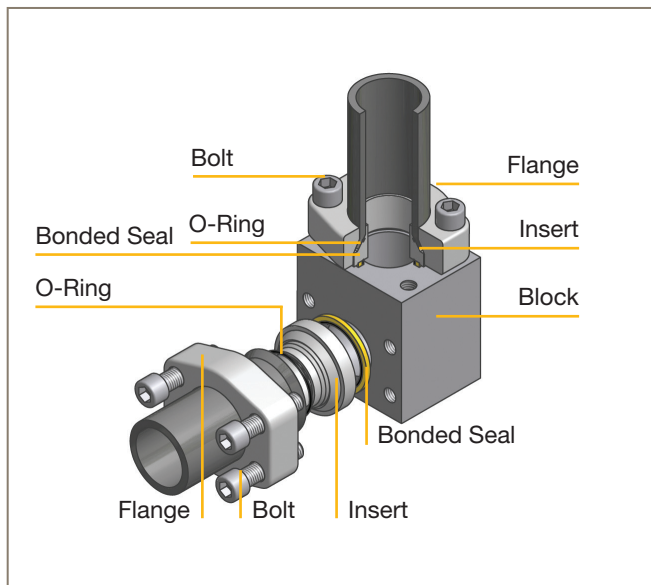

Tube to Block – instead of using flange bends compact L-Blocks are available. The range is completed by T-Blocks and Reducing Blocks. Special Manifolds according to customer design available on request.

Connection methods – Retaining ring

The Retaining Ring Flanges are – like the flanges for the F37 range – according to ISO 6162-1/2 and ISO 6164 footprint. Therefore any combination of the systems is possible.

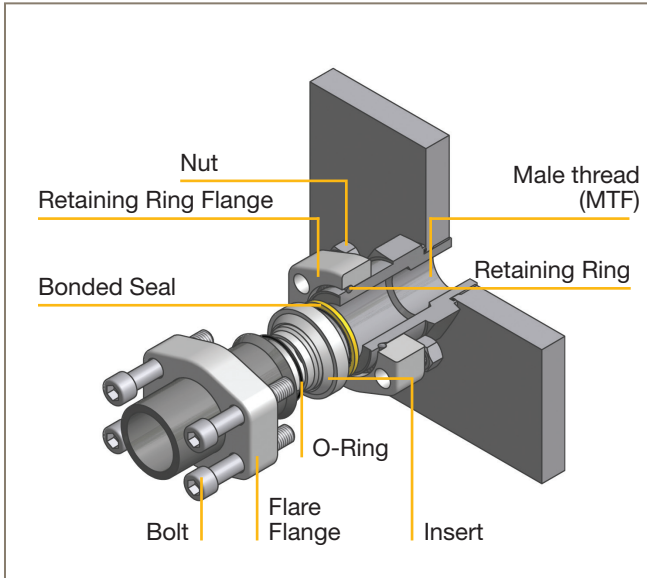

Male Thread Connection – Male Stud ends are delivered with soft seal ED end on one side and the Retaining Ring connection on the other side.

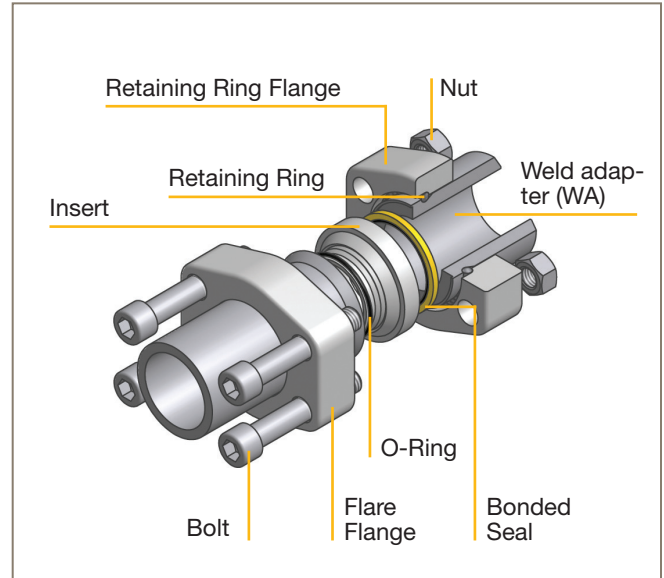

Weld Adapter – Weld adapters are delivered with weld end on one side and the Retaining Ring connection on the other side.

Complete Piping Solutions

Homogeneous solutions offer efficiency

From Components to full service.

Parker offers you the competent complete solution for hydraulic systems. From advice via design and pre-configuring to delivery and installation - everything with the best quality and reliability. You only have one contact. You take the pressure off your own team, release capacity and overall save a lot of time. You achieve new efficiency at high pressure.

Excellent complete solution.

Complete Piping Solutions from Parker are always to the customer's advantage. Equally high quality in all areas and available around the world.

The complete solution from a single source frees up customer capacity and lowers the need for customers to provide coordination effort. As a supplier of piping system solutions we offer our customers significant added value.

Advantages that pay off.

- High-quality system technology
- Saves time
- Saves money
- Customised user solutions
- Environmentally friendly
- Global supply
- Integration into existing systems

Advice	Briefing/design meeting
Design	Pipe layout Pipe dimensioning Drawings Documentation
Prefabrication	Pipe bending Pipe end processing Pipe cleaning
Delivery	Assembly/ Dispatch Documentation
Assembly	On-site advice On-site assembly Testing and flushing Documentation



Pipe bending

Complete Piping Solutions

The complete solution for hydraulic systems

The Parker Complete Piping Solutions concept can be used in the most varied and demanding applications. These include shipbuilding, the oil industry, steel plants and other industrial applications. Parker piping solutions offer you the competent complete solution for hydraulic systems.

Starting with the design via pre-configuring to delivery and installation,



everything produced by Parker is top quality and extremely reliable. Even at an early stage of designing machines and systems, Parker engineers and technicians are available

to you to provide ideal assistance for the development of hydraulic line systems.

The support offered to you by Parker includes a suggestion for the type of connection (product to be used) and the choice of materials to be deployed starting with the lines and even the seals. The manufacture of special components, e.g. blocks or manifolds, is no problem for Parker.

If you have no opportunity for line configuration and assembly Parker is there and able to provide advice with its Complete Piping Solutions concept. It is completely irrelevant whether this is an initial fitting or modernising a machine or equipment. Parker's service covers measuring, preparing the pipeline flange connections, including the pipe flanges and assembling the connections.

Such customised mechanical hydraulic connections offer massive time savings during conversion, expansion or disassembly.



Machine preparation for the bending process



Delivery of components in secure packaging

ENGINEERING YOUR SUCCESS.

Our customer solutions

Achieving more together

Parker is highly successful with its weld-free piping systems for many applications.



In the Offshoremarket these are pipes for such different ship types as suction dredgers, work ships to install and supply oil platforms, ferries and installation ships for the wind industry. The most varied of hydraulic systems can be given Parflange F37 connections. Piping solutions are also created for drilling and transport towers, crane systems and hoists using Parker's weld-free systems.

It is always about fast, low-cost completion and installation. Weld-free systems enable customers to respond quickly and efficiently to new projects and generate new business. The hydraulic systems in plant and mechanical engineering are also equipped with the Parflange® F37 system. These are the hydraulic, cooling system and return lines.

Customers often have to fight against long manufacturing lead times for a new machine.

If for instance a main ring line for a cooling system needs to be welded, time passes before the final installation on the machine can take place. This is the result of such matters as the set-up and cleaning times for the pipe.

Other power piping applications include renewable energy industries (wind power, water power). Also vehicle construction (car, truck test stands) and general mechanical engineering (wood processing machines, press construction, waste processing).

Precision and flexibility are essential for all applications. Orientable flanges give the pipe fitter greater flexibility during assembly.

The Parflange® F37 machine (WCM-WorkCentre Model) offered by Parker gives the customer a high level of flexibility for on-site assembly.

In summary, the weld-free connection systems from Parker achieve a high level of financial and time savings, flexibility, precision, quality and reliability. And this is associated with extraordinary customer and delivery service.



Centrally located at the heart of Europe

Complete Piping Solutions Centre in Augustdorf



As a result of the global piping strategy introduced by Parker Hannifin some time ago, there is now also a German piping centre close to Bielefeld (in Augustdorf). The German CPS (Complete Piping Solutions) has a strategic location close to the Parker factory at Bielefeld-Windelsbleiche and the European Distribution Center (EDC). The CPS Germany offers comprehensive options for customer-specific piping system solutions. Piping

system solutions are developed in line with customer requirements and requests, in the newly designed office areas with modern IT equipment. The complete production process is characterised by optimised routes for materials ordering, manufacturing and then dispatch. The flow of goods has been copied from the existing piping centres and the associated positive experience gained.



Locations of the global Parker Piping Solutions Centres



The functional workshop can process pipes with external diameters up to 220 mm on the modern CNC bending machines. These machines can also realise 2xD to 3XD bending radii which are defined as standard for the relevant pipe diameters. The other machines also match the high quality standard used by Parker.

ENGINEERING YOUR SUCCESS.

The requirements increase

So does our performance

In order to comply with the market and customer requirements in this segment we have aligned our performance to this. The following overview aims to emphasise the range of services offered by CPS Germany.

Development and design:

- Modern CAD systems can process all common 3D and 2D data formats and simulate installation situations
- The projects are produced as required by or in cooperation with the customer. These may be new systems or upgrades
- It may require taking pipe measurements on-site using a modern measurement system. These data can be handed over to the CAD System
- Data from the measurement system are used later for quality control in order to ensure an ideal and secure production process

Cold bending:

- After creating the data required for production these are transferred to the machines. The available bending machines process tubes with diameters from 6 x 1 mm to 190 x 20 mm (thin-walled \varnothing 220 x 6 mm)

Tube end processing:

- Modern CNC controlled machines are available for processing pipe ends. Tube end processing is carried out based on internal standards

Tube cleaning:

- Tube cleaning using the ISO 4406 / NAS 1638 standard
- Permanent control of the pollution and cleanliness level with modern measuring devices

Pressure test:

- Pressure test to customer specifications possible
- Documentation at the customer's request



Installation / support:

- Delivery of pre-configured tube systems to the customer's desired address
- Installation of tube systems whilst taking into account the parameters and work steps set in the installation manual
- Installation by end customer training conducted by Parker



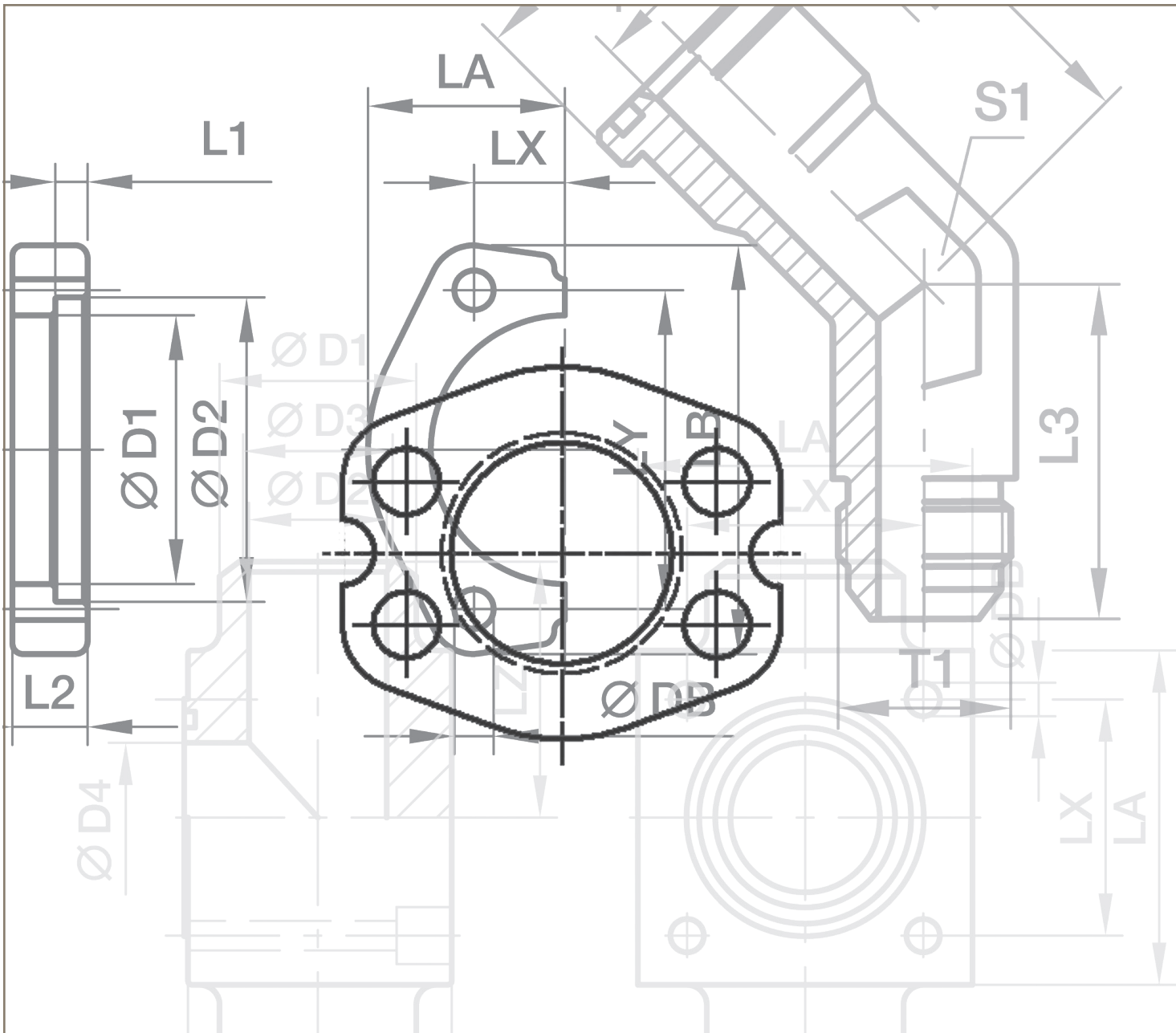

Technical data

Flange connection selection guide

To ensure the correct component selection for each application the following needs to be checked:



- Maximum operating pressure (pressure peaks to be considered)
(Check design pressure for the components involved in the connection.)
- Component material selection
Component material (steel, stainless steel, duplex, ...) suitable to corrosivity of medium and environment.
In case of mixed materials, the electrochemical difference and its resulting corrosion potential needs to be considered. In some cases, it is advisable to exclude the environmental influence (e.g., by using "denso tape").
- Medium compatibility
Check fluid compatibility chart on page 20.
- Medium and environment temperature
Calculate the allowable component working pressure in dependency of the medium and environment temperature according to pressure reduction table below.

Pressure reductions and temperatures for flanges and connection components

Required pressure reductions (depending on the material) with reference to the catalogue pressures for higher temperatures. Both metal fitting material and elastomeric sealing compound have to be selected according to the temperature range of the system.

DNV may require different pressure reduction based on application

Material	Pressure reduction of permissible operating temperatures TB in °C															
	-60	-54	-40	-35	-25	+20	+50	+100	+120	+150	+175	+200	+250	+300	+400	
Steel components			-10%			0%					-11%	-19%				
Steel, tubes			-10%			0%					-19%		-27%			
Stainless steel components	0%						-5%	-15%	-23%		-29%		-33%	-37%	-42%	
Stainless steel, tubes	0%						-5.5%	-11.5%	-21.5%			-29%		-34%		
Sealing material NBR (e.g. Perbunan)																
Sealing material FKM																
Sealing material Polyurethan (P5008)																

-  Permitted operating temperature
-  Permitted ambient temperature of hydraulic and pneumatic applications
-  Temperature not permitted

Calculation example:
 Temperature = 200°C
 Material = Stainless steel
 Pressure reduction = 29%
 Pressure reduction tubes = 21.5%
 PN tube 16x2.5/71. DIN2413 III = 362 bar

Formula:

$$PN_{200^{\circ}\text{C}} = \frac{400 \text{ bar}}{100\%} \times (100\% - 29\%) = 284 \text{ bar}$$

$$PN_{\text{tube } 200^{\circ}\text{C}} = \frac{362 \text{ bar}}{100\%} \times (100\% - 21.5\%) = 284 \text{ bar}$$

F37 seal

The F37 seal was developed especially for use with SAE flanges. Compared to a standard O-Ring the special profile of the F37 seal is ideally adapted to higher pressures and flange surface finish.

The particularly low compression set of the polyurethane compound (e.g. P5008) ensures dimensional stability of the seal over a large temperature range. Its high extrusion resistance prevents gap extrusion even if the flanges "breathe" under

pressure. Due to good abrasion resistance, less preparation is necessary on the surface finish of the sealing area of the flange. The frequently occurring "pumping" phenomenon of O-Rings is prevented by the shape of the F37 seal.

Application area

Sealing for SAE-Flanges

Working pressure: ≤ 600 bar

Working temperature: see table above

Materials

The F37 seal is made of a special polyurethane compound with a hardness of approx. 93 Shore A. In comparison with other polyurethane materials currently available on the market, it excels because of its increased heat resistance, improved performance against hydrolysis and low compression values.

For special requirements (pressure, temperature, flow speed, application in water, HFA-, HFB-fluids etc.), please contact our Consultancy Service, so that suitable materials and/or designs can be recommended.

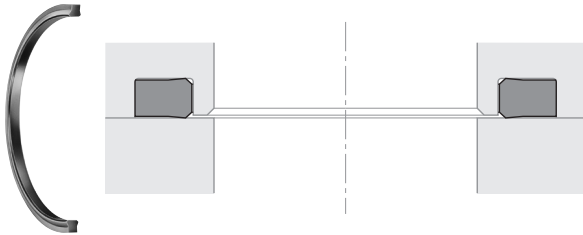

Material designation

Components	Flanges	Seal Carrier, Inserts	Thread adapters	Weld adapter	Soft seal
Material	- Carbon steel, zinc plated Cr(VI)-free, Zinc-Nickel plated or galvanized hot dip zinc - Stainless steel	- Carbon steel, zinc plated Cr(VI)-free or Zinc-Nickel - Stainless steel	- Carbon steel, zinc plated Cr(VI)-free - Stainless steel	- Carbon steel - Stainless steel	- NBR - FKM - PUR

Specification carbon steel for flange components/adapters:

forged or hot rolled steel

C22.3 / C22.8 / ASTM A 105 / S355J2 / C45 and equivalent or higher quality

Specification stainless steel for flange components/adapters:

forged or hot rolled stainless steel

AISI 316 / 316L or 316TI and equivalent or higher quality

1.4462 (S31803, S32205) and equivalent or higher quality

Specification carbon steel for pipes:

cold drawn seamless hydraulic tubes and pipes

E235 / E355 and equivalent or higher quality

Specification stainless steel for pipes:

cold drawn seamless hydraulic tubes and pipes

AISI 316 / 316L or 316TI and equivalent or higher quality

1.4462 (S31803, S32205) and equivalent or higher quality

Technical data

Fluid compatibility

Both metal fitting material and elastomeric seal compound have to be selected according to the fluid used. Standard recommendations for static seals based on experience and sealing compound manufacturers specification. For use of sealing compounds that are used for dynamic seals like rotary fittings or non-return valves, see note at end of table.

Fluid	Fitting material			Sealing material			
	Steel	Stainless steel	Brass	NBR	FKM	EPDM	P5008
Acetone	2	1	1	3	3	1	3
Acetylene	2	1	3	3	3	2	2
Air (oil free)	1	1	1	1	1	1	1
Ammonia liquid	2	1	3	2	3	1	3
Ammonia gas, cold	1	1	3	1	3	1	3
Animal oils (Lard oil)	2	2	2	1	1	2	3
Aral, Vitam BAF	1	1	X	1	1	3	2
Argon	1	1	1	1	1	1	1
Asphalt	3	1	3	2	1	3	2
ASTM-Oil, no. 1	1	1	1	1	1	3	2
ASTM-Oil, no. 2	1	1	1	1	1	3	2
ASTM-Oil, no. 3	1	1	1	1	1	3	2
ASTM-Oil, no. 4	1	1	1	2	1	3	x
ATF oil	1	1	1	1	1	3	1
Automotive brake fluid	1	1	1	3	3	1	2
Benzene	1	1	1	3	1	3	3
Brine (sodium chloride)	X	2	X	1	1	1	3
Butane	1	1	3	1	1	3	2
Carbon bisulphide	1	1	3	3	1	X	3
Carbon dioxide	1	1	1	1	2	1	3
Carbon oxide	1	1	1	1	1	1	1
Castrol, Biotec HVX	1	1	X	1	1	3	3
Chlorine (dry)	3	1	3	3	1	X	x
Compressed air	1	1	1	1	1	1	1
Crude oil	2	1	3	2	1	3	2
Cutting oil	1	1	X	1	3	1	x
DEA, Econa E22	1	1	X	1	X	3	x
DEA, ECONA E46	1	1	X	1	X	3	2
Diesel fuel	1	1	1	1	1	3	2
ECOOL	1	1	X	1	1	X	x
ESSO, Univis 13	1	1	X	1	1	3	x
ESSO, Univis 26	1	1	X	1	1	3	x
ESSO, Univis 32	1	1	X	1	1	3	x
ESSO, Univis 46	1	1	X	1	1	3	x
Ethanol (Ethylalcohol)	1	1	1	1	3	1	3
Ether	1	1	1	3	3	2	x
FINA, Biohydran RS 38	1	1	X	1	1	3	x
Flue gas	3	1	3	3	2	X	x
FRAGOL, Hydrolub 125	1	1	X	1	X	3	x
Freon 11	X	X	1	2	2	3	3
Freon 12	1	3	1	2	1	3	3
Freon 22	3	1	1	3	2	3	3
Gasoline	2	1	1	2	1	3	2
Gas, liquid propane	1	1	1	1	1	3	2
Glycerine	2	1	2	1	1	1	3
Glycol (Ethylenglykol)	1	1	2	1	1	1	3
Heating fuel oil	1	1	1	1	1	3	1
Helium	1	1	1	1	1	1	1
Houghton Safe 1120	1	1	X	3	1	1	3
Houghton Safe 620	1	1	X	1	2	1	3
Hydrochlorid acid	3	2	3	3	1	2	3
Hydrogen	3	1	X	1	1	1	1



Continued on page 23

Fluid compatibility

Fluid	Fitting material			Sealing material			
	Steel	Stainless steel	Brass	NBR	FKM	EPDM	P5008
Hydrogen peroxide	3	1	3	3	1	2	3
Hydrolube	1	1	1	1	1	1	x
Iodine	3	1	3	2	1	2	x
Kerosene	1	1	1	1	1	3	2
Lubricating oil SAE 10, 20, 30, 40 50	1	1	1	1	1	3	1
Methane	1	1	1	1	1	3	3
Methanol	1	1	1	1	3	1	3
MIL-F-8192 (JP-9)	1	1	1	3	1	3	x
MIL-H-5606	1	1	1	1	1	3	x
MIL-H-6083	1	1	1	1	1	3	x
MIL-H-7083	1	1	1	1	2	1	x
MIL-H-8446 (MLO-8515)	1	1	2	2	1	3	x
MIL-L-2104 & 2104B	1	1	1	1	1	3	x
MIL-L-7808	2	1	3	2	1	3	x
Mineral oil	1	1	1	1	1	3	1
Natural gas	1	1	2	1	1	3	2
Natural gas, untreated	3	2 ¹⁾	3	3	3	3	2
Natural mineral oil	1	1	3	2	1	3	1
Neon	3	1	1	1	1	1	1
Nitric acid	3	1	3	3	2	3	3
Nitrogen	1	1	1	1	1	1	1
Oil	1	1	3	1	1	3	2
Oxygen (gas, cold)	3	1	2	3	3	3	1
Ozone	1	1	3	3	1	1	1
Petrolatum	1	1	1	1	1	3	2
Petrolatum oil	1	1	1	1	1	3	3
Phosphoric acid	3	3	1	3	1	2	3
Plantohyd 32 S	1	1	X	1	1	3	x
Plantohyd 40 N	1	1	X	1	1	3	x
Propane	1	1	1	1	1	3	2
R134A	1	1	1	3	3	1	3
Sea Water	3	2	3	1	1	1	2
SHELL, Naturelle HF-E-46	1	1	X	1	1	3	2
SHELL, Tellus Oil DO 32	1	1	X	1	1	3	2
Silicone oil	1	1	X	1	1	1	1
Skydrol 500	1	1	3	3	3	1	3
Skydrol 7000	1	1	3	3	2	1	3
Soap solutions	3	1	3	1	1	1	2
Steam	2	1	2	3	3	1	3
Stoddard solvent	1	1	2	1	1	3	1
Sulphur dioxide	3	1	3	3	3	1	3
Sulphuric acid	3	2	3	3	1	3	3
Toluol	1	1	1	3	2	3	3
Transmission fluid	1	1	1	1	1	3	2
Trichlorethane	2	1	X	3	1	3	3
Turpentine	2	1	3	1	1	3	3
Water	2	1	1 ²⁾	1	2	1	2
Xylol	1	1	1	3	1	3	3

up to 60°C

up to 60°C

Applicability:

1 = satisfactory

2 = fair

3 = not recommended

X = insufficient data

NBR = e.g. Perbunan (registered trademark of Bayer)

FKM

¹⁾ Untreated natural gas requires stainless steel with reduced material hardness.

²⁾ Brass is resistant against crack under normal circumstances. If overloaded (e.g. by overassembly) the resistance especially against ammoniac and nitric derivatives can be negatively influenced. This might cause the defect of the connection.

This fluid compatibility chart is only applicable on so called "static seals", such as O-rings and profile sealing rings (e.g. ED-seal, DOZ-seal) in tube fitting and flange systems.

For fluid compatibility data of valves, rotary fittings or other multi-function components please review the relevant product pages.

ENGINEERING YOUR SUCCESS.

Pressure reductions and temperatures for ball valves

Body, adapters, stem and ball materials	Pressure reduction of permissible operating temperatures TB in °C													
	-60	-50	-40	-30	-20	-10	0	+20	+80	+100	+120	+130	+150	+200
Free-Cutting steel, not suitable for gas applications!	0%													
Low-Alloy Steel	-25%					0%								
Stainless steel	0%										-11%			
Duplex Steel						0%					-20%			

Ball seat material	Pressure reduction of permissible operating temperatures TB in °C													
	-60	-50	-40	-30	-20	-10	0	+20	+80	+100	+120	+130	+150	+200
POM	0%													
Cast Iron GG25	0%													

Stem and adapter sealing materials	Pressure reduction of permissible operating temperatures TB in °C													
	-60	-50	-40	-30	-20	-10	0	+20	+80	+100	+120	+130	+150	+200
Acrylonitrile-butadienerubber (NBR, Buna N)				0%										
Low-temp NBR Compound	0%													
FKM					0%									
Low-temp FKM Compound			0%											
EPDM			0%											

	Permitted operating temperature
	Temperature not permitted

A test pressure of 1.5 x PN applies to all ball valves in accordance with DIN 3230 T5 and ISO 5108 for body.

1.1 x PN applies to ball seats.

The nominal pressure specifies the admissible working pressure at 20°C. Please consider the pressure reduction at higher temperature.

The safety factor for burst pressure tests is a minimum of 2.4 times the nominal pressure.

$P_{Burst} = 2.4 \times PN$

Leakage tests are done acc. DIN EN 12266 leakage rate A (No visually noticeable leakage during the duration of the test with fluid or air).

For other materials than listed, please contact Parker HPCE.





Installation F37 Flange system

Current installation guide:

www.parker.com/hpce ↴

Resources ↴

Installation Guides & Manuals

ENGINEERING YOUR SUCCESS.

Notes

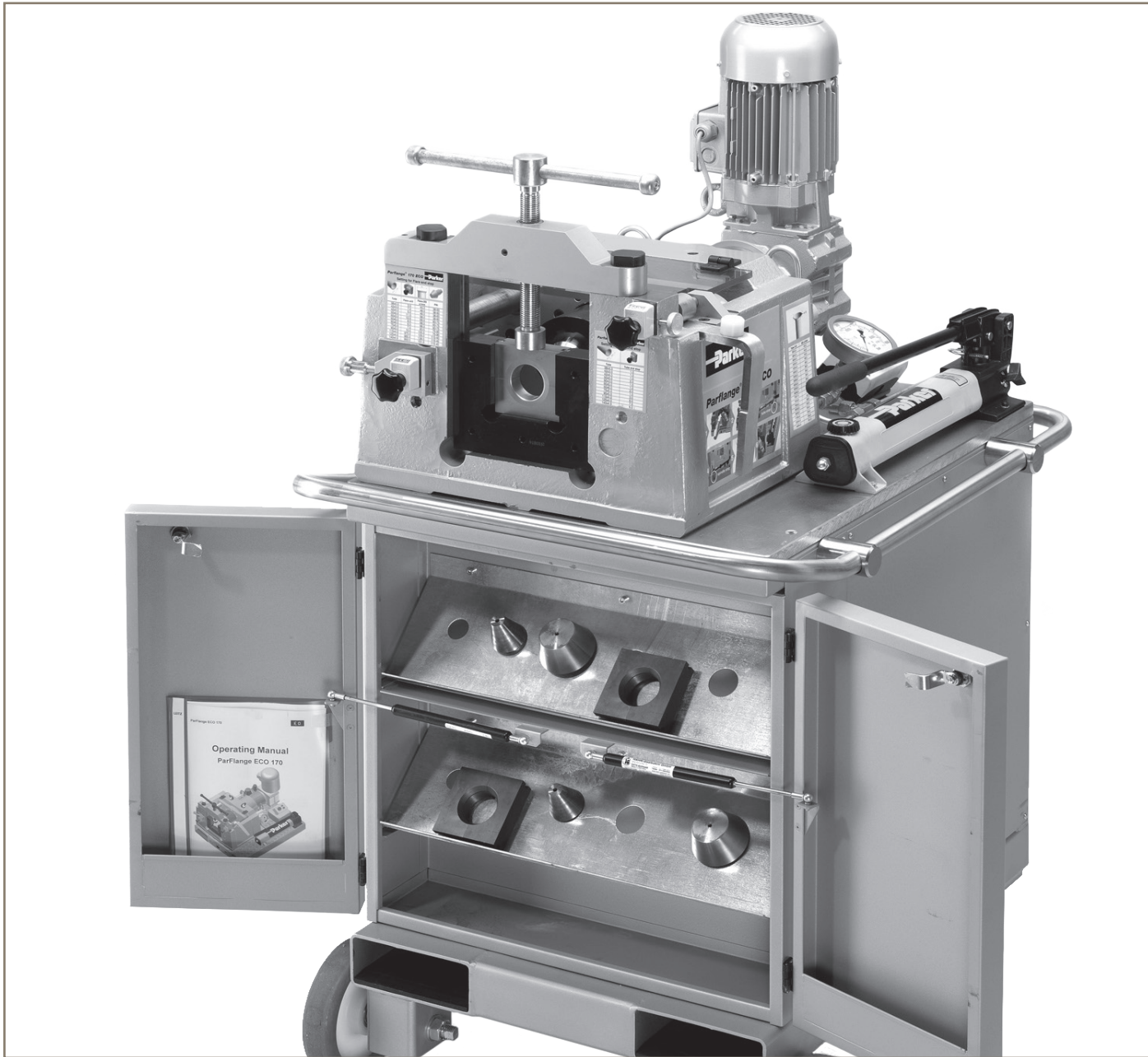

Machines, tooling and equipment

ENGINEERING YOUR SUCCESS.

Parflange® 170

Workshop machine for F37 flange connections

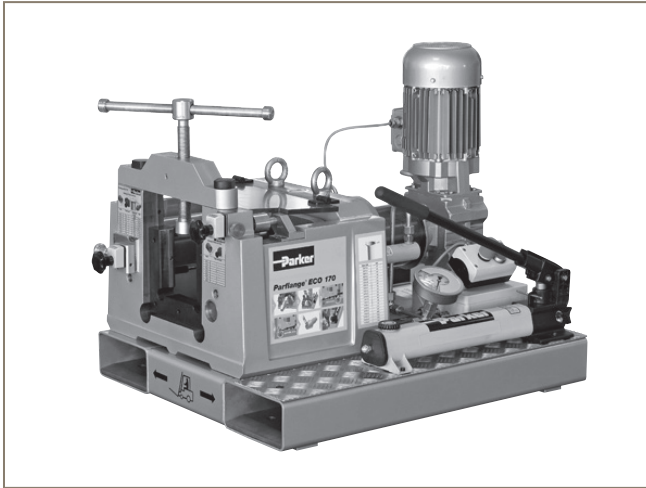

Parflange® 170 ECO for workbench

The Parflange® 170 ECO is a compact workshop machine for 37° flaring of tubes for flange connections.

The orbital tube flaring is achieved by a rotating flaring unit, powered by an electro-mechanical drive. Two hydraulic cylinders operated by a hand pump generate the axial feed movement. Gas springs move the flaring unit back after the valve on the hand pump is opened. The tubes are mechanically clamped between a set of dies. The machine features an adjustable tube stop for tube positioning (Tube Stop), and an adjustable stop for the tube depth to be flared (Spindle Stop).

The machine is used to form tube ends by means of a rotational action. It is designed as a workshop machine for installations of tube connections.

The machine is available in 2 versions:

- Parflange® 170 ECO for use on work bench and
- WorkCenter Parflange® 170 WCM which is mounted on a movable tool cabinet

Parflange® machines are delivered ready for use. Tools have to be ordered separately. Clamping die sets and flanging pins are available for common tube sizes. The machine can be moved by crane or forklift.

Applications

- The F37 system is an alternative to conventional welding of flanges in shipbuilding, oil & gas exploration and similar industries
- Workshop use, project work, plant maintenance, on-site assembly
- Not recommended for mass production



Parflange® 170 WCM WorkCenter

Specifications

Purpose	37° flaring for Parker F37 flange connection
Process	Tube forming by orbital flaring process
Design	On-site and workshop machine for individual tube manufacturing
Models	<ul style="list-style-type: none"> ● Parflange® 170 ECO for use on work bench, easy to transport, optimal to use on site ● WorkCenter Parflange® 170 WCM, mounted on a movable tool cabinet, optimal to use in a production hall
Operation	Manual tube clamping Electrically driven flaring unit Manual feed by hand-pump
Tube diameter	16 mm – 168.3 mm O.D.
Maximum capacity	168.3 x 2.77 mm
Tube material	Steel and stainless steel
Cycle time	1 – 2 minutes flaring time 3 – 5 minutes total cycle time
Economic production quantity	Up to 50 assemblies per day
Tools	Flanging pin BF37... Clamping die set MF37... Die frames required for small to medium sizes
Tool lubrication	manual
Forming lubricant for pin	LUBSS
Machine dimensions (L x W x H)	Parflange® 170 ECO: 850 x 680 x 675 mm Parflange® 170 WCM: 880 x 810 x 1470 mm
Weight	Parflange® 170 ECO: approx. 350 kg Parflange® 170 WCM: approx. 460 kg
Nominal voltage	400 V/3Ph/50 Hz/3A/1.1 KW
Connecting cable	3m/CEE 16A
Sound pressure level	Less than 70 dB (A)

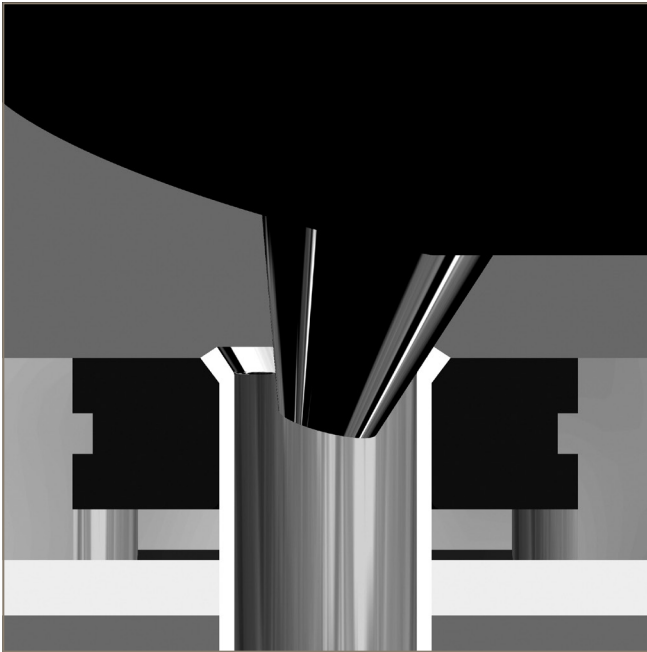

Superior sealing surface is achieved by orbital flaring

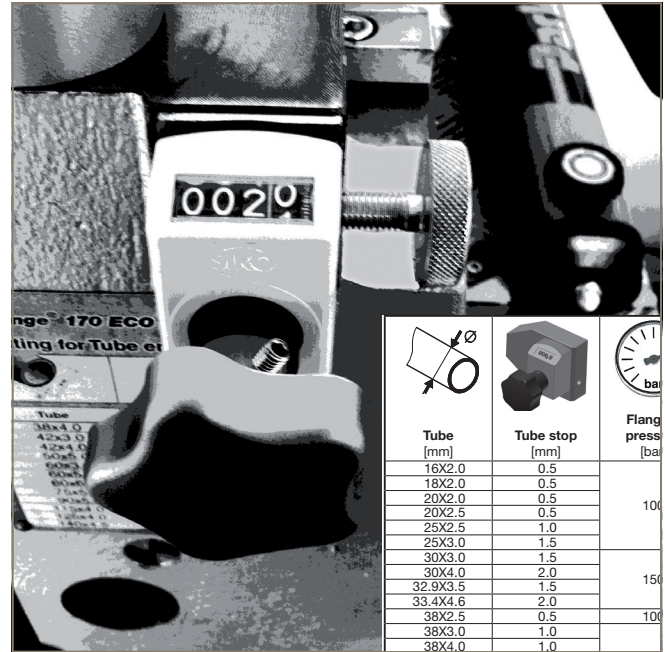

Consistent flaring result is achieved by setting of Tube Stop and Spindle Stop

Features, advantages and benefits of Parflange® 170 ECO

- Cost saving** – Compared to welding or brazing, orbital flaring is much less time consuming. Special tube preparation and finishing are not necessary. Flaring uses only a fraction of the energy needed for brazing or welding.
- Zinc plated tubing** – The Parflange® process allows the use of zinc plated tubing. The cost for cleaning, post process plating or painting is saved.
- Superior sealing performance** – The orbital flaring process achieves a sealing surface of superior surface quality and mechanical strength.
- Process/Product concept** – Parflange® machines are especially designed to match Parker F37 flange standards. Machines, tools and products are fine-tuned for reliable performance.
- Workshop use** – The rigid machine design allows project work in on site piping workshops.
- Short clamping length** – Clamping dies for 37° flaring are optimized for minimum straight tube length.
- Easy to use** – All operational devices are obvious so that machine operation is intuitive.
- Quality** – Consistent quality results are achieved by recommended values for machine setting.
- Constant flare diameter** – The diameter of the 37° flare is given by the tool contour and the Tube Stop adjustment. A chart on the machine indicates recommended Tube Stop setting.
- Prevention of over-flaring** – The shape of the 37° flare is given by the tool contour and the Spindle Stop adjustment. This prevents difficulties to fit the insert into the flare.
- Flexible** – Different tube material and quality might require special setting of Tube Stop, Spindle Stop, flanging feed and flanging force. For best results, these parameters can be manually adjusted based on operators experience.
- Clean** – The Parflange® process is environmentally clean and safe. As no heat or chemicals are used, hazards from fumes or heat do not occur.
- Perfect for on site work** – The machine has special attachments for transportation by fork lift and crane. The wide base provides a safe stand. This is particularly useful for on site pipe installation in shipyards or in oil and gas exploration.
- Ready to go** – The Parflange® 170 ECO is delivered including all necessary details like electrical plug, operator manual, declaration of CE-conformity, short instruction pictograms on machine housing and dimensional charts for tube preparation.
- Parflange® 170 WCM** – This model is mounted on a robust tool cabinet with wheels. It is easy to move and perfect for flexible workshop use.

ENGINEERING YOUR SUCCESS.

Tool selection

Workshop machine for F37 flange connections

Ordering

Type	Order code
Parflange® 170 Basic machine	
Ready to use, including operation manual, filled with hydraulic oil, without tools	
Basic machine for workbench use, 400V, 50Hz	170EU400VECO
WorkCenter with tool cabinet, 400V, 50Hz	170EU400VWCM
Promotion leaflet 4162/UK	via Parker catalogue service EMDC
Tool lubricant qty: 1 L	LUBSS

Parflange® machines are shipped in special containers which should be kept for future transportation to avoid damage.

Clamping die frame small/large		Clamping die set "MF"	Extended clamping die set "MF" for large tube wall thickness	Flanging pin "BF"
Tube O.D. mm	Order code Clamping die frame	Order code Clamping die set	Order code Extended clamping die set	Order code Flanging pin
16.0	MF37/FRAME20-60	MF37-16		BF37-6/42
20.0		MF37-20		
25.0		MF37-25		
26.7		MF37-26.7		
30.0		MF37-30		
32.9		MF37-32.9		
33.4		MF37-33.4		
38.0		MF37-38		BF37-38/60
42.0		MF37-42		
48.3		MF37-48.3		
50.0		MF37-50		BF37-60/75
60.0		MF37-60		
60.3		MF37-60.3		
65.0		MF37/FRAME73-90		MF37-65 E
73.0	MF37-73		MF37-73E for Tube 73X7	
75.0	MF37-75			
88.9	MF37-88.9			
90.0	MF37-90			
90.9			MF37-90E	BF37-90PREFLARE and BF37-75/90
100.0	no frame required	MF37-100		BF37-100
114.3		MF37-114.3	MF37-114.3E for Tube 114.3X6.02	BF37-115/140
115.0		MF37-115		
125.0		MF37-125		
139.7		MF37-139.7		
140.0		MF37-140		BF37-141/165
141.3		MF37-141.3		
165.0		MF37-165		
168.3		MF37-168.3		

tools for scheduled pipes on request

Tool lifetime

Assembly tools are subject of wear and must be regularly cleaned and checked.

Worn out tools can cause dangerous assembly failures and must be replaced in time.

Maximum lifetime can be achieved by following factors:

- Regular cleaning and checking
- Clean and corrosion-protected storage
- Proper de-burring and cleaning of tube end
- Proper tool selection and operation
- Use of specified lubricant



Assembly machines

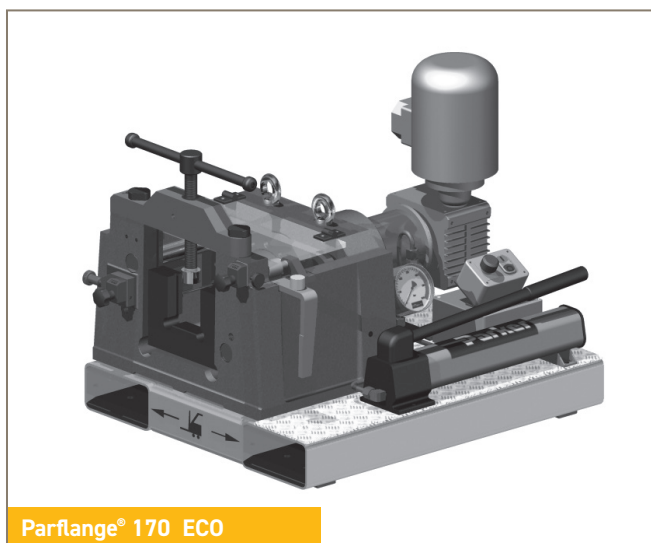

Parflange® 170 ECO

Parflange® 170 ECO

The Parflange® 170 is a simple flaring machine for Parker F37 connections. By using the Parflange® process, it achieves an excellent sealing surface and a high-strength tube connection.

The equipment is very robust and easy to use. It saves time and effort compared to conventional welding of flange connections.

Parflange® 170 WCM Workcenter is ideal for workshop use. The 170 ECO is ideal for onsite installation.

- 37° flaring of: F37 flange connection
- Tube-OD: 16 - 168.3 mm
- Total cycle time: 30 - 60 sec.
- Economic production quantity: max. 50 assemblies per day
- Dimensions (L x W x H): ECO: 850 x 680 x 675
- Weight: 360 kg
- Power supply: 400 V 3-phase 50 Hz 1,1 kW

Catalogue: 4100



Parflange® 170 WCM

Parflange® 170 WCM

The Parflange® 170 WCM is a flaring Work Centre for Parker F37 connections. By using the Parflange process, it achieves an excellent sealing surface and a high-strength tube connection.

The machine is mounted on a robust tool cabinet with wheels. The EO2-FORM F3 represents a complete tube forming WorkCenter.

The Parflange 170 WCM is ideal for workshop use and on-site installation.

- 37° flaring of: F37 flange connection
- Assembly method: Orbital forming
- Tube-OD: 16 - 168.3 mm
- Total cycle time: 30 - 60 sec.
- Economic production quantity: max. 150 assemblies per day
- Dimensions (L x W x H): 880 x 810 x 1470

- Weight: 460 kg
- Power supply: 400 V 3-phase 50 Hz

Catalogue: 4162

Bulletin: 4165

Lubricants

EO-NIROMONT lubricant for fitting assembly

EO-NIROMONT lubricant for flaring and forming tools

EO-NIROMONT are high performance lubricants specifically designed for the assembly of tube connections. They facilitate tightening using a low-torque when assembling joints by hand. In machine assembly, the use of EO-NIROMONT ensures that maximum tool-life is achieved. In forming processes, such as Parflange® or EO2-FORM, smooth and error-free sealing surfaces can be produced. Special additives prevent cold welding when working with stainless steel.

As opposed to when using Parker high performance lubricants, experience shows that the use of standard commercially available lubricants tend to lead to problems such as cold welding of forming tools, particularly when processing stainless steel tube. Parker high performance lubricants – EO-NIROMONT – are offered in different containers and viscosities so that you can purchase the appropriate product in a suitable container to meet your needs:

Liquid lubricant, plastic bottle (item: EONIROMONTFLUOSSX)

Parker high performance lubricant for the lubrication of threads, progressive rings and for all cold forming processes like Parflange® or EO2-FORM. The handy plastic bottle means that it can be applied directly where the lubrication is needed. EO-NIROMONT liquid should always be available at every assembly point where hydraulic connections are being made.

Liquid lubricant, refill package (Item: LUBSS)

Parker high performance lubricant for all cold forming processes like Parflange® or EO2-FORM. Its viscosity means that it is for use in automatic lubrication devices installed in Parflange machines. Absolutely essential for mechanical cold forming of stainless steel tubes.

Paste lubricant, tin (Item: EONIROMONTPASTX)

Parker high performance lubricant for the lubrication of the threads of the pre-assembly tool VOMO. The paste is economical and provides durable thread lubrication. Not suited for use with forming tools, as dust and swarf will stick to it.

Liquid lubricant in a brush-in-cap can (item: EONIROMONTAPPLICATOR)

Thanks to a brush built into the screw cap, the practical EO-NIROMONT APPLICATOR enables the Parker high-performance lubricant to be applied accurately on the component. The plastic bottle can be used to refill the brush-in-cap can practically.

Features, advantages and benefits of NIROMONT lubricant:

1. **Highly effective** – EO-NIROMONT dramatically reduces assembly effort. This helps to prevent fitting failure resulting from insufficient assembly.
2. **Cost saving** – Tools in assembly machines will last much longer, resulting in high-quality tube forming with excellent sealing surface.
3. **No cold welding** – Cold welding of stainless steel threads is impossible when EO-Niromont is properly applied.
4. **Liquid** – Penetrates even small gaps.
5. **Paste** – Stays in place for a while. Ideal for application on pre-assembly tools.
6. **Compatible** – EO-NIROMONT and LUBSS do not effect fitting surfaces or seal materials.

Ordering

Type	Order code
EO-NIROMONT Assembly lubricant paste (100 g e)	EONIROMONTPASTX
EO-NIROMONT Assembly lubricant liquid (250 cc)	EONIROMONTFLUOSSX
EO-NIROMONT Liquid lubricant in a brush-in-cap can (250 cc)	EONIROMONTAPPLICATOR
EO-NIROMONT Forming tool lubricant refill (1 L)	LUBSS



EO-NIROMONT



EO-NIROMONT APPLICATOR



LUBSS

Assembly machines

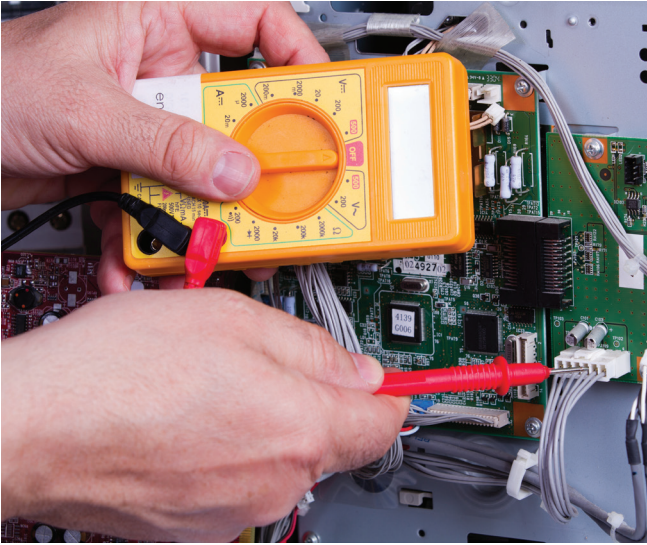

Technical support for Parker machines

HPCE machine service procedures ensure that reliable machine function and fitting performance is achieved when using genuine Parker assembly equipment.

All machines come with detailed operating manuals. Parker distributors and sales representatives are trained to give advice on operation and applications. Experienced application engineers at HPCE are available when it comes to special application of HPCE assembly equipment.

In case of machine malfunction, spare machines can be provided on short notice so that production can continue. In the meantime, damaged machinery is checked and repaired at the HPCE machine repair facility. Well trained and experienced engineers take personal care that the machines return properly repaired and tested.

HPCE also offers a machine maintenance and calibration service. Standard spare parts like oil filters can be ordered.

Notes

ISO 6162-1

F37 seal

on

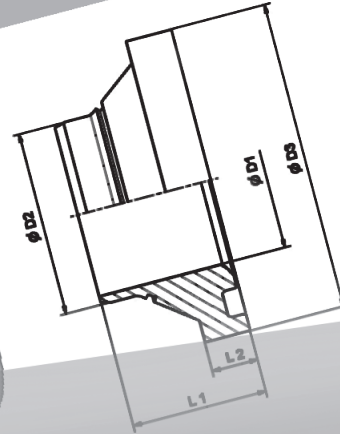

How to order

Selecting

1. All flange sizes are clearly listed in the catalogue.
2. Open the catalogue to find the detailed information of your choice.
3. Select the product based on the requirements.

D1	D2	D3	L1	L2	Weight (Steel) kg/1 piece	F37 seal Order code	O-Ring Order code	Insert incl. F37 seal + O-Ring Order code
25.0	32.8	45.0	22.0	7.0	0.11	F37S16X	OR34X1.0X	IN16-38X2.5TFVCF
25.0	31.8	45.0	22.0	7.0	0.10	F37S16X	OR34X1.0X	IN16-38X3.0TFVCF
25.0	29.8	45.0	22.0	7.0	0.10	F37S16X	OR30X1.0X	IN16-38X4.0TFVCF
25.0	27.8	45.0	21.0	7.0	0.09	F37S16X	OR28X1.0X	IN16-38X5.0TFVCF
29.5	31.8	50.0	22.0	7.5	0.10	F37S20X	OR34X1.0X	IN16-38X6.0TFVCF
27.0	29.8	50.0	22.0	7.5	0.11	F37S20X	OR30X1.0X	IN16-38X7.0TFVCF
25.5	27.8	50.0	21.0	7.5	0.10	F37S20X	OR28X1.0X	IN16-38X8.0TFVCF
31.5	35.8	50.0	22.0	7.5	0.11	F37S20X	OR37.8	IN16-38X9.0TFVCF
31.5	33.8	50.0	22.0	7.5	0.10	F37S20X	OR34	IN16-38X10.0TFVCF
29.5	29.8	50.0	21.0	7.5	0.10	F37S24X	OR37	IN16-38X11.0TFVCF
27.0	27.8	50.0	22.0	7.5	0.10	F37S24X	OR34	IN16-38X12.0TFVCF
25.5	35.8	50.0	22.0	7.5	0.10	F37S24X	OR44	IN16-38X13.0TFVCF
31.5	33.8	50.0	22.0	7.5	0.10	F37S24X	OR41	IN16-38X14.0TFVCF
31.5	35.8	60.0	25.5	10.0	0.19	F37S24X	OR41	IN16-38X15.0TFVCF
33.5	33.8	60.0	25.0	10.0	0.19	F37S24X	OR44	IN16-38X16.0TFVCF
31.5	43.8	60.0	25.5	10.0	0.20	F37S24X	OR41	IN16-38X17.0TFVCF
36.0	39.8	60.0	27.0	10.0	0.20	F37S24X	OR44	IN16-38X18.0TFVCF
36.0	37.8	60.0	27.0	10.0	0.22	F37S32X	OR41	IN16-38X19.0TFVCF
35.0	43.8	70.0	24.0	10.0	0.24	F37S32X	OR41	IN16-38X20.0TFVCF
41.5	39.8	70.0	26.5	10.0	0.27	F37S32X	OR41	IN16-38X21.0TFVCF
37.5	37.8	70.0	27.0	10.0	0.27	F37S32X	OR41	IN16-38X22.0TFVCF
37.5	37.8	70.0	27.0	10.0	0.24	F37S32X	OR41	IN16-38X23.0TFVCF
35.0	53.8	70.0	26.5	10.0	0.23	F37S40X	OR41	IN16-38X24.0TFVCF
35.0	53.8	70.0	26.5	10.0	3.50	F37S40X	OR41	IN16-38X25.0TFVCF



Ordering information/Nomenclature

Parflange® F37 Code Key

Flare Flange Example:

F37-3	20	-42X3.0	TFV	CF
--------------	-----------	----------------	------------	-----------

Part code		
Flange Type	Flange code	Footprint
F37	1	ISO 6162-1 SAE 1000
F37	3	ISO 6162-1 SAE 3000
F37	6	ISO 6162-2 SAE 6000
F37	4	ISO 6164

Size Code												
8	12	16	20	24	32	40	48	64	80	96	128	160
1/2"	3/4"	1"	1 1/4"	1 1/2"	2"	2 1/2"	3"	4"	5"	6"	8"	10"

Pipe size and Insert Code	
42X3.0	/ Pipe O. D. X wall thickness (mm)

Flange connection/Sealing system	
TFV	Tube to port connection, F37 seal version
TFB	Tube to port connection, Bonded seal version
TT	Tube to tube connection
TF	Tube to flange connection, Flat face version

Material and coating	
CF	Steel, Cr(VI)-free
CFTZN	Steel, Hot dip galvanized (only Flanges)
SS	Stainless Steel

Bolts and nuts are not components of the complete Part code

Combination examples

	Complete Part No.	Component	No.	Code	Material
Standard combination Steel CF	F37-320-42X3.0TFVCF Tube to port (F37 seal) 1 1/4" SAE 3000 Flare Flange	Flare Flange	1	F37-320-CFX	Steel, Cr(VI)-free
		Insert incl. O-Ring and F37 Seal	1	IN20-42X3.0TFVCF	Steel, Cr(VI)-free
		O-Ring	1	OR37.82X1.78X	NBR, 90° shore
		F37 Seal	1	F37S20X	PUR
Stainless Steel	F37-620-38X4.0TFVSS Tube to port (F37 seal) 1 1/4" SAE 6000 Flare Flange, 38 mm OD tube Jump size	Flare Flange	1	F37-620/38-SSX	Stainless Steel
		Insert incl. O-Ring and F37 seal	1	IN20-38X4.0TFVSS	Stainless Steel
		O-Ring	1	OR30X1.0X	NBR, 90° Shore
		F37 seal	1	F37S20X	PUR
Hot. dip galv. Flange and Stainless Steel Insert	F37-620-38X4.0TFVSSTZN Tube to port (F37 seal) 1 1/4" SAE 6000 Flare Flange, 38 mm OD tube Jump size	Flare Flange	1	F37-620/38-TZNX	Hot dip galv.
		Insert incl. O-Ring and F37 seal	1	IN20-38X4.0TFVSS	Stainless steel
		O-Ring	1	OR30X1.0X	NBR, 90° Shore
		F37 seal	1	F37S20X	PUR

Before ordering components please check requirements from the classification companies.



Parflange® Retaining Ring Code Key

Retaining Ring Examples:

R-1	32	WA	-60.3X2.9	S
------------	-----------	-----------	------------------	----------

Part code		
Flange Type	Flange code	Footprint
R	1	ISO 6162-1 SAE 1000
R	3	ISO 6162-1 SAE 3000
R	6	ISO 6162-2 SAE 6000
R	4	ISO 6164 4 Bolt Flange
R	8	8-12 Bolt Flange*

Size Code													
8	12	16	20	24	32	40	48	64	72	80	96	128	160
1/2"	3/4"	1"	1 1/4"	1 1/2"	2"	2 1/2"	3"	4"	4 1/2"	5"	6"	8"	10"

Weld adapter

Pipe size and Insert Code
60.3X2.9/Pipe O. D. X wall thickness (mm)

Material and coating	
S	Weld Adapter O-Ring Sealing by SAE 1000 (other footprints bonded seal), Steel
FS	Weld Adapter Flat, Steel
SS	Weld Adapter O-Ring sealing, Stainless Steel
FSS	Weld Adapter Flat, Stainless Steel
SSTZN	Weld Adapter O-Ring sealing, Stainless Steel and hot dip galv. Flange
FSSTZN	Weld Adapter Flat, Stainless Steel and hot dip galv. Flange

*Round flange design; Footprint deviating from ISO-/SAE-Standards
Bolts and nuts are not components of the complete Part code

Combination examples

	Complete Part No.	Component	No.	Code	Material
Standard combination Steel CF	R-132WA-60.3X2.9S SAE 1000 Retaining Ring Weld Adapter	Retaining Ring Flange	1	R-132-CFX	Steel, Cr(VI)-free
		Retaining Ring		R32X	Stainless Steel
		Weld Adapter body O-Ring	1	WA132-60.3X2.9S OR56.75X3.53X	Steel, Cr(VI)-free NBR, 90° Shore
Stainless Steel	R-620WA-38X4.0SS SAE 6000 Retaining Ring Weld Adapter	Retaining Ring Flange	1	R-620-SSX	Stainless Steel
		Retaining Ring	1	R20X	Stainless Steel
		Weld Adapter body	1	WA20-38X4.0SSX	Stainless Steel
		Bonded seal	1	BS20SSNX	Stainless Steel/ NBR, 90° Shore
Stainless Steel	R-PSC8128-250X25VSS SAE 6000 8" Retaining Ring and Pipe seal carrier, 250 mm OD tube	Retaining Ring Flange	1	R-8128-SSX	Stainless Steel
		Retaining Ring	1	R128X	Stainless Steel
		Pipe seal carrier	1	PSC128-250X25VSSX	Stainless Steel
		F37 seal	1	F37RS128X	PUR

Before ordering components please check requirements from the classification companies.

ENGINEERING YOUR SUCCESS.

Notes











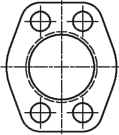

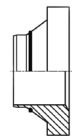
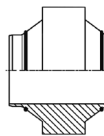
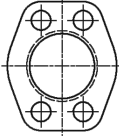

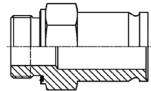
SAE 1000 System

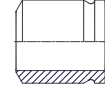
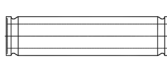
50 – 70 bar

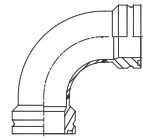
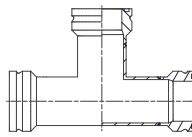
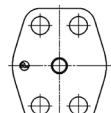
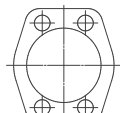
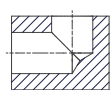
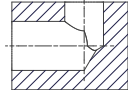
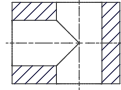
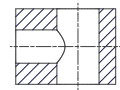
ENGINEERING YOUR SUCCESS.

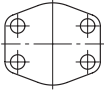
Programme overview SAE 1000/ISO 6162-1 footprint

Parflange® F37 connection parts	Flanges  F37 – p.39	
	Inserts    TFV – p.41 TF – p.42 TT – p.43	
Retaining ring connection parts	Flanges    R – p.40 R-Ring – p.44 R – p.40	
	Male / Female   MTF-R – p.45 FTF-R – p.46	Weld   WA – p.47 WA-F – p.48
	Tube to Tube     BF – p.49 RF – p.50 LF – p.51 TF – p.52	
	Blind Flanges   BFV – p.53 CPML – p.54	Blocks see SAE 3000     LB – p.85 LBR – p.86 TB – p.87 TBR – p.88
Seals Adapter Bolts	Bolts and Nuts  p.55	
	 AP – p.56	
Ball valves	 p. 57/58	

F37 – Flare flange | SAE 1000/ISO 6162-1 footprint

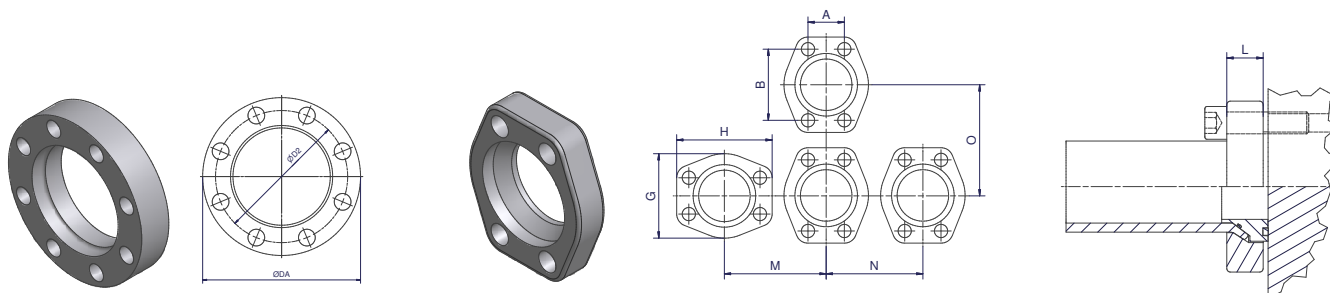

Parflange F37 flange dimensions

Size Inch	Flange Order Code	A	B	G	H	M	N	O	L	Bolts/pc.	Weight (Steel) kg/1 piece	W.P. bar
1 1/2	F37-124-CFX	35.7	69.9	83	94	93	87	99	20	4	0.52	70
2	F37-132-CFX	42.9	77.8	97	102	104	102	107	25	4	0.83	70
2 1/2	F37-140-CFX	50.8	88.9	109	114	117	114	120	30	4	1.16	70
3	F37-148-CFX	61.9	106.4	131	135	138	136	141	30	4	1.57	70
3 1/2	F37-156-CFX	69.9	120.7	140	152	151	145	158	30	4	1.99	70
4	F37-164-CFX	77.8	130.2	152	162	162	157	168	39	4	2.69	70
5	F37-180-CFX	92.1	152.4	181	184	188	186	190	39	4	3.24	50
		D2	DA									
6	F37-196-CFX	208.0	235.0						39	6	5.60	50
8	F37-1128-CFX	275.0	318.0						39	8	10.51	50
10	F37-1160-CFX	345.0	410.0						50	8	25.35	50

Pressure rates related to flanges. For all sizes also threaded flanges available (...T-CFX).

Please change suffixes according to material/surface required

Order code suffixes			
Material	Suffix surface and material	Example	Comments
Steel, zinc plated, Cr(VI)-free	CF	F37-124-CFX	
Stainless steel	SS	F37-124-SSX	
Galvanized hot dip zinc	TZN (Not for threaded flanges available)	F37-124-TZNX	on request

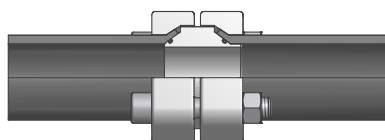

Part combination flaring SAE 1000

Flange Pressure (bar)	Size Inch	Pipe Size	Flange 1000 SAE ISO 6162-1 footprint	Insert*
70	1 1/2	50X3.0	F37-124-CFX	IN24-50X3.0T...
	2	60X3.0	F37-132-CFX	IN32-60X3.0T...
	2 1/2	75X3.0	F37-140-CFX	IN40-75X3.0T...
	3	88.9X3.05	F37-14888.9-CFX	IN48-88.9X3.05T...
	3	90X3.5	F37-148-CFX	IN48-90X3.5T...
	3 1/2	100X4.0	F37-156-CFX	IN56-100X4.0T...
50	4	115X4.0	F37-164-CFX	IN64-115X4.0T...
	5	140X4.5	F37-180-CFX	IN80-140X4.5T...
	6	165X5.0	F37-196-CFX	IN96-165X5.0T...
	8	220X6.0	F37-1128-CFX	IN128-220X6.0T...
	10	273X6.0	F37-1160-CFX	IN160-273X6.0T...

Select the complete version:

- * ...FVCF Seal version
- ...TCF Tube to Tube version
- ...FCF Flat Face version

Other sizes on request. Bolts and nuts are not included in complete part numbers. For recommended bolts and nuts see page 55.

R – Retaining ring flange | SAE 1000/ISO 6162-1 footprint

SAE 1000/ISO 6162-1 footprint

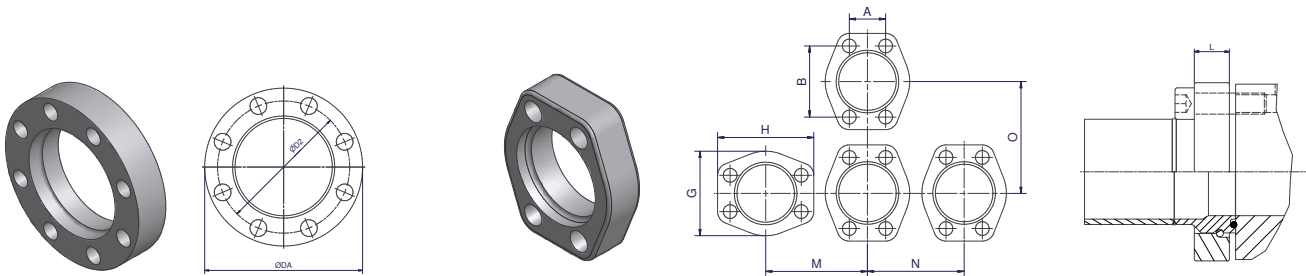

Retaining Ring Flange dimensions

Size Inch	Flange Order code	A	B	G	H	M	N	O	L	Bolts/pc.	Weight (Steel) kg/1 piece	W.P. bar
1 1/2	R-124-CFX	35.7	69.9	83	94	93	87	99	20	4	0.46	70
2	R-132-CFX	42.9	77.8	97	102	104	102	107	20	4	0.57	70
2 1/2	R-140-CFX	50.8	88.9	109	114	117	114	120	20	4	0.70	70
3	R-148-CFX	61.9	106.4	131	135	138	136	141	25	4	1.18	70
3 1/2	R-156-CFX	69.9	120.7	140	152	151	145	158	29	4	1.47	70
4	R-164-CFX	77.8	130.2	152	162	162	157	168	30	4	1.74	70
5	R-180-CFX	92.1	152.4	181	184	188	186	190	39	4	2.81	70
		D2	DA									
6	R-196-CFX	208.0	235.0						39	6	4.96	70
8	R-1128-CFX	275.0	318.0						38	8	8.95	50
10	R-1160-CFX	345.0	410.0						50	8	23.29	50

Pressure rates related to flanges. For all sizes also threaded flanges available (...T-CFX).

Please change suffixes according to material/surface required

Order code suffixes		
Material	Suffix surface and material	Example
Steel, zinc plated, Cr(VI)-free	CF	R-124-CFX
Stainless steel	SS	R-124-SSX
Galvanized hot dip zinc	TZN (Not for threaded flanges available)	R-124-TZN

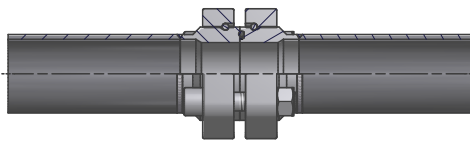

Part combination retaining ring SAE 1000 (O-Ring) connection

Flange pressure (bar)	Size Inch	Flange	Retaining Ring
70	1 1/2	R-124-CFX	R124X
	2	R-132-CFX	R132X
	2 1/2	R-140-CFX	R140X
	3	R-148-CFX	R148X
	3 1/2	R-156-CFX	R156X
	4	R-164-CFX	R164X
	5	R-180-CFX	R180X
50	6	R-196-CFX	R196X
	8	R-1128-CFX	R1128X
	10	R-1160-CFX	R1160X

Other sizes on request. Bolts and nuts are not included in complete part numbers. For recommended bolts and nuts see page 55.



TFV - Flare flange connection

Tube to port connection

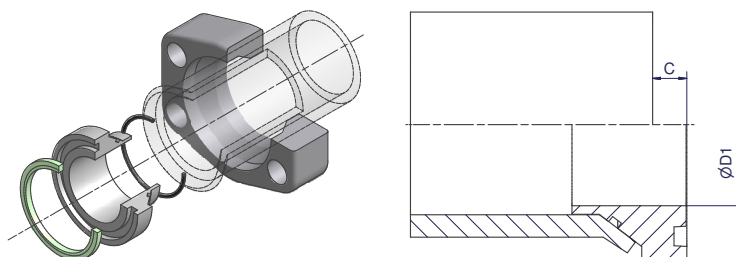

Size Inch	Tube	Flange incl. Insert F37 Seal + O-Ring Order code	D1	C	Insert incl. F37 Seal + O-Ring Order code	O-Ring Tube Side Order code	F37 Seal Port Side Order code	Weight (Steel) kg/1 kit
1 1/2	50X3.0	F37-124-50X3.0TFVCF	36.0	11	IN24-50X3.0TFVCF	OR44.17X1.78X	F37S24X	0.72
2	60X3.0	F37-132-60X3.0TFVCF	46.0	12	IN32-60X3.0TFVCF	OR53.7X1.78X	F37S32X	1.10
2 1/2	75X3.0	F37-140-75X3.0TFVCF	60.0	10	IN40-75X3.0TFVCF	OR69.57X1.78X	F37S40X	1.46
3	90X3.5	F37-148-90X3.5TFVCF	72.0	15	IN48-90X3.5TFVCF	OR82.27X1.78X	F37S48X	2.17
3 1/2	100x4.0	F37-156-100X4.0TFVCF	88.6	15	IN56-100X4.0TFVCF	OR94.97X1.78X	F37S56X	2.60
4	115X4.0	F37-164-115X4.0TFVCF	90.0	14	IN64-115X4.0TFVCF	OR110X2X	F37S64X	3.53
5	140X4.5	F37-180-140X4.5TFVCF	122.0	15	IN80-140X4.5TFVCF	OR129.77X3.53X	F37S80X	4.09
6	165X5.0	F37-196-165X5.0TFVCF	150.8	17	IN96-165X5.0TFVCF	OR158.42X2.26X	F37S196X	6.98
8	220X6.0	F37-1128-220X6.0TFVCF	203.3	16	IN128-220X6.0TFVCF	OR209.22X2.62X	F37S1128X	12.66
10	273X6.0	F37-1160-273X6.0TFVCF	256.2	17	IN160-273X6.0TFVCF	OR262.34X3.53X	F37S1160X	28.78

Other sizes on request.

Please change suffixes according to material/surface required

Order code suffixes		
Material	Suffix surface and material	Example
Steel, zinc plated, Cr(VI)-free	CF	F37-124-50X3.0TFVCF
Stainless steel	SS	F37-124-50X3.0TFVSS

TF – Flare flange connection

Tube to port connection, flat face

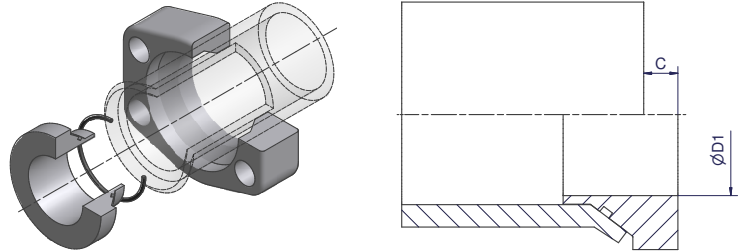

Size Inch	Tube	Flange incl. Insert + O-Ring Order code	D1	C	Insert incl. O-Ring Order code	O-Ring Tube Side Order code	Weight (Steel) kg/1 kit
1 1/2	50X3.0	F37-124-50X3.0TFCF	36.0	11	IN24-50X3.0TFCF	OR44.17X1.78X	0.72
2	60X3.0	F37-132-60X3.0TFCF	46.0	12	IN32-60X3.0TFCF	OR53.7X1.78X	1.10
2 1/2	75X3.0	F37-140-75X3.0TFCF	60.0	10	IN40-75X3.0TFCF	OR69.57X1.78X	1.46
3	90X3.5	F37-148-90X3.5TFCF	72.0	15	IN48-90X3.5TFCF	OR82.27X1.78X	2.17
3 1/2	100X4.0	F37-156-100X4.0TFCF	88.6	15	IN56-100X4.0TFCF	OR94.97X1.78X	2.60
4	115X4.0	F37-164-115X4.0TFCF	90.0	14	IN64-115X4.0TFCF	OR110X2X	3.60
5	140X4.5	F37-180-140X4.5TFCF	122.0	15	IN80-140X4.5TFCF	OR129.77X3.53X	4.14
6	165X5.0	F37-196-165X5.0TFCF	150.8	17	IN96-165X5.0TFCF	OR158.42X2.62X	7.03
8	220X6.0	F37-1128-220X6.0TFCF	203.3	16	IN128-220X6.0TFCF	OR209.22X2.62X	12.85
10	273X6.0	F37-1160-273X6.0TFCF	256.2	17	IN160-273X6.0TFCF	OR262.34X3.53X	29.01

Other sizes on request.

Please change suffixes according to material/surface required

Order code suffixes		
Material	Suffix surface and material	Example
Steel, zinc plated, Cr(VI)-free	CF	IN24-50X3.0TFCF
Stainless steel	SS	IN24-50X3.0TFSS



TT – Flare flange connection

Tube to tube connection

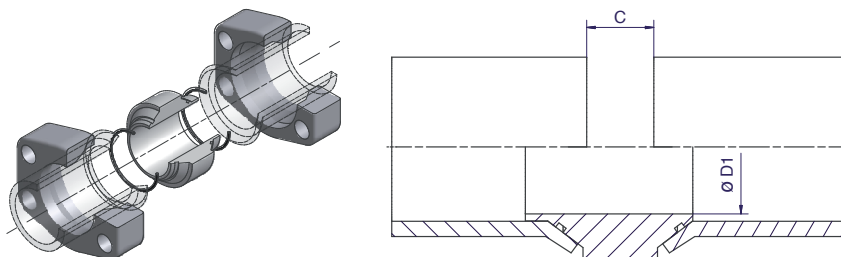

Size Inch	Tube	Flange incl. Insert + 2 x O-Ring Order code	D1	C	Insert incl. 2 x O-Ring Order code	O-Ring Tube Side Order code	Weight (Steel) kg/1 kit
1 1/2	50X3.0	F37-124-50X3.0TTCF	36.0	22	IN24-50X3.0TTCF	OR44.17X1.78X	0.94
2	60X3.0	F37-132-60X3.0TTCF	46.0	24	IN32-60X3.0TTCF	OR53.7X1.78X	1.38
2 1/2	75X3.0	F37-140-75X3.0TTCF	60.0	20	IN40-75X3.0TTCF	OR69.57X1.78X	1.79
3	90X3.5	F37-148-90X3.5TTCF	72.0	30	IN48-90X3.5TTCF	OR82.27X1.78X	2.79
3 1/2	100X4.0	F37-156-100X4.0TTCF	88.6	30	IN56-100X4.0TTCF	OR94.97X1.78X	2.60
4	115X4.0	F37-164-115X4.0TTCF	90.0	28	IN64-115X4.0TTCF	OR110X2X	4.45
5	140X4.5	F37-180-140X4.5TTCF	122.0	30	IN80-140X4.5TTCF	OR129.77X3.53X	4.75
6	165X5.0	F37-196-165X5.0TTCF	150.8	34	IN96-165X5.0TTCF	OR158.42X2.62X	8.36
8	220X6.0	F37-1128-220X6.0TTCF			on request		
10	273X6.0	F37-1160-273X6.0TTCF			on request		

Other sizes on request.

Please change suffixes according to material/surface required

Order code suffixes		
Material	Suffix surface and material	Example
Steel, zinc plated, Cr(VI)-free	CF	F37-124-50X3.0TTCF
Stainless Steel	SS	F37-124-50X3.0TTSS

R – Retaining ring

SAE 1000/ISO 6162-1 footprint

Size Inch	Order code	S	D
1 1/2	R124X	4.0	56.0
2	R132X	4.0	66.0
2 1/2	R140X	4.0	77.0
3	R148X	5.0	93.0
3 1/2	R156X	5.0	110.0
4	R164X	5.0	120.0
5	R180X	6.0	144.0
6	R196X	6.0	174.0
8	R1128X	8.0	232.0
10	R1160X	8.0	286.0

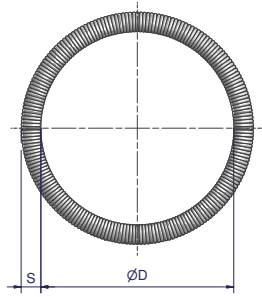

MTF-R – Male thread adapter, BSPP

SAE 1000/ISO 6162-1 footprint

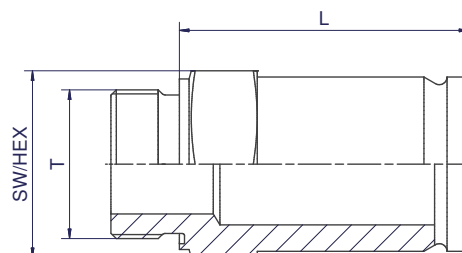
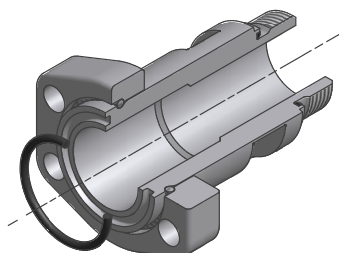

Size Inch	Complete part Order code	Body incl. ED-Seal Order code	L	T	SW/ HEX	Weight body (Steel) kg/1 piece
1 1/2	R-124MTFRCF	MTF124ROMDCF	93	G 1 1/2 A	60	1.29
1 1/2	R-124MTFR11/4CF	MTF124R11/4OMDCF	95	G 1 1/4 A	60	1.32
2	R-132MTFR2CF	MTF132R2OMDCF	97	G 2 A	60	1.83
2	R-132MTFR11/2CF	MTF132R11/2OMDCF	99	G 1 1/2 A	60	1.72
2 1/2	R-140MTFR2CF	MTF140R2OMDCF	136	G 2 A	85	3.32
2 1/2	R-140MTFRCF	MTF140ROMDCF	134	G 2 1/2 A	85	3.34
3	R-148MTFR21/2CF	MTF148R21/2OMDCF	147	G 2 1/2 A	100	4.63
3	R-148MTFRCF	MTF148ROMDCF	145	G 3 A	100	4.97

Other sizes on request.

Please change suffixes according to material/surface required

Order code suffixes		
Material	Suffix surface and material	Example
Steel, zinc plated, Cr(VI)-free	CF	R-120MTFR1CF
Stainless steel	SS	R-120MTFR1SS

FTF-R – Female thread adapter, BSPP

SAE 1000/ISO 6162-1 footprint

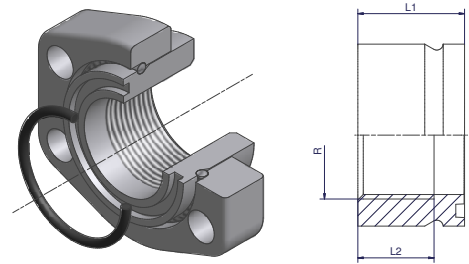

Size Inch	Complete part Order code	Adapter Order code	L1	L2	R	Weight (Steel) kg/1 kit
1 1/2	R-124FTFR11/4CF	FTF124R11/4CFX	45	30	G 1 1/4	0.54
2	R-132FTFR11/2CF	FTF132R11/2CFX	55	40	G 1 1/2	0.92
2 1/2	R-140FTFR2CF	FTF140R2CFX	80	40	G 2	1.58
3	R-148FTFR21/2CF	FTF148R21/2CFX	85	50	G 2 1/2	2.18

Other sizes on request.

Please change suffixes according to material/surface required

Order code suffixes		
Material	Suffix surface and material	Example
Steel, zinc plated, Cr(VI)-free	CF	R-120FTFR1CF
Stainless steel	SS	R-120FTFR1SS



WA – Weld adapter connection

SAE 1000/ISO 6162-1 footprint

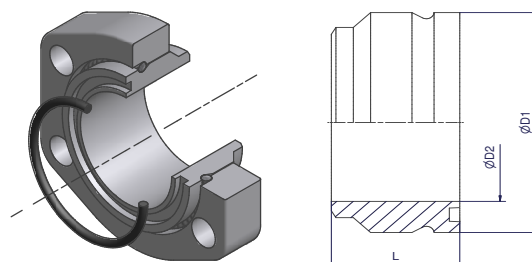

Size Inch	Tube	Complete Part Order code	Weld Adapter Body Order code	Flange Order code	Retaining Ring	O-Ring	D1	D2	L	Weight (Steel) kg/1 kit
1 1/2	50.0X3.0	R-124WA-50X3.0S	WA124-50X3.0SX	R-124-CFX	R124X	OR47.22X3.53X	59.7	39.8	35.0	0.80
1 1/2	48.3X2.6	R-124WA-48.3X2.6S	WA124-48.3X2.6SX	R-124-CFX	R124X	OR47.22X3.53X	59.7	39.8	35.0	0.80
2	60.0X3.0	R-132WA-60X3.0S	WA132-60X3.0SX	R-132-CFX	R132X	OR56.75X3.53X	69.7	50.0	35.0	0.99
2	60.3X2.9	R-132WA-60.3X2.9S	WA132-60.3X2.9SX	R-132-CFX	R132X	OR56.75X3.53X	69.7	50.0	35.0	0.99
2 1/2	75.0X3.0	R-140WA-75X3.0S	WA140-75X3.0SX	R-140-CFX	R140X	OR69.44X3.53X	80.7	62.0	35.0	1.21
2 1/2	76.1X3.2	R-140WA-76.1X3.2S	WA140-76.1X3.2SX	R-140-CFX	R140X	OR69.44X3.53X	80.7	62.0	35.0	1.21
3	88.9X3.05	R-148WA-88.9X3.05S	WA148-88.9X3.05SX	R-148-CFX	R148X	OR85.32X3.53X	97.7	77.8	40.0	1.92
3	88.9X3.6	R-148WA-88.9X3.6S	WA148-88.9X3.6SX	R-148-CFX	R148X	OR85.32X3.53X	97.7	77.8	40.0	1.92
3 1/2	100X4.0	R-156WA-100X4.0S	WA156-100X4.0SX	R-156-CFX	R156X	OR98.02X3.53X	114.7	89.8	40.0	2.70
4	114.3X4.5	R-164WA-114.3X4.5S	WA164-114.3X4.5SX	R-164-CFX	R164X	OR110.72X3.53X	124.7	99.8	40.0	3.11
4	115X4.0	R-164WA-115X4.0S	WA164-115X4.0SX	R-164-CFX	R164X	OR110.72X3.53X	124.7	99.8	40.0	3.09
5	139.7X5.6	R-180WA-139.7X5.6S	WA180-139.7X5.6SX	R-180-CFX	R180X	OR136.12X3.53X	149.7	124.8	45.0	4.92
5	140X4.5	R-180WA-140X4.5S	WA180-140X4.5SX	R-180-CFX	R180X	OR136.12X3.53X	149.7	124.8	45.0	4.87
5	141.3X3.4	R-180WA-141.3X3.4S	WA180-141.3X3.4SX	R-180-CFX	R180X	OR136.12X3.53X	149.7	124.8	45.0	4.91
6	165X5.0	R-196WA-165X5.0S	WA196-165X5.0SX	R-196-CFX	R196X	OR158.34X3.53X	179.7	149.8	50.0	8.02
6	168.3X2.77	R-196WA-168.3X2.77S	WA196-168.3X2.77SX	R-196-CFX	R196X	OR158.34X3.53X	179.7	149.8	50.0	8.06
6	168.3X3.4	R-196WA-168.3X3.4S	WA196-168.3X3.4SX	R-196-CFX	R196X	OR158.34X3.53X	179.7	149.8	50.0	8.06
8	219.1X3.76	R-1128WA-219.1X3.76S	WA1128-219.1X3.76SX	R-1128-CFX	R1128X	OR219.3X5.7X	239.7	206.5	60.0	13.55
8	219.1X8.18	R-1128WA-219.1X8.18S	WA1128-219.1X8.18SX	R-1128-CFX	R1128X	OR219.3X5.7X	239.7	206.5	60.0	13.55
8	220X6.0	R-1128WA-220X6.0S	WA1128-220X6.0SX	R-1128-CFX	R1128X	OR219.3X5.7X	239.7	208.0	60.0	13.62
10	273X6.0	R-1160WA-273X6.0S	WA1160-273X6.0SX	R-1160-CFX	R1160X	OR269.3X5.7X	295.0	255.0	70.0	32.23
10	274.1X9.27	R-1160WA-274.1X9.27S	WA1160-274.1X9.27SX	R-1160-CFX	R1160X	OR269.3X5.7X	295.0	255.0	70.0	32.39

Other sizes on request.

Please change suffixes according to material/surface required

Order code suffixes		
Material	Suffix surface and material	Example
Steel	S	R-124WA-50x3.0S
Stainless steel	SS	R-124WA-50x3.0SS

WAF – Weld adapter flat connection

SAE 1000/ISO 6162-1 footprint

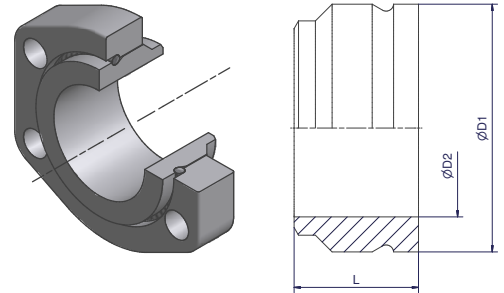

Size Inch	Tube	Complete Part Order code	Weld Adapter Body Order code	Flange Order code	Retaining Ring	D1	D2	L	Weight (Steel) kg/1 kit
1 1/2	50.0X3.0	R-124WA-50X3.0FS	WA124-50X3.0FSX	R-124-CFX	R124X	59.7	39.8	35.0	0.80
1 1/2	48.3X2.6	R-124WA-48.3X2.6FS	WA124-48.3X2.6FSX	R-124-CFX	R124X	59.7	39.8	35.0	0.80
2	60.0X3.0	R-132WA-60X3.0FS	WA132-60X3.0FSX	R-132-CFX	R132X	69.7	50.0	35.0	0.99
2	60.3X2.9	R-132WA-60.3X2.9FS	WA132-60.3X2.9FSX	R-132-CFX	R132X	69.7	50.0	35.0	1.01
2 1/2	75.0X3.0	R-140WA-75X3.0FS	WA140-75.0X3.0FSX	R-140-CFX	R140X	80.7	62.0	35.0	1.21
2 1/2	76.1X3.2	R-140WA-76.1X3.2FS	WA140-76.1X3.2FSX	R-140-CFX	R140X	80.7	62.0	35.0	1.21
3	88.9X3.05	R-148WA-88.9X3.05FS	WA148-88.9X3.05FSX	R-148-CFX	R148X	97.7	77.8	40.0	1.94
3	88.9X3.6	R-148WA-88.9X3.6FS	WA148-88.9X3.6FSX	R-148-CFX	R148X	97.7	77.8	40.0	1.94
3 1/2	100X4.0	R-156WA-100X4.0FS	WA156-100X4.0FSX	R-156-CFX	R156X	114.7	89.8	40.0	2.73
4	114.3X4.5	R-164WA-114.3X4.5FS	WA164-114.3X4.5FSX	R-164-CFX	R164X	124.7	99.8	40.0	3.15
4	115X4.0	R-164WA-115X4.0FS	WA164-115X4.0FSX	R-164-CFX	R164X	124.7	99.8	40.0	3.13
5	139.7X5.6	R-180WA-139.7X5.6FS	WA180-139.7X5.6FSX	R-180-CFX	R180X	149.7	124.8	45.0	4.96
5	140X4.5	R-180WA-140X4.5FS	WA180-140x4.5FSX	R-180-CFX	R180X	149.7	124.8	45.0	4.92
5	141.3X3.4	R-180WA-141.3X3.4FS	WA180-141.3X3.4FSX	R-180-CFX	R180X	149.7	124.8	45.0	4.93
6	165X5.0	R-196WA-165X5.0FS	WA196-165X5.0FSX	R-196-CFX	R196X	179.7	149.8	50.0	8.08
6	168.3X2.77	R-196WA-168.3X2.77FS	WA196-168.3X2.77FSX	R-196-CFX	R196X	179.7	149.8	50.0	8.16
6	168.3X3.4	R-196WA-168.3X3.4FS	WA196-168.3X3.4FSX	R-196-CFX	R196X	179.7	149.8	50.0	8.16
8	219.1X3.76	R-1128WA-219.1X3.76FS	WA1128-219.1X3.76FSX	R-1128-CFX	R1128X	239.7	206.5	60.0	13.75
8	219.1X8.18	R-1128WA-219.1X8.18FS	WA1128-219.1X8.18FSX	R-1128-CFX	R1128X	239.7	206.5	60.0	13.75
8	220X6.0	R-1128WA-220X6.0FS	WA1128-220X6.0FSX	R-1128-CFX	R1128X	239.7	208.0	60.0	13.81
10	273X6.0	R-1160WA-273X6FS	WA1160-273X6FSX	R-1160-CFX	R1160X	295.0	255.0	70.0	32.47
10	274.1X9.27	R-1160WA-274.1X9.27FS	WA1160-274.1X9.27FSX	R-1160-CFX	R1160X	295.0	255.0	70.0	32.49

Other sizes on request.

Please change suffixes according to material/surface required

Order code suffixes		
Material	Suffix surface and material	Example
Steel	S	R-124WA-50X3.0FS
Stainless steel	SS	R-124WA-50X3.0FSS



BF – Bulkhead flange flat face

SAE 1000/ISO 6162-1 footprint

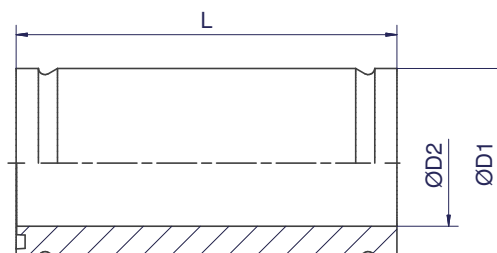
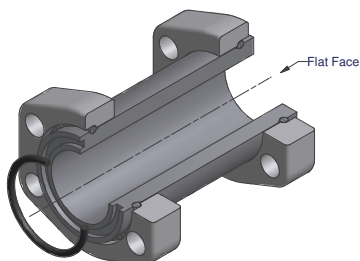

Size Inch	Complete Part Order code	Bulkhead Body Order code	O-Ring	D1	D2	L	Weight body (Steel) kg/1 piece
1 1/2	R-124FBFS	BF124FSX	OR47.22X3.53X	59.7	39.8	165	1.98
2	R-132FBFS	BF132FSX	OR56.75X3.53X	69.7	50.0	165	2.34
2 1/2	R-140FBFS	BF140FSX	OR69.44X3.53X	80.7	62.0	175	2.81
3	R-148FBFS	BF148FSX	OR85.32X3.53X	97.7	77.8	200	4.20
3 1/2	R-156FBFS	BF156FSX	OR98.02X3.53X	114.7	89.8	200	6.15
4	R-164FBFS	BF164FSX	OR110.72X3.53X	124.7	99.8	200	6.75
5	R-180FBFS	BF180FSX	OR136.12X3.53X	149.7	124.8	200	8.22
6	R-196FBFS	BF196FSX	OR158.34X3.53X	179.7	149.8	215	12.81
8	R-1128FBFS	BF1128FSX	OR219.3X5.7X	239.7	206.5	240	21.18
10	R-1160FBFS	BF1160FSX	OR269.3X5.7X	295.0	255.0	270	35.59

Other sizes on request.

Please change suffixes according to material/surface required

Order code suffixes		
Material	Suffix surface and material	Example
Steel	S	R-132FBFS
Stainless steel	SS	R-132FBFSS

Parflange® F37 – SAE 1000/ISO 6162-1 footprint

RF – Reducer flange flat face

SAE 1000/ISO 6162-1 footprint

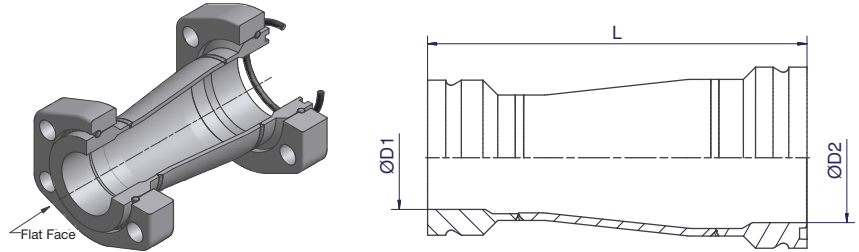

Size Inch	Complete Part Order code	Reducer Body Order code	O-Ring	D1	D2	L	Weight body (Steel) kg/1 piece	W.P. bar
2 - 1 1/2	R-132-124FRFCF	RF132-124FOMDCF	OR56.75X3.53X	39.8	50.0	146	0.91	70
2 1/2 - 1 1/2	R-140-124FRFCF	RF140-124FOMDCF	OR69.44X3.53X	39.8	62.0	160	1.04	70
2 1/2 - 2	R-140-132FRFCF	RF140-132FOMDCF	OR69.44X3.53X	50.0	62.0	160	1.25	70
3 - 1 1/2	R-148-124FRFCF	RF148-124FOMDCF	OR85.32X3.53X	39.8	77.8	165	1.34	70
3 - 2	R-148-132FRFCF	RF148-132FOMDCF	OR85.32X3.53X	50.0	77.8	165	1.45	70
3 - 2 1/2	R-148-140FRFCF	RF148-140FOMDCF	OR85.32X3.53X	62.0	77.8	168	1.53	70
3 1/2 - 2 1/2	R-156-140FRFCF	RF156-140FOMDCF	OR98.02X3.53X	62.0	89.8	177	2.00	50
3 1/2 - 3	R-156-148FRFCF	RF156-148FOMDCF	OR98.02X3.53X	77.8	89.8	182	2.32	50
4 - 3	R-164-148FRFCF	RF164-148FOMDCF	OR110.72X3.53X	77.8	99.8	182	2.43	50
5 - 4	R-180-164FRFCF	RF180-164FOMDCF	OR136.12X3.53X	99.8	124.8	214	3.86	50

Other sizes on request.

Please change suffixes according to material/surface required

Order code suffixes		
Material	Suffix surface and material	Example
Steel, zinc plated, Cr(VI)-free	CF	RF132-124-FRFCF
Stainless steel	SS	RF132-124-FRFSS



LF – Elbow flange flat face

SAE 1000/ISO 6162-1 footprint

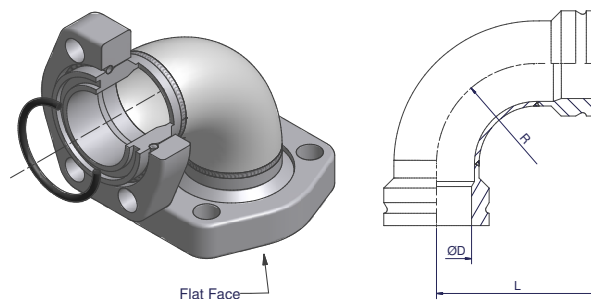

Size Inch	Elbow Flange Complete Part Order code	Elbow Flange body Order code	O-Ring	D	L	R	Weight body (Steel) kg/1 piece	W.P. bar
1 1/2	R-124FLFCF	LF124FOMDCF	OR47.22X3.53X	39.8	94	57.0	0.85	70
2	R-132FLFCF	LF132FOMDCF	OR56.75X3.53X	50.0	112	76.0	1.18	70
2 1/2	R-140FLFCF	LF140FOMDCF	OR69.44X3.53X	62.0	132	95.0	1.54	70
3	R-148FLFCF	LF148FOMDCF	OR85.32X3.53X	77.8	155	114.0	2.44	70
3 1/2	R-156FLFCF	LF156FOMDCF	OR98.02X3.53X	88.9	184	142.5	3.88	50
4	R-164FLFCF	LF164FOMDCF	OR110.72X3.53X	99.8	195	152.0	4.33	50
5	R-180FLFCF	LF180FOMDCF	OR136.12X3.53X	124.8	235	190.0	6.81	50
6	R-196FLFCF	LF196FOMDCF	OR158.34X3.53X	149.8	304	229.0	11.19	50
8	R-1128FLFCF	LF1128FOMDCF	OR219.3X5.7X	206.5	390	305.0	24.13	50
10	R-1160FLFCF	LF1160FOMDCF	OR269.3X5.7X	255.0	471	381.0	38.39	50

Other sizes on request.

Please change suffixes according to material/surface required

Order code suffixes		
Material	Suffix surface and material	Example
Steel, zinc plated, Cr(VI)-free	CF	R-124FLFCF
Stainless steel	SS	R-124FLFSS

TF/TF-R – TEE flange flat

SAE 1000/ISO 6162-1 footprint

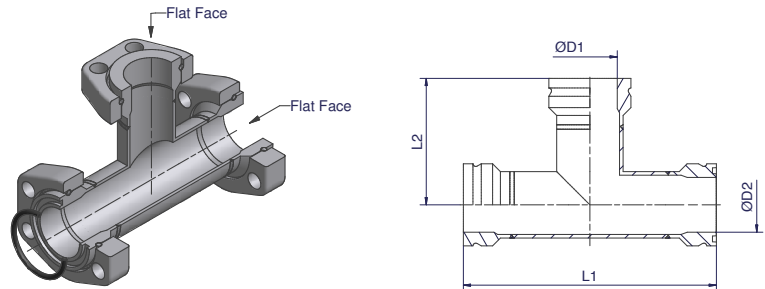

Size Inch	Tee Flange Complete Part Order code	Tee Flange Body Order code	O-Ring	D1	D2	L1	L2	Weight body (Steel) kg/1 piece	W.P. bar
1 1/2	R-124FTFCF	TF124FOMDCF	OR47.22X3.53X	39.8	39.8	184	92	1.30	70
2-1 1/2-2	R-132-124-132FTFCF	TF132-124-132FOMDCF	OR56.75X3.53X	39.8	50.0	200	97	1.58	70
2	R-132FTFCF	TF132FOMDCF	OR56.75X3.53X	50.0	50.0	198	99	1.67	70
2 1/2-2-21/2	R-140-132-140FTFCF	TF140-132-140FOMDCF	OR69.44X3.53X	50.0	62.0	222	105	2.02	70
2 1/2	R-140FTFCF	TF140FOMDCF	OR69.44X3.53X	62.0	62.0	222	111	2.09	70
3-2 1/2-3	R-148-140-148FTFCF	TF148-140-148FOMDCF	OR85.32X3.53X	62.0	77.8	252	118	2.91	70
3	R-148FTFCF	TF148FOMDCF	OR85.32X3.53X	77.8	77.8	252	126	3.22	70
3 1/2-3-3 1/2	R-156-148-156FTFCF	TF156-148-156FOMDCF	OR98.02X3.53X	77.8	89.8	283	137	4.47	50
3 1/2	R-156FTFCF	TF156FOMDCF	OR98.02X3.53X	89.8	89.8	283	140	4.86	50
4-3-4	R-164-148-164FTFCF	TF164-148-164FOMDCF	OR110.72X3.53X	77.8	99.8	293	138	4.84	50
4	R-164FTFCF	TF164FOMDCF	OR110.72X3.53X	99.8	99.8	293	145	5.37	50
5-4-5	R-180-164-180FTFCF	TF180-164-180FOMDCF	OR136.12X3.53X	99.8	124.8	340	157	7.39	50
5	R-180FTFCF	TF180FOMDCF	OR136.12X3.53X	124.8	124.8	341	169	8.04	50
6-5-6	R-196-180-196FTFCF	TF196-180-196FOMDCF	OR158.34X3.53X	124.8	149.8	426	188	11.49	50
6	R-196FTFCF	TF196FOMDCF	OR158.34X3.53X	149.8	149.8	439	218	12.87	50
8-6-8	R-1128-196-1128FTFCF	TF1128-196-1128FOMDCF	OR219.3X5.7X	149.8	206.5	528	243	22.66	50
8	R-1128FTFCF	TF1128FOMDCF	OR219.3X5.7X	206.5	206.5	529	263	25.58	50
10	R-1160FTFCF	TF1160FOMDCF	OR269.3X5.7X	255.0	255.0	612	306	40.16	50

Other sizes on request.

Please change suffixes according to material/surface required

Order code suffixes		
Material	Suffix surface and material	Example
Steel, zinc plated, Cr(VI)-free	CF	R-124FTFCF
Stainless steel	SS	R-124FTFSS



BFV – Blind flange

SAE 1000/ISO 6162-1

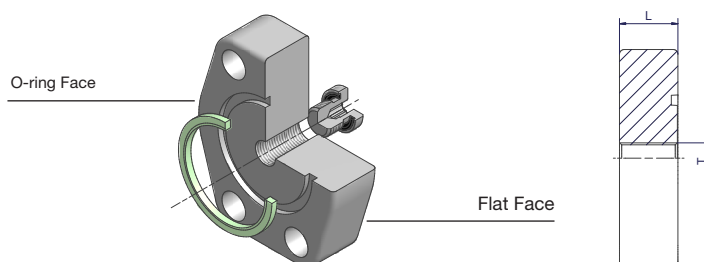

Size Inch	Flange incl. VSTI-ED and Seal Order code	L	T	Weight body (Steel) kg/1 piece
1 1/2	F37-124BFVCF	20	G 1/4	0.9
2	F37-132BFVCF	25	G 1/4	1.5
2 1/2	F37-140BFVCF	30	G 1/4	2.3
3	F37-148BFVCF	30	G 1/4	3.2
3 1/2	F37-156BFVCF	30	G 1/4	4.0
4	F37-164BFVCF	39	G 1/4	6.1
5	F37-180BFVCF	39	G 1/4	8.3
6	F37-196BFVCF	39	G 1/4	12.9
8	F37-1128BFVCF	39	G 1/4	23.1
10	F37-1160BFVCF	50	G 1/4	50.2

Other sizes on request.

Please change suffixes according to material/surface required

Order code suffixes		
Material	Suffix surface and material	Example
Steel, zinc plated, Cr(VI)-free	CF	F37-124BFVCF
Stainless steel	SS	F37-124BFVSS

Parflange® F37 – SAE 1000/ISO 6162-1 footprint

CPML – F37 inner plate

SAE 1000/ISO 6162-1 footprint

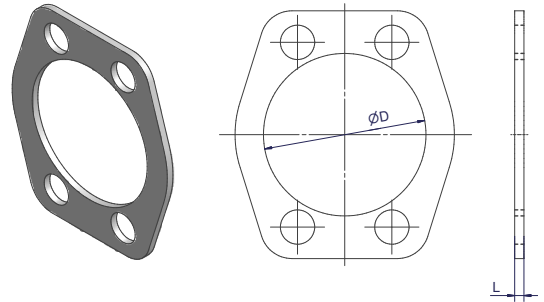

Size Inch	F37 Inner Plate Order code	L	D	Weight (Steel) kg/1 piece
1 1/2	24CPMLCFX	3.5	39.8	0.13
2	32CPMLCFX	3.5	50.0	0.15
2 1/2	40CPMLCFX	3.5	62.0	0.19
3	48CPMLCFX	3.5	77.8	0.25
3 1/2	56CPMLCFX	3.5	89.8	0.30
4	64CPMLCFX	3.5	99.8	0.34
5	80CPMLCFX	3.5	124.8	0.41
6	96CPMLCFX	3.5	149.8	0.68
8	128CPMLCFX	4.5	206.5	1.52
10	160CPMLCFX	4.5	255.0	2.75

Other sizes on request.

Please change suffixes according to material/surface required.

Order code suffixes		
Material	Suffix surface and material	Example
Steel	CF	24CPMLCFX
Stainless steel	SS	24CPMLSSX

F37S/F37RS – F37 seal

SAE 1000/ISO 6162-1

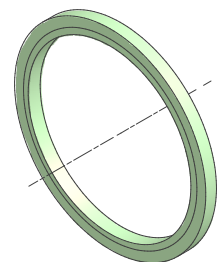

Size Inch	F37 Seal (F37 seal for flaring system)
1 1/2	F37S24X
2	F37S32X
2 1/2	F37S40X
3	F37S48X
3 1/4	F37S56X
4	F37S64X
5	F37S80X
6	F37S196X
8	F37S1128X
10	F37S1160X

Sealing: Polyurethane
Material properties and applications see page 22.
Other sizes on request.



Bolts and nuts for flange

SAE 1000/ISO 6162-1 footprint



F37 Flare Flange

Size Inch	Flange	Soft Seal / Flat Face		Nut
		Recommended bolts Tube to Port	Recommended bolts Tube to Tube	
1 1/2	F37-124-CFX	4 x ZYLS12X40	4 x ZYLS12X70	4 x ISO4032-M12
2	F37-132-CFX	4 x ZYLS12X45	4 x ZYLS12X80	4 x ISO4032-M12
2 1/2	F37-140-CFX	4 x ZYLS12X50	4 x ZYLS12X90	4 x ISO4032-M12
3	F37-148-CFX	4 x ZYLS16X60	4 x ZYLS16X100	4 x ISO4032-M16
3 1/2	F37-156-CFX	4 x ZYLS16X60	4 x ZYLS16X100	4 x ISO4032-M16
4	F37-164-CFX	4 x ZYLS16X65	4 x ZYLS16X120	4 x ISO4032-M16
5	F37-180-CFX	4 x ZYLS16X65	4 x ZYLS16X120	4 x ISO4032-M16
6	F37-196-CFX	6 x ZYLS16X65	6 x ZYLS16X110	6 x ISO4032-M16
8	F37-1128-CFX	8 x ZYLS20X80	8 x ZYLS20X145	8 x ISO4032-M20
10	F37-1160-CFX	8 x ZYLS20X80	8 x ZYLS20X150	8 x ISO4032-M20

Retaining Ring Flange

Size Inch	Flange	Soft Seal / Flat Face		Nut
		Recommended bolts Tube to Port	Recommended bolts Tube to Tube	
1 1/2	R-124-CFX	4 x ZYLS12X40	4 x ZYLS12X65	4 x ISO4032-M12
2	R-132-CFX	4 x ZYLS12X40	4 x ZYLS12X65	4 x ISO4032-M12
2 1/2	R-140-CFX	4 x ZYLS12X40	4 x ZYLS12X65	4 x ISO4032-M12
3	R-148-CFX	4 x ZYLS16X50	4 x ZYLS16X80	4 x ISO4032-M16
3 1/2	R-156-CFX	4 x ZYLS16X55	4 x ZYLS16X90	4 x ISO4032-M16
4	R-164-CFX	4 x ZYLS16X55	4 x ZYLS16X90	4 x ISO4032-M16
5	R-180-CFX	4 x ZYLS16X70	4 x ZYLS16X110	4 x ISO4032-M16
6	R-196-CFX	6 x ZYLS16X70	6 x ZYLS16X110	6 x ISO4032-M16
8	R-1128-CFX	8 x ZYLS20X70	8 x ZYLS20X120	8 x ISO4032-M20
10	R-1160-CFX	8 x ZYLS20X80	8 x ZYLS20X150	8 x ISO4032-M20

Bolts and nuts are not included in complete part numbers.

Latest information about nuts and bolts see www.parker.com/hpce -> Resources -> Installation Guides & Manuals

Please add the suffixes according to the bolt quality

	Steel	Stainless Steel
Grade	8.8 zinc plated (VZX)	A4-80X
Bolt	ZYLS16X60VZX	ZYLS16X60A4-80X
Nut	ISO4032-M12-8VZX	ISO4032-M12-80X

AP – SAE flange locking plate

SAE 1000/ISO 6162-1

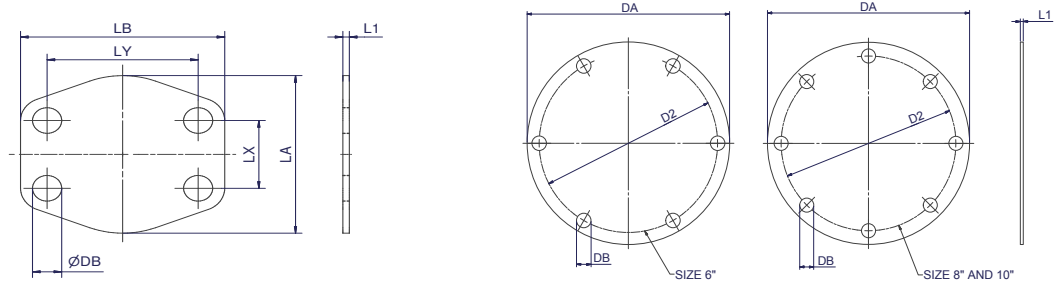

Nom. flange size		Order code	L1	LA	LB	LX	LY	DB	Weight body (Steel) kg/1 piece
SAE (In)	ISO (DN)								
1 1/2	38	24AP1	3	83	94	35.7	69.9	13.5	0.02
2	51	32AP1	3	97	102	42.9	77.8	13.5	0.02
2 1/2	64	40AP1	3	109	114	50.8	88.9	13.5	0.03
3	76	48AP1	4	131	135	61.9	106.4	17.0	0.06
3 1/2	89	56AP1	4	140	152	69.9	120.7	17.0	0.07
4	102	64AP1	4	146	162	77.8	130.2	17.0	0.08
5	127	80AP1	4	181	184	92.1	152.4	17.0	0.11
				DA		D2		DB	
6		96AP1	3.5	236		208		17.0	1.33
8		128AP1	4	318		275		22.0	2.40
10		160AP1	4	409		345		22.0	4.04

This flange locking plate to be not used under pressure!

Please change suffixes according to material/surface required

Order code suffixes			
Material	Suffix surface and material	Example	Description
Steel, zinc plated, Cr(VI)-free	CF	8AP1CF	only locking plate
Stainless steel	SS	8AP1SS	only locking plate
Steel (zinc plated, Cr(VI)-free), SBR 70 Shore A	CFSBR70	8AP1CFSBR70	locking incl. rubber plate L1 increases due to rubber plate



KH - Ball valve drilled and tapped for SAE Flanges

SAE 1000/ISO 6162-1 footprint

Material Steel

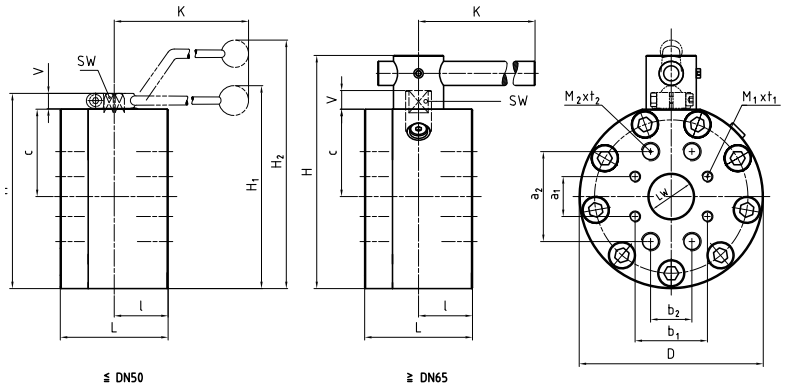

Size Inch	Order code	DN	LW	L	I	D	H	c	V	K	SW	SAE 3000 boring pattern				SAE 6000 boring pattern				H1	H2	Material Code	Lever	Weight-kg	W.P. bar
												a1	b1	M1	t1	a2	b2	M2	t2						
1 1/2	KH24-38CF	40	38	110	55	165	178	78	17	306	17	35.7	69.9	M12	20	79.4	36.5	M16	27	-	252	212A	St	17.10	210/420
2	KH32-48CF	50	48	116	58	198	210	94	17	306	17	42.9	77.8	M12	20	96.8	44.5	M20	28	-	284	212A	St	24.60	210/420
2 1/2	KH40-63CF	65	63	170	75	218	275	100	20	600	16	88.9	50.8	M12	19	123.8	58.7	M24	41	-	-	282A	St	44.40	175/420
3	KH48-76CF	80	76	170	79	258	315	115	26	600	19	106.4	61.9	M16	24	152.4	71.4	M30	47	-	-	282A	St	54.90	160/420

Steel ball valves 1 1/2" up to 3" with SAE 3000 and SAE 6000 boring pattern. The bore pattern for 2 1/2" and 3" is turned to 90°.

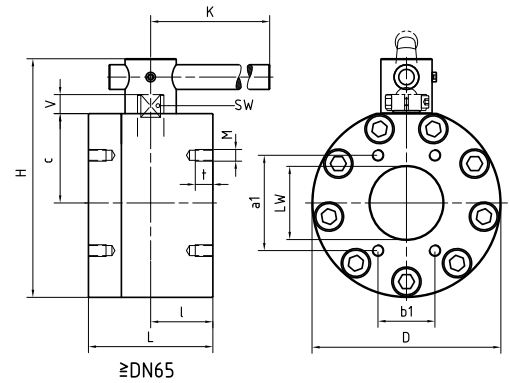
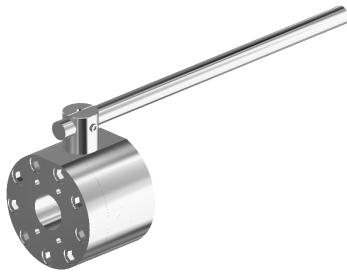

Size Inch	Order code	DN	LW	L	I	D	H	c	V	K	SW	a1	b1	M	t	Material Code	Lever	Weight-kg	W.P. bar
4	KH364-100CF	100	100	170	85	258	326	122	27	900	24	130.2	77.8	M16	24	282A	St	60.5	35
5	KH380-118CF	125	118	210	105	295	377	140	33	900	36	152.4	92.1	M16	30	282A	St	95.5	35

Steel ball valves 4" up to 5" with SAE 3000 only boring pattern. Other sizes on request.

Please change suffixes according to material/surface required

Order code suffixes		
Material	Suffix surface and material	Example
Steel, zinc plated, Cr(VI)-free	CF	KH32-48CF

	Material 212A	Material 282A
Body	Steel	Steel
Ball	Steel	Steel
Stem	Steel	Stainless Steel
Ball seats	POM	POM
O-Ring	NBR	NBR
Tmin / Tmax	-10°C / 100°C	-10°C / 100°C

KH - Ball valve drilled and tapped for SAE Flanges

SAE 1000/ISO 6162-1 footprint
Material Stainless Steel

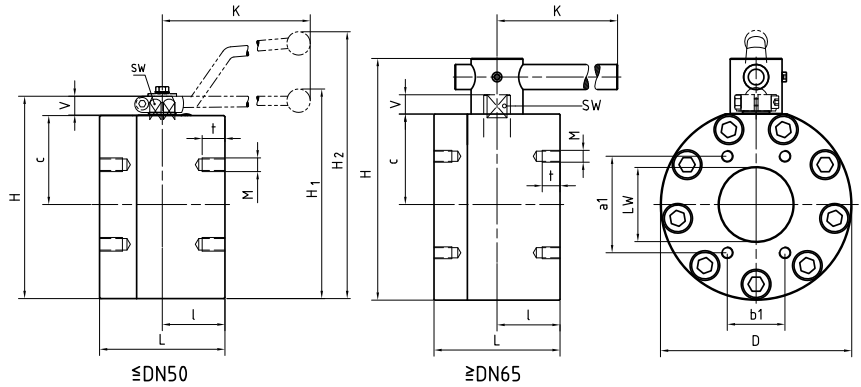
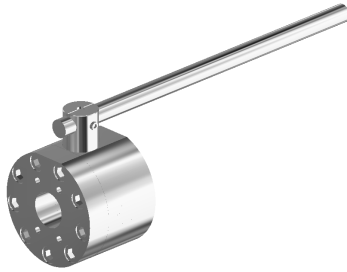

Size Inch	Order code	DN	LW	L	I	D	H	c	V	K	SW	a1	b1	M	t	H1	H2	Material Code	Lever	Weight-kg	W.P. bar
1 1/2	KH324-38SS	40	38	110	55	165	178	78	17	320	17	69.9	35.7	M12	20	187	-	442A	Al	17.1	210
2	KH332-48SS	50	48	116	58	198	210	94	17	320	17	77.8	42.9	M12	20	219	-	442A	Al	24.6	210
2 1/2	KH340-63SS	65	63	150	75	198	259	94	20	600	16	88.9	50.8	M12	19	-	-	442A	St	33.5	175
3	KH348-76SS	80	76	150	79	218	284	104	26	600	19	106.4	61.9	M16	24	-	-	442A	St	40.0	160
4	KH364-100SS	100	100	170	85	258	326	122	27	900	24	130.2	77.8	M16	24	-	-	442A	St	60.5	35
5	KH380-118SS*	125	118	210	105	295	377	140	33	900	36	152.4	92.1	M16	30	-	-	442A	St	95.5	35

Other sizes on request.

Please change suffixes according to material/surface required

Order code suffixes		
Material	Suffix surface and material	Example
Stainless steel	SS	KH32-48SS

Material 442A	
Body	Stainless Steel
Ball	Stainless Steel
Stem	Stainless Steel
Ball seats	POM
O-Ring	NBR
Tmin / Tmax	-30°C / 100°C

*For these ball valves Tmin / Tmax = -10°C / 100°C



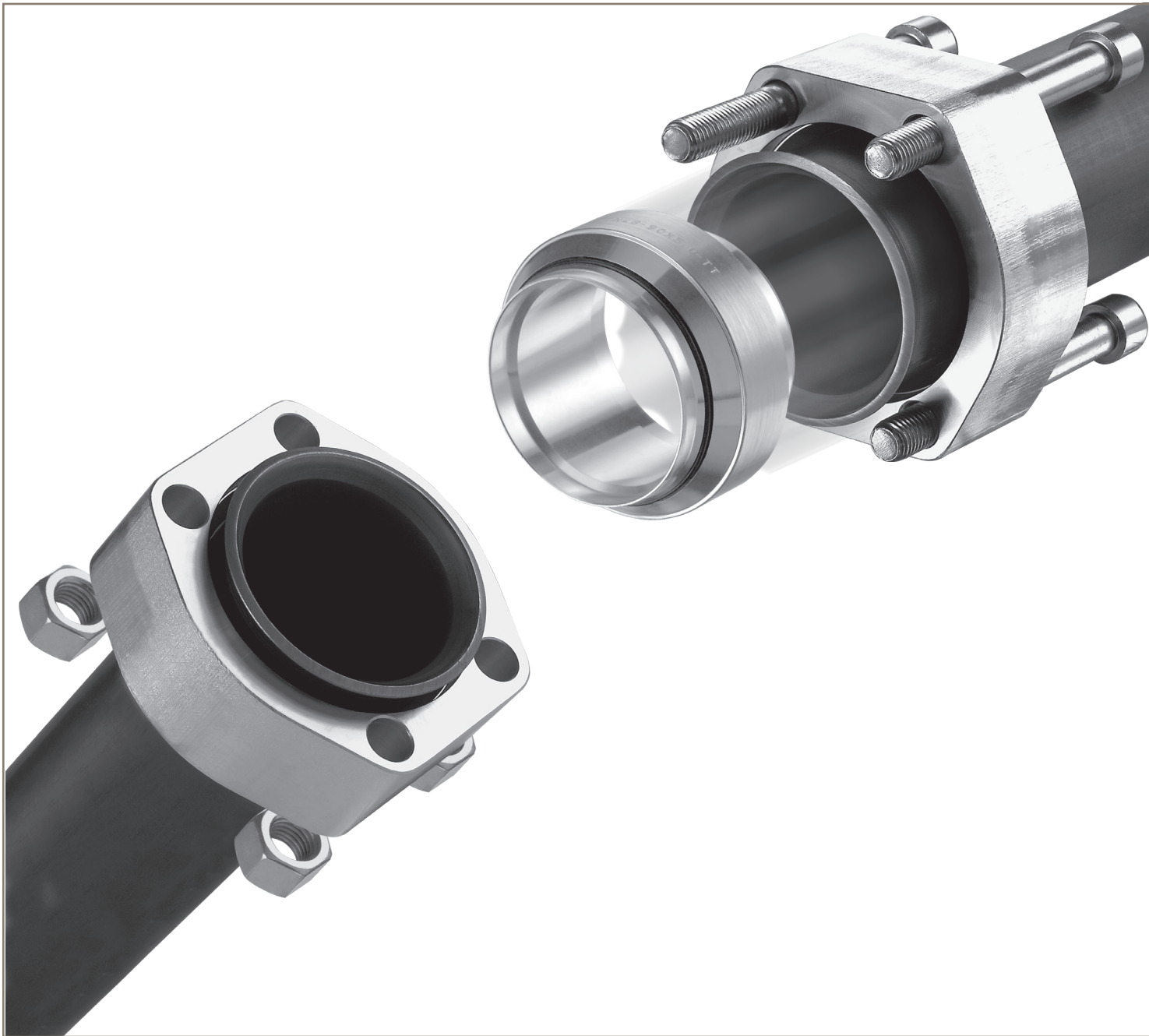









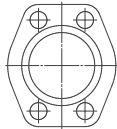
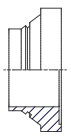
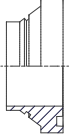
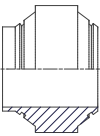

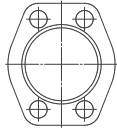

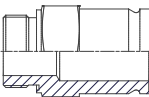
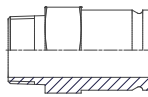

SAE 3000 System

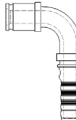
210 – 350 bar

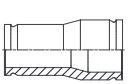
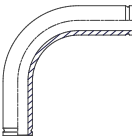
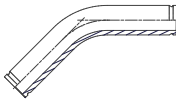
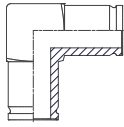
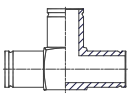
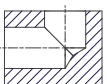
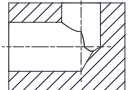
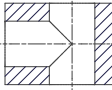
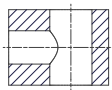
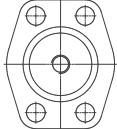
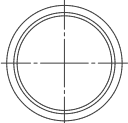
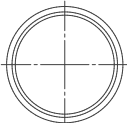
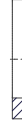
ENGINEERING YOUR SUCCESS.

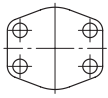
Programme overview SAE 3000/ISO 6162-1 footprint

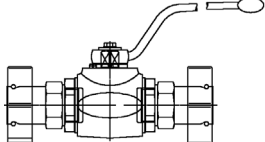
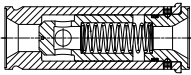
Parflange® F37 connection parts	Flanges  F37 – p.61/62					
	Inserts     TFB – p.65 TFV – p.66 TT – p.67 TF – p.68				Sleeve  SL – p.69	
Retaining ring connection parts	Flanges    R – p.63 R-Ring – p.70 PSC – p.64					
	Male / Female    MTF-R – p.71 MTF-N – p.72 FTF-R – p.73			Hose    Hose – p.74		Weld  WA – p.75/76
	Tube to Tube       BF – p.77 RF – p.78 FB90 – p.79/81 FB45 – p.80/82 LF – p.83 TF – p.84					
SAE connection parts	Blocks      LB – p.85 LBR – p.86 TB – p.87 TBR – p.88 BFV – p.89					
Seals Adapter Bolts	Components      BS – p.90 F37S – p.90 AO – p.91 TBT – p.92 AP – p.93				Bolts and Nuts  <p>p.94</p>	
Ball valves	   KH – p.95/96 KH-R – p.97 RHD-R – p.98					



F37 – Flare flange | SAE 3000/ISO 6162-1 footprint

SAE 3000/ISO 6162-1

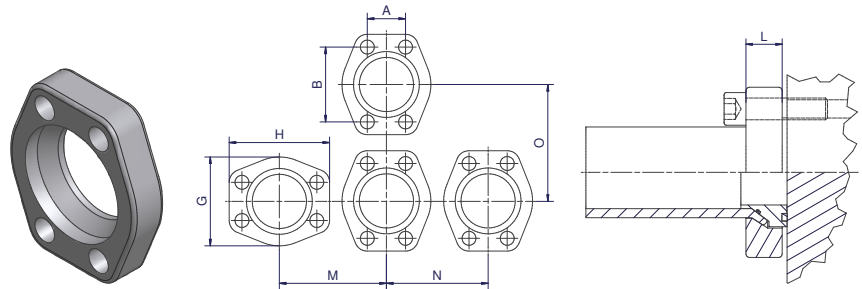

Parflange F37 flange dimensions

*Jump size flanges (no adapter sleeves (SL...) necessary).

Size Inch	Flange Order code	A	B	G	H	M	N	O	L	Weight body (Steel) kg/1 piece	W.P. bar
1/2	F37-308-CFX	17.5	38.1	46	54	55	51	59	19	0.17	350
1/2	F37-308/16-CFX*	17.5	38.1	46	54	55	51	59	19	0.22	350
1/2	F37-308/20-CFX*	17.5	38.1	46	54	55	51	59	19	0.20	350
3/4	F37-312-CFX	22.3	47.6	52	65	63	57	70	20	0.25	350
1	F37-316-CFX	26.2	52.4	60	71	69	64	75	24	0.30	350
1	F37-316/25-CFX*	26.2	52.4	60	71	69	64	75	24	0.45	350
1	F37-316/30-CFX*	26.2	52.4	60	71	69	64	75	24	0.39	350
1 1/4	F37-320-CFX	30.2	58.7	68	79	81	78	84	22	0.46	280
1 1/4	F37-320/38-CFX*	30.2	58.7	68	79	81	78	84	22	0.46	280
1 1/2	F37-324-CFX	35.7	69.9	78	93	93	87	99	25	0.68	280
1 1/2	F37-324/42-CFX*	35.7	69.9	78	93	93	87	99	25	0.75	280
2	F37-332-CFX	42.9	77.8	97	102	104	102	107	33	0.98	280
2 1/2	F37-340-CFX	50.8	88.9	109	116	117	114	120	44	1.63	210
3	F37-348-CFX	61.9	106.4	132	135	138	136	141	50	2.79	210

Parflange F37 threaded flange dimensions

*Jump size flanges (no adapter sleeves (SL...) necessary).

Size Inch	Flange Order code	A	B	G	H	M	N	O	L	Thread	Weight body (Steel) kg/1 piece	W.P. bar
1/2	F37-308T-CFX	17.5	38.1	46	54	55	51	59	19	M08	0.17	350
3/4	F37-312T-CFX	22.3	47.6	52	65	63	57	70	20	M10	0.25	350
1	F37-316T-CFX	26.2	52.4	60	71	69	64	75	24	M10	0.30	350
1	F37-316/30T-CFX*	26.2	52.4	60	71	69	64	75	24	M10	0.39	350
1 1/4	F37-320T-CFX	30.2	58.7	68	79	81	78	84	22	M10	0.46	280
1 1/4	F37-320/38T-CFX*	30.2	58.7	68	79	81	78	84	22	M10	0.46	280
1 1/2	F37-324T-CFX	35.7	69.9	78	93	93	87	99	25	M10	0.68	280
2	F37-332T-CFX	42.9	77.8	97	102	104	102	107	33	M12	0.98	280
2 1/2	F37-340T-CFX	50.8	88.9	109	116	117	114	120	44	M12	1.63	210
3	F37-348T-CFX	61.9	106.4	132	135	138	136	141	50	M16	2.87	210

Pressure rates related to flanges. Other sizes / jump sizes on request.

Please change suffixes according to material/surface required

Order code suffixes			
Material	Suffix surface and material	Example	Comments
Steel, zinc plated, Cr(VI)-free	CF	F37-320-CFX	
Stainless steel	SS	F37-320-SSX	
Galvanized hot dip zinc	TZN	F37-320-TZNX (Not for threaded flanges available)	on request

Parflange® F37 – SAE 3000/ISO 6162-1

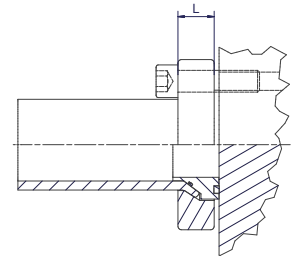
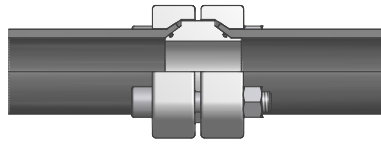

Part combination flaring SAE 3000

Flange Pressure (bar)	Size Inch	Pipe Size	Flange SAE 3000 ISO 6162-1	Insert*	Sleeve
350	1/2	16X2.0	F37-308-CFX	IN08-16X2.0T...	SL08-25-16-CFX**
	1/2	18X2.0	F37-308-CFX	IN08-18X2.0T...	SL08-25-18-CFX
	1/2	20X2.0	F37-308-CFX	IN08-20X2.0T...	SL08-25-20-CFX**
	1/2	20X2.5	F37-308-CFX	IN08-20X2.5T...	SL08-25-20-CFX**
	1/2	25X2.5	F37-308-CFX	IN08-25X2.5T...	
	1/2	25X3.0	F37-308-CFX	IN08-25X3.0T...	
	3/4	20X2.0	F37-312-CFX	IN12-20X2.0T...	SL12-30-20-CFX
	3/4	20X2.5	F37-312-CFX	IN12-20X2.5T...	SL12-30-20-CFX
	3/4	25X2.5	F37-312-CFX	IN12-25X2.5T...	SL12-30-25-CFX
	3/4	25X3.0	F37-312-CFX	IN12-25X3.0T...	SL12-30-25-CFX
	3/4	30X3.0	F37-312-CFX	IN12-30X3.0T...	
	3/4	30X4.0	F37-312-CFX	IN12-30X4.0T...	
	1	25X2.5	F37-316-CFX	IN16-25X2.5T...	SL16-38-25-CFX**
	1	25X3.0	F37-316-CFX	IN16-25X3.0T...	SL16-38-25-CFX**
	1	30X3.0	F37-316-CFX	IN16-30X3.0T...	SL16-38-30-CFX**
	1	30X4.0	F37-316-CFX	IN16-30X4.0T...	SL16-38-30-CFX**
	1	38X2.5	F37-316-CFX	IN16-38X2.5T...	
	1	38X3.0	F37-316-CFX	IN16-38X3.0T...	
1	38X4.0	F37-316-CFX	IN16-38X4.0T...		
1	38X5.0	F37-316-CFX	IN16-38X5.0T...		
280	1 1/4	30X3.0	F37-320-CFX	IN20-30X3.0T...	SL20-42-30-CFX
	1 1/4	30X4.0	F37-320-CFX	IN20-30X4.0T...	SL20-42-30-CFX
	1 1/4	38X3.0	F37-320-CFX	IN20-38X3.0T...	SL20-42-38-CFX**
	1 1/4	38X4.0	F37-320-CFX	IN20-38X4.0T...	SL20-42-38-CFX**
	1 1/4	38X5.0	F37-320-CFX	IN20-38X5.0T...	SL20-42-38-CFX**
	1 1/4	42X3.0	F37-320-CFX	IN20-42X3.0T...	
	1 1/4	42X4.0	F37-320-CFX	IN20-42X4.0T...	
	1 1/2	38X3.0	F37-324-CFX	IN24-38X3.0T...	SL24-50-38-CFX
	1 1/2	38X4.0	F37-324-CFX	IN24-38X4.0T...	SL24-50-38-CFX
	1 1/2	38X5.0	F37-324-CFX	IN24-38X5.0T...	SL24-50-38-CFX
	1 1/2	42X3.0	F37-324-CFX	IN24-42X3.0T...	SL24-50-42-CFX**
	1 1/2	42X4.0	F37-324-CFX	IN24-42X4.0T...	SL24-50-42-CFX**
	1 1/2	50X3.0	F37-324-CFX	IN24-50X3.0T...	
	1 1/2	50X5.0	F37-324-CFX	IN24-50X5.0T...	
	1 1/2	50X6.0	F37-324-CFX	IN24-50X6.0T...	
	2	50X3.0	F37-332-CFX	IN32-50X3.0T...	SL32-60-50-CFX
	2	50X5.0	F37-332-CFX	IN32-50X5.0T...	SL32-60-50-CFX
	2	50X6.0	F37-332-CFX	IN32-50X6.0T...	SL32-60-50-CFX
2	60X3.0	F37-332-CFX	IN32-60X3.0T...		
2	60X5.0	F37-332-CFX	IN32-60X5.0T...		
2	60X6.0	F37-332-CFX	IN32-60X6.0T...		
210	2 1/2	60X3.0	F37-340-CFX	IN40-60X3.0T...	SL40-75-60-CFX
	2 1/2	60X5.0	F37-340-CFX	IN40-60X5.0T...	SL40-75-60-CFX
	2 1/2	60X6.0	F37-340-CFX	IN40-60X6.0T...	SL40-75-60-CFX
	2 1/2	75X3.0	F37-340-CFX	IN40-75X3.0T...	
	2 1/2	75X5.0	F37-340-CFX	IN40-75X5.0T...	
	3	75X3.0	F37-348-CFX	IN48-75X3.0T...	SL48-90-75-CFX
	3	75X5.0	F37-348-CFX	IN48-75X5.0T...	SL48-90-75-CFX
	3	90X3.5	F37-348-CFX	IN48-90X3.5T...	
	3	90X5.0	F37-348-CFX	IN48-90X5.0T...	

Select the complete version: * ...FBCF Bonded Seal version ...FVCF F37 Seal version ...TCF Tube to Tube version ...FCF Flat Face version.

**Jump size flanges available alternatively to adapter sleeve, see page 63.

Other sizes like schedule on request.

Bolts and nuts are not included in complete part numbers. For recommended bolts and nuts see page 94.



R – Retaining ring flange | SAE 3000/ISO 6162-1 footprint

SAE 3000/ISO 6162-1

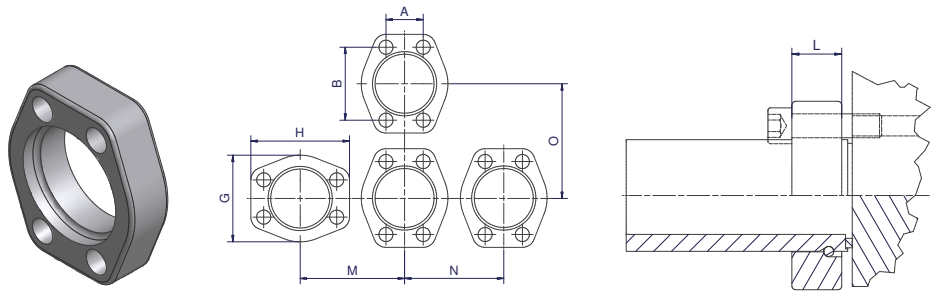

Retaining ring flange dimensions

Size Inch	Order Code	A	B	G	H	M	N	O	L	Weight body (Steel) kg/1 piece	W.P. bar
1/2	R-308-CFX	17.5	38.1	46	54	55	51	59	19	0.2	350
3/4	R-312-CFX	22.3	47.6	52	65	63	57	70	20	0.2	350
1	R-316-CFX	26.2	52.4	59	71	69	64	75	24	0.3	350
1 1/4	R-320-CFX	30.2	58.7	73	79	81	78	84	22	0.5	280
1 1/2	R-324-CFX	35.7	69.9	83	95	93	87	99	25	0.6	280
2	R-332-CFX	42.9	77.8	97	102	104	102	107	33	1.0	280
2 1/2	R-340-CFX	50.8	88.9	109	116	117	114	120	44	1.6	210
3	R-348-CFX	61.9	106.4	132	135	138	136	141	50	2.5	210

Pressure rates related to flanges.
Other sizes like schedule on request.
For all sizes also threaded flanges available (...T-CFX).

Please change suffixes according to material/surface required

Order code suffixes			
Material	Suffix surface and material	Example	Comments
Steel, zinc plated, Cr(VI)-free	CF	R-320-CFX	
Stainless steel	SS	R-320-SSX	
Galvanized hot dip zinc	TZN	R-320-TZNX	on request

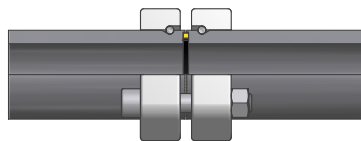

Part combination Bonded seal SAE 3000 connection

Flange pressure (bar)	Size Inch	Pipe Size	Flange	Retaining Ring	Bonded Seal
350	1/2	26X6.0	R-308-CFX	R08X	BS08SNX
	3/4	36X8.0	R-312-CFX	R12X	BS12SNX
	1	39X7.5	R-316-CFX	R16X	BS16SNX
280	1 1/4	46X8.0	R-320-CFX	R20X	BS20SNX
	1 1/2	56X8.5	R-324-CFX	R24X	BS24SNX
	2	66X8.5	R-332-CFX	R32X	BS32SNX
210	2 1/2	80x10.0	R-340-CFX	R40X	BS40SNX
	3	97X12.0	R-348-CFX	R48X	BS48SNX

Bolts and nuts are not included in complete part numbers For recommended bolts and nuts see page 94.

PSC – Pipe seal carrier | SAE 3000/ISO 6162-1 footprint

SAE 3000/ISO 6162-1

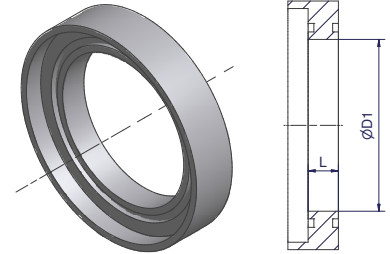

Size Inch	Pipe size	Seal carrier incl. F37 Seal	Seal carrier incl. O-Ring	L	D1	F37 Seal	O-Ring
1 1/4	46X3.0	PSC20-46X8.0VCF	PSC20-46X8.0OCF	8.0	30	F37RS20X	OR34.59X2.62X
1 1/2	56X8.5	PSC24-56X8.5VCF	PSC24-56X8.5OCF	10.0	39	F37RS24X	OR44.12X2.62X
2	66X8.5	PSC32-66X8.5VCF	PSC32-66X8.5OCF	10.0	49	F37RS32X	OR55.25X2.62X
2 1/2	80X10.0	PSC40-80X10VCF	PSC40-80X10OCF	15.0	60	F37RS40X	OR66.27X3.53X
3	97X12.0	PSC48-97X12VCF	PSC48-97X12OCF	15.0	73	F37RS48X	OR78.97X3.53X

Other sizes on request.

Please change suffixes according to material/surface required

Order code suffixes		
Material	Suffix surface and material	Example
Steel, zinc plated, Cr(VI)-free, F37-Seal	VCF	PSC40-80X10VCF
Stainless steel, F37-Seal	VSS	PSC40-80X10VSS
Steel, zinc plated, Cr(VI)-free, O-Ring (NBR)	OCF	PSC40-80X10OCF
Stainless steel, O-Ring (NBR)	OSS	PSC40-80X10OSS

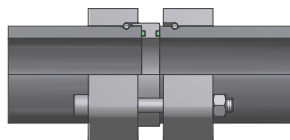

Example of part combinations Pipe seal carrier SAE 3000 connection

Flange pressure (bar)	Size Inch	Pipe Size	Flange	Retaining Ring	Pipe Seal Carrier
280	1 1/4	46X8.0	R-320-CFX	R20X	PSC20-45X8.0VCF
	1 1/2	56X8.5	R-324-CFX	R24X	PSC24-56X8.5VCF
	2	66X8.5	R-332-CFX	R32X	PSC32-66X8.5VCF
210	2 1/2	80X10.0	R-340-CFX	R40X	PSC40-80X10VCF
	3	97X12.0	R-348-CFX	R48X	PSC48-97X12VCF

Other sizes on request

Bolts and nuts are not included in complete part numbers. For recommended bolts and nuts see page 94.



TFB – Flare flange connection

Tube to port connection, bonded seal

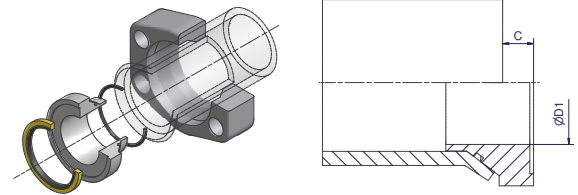

Size		Flange* incl. Insert + Bonded Seal + O-Ring Order code	D1	C	Insert incl.		O-Ring Order code	Weight (Steel) kg/1 kit
Inch	Tube				Bonded Seal + O-Ring Order code	Bonded Seal Order code		
1/2	16X2.0	F37-308-16X2.0TFBCF	9.5	8.0	IN08-16X2.0TFBCF	BS08SNX	OR12X1.0X	0.24
1/2	18X2.0	F37-308-18X2.0TFBCF	11.5	8.0	IN08-18X2.0TFBCF	BS08SNX	OR14X1.0X	0.24
1/2	20X2.0	F37-308-20X2.0TFBCF	13.5	8.0	IN08-20X2.0TFBCF	BS08SNX	OR16X1.0X	0.24
1/2	20X2.5	F37-308-20X2.5TFBCF	13.5	8.0	IN08-20X2.5TFBCF	BS08SNX	OR16X1.0X	0.24
1/2	25X2.5	F37-308-25X2.5TFBCF	13.5	10.0	IN08-25X2.5TFBCF	BS08SNX	OR20X1.0X	0.25
1/2	25X3.0	F37-308-25X3.0TFBCF	13.0	8.0	IN08-25X3.0TFBCF	BS08SNX	OR20X1.0X	0.24
3/4	20X2.0	F37-312-20X2.0TFBCF	13.5	8.0	IN12-20X2.0TFBCF	BS12SNX	OR16X1.0X	0.31
3/4	20X2.5	F37-312-20X2.5TFBCF	12.5	8.0	IN12-20X2.5TFBCF	BS12SNX	OR16X1.0X	0.31
3/4	25X2.5	F37-312-25X2.5TFBCF	17.5	10.0	IN12-25X2.5TFBCF	BS12SNX	OR20X1.0X	0.31
3/4	25X3.0	F37-312-25X3.0TFBCF	16.5	8.0	IN12-25X3.0TFBCF	BS12SNX	OR20X1.0X	0.32
3/4	30X3.0	F37-312-30X3.0TFBCF	19.0	8.5	IN12-30X3.0TFBCF	BS12SNX	OR25X1.0X	0.32
3/4	30X4.0	F37-312-30X4.0TFBCF	19.0	8.5	IN12-30X4.0TFBCF	BS12SNX	OR22X1.0X	1.32
1	25X2.5	F37-316-25X2.5TFBCF	17.5	10.0	IN16-25X2.5TFBCF	BS16SNX	OR20X1.0X	0.39
1	25X3.0	F37-316-25X3.0TFBCF	16.5	8.0	IN16-25X3.0TFBCF	BS16SNX	OR20X1.0X	0.39
1	30X3.0	F37-316-30X3.0TFBCF	21.5	8.5	IN16-30X3.0TFBCF	BS16SNX	OR25X1.0X	0.39
1	30X4.0	F37-316-30X4.0TFBCF	19.5	8.5	IN16-30X4.0TFBCF	BS16SNX	OR22X1.0X	0.39
1	38X2.5	F37-316-38X2.5TFBCF	25.0	9.5	IN16-38X2.5TFBCF	BS16SNX	OR34X1.0X	0.41
1	38X3.0	F37-316-38X3.0TFBCF	25.0	9.0	IN16-38X3.0TFBCF	BS16SNX	OR34X1.0X	0.40
1	38X4.0	F37-316-38X4.0TFBCF	25.0	10.0	IN16-38X4.0TFBCF	BS16SNX	OR30X1.0X	0.40
1	38X5.0	F37-316-38X5.0TFBCF	25.0	8.0	IN16-38X5.0TFBCF	BS16SNX	OR28X1.0X	0.39
1 1/4	30X3.0	F37-320-30X3.0TFBCF	21.5	8.5	IN20-30X3.0TFBCF	BS20SNX	OR25X1.0X	0.57
1 1/4	30X4.0	F37-320-30X4.0TFBCF	19.5	8.5	IN20-30X4.0TFBCF	BS20SNX	OR22X1.0X	0.58
1 1/4	38X3.0	F37-320-38X3.0TFBCF	29.5	9.0	IN20-38X3.0TFBCF	BS20SNX	OR34X1.0X	0.56
1 1/4	38X4.0	F37-320-38X4.0TFBCF	27.0	10.0	IN20-38X4.0TFBCF	BS20SNX	OR30X1.0X	0.57
1 1/4	38X5.0	F37-320-38X5.0TFBCF	25.5	8.0	IN20-38X5.0TFBCF	BS20SNX	OR28X1.0X	0.56
1 1/4	42X3.0	F37-320-42X3.0TFBCF	31.5	10.0	IN20-42X3.0TFBCF	BS20SNX	OR37.82X1.78X	0.57
1 1/4	42X4.0	F37-320-42X4.0TFBCF	31.5	10.0	IN20-42X4.0TFBCF	BS20SNX	OR34X1.0X	0.56
1 1/2	38x3.0	F37-324-38X3.0TFBCF	27.5	9.0	IN24-38X3.0TFBCF	BS20SNX	OR34X1.0X	0.65
1 1/2	38X4.0	F37-324-38X4.0TFBCF	27.5	10.0	IN24-38X4.0TFBCF	BS24SNX	OR30.X1.0X	0.87
1 1/2	38X5.0	F37-324-38X5.0TFBCF	25.0	11.0	IN24-38X5.0TFBCF	BS24SNX	OR28X1.0X	0.87
1 1/2	42X3.0	F37-324-42X3.0TFBCF	35.0	10.0	IN24-42X3.0TFBCF	BS24SNX	OR37.82X1.78X	0.88
1 1/2	42X4.0	F37-324-42X4.0TFBCF	31.5	10.0	IN24-42X4.0TFBCF	BS24SNX	OR34X1.0X	0.87
1 1/2	50X3.0	F37-324-50X3.0TFBCF	36.0	11.0	IN24-50X3.0TFBCF	BS24SNX	OR44.17X1.78X	0.87
1 1/2	50X5.0	F37-324-50X5.0TFBCF	36.0	10.0	IN24-50X5.0TFBCF	BS24SNX	OR41X1.78X	0.87
1 1/2	50X6.0	F37-324-50X6.0TFBCF	35.0	10.0	IN24-50X6.0TFBCF	BS24SNX	OR41X1.78X	0.87
2	50X3.0	F37-332-50X3.0TFBCF	41.5	11.0	IN32-50X3.0TFBCF	BS32SNX	OR44.17X1.78X	1.20
2	50X5.0	F37-332-50X5.0TFBCF	37.5	10.0	IN32-50X5.0TFBCF	BS32SNX	OR41X1.78X	1.22
2	50X6.0	F37-332-50X6.0TFBCF	35.0	10.0	IN32-50X6.0TFBCF	BS32SNX	OR41X1.78X	1.25
2	60X3.0	F37-332-60X3.0TFBCF	46.0	12.0	IN32-60X3.0TFBCF	BS32SNX	OR53.7X1.78X	1.25
2	60X5.0	F37-332-60X5.0TFBCF	46.0	11.0	IN32-60X5.0TFBCF	BS32SNX	OR50.52X1.78X	1.22
2	60X6.0	F37-332-60X6.0TFBCF	45.5	11.0	IN32-60X6.0TFBCF	BS32SNX	OR47.37X1.78X	1.21
2 1/2	60X3.0	F37-340-60X3.0TFBCF	50.0	12.0	IN40-60X3.0TFBCF	BS40SNX	OR53.7X1.78X	1.98
2 1/2	60X5.0	F37-340-60X5.0TFBCF	46.0	11.0	IN40-60X5.0TFBCF	BS40SNX	OR50.52X1.78X	1.99
2 1/2	60X6.0	F37-340-60X6.0TFBCF	45.5	11.0	IN40-60X6.0TFBCF	BS40SNX	OR47.37X1.78X	1.97
2 1/2	75X3.0	F37-340-75X3.0TFBCF	60.0	10.0	IN40-75X3.0TFBCF	BS40SNX	OR69.57X1.78X	1.93
2 1/2	75X5.0	F37-340-75X5.0TFBCF	60.0	10.0	IN40-75X5.0TFBCF	BS40SNX	OR63.22X1.78X	1.95
3	75X3.0	F37-348-75X3.0TFBCF	66.0	10.0	IN48-75X3.0TFBCF	BS48SNX	OR69.57X1.78X	3.22
3	75X5.0	F37-348-75X5.0TFBCF	62.0	10.0	IN48-75X5.0TFBCF	BS48SNX	OR63.22X1.78X	3.38
3	90X3.5	F37-348-90X3.5TFBCF	72.0	15.0	IN48-90X3.5TFBCF	BS48SNX	OR82.27X1.78X	3.39
3	90X5.0	F37-348-90X5.0TFBCF	72.0	14.0	IN48-90X5.0TFBCF	BS48SNX	OR79X1.78X	3.35

Other sizes on request. *Incl. adapter sleeve or jump size flange if necessary.

Please change suffixes according to material/surface required

Order code suffixes		
Material	Suffix surface and material	Example
Steel, zinc plated, Cr(VI)-free	CF	F37-324-50X5.0TFBCF
Stainless steel	SS	F37-324-50X5.0TFBSS

TFV – Flare flange connection

Tube to port connection, F37 seal

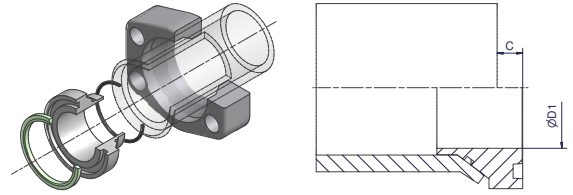

Size		Flange* incl. Insert + F37 Seal + O-Ring Order code	D1	C	Insert incl. F37 Seal + O-Ring Order code	F37 Seal Order code	O-Ring Order code	Weight (Steel) kg/1 kit
Inch	Tube							
1/2	16X2.0	F37-308-16X2.0TFVCF	9.5	8.0	IN08-16X2.0TFVCF	F37S08X	OR12X1.0X	0.24
1/2	18X2.0	F37-308-18X2.0TFVCF	11.5	8.0	IN08-18X2.0TFVCF	F37S08X	OR14X1.0X	0.24
1/2	20X2.0	F37-308-20X2.0TFVCF	13.5	8.0	IN08-20X2.0TFVCF	F37S08X	OR16X1.0X	0.24
1/2	20X2.5	F37-308-20X2.5TFVCF	13.5	8.0	IN08-20X2.5TFVCF	F37S08X	OR16X1.0X	0.24
1/2	25X2.5	F37-308-25X2.5TFVCF	13.5	10.0	IN08-25X2.5TFVCF	F37S08X	OR20X1.0X	0.25
1/2	25X3.0	F37-308-25X3.0TFVCF	13.0	8.0	IN08-25X3.0TFVCF	F37S08X	OR20X1.0X	0.24
3/4	20X2.0	F37-312-20X2.0TFVCF	13.5	8.0	IN12-20X2.0TFVCF	F37S12X	OR16X1.0X	0.31
3/4	20X2.5	F37-312-20X2.5TFVCF	12.5	8.0	IN12-20X2.5TFVCF	F37S12X	OR16X1.0X	0.31
3/4	25X2.5	F37-312-25X2.5TFVCF	17.5	10.0	IN12-25X2.5TFVCF	F37S12X	OR20X1.0X	0.31
3/4	25X3.0	F37-312-25X3.0TFVCF	16.5	8.0	IN12-25X3.0TFVCF	F37S12X	OR20X1.0X	0.32
3/4	30X3.0	F37-312-30X3.0TFVCF	19.0	8.5	IN12-30X3.0TFVCF	F37S12X	OR25X1.0X	0.32
3/4	30X4.0	F37-312-30X4.0TFVCF	19.0	8.5	IN12-30X4.0TFVCF	F37S12X	OR22X1.0X	0.32
1	25X2.5	F37-316-25X2.5TFVCF	17.5	10.0	IN16-25X2.5TFVCF	F37S16X	OR20X1.0X	0.38
1	25X3.0	F37-316-25X3.0TFVCF	16.5	8.0	IN16-25X3.0TFVCF	F37S16X	OR20X1.0X	0.39
1	30X3.0	F37-316-30X3.0TFVCF	21.5	8.5	IN16-30X3.0TFVCF	F37S16X	OR25X1.0X	0.41
1	30X4.0	F37-316-30X4.0TFVCF	19.5	8.5	IN16-30X4.0TFVCF	F37S16X	OR22X1.0X	0.39
1	38X2.5	F37-316-38X2.5TFVCF	25.0	9.5	IN16-38X2.5TFVCF	F37S16X	OR34X1.0X	0.41
1	38X3.0	F37-316-38X3.0TFVCF	25.0	9.0	IN16-38X3.0TFVCF	F37S16X	OR34X1.0X	0.40
1	38X4.0	F37-316-38X4.0TFVCF	25.0	10.0	IN16-38X4.0TFVCF	F37S16X	OR30X1.0X	0.40
1	38X5.0	F37-316-38X5.0TFVCF	25.0	8.0	IN16-38X5.0TFVCF	F37S16X	OR28X1.0X	0.39
1 1/4	30X3.0	F37-320-30X3.0TFVCF	21.5	8.5	IN20-30X3.0TFVCF	F37S20X	OR25X1.0X	0.57
1 1/4	30X4.0	F37-320-30X4.0TFVCF	19.5	8.5	IN20-30X4.0TFVCF	F37S20X	OR22X1.0X	0.58
1 1/4	38X3.0	F37-320-38X3.0TFVCF	29.5	9.0	IN20-38X3.0TFVCF	F37S20X	OR34X1.0X	0.56
1 1/4	38X4.0	F37-320-38X4.0TFVCF	27.0	10.0	IN20-38X4.0TFVCF	F37S20X	OR30X1.0X	0.57
1 1/4	38X5.0	F37-320-38X5.0TFVCF	25.5	8.0	IN20-38X5.0TFVCF	F37S20X	OR28X1.0X	0.56
1 1/4	42X3.0	F37-320-42X3.0TFVCF	31.5	10.0	IN20-42X3.0TFVCF	F37S20X	OR37.82X1.78X	0.57
1 1/4	42X4.0	F37-320-42X4.0TFVCF	31.5	10.0	IN20-42X4.0TFVCF	F37S20X	OR34X1.0X	0.56
1 1/2	38X3.0	F37-324-38X3.0TFVCF	27.5	9.0	IN24-38X3.0TFVCF	F37S24X	OR34X1.0X	0.87
1 1/2	38X4.0	F37-324-38X4.0TFVCF	27.5	10.0	IN24-38X4.0TFVCF	F37S24X	OR30X1.0X	0.87
1 1/2	38X5.0	F37-324-38X5.0TFVCF	25.0	11.0	IN24-38X5.0TFVCF	F37S24X	OR41X1.78X	0.87
1 1/2	42X3.0	F37-324-42X3.0TFVCF	33.5	10.0	IN24-42X3.0TFVCF	F37S24X	OR37.82X1.78X	0.87
1 1/2	42X4.0	F37-324-42X4.0TFVCF	31.5	10.0	IN24-42X4.0TFVCF	F37S24X	OR34X1.0X	0.87
1 1/2	50X3.0	F37-324-50X3.0TFVCF	36.0	11.0	IN24-50X3.0TFVCF	F37S24X	OR44.17X1.78X	0.87
1 1/2	50X5.0	F37-324-50X5.0TFVCF	36.0	10.0	IN24-50X5.0TFVCF	F37S24X	OR41X1.78X	0.87
1 1/2	50X6.0	F37-324-50X6.0TFVCF	35.0	10.0	IN24-50X6.0TFVCF	F37S24X	OR41X1.78X	0.87
2	50X3.0	F37-332-50X3.0TFVCF	41.5	11.0	IN32-50X3.0TFVCF	F37S32X	OR44.17X1.78X	1.20
2	50X5.0	F37-332-50X5.0TFVCF	37.5	10.0	IN32-50X5.0TFVCF	F37S32X	OR41X1.78X	1.22
2	50X6.0	F37-332-50X6.0TFVCF	35.0	10.0	IN32-50X6.0TFVCF	F37S32X	OR41X1.78X	1.25
2	60X3.0	F37-332-60X3.0TFVCF	46.0	12.0	IN32-60X3.0TFVCF	F37S32X	OR53.7X1.78X	1.25
2	60X5.0	F37-332-60X5.0TFVCF	46.0	11.0	IN32-60X5.0TFVCF	F37S32X	OR50.52X1.78X	1.22
2	60X6.0	F37-332-60X6.0TFVCF	45.5	11.0	IN32-60X6.0TFVCF	F37S32X	OR47.37X1.78X	1.21
2 1/2	60X3.0	F37-340-60X3.0TFVCF	50.0	12.0	IN40-60X3.0TFVCF	F37S40X	OR53.7X1.78X	1.98
2 1/2	60X5.0	F37-340-60X5.0TFVCF	46.0	11.0	IN40-60X5.0TFVCF	F37S40X	OR50.52X1.78X	1.99
2 1/2	60X6.0	F37-340-60X6.0TFVCF	45.5	11.0	IN40-60X6.0TFVCF	F37S40X	OR47.37X1.78X	1.97
2 1/2	75X3.0	F37-340-75X3.0TFVCF	60.0	10.0	IN40-75X3.0TFVCF	F37S40X	OR69.57X1.78X	1.93
2 1/2	75X5.0	F37-340-75X5.0TFVCF	60.0	10.0	IN40-75X5.0TFVCF	F37S40X	OR63.22X1.78X	1.95
3	75X3.0	F37-348-75X3.0TFVCF	66.0	10.0	IN48-75X3.0TFVCF	F37S48X	OR69.57X1.78X	3.22
3	75X5.0	F37-348-75X5.0TFVCF	62.0	10.0	IN48-75X5.0TFVCF	F37S48X	OR63.22X1.78X	3.38
3	90X3.5	F37-348-90X3.5TFVCF	72.0	15.0	IN48-90X3.5TFVCF	F37S48X	OR82.27X1.78X	3.39
3	90X5.0	F37-348-90X5.0TFVCF	72.0	14.0	IN48-90X5.0TFVCF	F37S48X	OR79X1.78X	3.35

Other sizes on request. *Incl. adapter sleeve or jump size flange if necessary.

Please change suffixes according to material/surface required

Order code suffixes		
Material	Suffix surface and material	Example
Steel, zinc plated, Cr(VI)-free	CF	F37-324-50X5.0TFVCF
Stainless steel	SS	F37-324-50X5.0TFVSS



TT - Flare flange connection

Tube to tube connection

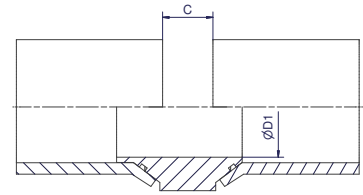
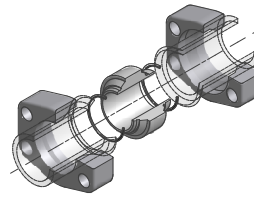

Size		2 Flanges* incl. Insert + 2 x O-Ring Order code	D1	C	Insert incl. 2 x O-Ring Order code	O-Ring Order code	Weight (Steel) kg/1 kit
Inch	Tube						
1/2	16X2.0	F37-308-16X2.0TTCF	9.5	16	IN08-16X2.0TTCF	OR12X1.0X	0.28
1/2	18X2.0	F37-308-18X2.0TTCF	11.5	16	IN08-18X2.0TTCF	OR14X1.0X	0.29
1/2	20X2.0	F37-308-20X2.0TTCF	13.5	16	IN08-20X2.0TTCF	OR16X1.0X	0.29
1/2	20X2.5	F37-308-20X2.5TTCF	13.5	16	IN08-20X2.5TTCF	OR16X1.0X	0.29
1/2	25X2.5	F37-308-25X2.5TTCF	13.5	20	IN08-25X2.5TTCF	OR20X1.0X	0.30
1/2	25X3.0	F37-308-25X3.0TTCF	13.0	16	IN08-25X3.0TTCF	OR20X1.0X	0.29
3/4	20X2.0	F37-312-20X2.0TTCF	13.5	16	IN12-20X2.0TTCF	OR16X1.0X	0.38
3/4	20X2.5	F37-312-20X2.5TTCF	12.5	16	IN12-20X2.5TTCF	OR16X1.0X	0.38
3/4	25X2.5	F37-312-25X2.5TTCF	17.5	20	IN12-25X2.5TTCF	OR20X1.0X	0.39
3/4	25X3.0	F37-312-25X3.0TTCF	16.5	16	IN12-25X3.0TTCF	OR20X1.0X	0.39
3/4	30X3.0	F37-312-30X3.0TTCF	19.0	17	IN12-30X3.0TTCF	OR25X1.0X	0.40
3/4	30X4.0	F37-312-30X4.0TTCF	19.0	17	IN12-30X4.0TTCF	OR22X1.0X	0.40
1	25X2.5	F37-316-25X2.5TTCF	17.5	20	IN16-25X2.5TTCF	OR20X1.0X	0.49
1	25X3.0	F37-316-25X3.0TTCF	16.5	16	IN16-25X3.0TTCF	OR20X1.0X	0.49
1	30X3.0	F37-316-30X3.0TTCF	21.5	17	IN16-30X3.0TTCF	OR25X1.0X	0.48
1	30X4.0	F37-316-30X4.0TTCF	19.5	17	IN16-30X4.0TTCF	OR22X1.0X	0.49
1	38X2.5	F37-316-38X2.5TTCF	25.0	19	IN16-38X2.5TTCF	OR34X1.0X	0.54
1	38X3.0	F37-316-38X3.0TTCF	25.0	18	IN16-38X3.0TTCF	OR34X1.0X	0.52
1	38X4.0	F37-316-38X4.0TTCF	25.0	20	IN16-38X4.0TTCF	OR30X1.0X	0.50
1	38X5.0	F37-316-38X5.0TTCF	25.0	16	IN16-38X5.0TTCF	OR28X1.0X	0.48
1 1/4	30X3.0	F37-320-30X3.0TTCF	21.5	17	IN20-30X3.0TTCF	OR25X1.0X	0.70
1 1/4	30X4.0	F37-320-30X4.0TTCF	19.5	17	IN20-30X4.0TTCF	OR22X1.0X	0.73
1 1/4	38X3.0	F37-320-38X3.0TTCF	29.0	18	IN20-38X3.0TTCF	OR34X1.0X	0.68
1 1/4	38X4.0	F37-320-38X4.0TTCF	27.0	20	IN20-38X4.0TTCF	OR30X1.0X	0.69
1 1/4	38X5.0	F37-320-38X5.0TTCF	25.5	16	IN20-38X5.0TTCF	OR28X1.0X	0.67
1 1/4	42X3.0	F37-320-42X3.0TTCF	31.5	20	IN20-42X3.0TTCF	OR37.82X1.78X	0.68
1 1/4	42X4.0	F37-320-42X4.0TTCF	31.5	20	IN20-42X4.0TTCF	OR34X1.0X	0.67
1 1/2	38X3.0	F37-324-38X3.0TTCF	27.5	18	IN24-38X3.0TTCF	OR34X1.0X	0.93
1 1/2	38X4.0	F37-324-38X4.0TTCF	27.5	20	IN24-38X4.0TTCF	OR30.X1.0X	0.93
1 1/2	38X5.0	F37-324-38X5.0TTCF	25.0	22	IN24-38X5.0TTCF	OR41X1.78X	0.93
1 1/2	42X3.0	F37-324-42X3.0TTCF	33.5	20	IN24-42X3.0TTCF	OR37.82X1.78X	0.98
1 1/2	42X4.0	F37-324-42X4.0TTCF	31.5	20	IN24-42X4.0TTCF	OR34X1.0X	1.08
1 1/2	50X3.0	F37-324-50X3.0TTCF	36.0	22	IN24-50X3.0TTCF	OR44.17X1.78X	1.10
1 1/2	50X5.0	F37-324-50X5.0TTCF	36.0	20	IN24-50X5.0TTCF	OR41X1.78X	1.21
1 1/2	50X6.0	F37-324-50X6.0TTCF	35.0	20	IN24-50X6.0TTCF	OR41X1.78X	1.10
2	50X3.0	F37-332-50X3.0TTCF	41.5	22	IN32-50X3.0TTCF	OR44.17X1.78X	1.40
2	50X5.0	F37-332-50X5.0TTCF	37.5	20	IN32-50X5.0TTCF	OR41X1.78X	1.51
2	50X6.0	F37-332-50X6.0TTCF	35.0	20	IN32-50X6.0TTCF	OR41X1.78X	1.56
2	60X3.0	F37-332-60X3.0TTCF	46.0	24	IN32-60X3.0TTCF	OR53.7X1.78X	1.53
2	60X5.0	F37-332-60X5.0TTCF	46.0	22	IN32-60X5.0TTCF	OR50.52X1.78X	1.46
2	60X6.0	F37-332-60X6.0TTCF	45.5	22	IN32-60X6.0TTCF	OR47.37X1.78X	1.45
2 1/2	60X3.0	F37-340-60X3.0TTCF	50.0	24	IN40-60X3.0TTCF	OR53.7X1.78X	1.98
2 1/2	60X5.0	F37-340-60X5.0TTCF	46.0	22	IN40-60X5.0TTCF	OR50.52X1.78X	1.99
2 1/2	60X6.0	F37-340-60X6.0TTCF	45.0	22	IN40-60X6.0TTCF	OR47.37X1.78X	1.97
2 1/2	75X3.0	F37-340-75X3.0TTCF	60.0	20	IN40-75X3.0TTCF	OR69.57X1.78X	1.93
2 1/2	75X5.0	F37-340-75X5.0TTCF	60.0	20	IN40-75X5.0TTCF	OR63.22X1.78X	1.95
3	75X3.0	F37-348-75X3.0TTCF	66.0	20	IN48-75X3.0TTCF	OR69.57X1.78X	3.22
3	75X5.0	F37-348-75X5.0TTCF	62.0	20	IN48-75X5.0TTCF	OR63.22X1.78X	3.38
3	90X3.5	F37-348-90X3.5TTCF	72.0	30	IN48-90X3.5TTCF	OR82.27X1.78X	3.39
3	90X5.0	F37-348-90X5.0TTCF	72.0	28	IN48-90X5.0TTCF	OR79X1.78X	3.35

Other sizes on request. *Incl. adapter sleeve or jump size flange if necessary.

Please change suffixes according to material/surface required

Order code suffixes		
Material	Suffix surface and material	Example
Steel, zinc plated, Cr(VI)-free	CF	F37-324-50X5.0TTCF
Stainless steel	SS	F37-324-50X5.0TTSS

TF – Flare flange connection

Tube to flange connection, flat face

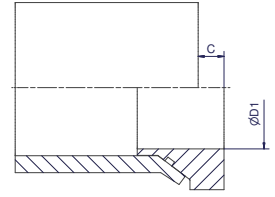
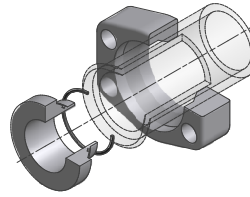

Size		Flange* incl. Insert + O-Ring Order code	D1	C	Insert incl. O-Ring Order code	O-Ring Order code	Weight (Steel) kg/1 kit
Inch	Tube						
1/2	16X2.0	F37-308-16X2.0TFCF	9.5	8.0	IN08-16X2.0TFCF	OR12X1.0X	0.24
1/2	18X2.0	F37-308-18X2.0TFCF	11.5	8.0	IN08-18X2.0TFCF	OR14X1.0X	0.24
1/2	20X2.0	F37-308-20X2.0TFCF	13.5	8.0	IN08-20X2.0TFCF	OR16X1.0X	0.25
1/2	20X2.5	F37-308-20X2.5TFCF	13.5	8.0	IN08-20X2.5TFCF	OR16X1.0X	0.25
1/2	25X2.5	F37-308-25X2.5TFCF	13.5	10.0	IN08-25X2.5TFCF	OR20X1.0X	0.25
1/2	25X3.0	F37-308-25X3.0TFCF	13.0	8.0	IN08-25X3.0TFCF	OR20X1.0X	0.24
3/4	20X2.0	F37-312-20X2.0TFCF	13.5	8.0	IN12-20X2.0TFCF	OR16X1.0X	0.31
3/4	20X2.5	F37-312-20X2.5TFCF	12.5	8.0	IN12-20X2.5TFCF	OR16X1.0X	0.31
3/4	25X2.5	F37-312-25X2.5TFCF	17.5	10.0	IN12-25X2.5TFCF	OR20X1.0X	0.31
3/4	25X3.0	F37-312-25X3.0TFCF	16.5	8.0	IN12-25X3.0TFCF	OR20X1.0X	0.32
3/4	30X3.0	F37-312-30X3.0TFCF	19.0	8.5	IN12-30X3.0TFCF	OR25X1.0X	0.32
3/4	30X4.0	F37-312-30x4.0TFCF	19.0	8.5	IN12-30x4.0TFCF	OR22X1.0X	0.32
1	25X2.5	F37-316-25X2.5TFCF	17.5	10.0	IN16-25X2.5TFCF	OR20X1.0X	0.38
1	25X3.0	F37-316-25X3.0TFCF	16.5	8.0	IN16-25X3.0TFCF	OR20X1.0X	0.39
1	30X3.0	F37-316-30X3.0TFCF	21.5	8.5	IN16-30X3.0TFCF	OR25X1.0X	0.41
1	30X4.0	F37-316-30X4.0TFCF	19.5	8.5	IN16-30X4.0TFCF	OR22X1.0X	0.39
1	38X2.5	F37-316-38X2.5TFCF	25.0	9.5	IN16-38X2.5TFCF	OR34X1.0X	0.41
1	38X3.0	F37-316-38X3.0TFCF	25.0	9.0	IN16-38X3.0TFCF	OR34X1.0X	0.40
1	38X4.0	F37-316-38X4.0TFCF	25.0	10.0	IN16-38X4.0TFCF	OR30X1.0X	0.40
1	38X5.0	F37-316-38X5.0TFCF	25.0	8.0	IN16-38X5.0TFCF	OR28X1.0X	0.39
1 1/4	30X3.0	F37-320-30X3.0TFCF	21.5	8.5	IN20-30X3.0TFCF	OR25X1.0X	0.57
1 1/4	30X4.0	F37-320-30X4.0TFCF	19.5	8.5	IN20-30X4.0TFCF	OR22X1.0X	0.59
1 1/4	38X3.0	F37-320-38X3.0TFCF	29.0	9.0	IN20-38X3.0TFCF	OR34X1.0X	0.56
1 1/4	38X4.0	F37-320-38X4.0TFCF	27.0	10.0	IN20-38X4.0TFCF	OR30X1.0X	0.57
1 1/4	38X5.0	F37-320-38X5.0TFCF	25.5	8.0	IN20-38X5.0TFCF	OR28X1.0X	0.56
1 1/4	42X3.0	F37-320-42X3.0TFCF	31.5	10.0	IN20-42X3.0TFCF	OR37.82X1.78X	0.57
1 1/4	42X4.0	F37-320-42X4.0TFCF	31.5	10.0	IN20-42X4.0TFCF	OR34X1.0X	0.56
1 1/2	38X3.0	F37-324-38X3.0TFCF	27.5	9.0	IN24-38X3.0TFCF	OR34X1.0X	0.87
1 1/2	38X4.0	F37-324-38X4.0TFCF	27.5	10.0	IN24-38X4.0TFCF	OR30X1.0X	0.87
1 1/2	38X5.0	F37-324-38X5.0TFCF	25.0	11.0	IN24-38X5.0TFCF	OR41X1.78X	0.87
1 1/2	42X3.0	F37-324-42X3.0TFCF	33.5	10.0	IN24-42X3.0TFCF	OR37.82X1.78X	0.87
1 1/2	42X4.0	F37-324-42X4.0TFCF	31.5	10.0	IN24-42X4.0TFCF	OR34X1.0X	0.87
1 1/2	50X3.0	F37-324-50X3.0TFCF	36.0	11.0	IN24-50X3.0TFCF	OR44.17X1.78X	0.87
1 1/2	50X5.0	F37-324-50X5.0TFCF	36.0	10.0	IN24-50X5.0TFCF	OR41X1.78X	0.87
1 1/2	50X6.0	F37-324-50X6.0TFCF	35.0	10.0	IN24-50X6.0TFCF	OR41X1.78X	0.87
2	50X3.0	F37-332-50X3.0TFCF	41.5	11.0	IN32-50X3.0TFCF	OR44.17X1.78X	1.20
2	50X5.0	F37-332-50X5.0TFCF	37.5	10.0	IN32-50X5.0TFCF	OR41X1.78X	1.22
2	50X6.0	F37-332-50X6.0TFCF	35.0	10.0	IN32-50X6.0TFCF	OR41X1.78X	1.25
2	60X3.0	F37-332-60X3.0TFCF	46.0	12.0	IN32-60X3.0TFCF	OR53.7X1.78X	1.25
2	60X5.0	F37-332-60X5.0TFCF	46.0	11.0	IN32-60X5.0TFCF	OR50.52X1.78X	1.22
2	60X6.0	F37-332-60X6.0TFCF	45.5	11.0	IN32-60X6.0TFCF	OR47.37X1.78X	1.21
2 1/2	60X3.0	F37-340-60X3.0TFCF	50.0	12.0	IN40-60X3.0TFCF	OR53.7X1.78X	1.98
2 1/2	60X5.0	F37-340-60X5.0TFCF	46.0	11.0	IN40-60X5.0TFCF	OR50.52X1.78X	1.99
2 1/2	60X6.0	F37-340-60X6.0TFCF	45.5	11.0	IN40-60X6.0TFCF	OR47.37X1.78X	1.97
2 1/2	75X3.0	F37-340-75X3.0TFCF	60.0	10.0	IN40-75X3.0TFCF	OR69.57X1.78X	1.93
2 1/2	75X5.0	F37-340-75X5.0TFCF	60.0	10.0	IN40-75X5.0TFCF	OR63.22X1.78X	1.95
3	75X3.0	F37-348-75X3.0TFCF	66.0	10.0	IN48-75X3.0TFCF	OR69.57X1.78X	3.22
3	75X5.0	F37-348-75X5.0TFCF	62.0	10.0	IN48-75X5.0TFCF	OR63.22X1.78X	3.38
3	90X3.5	F37-348-90X3.5TFCF	72.0	15.0	IN48-90X3.5TFCF	OR82.27X1.78X	3.39
3	90X5.0	F37-348-90X5.0TFCF	72.0	14.0	IN48-90X5.0TFCF	OR79X1.78X	3.35

Other sizes on request. *Incl. adapter sleeve or jump size flange if necessary.

Please change suffixes according to material/surface required

Order code suffixes		
Material	Suffix surface and material	Example
Steel, zinc plated, Cr(VI)-free	CF	F37-324-50X5.0TFCF
Stainless steel	SS	F37-324-50X5.0TFSS



SL – Sleeve

SAE 3000/ISO 6162-1

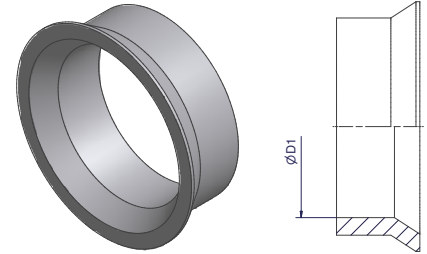

Size Inch	Tube OD	Order code	D1	Weight body (Steel) kg/1 piece
1/2	16	SL08-25-16-CFX*	16.30	0.04
1/2	18	SL08-25-18-CFX	18.30	0.04
1/2	20	SL08-25-20-CFX*	20.30	0.04
3/4	20	SL12-30-20-CFX	20.30	0.04
3/4	25	SL12-30-25-CFX	25.20	0.04
1	25	SL16-38-25-CFX*	25.20	0.04
1	30	SL16-38-30-CFX*	30.20	0.04
1 1/4	30	SL20-42-30-CFX	30.20	0.04
1 1/4	38	SL20-42-38-CFX*	38.25	0.04
1 1/2	38	SL24-50-38-CFX	38.25	0.14
1 1/2	42	SL24-50-42-CFX*	42.30	0.10
2	50	SL32-60-50-CFX	50.30	0.16
2 1/2	60	SL40-75-60-CFX	60.45	0.36
3	75	SL48-90-75-CFX	75.45	0.52

*By use of jump size flanges, no adapter sleeves necessary. For jump size flanges see page 61.

Please change suffixes according to material/surface required

Order code suffixes		
Material	Suffix surface and material	Example
Steel, zinc plated, Cr(VI)-free	CF	SL24-50-42-CFX
Stainless steel	SS	SL24-50-42-SSX

R – Retaining ring

SAE 3000/ISO 6162-1

Size Inch	Tube	Order code	D	S
1/2	26X6.0	R08X	22.3	4.0
3/4	36X8.0	R12X	32.3	4.0
1	39X7.5	R16X	34.3	5.0
1 1/4	46X8.0	R20X	41.3	5.0
1 1/2	56X8.5	R24X	51.3	5.0
2	66X8.5	R32X	61.3	5.0
2 1/2	80X10.0	R40X	75.3	5.0
3	97X12.0	R48X	91.3	6.0

Material: Stainless steel

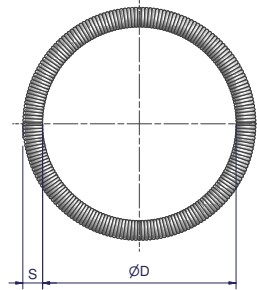

MTF-R – Male thread adapter, BSPP

SAE 3000/ISO 6162-1

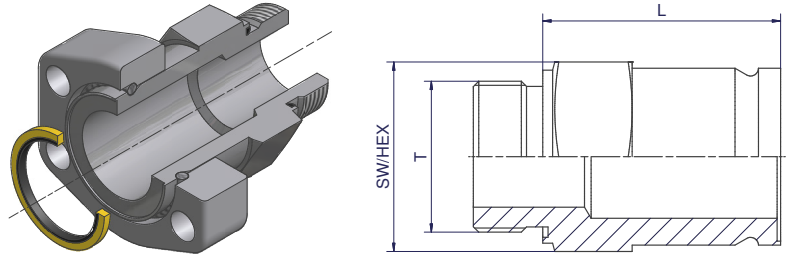

Size Inch	Tube	Complete part Order code	Body incl. ED Seal Order code	L	T (BSPP)	SW/ HEX	Weight body (Steel) kg/1 piece
1/2	26X6.0	R-308MTFRCF	MTF08ROMDCF	61.0	G 1/2A	27	0.21
3/4	36X8.0	R-312MTFRCF	MTF12ROMDCF	61.0	G 3/4A	36	0.32
3/4	36X8.0	R-312MTFR1/2CF	MTF12R1/2OMDCF	61.0	G 1/2A	36	0.32
1	39X7.5	R-316MTFRCF	MTF16ROMDCF	69.0	G 1A	41	0.50
1	39X7.5	R-316MTFR3/4CF	MTF16R3/4OMDCF	69.0	G 3/4A	41	0.50
1 1/4	46X8.0	R-320MTFRCF	MTF20ROMDCF	80.0	G 1 1/4A	50	0.75
1 1/4	46X8.0	R-320MTFR1CF	MTF20R1OMDCF	80.0	G 1A	50	0.73
1 1/2	56X8.5	R-324MTFRCF	MTF24ROMDCF	93.0	G 1 1/2A	60	1.20
1 1/2	56X8.5	R-324MTFR11/4CF	MTF24R11/4OMDCF	93.0	G 1 1/4A	60	1.17
2	66X8.5	R-332MTFRCF	MTF32ROMDCF	104.0	G 2A	75	1.87
2	66X8.5	R-332MTFR11/2CF	MTF32R11/2OMDCF	103.5	G 1 1/2A	75	1.80
2 1/2	80X10.0	R-340MTFRCF	MTF40ROMDCF	134.0	G 2 1/2A	85	3.50
2 1/2	80X10.0	R-340MTFR2CF	MTF40R2OMDCF	136.0	G 2A	85	3.50
3	97X12.0	R-348MTFRCF	MTF48ROMDCF	145.0	G 3A	95	5.00

Other sizes on request.

Please change suffixes according to material/surface required

Order code suffixes		
Material	Suffix surface and material	Example
Steel, zinc plated, Cr(VI)-free	CF	R-320MTFRCF
Stainless steel	SS	R-320MTFRSS

MTF-N – Male thread adapter, NPT

SAE 3000/ISO 6162-1

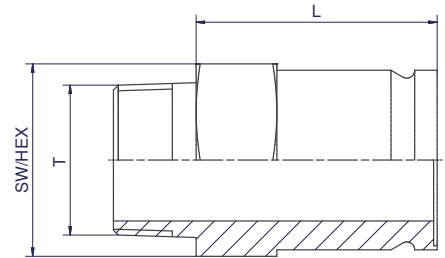
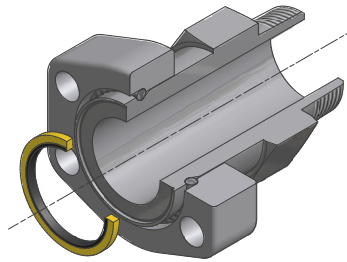

Size Inch	Tube	Complete part Order code	Body Order code	L	T (NPT)	SW/HEX	Weight body (Steel) kg/1 piece
1/2	26X6.0	R-308MTFNCF	MTF08NCFX	92.0	1/2-14	27	0.26
3/4	36X8.0	R-312MTFNCF	MTF12NCFX	72.6	3/4-14	36	0.48
1	39X7.5	R-316MTFNCF	MTF16NCFX	67.7	1-11.5	41	0.55
1 1/4	46X8.0	R-320MTFNCF	MTF20NCFX	75.0	1 1/4-11.5	50	0.70
1 1/2	56X8.5	R-324MTFNCF	MTF24NCFX	93.2	1 1/2-11.5	60	1.80
2	66X8.5	R-332MTFNCF	MTF32NCFX	100.4	2-11.5	75	2.40
2 1/2	80X10.0	R-340MTFNCF	MTF40NCFX	130.0	2 1/2-8	85	3.40
3	97X12.0	R-348MTFNCF	MTF48NCFX	141.2	3-8	95	4.90

Other sizes on request.

Please change suffixes according to material/surface required

Order code suffixes		
Material	Suffix surface and material	Example
Steel, zinc plated, Cr(VI)-free	CF	R-320MTFNCF
Stainless steel	SS	R-320MTFNSS



FTF-R – Female thread adapter, BSPP

SAE 3000/ISO 6162-1

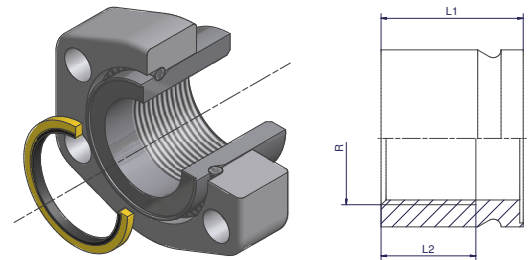

Size Inch	Tube	Complete part Order code	Body Order code	L1	L2	R (BSPP)	Weight body (Steel) kg/1 piece
1/2	26X6.0	R-308FTFRCF	FTF08RCFX	35	25	G 1/4	0.11
3/4	36X8.0	R-312FTFRCF	FTF12RCFX	40	25	G 1/2	0.22
1	39X7.5	R-316FTFRCF	FTF16RCFX	40	25	G 3/4	0.20
1 1/4	46X8.0	R-320FTFRCF	FTF20RCFX	42	30	G 1	0.30
1 1/2	56X8.5	R-324FTFRCF	FTF24RCFX	45	30	G 1 1/4	0.45
2	66X8.5	R-332FTFRCF	FTF32RCFX	55	40	G 1 1/2	0.75
2 1/2	80X10.0	R-340FTFRCF	FTF40RCFX	80	40	G 2	1.52
3	97X12.0	R-348FTFRCF	FTF48RCFX	85	50	G 2 1/2	2.11

Other sizes on request.

Please change suffixes according to material/surface required

Order code suffixes		
Material	Suffix surface and material	Example
Steel, zinc plated, Cr(VI)-free	CF	R-320FTFRCF
Stainless steel	SS	R-320FTFRSS

Retaining ring hose couplings

SAE 3000/ISO 6162-1 or ISO 6162-2

X5 and K5 Flange - Straight

Full flange system for ISO 6162-1 or ISO 6162-2

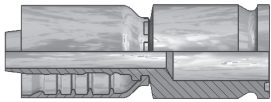

1X577-...



KX5V6-...

X7 and K7 Flange - 45° Elbow

Full flange system for ISO 6162-1 or ISO 6162-2

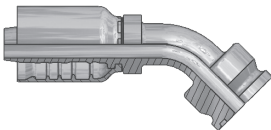

1X777-...



KX7V6-...

X9 and K9 Flange - 90° Elbow

Full flange system for ISO 6162-1 or ISO 6162-2

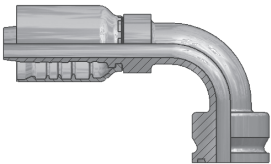

1X977-...

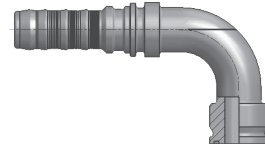

KX9V6-...

Details about hose fittings and the associated hose types can be found in the catalog of PHDE CAT/4400/UK.

WA – Weld adapter connection

SAE 3000/ISO 6162-1

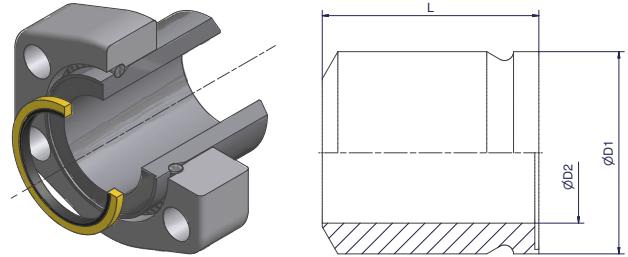

Size Inch	Tube	Complete Part Order code	Retaining Ring	Bonded Seal	Flange Order code	Weld Adapter Body Order code	D1	D2	L	Weight (Steel) kg/1 kit
1/2	12X1.5	R-308WA-12X1.5S	R08X	BS08SNX	R-308-CFX	WA08-12X1.5SX	26	9	40	0.29
1/2	16X2.0	R-308WA-16X2.0S	R08X	BS08SNX	R-308-CFX	WA08-16X2.0SX	26	12	40	0.30
1/2	18X2.0	R-308WA-18X2.0S	R08X	BS08SNX	R-308-CFX	WA08-18X2.0SX	26	14	40	0.30
1/2	20X2.5	R-308WA-20X2.5S	R08X	BS08SNX	R-308-CFX	WA08-20X2.5SX	26	15	40	0.30
1/2	21.3X2.1	R-308WA-21.3X2.1S	R08X	BS08SNX	R-308-CFX	WA08-21.3X2.1SX	26	17	40	0.30
1/2	21.3X2.8	R-308WA-21.3X2.8S	R08X	BS08SNX	R-308-CFX	WA08-21.3X2.8SX	26	16	40	0.30
1/2	21.3X3.7	R-308WA-21.3X3.7S	R08X	BS08SNX	R-308-CFX	WA08-21.3X3.7SX	26	14	45	0.31
1/2	21.3X4.8	R-308WA-21.3X4.8S	R08X	BS08SNX	R-308-CFX	WA08-21.3X4.8SX	26	12	45	0.32
1/2	21.3X7.5	R-308WA-21.3X7.5S	R08X	BS08SNX	R-308-CFX	WA08-21.3X7.5SX	26	6	45	0.32
1/2	25X2.5	R-308WA-25X2.5S	R08X	BS08SNX	R-308-CFX	WA08-25X2.5SX	26	14	40	0.29
1/2	26X6.0	R-308WA-26X6.0S	R08X	BS08SNX	R-308-CFX	WA08-26X6.0SX	26	14	40	0.31
3/4	20X2.5	R-312WA-20X2.5S	R12X	BS12SNX	R-312-CFX	WA12-20X2.5SX	36	15	45	0.41
3/4	25X3.0	R-312WA-25X3.0S	R12X	BS12SNX	R-312-CFX	WA12-25X3.0SX	36	19	45	0.41
3/4	26.7X2.1	R-312WA-26.7X2.1S	R12X	BS12SNX	R-312-CFX	WA12-26.7X2.1SX	36	20	45	0.40
3/4	26.7X2.8	R-312WA-26.7X2.8S	R12X	BS12SNX	R-312-CFX	WA12-26.7X2.8SX	36	20	45	0.41
3/4	26.7X3.9	R-312WA-26.7X3.9S	R12X	BS12SNX	R-312-CFX	WA12-26.7X3.9SX	36	19	45	0.41
3/4	26.7X5.6	R-312WA-26.7X5.6S	R12X	BS12SNX	R-312-CFX	WA12-26.7X5.6SX	36	16	50	0.44
3/4	26.7X7.8	R-312WA-26.7X7.8S	R12X	BS12SNX	R-312-CFX	WA12-26.7X7.8SX	36	11	50	0.45
3/4	30X3.0	R-312WA-30X3.0S	R12X	BS12SNX	R-312-CFX	WA12-30X3.0SX	36	20	50	0.41
3/4	30X4.0	R-312WA-30X4.0S	R12X	BS12SNX	R-312-CFX	WA12-30X4.0SX	36	20	50	0.42
3/4	30X6.0	R-312WA-30X6.0S	R12X	BS12SNX	R-312-CFX	WA12-30X6.0SX	36	18	50	0.44
3/4	30X8.0	R-312WA-30X8.0S	R12X	BS12SNX	R-312-CFX	WA12-30X8.0SX	36	14	50	0.46
1	25X3.0	R-316WA-25X3.0S	R16X	BS16SNX	R-316-CFX	WA16-25X3.0SX	39	19	60	0.61
1	30X4.0	R-316WA-30X4.0S	R16X	BS16SNX	R-316-CFX	WA16-30X4.0SX	39	20	60	0.60
1	33.4X2.8	R-316WA-33.4X2.8S	R16X	BS16SNX	R-316-CFX	WA16-33.4X2.8SX	39	24	60	0.56
1	33.4X3.4	R-316WA-33.4X3.4S	R16X	BS16SNX	R-316-CFX	WA16-33.4X3.4SX	39	24	60	0.57
1	33.4X4.6	R-316WA-33.4X4.6S	R16X	BS16SNX	R-316-CFX	WA16-33.4X4.6SX	39	24	60	0.59
1	33.4X6.5	R-316WA-33.4X6.5S	R16X	BS16SNX	R-316-CFX	WA16-33.4X6.5SX	39	20	60	0.65
1	33.4X9.1	R-316WA-33.4X9.1S	R16X	BS16SNX	R-316-CFX	WA16-33.4X9.1SX	39	15	60	0.64
1	38X4.0	R-316WA-38X4.0S	R16X	BS16SNX	R-316-CFX	WA16-38X4.0SX	39	24	55	0.54
1	38X5.0	R-316WA-38X5.0S	R16X	BS16SNX	R-316-CFX	WA16-38X5.0SX	39	24	55	0.56
1	38X7.0	R-316WA-38X7.0S	R16X	BS16SNX	R-316-CFX	WA16-38X7.0SX	39	24	60	0.62
1	39X7.5	R-316WA-39X7.5S	R16X	BS16SNX	R-316-CFX	WA16-39X7.5SX	39	24	50	0.57
1 1/4	30X4.0	R-320WA-30X4.0S	R20X	BS20SNX	R-320-CFX	WA20-30X4.0SX	46	22	70	1.04
1 1/4	38X4.0	R-320WA-38X4.0S	R20X	BS20SNX	R-320-CFX	WA20-38X4.0SX	46	30	65	0.89
1 1/4	38X5.0	R-320WA-38X5.0S	R20X	BS20SNX	R-320-CFX	WA20-38X5.0SX	46	28	65	0.94
1 1/4	42X3.0	R-320WA-42X3.0S	R20X	BS20SNX	R-320-CFX	WA20-42X3.0SX	46	30	65	0.84
1 1/4	42X4.0	R-320WA-42X4.0S	R20X	BS20SNX	R-320-CFX	WA20-42X4.0SX	46	30	65	0.87
1 1/4	42X6.0	R-320WA-42X6.0S	R20X	BS20SNX	R-320-CFX	WA20-42X6.0SX	46	30	65	0.93
1 1/4	42.2X2.7	R-320WA-42.2X2.7S	R20X	BS20SNX	R-320-CFX	WA20-42.2X2.7SX	46	30	65	0.83
1 1/4	42.2X3.6	R-320WA-42.2X3.6S	R20X	BS20SNX	R-320-CFX	WA20-42.2X3.6SX	46	30	65	0.86
1 1/4	42.2X4.9	R-320WA-42.2X4.9S	R20X	BS20SNX	R-320-CFX	WA20-42.2X4.9SX	46	30	65	0.90
1 1/4	42.2X6.4	R-320WA-42.2X6.4S	R20X	BS20SNX	R-320-CFX	WA20-42.2X6.4SX	46	29	65	0.94
1 1/4	42.2X9.7	R-320WA-42.2X9.7S	R20X	BS20SNX	R-320-CFX	WA20-42.2X9.7SX	46	23	65	1.06
1 1/4	46X7.0	R-320WA-46X7.0S	R20X	BS20SNX	R-320-CFX	WA20-46X7.0SX	46	30	65	0.95
1 1/4	46X8.0	R-320WA-46X8.0S	R20X	BS20SNX	R-320-CFX	WA20-46X8.0SX	46	30	55	0.88
1 1/2	38X5.0	R-324WA-38X5.0S	R24X	BS24SNX	R-324-CFX	WA24-38X5.0SX	56	28	75	1.45
1 1/2	48.3X2.8	R-324WA-48.3X2.8S	R24X	BS24SNX	R-324-CFX	WA24-48.3X2.8SX	56	39	70	1.11
1 1/2	48.3X3.7	R-324WA-48.3X3.7S	R24X	BS24SNX	R-324-CFX	WA24-48.3X3.7SX	56	39	70	1.15
1 1/2	48.3X5.1	R-324WA-48.3X5.1S	R24X	BS24SNX	R-324-CFX	WA24-48.3X5.1SX	56	38	70	1.21

see next page

WA – Weld adapter connection continued

SAE 3000/ISO 6162-1

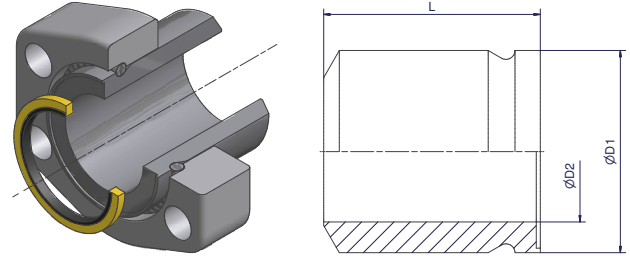

Size Inch	Tube	Complete Part Order code	Retaining Ring	Bonded Seal	Flange Order code	Weld Adapter Body Order code	D1	D2	L	Weight (Steel) kg/1 kit
1 1/2	48.3X7.1	R-324WA-48.3X7.1S	R24X	BS24SNX	R-324-CFX	WA24-48.3X7.1SX	56	34	70	1.33
1 1/2	48.3X10.2	R-324WA-48.3X10.2S	R24X	BS24SNX	R-324-CFX	WA24-48.3X10.2SX	56	28	70	1.29
1 1/2	50X3.0	R-324WA-50X3.0S	R24X	BS24SNX	R-324-CFX	WA24-50X3.0SX	56	39	70	1.10
1 1/2	50X5.0	R-324WA-50X5.0S	R24X	BS24SNX	R-324-CFX	WA24-50X5.0SX	56	40	70	1.17
1 1/2	50X6.0	R-324WA-50X6.0S	R24X	BS24SNX	R-324-CFX	WA24-50X6.0SX	56	38	70	1.23
1 1/2	50X9.0	R-324WA-50X9.0S	R24X	BS24SNX	R-324-CFX	WA24-50X9.0SX	56	32	70	1.39
1 1/2	56X8.5	R-324WA-56X8.5S	R24X	BS24SNX	R-324-CFX	WA24-56X8.5SX	56	39	60	1.15
2	48.3X5.6	R-332WA-48.3X5.6S	R32X	BS32SNX	R-332-CFX	WA32-48.3X5.6SX	66	37	90	2.30
2	50X9.0	R-332WA-50X9.0S	R32X	BS32SNX	R-332-CFX	WA32-50X9.0SX	66	32	90	2.51
2	60X3.0	R-332WA-60X3.0S	R32X	BS32SNX	R-332-CFX	WA32-60X3.0SX	66	49	90	1.79
2	60X5.0	R-332WA-60X5.0S	R32X	BS32SNX	R-332-CFX	WA32-60X5.0SX	66	50	90	1.89
2	60X6.0	R-332WA-60X6.0S	R32X	BS32SNX	R-332-CFX	WA32-60X6.0SX	66	48	90	2.00
2	60X8.0	R-332WA-60X8.0S	R32X	BS32SNX	R-332-CFX	WA32-60X8.0SX	66	44	90	2.18
2	60X10.0	R-332WA-60X10.0S	R32X	BS32SNX	R-332-CFX	WA32-60X10.0SX	66	40	90	2.36
2	60.3X2.8	R-332WA-60.3X2.8S	R32X	BS32SNX	R-332-CFX	WA32-60.3X2.8SX	66	49	90	1.77
2	60.3X3.9	R-332WA-60.3X3.9S	R32X	BS32SNX	R-332-CFX	WA32-60.3X3.9SX	66	49	90	1.85
2	60.3X5.5	R-332WA-60.3X5.5S	R32X	BS32SNX	R-332-CFX	WA32-60.3X5.5SX	66	49	90	1.94
2	60.3X8.7	R-332WA-60.3X8.7S	R32X	BS32SNX	R-332-CFX	WA32-60.3X8.7SX	66	43	90	2.24
2	60.3X11.1	R-332WA-60.3X11.1S	R32X	BS32SNX	R-332-CFX	WA32-60.3X11.1SX	66	38	90	2.44
2	66X8.5	R-332WA-66X8.5S	R32X	BS32SNX	R-332-CFX	WA32-66X8.5SX	66	49	75	1.85
2 1/2	65X8.5	R-340WA-65X8.5S	R40X	BS40SNX	R-340-CFX	WA40-65X8.5SX	80	49	105	3.80
2 1/2	73X7.0	R-340WA-73X7.0S	R40X	BS40SNX	R-340-CFX	WA40-73X7.0SX	80	59	105	3.29
2 1/2	75X3.0	R-340WA-75X3.0S	R40X	BS40SNX	R-340-CFX	WA40-75X3.0SX	80	60	105	2.90
2 1/2	75X5.0	R-340WA-75X5.0S	R40X	BS40SNX	R-340-CFX	WA40-75X5.0SX	80	60	105	3.07
2 1/2	76.1X6.3	R-340WA-76.1X6.3S	R40X	BS40SNX	R-340-CFX	WA40-76.1X6.3SX	80	60	105	3.15
2 1/2	76.1X12.5	R-340WA-76.1X12.5S	R40X	BS40SNX	R-340-CFX	WA40-76.1X12.5SX	80	51	105	3.87
2 1/2	80X10.0	R-340WA-80X10.0S	R40X	BS40SNX	R-340-CFX	WA40-80X10.0SX	80	60	90	3.10
3	76.1X12.5	R-348WA-76.1X12.5S	R48X	BS48SNX	R-348-CFX	WA48-76.1X12.5SX	97	51	120	5.68
3	80X10.0	R-348WA-80X10.0S	R48X	BS48SNX	R-348-CFX	WA48-80X10.0SX	97	60	120	5.57
3	88.9X3.1	R-348WA-88.9X3.1S	R48X	BS48SNX	R-348-CFX	WA48-88.9X3.1SX	97	73	120	4.68
3	88.9X5.5	R-348WA-88.9X5.5S	R48X	BS48SNX	R-348-CFX	WA48-88.9X5.5SX	97	73	120	4.97
3	88.9X7.7	R-348WA-88.9X7.7S	R48X	BS48SNX	R-348-CFX	WA48-88.9X7.7SX	97	74	120	5.17
3	88.9X8.8	R-348WA-88.9X8.8S	R48X	BS48SNX	R-348-CFX	WA48-88.9X8.8SX	97	71	120	5.40
3	88.9X11.1	R-348WA-88.9X11.1S	R48X	BS48SNX	R-348-CFX	WA48-88.9X11.1SX	97	67	120	5.84
3	88.9X12.5	R-348WA-88.9X12.5S	R48X	BS48SNX	R-348-CFX	WA48-88.9X12.5SX	97	64	120	6.10
3	88.9X15.2	R-348WA-88.9X15.2S	R48X	BS48SNX	R-348-CFX	WA48-88.9X15.2SX	97	59	120	6.50
3	90X3.5	R-348WA-90X3.5S	R48X	BS48SNX	R-348-CFX	WA48-90X3.5SX	97	73	120	4.69
3	90X5.0	R-348WA-90X5.0S	R48X	BS48SNX	R-348-CFX	WA48-90X5.0SX	97	80	120	5.00
3	90X9.0	R-348WA-90X9.0S	R48X	BS48SNX	R-348-CFX	WA48-90X9.0SX	97	72	120	5.35
3	97X12.0	R-348WA-97X12.0S	R48X	BS48SNX	R-348-CFX	WA48-97X12.0SX	97	73	110	5.15

Other sizes on request.

Please change suffixes according to material/surface required

Order code suffixes		
Material	Suffix surface and material	Example
Steel	S	R-320WA-42X3.0S
Stainless steel	SS	R-320WA-42X3.SS



BF – Bulkhead flange

SAE 3000/ISO 6162-1

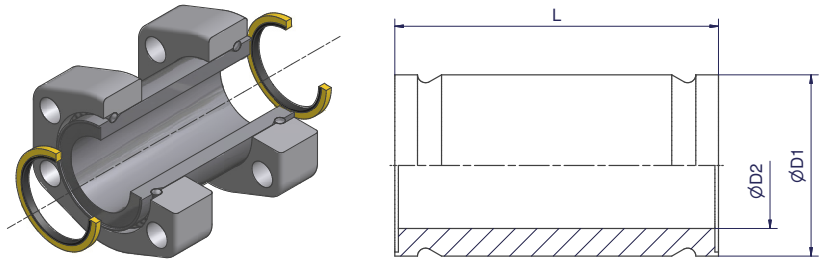

Size Inch	Complete Part Order code	Bulkhead Body Order code	D1	D2	L	Weight body (Steel) kg/1 piece
1/2	R-308BFS	BF08SX	26	14	170	0.49
3/4	R-312BFS	BF12SX	36	20	170	0.92
1	R-316BFS	BF16SX	39	24	170	0.96
1 1/4	R-320BFS	BF20SX	46	30	180	1.30
1 1/2	R-324BFS	BF24SX	56	39	180	1.75
2	R-332BFS	BF32SX	66	49	210	2.45
2 1/2	R-340BFS	BF40SX	80	60	220	3.70
3	R-348BFS	BF48SX	97	73	240	7.85

Please change suffixes according to material/surface required

Order code suffixes		
Material	Suffix surface and material	Example
Steel	S	R-320BFS
Stainless steel	SS	R-320BFSS

RF – Reducer flange

SAE 3000/ISO 6162-1

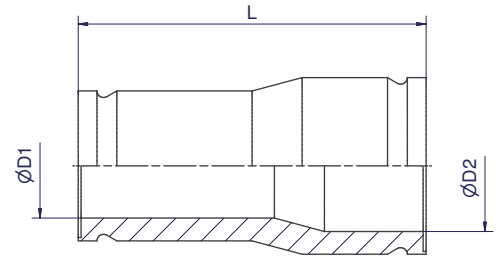
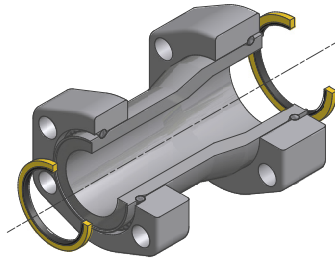

Size Inch	Complete Part Order code	Reducer Body Order code	D1	D2	L	Weight body (Steel) kg/1 piece
3/4 - 1/2	R-312-308RFCF	RF12-08CFX	14	20	65	0.3
1 - 1/2	R-316-308RFCF	RF16-08CFX	14	24	100	0.4
1 - 3/4	R-316-312RFCF	RF16-12CFX	20	24	100	0.6
1 1/4 - 1	R-320-316RFCF	RF20-16CFX	24	30	110	0.7
1 1/2 - 1	R-324-316RFCF	RF24-16CFX	24	39	115	0.9
1 1/2 - 1 1/4	R-324-320RFCF	RF24-20CFX	30	39	130	1.1
2 - 1 1/4	R-332-320RFCF	RF32-20CFX	30	49	130	1.3
2 - 1 1/2	R-332-324RFCF	RF32-24CFX	39	49	130	1.4
2 1/2 - 1 1/2	R-340-324RFCF	RF40-24CFX	39	60	150	2.1
2 1/2 - 2	R-340-332RFCF	RF40-32CFX	49	60	150	2.2
3 - 2	R-348-332RFCF	RF48-32CFX	49	73	180	3.4
3 - 2 1/2	R-348-340RFCF	RF48-40CFX	60	73	180	3.7

Other sizes on request.

Please change suffixes according to material/surface required

Order code suffixes		
Material	Suffix surface and material	Example
Steel, zinc plated, Cr(VI)-free	CF	R-320-316RFCF
Stainless steel	SS	R-320-316RFSS



FB90 – 90° Flange bend

SAE 3000/ISO 6162-1

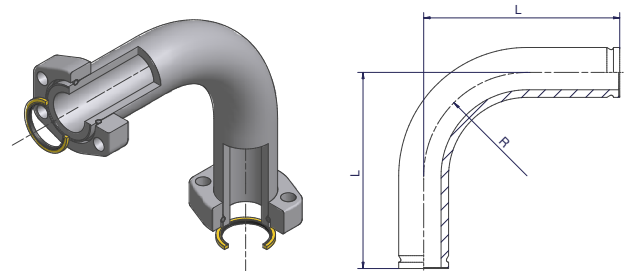

Size Inch	Tube	Complete Part Order code	90° Flange Bend Order code	L	R	Weight body (Steel) kg/1 piece
1 1/4	46X8.0	R-320FB90S	FB90-20SX*	180	96	2.35
1 1/2	56X8.5	R-324FB90CF	FB90-24CFX	220	116	3.84
2	66X8.5	R-332FB90CF	FB90-32CFX	275	165	5.72
2 1/2	80X10.0	R-340FB90S*	FB90-40SX*	370	200	11.20
3	97X12.0	R-348FB90S*	FB90-48SX*	450	243	19.90

Other sizes on request.
*only available as steel version

Please change suffixes according to material/surface required

Order code suffixes			
Tube material	Suffix surface and material	Example	Comments
Steel, zinc plated, Cr(VI)-free	CFX	R-324FB90CF	
Steel, black phosphated	SX	R-320FB90S	
Stainless steel	SS	R-320FB90SS	on request

FB45 – 45° Flange bend

SAE 3000/ISO 6162-1

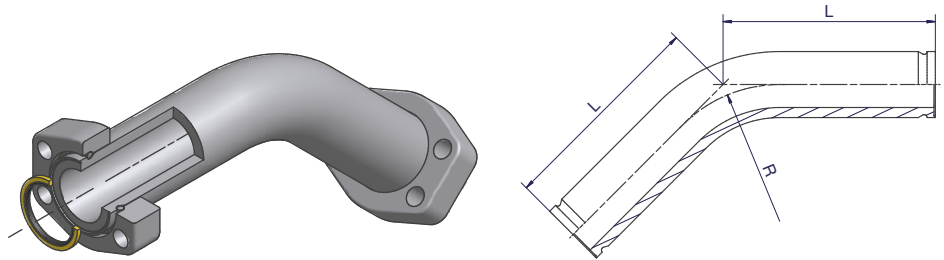

Size Inch	Tube	Complete Part Order code	45° Flange Bend Order code	L	R	Weight body (Steel) kg/1 piece
1 1/4	46X8.0	R-320FB45S	FB45-20SX	150	96	2.18
1 1/2	56X8.5	R-324FB45CF	FB45-24CFX	180	116	3.49
2	66X8.5	R-332FB45CF	FB45-32CFX	220	165	5.16
2 1/2	80X10.0	R-340FB45S*	FB45-40SX*	240	200	8.07
3	97X12.0	R-348FB45S*	FB45-48SX*	260	243	12.70

Other sizes on request.
*only available as steel version

Please change suffixes according to material/surface required

Order code suffixes			
Tube material	Suffix surface and material	Example	Comments
Steel, zinc plated, Cr(VI)-free	CFX	R-324FB45CF	
Steel, black phosphated	SX	R-320FB45S	
Stainless steel	SS	R-320FB45SS	on request



FB90 – 90° Flange bend

SAE 3000/ISO 6162-1

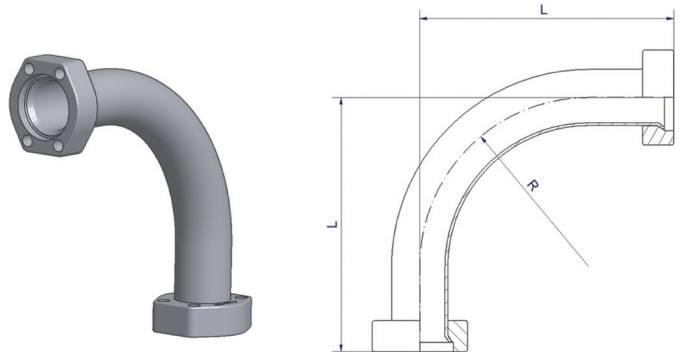

Size Inch	Tube	Complete Part Order code	L	R
1 1/2	50X5.0	F37-324FB90	220	150.0
2	60X5.0	F37-332FB90	275	180.0
2 1/2	75X5.0	F37-340FB90	370	187.5
3	90X3.5	F37-348FB90*	450	225.0
3	90x5.0	F37-348905FB90*	450	225.0

Other sizes on request.
 *only available as Steel version, example: F37-348FB90S

Please change suffixes according to material/surface required

Order code suffixes		
Material	Suffix surface and material	Example
Steel, zinc plated, Cr(VI)-free	CF	F37-324FB90CF
Steel	S	F37-348FB90S
Stainless steel	SS	F37-324FB90SS

FB45 – 45° Flange bend

SAE 3000/ISO 6162-1

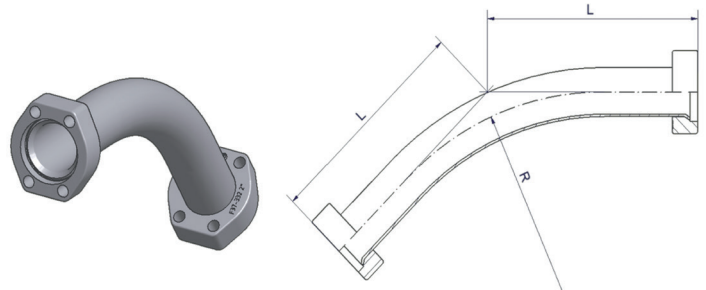

Size Inch	Tube	Complete Part Order code	L	R
1 1/2	50X5.0	F37-324FB45	220	150.0
2	60X5.0	F37-332FB45	275	180.0
2 1/2	75X5.0	F37-340FB45	370	187.5
3	90X5.0	F37-348905FB45*	370	187.5

Other sizes on request.

*only available as Steel Version, example: F37-348905FB45S

Please change suffixes according to material/surface required

Order code suffixes		
Material	Suffix surface and material	Example
Steel, zinc plated, Cr(VI)-free	CF	F37-324FB45CF
Steel	S	F37-348905FB45S
Stainless steel	SS	F37-324FB45SS



LF – Elbow flange

SAE 3000/ISO 6162-1

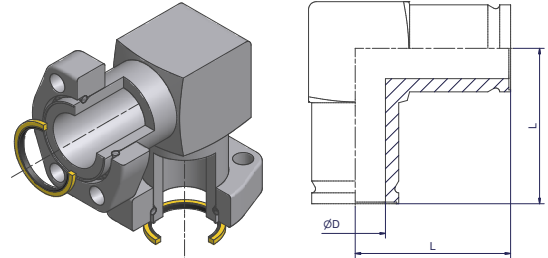

Size Inch	Complete Part Order code	Elbow Flange body Order code	D	L	Weight body (Steel) kg/1 piece
1/2	R-308LFCF	LF08CFX	14	70	0.50
3/4	R-312LFCF	LF12CFX	20	80	1.07
1	R-316LFCF	LF16CFX	24	85	1.32
1 1/4	R-320LFCF	LF20CFX	30	90	1.72
1 1/2	R-324LFCF	LF24CFX	39	100	2.60
2	R-332LFCF	LF32CFX	49	110	4.00
2 1/2	R-340LFCF	LF40CFX	60	130	6.40
3	R-348LFCF	LF48CFX	73	160	10.80

Other sizes on request.

Please change suffixes according to material/surface required

Order code suffixes		
Material	Suffix surface and material	Example
Steel, zinc plated, Cr(VI)-free	CF	R-320LFCF
Stainless steel	SS	R-320LFSS

TF – TEE flange

SAE 3000/ISO 6162-1

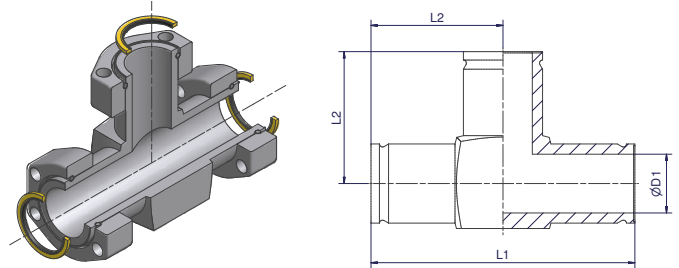

Size Inch	Complete Part Order code	Tee Flange body Order code	D1	L1	L2	Weight body (Steel) kg/1 piece
1/2	R-308TFCF	TF08CFX	14	120	60	0.75
3/4	R-312TFCF	TF12CFX	20	130	65	1.60
1	R-316TFCF	TF16CFX	24	140	70	2.00
1 1/4	R-320TFCF	TF20CFX	30	180	90	2.03
1 1/2	R-324TFCF	TF24CFX	39	200	100	3.13
2	R-332TFCF	TF32CFX	49	220	110	4.53
2 1/2	R-340TFCF	TF40CFX	60	260	130	7.05
3	R-348TFCF	TF48CFX	73	320	160	12.81

Other sizes on request.

Please change suffixes according to material/surface required

Order code suffixes		
Material	Suffix surface and material	Example
Steel, zinc plated, Cr(VI)-free	CF	R-320TFCF
Stainless steel	SS	R-320TFSS



LB – Flange L-block

SAE 3000/ISO 6162-1

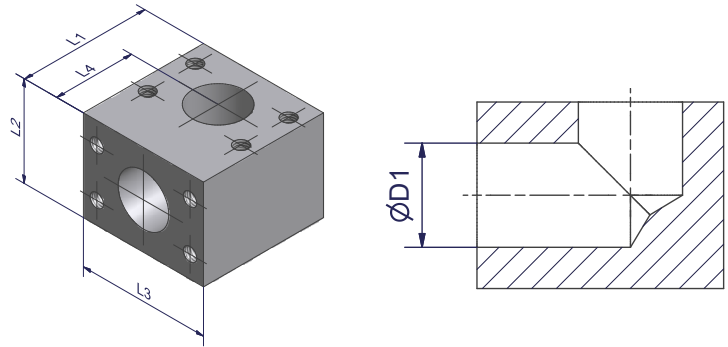

Size Inch	Order code	D1	L1	L2	L3	L4	Weight (Steel) kg/1 piece
1	LB316CFX	25	70	48	70	46	1.5
1 1/4	LB320CFX	30	80	58	80	51	2.4
1 1/2	LB324CFX	38	90	68	90	56	3.4
2	LB332CFX	48	96	78	100	57	4.4
2 1/2	LB340CFX	60	110	88	110	65	6.0
3	LB348CFX	73	135	110	135	80	11.3

Other sizes and custom versions on request.

Please change suffixes according to material/surface required

Order code suffixes		
Material	Suffix surface and material	Example
Steel, zinc plated, Cr(VI)-free	CF	LB320CFX
Stainless steel	SS	LB320SSX

LBR – Flange L-block reducer

SAE 3000/ISO 6162-1

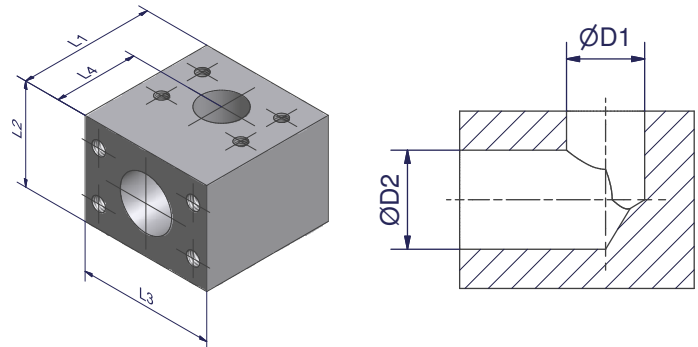

Size Inch	Order code	D1	D2	L1	L2	L3	L4	Weight (Steel) kg/1 piece
1 1/4 - 1	LBR320-316CFX	25	30	80	58	80	51	2.4
1 1/2 - 1	LBR324-316CFX	25	38	90	68	90	56	3.6
1 1/2 - 1 1/4	LBR324-320CFX	30	38	90	68	90	56	3.6
2 - 1	LBR332-316CFX	25	48	96	78	100	57	4.7
2 - 1 1/4	LBR332-320CFX	30	48	96	78	100	57	4.7
2 - 1 1/2	LBR332-324CFX	38	48	96	78	100	57	4.6
2 1/2 - 1 1/2	LBR340-324CFX	38	60	110	88	110	65	6.4
2 1/2 - 2	LBR340-332CFX	48	60	110	88	110	65	6.2
3 - 2	LBR348-332CFX	48	73	135	110	135	80	12.2
3 - 2 1/2	LBR348-340CFX	60	73	135	110	135	80	11.8

Other sizes and custom versions on request.

Please change suffixes according to material/surface required

Order code suffixes		
Material	Suffix surface and material	Example
Steel, zinc plated, Cr(VI)-free	CF	LBR320-316CFX
Stainless steel	SS	LBR320-316SSX



TB – Flange T-block

SAE 3000/ISO 6162-1

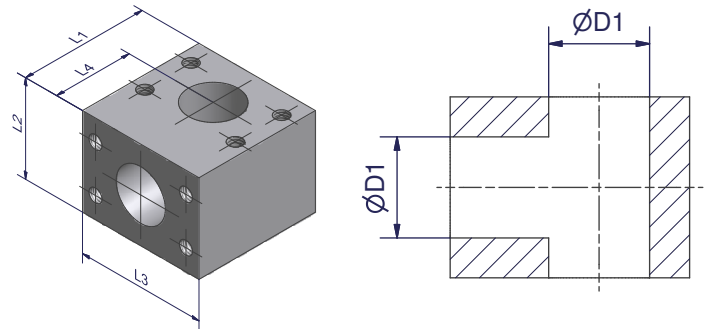

Size Inch	Order code	D1	L1	L2	L3	L4	Weight (Steel) kg/1 piece
1/2	TB308CFX	13	60	50	60	37	1.2
3/4	TB312CFX	19	68	55	66	44	1.6
1	TB316CFX	25	70	55	70	46	1.6
1 1/4	TB320CFX	30	80	58	80	51	2.2
1 1/2	TB324CFX	38	90	68	90	56	3.1
2	TB332CFX	48	96	78	100	57	3.9
2 1/2	TB340CFX	60	110	88	110	65	5.3
3	TB348CFX	73	135	110	135	80	10.0

Other sizes and custom versions on request.

Please change suffixes according to material/surface required

Order code suffixes		
Material	Suffix surface and material	Example
Steel, zinc plated, Cr(VI)-free	CF	TB320CFX
Stainless steel	SS	TB320SSX

TBR – Flange T-block reducer

SAE 3000/ISO 6162-1

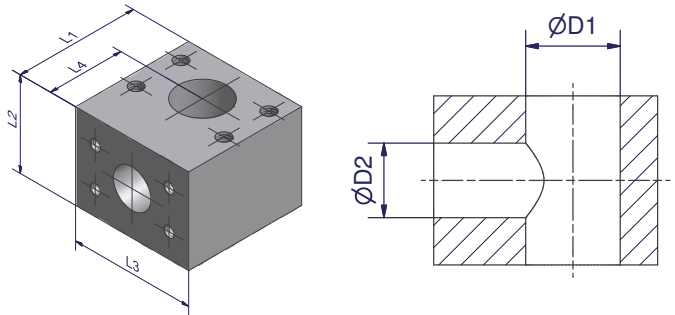

Size Inch	Order code	D1	D2	L1	L2	L3	L4	Weight (Steel) kg/1 piece
1 1/4 - 3/4 - 1 1/4	TBR320-312-320CFX	30	19	80	55	80	51	2.2
1 1/4 - 1 - 1 1/4	TBR320-316-320CFX	30	25	80	58	80	51	2.3
1 1/2 - 1 1/4 - 1 1/2	TBR324-320-324CFX	38	30	90	68	90	56	3.3
1 1/2 - 1 - 1 1/2	TBR324-316-324CFX	38	25	90	68	90	56	3.4
2 - 1 1/2 - 2	TBR332-324-332CFX	48	38	96	78	100	57	4.2
2 - 1 1/4 - 2	TBR332-320-332CFX	48	30	96	78	100	57	4.3
2 1/2 - 2 - 2 1/2	TBR340-332-340CFX	60	48	110	88	110	65	5.6
2 1/2 - 1 1/2 - 2 1/2	TBR340-324-340CFX	60	38	110	88	110	65	5.9
3 - 2 1/2 - 3	TBR348-340-348CFX	73	60	135	110	135	80	10.6
3 - 2 - 3	TBR348-332-348CFX	73	48	135	110	135	80	11.0

Other sizes and custom versions on request.

Please change suffixes according to material/surface required

Order code suffixes		
Material	Suffix surface and material	Example
Steel, zinc plated, Cr(VI)-free	CF	TBR320-316-320CFX
Stainless steel	SS	TBR320-316-320SSX



BFV – Blind flange

SAE 3000/ISO 6162-1

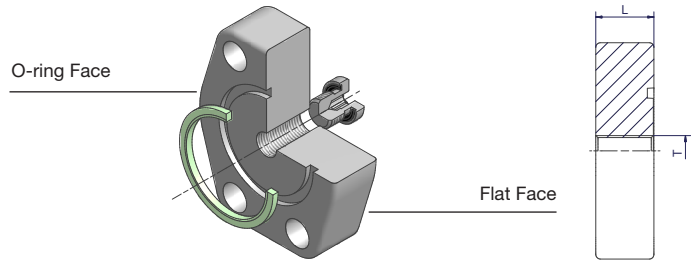

Size Inch	Flange incl. VSTI-ED and F37 Seal Order code	L	T	Weight body (Steel) kg/1 piece
1/2	F37-308BFVCF	19	G 1/4	0.24
3/4	F37-312BFVCF	20	G 1/4	0.37
1	F37-316BFVCF	24	G 1/4	0.60
1 1/4	F37-320BFVCF	22	G 1/4	0.70
1 1/2	F37-324BFVCF	25	G 1/4	1.10
2	F37-332BFVCF	33	G 1/4	2.00
2 1/2	F37-340BFVCF	44	G 1/4	3.45
3	F37-348BFVCF	50	G 1/4	5.45

Please change suffixes according to material/surface required

Order code suffixes		
Material	Suffix surface and material	Example
Steel, zinc plated, Cr(VI)-free	CF	F37-320BFVCF
Stainless steel	SS	F37-320BFVSS

BS – Bonded seal

SAE 3000/ISO 6162-1

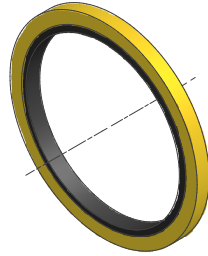

Size Inch	Steel	Stainless Steel
1/2	BS08SNX	BS08SSNX
3/4	BS12SNX	BS12SSNX
1	BS16SNX	BS16SSNX
1 1/4	BS20SNX	BS20SSNX
1 1/2	BS24SNX	BS24SSNX
2	BS32SNX	BS32SSNX
2 1/2	BS40SNX	BS40SSNX
3	BS48SNX	BS48SSNX

Sealing: NBR
Other sealing materials like FKM on request.

F37S/F37RS – F37 seal

SAE 3000/ISO 6162-1

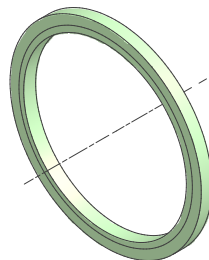

Size Inch	F37 Seal (F37 seal for flaring system)	F37 RS (F37 seal for retaining ring system)
1/2	F37S08X	-
3/4	F37S12X	-
1	F37S16X	-
1 1/4	F37S20X	F37RS20X
1 1/2	F37S24X	F37RS24X
2	F37S32X	F37RS32X
2 1/2	F37S40X	F37RS40X
3	F37S48X	F37RS48X

Sealing: Polyurethane
Material properties and applications see page 22.
Other sizes on request.



AO – Adapter bonded seal to F37 seal/O-Ring

SAE 3000/ISO 6162-1

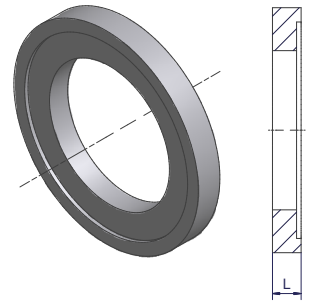

Size Inch	Adapter Order code	L	Weight (Steel) kg/1 piece
1/2	AO08CFX	5	0.01
3/4	AO12CFX	5	0.02
1	AO16CFX	7	0.06
1 1/4	AO20CFX	7	0.06
1 1/2	AO24CFX	7	0.08
2	AO32CFX	7	0.10
2 1/2	AO40CFX	7	0.14
3	AO48CFX	7	0.20

Please change suffixes according to material/surface required

Order code suffixes		
Material	Suffix surface and material	Example
Steel, zinc plated, Cr(VI)-free	CF	AO32CFX
Stainless steel	SS	AO32SSX

TBT – TEE between bonded seal

SAE 3000/ISO 6162-1

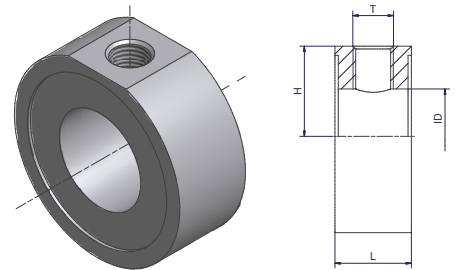

Size Inch	Order code*	L	H	T	ID	Weight body (Steel) kg/1 piece
1	TBT16-1/4CFX	25	20.5	G 1/4 A	25	0.21
1 1/4	TBT20-1/4CFX	25	24.5	G 1/4 A	27	0.30
1 1/4	TBT20-1/2CFX	40	22.5	G 1/2 A	24	0.49
1 1/2	TBT24-1/4CFX	25	29.5	G 1/4 A	31	0.42
1 1/2	TBT24-1/2CFX	40	28.0	G 1/2 A	30	0.68
2	TBT32-1/4CFX	25	35.0	G 1/4 A	41	0.51
2	TBT32-1/2CFX	40	34.0	G 1/2 A	38	0.87
2 1/2	TBT40-1/4CFX	30	41.5	G 1/4 A	60	0.63
3	TBT48-1/4CFX	30	50.0	G 1/4 A	72	0.90

*For testpoints and diagnostic test equipment see catalogue 4100, Industrial Tube Fittings Europe.
For assembling add L to the corresponding bolt length.

Alternative versions on request.

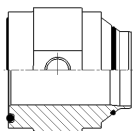

TFVB

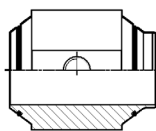

TTb

Please change suffixes according to material/surface required

Order code suffixes		
Material	Suffix surface and material	Example
Steel, zinc plated, Cr(VI)-free	CF	TBT24-1/4CFX
Stainless steel	SS	TBT24-1/4SSX



AP – SAE flange locking plate

SAE 3000/ISO 6162-1

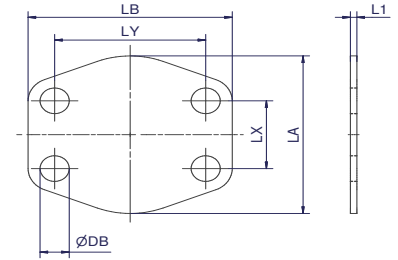

Nom. flange size		Order code	L1	LA	LB	LX	LY	DB	Weight body (Steel) kg/1 piece
SAE (In)	ISO (DN)								
1/2	13	8AP1	3	46	54	17.5	38.1	9.0	0.01
3/4	19	12AP1	3	52	65	22.3	47.6	11.0	0.01
1	25	16AP1	3	59	70	26.2	52.4	11.0	0.01
1 1/4	32	20AP1	3	73	79	30.2	58.7	11.5	0.01
1 1/2	38	24AP1	3	83	94	35.7	69.9	13.5	0.02
2	51	32AP1	3	97	102	42.9	77.8	13.5	0.02
2 1/2	64	40AP1	3	109	114	50.8	88.9	13.5	0.03
3	76	48AP1	4	131	135	61.9	106.4	17.0	0.06

This flange locking plate to be not used under pressure!

Please change suffixes according to material/surface required

Order code suffixes			
Material	Suffix surface and material	Example	Description
Steel, zinc plated, Cr(VI)-free	CF	8AP1CF	only locking plate
Stainless steel	SS	8AP1SS	only locking plate
Steel (zinc plated, Cr(VI)-free), SBR 70 Shore A	CFSBR70	8AP1CFSBR70	locking incl. rubber plate L1 increases due to rubber plate

Bolts and nuts for flange

SAE 3000/ISO 6162-1



F37 Flare Flange

Size Inch	Flange	F37 Seal / Flat Face / Bonded Seal		Nut
		Recommended bolts Tube to Port	Recommended bolts Tube to Tube	
1/2	F37-308-CFX	4x ZYLS8X35	4x ZYLS8X55	4x ISO4032-M8
3/4	F37-312-CFX	4x ZYLS10X40	4x ZYLS10X65	4x ISO4032-M10
1	F37-316-CFX	4x ZYLS10X45	4x ZYLS10X75	4x ISO4032-M10
1 1/4	F37-320-CFX	4x ZYLS10X40	4x ZYLS10X70	4x ISO4032-M10
1 1/2	F37-324-CFX	4x ZYLS12X45	4x ZYLS12X80	4x ISO4032-M12
2	F37-332-CFX	4x ZYLS12X55	4x ZYLS12X100	4x ISO4032-M12
2 1/2	F37-340-CFX	4x ZYLS12X65	4x ZYLS12X120	4x ISO4032-M12
3	F37-348-CFX	4x ZYLS16X80	4x ZYLS16X140	4x ISO4032-M16

Retaining Ring Flange

Size Inch	Flange	F37 Seal / Flat Face / Bonded Seal		Pipe Seal Carrier (PSC)		Nut
		Recommended bolts Tube to Port	Recommended bolts Tube to Tube	Recommended bolts Tube to Port	Recommended bolts Tube to Tube	
1/2	R-308-CFX	4x ZYLS8X35	4x ZYLS8X60	-	-	4x ISO4032-M8
3/4	R-312-CFX	4x ZYLS10X40	4x ZYLS10X65	-	-	4x ISO4032-M10
1	R-316-CFX	4x ZYLS10X40	4x ZYLS10X70	-	-	4x ISO4032-M10
1 1/4	R-320-CFX	4x ZYLS10X40	4x ZYLS10X70	4x ZYLS10X50	4x ZYLS10X80	4x ISO4032-M10
1 1/2	R-324-CFX	4x ZYLS12X50	4x ZYLS12X80	4x ZYLS12X55	4x ZYLS12X90	4x ISO4032-M12
2	R-332-CFX	4x ZYLS12X55	4x ZYLS12X90	4x ZYLS12X65	4x ZYLS12X100	4x ISO4032-M12
2 1/2	R-340-CFX	4x ZYLS12X65	4x ZYLS12X120	4x ZYLS12X80	4x ZYLS12X130	4x ISO4032-M12
3	R-348-CFX	4x ZYLS16X80	4x ZYLS16X130	4x ZYLS16X90	4x ZYLS16X150	4x ISO4032-M16

Bolts and nuts are not included in complete part numbers.

Latest information about nuts and bolts see www.parker.com/hpcc -> Resources -> Installation Guides & Manuals

Please add the suffixes according to the bolt quality

	Steel		Stainless Steel
Grade	8.8 zinc plated (VZX)	10.9 zinc flaked (ZNFLX)	A4-80X
Bolt	ZYLS16X60VZX	ZYLS16X60109ZNFLX	ZYLS16X60A4-80X
Nut	ISO4032-M12-8VZX	ISO4032-M12-10ZNFLX	ISO4032-M12-80X



KH – Ball valve drilled and tapped for SAE 3000 and SAE 6000 Flanges

SAE 3000/ISO 6162-1

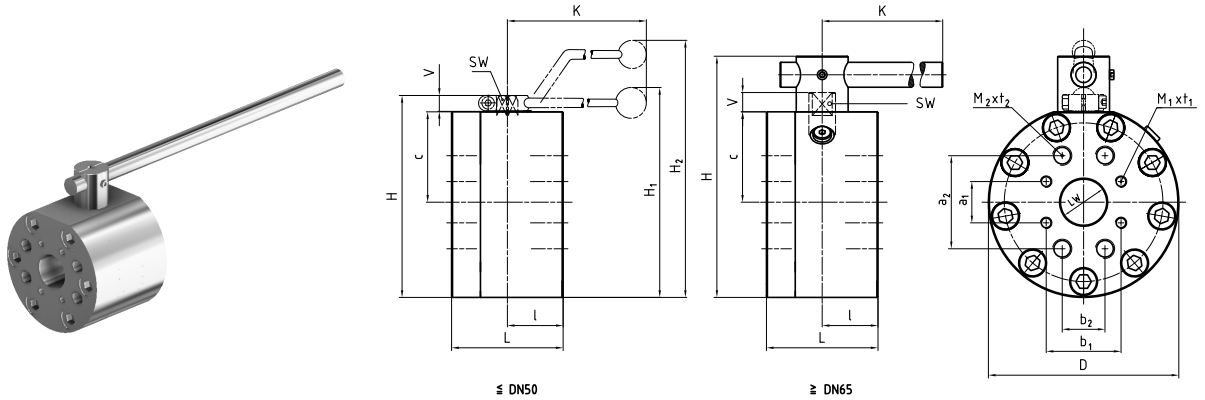

Material Steel

Size Inch	Order Code	DN	LW	L	I	D	H	c	V	K	SW	SAE 3000 boring pattern				SAE 6000 boring pattern				H1	H2	Material Code	Lever	Weight kg	W.P. (bar)
												a1	b1	M1	t1	a2	b2	M2	t2						
1/2	KH08-15CF	15	15	75	35	88	88	31.0	13	170	12	17.5	38.1	M08	18	40.5	18.2	M08	18	-	132	212A	St	2.96	350 / 420
3/4	KH12-20CF	20	20	80	35	98	100	36.5	14	170	14	22.2	47.6	M10	18	50.8	23.8	M10	18	-	150	212A	St	4.20	350 / 420
1	KH16-25CF	25	25	88	38	118	113	39.5	14	170	14	26.2	52.4	M10	20	57.2	27.8	M10	20	-	163	212A	St	6.00	320 / 420
1 1/4	KH20-32CF*	32	32	100	50	145	158	68.0	17	306	17	30.2	58.7	M10	20	66.7	31.8	M12	22	-	232	212A	St	11.70	280 / 420
1 1/4	KH20-32TM1214CF*	32	32	100	50	145	158	68.0	17	306	17	30.2	58.7	M12	20	66.7	31.8	M14	22	-	232	212A	St	11.65	210 / 400
1 1/2	KH24-38CF	40	38	110	55	165	178	78.0	17	306	17	35.7	69.9	M12	20	79.4	36.5	M16	27	-	252	212A	St	17.10	210 / 420
2	KH32-48CF	50	48	116	58	198	210	94.0	17	306	17	42.9	77.8	M12	20	96.8	44.5	M20	28	-	284	212A	St	24.60	210 / 420
2 1/2	KH40-63CF	65	63	170	75	218	275	100.0	20	600	16	88.9	50.8	M12	19	58.7	123.8	M24	41	-	-	282A	St	44.40	175 / 420
3	KH48-76CF	80	76	170	79	258	315	115.0	26	600	19	106.4	61.9	M16	24	71.4	152.4	M30	47	-	-	282A	St	54.90	160 / 420

*Please choose between KH20-32CF and KH20-32TM1214CF according to needed connection threads M1 and M2.
Steel ball valves 1/2" up to 3" with SAE 3000 and SAE 6000 boring pattern.
The bore pattern for 2 1/2" and 3" is turned to 90°.

Please change suffixes according to material/surface required

Order code suffixes		
Material	Suffix surface and material	Example
Steel, zinc plated, Cr(VI)-free	CF	KH20-32CF

	Material 212A	Material 282A
Body	Steel	Steel
Ball	Steel	Steel
Stem	Steel	Stainless Steel
Ball seats	POM	POM
O-Ring	NBR	NBR
Tmin / T max	-10°C / 100°C	-10°C / 100°C

KH – Ball valve drilled and tapped for SAE 3000 Flanges

SAE 3000/ISO 6162-1

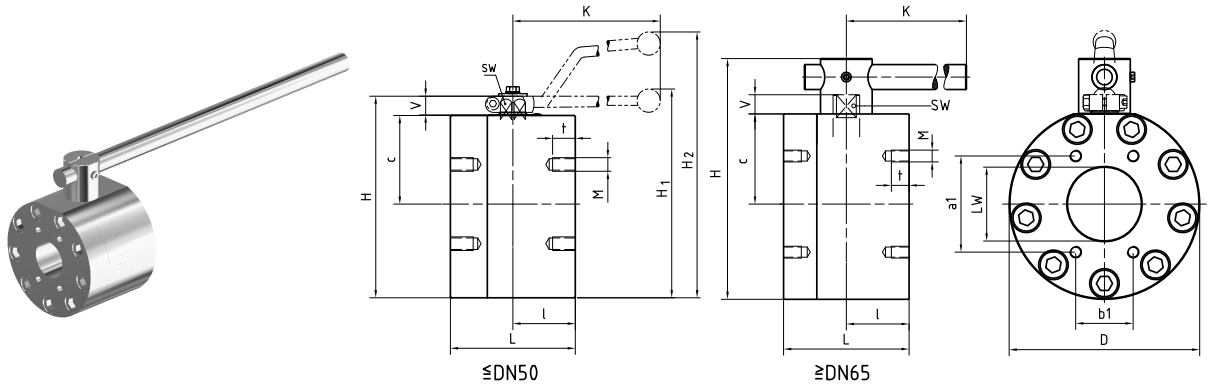

Material Stainless Steel

Size Inch	Order Code	DN	LW	L	I	D	H	c	V	K	SW	a1	b1	M	t	H1	H2	Material Code	Lever	Weight kg	W.P. (bar)
1/2	KH308-15SS	15	15	75	35	78	83	31.0	13	160	12	38.1	17.5	M08	18	-	127	442A	Al	2.96	350
3/4	KH312-20SS	20	20	80	35	98	100	36.5	14	200	14	47.6	22.2	M10	18	103	-	442A	Zn	4.20	350
1	KH316-25SS	25	25	88	38	118	113	39.5	14	200	14	52.4	26.2	M10	20	116	-	442A	Zn	6.00	320
1 1/4	KH320-32SS*	32	32	100	50	145	158	68.0	17	320	17	58.7	30.2	M10	20	167	-	442A	Al	11.70	280
1 1/4	KH320-32TM12SS*	32	32	100	50	145	158	68.0	17	320	17	58.7	30.2	M12	20	167	-	442A	Al	11.65	210
1 1/2	KH324-38SS	40	38	110	55	165	178	78.0	17	320	17	69.9	35.7	M12	20	187	-	442A	Al	17.10	210
2	KH332-48SS	50	48	116	58	198	210	94.0	17	320	17	77.8	42.9	M12	20	219	-	442A	Al	24.60	210
2 1/2	KH340-63SS	65	63	150	75	198	259	94.0	20	600	16	88.9	50.8	M12	19	-	-	442A	St	35.50	175
3	KH348-76SS	80	76	150	79	218	284	104.0	26	600	19	106.4	61.9	M16	24	-	-	442A	St	40.00	160

*Please choose between KH320-32SS and KH320-32TM12SS according to needed connection thread M.
For 4" and 5" Ball valves see chapter Parflange® F37 - SAE 1000/ISO 6162-1 footprint.

Please change suffixes according to material/surface required

Order code suffixes		
Material	Suffix surface and material	Example
Stainless steel	SS	KH320-32SS

	Material 442A
Body	Stainless Steel
Ball	Stainless Steel
Stem	Stainless Steel
Ball seats	POM
O-Ring	NBR
Tmin / T max	-30°C / 100°C



KH-R – Ball valve with SAE 3000 Flanges

SAE 3000/ISO 6162-1

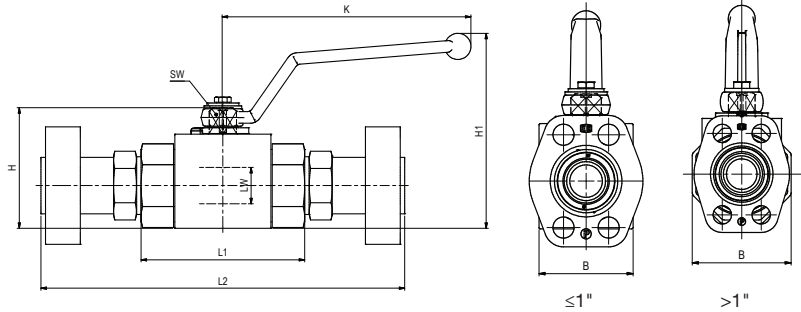
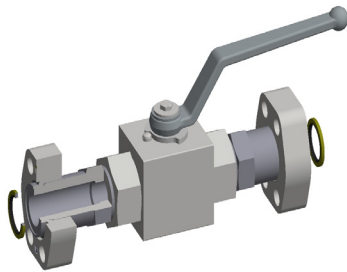

Material Steel

Size Inch	Complete part Order code	Valve body Order code	LW	L1	L2	B	H	SW	K	H1	Weight (Steel) kg/1 kit	W.P. bar
3/4	KH-R-312-20CF	KH-R-12-20CF	20	95	217	49	75	14	171	126	2.5	350
1	KH-R-316-25CF	KH-R-16-25CF	25	113	251	58	83	14	171	134	3.8	350
1 1/4	KH-R-320-32CF	KH-R-20-32CF	32	111	271	81	107	17	306	178	6.0	280
1 1/2	KH-R-324-38CF	KH-R-24-38CF	38	130	316	100	124	17	306	196	8.4	280
2	KH-R-332-48CF	KH-R-32-48CF	48	140	348	118	138	17	306	210	13.9	280

Other sizes on request.

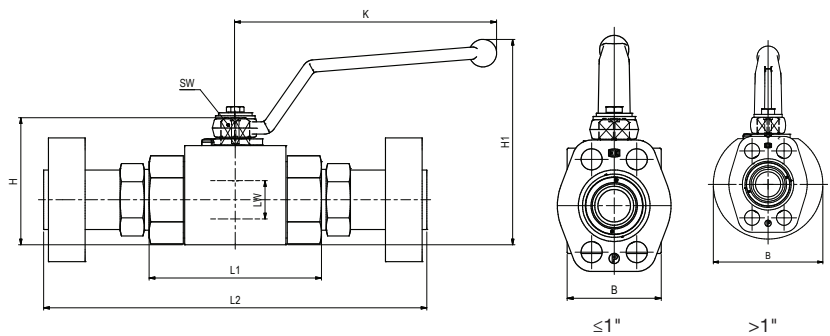
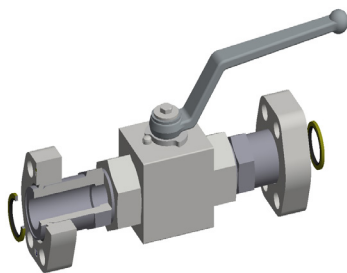

Material Stainless Steel

Size Inch	Complete part Order code	Valve body Order code	LW	L1	L2	B	H	SW	K	H1	Weight (Steel) kg/1 kit	W.P. bar
3/4	KH-R-312-20SS	KH-R-12-20SS	20	95	217	49	75	14	171	126	2.5	350
1	KH-R-316-25SS	KH-R-16-25SS	25	113	251	58	83	14	171	134	3.8	350
1 1/4	KH-R-320-32SS	KH-R-20-32SS	32	111	271	109	121	17	228	195	8.6	280
1 1/2	KH-R-324-38SS	KH-R-24-38SS	38	130	316	124	136	17	228	210	12.0	280
2	KH-R-332-48SS	KH-R-32-48SS	48	140	348	132	145	17	228	219	16.1	280

Other sizes on request.

Please change suffixes according to material/surface required

Order code suffixes			
Material	Suffix surface and material	Example	Comments
Steel, zinc plated, Cr(VI)-free	CF	KH-R-320-32CF	
Stainless steel	SS	KH-R-320-32SS	on request

	Material 112A	Material 442A
Body	Steel	Stainless Steel
Ball	Steel	Stainless Steel
Stem	Steel	Stainless Steel
Ball seats	POM	POM
O-Ring	NBR	NBR
Tmin / T max	-20°C / 100 °C	-30°C / 100°C

RHD-R – Non return valves

SAE 3000/ISO 6162-1

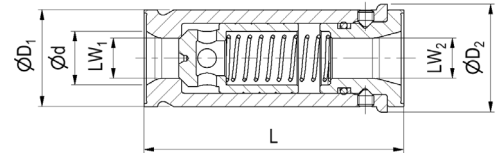
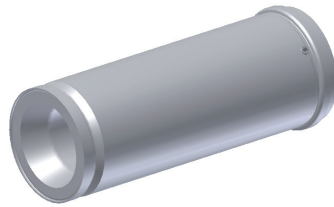

Size Inch	Complete part Order code	Valve body Order code	L	D1	D2	d	LW1	LW2	Weight body (Steel) kg/1 piece	W.P. bar
3/4	RHD-R-312-0.5BCF	RHD-R-12-0.5BCF	96.4	36	40.2	20.0	15	15.0	0.53	210
1	RHD-R-316-0.5BCF	RHD-R-16-0.5BCF	116.6	39	44.2	23.0	18	13.0	0.78	
1 1/4	RHD-R-320-0.5BCF	RHD-R-20-0.5BCF	135.6	46	51.1	30.0	20	17.0	1.26	
1 1/2	RHD-R-324-0.5BCF	RHD-R-24-0.5BCF	135.6	56	60.5	38.8	30	27.0	1.61	
2	RHD-R-332-0.5BCF	RHD-R-32-0.5BCF	180.1	66	70.5	49.0	40	36.4	2.54	
2 1/2	RHD-R-340-0.5BCF	RHD-R-40-0.5BCF	190.0	80	84.5	60.0	50	46.8	3.89	
3	RHD-R-348-0.5BCF	RHD-R-48-0.5BCF	200.0	97	103.2	73.0	63	62.8	5.90	

Opening pressure 0.5 bar. Other pressure rates on request.
 Complete Part = body + flanges + retaining rings + bonded seals.

Please change suffixes according to material/surface required

Order code suffixes		
Material	Suffix surface and material	Example
Steel, zinc plated, Cr(VI)-free	CF	RHD-R-320-0.5BCF
Stainless steel (inner parts steel)	SS	RHD-R-320-0.5BSS

	Materials
Body	Steel/Stainless Steel
Piston	Steel
O-Ring	NBR
Tmin / T max	-10°C / 100 °C



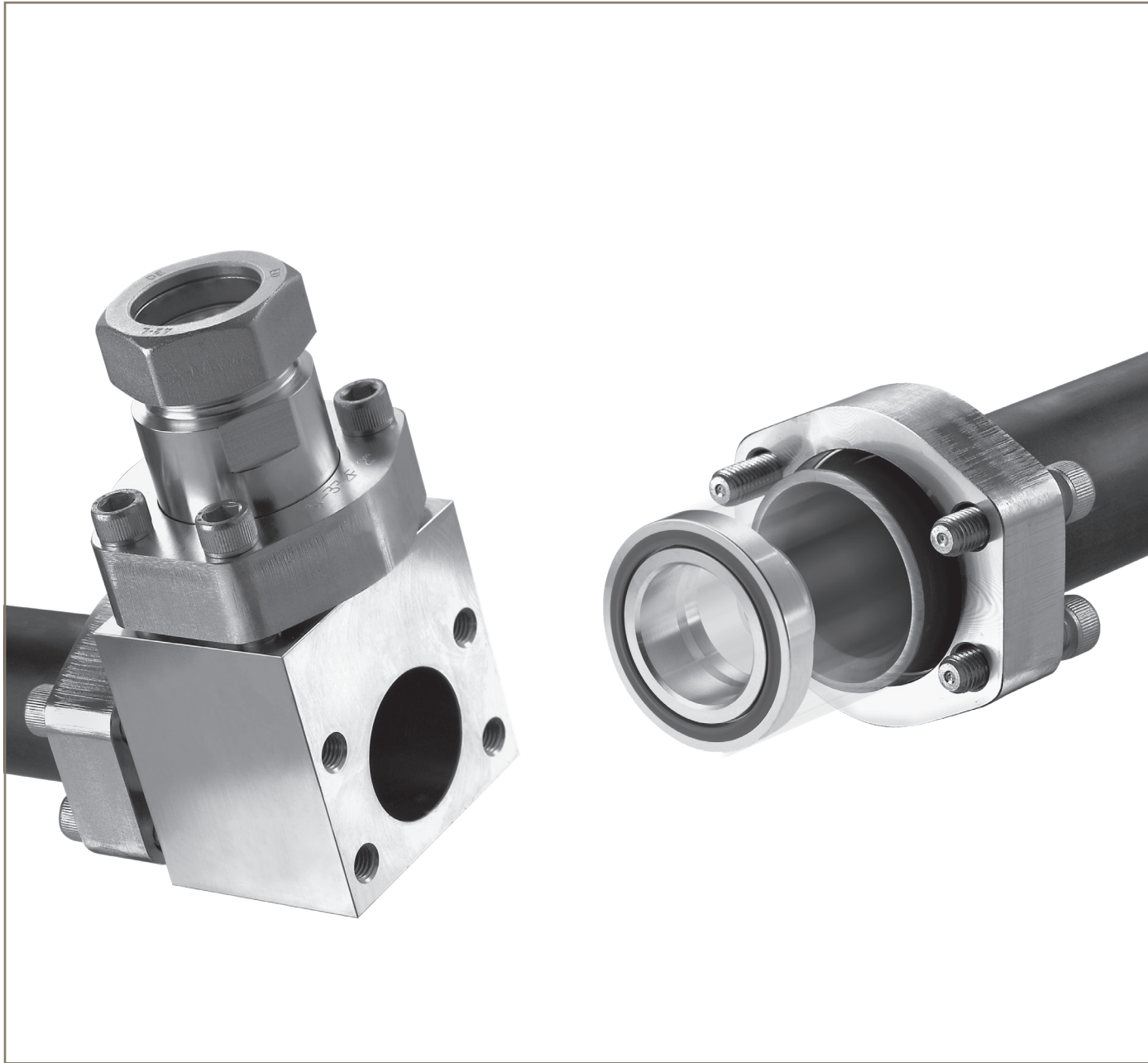









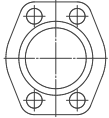
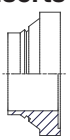
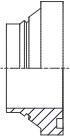
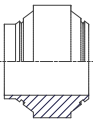

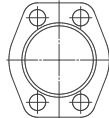

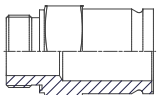
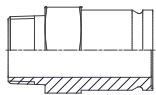

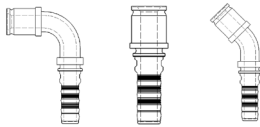
SAE 6000 System

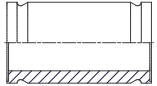
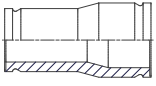
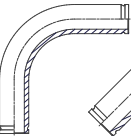
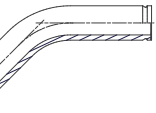
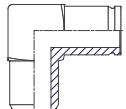
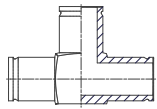
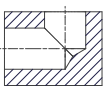
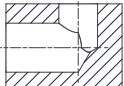
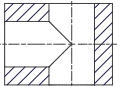
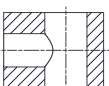
420 bar

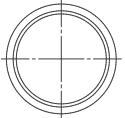
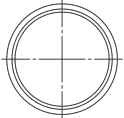
ENGINEERING YOUR SUCCESS.

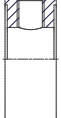
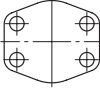
Programme overview SAE 6000/ISO 6162-2 footprint

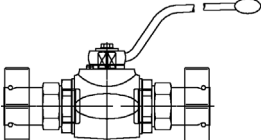
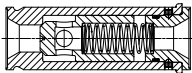
Parflange® F37 connection parts	Flanges  F37 – p.101/102							
	Inserts  TFB – p.105  TFV – p.106  TT – p.107  TF – p.108				Sleeve  SL – p.109			
Retaining ring connection parts	Flanges  R – p.103  R-Ring – p.108  PSC – p.104			Male / Female  MTF-R – p.111  MTF-N – p.112  FTF-R – p.113		Hose  Hose – p.114		Weld  WA – p.115/116
	Tube to Tube  BF – p.117  RF – p.118  FB90 – p.119/121  FB45 – p.120/122  LF – p.123  TF – p.124							
	SAE connection parts	Blocks  LB – p.125  LBR – p.126  TB – p.127  TBR – p.128  BFV – p.129						
Seals Adapter Bolts	Components  BS – p.130  F37S – p.130  AO – p.131  TBT – p.132  AP – p.133				Bolts and Nuts  <p>p.134</p>			
Ball valves	 KH – p.135/136  KH-R – p.137  RHD-R – p.138							

F37 – Flare flange | SAE 6000/ISO 6162-2 footprint

SAE 6000/ISO 6162-2

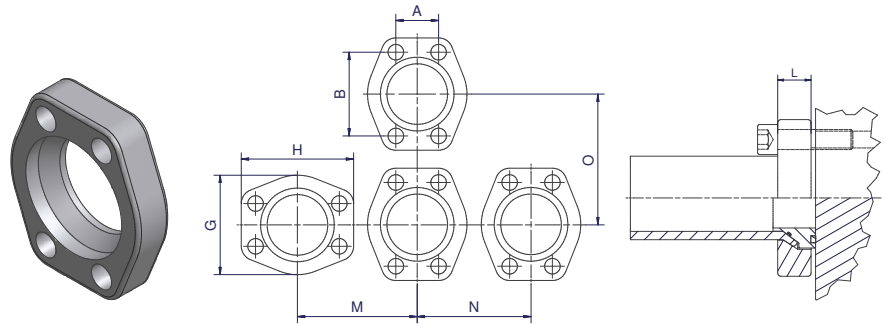

Parflange F37 flange dimensions

* Jump size flanges (no adapter sleeves (SL...) necessary).

Size Inch	Flange Order code	A	B	G	H	M	N	O	L	Weight body (Steel) kg/1 piece	W.P. bar
1/2	F37-608-CFX	18.2	40.5	48	56	57	53	61	20	0.20	420
3/4	F37-612-CFX	23.8	50.8	60	71	70	65	76	24	0.35	420
3/4	F37-612/25-CFX*	23.8	50.8	60	71	70	65	76	24	0.45	420
1	F37-616-CFX	27.8	57.2	70	81	80	75	86	24	0.53	420
1	F37-616/25-CFX*	27.8	57.2	70	81	80	75	86	24	0.64	420
1	F37-616/30-CFX*	27.8	57.2	70	81	80	75	86	24	0.59	420
1 1/4	F37-620-CFX	31.8	66.6	78	95	91	83	100	30	0.92	420
1 1/4	F37-620H12-CFX**	31.8	66.6	78	95	91	83	100	30	0.96	420
1 1/4	F37-620/38-CFX*	31.8	66.6	78	95	91	83	100	30	0.96	420
1 1/4	F37-620H12/38-CFX**	31.8	66.6	78	95	91	83	100	30	1.01	420
1 1/2	F37-624-CFX	36.5	79.3	95	112	109	100	118	35	1.54	420
1 1/2	F37-624/38-CFX*	36.5	79.3	95	112	109	100	118	35	1.74	420
1 1/2	F37-624/42-CFX*	36.5	79.3	95	112	109	100	118	35	1.72	420
2	F37-632-CFX	44.5	96.8	114	134	129	119	139	40	2.44	420
2	F37-632/50-CFX*	44.5	96.8	114	134	129	119	139	40	2.76	420
2 1/2	F37-64073-CFX*	58.7	123.8	150	175	169	156	183	50	6.26	420

**Flange for size M12 bolts.

Parflange F37 threaded flange dimensions

* Jump size flanges (no adapter sleeves (SL...) necessary).

Size Inch	Flange Order code	A	B	G	H	M	N	O	L	Thread	Weight body (Steel) kg/1 piece	W.P. bar
1/2	F37-608T-CFX	18.2	40.5	48	56	57	53	61	20	M08	0.20	420
3/4	F37-612T-CFX	23.8	50.8	60	71	70	65	76	24	M10	0.35	420
3/4	F37-612/25T-CFX	23.8	50.8	60	71	70	65	76	24	M10	0.49	420
1	F37-616T-CFX	27.8	57.2	70	81	80	75	86	24	M12	0.57	420
1	F37-616/25T-CFX*	27.8	57.2	70	81	80	75	86	24	M12	0.68	420
1	F37-616/30T-CFX*	27.8	57.2	70	81	80	75	86	24	M12	0.63	420
1 1/4	F37-620T-CFX	31.8	66.6	78	95	91	83	100	30	M14	0.92	420
1 1/4	F37-620TM12-CFX**	31.8	66.6	78	95	91	83	100	30	M12	1.01	420
1 1/4	F37-620/38T-CFX*	31.8	66.6	78	95	91	83	100	30	M14	1.03	420
1 1/4	F37-620TM12/38-CFX**	31.8	66.6	78	95	91	83	100	30	M12	1.06	420
1 1/2	F37-624T-CFX	36.5	79.3	95	112	109	100	118	35	M16	1.64	420
1 1/2	F37-624/38T-CFX*	36.5	79.3	95	112	109	100	118	35	M16	1.82	420
2	F37-632T-CFX	44.5	96.8	114	134	129	119	139	40	M20	2.44	420

**Flange for size M12 bolts.

Pressure rates related to flanges. Other sizes / jump sizes on request.

Please change suffixes according to material/surface required

Order code suffixes			
Material	Suffix surface and material	Example	Comments
Steel, zinc plated, Cr(VI)-free	CF	F37-620-CFX	
Stainless steel	SS	F37-620-SSX	
Galvanized hot dip zinc	TZN	F37-620-TZNX	on request

Parflange® F37 – SAE 6000/ISO 6162-2

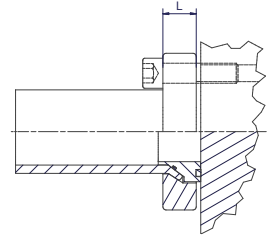
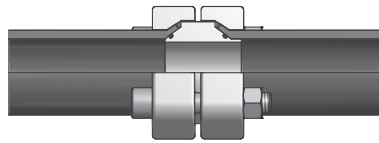

Part combination flaring SAE 6000

Flange Pressure (bar)	Size Inch	Pipe Size	Flange SAE 6000 ISO 6162-2	Insert*	Sleeve
420	1/2	16X2.0	F37-608-CFX	IN08-16X2.0T...	SL08-25-16-CFX
	1/2	18X2.0	F37-608-CFX	IN08-18X2.0T...	SL08-25-18-CFX
	1/2	20X2.0	F37-608-CFX	IN08-20X2.0T...	SL08-25-20-CFX
	1/2	20X2.5	F37-608-CFX	IN08-20X2.5T...	SL08-25-20-CFX
	1/2	25X2.5	F37-608-CFX	IN08-25X2.5T...	
	1/2	25X3.0	F37-608-CFX	IN08-25X3.0T...	
	3/4	20X2.0	F37-612-CFX	IN12-20X2.0T...	SL12-30-20-CFX
	3/4	20X2.5	F37-612-CFX	IN12-20X2.5T...	SL12-30-20-CFX
	3/4	25X2.5	F37-612-CFX	IN12-25X2.5T...	SL12-30-25-CFX**
	3/4	25X3.0	F37-612-CFX	IN12-25X3.0T...	SL12-30-25-CFX**
	3/4	30X3.0	F37-612-CFX	IN12-30X3.0T...	
	3/4	30X4.0	F37-612-CFX	IN12-30X4.0T...	
	1	25X2.5	F37-616-CFX	IN16-25X2.5T...	SL16-38-25-CFX**
	1	25X3.0	F37-616-CFX	IN16-25X3.0T...	SL16-38-25-CFX**
	1	30X3.0	F37-616-CFX	IN16-30X3.0T...	SL16-38-30-CFX**
	1	30X4.0	F37-616-CFX	IN16-30X4.0T...	SL16-38-30-CFX**
	1	38X2.5	F37-616-CFX	IN16-38X2.5T...	
	1	38X3.0	F37-616-CFX	IN16-38X3.0T...	
	1	38X4.0	F37-616-CFX	IN16-38X4.0T...	
	1	38X5.0	F37-616-CFX	IN16-38X5.0T...	
	1 1/4	30X3.0	F37-620-CFX***	IN20-30X3.0T...	SL20-42-30-CFX
	1 1/4	30X4.0	F37-620-CFX***	IN20-30X4.0T...	SL20-42-30-CFX
	1 1/4	38X3.0	F37-620-CFX***	IN20-38X3.0T...	SL20-42-38-CFX**
	1 1/4	38X4.0	F37-620-CFX***	IN20-38X4.0T...	SL20-42-38-CFX**
	1 1/4	38X5.0	F37-620-CFX***	IN20-38X5.0T...	SL20-42-38-CFX**
	1 1/4	42X3.0	F37-620-CFX***	IN20-42X3.0T...	
	1 1/4	42X4.0	F37-620-CFX***	IN20-42X4.0T...	
	1 1/2	38X3.0	F37-624-CFX	IN24-38X3.0T...	SL24-50-38-CFX**
	1 1/2	38X4.0	F37-624-CFX	IN24-38X4.0T...	SL24-50-38-CFX**
	1 1/2	38X5.0	F37-624-CFX	IN24-38X5.0T...	SL24-50-38-CFX**
1 1/2	42X3.0	F37-624-CFX	IN24-42X3.0T...	SL24-50-42-CFX**	
1 1/2	42X4.0	F37-624-CFX	IN24-42X4.0T...	SL24-50-42-CFX**	
1 1/2	50X3.0	F37-624-CFX	IN24-50X3.0T...		
1 1/2	50X5.0	F37-624-CFX	IN24-50X5.0T...		
1 1/2	50X6.0	F37-624-CFX	IN24-50X6.0T...		
2	50X3.0	F37-632-CFX	IN32-50X3.0T...	SL32-60-50-CFX**	
2	50X5.0	F37-632-CFX	IN32-50X5.0T...	SL32-60-50-CFX**	
2	50X6.0	F37-632-CFX	IN32-50X6.0T...	SL32-60-50-CFX**	
2	60X3.0	F37-632-CFX	IN32-60X3.0T...		
2	60X5.0	F37-632-CFX	IN32-60X5.0T...		
2	60X6.0	F37-632-CFX	IN32-60X6.0T...		

Select the complete version:

- * ...FBCF Bonded Seal version
- ...FVCF F37 Seal version
- ...TCF Tube to Tube version
- ...FCF Flat Face version

**Jump size flanges available alternatively to adapter sleeve, see page 109.

***Flanges for M12 bolts also available (F37-620H12-CFX).

Other sizes like schedule on request.

Bolts and nuts are not included in complete part numbers.

For recommended bolts and nuts see page 136.



R – Retaining ring flange | SAE 6000/ISO 6162-2 footprint

SAE 6000/ISO 6162-2

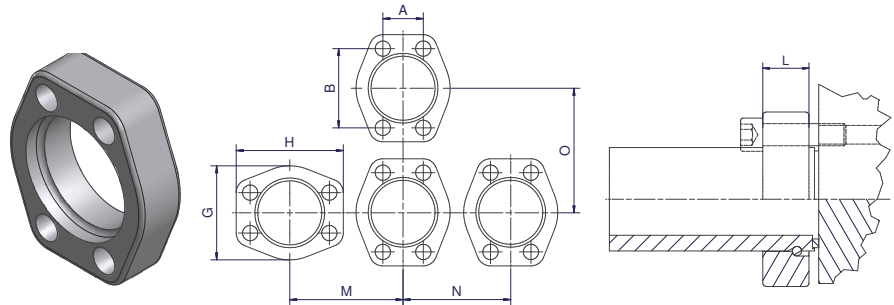

Retaining ring flange dimensions

Size Inch	Flange Order code	A	B	G	H	M	N	O	L	Weight body (Steel) kg/1 piece	W.P. bar
1/2	R-608-CFX	18.2	40.5	48	56	57	53	61	20	0.22	420
3/4	R-612-CFX	23.8	50.8	60	71	70	65	76	24	0.39	420
1	R-616-CFX	27.8	57.2	70	81	80	75	86	24	0.55	420
1 1/4	R-620-CFX	31.8	66.6	78	95	91	83	100	30	0.89	420
1 1/4	R-620H12-CFX*	31.8	66.6	78	95	91	83	100	30	0.92	420
1 1/2	R-624-CFX	36.5	79.3	95	112	109	100	118	35	1.46	420
2	R-632-CFX	44.5	96.8	114	134	129	119	139	40	2.35	420
2 1/2	R-640-CFX	58.7	123.8	150	176	169	156	183	50	5.96	420
3	R-648-CFX	71.4	152.4	176	212	202	184	218	52	8.41	420

*Flange for size M12 bolts.
 Pressure rates related to flanges.
 Other sizes like schedule on request.
 For all sizes also threaded flanges available (...T-CFX, R-620TM12-CFX).

Please change suffixes according to material/surface required

Order code suffixes			
Material	Suffix surface and material	Example	Comments
Steel, zinc plated, Cr(VI)-free	CF	R-620-CFX	
Stainless steel	SS	R-620-SSX	
Galvanized hot dip zinc	TZN	R-620-TZNX	on request

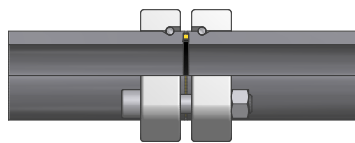

Part combination Bonded seal SAE 6000 connection

Flange pressure (bar)	Size Inch	Pipe Size	Flange	Retaining Ring	Bonded Seal
420	1/2	26X6.0	R-608-CFX	R08X	BS08SNX
	3/4	36X8.0	R-612-CFX	R12X	BS12SNX
	1	39X7.5	R-616-CFX	R16X	BS16SNX
	1 1/4	46X8.0	R-620-CFX	R20X	BS20SNX
	1 1/2	56X8.5	R-624-CFX	R24X	BS24SNX
	2	66X8.5	R-632-CFX	R32X	BS32SNX
	2 1/2	80X10.0	R-640-CFX	R40X	BS40SNX
	3	97X12.0	R-648-CFX	R48X	BS48SNX

For recommended bolts and nuts see page 136.

PSC – Pipe seal carrier | SAE 6000/ISO 6162-2 footprint

SAE 6000/ISO 6162-2

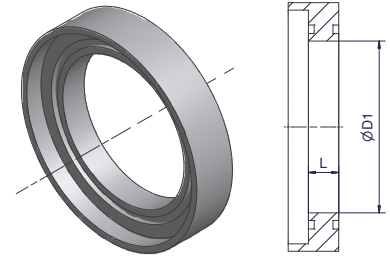

Size Inch	Pipe size	Seal carrier incl. F37 Seal	Seal carrier incl. O-Ring	L	D1	F37 Seal	O-Ring
1 1/4	46X8.0	PSC20-46X8.0VCF	PSC20-46X8.0OCF	8.0	30	F37RS20X	OR34.59X2.62X
1 1/2	56X8.5	PSC24-56X8.5VCF	PSC24-56X8.5OCF	10.0	39	F37RS24X	OR44.12X2.62X
2	66X8.5	PSC32-66X8.5VCF	PSC32-66X8.5OCF	10.0	49	F37RS32X	OR55.25X2.62X
2 1/2	80X10.0	PSC40-80X10VCF	PSC40-80X10OCF	15.0	60	F37RS40X	OR66.27X3.53X
3	97X12.0	PSC48-97X12VCF	PSC48-97X12OCF	15.0	73	F37RS48X	OR78.97X3.53X

Other sizes on request.

Please change suffixes according to material/surface required

Order code suffixes		
Material	Suffix surface and material	Example
Steel, zinc plated, Cr(VI)-free, F37-Seal	VCF	PSC40-80X10VCF
Stainless steel, F37-Seal	VSS	PSC40-80X10VSS
Steel, zinc plated, Cr(VI)-free, O-Ring (NBR)	OCF	PSC40-80X10OCF
Stainless steel, O-Ring (NBR)	OSS	PSC40-80X10OSS

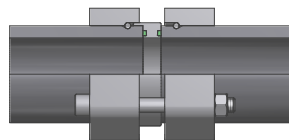

Example of Part combination Pipe seal carrier SAE 6000 connection

Flange pressure (bar)	Size Inch	Pipe Size	Flange	Retaining Ring	Seal Carrier
420	1 1/4	46X8.0	R-620-CFX or R-620H12-CFX	R20X	PSC20-46X8.0VCF
	1 1/2	56X8.5	R-624-CFX	R24X	PSC24-56X8.5VCF
	2	66X8.5	R-632-CFX	R32X	PSC32-66X8.5VCF
	2 1/2	80X10.0	R-640-CFX	R40X	PSC40-80X10VCF
	3	97X12.0	R-648-CFX	R48X	PSC48-97X12VCF

Other sizes on request.

Bolts and nuts are not included in complete part numbers. For recommended bolts and nuts see page 136.



TFB – Flare flange connection

Tube to port connection, bonded seal

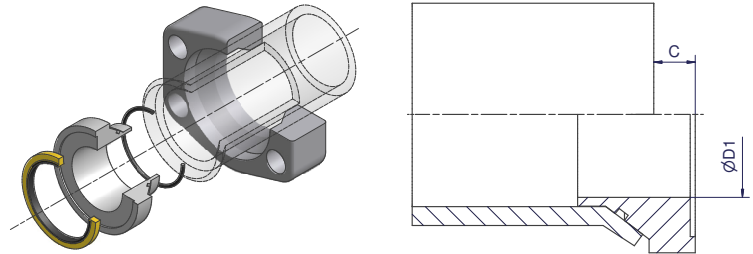

Size		Flange* incl. Insert + Bonded Seal + O-Ring Order code	D1	C	Insert incl. Bonded Seal + O-Ring Order code	Bonded Seal Order code	O-Ring Order code	Weight (Steel) kg/1 kit
Inch	Tube							
1/2	16X2.0	F37-608-16X2.0TFBCF	9.5	8.0	IN08-16X2.0TFBCF	BS08SNX	OR12X1.0X	0.24
1/2	18X2.0	F37-608-18X2.0TFBCF	11.5	8.0	IN08-18X2.0TFBCF	BS08SNX	OR14X1.0X	0.24
1/2	20X2.0	F37-608-20X2.0TFBCF	13.5	8.0	IN08-20X2.0TFBCF	BS08SNX	OR16X1.0X	0.24
1/2	20X2.5	F37-608-20x2.5TFBCF	13.5	8.0	IN08-20X2.5TFBCF	BS08SNX	OR16X1.0X	0.24
1/2	25X2.5	F37-608-25X2.5TFBCF	13.5	10.0	IN08-25X2.5TFBCF	BS08SNX	OR20X1.0X	0.25
1/2	25X3.0	F37-608-25X3.0TFBCF	13.0	8.0	IN08-25X3.0TFBCF	BS08SNX	OR20X1.0X	0.24
3/4	20X2.0	F37-612-20X2.0TFBCF	13.5	8.0	IN12-20X2.0TFBCF	BS12SNX	OR16X1.0X	0.41
3/4	20X2.5	F37-612-20X2.5TFBCF	12.5	8.0	IN12-20X2.5TFBCF	BS12SNX	OR16X1.0X	0.41
3/4	25X2.5	F37-612-25X2.5TFBCF	17.5	10.0	IN12-25X2.5TFBCF	BS12SNX	OR20X1.0X	0.41
3/4	25X3.0	F37-612-25X3.0TFBCF	16.5	8.0	IN12-25X3.0TFBCF	BS12SNX	OR20X1.0X	0.42
3/4	30X3.0	F37-612-30X3.0TFBCF	19.0	8.5	IN12-30X3.0TFBCF	BS12SNX	OR25X1.0X	0.42
3/4	30X4.0	F37-612-30X4.0TFBCF	19.5	8.5	IN12-30X4.0TFBCF	BS12SNX	OR22X1.0X	0.42
1	25X2.5	F37-616-25X2.5TFBCF	17.5	10.0	IN16-25X2.5TFBCF	BS16SNX	OR20X1.0X	0.62
1	25X3.0	F37-616-25X3.0TFBCF	16.5	8.0	IN16-25X3.0TFBCF	BS16SNX	OR20X1.0X	0.62
1	30X3.0	F37-616-30X3.0TFBCF	21.5	8.5	IN16-30X3.0TFBCF	BS16SNX	OR25X1.0X	0.62
1	30X4.0	F37-616-30X4.0TFBCF	19.5	8.5	IN16-30X4.0TFBCF	BS16SNX	OR22X1.0X	0.62
1	38X2.5	F37-616-38X2.5TFBCF	25.0	9.5	IN16-38X2.5TFBCF	BS16SNX	OR34X1.0X	0.64
1	38X3.0	F37-616-38X3.0TFBCF	25.0	9.0	IN16-38X3.0TFBCF	BS16SNX	OR34X1.0X	0.63
1	38X4.0	F37-616-38X4.0TFBCF	25.0	10.0	IN16-38X4.0TFBCF	BS16SNX	OR30X1.0X	0.63
1	38X5.0	F37-616-38X5.0TFBCF	25.0	8.0	IN16-38X5.0TFBCF	BS16SNX	OR28X1.0X	0.62
1 1/4	30X3.0	F37-620-30X3.0TFBCF**	21.5	8.5	IN20-30X3.0TFBCF	BS20SNX	OR25X1.0X	1.03
1 1/4	30X4.0	F37-620-30X4.0TFBCF**	19.5	8.5	IN20-30X4.0TFBCF	BS20SNX	OR22X1.0X	1.04
1 1/4	38X3.0	F37-620-38X3.0TFBCF**	29.5	9.0	IN20-38X3.0TFBCF	BS20SNX	OR34X1.0X	1.02
1 1/4	38X4.0	F37-620-38X4.0TFBCF**	27.0	10.0	IN20-38X4.0TFBCF	BS20SNX	OR30X1.0X	1.03
1 1/4	38X5.0	F37-620-38X5.0TFBCF**	25.5	8.0	IN20-38X5.0TFBCF	BS20SNX	OR28X1.0X	1.02
1 1/4	42X3.0	F37-620-42X3.0TFBCF**	31.5	10.0	IN20-42X3.0TFBCF	BS20SNX	OR37.82X1.78X	1.03
1 1/4	42X4.0	F37-620-42X4.0TFBCF**	31.5	10.0	IN20-42X4.0TFBCF	BS20SNX	OR34X1.0X	1.02
1 1/2	38X3.0	F37-624-38X3.0TFBCF	27.5	9.0	IN24-38X3.0TFBCF	BS24SNX	OR34X1.0X	1.11
1 1/2	38X4.0	F37-624-38X4.0TFBCF	27.5	10.0	IN24-38X4.0TFBCF	BS24SNX	OR30X1.0X	1.73
1 1/2	38X5.0	F37-624-38X5.0TFBCF	25.0	11.0	IN24-38X5.0TFBCF	BS24SNX	OR28X1.0X	1.73
1 1/2	42X3.0	F37-624-42X3.0TFBCF	35.0	10.0	IN24-42X3.0TFBCF	BS24SNX	OR37.82X1.78X	1.74
1 1/2	42X4.0	F37-624-42X4.0TFBCF	31.5	10.0	IN24-42X4.0TFBCF	BS24SNX	OR34X1.0X	1.73
1 1/2	50X3.0	F37-624-50X3.0TFBCF	36.0	11.0	IN24-50X3.0TFBCF	BS24SNX	OR44.17X1.78X	1.73
1 1/2	50X5.0	F37-624-50X5.0TFBCF	36.0	10.0	IN24-50X5.0TFBCF	BS24SNX	OR41X1.78X	1.73
1 1/2	50X6.0	F37-624-50X6.0TFBCF	35.0	10.0	IN24-50X6.0TFBCF	BS24SNX	OR41X1.78X	1.73
2	50X3.0	F37-632-50X3.0TFBCF	41.5	11.0	IN32-50X3.0TFBCF	BS32SNX	OR44.17X1.78X	2.66
2	50X5.0	F37-632-50X5.0TFBCF	37.5	10.0	IN32-50X5.0TFBCF	BS32SNX	OR41X1.78X	2.68
2	50X6.0	F37-632-50X6.0TFBCF	35.0	10.0	IN32-50X6.0TFBCF	BS32SNX	OR41X1.78X	2.71
2	60X3.0	F37-632-60X3.0TFBCF	46.0	12.0	IN32-60X3.0TFBCF	BS32SNX	OR53.7X1.78X	2.71
2	60X5.0	F37-632-60X5.0TFBCF	46.0	11.0	IN32-60X5.0TFBCF	BS32SNX	OR50.52X1.78X	2.68
2	60X6.0	F37-632-60X6.0TFBCF	45.5	11.0	IN32-60X6.0TFBCF	BS32SNX	OR47.37X1.78X	2.67

**Flanges for M12 bolts also available (F37-620H12-...TFBCF).
Other sizes on request. *Incl. adapter sleeve or jump size flange if necessary.
Please change suffixes according to material/surface required

Order code suffixes		
Material	Suffix surface and material	Example
Steel, zinc plated, Cr(VI)-free	CF	F37-624-50X5.0TFBCF
Stainless steel	SS	F37-624-50X5.0TFBSS

TFV – Flare flange connection

Tube to port connection, F37 seal

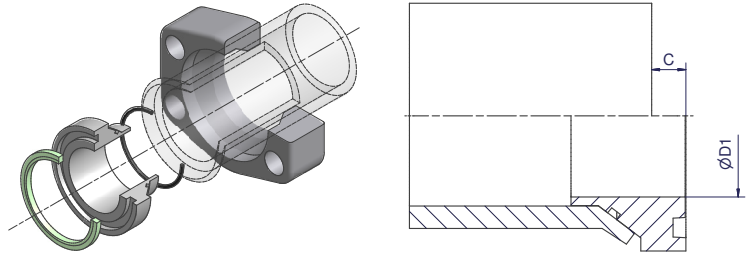

Size		Flange* incl. Insert + F37 Seal + O-Ring Order code	D1	C	Insert incl. F37 Seal + O-Ring Order code	F37 Seal Order code	O-Ring Order code	Weight (Steel) kg/1 kit
Inch	Tube							
1/2	16X2.0	F37-608-16X2.0TFVCF	9.5	8.0	IN08-16X2.0TFVCF	F37S08X	OR12X1.0X	0.24
1/2	18X2.0	F37-608-18X2.0TFVCF	11.5	8.0	IN08-18X2.0TFVCF	F37S08X	OR14X1.0X	0.24
1/2	20X2.0	F37-608-20X2.0TFVCF	13.5	8.0	IN08-20X2.0TFVCF	F37S08X	OR16X1.0X	0.24
1/2	20X2.5	F37-608-20X2.5TFVCF	13.5	8.0	IN08-20X2.5TFVCF	F37S08X	OR16X1.0X	0.24
1/2	25X2.5	F37-608-25X2.5TFVCF	13.5	10.0	IN08-25X2.5TFVCF	F37S08X	OR20X1.0X	0.25
1/2	25X3.0	F37-608-25X3.0TFVCF	13.0	8.0	IN08-25X3.0TFVCF	F37S08X	OR20X1.0X	0.24
3/4	20X2.0	F37-612-20X2.0TFVCF	13.5	8.0	IN12-20X2.0TFVCF	F37S12X	OR16X1.0X	0.41
3/4	20X2.5	F37-612-20X2.5TFVCF	12.5	8.0	IN12-20X2.5TFVCF	F37S12X	OR16X1.0X	0.41
3/4	25X2.5	F37-612-25X2.5TFVCF	17.5	10.0	IN12-25X2.5TFVCF	F37S12X	OR20X1.0X	0.41
3/4	25X3.0	F37-612-25X3.0TFVCF	16.5	8.0	IN12-25X3.0TFVCF	F37S12X	OR20X1.0X	0.42
3/4	30X3.0	F37-612-30X3.0TFVCF	19.0	8.5	IN12-30X3.0TFVCF	F37S12X	OR25X1.0X	0.42
3/4	30X4.0	F37-612-30X4.0TFVCF	19.5	8.5	IN12-30X4.0TFVCF	F37S12X	OR22X1.0X	0.42
1	25X2.5	F37-616-25X2.5TFVCF	17.5	10.0	IN16-25X2.5TFVCF	F37S16X	OR20X1.0X	0.61
1	25X3.0	F37-616-25X3.0TFVCF	16.5	8.0	IN16-25X3.0TFVCF	F37S16X	OR20X1.0X	0.62
1	30X3.0	F37-616-30X3.0TFVCF	21.5	8.5	IN16-30X3.0TFVCF	F37S16X	OR25X1.0X	0.64
1	30X4.0	F37-616-30X4.0TFVCF	19.5	8.5	IN16-30X4.0TFVCF	F37S16X	OR22X1.0X	0.62
1	38X2.5	F37-616-38X2.5TFVCF	25.0	9.5	IN16-38X2.5TFVCF	F37S16X	OR34X1.0X	0.64
1	38X3.0	F37-616-38X3.0TFVCF	25.0	9.0	IN16-38X3.0TFVCF	F37S16X	OR34X1.0X	0.63
1	38X4.0	F37-616-38X4.0TFVCF	25.0	10.0	IN16-38X4.0TFVCF	F37S16X	OR30X1.0X	0.63
1	38X5.0	F37-616-38X5.0TFVCF	25.0	8.0	IN16-38X5.0TFVCF	F37S16X	OR28X1.0X	0.62
1 1/4	30X3.0	F37-620-30X3.0TFVCF**	21.5	8.5	IN20-30X3.0TFVCF	F37S20X	OR25X1.0X	1.03
1 1/4	30X4.0	F37-620-30X4.0TFVCF**	19.5	8.5	IN20-30X4.0TFVCF	F37S20X	OR22X1.0X	1.04
1 1/4	38X3.0	F37-620-38X3.0TFVCF**	29.5	9.0	IN20-38X3.0TFVCF	F37S20X	OR34X1.0X	1.02
1 1/4	38X4.0	F37-620-38X4.0TFVCF**	27.0	10.0	IN20-38X4.0TFVCF	F37S20X	OR30X1.0X	1.03
1 1/4	38X5.0	F37-620-38X5.0TFVCF**	25.5	8.0	IN20-38X5.0TFVCF	F37S20X	OR28X1.0X	1.02
1 1/4	42X3.0	F37-620-42X3.0TFVCF**	31.5	10.0	IN20-42X3.0TFVCF	F37S20X	OR37.82X1.78X	1.03
1 1/4	42X4.0	F37-620-42X4.0TFVCF**	31.5	10.0	IN20-42X4.0TFVCF	F37S20X	OR34X1.0X	1.02
1 1/2	38X3.0	F37-624-38X3.0TFVCF	27.5	9.0	IN24-38X3.0TFVCF	F37S24X	OR34X1.0X	1.73
1 1/2	38X4.0	F37-624-38X4.0TFVCF	27.5	10.0	IN24-38X4.0TFVCF	F37S24X	OR30X1.0X	1.73
1 1/2	38X5.0	F37-624-38X5.0TFVCF	25.0	11.0	IN24-38X5.0TFVCF	F37S24X	OR28X1.0X	1.73
1 1/2	42X3.0	F37-624-42X3.0TFVCF	33.5	10.0	IN24-42X3.0TFVCF	F37S24X	OR37.82X1.78X	1.73
1 1/2	42X4.0	F37-624-42X4.0TFVCF	31.5	10.0	IN24-42X4.0TFVCF	F37S24X	OR34X1.0X	1.73
1 1/2	50X3.0	F37-624-50X3.0TFVCF	36.0	11.0	IN24-50X3.0TFVCF	F37S24X	OR44.17X1.78X	1.73
1 1/2	50X5.0	F37-624-50X5.0TFVCF	36.0	10.0	IN24-50X5.0TFVCF	F37S24X	OR41X1.78X	1.73
1 1/2	50X6.0	F37-624-50X6.0TFVCF	35.0	10.0	IN24-50X6.0TFVCF	F37S24X	OR41X1.78X	1.73
2	50X3.0	F37-632-50X3.0TFVCF	41.5	11.0	IN32-50X3.0TFVCF	F37S32X	OR44.17X1.78X	2.66
2	50X5.0	F37-632-50X5.0TFVCF	37.5	10.0	IN32-50X5.0TFVCF	F37S32X	OR41X1.78X	2.68
2	50X6.0	F37-632-50X6.0TFVCF	35.0	10.0	IN32-50X6.0TFVCF	F37S32X	OR41X1.78X	2.71
2	60X3.0	F37-632-60X3.0TFVCF	46.0	12.0	IN32-60X3.0TFVCF	F37S32X	OR53.7X1.78X	2.71
2	60X5.0	F37-632-60X5.0TFVCF	46.0	11.0	IN32-60X5.0TFVCF	F37S32X	OR50.52X1.78X	2.68
2	60X6.0	F37-632-60X6.0TFVCF	45.5	11.0	IN32-60X6.0TFVCF	F37S32X	OR47.37X1.78X	2.67

**Flanges for M12 bolts also available (F37-620H12-...TFVCF).
Other sizes on request. *Incl. adapter sleeve or jump size flange if necessary.

Please change suffixes according to material/surface required

Order code suffixes		
Material	Suffix surface and material	Example
Steel, zinc plated, Cr(VI)-free	CF	F37-624-50X5.0TFVCF
Stainless steel	SS	F37-624-50X5.0TFVSS



TT – Flare flange connection

Tube to tube connection

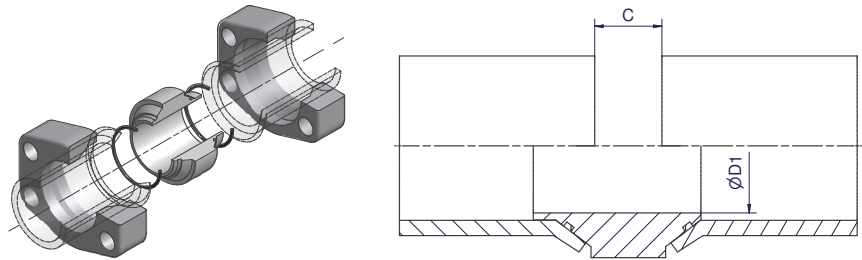

Size		2 x Flanges* incl. Insert + 2 x O-Ring Order code	D1	C	Insert incl. 2 x O-Ring Order code	O-Ring Order code	Weight (Steel) kg/1 kit
Inch	Tube						
1/2	16X2.0	F37-608-16X2.0TTCF	9.5	16	IN08-16X2.0TTCF	OR12X1.0X	0.28
1/2	18X2.0	F37-608-18X2.0TTCF	11.5	16	IN08-18X2.0TTCF	OR14X1.0X	0.29
1/2	20X2.0	F37-608-20X2.0TTCF	13.5	16	IN08-20X2.0TTCF	OR16X1.0X	0.29
1/2	20X2.5	F37-608-20X2.5TTCF	13.5	16	IN08-20X2.5TTCF	OR16X1.0X	0.29
1/2	25X2.5	F37-608-25X2.5TTCF	13.5	20	IN08-25X2.5TTCF	OR20X1.0X	0.30
1/2	25X3.0	F37-608-25X3.0TTCF	13.5	16	IN08-25X3.0TTCF	OR20X1.0X	0.29
3/4	20X2.0	F37-612-20X2.0TTCF	13.5	16	IN12-20X2.0TTCF	OR16X1.0X	0.48
3/4	20X2.5	F37-612-20X2.5TTCF	12.5	16	IN12-20X2.5TTCF	OR16X1.0X	0.48
3/4	25X2.5	F37-612-25X2.5TTCF	17.5	20	IN12-25X2.5TTCF	OR20X1.0X	0.49
3/4	25X3.0	F37-612-25X3.0TTCF	16.5	16	IN12-25X3.0TTCF	OR20X1.0X	0.49
3/4	30X3.0	F37-612-30X3.0TTCF	19.0	17	IN12-30X3.0TTCF	OR25X1.0X	0.50
3/4	30X4.0	F37-612-30X4.0TTCF	19.5	17	IN12-30X4.0TTCF	OR22X1.0X	0.50
1	25X2.5	F37-616-25X2.5TTCF	17.5	20	IN16-25X2.5TTCF	OR20X1.0X	0.72
1	25X3.0	F37-616-25X3.0TTCF	16.5	16	IN16-25X3.0TTCF	OR20X1.0X	0.72
1	30X3.0	F37-616-30X3.0TTCF	21.5	17	IN16-30X3.0TTCF	OR25X1.0X	0.71
1	30X4.0	F37-616-30X4.0TTCF	19.5	17	IN16-30X4.0TTCF	OR22X1.0X	0.72
1	38X2.5	F37-616-38X2.5TTCF	25.0	19	IN16-38X2.5TTCF	OR34X1.0X	0.77
1	38X3.0	F37-616-38X3.0TTCF	25.0	18	IN16-38X3.0TTCF	OR34X1.0X	0.75
1	38X4.0	F37-616-38X4.0TTCF	25.0	20	IN16-38X4.0TTCF	OR30X1.0X	0.73
1	38X5.0	F37-616-38X5.0TTCF	25.0	16	IN16-38X5.0TTCF	OR28X1.0X	0.71
1 1/4	30X3.0	F37-620-30X3.0TTCF**	21.5	17	IN20-30X3.0TTCF	OR25X1.0X	1.16
1 1/4	30X4.0	F37-620-30X4.0TTCF**	19.5	17	IN20-30X4.0TTCF	OR22X1.0X	1.19
1 1/4	38X3.0	F37-620-38X3.0TTCF**	25.0	18	IN20-38X3.0TTCF	OR34X1.0X	1.14
1 1/4	38X4.0	F37-620-38X4.0TTCF**	27.0	20	IN20-38X4.0TTCF	OR30X1.0X	1.15
1 1/4	38X5.0	F37-620-38X5.0TTCF**	25.5	16	IN20-38X5.0TTCF	OR28X1.0X	1.13
1 1/4	42X3.0	F37-620-42X3.0TTCF**	31.5	20	IN20-42X3.0TTCF	OR37.82X1.78X	1.14
1 1/4	42X4.0	F37-620-42X4.0TTCF**	31.5	20	IN20-42X4.0TTCF	OR34X1.0X	1.13
1 1/2	38X3.0	F37-624-38X3.0TTCF	27.5	18	IN24-38X3.0TTCF	OR34X1.0X	1.79
1 1/2	38X4.0	F37-624-38X4.0TTCF	27.5	20	IN24-38X4.0TTCF	OR30X1.0X	1.79
1 1/2	38X5.0	F37-624-38X5.0TTCF	25.0	22	IN24-38X5.0TTCF	OR28X1.0X	1.79
1 1/2	42X3.0	F37-624-42X3.0TTCF	33.5	20	IN24-42X3.0TTCF	OR37.82X1.78X	1.84
1 1/2	42X4.0	F37-624-42X4.0TTCF	31.5	20	IN24-42X4.0TTCF	OR34X1.0X	1.94
1 1/2	50X3.0	F37-624-50X3.0TTCF	36.0	22	IN24-50X3.0TTCF	OR44.17X1.78X	1.96
1 1/2	50X5.0	F37-624-50X5.0TTCF	36.0	20	IN24-50X5.0TTCF	OR41X1.78X	2.07
1 1/2	50X6.0	F37-624-50X6.0TTCF	35.0	20	IN24-50X6.0TTCF	OR41X1.78X	1.96
2	50X3.0	F37-632-50X3.0TTCF	41.5	22	IN32-50X3.0TTCF	OR44.17X1.78X	2.86
2	50X5.0	F37-632-50X5.0TTCF	37.5	20	IN32-50X5.0TTCF	OR41X1.78X	2.97
2	50X6.0	F37-632-50X6.0TTCF	35.0	20	IN32-50X6.0TTCF	OR41X1.78X	3.02
2	60X3.0	F37-632-60X3.0TTCF	46.0	24	IN32-60X3.0TTCF	OR53.7X1.78X	2.99
2	60X5.0	F37-632-60X5.0TTCF	46.0	22	IN32-60X5.0TTCF	OR50.52X1.78X	2.92
2	60X6.0	F37-632-60X6.0TTCF	45.5	22	IN32-60X6.0TTCF	OR47.37X1.78X	2.91

**Flanges for M12 bolts also available (F37-620H12-...TTCF).
Other sizes on request. *Incl. adapter sleeve or jump size flange if necessary.
Please change suffixes according to material/surface required

Order code suffixes		
Material	Suffix surface and material	Example
Steel, zinc plated, Cr(VI)-free	CF	F37-624-50X5.0TTCF
Stainless steel	SS	F37-624-50X5.0TTSS

TF – Flare flange connection

Tube to port connection, flat face

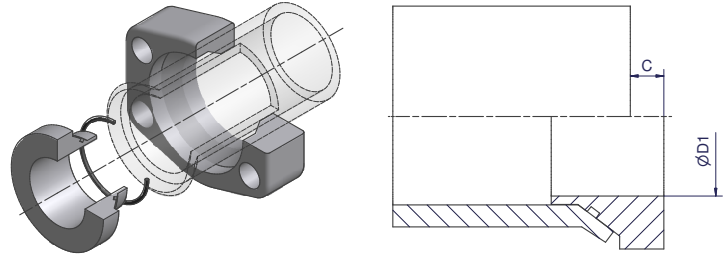

Size		Flange* incl. Insert + O-Ring Order code	D1	C	Insert incl. O-Ring Order code	O-Ring Order code	Weight (Steel) kg/1 kit
Inch	Tube						
1/2	16X2.0	F37-608-16X2.0TFCF	9.5	8.0	IN08-16X2.0TFCF	OR12X1.0X	0.24
1/2	18X2.0	F37-608-18X2.0TFCF	11.5	8.0	IN08-18X2.0TFCF	OR14X1.0X	0.24
1/2	20X2.0	F37-608-20X2.0TFCF	13.5	8.0	IN08-20X2.0TFCF	OR16X1.0X	0.25
1/2	20X2.5	F37-608-20X2.5TFCF	13.5	8.0	IN08-20X2.5TFCF	OR16X1.0X	0.25
1/2	25X2.5	F37-608-25X2.5TFCF	13.5	10.0	IN08-25X2.5TFCF	OR20X1.0X	0.25
1/2	25X3.0	F37-608-25X3.0TFCF	13.0	8.0	IN08-25X3.0TFCF	OR20X1.0X	0.24
3/4	20X2.0	F37-612-20X2.0TFCF	13.5	8.0	IN12-20X2.0TFCF	OR16X1.0X	0.41
3/4	20X2.5	F37-612-20X2.5TFCF	12.5	8.0	IN12-20X2.5TFCF	OR16X1.0X	0.41
3/4	25X2.5	F37-612-25X2.5TFCF	17.5	10.0	IN12-25X2.5TFCF	OR20X1.0X	0.41
3/4	25X3.0	F37-612-25X3.0TFCF	16.5	8.0	IN12-25X3.0TFCF	OR20X1.0X	0.42
3/4	30X3.0	F37-612-30X3.0TFCF	19.0	8.5	IN12-30X3.0TFCF	OR25X1.0X	0.42
3/4	30X4.0	F37-612-30X4.0TFCF	19.5	8.5	IN12-30X4.0TFCF	OR22X1.0X	0.42
1	25X2.5	F37-616-25X2.5TFCF	17.5	10.0	IN16-25X2.5TFCF	OR20X1.0X	0.61
1	25X3.0	F37-616-25X3.0TFCF	16.5	8.0	IN16-25X3.0TFCF	OR20X1.0X	0.62
1	30X3.0	F37-616-30X3.0TFCF	21.5	8.5	IN16-30X3.0TFCF	OR25X1.0X	0.64
1	30X4.0	F37-616-30X4.0TFCF	19.5	8.5	IN16-30X4.0TFCF	OR22X1.0X	0.62
1	38X2.5	F37-616-38X2.5TFCF	25.0	9.5	IN16-38X2.5TFCF	OR34X1.0X	0.64
1	38X3.0	F37-616-38X3.0TFCF	25.0	9.0	IN16-38X3.0TFCF	OR34X1.0X	0.63
1	38X4.0	F37-616-38X4.0TFCF	25.0	10.0	IN16-38X4.0TFCF	OR30X1.0X	0.63
1	38X5.0	F37-616-38X5.0TFCF	25.0	8.0	IN16-38X5.0TFCF	OR28X1.0X	0.62
1 1/4	30X3.0	F37-620-30X3.0TFCF**	21.5	8.5	IN20-30X3.0TFCF	OR25X1.0X	1.03
1 1/4	30X4.0	F37-620-30X4.0TFCF**	19.5	8.5	IN20-30X4.0TFCF	OR22X1.0X	1.05
1 1/4	38X3.0	F37-620-38X3.0TFCF**	29.0	9.0	IN20-38X3.0TFCF	OR34X1.0X	1.02
1 1/4	38X4.0	F37-620-38X4.0TFCF**	27.0	10.0	IN20-38X4.0TFCF	OR30X1.0X	1.03
1 1/4	38X5.0	F37-620-38X5.0TFCF**	25.5	8.0	IN20-38X5.0TFCF	OR28X1.0X	1.02
1 1/4	42X3.0	F37-620-42X3.0TFCF**	31.5	10.0	IN20-42X3.0TFCF	OR37.82X1.78X	1.03
1 1/4	42X4.0	F37-620-42X4.0TFCF**	31.5	10.0	IN20-42X4.0TFCF	OR34X1.0X	1.02
1 1/2	38X3.0	F37-624-38X3.0TFCF	27.5	9.0	IN24-38X3.0TFCF	OR34X1.0X	1.73
1 1/2	38X4.0	F37-624-38X4.0TFCF	27.5	10.0	IN24-38X4.0TFCF	OR30X1.0X	1.73
1 1/2	38X5.0	F37-624-38X5.0TFCF	25.0	11.0	IN24-38X5.0TFCF	OR28X1.0X	1.73
1 1/2	42X3.0	F37-624-42X3.0TFCF	33.5	10.0	IN24-42X3.0TFCF	OR37.82X1.78X	1.73
1 1/2	42X4.0	F37-624-42X4.0TFCF	31.5	10.0	IN24-42X4.0TFCF	OR34X1.0X	1.73
1 1/2	50X3.0	F37-624-50X3.0TFCF	36.0	11.0	IN24-50X3.0TFCF	OR44.17X1.78X	1.73
1 1/2	50X5.0	F37-624-50X5.0TFCF	36.0	10.0	IN24-50X5.0TFCF	OR41X1.78X	1.73
1 1/2	50X6.0	F37-624-50X6.0TFCF	35.0	10.0	IN24-50X6.0TFCF	OR41X1.78X	1.73
2	50X3.0	F37-632-50X3.0TFCF	41.5	11.0	IN32-50X3.0TFCF	OR44.17X1.78X	2.66
2	50X5.0	F37-632-50X5.0TFCF	37.5	10.0	IN32-50X5.0TFCF	OR41X1.78X	2.68
2	50X6.0	F37-632-50X6.0TFCF	35.0	10.0	IN32-50X6.0TFCF	OR41X1.78X	2.71
2	60X3.0	F37-632-60X3.0TFCF	46.0	12.0	IN32-60X3.0TFCF	OR53.7X1.78X	2.71
2	60X5.0	F37-632-60X5.0TFCF	46.0	11.0	IN32-60X5.0TFCF	OR50.52X1.78X	2.68
2	60X6.0	F37-632-60X6.0TFCF	45.5	11.0	IN32-60X6.0TFCF	OR47.37X1.78X	2.67

**Flanges for M12 bolts also available (F37-620H12-...TFCF).
Other sizes on request. *Incl. adapter sleeve or jump size flange if necessary.
Please change suffixes according to material/surface required

Order code suffixes		
Material	Suffix surface and material	Example
Steel, zinc plated, Cr(VI)-free	CF	F37-624-50X5.0TFCF
Stainless steel	SS	F37-624-50X5.0TFSS



SL – Sleeve

SAE 6000/ISO 6162-2

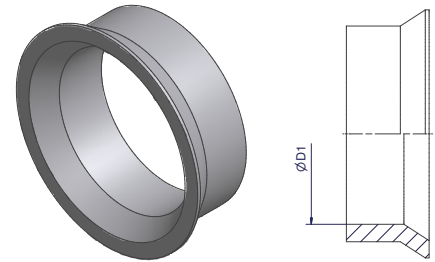

Size Inch	Tube OD	Order code	D1	Weight body (Steel) kg/1 piece
1/2	16	SL08-25-16-CFX	16.3	0.04
1/2	18	SL08-25-18-CFX	18.3	0.04
1/2	20	SL08-25-20-CFX	20.3	0.04
3/4	20	SL12-30-20-CFX	20.3	0.04
3/4	25	SL12-30-25-CFX*	25.2	0.04
1	25	SL16-38-25-CFX*	25.2	0.04
1	30	SL16-38-30-CFX*	30.2	0.04
1 1/4	30	SL20-42-30-CFX	30.2	0.04
1 1/4	38	SL20-42-38-CFX*	38.3	0.04
1 1/2	38	SL24-50-38-CFX*	38.3	0.14
1 1/2	42	SL24-50-42-CFX*	42.3	0.10
2	50	SL32-60-50-CFX*	50.3	0.16

*By use of jump size flanges, no adapter sleeves necessary. For jump size flanges see page 103.

Please change suffixes according to material/surface required

Order code suffixes		
Material	Suffix surface and material	Example
Steel, zinc plated, Cr(VI)-free	CF	SL24-50-42-CFX
Stainless steel	SS	SL24-50-42-SSX

R – Retaining ring

SAE 6000/ISO 6162-2

Size Inch	Tube	Order code	D	S
1/2	26X6.0	R08X	22.3	4.0
3/4	36X8.0	R12X	32.3	4.0
1	39X7.5	R16X	34.3	5.0
1 1/4	46X8.0	R20X	41.3	5.0
1 1/2	56X8.5	R24X	51.3	5.0
2	66X8.5	R32X	61.3	5.0
2 1/2	80X10.0	R40X	75.3	5.0
3	97X12.0	R48X	91.3	6.0

Material: Stainless steel

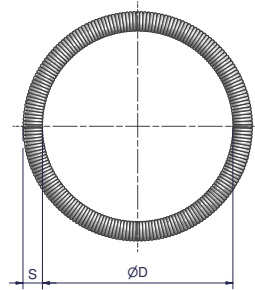

MTF-R – Male thread adapter, BSPP

SAE 6000/ISO 6162-2

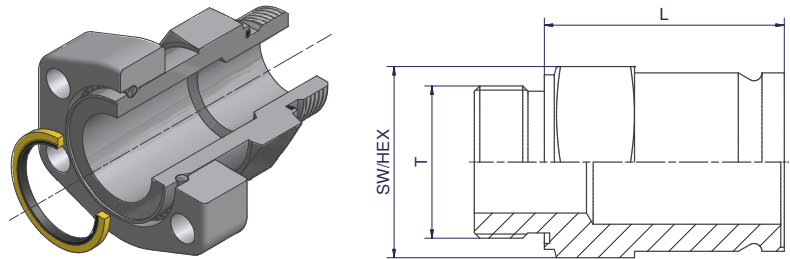

Size Inch	Tube	Complete part Order code	Body incl. ED Seal Order code	L	T (BSPP)	SW/HEX	Weight body (Steel) kg/1 piece
1/2	26X6.0	R-608MTFRCF	MTF08ROMDCF	61.0	G 1/2 A	27	0.21
3/4	36X8.0	R-612MTFRCF	MTF12ROMDCF	61.0	G 3/4 A	36	0.32
3/4	36X8.0	R-612MTFR1/2CF	MTF12R1/2OMDCF	61.0	G 1/2 A	36	0.32
1	39X7.5	R-616MTFRCF	MTF16ROMDCF	69.0	G 1 A	41	0.50
1	39X7.5	R-616MTFR3/4CF	MTF16R3/4OMDCF	69.0	G 3/4 A	41	0.50
1 1/4	46X8.0	R-620MTFRCF	MTF20ROMDCF	80.0	G 1 1/4 A	50	0.75
1 1/4	46X8.0	R-620MTFR1CF	MTF20R1OMDCF	80.0	G 1 A	50	0.73
1 1/2	56X8.5	R-624MTFRCF	MTF24ROMDCF	93.0	G 1 1/2 A	60	1.20
1 1/2	56X8.5	R-624MTFR11/4CF	MTF24R11/4OMDCF	93.0	G 1 1/4 A	60	1.17
2	66X8.5	R-632MTFRCF	MTF32ROMDCF	104.0	G 2 A	75	1.87
2	66X8.5	R-632MTFR11/2CF	MTF32R11/2OMDCF	103.5	G 1 1/2 A	75	1.80
2 1/2	80X10.0	R-640MTFRCF	MTF40ROMDCF	134.0	G 2 1/2 A	85	3.50
2 1/2	80X10.0	R-640MTFR2CF	MTF40R2OMDCF	136.0	G 2 A	85	3.50
3	97X12.0	R-648MTFRCF	MTF48ROMDCF	145.0	G 3 A	95	5.00

Other sizes on request.

Please change suffixes according to material/surface required

Order code suffixes		
Material	Suffix surface and material	Example
Steel, zinc plated, Cr(VI)-free	CF	R-620MTFROMDCF
Stainless steel	SS	R-620MTFROMDSS

MTF-N – Male thread adapter, NPT

SAE 6000/ISO 6162-2

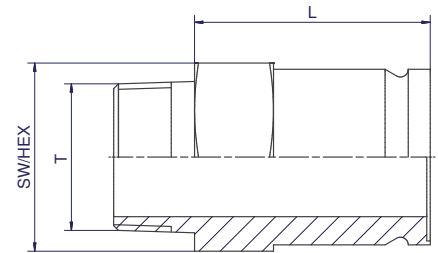
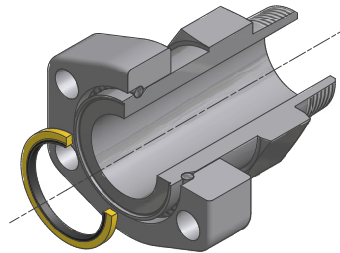

Size Inch	Tube	Complete part Order code	Body Order code	L	T (NPT)	SW/HEX	Weight body (Steel) kg/1 piece
1/2	26X6.0	R-608MTFNCF	MTF08NCFX	72.6	1/2-14	27	0.26
3/4	36X8.0	R-612MTFNCF	MTF12NCFX	72.6	3/4-14	36	0.48
1	39X7.5	R-616MTFNCF	MTF16NCFX	67.7	1-11.5	41	0.55
1 1/4	46X8.0	R-620MTFNCF	MTF20NCFX	75.0	1 1/4-11.5	50	0.70
1 1/2	56X8.5	R-624MTFNCF	MTF24NCFX	93.2	1 1/2-11.5	60	1.80
2	66X8.5	R-632MTFNCF	MTF32NCFX	100.4	2-11.5	75	2.40
2 1/2	80X10.0	R-640MTFNCF	MTF40NCFX	130.0	2 1/2-8	85	3.40
3	97X12.0	R-648MTFNCF	MTF48NCFX	141.2	3-8	95	4.90

Other sizes on request.

Please change suffixes according to material/surface required

Order code suffixes		
Material	Suffix surface and material	Example
Steel, zinc plated, Cr(VI)-free	CF	R-620MT0NCF
Stainless steel	SS	R-620MTFNSS



FTF-R – Female thread adapter, BSPP

SAE 6000/ISO 6162-2

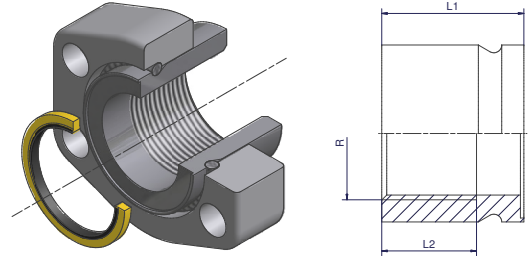

Size Inch	Tube	Complete part Order code	Body Order code	L1	L2	R (BSPP)	Weight body (Steel) kg/1 piece
1/2	26X6.0	R-608FTFRCF	FTF08RCFX	35	25	G 1/4	0.11
3/4	36X8.0	R-612FTFRCF	FTF12RCFX	40	25	G 1/2	0.22
1	39X7.5	R-616FTFRCF	FTF16RCFX	40	25	G 3/4	0.20
1 1/4	46X8.0	R-620FTFRCF	FTF20RCFX	42	30	G 1	0.30
1 1/2	56X8.5	R-624FTFRCF	FTF24RCFX	45	30	G 1 1/4	0.45
2	66X8.5	R-632FTFRCF	FTF32RCFX	55	40	G 1 1/2	0.75
2 1/2	80X10.0	R-640FTFRCF	FTF40RCFX	80	40	G 2	1.52
3	97X12.0	R-648FTFRCF	FTF48RCFX	85	50	G 2 1/2	2.11

Other sizes on request.

Please change suffixes according to material/surface required

Order code suffixes		
Material	Suffix surface and material	Example
Steel, zinc plated, Cr(VI)-free	CF	R-620FTFRCF
Stainless steel	SS	R-620FTFRSS

Retaining ring hose couplings

SAE 3000/ISO 6162-1 or ISO 6162-2

X5 and K5 Flange - Straight

Full flange system for ISO 6162-1 or ISO 6162-2

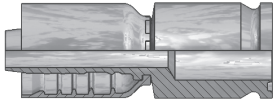

1X577-...



KX5V6-...

X7 and K7 Flange - 45° Elbow

Full flange system for ISO 6162-1 or ISO 6162-2

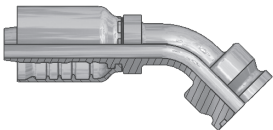

1X777-...



KX7V6-...

X9 and K9 Flange - 90° Elbow

Full flange system for ISO 6162-1 or ISO 6162-2

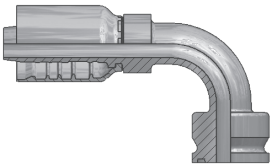

1X977-...

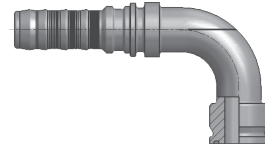

KX9V6-...

Details about hose fittings and the associated hose types can be found in the catalog of PHDE CAT/4400/UK.

WA – Weld adapter connection

SAE 6000/ISO 6162-2

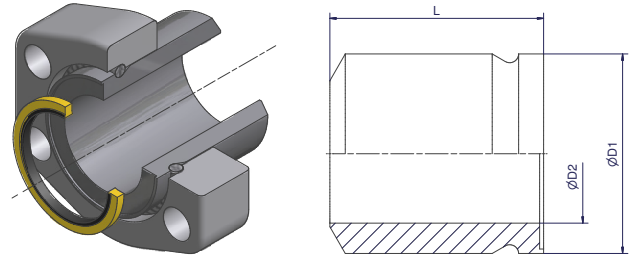

Size Inch	Tube	Complete Part Order code	Retaining Ring	Bonded Seal	Flange Order code	Weld Adapter Body Order code	D1	D2	L	Weight (Steel) kg/1 kit
1/2	12X1.5	R-608WA-12X1.5S	R08X	BS08SNX	R-608-CFX	WA08-12X1.5SX	26	14	40	0.29
1/2	16X2.0	R-608WA-16X2.0S	R08X	BS08SNX	R-608-CFX	WA08-16X2.0SX	26	14	40	0.30
1/2	18X2.0	R-608WA-18X2.0S	R08X	BS08SNX	R-608-CFX	WA08-18X2.0SX	26	14	40	0.30
1/2	20X2.0	R-608WA-20X2.5S	R08X	BS08SNX	R-608-CFX	WA08-20X2.5SX	26	14	40	0.30
1/2	21.3X2.1	R-608WA-21.3X2.1S	R08X	BS08SNX	R-608-CFX	WA08-21.3X2.1SX	26	14	40	0.30
1/2	21.3X2.8	R-608WA-21.3X2.8S	R08X	BS08SNX	R-608-CFX	WA08-21.3X2.8SX	26	14	40	0.30
1/2	21.3X3.7	R-608WA-21.3X3.7S	R08X	BS08SNX	R-608-CFX	WA08-21.3X3.7SX	26	14	45	0.31
1/2	21.3X4.8	R-608WA-21.3X4.8S	R08X	BS08SNX	R-608-CFX	WA08-21.3X4.8SX	26	14	45	0.32
1/2	21.3X7.5	R-608WA-21.3X7.5S	R08X	BS08SNX	R-608-CFX	WA08-21.3X7.5SX	26	14	45	0.32
1/2	25X2.5	R-608WA-25X2.5S	R08X	BS08SNX	R-608-CFX	WA08-25X2.5SX	26	14	40	0.29
1/2	26X6.0	R-608WA-26X6.0S	R08X	BS08SNX	R-608-CFX	WA08-26X6.0SX	26	14	40	0.31
3/4	20X2.5	R-612WA-20X2.5S	R12X	BS12SNX	R-612-CFX	WA12-20X2.5SX	36	20	45	0.41
3/4	25X3.0	R-612WA-25X3.0S	R12X	BS12SNX	R-612-CFX	WA12-25X3.0SX	36	20	45	0.41
3/4	26.7X2.1	R-612WA-26.7X2.1S	R12X	BS12SNX	R-612-CFX	WA12-26.7X2.1SX	36	20	45	0.40
3/4	26.7X2.8	R-612WA-26.7X2.8S	R12X	BS12SNX	R-612-CFX	WA12-26.7X2.8SX	36	20	45	0.41
3/4	26.7X3.9	R-612WA-26.7X3.9S	R12X	BS12SNX	R-612-CFX	WA12-26.7X3.9SX	36	20	45	0.41
3/4	26.7X5.6	R-612WA-26.7X5.6S	R12X	BS12SNX	R-612-CFX	WA12-26.7X5.6SX	36	20	50	0.44
3/4	26.7X7.8	R-612WA-26.7X7.8S	R12X	BS12SNX	R-612-CFX	WA12-26.7X7.8SX	36	20	50	0.45
3/4	30X3.0	R-612WA-30X3.0S	R12X	BS12SNX	R-612-CFX	WA12-30X3.0SX	36	20	50	0.41
3/4	30X4.0	R-612WA-30X4.0S	R12X	BS12SNX	R-612-CFX	WA12-30X4.0SX	36	20	50	0.42
3/4	30X6.0	R-612WA-30X6.0S	R12X	BS12SNX	R-612-CFX	WA12-30X6.0SX	36	20	50	0.44
3/4	36X8.0	R-612WA-36X8.0S	R12X	BS12SNX	R-612-CFX	WA12-36X8.0SX	36	20	50	0.46
1	25X3.0	R-616WA-25X3.0S	R16X	BS16SNX	R-616-CFX	WA16-25X3.0SX	39	19	60	0.66
1	30X4.0	R-616WA-30X4.0S	R16X	BS16SNX	R-616-CFX	WA16-30X4.0SX	39	20	60	0.65
1	33.4X2.8	R-616WA-33.4X2.8S	R16X	BS16SNX	R-616-CFX	WA16-33.4X2.8SX	39	24	60	0.61
1	33.4X3.4	R-616WA-33.4X3.4S	R16X	BS16SNX	R-616-CFX	WA16-33.4X3.4SX	39	24	60	0.62
1	33.4X4.6	R-616WA-33.4X4.6S	R16X	BS16SNX	R-616-CFX	WA16-33.4X4.6SX	39	24	60	0.64
1	33.4X6.5	R-616WA-33.4X6.5S	R16X	BS16SNX	R-616-CFX	WA16-33.4X6.5SX	39	20	60	0.70
1	33.4X9.1	R-616WA-33.4X9.1S	R16X	BS16SNX	R-616-CFX	WA16-33.4X9.1SX	39	24	60	0.69
1	38X4.0	R-616WA-38X4.0S	R16X	BS16SNX	R-616-CFX	WA16-38X4.0SX	39	24	55	0.59
1	38X5.0	R-616WA-38X5.0S	R16X	BS16SNX	R-616-CFX	WA16-38X5.0SX	39	24	55	0.61
1	38X7.0	R-616WA-38X7.0S	R16X	BS16SNX	R-616-CFX	WA16-38X7.0SX	39	24	60	0.67
1	39X7.5	R-616WA-39X7.5S	R16X	BS16SNX	R-616-CFX	WA16-39X7.5SX	39	24	50	0.62
1 1/4	30X4.0	R-620WA-30X4.0S	R20X	BS20SNX	R-620-CFX	WA20-30X4.0SX	46	22	70	1.06
1 1/4	38X4.0	R-620WA-38X4.0S	R20X	BS20SNX	R-620-CFX	WA20-38X4.0SX	46	30	65	0.91
1 1/4	38X5.0	R-620WA-38X5.0S	R20X	BS20SNX	R-620-CFX	WA20-38X5.0SX	46	28	65	0.96
1 1/4	42X3.0	R-620WA-42X3.0S	R20X	BS20SNX	R-620-CFX	WA20-42X3.0SX	46	30	65	0.86
1 1/4	42X4.0	R-620WA-42X4.0S	R20X	BS20SNX	R-620-CFX	WA20-42X4.0SX	46	30	65	0.89
1 1/4	42X6.0	R-620WA-42X6.0S	R20X	BS20SNX	R-620-CFX	WA20-42X6.0SX	46	30	65	0.95
1 1/4	42.2X2.7	R-620WA-42.2X2.7S	R20X	BS20SNX	R-620-CFX	WA20-42.2X2.7SX	46	30	65	0.85
1 1/4	42.2X3.6	R-620WA-42.2X3.6S	R20X	BS20SNX	R-620-CFX	WA20-42.2X3.6SX	46	30	65	0.88
1 1/4	42.2X4.9	R-620WA-42.2X4.9S	R20X	BS20SNX	R-620-CFX	WA20-42.2X4.9SX	46	30	65	0.92
1 1/4	42.2X6.4	R-620WA-42.2X6.4S	R20X	BS20SNX	R-620-CFX	WA20-42.2X6.4SX	46	29	65	0.96
1 1/4	42.2X9.7	R-620WA-42.2X9.7S	R20X	BS20SNX	R-620-CFX	WA20-42.2X9.7SX	46	23	65	1.08
1 1/4	46X7.0	R-620WA-46X7.0S	R20X	BS20SNX	R-620-CFX	WA20-46X7.0SX	46	30	65	0.97
1 1/4	46X8.0	R-620WA-46X8.0S	R20X	BS20SNX	R-620-CFX	WA20-46X8.0SX	46	30	55	0.90

See next page

WA – Weld adapter connection continued

SAE 6000/ISO 6162-2

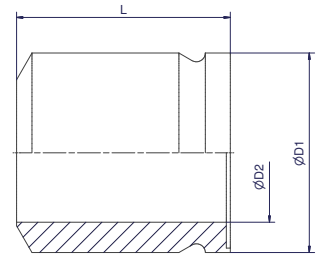
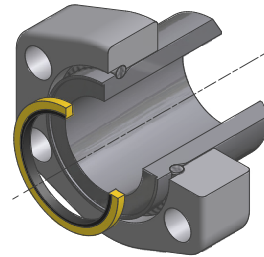

Size Inch	Tube	Complete Part Order code	Retaining Ring	Bonded Seal	Flange Order code	Weld Adapter Body Order code	D1	D2	L	Weight (Steel) kg/1 kit
1 1/2	38X5.0	R-624WA-38X5.0S	R24X	BS24SNX	R-624-CFX	WA24-38X5.0SX	56	28	75	1.48
1 1/2	48.3X2.8	R-624WA-48.3X2.8S	R24X	BS24SNX	R-624-CFX	WA24-48.3X2.8SX	56	39	70	1.14
1 1/2	48.3X3.7	R-624WA-48.3X3.7S	R24X	BS24SNX	R-624-CFX	WA24-48.3X3.7SX	56	39	70	1.18
1 1/2	48.3X5.1	R-624WA-48.3X5.1S	R24X	BS24SNX	R-624-CFX	WA24-48.3X5.1SX	56	38	70	1.24
1 1/2	48.3X7.1	R-624WA-48.3X7.1S	R24X	BS24SNX	R-624-CFX	WA24-48.3X7.1SX	56	34	70	1.36
1 1/2	48.3X10.2	R-624WA-48.3X10.2S	R24X	BS24SNX	R-624-CFX	WA24-48.3X10.2SX	56	30	70	1.32
1 1/2	50X3.0	R-624WA-50X3.0S	R24X	BS24SNX	R-624-CFX	WA24-50X3.0SX	56	39	70	1.13
1 1/2	50X5.0	R-624WA-50X5.0S	R24X	BS24SNX	R-624-CFX	WA24-50X5.0SX	56	40	70	1.20
1 1/2	50X6.0	R-624WA-50X6.0S	R24X	BS24SNX	R-624-CFX	WA24-50X6.0SX	56	38	70	1.26
1 1/2	50x9.0	R-624WA-50X9.0S	R24X	BS24SNX	R-624-CFX	WA24-50X9.0SX	56	32	70	1.42
1 1/2	56X8.5	R-624WA-56X8.5S	R24X	BS24SNX	R-624-CFX	WA24-56X8.5SX	56	39	60	1.18
2	48.3X5.6	R-632WA-48.3X5.6S	R32X	BS32SNX	R-632-CFX	WA32-48.3X5.6SX	66	37	90	2.40
2	50X9.0	R-632WA-50X9.0S	R32X	BS32SNX	R-632-CFX	WA32-50X9.0SX	66	32	90	2.61
2	60X3.0	R-632WA-60X3.0S	R32X	BS32SNX	R-632-CFX	WA32-60X3.0SX	66	49	90	1.89
2	60X5.0	R-632WA-60X5.0S	R32X	BS32SNX	R-632-CFX	WA32-60X5.0SX	66	50	90	1.99
2	60X6.0	R-632WA-60X6.0S	R32X	BS32SNX	R-632-CFX	WA32-60X6.0SX	66	48	90	2.10
2	60X8.0	R-632WA-60X8.0S	R32X	BS32SNX	R-632-CFX	WA32-60X8.0SX	66	44	90	2.28
2	60x10.0	R-632WA-60X10.0S	R32X	BS32SNX	R-632-CFX	WA32-60X10.0SX	66	40	90	2.46
2	60.3X2.8	R-632WA-60.3X2.8S	R32X	BS32SNX	R-632-CFX	WA32-60.3X2.8SX	66	49	90	1.87
2	60.3X3.9	R-632WA-60.3X3.9S	R32X	BS32SNX	R-632-CFX	WA32-60.3X3.9SX	66	49	90	1.95
2	60.3X5.5	R-632WA-60.3X5.5S	R32X	BS32SNX	R-632-CFX	WA32-60.3X5.5SX	66	49	90	2.04
2	60.3X8.7	R-632WA-60.3X8.7S	R32X	BS32SNX	R-632-CFX	WA32-60.3X8.7SX	66	43	90	2.34
2	60.3X11.1	R-632WA-60.3X11.1S	R32X	BS32SNX	R-632-CFX	WA32-60.3X11.1SX	66	38	90	2.54
2	66X8.5	R-632WA-66X8.5S	R32X	BS32SNX	R-632-CFX	WA32-66X8.5SX	66	49	75	1.95
2 1/2	65X8.5	R-640WA-65X8.5S	R40X	BS40SNX	R-640-CFX	WA40-65X8.5SX	80	49	105	8.20
2 1/2	73X7.0	R-640WA-73X7.0S	R40X	BS40SNX	R-640-CFX	WA40-73X7.0SX	80	59	105	7.69
2 1/2	75X3.0	R-640WA-75X3.0S	R40X	BS40SNX	R-640-CFX	WA40-75X3.0SX	80	60	105	7.30
2 1/2	75X5.0	R-640WA-75X5.0S	R40X	BS40SNX	R-640-CFX	WA40-75X5.0SX	80	60	105	7.47
2 1/2	76.1X6.3	R-640WA-76.1X6.3S	R40X	BS40SNX	R-640-CFX	WA40-76.1X6.3SX	80	60	105	7.55
2 1/2	76.1X12.5	R-640WA-76.1X12.5S	R40X	BS40SNX	R-640-CFX	WA40-76.1X12.5SX	80	51	105	8.27
2 1/2	80X10.0	R-640WA-80X10.0S	R40X	BS40SNX	R-640-CFX	WA40-80X10.0SX	80	60	90	7.50
3	76.1X12.5	R-648WA-76.1X12.5S	R48X	BS48SNX	R-648-CFX	WA48-76.1X12.5SX	97	51	120	11.58
3	80X10.0	R-648WA-80X10.0S	R48X	BS48SNX	R-648-CFX	WA48-80X10.0SX	97	60	120	11.47
3	88.9X3.1	R-648WA-88.9X3.1S	R48X	BS48SNX	R-648-CFX	WA48-88.9X3.1SX	97	73	120	10.58
3	88.9X5.5	R-648WA-88.9X5.5S	R48X	BS48SNX	R-648-CFX	WA48-88.9X5.5SX	97	73	120	10.87
3	88.9X7.7	R-648WA-88.9X7.7S	R48X	BS48SNX	R-648-CFX	WA48-88.9X7.7SX	97	74	120	11.07
3	88.9X8.8	R-648WA-88.9X8.8S	R48X	BS48SNX	R-648-CFX	WA48-88.9X8.8SX	97	71	120	11.30
3	88.9X11.1	R-648WA-88.9X11.1S	R48X	BS48SNX	R-648-CFX	WA48-88.9X11.1SX	97	67	120	11.74
3	88.9X12.5	R-648WA-88.9X12.5S	R48X	BS48SNX	R-648-CFX	WA48-88.9X12.5SX	97	64	120	12.00
3	88.9X15.2	R-648WA-88.9X15.2S	R48X	BS48SNX	R-648-CFX	WA48-88.9X15.2SX	97	59	120	12.40
3	90X3.5	R-648WA-90X3.5S	R48X	BS48SNX	R-648-CFX	WA48-90X3.5SX	97	73	120	10.59
3	90X5.0	R-648WA-90X5.0S	R48X	BS48SNX	R-648-CFX	WA48-90X5.0SX	97	80	120	10.90
3	90X9.0	R-648WA-90X9.0S	R48X	BS48SNX	R-648-CFX	WA48-90X9.0SX	97	72	120	11.25
3	97X12.0	R-648WA-97X12.0S	R48X	BS48SNX	R-648-CFX	WA48-97X12.0SX	97	73	110	11.05

Other sizes on request.

Please change suffixes according to material/surface required

Order code suffixes		
Material	Suffix surface and material	Example
Steel	S	R-620WA-46X8.0S
Stainless steel	SS	R-620WA-46X8.0SS



BF – Bulkhead flange

SAE 6000/ISO 6162-2

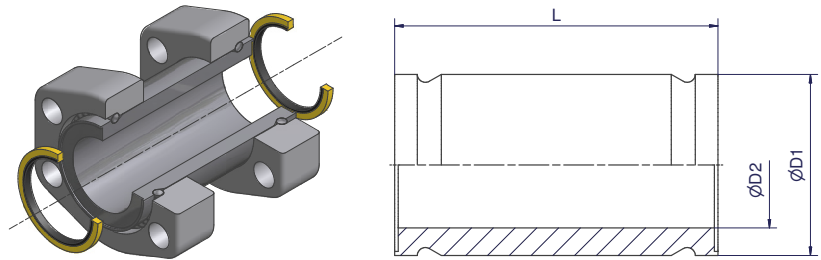

Size Inch	Complete Part Order code	Bulkhead Body Order code	D1	D2	L	Weight body (Steel) kg/1 piece
1/2	R-608BFS	BF08SX	26	14	170	0.49
3/4	R-612BFS	BF12SX	36	20	170	0.92
1	R-616BFS	BF16SX	39	24	170	0.96
1 1/4	R-620BFS	BF20SX	46	30	180	1.30
1 1/2	R-624BFS	BF24SX	56	39	180	1.75
2	R-632BFS	BF32SX	66	49	210	2.45
2 1/2	R-640BFS	BF40SX	80	60	220	3.70
3	R-648BFS	BF48SX	97	73	240	7.85

Other sizes on request.

Please change suffixes according to material/surface required

Order code suffixes		
Material	Suffix surface and material	Example
Steel	S	R-620BFS
Stainless steel	SS	R-620BFSS

RF – Reducer flange

SAE 6000/ISO 6162-2

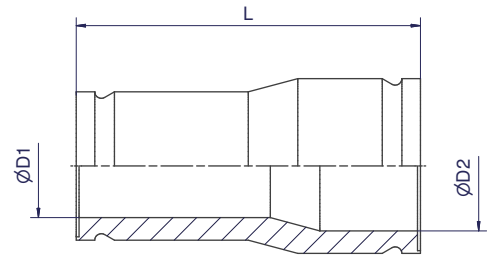
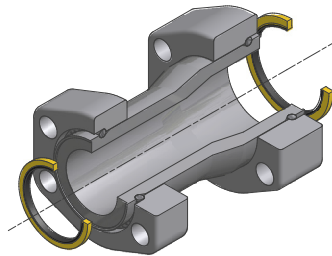

Size Inch	Complete Part Order code	Reducer Body Order code	D1	D2	L	Weight body (Steel) kg/1 piece
3/4 - 1/2	R-612-608RFCF	RF12-08CFX	14	20	65	0.3
1 - 1/2	R-616-608RFCF	RF16-08CFX	14	24	100	0.4
1 - 3/4	R-616-612RFCF	RF16-12CFX	20	24	100	0.6
1 1/4 - 1	R-620-616RFCF	RF20-16CFX	24	30	110	0.7
1 1/2 - 1	R-624-616RFCF	RF24-16CFX	24	39	115	0.9
1 1/2 - 1 1/4	R-624-620RFCF	RF24-20CFX	30	39	130	1.1
2 - 1 1/4	R-632-620RFCF	RF32-20CFX	30	49	130	1.3
2 - 1 1/2	R-632-624RFCF	RF32-24CFX	39	49	130	1.4
2 1/2 - 1 1/2	R-640-624RFCF	RF40-24CFX	39	60	150	2.1
2 1/2 - 2	R-640-632RFCF	RF40-32CFX	49	60	150	2.2
3 - 2	R-648-632RFCF	RF48-32CFX	49	73	180	3.4
3 - 2 1/2	R-648-640RFCF	RF48-40CFX	60	73	180	3.7

Other sizes on request.

Please change suffixes according to material/surface required

Order code suffixes		
Material	Suffix surface and material	Example
Steel, zinc plated, Cr(VI)-free	CF	R-620-616RFCF
Stainless steel	SS	R-620-616RFSS



FB90 – 90° Flange bend

SAE 6000/ISO 6162-2

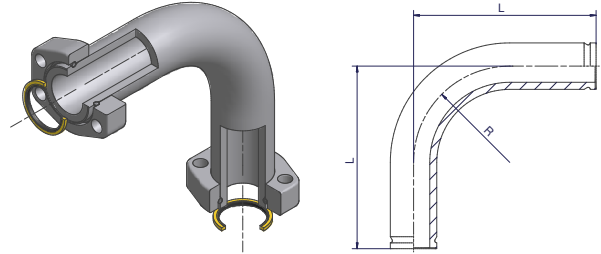

Size Inch	Tube	Complete Part Order code	90° Flange Bend Order code	L	R	Weight body (Steel) kg/1 piece
1 1/4	46X8.0	R-620FB90S	FB90-20SX*	180	96	2.35
1 1/2	56X8.5	R-624FB90CF	FB90-24CFX	220	116	3.84
2	66X8.5	R-632FB90CF	FB90-32CFX	275	165	5.72
2 1/2	80X10.0	R-640FB90S*	FB90-40SX*	370	200	11.20
3	97X12.0	R-648FB90S*	FB90-48SX*	450	243	19.90

*only available as Steel version.

Please change suffixes according to material/surface required

Order code suffixes			
Tube material	Suffix surface and material	Example	Comments
Steel, zinc plated, Cr(VI)-free	CF	R-624FB90CF	
Steel, black phosphated	SX	R-620FB90S	
Stainless steel	SS	R-620FB90SS	on request

FB45 – 45° Flange bend

SAE 6000/ISO 6162-2

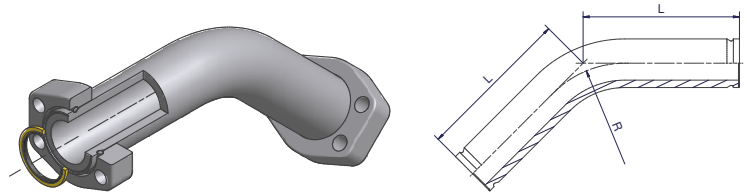

Size Inch	Tube	Complete Part Order code	45° Flange Bend Order code	L	R	Weight body (Steel) kg/1 piece
1 1/4	46X8.0	R-620FB45S	FB45-20SX*	150	96	2.18
1 1/2	56X8.5	R-624FB45CF	FB90-45CFX	180	116	3.49
2	66X8.5	R-632FB45CF	FB90-45CFX	220	165	5.16
2 1/2	80X10.0	R-640FB45S*	FB45-40SX*	240	200	8.07
3	97X12.0	R-648FB45S*	FB45-48SX*	260	243	12.70

Other sizes on request.
*only available as Steel version.

Please change suffixes according to material/surface required

Order code suffixes			
Tube material	Suffix surface and material	Example	Comments
Steel, zinc plated, Cr(VI)-free	CF	R-624FB45CF	
Steel, black phosphated	S	R-620FB45S	
Stainless steel	SS	R-620FB45SS	on request



FB90 – 90° Flange bend

SAE 6000/ISO 6162-2

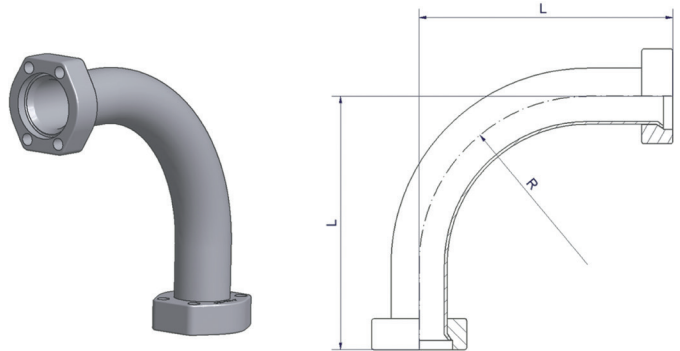

Size Inch	Tube	Complete Part Order code	L	R
1 1/2	50X5.0	F37-624FB90	220	150
2	60X5.0	F37-632FB90	275	180

Other sizes on request.

Please change suffixes according to material/surface required

Order code suffixes		
Material	Suffix surface and material	Example
Steel, zinc plated, Cr(VI)-free	CF	F37-624FB90CF
Stainless steel	SS	F37-624FB90SS

FB45 – 45° Flange bend

SAE 6000/ISO 6162-2

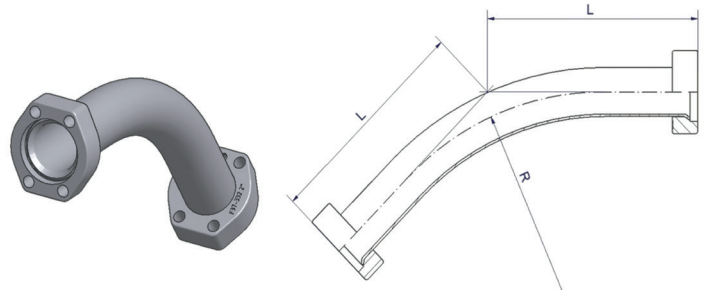

Size Inch	Tube	Complete Part Order code	L	R
1 1/2	50X5.0	F37-624FB45	180	150
2	60X5.0	F37-632FB45	220	180

Other sizes on request.

Please change suffixes according to material/surface required

Order code suffixes		
Material	Suffix surface and material	Example
Steel, zinc plated, Cr(VI)-free	CF	F37-624FB45CF
Stainless steel	SS	F37-624FB45SS



LF – Elbow flange

SAE 6000/ISO 6162-2

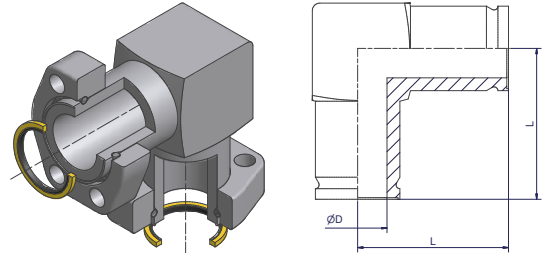

Size Inch	Complete Part Order code	Elbow Flange body Order code	D	L	Weight body (Steel) kg/1 piece
1/2	R-608LFCF	LF08CFX	14	70	0.50
3/4	R-612LFCF	LF12CFX	20	80	1.07
1	R-616LFCF	LF16CFX	24	85	1.32
1 1/4	R-620LFCF	LF20CFX	30	90	1.72
1 1/2	R-624LFCF	LF24CFX	39	100	2.60
2	R-632LFCF	LF32CFX	49	110	4.02
2 1/2	R-640LFCF	LF40CFX	60	130	6.40
3	R-648LFCF	LF48CFX	73	160	10.80

Other sizes on request.

Please change suffixes according to material/surface required

Order code suffixes		
Material	Suffix surface and material	Example
Steel, zinc plated, Cr(VI)-free	CF	R-620LFCF
Stainless steel	SS	R-620LFSS

TF – TEE flange

SAE 6000/ISO 6162-2

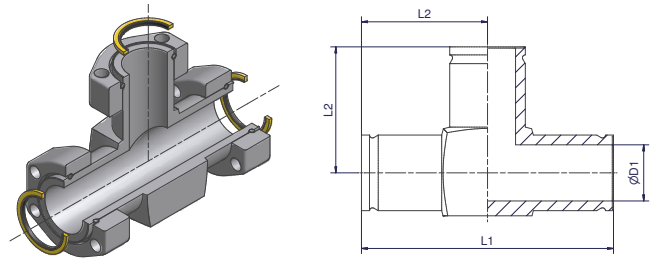

Size Inch	Complete Part Order code	Tee Flange body Order code	D1	L1	L2	Weight body (Steel) kg/1 piece
1/2	R-608TCF	TF08CFX	14	120	60	0.75
3/4	R-612TCF	TF12CFX	20	130	65	3.20
1	R-616TCF	TF16CFX	24	140	70	2.00
1 1/4	R-620TCF	TF20CFX	30	180	90	2.03
1 1/2	R-624TCF	TF24CFX	39	200	100	3.13
2	R-632TCF	TF32CFX	49	220	110	4.53
2 1/2	R-640TCF	TF40CFX	60	260	130	7.05
3	R-648TCF	TF48CFX	73	320	160	12.81

Other sizes on request.

Please change suffixes according to material/surface required

Order code suffixes		
Material	Suffix surface and material	Example
Steel, zinc plated, Cr(VI)-free	CF	R-620TCF
Stainless steel	SS	R-620TFSS



LB – Flange L-block

SAE 6000/ISO 6162-2

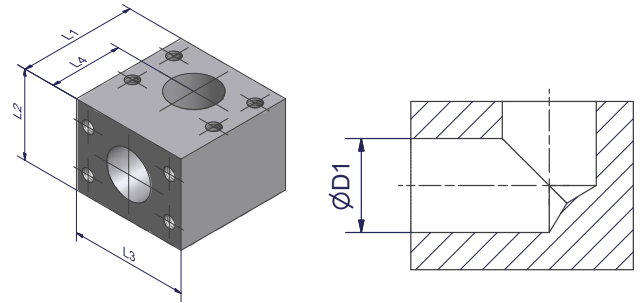

Size Inch	Order code	D1	L1	L2	L3	L4	Weight (Steel) kg/1 piece
1/2	LB608CFX	13	61	46	61	38	1.3
3/4	LB612CFX	19	75	60	75	49	2.4
1	LB616CFX	25	80	65	80	54	2.8
1 1/4	LB620CFX	30	86	64	90	57	3.2
1 1/2	LB624CFX	38	100	74	100	66	4.6
2	LB632CFX	48	122	88	132	78	8.8

Other sizes and custom versions on request.

Please change suffixes according to material/surface required

Order code suffixes		
Material	Suffix surface and material	Example
Steel, zinc plated, Cr(VI)-free	CF	LB620CFX
Stainless steel	SS	LB620SSX

LBR – Flange L-block reducer

SAE 6000/ISO 6162-2

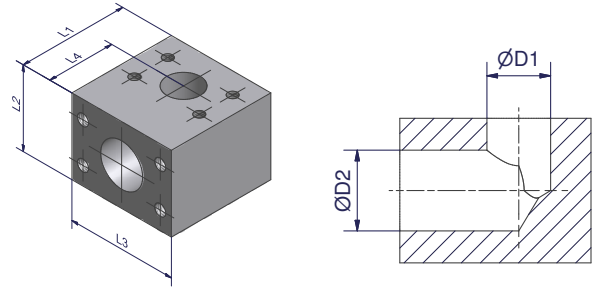

Size Inch	Order code	D1	D2	L1	L2	L3	L4	Weight (Steel) kg/1 piece
1 - 3/4	LBR616-612CFX	19	25	80	65	80	54	2.6
1 1/4 - 3/4	LBR620-612CFX	19	30	86	64	90	57	3.0
1 1/4 - 1	LBR620-616CFX	25	30	86	64	90	57	3.3
1 1/2 - 1	LBR624-616CFX	25	38	100	74	100	66	4.9
1 1/2 - 1 1/4	LBR624-620CFX	30	38	100	74	100	66	4.8
2 - 1	LBR632-616CFX	25	48	122	88	132	78	9.4
2 - 1 1/4	LBR632-620CFX	30	48	122	88	132	78	9.3
2 - 1 1/2	LBR632-624CFX	38	48	122	88	132	78	9.1

Other sizes and custom versions on request.

Please change suffixes according to material/surface required

Order code suffixes		
Material	Suffix surface and material	Example
Steel, zinc plated, Cr(VI)-free	CF	LBR620-616CFX
Stainless steel	SS	LBR620-616SSX



TB – Flange T-block

SAE 6000/ISO 6162-2

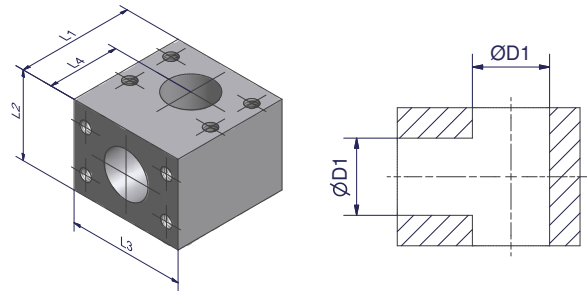

Size Inch	Order code	D1	L1	L2	L3	L4	Weight (Steel) kg/1 piece
1/2	TB608CFX	13	61	46	61	38	1.10
3/4	TB612CFX	19	75	60	75	49	2.27
1	TB616CFX	25	80	65	80	54	2.46
1 1/4	TB620CFX	30	86	64	90	57	3.04
1 1/2	TB624CFX	38	100	74	100	66	4.40
2	TB632CFX	50	122	88	132	78	8.07

Other sizes and custom versions on request.

Please change suffixes according to material/surface required

Order code suffixes		
Material	Suffix surface and material	Example
Steel, zinc plated, Cr(VI)-free	CF	TB620CFX
Stainless steel	SS	TB620SSX

TBR – Flange T-block reducer

SAE 6000/ISO 6162-2

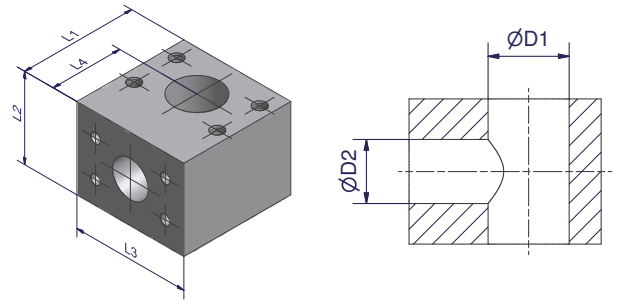

Size Inch	Order code	D1	D2	L1	L2	L3	L4	Weight (Steel) kg/1 piece
1 - 3/4 - 1	TBR616-612-616CFX	25	19	80	65	80	54	2.7
1 1/4 - 1 - 1 1/4	TBR620-616-620CFX	30	25	86	64	90	57	3.1
1 1/2 - 1 - 1 1/2	TBR624-616-624CFX	38	25	100	74	100	66	4.6
1 1/2 - 1 1/4 - 1 1/2	TBR624-620-624CFX	38	30	100	74	100	66	4.4
2 - 1 1/4 - 2	TBR632-620-632CFX	48	30	122	88	132	78	8.7
2 - 1 1/2 - 2	TBR632-624-632CFX	48	38	122	88	132	78	8.5

Other sizes and custom versions on request.

Please change suffixes according to material/surface required

Order code suffixes		
Material	Suffix surface and material	Example
Steel, zinc plated, Cr(VI)-free	CF	TBR620-616-620CFX
Stainless steel	SS	TBR620-616-620SSX



BFV – Blind flange

SAE 6000/ISO 6162-2

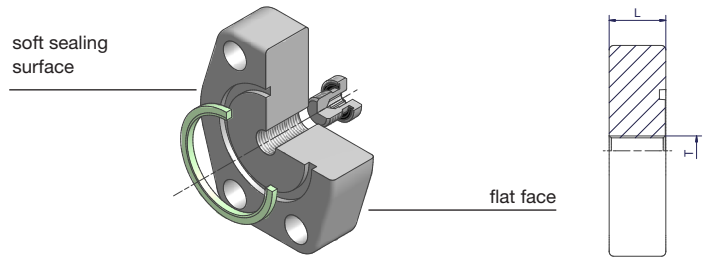

Size Inch	Flange incl. VSTI-ED and Seal Order code	L	T1	Weight body (Steel) kg/1 piece
1/2	F37-608BFVCF	20	G 1/4	0.29
3/4	F37-612BFVCF	24	G 1/4	0.57
1	F37-616BFVCF	24	G 1/4	0.76
1 1/4	F37-620BFVCF	30	G 1/4	1.27
1 1/4	F37-620H12BFVCF	30	G 1/4	1.31
1 1/2	F37-624BFVCF	35	G 1/4	2.16
2	F37-632BFVCF	40	G 1/4	3.40
2 1/2	F37-640BFVCF	50	G 1/4	7.74
3	F37-648BFVCF	52	G 1/4	11.65

Please change suffixes according to material/surface required

Order code suffixes		
Material	Suffix surface and material	Example
Steel, zinc plated, Cr(VI)-free	CF	F37-620BFVCF
Stainless steel	SS	F37-620BFVSS

BS – Bonded seal

SAE 6000/ISO 6162-2

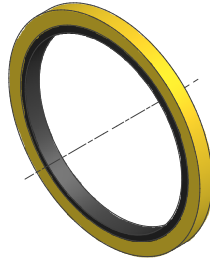

Size Inch	Steel	Stainless Steel
1/2	BS08SNX	BS08SSNX
3/4	BS12SNX	BS12SSNX
1	BS16SNX	BS16SSNX
1 1/4	BS20SNX	BS20SSNX
1 1/2	BS24SNX	BS24SSNX
2	BS32SNX	BS32SSNX
2 1/2	BS40SNX	BS40SSNX
3	BS48SNX	BS48SSNX

Sealing: NBR
Other sealing materials like FKM on request.

F37S/F37RS – F37 Seal

SAE 6000/ISO 6162-2

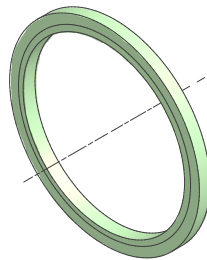

Size Inch	F37 Seal (F37 seal for flaring system)	F37RS (F37 seal for retaining ring system)
1/2	F37S08X	-
3/4	F37S12X	-
1	F37S16X	-
1 1/4	F37S20X	F37RS20X
1 1/2	F37S24X	F37RS24X
2	F37S32X	F37RS32X
2 1/2	F37S40X	F37RS40X
3	F37S48X	F37RS48X

Other sizes on request
Sealing: Polyurethane
Material properties and applications see page 20.



AO – Adapter bonded seal to F37 seal/O-Ring

SAE 6000/ISO 6162-2

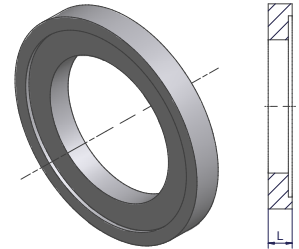

Size Inch	Adapter* Order code	L	Weight (Steel) kg/1 piece
1/2	AO08CFX	5	0.02
3/4	AO12CFX	5	0.02
1	AO16CFX	7	0.06
1 1/4	AO20CFX	7	0.06
1 1/2	AO24CFX	7	0.08
2	AO32CFX	7	0.10

*Part excluding seals.
Other sizes on request.
For assembling add L to the corresponding bolt length.

Please change suffixes according to material/surface required

Order code suffixes		
Material	Suffix surface and material	Example
Steel, zinc plated, Cr(VI)-free	CF	AO32CFX
Stainless steel	SS	AO32SSX

TBT – Tee between bonded seal

SAE 6000/ISO 6162-2

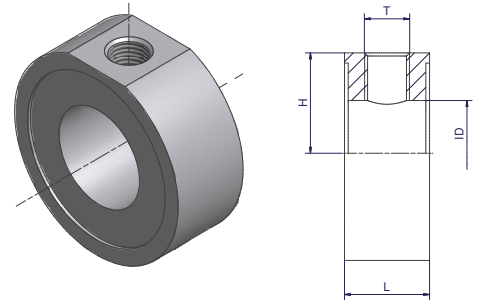

Size Inch	Order code*	L	H	T	ID	Weight (Steel) kg/1 piece
1	TBT16-1/4CFX	25	20.5	G 1/4	25	0.21
1 1/4	TBT20-1/4CFX	25	24.5	G 1/4	27	0.30
1 1/4	TBT20-1/2CFX	40	22.5	G 1/2	24	0.49
1 1/2	TBT24-1/4CFX	25	29.5	G 1/4	31	0.42
1 1/2	TBT24-1/2CFX	40	28.0	G 1/2	30	0.68
2	TBT32-1/4CFX	25	35.0	G 1/4	41	0.51
2	TBT32-1/2CFX	40	34.0	G 1/2	38	0.87
2 1/2	TBT40-1/4CFX	30	41.5	G 1/4	60	0.63
3	TBT48-1/4CFX	30	50.0	G 1/4	72	0.90

*Part excluding seals.
 For assembling add L to the corresponding bolt length.
 For testpoints and diagnostic test equipment see catalogue 4100, Industrial Tube Fittings Europe.

Alternative versions on request.

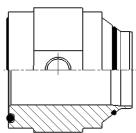

TFVB

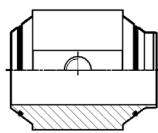

TTB

Please change suffixes according to material/surface required

Order code suffixes		
Material	Suffix surface and material	Example
Steel, zinc plated, Cr(VI)-free	CF	TBT24-1/4CFX
Stainless steel	SS	TBT24-1/4SSX



AP – SAE flange locking plate

SAE 6000/ISO 6162-2

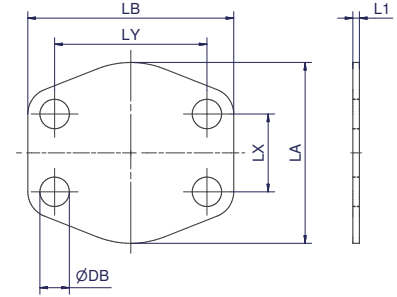

Nom. flange size		Order code	L1	LA	LB	LX	LY	DB	Weight body (Steel) kg/1 piece
SAE (In)	ISO (DN)								
1/2	13	8AP2	4	47	57	18.2	40.5	9.0	0.02
3/4	19	12AP2	4	53	71	23.8	50.8	11.0	0.02
1	25	16AP2	4	66	80	27.8	57.1	13.0	0.03
1 1/4	32	20AP2	4	77	94	31.8	66.7	15.0	0.04
1 1/2	38	24AP2	4	89	103	36.5	79.4	17.0	0.05
2	51	32AP2	4	123	135	44.5	96.8	21.0	0.06
2 1/2	64	40AP2	4	150	166	58.7	123.8	25.0	0.08
3	76	48AP2	4	178	210	71.4	152.4	32.0	0.10

This flange locking plate is not to be used under pressure!

Please change suffixes according to material/surface required

Order code suffixes			
Material	Suffix surface and material	Example	Description
Steel, zinc plated, Cr(VI)-free	CF	8AP2CF	only locking plate
Stainless steel	SS	8AP2SS	only locking plate
Steel (zinc plated, Cr(VI)-free), SBR 70 Shore A	CFSBR70	8AP2CFSBR70	locking incl. rubber plate L1 increase due to rubber plate

Bolts and nuts for flange

SAE 6000/ISO 6162-2



F37 Flare Flange

Size Inch	Flange	F37 Seal/Flat Face/Bonded Seal		Nut
		Recommended bolts Tube to Port	Recommended bolts Tube to Tube	
1/2	F37-608-CFX	4 x ZYLS8X35	4 x ZYLS8X65	4 x ISO4032-M8
3/4	F37-612-CFX	4 x ZYLS10X45	4 x ZYLS10X75	4 x ISO4032-M10
1	F37-616-CFX	4 x ZYLS12X45	4 x ZYLS12X75	4 x ISO4032-M12
1 1/4	F37-620-CFX	4 x ZYLS14X55	4 x ZYLS14X90	4 x ISO4032-M14
1 1/4	F37-620H12-CFX	4 x ZYLS12X55	4 x ZYLS12X90	4 x ISO4032-M12
1 1/2	F37-624-CFX	4 x ZYLS16X60	4 x ZYLS16X100	4 x ISO4032-M16
2	F37-632-CFX	4 x ZYLS20X70	4 x ZYLS20X120	4 x ISO4032-M20

Retaining Ring Flange

Size Inch	Flange	Flat Face/Bonded Seal		Pipe Seal Carrier (PSC)		Nut
		Recommended bolts Tube to Port	Recommended bolts Tube to Tube	Recommended bolts Tube to Port	Recommended bolts Tube to Tube	
1/2	R-608-CFX	4 x ZYLS8X35	4 x ZYLS8X60	-	-	4 x ISO4032-M8
3/4	R-612-CFX	4 x ZYLS10X45	4 x ZYLS10X70	-	-	4 x ISO4032-M10
1	R-616-CFX	4 x ZYLS12X45	4 x ZYLS12X80	-	-	4 x ISO4032-M12
1 1/4	R-620-CFX	4 x ZYLS14X55	4 x ZYLS14X90	4 x ZYLS14X60	4 x ZYLS14X100	4 x ISO4032-M14
1 1/4	R-620H12-CFX	4 x ZYLS12X55	4 x ZYLS12X90	4 x ZYLS12X60	4 x ZYLS12X100	4 x ISO4032-M12
1 1/2	R-624-CFX	4 x ZYLS16X60	4 x ZYLS16X100	4 x ZYLS16X70	4 x ZYLS16X110	4 x ISO4032-M16
2	R-632-CFX	4 x ZYLS20X70	4 x ZYLS20X120	4 x ZYLS20X80	4 x ZYLS20X130	4 x ISO4032-M20
2 1/2	R-640-CFX	4 x ZYLS24X90	4 x ZYLS24X150	4 x ZYLS24X110	4 x ZYLS24X160	4 x ISO4032-M24
3	R-648-CFX	4 x ZYLS30X100	4 x ZYLS30X160	4 x ZYLS30X120	4 x ZYLS30X170	4 x ISO4032-M30

Bolts and nuts are not included in complete part numbers.

Latest information about nuts and bolts see www.parker.com/hpce -> Resources -> Installation Guides & Manuals

Please add the suffixes according to the bolt quality

	Steel		0Stainless Steel
	8.8 zinc plated (VZX)	10.9 zinc flaked (ZNFLX)	A4-80X
Bolt	ZYLS16X60VZX	ZYLS16X60109ZNFLX	ZYLS16X60A4-80X
Nut	ISO4032-M12-8VZX	ISO4032-M12-10ZNFLX	ISO4032-M12-80X

* Bolt grade 10.9 recommended.
Bolt grade 8.8 can affect the pressure capability.



KH – Ball valve drilled and tapped for SAE 6000 and SAE 3000 flanges

SAE 6000/ISO 6162-2

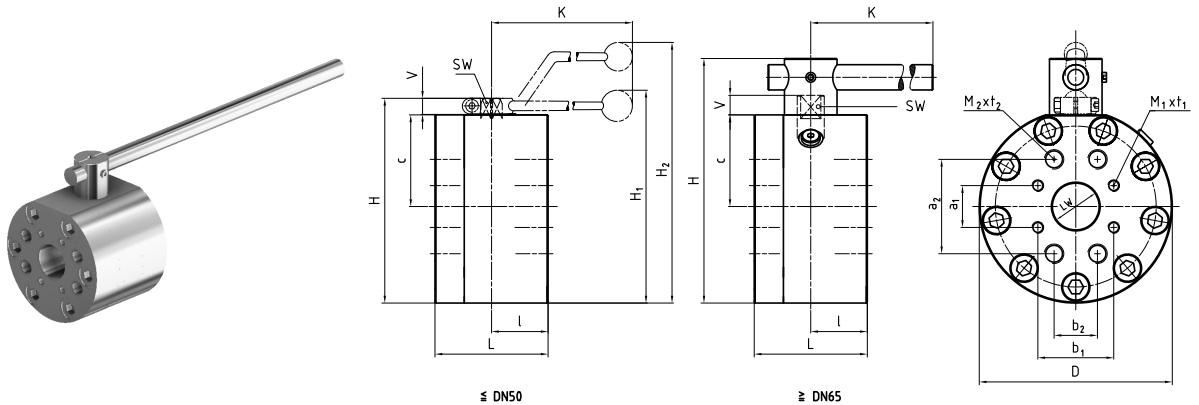

Material Steel

Size Inch	Order Code	DN	LW	L	I	D	H	c	V	K	SW	SAE 3000 boring pattern				SAE 6000 boring pattern				H1	H2	Material Code	Lever	Weight kg	W.P. bar
												a1	b1	M1	t1	a2	b2	M2	t2						
1/2	KH08-15CF	15	15	75	35	88	88	31.0	13	170	12	17.5	38.1	M08	18	40.5	18.2	M08	18	-	132	212A	St	2.96	350 / 420
3/4	KH12-20CF	20	20	80	35	98	100	36.5	14	170	14	22.2	47.6	M10	18	50.8	23.8	M10	18	-	150	212A	St	4.20	350 / 420
1	KH16-25CF	25	25	88	38	118	113	39.5	14	170	14	26.2	52.4	M10	20	57.2	27.8	M10	20	-	163	212A	St	6.00	320 / 420
1 1/4	KH20-32CF*	32	32	100	50	145	158	68.0	17	306	17	30.2	58.7	M10	20	66.7	31.8	M12	22	-	232	212A	St	11.70	280 / 420
1 1/4	KH20-32TM1214CF*	32	32	100	50	145	158	68.0	17	306	17	30.2	58.7	M12	20	66.7	31.8	M14	22	-	232	212A	St	11.65	210 / 400
1 1/2	KH24-38CF	40	38	110	55	165	178	78.0	17	306	17	35.7	69.9	M12	20	79.4	36.5	M16	27	-	252	212A	St	17.10	210 / 420
2	KH32-48CF	50	48	116	58	198	210	94.0	17	306	17	42.9	77.8	M12	20	96.8	44.5	M20	28	-	284-	212A	St	24.60	210 / 420
2 1/2	KH40-63CF	65	63	170	75	218	275	100.0	20	600	16	88.9	50.8	M12	19	58.7	123.8	M24	41	-	-	282A	St	44.40	175 / 420
3	KH48-76CF	80	76	170	79	258	315	115.0	26	600	19	106.4	61.9	M16	24	71.4	152.4	M30	47	-	-	282A	St	54.90	160 / 420

*Please choose between KH20-32CF and KH20-32TM1214CF according to needed connection threads M1 and M2.
Steel ball valves 1/2" up to 2" with SAE 3000 and SAE 6000 boring pattern.
The bore pattern for 2 1/2" and 3" is turned to 90°.

Please change suffixes according to material/surface required

Order code suffixes			
Material	Suffix surface and material	Example	Comments
Steel, zinc plated, Cr(VI)-free	CF	KH20-32CF	

	Material 221A	Material 282A
Body	Stahl	Steel
Ball	Stahl	Steel
Stem	Stahl	Stainless Steel
Ball seats	POM	POM
O-Ring	NBR	NBR
Tmin / Tmax	-10°C / 100°C	-10°C / 100°C

KH – Ball valve drilled and tapped for SAE 6000 flanges

SAE 6000/ISO 6162-2

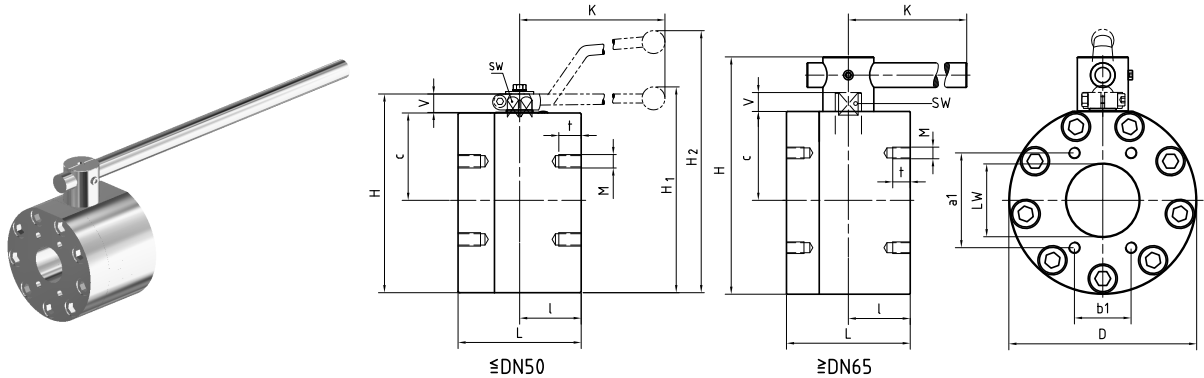

Material Stainless Steel

Size Inch	Order Code	DN	LW	L	I	D	H	c	V	K	SW	a1	b1	M	t	H1	H2	Material Code	Lever	Weight kg	W.P. (bar)
1/2	KH608-15SS	15	15	75	35	78	88	31.0	13	160	12	40.5	18.2	M08	18	-	127	442A	Al	2.50	420
3/4	KH612-20SS	20	20	80	35	98	100	36.5	14	200	14	50.8	23.8	M10	18	103	-	442A	Zn	4.25	420
1	KH616-25SS	25	25	88	38	118	113	39.5	14	200	14	57.2	27.8	M12	20	116	-	442A	Zn	6.30	420
1 1/4	KH620-32SS*	32	32	100	50	145	158	68.0	17	320	17	66.7	31.8	M12	22	167	-	442A	Al	11.80	420
1 1/4	KH620-32TM14SS*	32	32	100	50	145	158	68.0	17	320	17	66.7	31.8	M14	22	167	-	442A	Al	11.80	400
1 1/2	KH624-38SS	40	38	110	55	165	178	78.0	17	320	17	79.4	36.5	M16	27	187	-	442A	Al	16.90	420
2	KH632-48SS	50	48	116	58	198	210	94.0	17	320	17	96.8	44.5	M20	28	219	-	442A	Al	24.60	420
2 1/2	KH640-63SS	65	63	170	75	218	275	100.0	20	600	16	58.7	123.8	M24	41	-	-	442A	St	44.50	420
3	KH648-76SS	80	76	170	79	258	315	114.5	26	600	19	71.4	152.4	M30	47	-	-	442A	St	63.50	420

*Please choose between KH620-32SS and KH620-32TM14SS according to needed connection threads M.

Please change suffixes according to material/surface required

Order code suffixes			
Material	Suffix surface and material	Example	Comments
Stainless steel	SS	KH620-32SS	

	Material 442A
Body	Stainless Steel
Ball	Stainless Steel
Stem	Stainless Steel
Ball seats	POM
O-Ring	NBR
Tmin / Tmax	-30°C / 100°C



KH-R – Ball valve with SAE 6000 Flanges

SAE 6000/ISO 6162-2

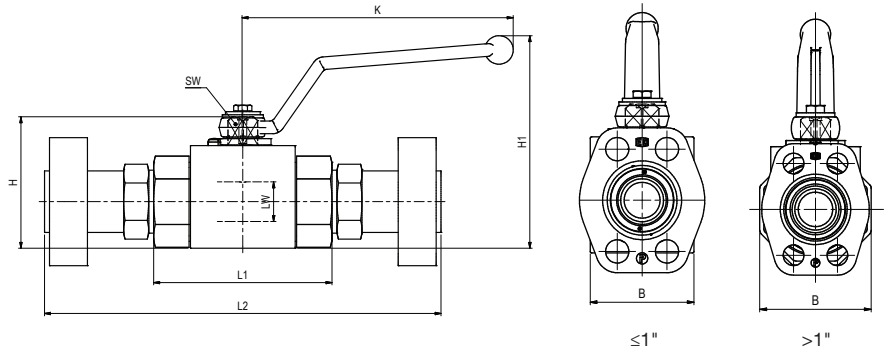
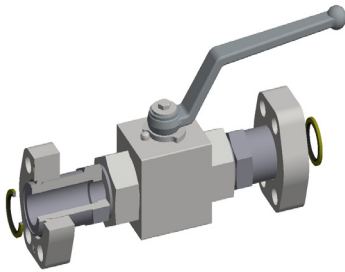

Material Steel

Size Inch	Complete part Order code	Valve body Order code	LW	L1	L2	B	H	SW	K	H1	Weight (Steel) kg/1 kit	W.P. bar
3/4	KH-R-612-20CF	KH-R-12-20CF	20	95	217	49	75	14	171	126	2.8	420
1	KH-R-616-25CF	KH-R-16-25CF	25	113	251	58	83	14	171	134	4.2	350
1	KH-R-616-420BDN25CF	KH-R-16-420BDN25CF	25	113	251	70	88	14	170	140	5.1	420
1 1/4	KH-R-620-32CF	KH-R-20-32CF	32	111	271	81	107	17	306	178	6.8	420
1 1/2	KH-R-624-38CF	KH-R-24-38CF	38	130	316	100	124	17	306	196	10.8	420
2	KH-R-632-48CF	KH-R-32-48CF	48	140	348	118	138	17	306	210	16.5	420

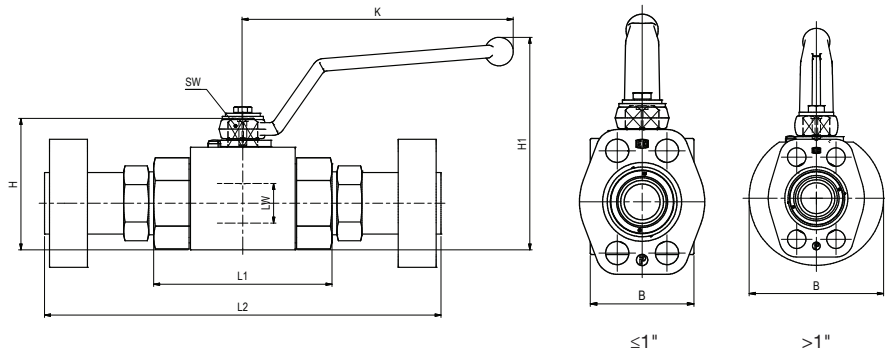
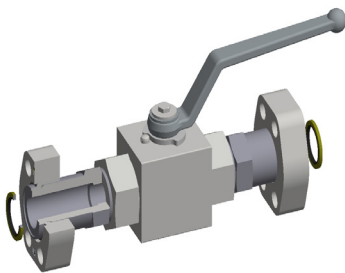

Material Stainless Steel

Size Inch	Complete part Order code	Valve body Order code	LW	L1	L2	B	H	SW	K	H1	Weight (Steel) kg/1 kit	W.P. bar
3/4	KH-R-612-20SS	KH-R-12-20SS	20	95	217	49	75	14	171	126	2.8	350
1	KH-R-616-25SS	KH-R-16-25SS	25	113	251	58	83	14	171	134	4.2	350
1	KH-R-616-420BDN25SS	KH-R-16-420BDN25SS	25	131	268	70	88	14	160	124	6.8	350
1 1/4	KH-R-620-32SS	KH-R-20-32SS	32	111	271	109	121	17	228	195	9.4	420
1 1/2	KH-R-624-38SS	KH-R-24-38SS	38	130	316	124	136	17	228	210	13.8	420
2	KH-R-632-48SS	KH-R-32-48SS	48	140	348	132	145	17	228	219	18.7	420

Other sizes on request.

Please change suffixes according to material/surface required

Order code suffixes		
Material	Suffix surface and material	Example
Steel, zinc plated, Cr(VI)-free	CF	KH-R-620-32CF
Stainless steel	SS	KH-R-620-32SS

	Material 112A	Material 442A
Body	Steel	Stainless Steel
Ball	Steel	Stainless Steel
Stem	Steel	Stainless Steel
Ball seats	POM	POM
O-Ring	NBR	NBR
Tmin / T max	-20°C / 100 °C	-30°C / 100°C

RHD-R – Non return valves

SAE 6000/ISO 6162-2

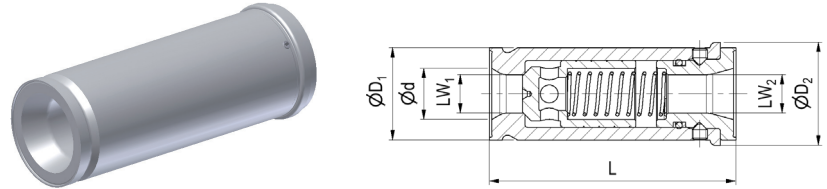

Material Steel

Size Inch	Complete part Order code	Valve body Order code	L	D1	D2	d	LW1	LW2	Weight body (Steel) kg/1 piece	W.P. bar
3/4	RHD-R-612-0.5BCF	RHD-R-12-0.5BCF	96.4	36	40.2	20.0	15	15.0	0.53	420
1	RHD-R-616-0.5BCF	RHD-R-16-0.5BCF	116.6	39	44.2	23.0	18	13.0	0.78	
1 1/4	RHD-R-620-0.5BCF	RHD-R-20-0.5BCF	135.6	46	51.1	30.0	20	17.0	1.26	
1 1/2	RHD-R-624-0.5BCF	RHD-R-24-0.5BCF	135.6	56	60.5	38.8	30	27.0	1.61	
2	RHD-R-632-0.5BCF	RHD-R-32-0.5BCF	180.1	66	70.5	49.0	40	36.4	2.54	

Opening pressure 0.5 bar.

Other pressure rates on request.

Complete Part = body + flanges + retaining rings + bonded seals.

Please change suffixes according to material/surface required

Order code suffixes		
Material	Suffix surface and material	Example
Steel, zinc plated, Cr(VI)-free	CF	RHD-R-620-0.5BCF
Stainless steel (inner parts steel)	SS	RHD-R-620-0.5BSS

	Materials
Body	Steel / Stainless Steel
Piston	Steel
O-Ring	NBR
Tmin / T max	-10°C / 100 °C









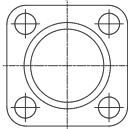
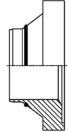
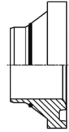
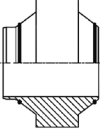
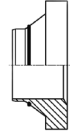

ISO 6164 System

250 – 400 bar

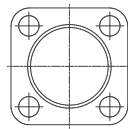
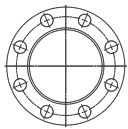
ENGINEERING YOUR SUCCESS.

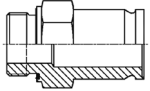
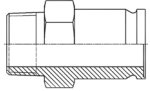
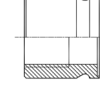
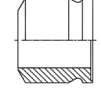
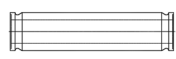
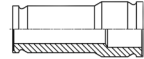
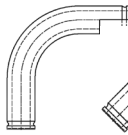
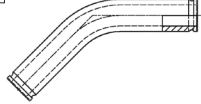
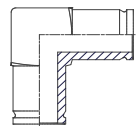
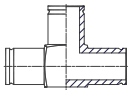
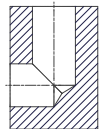
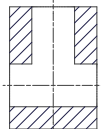
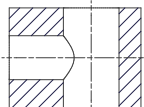
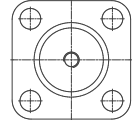
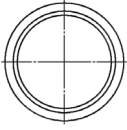
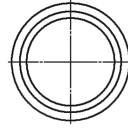
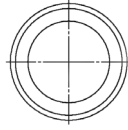
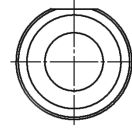
Programme overview ISO 6164 footprint

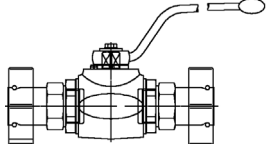
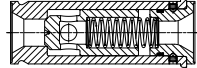
Parflange® F37 connection parts	Flanges  F37 – p.141/142							
	Inserts     TFB – p.145 TFV – p.146 TT – p.147 TF – p.148				Sleeve  SL – p.149			
Retaining ring connection parts	Flanges     R – p.143 R – p.143 R-Ring – p.150 PSC – p.144							
	Male / Female    MTF-R – p.151 MTF-N – p.152 FTF-R – p.153			Weld  WA – p.154				
	Tube to Tube       BF – p.155 RF – p.156 FB90 – p.157 FB45 – p.158 LF – p.159 TF – p.160							
SAE connection parts	Blocks     LB – p.161 TB – p.162 TBR – p.163 BFV – p.164							
Seals Adapter Bolts	Components     BS – p.165 F37S – p.165 AO – p.166 TBT – p.167				Bolts and Nuts  p.168			
Ball valves	   KH – p.169/170 KH-R – p.171 RHD-R – p.172							

F37 - Flare flange | ISO 6164 footprint

ISO 6164

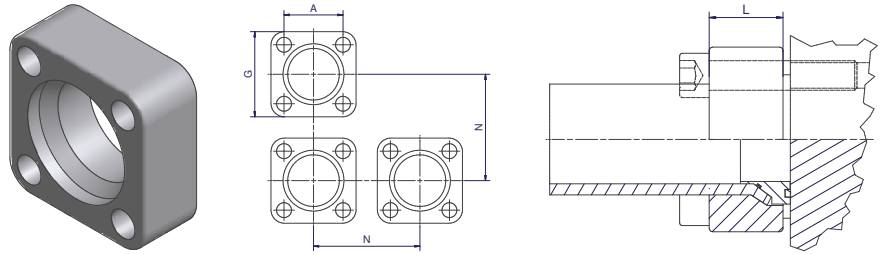

Parflange F37 flange dimensions

Size Inch	Flange Order code	A	G	N	L	Weight (Steel) kg/1 piece	W.P. bar
2	F37-432-CFX	69.3	100	105	40	1.80	400
2 1/2	F37-440-CFX	83.4	120	125	50	3.00	
2 1/2	F37-44073-CF*	83.4	120	125	50	3.10	
3	F37-448-CFX	102.5	150	155	52	5.40	
3	F37-448909-CF*	102.5	150	155	52	5.29	

* Heavy series (with lockring).

Please change suffixes according to material/surface required

Order code suffixes			
Material	Suffix surface and material	Example	Comments
Steel, zinc plated, Cr(VI)-free	CF	F37-432-CFX	
Stainless steel	SS	F37-432-SSX	
Galvanized hot dip zinc	TZN	F37-432-TZNX	on request

Parflange® F37 – ISO 6164

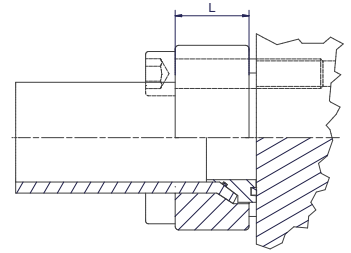
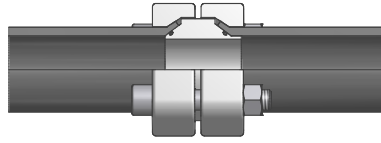

Part combination flaring ISO 6164

Flange Pressure (bar)	Size Inch	Pipe Size	Flange ISO 6164	Insert*	Sleeve
400	2	50X3.0	F37-432-CFX	IN32-50X3.0T...	SL32-60-50-CFX
	2	50X5.0	F37-432-CFX	IN32-50X5.0T...	SL32-60-50-CFX
	2	50X6.0	F37-432-CFX	IN32-50X6.0T...	SL32-60-50-CFX
	2	60X3.0	F37-432-CFX	IN32-60X3.0T...	
	2	60X5.0	F37-432-CFX	IN32-60X5.0T...	
	2	60X6.0	F37-432-CFX	IN32-60X6.0T...	
	2 1/2	60X3.0	F37-440-CFX	IN40-60X3.0T...	SL40-75-60-CFX
	2 1/2	60X5.0	F37-440-CFX	IN40-60X5.0T...	SL40-75-60-CFX
	2 1/2	60X6.0	F37-440-CFX	IN40-60X6.0T...	SL40-75-60-CFX
	2 1/2	73X7.0	F37-44073-CF	IN40-73X7.0T...	
	2 1/2	75X3.0	F37-440-CFX	IN40-75X3.0T...	
	2 1/2	75X5.0	F37-440-CFX	IN40-75X5.0T...	
	3	75X3.0	F37-448-CFX	IN48-75X3.0T...	SL48-90-75-CFX
	3	75X5.0	F37-448-CFX	IN48-75X5.0T...	SL48-90-75-CFX
	3	90X3.5	F37-448-CFX	IN48-90X3.5T...	
	3	90X5.0	F37-448-CFX	IN48-90X5.0T...	
	3	90X9.0	F37-448909-CF	IN48-90X9.0T...	

Select the complete version:

- * ...FBCF Bonded Seal version
- ...FVCF F37 Seal version
- ...TCF Tube to Tube version
- ...FCF Flat Face version

Other sizes like schedule on request.

Bolts and nuts are not included in complete part numbers.
For recommended bolts and nuts see page 168.

R - Retaining ring flange | ISO 6164 footprint

ISO 6164

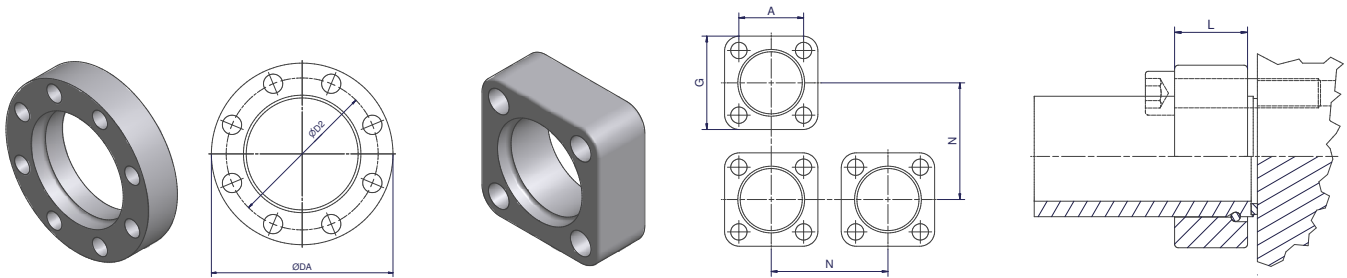

Retaining ring flange dimensions

Size Inch	Flange Order Code	A	G	N	L	Weight body (Steel) kg/1 piece	W.P. bar
2	R-432-CFX	69.3	100	105	40	1.60	400
2 1/2	R-440-CFX	83.4	120	125	50	2.90	
3	R-448-CFX	102.5	150	155	52	5.00	
4	R-464-CFX	123.7	180	185	70	9.70	
		D2	DA				
4 1/2	R-872-CFX	175.0	214		60	8.97	350
5	R-880-CFX	205.0	245		70	13.44	350
6	R-896-CFX	245.0	300		80	21.22	350
8	R-8128-350-TZNX	315.0	385		92	39.73	350
8	R-8128219.1-350-TZNX	290.0	350		92	35.56	350
10	R-8160273-350-TZNX	375.0	450		120	79.57	350
12	R-8192323.9-250-TZNX	440.0	520		120	96.81	250

Pressure rates related to flanges.
Other sizes like schedule on request.

Please change suffixes according to material/surface required

Order code suffixes		
Material	Suffix surface and material	Example
Steel, zinc plated, Cr(VI)-free	CF	R-432-CFX
Stainless steel	SS	R-432-SSX
Galvanized hot dip zinc	TZN	R-432-TZNX
Duplex	DPL	R-432-DPLX

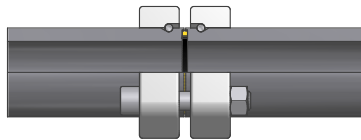

Part combination Bonded seal ISO 6164 connection

Flange pressure (bar)	Size Inch	Pipe Size	Flange	Retaining Ring	Bonded Seal
400	2	66X8.5	R-432-CFX	R32X	BS32SNX
	2 1/2	80X10.0	R-440-CFX	R40X	BS40SNX
	3	97X12.0	R-448-CFX	R48X	BS48SNX
	4	115X15.0	R-464-CFX	R64X	BS64SNX
350	4 1/2	130X15.0	R-872-CFX	R72X	BS72SNX
	5	150X15.0	R-880-CFX	R80X	BS80SNX

Bolts and nuts are not included in complete part numbers.
For recommended bolts and nuts see page 168.

PSC – Pipe seal carrier | ISO 6164 footprint

ISO 6164

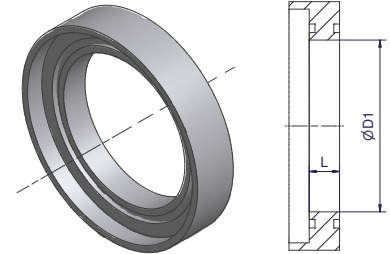

Size Inch	Pipe size	Seal carrier incl. F37 Seal	Seal carrier incl. O-Ring	L	D1	F37 Seal	O-Ring
2	66X8.5	PSC32-66X8.5VCF	PSC32-66X8.5OCF	10.0	49	F37RS32X	OR55.25X2.62X
2 1/2	80X10.0	PSC40-80X10VCF	PSC40-80X10OCF	15.0	60	F37RS40X	OR66.27X3.53X
	97X12.0	PSC48-97X12VCF	PSC48-97X12OCF	15.0	73	F37RS48X	OR78.97X3.53X
4	115X15.0	PSC64-115X15VCF	PSC64-115X15OCF	15.0	85	F37RS64X	OR94.84X3.53X
4 1/2	130X15.0	PSC72-130X15VCF	PSC72-130X15OCF	25.5	100	F37RS72X	OR107.54X3.53X
	150X15.0	PSC80-150X15VCF	PSC80-150X15OCF	38.0	120	F37RS80X	OR129.77X3.53X
6	190X20.0	PSC96-190X20VCF	PSC96-190X20OCF	40.0	150	F37RS96X	OR164.47X5.33X
8	250X25.0	PSC128-250X25VCF	PSC128-250X25OCF	40.0	200	F37RS128X	OR215.27X5.33X
8	219.1X22	on request	PSC128-219.1X22ODPL	40.0	175	on request	OR189.87X5.33X
10	273X25.4	on request	PSC160-273X25.4ODPL	40.0	222	on request	OR234.34X5.33X
12	323.9X33.32	on request	on request				

Other sizes on request.

Please change suffixes according to material/surface required

Order code suffixes		
Material	Suffix surface and material	Example
Steel, zinc plated, Cr(VI)-free, F37-Seal	VCF	PSC40-80X10VCF
Stainless steel, F37-Seal	VSS	PSC40-80X10VSS
Steel, zinc plated, Cr(VI)-free, O-Ring (NBR)	OCF	PSC40-80X10OCF
Stainless steel, O-Ring (NBR)	OSS	PSC40-80X10OSS
Duplex, O-Ring (NBR)	ODPL	PSC160-273X25.4ODPL

Example of part combination Pipe seal carrier ISO 6164 connection

Flange pressure (bar)	Size Inch	Pipe Size	Flange	Retaining Ring	Pipe seal carrier
400	2	66X8.5	R-432-CFX	R32X	PSC32-66X8.5VCF
	2 1/2	80X10.0	R-440-CFX	R40X	PSC40-80X10VCF
	3	97X12.0	R-448-CFX	R48X	PSC48-97X12VCF
	4	115X15.0	R-464-CFX	R64X	PSC64-115X15VCF
350	4 1/2	130X15.0	R-872-CFX	R72X	PSC72-130X15VCF
	5	150X15.0	R-880-CFX	R80X	PSC80-150X15VCF
	6	190X20.0	R-896-CFX	R96X	PSC96-190X20VCF
	8	250X25.0	R-8128-350-TZNX	RS128X	PSC128-250X25VCF
	8	219.1X22	R-8128219.1-350-TZNX	RS128/219.1X	PSC128-219.1X22ODPL
10	273X25.4	R-8160273-CFX	RS160X	PSC160-273X25.4ODPL	
250	12	323.9X33.32	R-8192323.9-250-TZNX	RS192/323.9X	on request

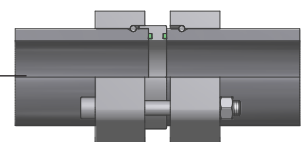

Other sizes on request

Bolts and nuts are not included in a complete part. For recommended bolts and nuts see page 168.



TFB - Flare flange connection

Tube to port connection, bonded seal

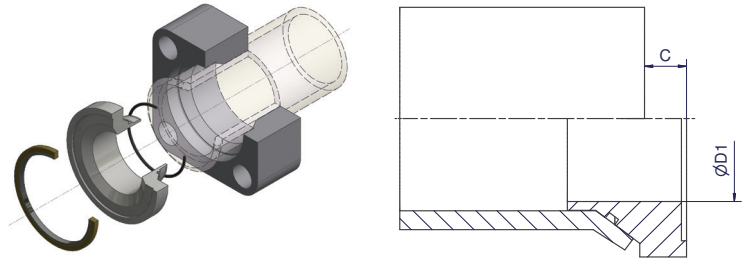

Size		Flange* incl. Insert + Bonded Seal + O-Ring Order code	D1	C	Insert incl. Bonded Seal + O-Ring Order code	Bonded Seal Order code	O-Ring Order code	Weight (Steel) kg/1kit
Inch	Tube							
2	50X3.0	F37-432-50X3.0TFBCF	42	11	IN32-50X3.0TFBCF	BS32SNX	OR44.17X1.78X	2.02
2	50X5.0	F37-432-50X5.0TFBCF	38	10	IN32-50X5.0TFBCF	BS32SNX	OR41X1.78X	2.04
2	50X6.0	F37-432-50X6.0TFBCF	35	10	IN32-50X6.0TFBCF	BS32SNX	OR41X1.78X	2.07
2	60X3.0	F37-432-60X3.0TFBCF	46	12	IN32-60X3.0TFBCF	BS32SNX	OR53.7X1.78X	2.07
2	60X5.0	F37-432-60X5.0TFBCF	46	11	IN32-60X5.0TFBCF	BS32SNX	OR50.52X1.78X	2.04
2	60X6.0	F37-432-60X6.0TFBCF	46	11	IN32-60X6.0TFBCF	BS32SNX	OR47.37X1.78X	2.03
2 1/2	60X3.0	F37-440-60X3.0TFBCF	50	12	IN40-60X3.0TFBCF	BS40SNX	OR53.7X1.78X	3.35
2 1/2	60X5.0	F37-440-60X5.0TFBCF	46	11	IN40-60X5.0TFBCF	BS40SNX	OR50.52X1.78X	3.36
2 1/2	60X6.0	F37-440-60X6.0TFBCF	46	11	IN40-60X6.0TFBCF	BS40SNX	OR47.37X1.78X	3.34
2 1/2	73X7.0	F37-440-73X7.0TFBCF	56	13	IN40-73X7.0TFBCF	BS40SNX	OR63.22X1.78X	3.33
2 1/2	75X3.0	F37-440-75X3.0TFBCF	60	10	IN40-75X3.0TFBCF	BS40SNX	OR69.57X1.78X	3.30
2 1/2	75X5.0	F37-440-75X5.0TFBCF	60	10	IN40-75X5.0TFBCF	BS40SNX	OR63.22X1.78X	3.32
3	75X3.0	F37-448-75X3.0TFBCF	66	10	IN48-75X3.0TFBCF	BS48SNX	OR69.57X1.78X	5.83
3	75X5.0	F37-448-75X5.0TFBCF	62	10	IN48-75X5.0TFBCF	BS48SNX	OR63.22X1.78X	5.99
3	90X3.5	F37-448-90X3.5TFBCF	72	15	IN48-90X3.5TFBCF	BS48SNX	OR82.27X1.78X	6.00
3	90X5.0	F37-448-90X5.0TFBCF	72	14	IN48-90X5.0TFBCF	BS48SNX	OR79X1.78X	5.96
3	90X9.0	F37-448-90X9.0TFBCF	69	17	IN48-90X9.0TFBCF	BS48SNX	OR72.75X1.78X	5.91

Other sizes on request. *Incl. adapter sleeve or jump size flange if necessary.

Please change suffixes according to material/surface required

Order code suffixes			
Material	Suffix surface and material	Example	Comments
Steel, zinc plated, Cr(VI)-free	CF	IN24-50X5.0TFBCF	
Stainless steel	SS	IN24-50X5.0TFBSS	

TFV - Flare flange connection

Tube to port connection, F37 seal

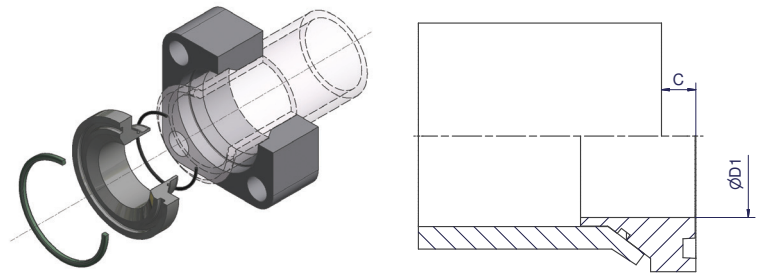

Size		Flange* incl. Insert + F37 Seal + O-Ring Order code	D1	C	Insert incl. F37 Seal + O-Ring Order code	F37 Seal Order code	O-Ring Order code	Weight (Steel) kg/1 kit
Inch	Tube							
2	50X3.0	F37-432-50X3.0TFVCF	42	11	IN32-50X3.0TFVCF	F37S32X	OR44.17X1.78X	2.02
2	50X5.0	F37-432-50X5.0TFVCF	38	10	IN32-50X5.0TFVCF	F37S32X	OR41X1.78X	2.04
2	50X6.0	F37-432-50X6.0TFVCF	35	10	IN32-50X6.0TFVCF	F37S32X	OR41X1.78X	2.07
2	60X3.0	F37-432-60X3.0TFVCF	46	12	IN32-60X3.0TFVCF	F37S32X	OR53.7X1.78X	2.07
2	60X5.0	F37-432-60X5.0TFVCF	46	11	IN32-60X5.0TFVCF	F37S32X	OR50.52X1.78X	2.04
2	60X6.0	F37-432-60X6.0TFVCF	46	11	IN32-60X6.0TFVCF	F37S32X	OR47.37X1.78X	2.03
2 1/2	60X3.0	F37-440-60X3.0TFVCF	50	12	IN40-60X3.0TFVCF	F37S40X	OR53.7X1.78X	3.35
2 1/2	60X5.0	F37-440-60X5.0TFVCF	46	11	IN40-60X5.0TFVCF	F37S40X	OR50.52X1.78X	3.36
2 1/2	60X6.0	F37-440-60X6.0TFVCF	46	11	IN40-60X6.0TFVCF	F37S40X	OR47.37X1.78X	3.34
2 1/2	73X7.0	F37-440-73X7.0TFVCF	56	13	IN40-73X7.0TFVCF	F37S40X	OR63.22X1.78X	3.33
2 1/2	75X3.0	F37-440-75X3.0TFVCF	60	10	IN40-75X3.0TFVCF	F37S40X	OR69.57X1.78X	3.30
2 1/2	75X5.0	F37-440-75X5.0TFVCF	60	10	IN40-75X5.0TFVCF	F37S40X	OR63.22X1.78X	3.32
3	75X3.0	F37-448-75X3.0TFVCF	66	10	IN48-75X3.0TFVCF	F37S48X	OR69.57X1.78X	5.83
3	75X5.0	F37-448-75X5.0TFVCF	62	10	IN48-75X5.0TFVCF	F37S48X	OR63.22X1.78X	5.99
3	90X3.5	F37-448-90X3.5TFVCF	72	15	IN48-90X3.5TFVCF	F37S48X	OR82.27X1.78X	6.00
3	90X5.0	F37-448-90X5.0TFVCF	72	14	IN48-90X5.0TFVCF	F37S48X	OR79X1.78X	5.96
3	90X9.0	F37-448-90X9.0TFVCF	69	17	IN48-90X9.0TFVCF	F37S48X	OR72.75X1.78X	5.82

Other sizes on request. *Incl. adapter sleeve or jump size flange if necessary.

Please change suffixes according to material/surface required

Order code suffixes		
Material	Suffix surface and material	Example
Steel, zinc plated, Cr(VI)-free	CF	IN32-50X5.0TFVCF
Stainless steel	SS	IN32-50X5.0TFVSS



TT - Flare Flange Connection

Tube to tube connection

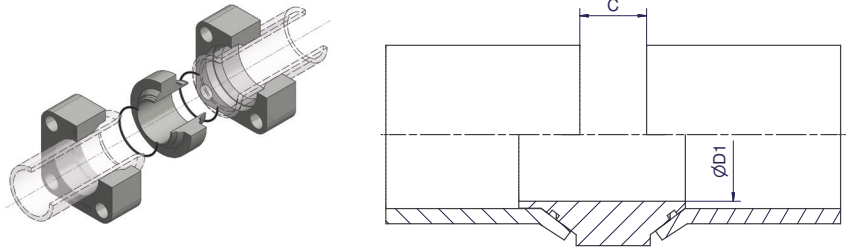

Size		2 Flanges* incl. Insert + 2 x O-Ring Order code	D1	C	Insert incl. 2 x O-Ring Order code	O-Ring Order code	Weight (Steel) kg/1 kit
Inch	Tube						
2	50X3.0	F37-432-50X3.0TTCF	42	22	IN32-50X3.0TTCF	OR44.17X1.78X	3.82
2	50X5.0	F37-432-50X5.0TTCF	38	20	IN32-50X5.0TTCF	OR41X1.78X	3.93
2	50X6.0	F37-432-50X6.0TTCF	35	20	IN32-50X6.0TTCF	OR41X1.78X	3.98
2	60X3.0	F37-432-60X3.0TTCF	46	24	IN32-60X3.0TTCF	OR53.7X1.78X	3.95
2	60X5.0	F37-432-60X5.0TTCF	46	22	IN32-60X5.0TTCF	OR50.52X1.78X	3.88
2	60X6.0	F37-432-60X6.0TTCF	46	22	IN32-60X6.0TTCF	OR47.37X1.78X	3.87
2 1/2	60X3.0	F37-440-60X3.0TTCF	50	24	IN40-60X3.0TTCF	OR53.7X1.78X	6.25
2 1/2	60X5.0	F37-440-60X5.0TTCF	46	22	IN40-60X5.0TTCF	OR50.52X1.78X	6.26
2 1/2	60X6.0	F37-440-60X6.0TTCF	45	22	IN40-60X6.0TTCF	OR47.37X1.78X	6.24
2 1/2	73X7.0	F37-440-73X7.0TTCF	56	26	IN40-73X7.0TTCF	OR63.22X1.78X	6.23
2 1/2	75X3.0	F37-440-75X3.0TTCF	60	20	IN40-75X3.0TTCF	OR69.57X1.78X	6.20
2 1/2	75X5.0	F37-440-75X5.0TTCF	60	20	IN40-75X5.0TTCF	OR63.22X1.78X	6.22
3	75X3.0	F37-448-75X3.0TTCF	66	20	IN48-75X3.0TTCF	OR69.57X1.78X	10.83
3	75X5.0	F37-448-75X5.0TTCF	62	20	IN48-75X5.0TTCF	OR63.22X1.78X	10.99
3	90X3.5	F37-448-90X3.5TTCF	72	30	IN48-90X3.5TTCF	OR82.27X1.78X	11.00
3	90X5.0	F37-448-90X5.0TTCF	72	28	IN48-90X5.0TTCF	OR79X1.78X	10.96
3	90X9.0	F37-448-90X9.0TTCF	69	34	IN48-90X9.0TTCF	OR72.75X1.78X	10.85

Other sizes on request. *Incl. adapter sleeve or jump size flange if necessary.

Please change suffixes according to material/surface required

Order code suffixes		
Material	Suffix surface and material	Example
Steel, zinc plated, Cr(VI)-free	CF	IN32-50X5.0TTCF
Stainless steel	SS	IN32-50X5.0TTSS

TF – Flare Flange Connection

Tube to port connection, flat face

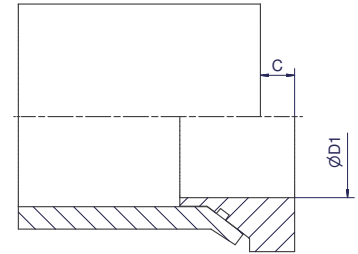
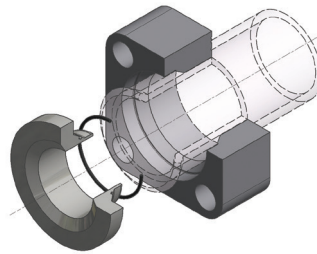

Size		Flange* incl. Insert + O-Ring Order code	D1	C	Insert incl. O-Ring Order code	O-Ring Order code	Weight (Steel) kg/1 kit
Inch	Tube						
2	50X3.0	F37-432-50X3.0TFCF	42	11	IN32-50X3.0TFCF	OR44.17X1.78X	2.02
2	50X5.0	F37-432-50X5.0TFCF	38	10	IN32-50X5.0TFCF	OR41X1.78X	2.04
2	50X6.0	F37-432-50X6.0TFCF	35	10	IN32-50X6.0TFCF	OR41X1.78X	2.07
2	60X3.0	F37-432-60X3.0TFCF	46	12	IN32-60X3.0TFCF	OR53.7X1.78X	2.07
2	60X5.0	F37-432-60X5.0TFCF	46	11	IN32-60X5.0TFCF	OR50.52X1.78X	2.04
2	60X6.0	F37-432-60X6.0TFCF	46	11	IN32-60X6.0TFCF	OR47.37X1.78X	2.03
2 1/2	60X3.0	F37-440-60X3.0TFCF	50	12	IN40-60X3.0TFCF	OR53.7X1.78X	3.35
2 1/2	60X5.0	F37-440-60X5.0TFCF	46	11	IN40-60X5.0TFCF	OR50.52X1.78X	3.36
2 1/2	60X6.0	F37-440-60X6.0TFCF	46	11	IN40-60X6.0TFCF	OR47.37X1.78X	3.34
2 1/2	73X7.0	F37-440-73X7.0TFCF	56	13	IN40-73X7.0TFCF	OR63.22X1.78X	3.33
2 1/2	75X3.0	F37-440-75X3.0TFCF	60	10	IN40-75X3.0TFCF	OR69.57X1.78X	3.30
2 1/2	75X5.0	F37-440-75X5.0TFCF	60	10	IN40-75X5.0TFCF	OR63.22X1.78X	3.32
3	75X3.0	F37-448-75X3.0TFCF	66	10	IN48-75X3.0TFCF	OR69.57X1.78X	5.83
3	75X5.0	F37-448-75X5.0TFCF	62	10	IN48-75X5.0TFCF	OR63.22X1.78X	5.99
3	90X3.5	F37-448-90X3.5TFCF	72	15	IN48-90X3.5TFCF	OR82.27X1.78X	6.00
3	90X5.0	F37-448-90X5.0TFCF	72	14	IN48-90X5.0TFCF	OR79X1.78X	5.96
3	90X9.0	F37-448-90X9.0TFCF	69	17	IN48-90X9.0TFCF	OR72.75X1.78X	5.82

Other sizes on request. *Incl. adapter sleeve or jump size flange if necessary.

Please change suffixes according to material/surface required

Order code suffixes		
Material	Suffix surface and material	Example
Steel, zinc plated, Cr(VI)-free	CF	IN32-50X5.0TFCF
Stainless steel	SS	IN32-50X5.0TFSS



SL - Sleeve

ISO 6164

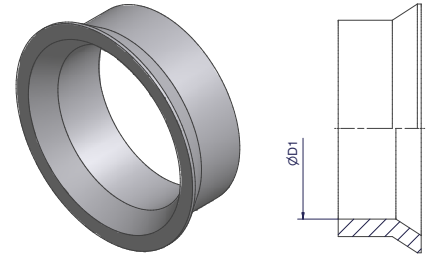

Size Inch	Tube OD	Order code	D1	Weight body (Steel) kg/1 piece
2	50	SL32-60-50-CFX	50.30	0.16
2 1/2	60	SL40-75-60-CFX	60.45	0.36
3	75	SL48-90-75-CFX	75.45	0.52

Please change suffixes according to material/surface required

Order code suffixes		
Material	Suffix surface and material	Example
Steel, zinc plated, Cr(VI)-free	CF	SL24-50-42-CFX
Stainless steel	SS	SL24-50-42-SSX

R – Retaining ring

ISO 6164

Size Inch	Tube	Order code	D	S
2	66X8.5	R32X	61.3	5.0
2 1/2	80X10.0	R40X	75.3	5.0
3	97X12.0	R48X	91.3	6.0
4	115X15.0	R64X	107.3	8.0
4 1/2	130x15.0	R72X	122.3	8.0
5	150X15.0	R80X	142.3	8.0
6	190x20.0	R96X	180.3	10.0
8	250X25.0	RS128X	236.0	12.0
8	219.1X22	RS128/219.1X	205.1	12.0
10	273X25.4	RS160X	259.0	12.0
12	323.9X33.32	RS192/323.9X	309.9	12.0

Material: Stainless steel

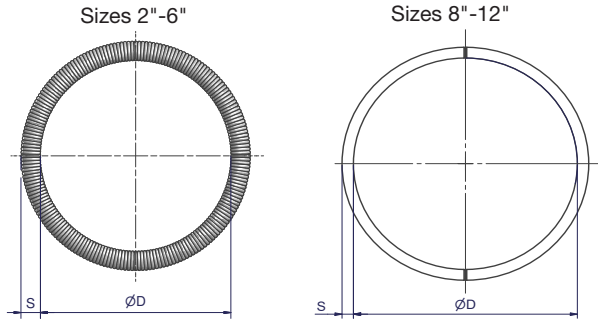

MTF-R - Male thread adapter, BSPP

ISO 6164

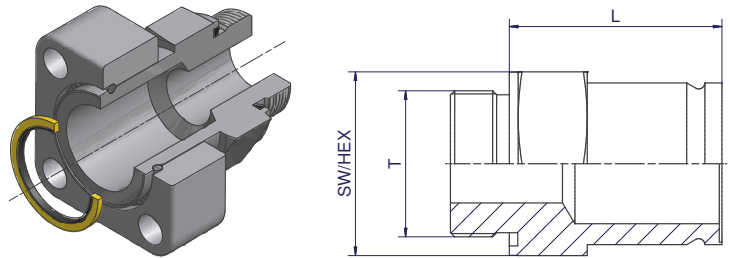

Size Inch	Tube	Complete part Order code	Body incl. ED Seal Order code	L	T (BSPP)	SW/ HEX	Weight body (Steel) kg/1 piece
2	66X8.5	R-432MTFRCF	MTF32ROMDCF	104.0	G 2 A	75	1.90
2	66X8.5	R-440MTFR112CF	MTFR32R112OMDCF	103.5	G 1 1/2 A	75	1.80
2 1/2	80X10.0	R-440MTFRCF	MTFR40ROMDCF	134.0	G 2 1/2 A	85	3.50
2 1/2	80X10.0	R-440MTFR2CF	MTFR40R2OMDCF	136.0	G 2 A	85	3.50
3	97X12.0	R-448MTFRCF	MTFR48ROMDCF	145.0	G 3 A	95	5.00

Other sizes on request.

Please change suffixes according to material/surface required

Order code suffixes		
Material	Suffix surface and material	Example
Steel, zinc plated, Cr(VI)-free	CF	R-432MTFRCF
Stainless steel	SS	R-432MTFRSS

MTF-N - Male thread adapter, NPT

ISO 6164

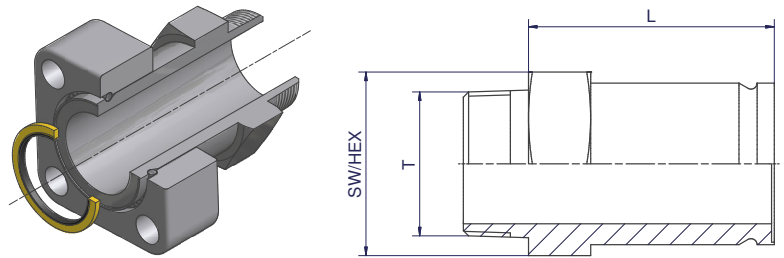

Size Inch	Tube	Complete part Order code	Body incl. ED Seal Order code	L	T (NPT)	SW/ HEX	Weight body (Steel) kg/1 piece
2	66X8.5	R-432MTFNCF	MTF32NCFX	100.4	2-11.5	75	2.40
2 1/2	80X10.0	R-440MTFNCF	MTF40NCFX	130.0	2 1/2-8	85	3.40
3	97X12.0	R-448MTFNCF	MTF48NCFX	141.2	3-8	95	4.90

Other sizes on request.

Please change suffixes according to material/surface required

Order code suffixes		
Material	Suffix surface and material	Example
Steel, zinc plated, Cr(VI)-free	CF	R-432MTFNCF
Stainless steel	SS	R-432MTFNSS



FTF-R - Female thread adapter, BSPP

ISO 6164

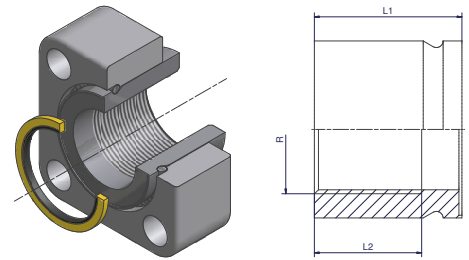

Size Inch	Tube	Complete part Order code	Body Order code	L1	L2	R (BSPP)	Weight body (Steel) kg/1 piece
2	66X8.5	R-432FTFRCF	FTF32RCFX	55	40	G 1 1/2	0.75
2 1/2	80X10.0	R-440FTFRCF	FTF40RCFX	80	40	G 2	1.52
3	97X12.0	R-448FTFRCF	FTF48RCFX	85	50	G 2 1/2	2.11

Other sizes on request.

Please change suffixes according to material/surface required

Order code suffixes		
Material	Suffix surface and material	Example
Steel, zinc plated, Cr(VI)-free	CF	R-432FTFRCF
Stainless steel	SS	R-432FTFRSS

WA – Weld adapter connection

ISO 6164

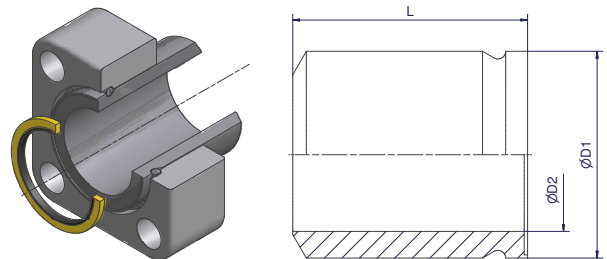

Size Inch	Tube	Complete Part Order code	Retaining Ring	Bonded Seal	Flange Order code	Weld Adapter Body Order code	D1	D2	L	Weight (Steel) kg/1 kit
2	48.3X5.6	R-432WA-48.3X5.6S	R32X	BS32SNX	R-432-CFX	WA32-48.3X5.6SX	66	37	90	2.90
2	50X9.0	R-432WA-50X9.0S	R32X	BS32SNX	R-432-CFX	WA32-50X9.0SX	66	32	90	3.11
2	60X3.0	R-432WA-60X3.0S	R32X	BS32SNX	R-432-CFX	WA32-60X3.0SX	66	49	90	2.39
2	60X5.0	R-432WA-60X5.0S	R32X	BS32SNX	R-432-CFX	WA32-60X5.0SX	66	50	90	2.49
2	60X6.0	R-432WA-60X6.0S	R32X	BS32SNX	R-432-CFX	WA32-60X6.0SX	66	48	90	2.60
2	60X8.0	R-432WA-60X8.0S	R32X	BS32SNX	R-432-CFX	WA32-60X8.0SX	66	44	90	2.78
2	60X10.0	R-432WA-60X10.0S	R32X	BS32SNX	R-432-CFX	WA32-60X10.0SX	66	40	90	2.96
2	60.3X2.8	R-432WA-60.3X2.8S	R32X	BS32SNX	R-432-CFX	WA32-60.3X2.8SX	66	49	90	2.37
2	60.3X3.9	R-432WA-60.3X3.9S	R32X	BS32SNX	R-432-CFX	WA32-60.3X3.9SX	66	49	90	2.45
2	60.3X5.5	R-432WA-60.3X5.5S	R32X	BS32SNX	R-432-CFX	WA32-60.3X5.5SX	66	49	90	2.54
2	60.3X8.7	R-432WA-60.3X8.7S	R32X	BS32SNX	R-432-CFX	WA32-60.3X8.7SX	66	43	90	2.84
2	60.3X11.1	R-432WA-60.3X11.1S	R32X	BS32SNX	R-432-CFX	WA32-60.3X11.1SX	66	38	90	3.04
2	66X8.5	R-432WA-66X8.5S	R32X	BS32SNX	R-432-CFX	WA32-66X8.5SX	66	49	75	2.45
2 1/2	65X8.0	R-440WA-65X8.0S	R40X	BS40SNX	R-440-CFX	WA40-65X8.0SX	80	49	105	5.10
2 1/2	65X8.5	R-440WA-65X8.5S	R40X	BS40SNX	R-440-CFX	WA40-65X8.5SX	80	59	105	4.59
2 1/2	73X7.0	R-440WA-73X7.0S	R40X	BS40SNX	R-440-CFX	WA40-73X7.0SX	80	59	105	4.20
2 1/2	75X5.0	R-440WA-75X5.0S	R40X	BS40SNX	R-440-CFX	WA40-75X5.0SX	80	60	105	4.37
2 1/2	76.1X6.3	R-440WA-76.1X6.3S	R40X	BS40SNX	R-440-CFX	WA40-76.1X6.3SX	80	60	105	4.45
2 1/2	76.1X12.5	R-440WA-76.1X12.5S	R40X	BS40SNX	R-440-CFX	WA40-76.1X12.5SX	80	51	105	5.17
2 1/2	80X10.0	R-440WA-80X10.0S	R40X	BS40SNX	R-440-CFX	WA40-80X10.0SX	80	60	90	4.40
3	76.1X12.5	R-448WA-76.1X12.5S	R48X	BS48SNX	R-448-CFX	WA48-76.1X12.5SX	97	51	120	8.18
3	80X10.0	R-448WA-80X10.0S	R48X	BS48SNX	R-448-CFX	WA48-80X10.0SX	97	60	120	8.07
3	88.9X3.1	R-448WA-88.9X3.1S	R48X	BS48SNX	R-448-CFX	WA48-88.9X3.1SX	97	73	120	7.18
3	88.9X5.5	R-448WA-88.9X5.5S	R48X	BS48SNX	R-448-CFX	WA48-88.9X5.5SX	97	73	120	7.47
3	88.9X7.7	R-448WA-88.9X7.7S	R48X	BS48SNX	R-448-CFX	WA48-88.9X7.7SX	97	74	120	7.67
3	88.9X8.8	R-448WA-88.9X8.8S	R48X	BS48SNX	R-448-CFX	WA48-88.9X8.8SX	97	71	120	7.90
3	88.9X11.1	R-448WA-88.9X11.1S	R48X	BS48SNX	R-448-CFX	WA48-88.9X11.1SX	97	67	120	8.34
3	88.9X12.5	R-448WA-88.9X12.5S	R48X	BS48SNX	R-448-CFX	WA48-88.9X12.5SX	97	64	120	8.60
3	88.9X15.2	R-448WA-88.9X15.2S	R48X	BS48SNX	R-448-CFX	WA48-88.9X15.2SX	97	59	120	9.00
3	90X3.5	R-448WA-90X3.5S	R48X	BS48SNX	R-448-CFX	WA48-90X3.5SX	97	73	120	7.19
3	90X5.0	R-448WA-90X5.0S	R48X	BS48SNX	R-448-CFX	WA48-90X5.0SX	97	73	120	7.50
3	90X9.0	R-448WA-90X9.0S	R48X	BS48SNX	R-448-CFX	WA48-90X9.0SX	97	72	120	7.85
3	97X12.0	R-448WA-97X12.0S	R48X	BS48SNX	R-448-CFX	WA48-97X12.0SX	97	73	110	7.65
4	100X4.0	R-464WA-100X4.0S	R64X	BS64SNX	R-464-CFX	WA64-100X4.0SX	115	85	130	13.44
4	101.6X8.1	R-464WA-101.6X8.1S	R64X	BS64SNX	R-464-CFX	WA64-101.6X8.1SX	115	85	130	12.49
4	101.6X16.0	R-464WA-101.6X16.0S	R64X	BS64SNX	R-464-CFX	WA64-101.6X16.0SX	115	85	120	13.73
4	114.3X4.5	R-464WA-114.3X4.5S	R64X	BS64SNX	R-464-CFX	WA64-114.3X4.5SX	115	80	120	14.40
4	114.3X12.5	R-464WA-114.3X12.5S	R64X	BS64SNX	R-464-CFX	WA64-114.3X12.5SX	115	85	120	12.37
4	114.3X17.1	R-464WA-114.3X17.1S	R64X	BS64SNX	R-464-CFX	WA64-114.3X17.1SX	115	85	120	13.90
4	115X4.0	R-464WA-115X4.0S	R64X	BS64SNX	R-464-CFX	WA64-115X4.0SX	115	85	120	12.36
4	115X15.0	R-464WA-115X15.0S	R64X	BS64SNX	R-464-CFX	WA64-115X15.0SX	115	85	120	13.87
4 1/2	130X15.0	R-872WA-130X15.0S	R72X	BS72SNX	R-872-CFX	WA72-130X15SX	130	100	125	14.02
5	150X15.0	R-880WA-150X15.0S	R80X	BS80SNX	R-880-CFX	WA80-150X15SX	150	120	110	18.55
6	190X20.0	R-896WA-190X20.0S	R96X	PSC96-190x20CFX	R-896-CFX	WA96-190x20.0SX	190	150	175	32.70

Other sizes on request.

Please change suffixes according to material/surface required

Order code suffixes		
Material	Suffix surface and material	Example
Steel	S	R-432WA-66X8.5S
Stainless steel	SS	R-432WA-66X8.5SS



BF - Bulkhead flange

ISO 6164

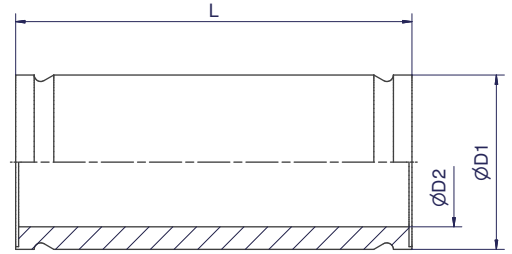
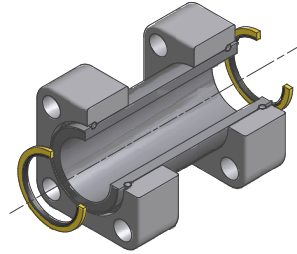

Size Inch	Complete Part Order code	Bulkhead Body Order code	D1	D2	L	Weight body (Steel) kg/1 piece
2	R-432BFS	BF32SX	66	49	210	2.45
2 1/2	R-440BFS	BF40SX	80	60	220	3.70
3	R-448BFS	BF48SX	97	73	240	7.85
4	R-464BFS	BF64SX	115	85	260	9.35
5	R-880BFS	BF80SX	150	120	260	10.53

Other sizes on request.

Please change suffixes according to material/surface required

Order code suffixes		
Material	Suffix surface and material	Example
Steel	S	R-432BFS
Stainless steel	SS	R-432BFSS

RF – Reducer flange

ISO 6164

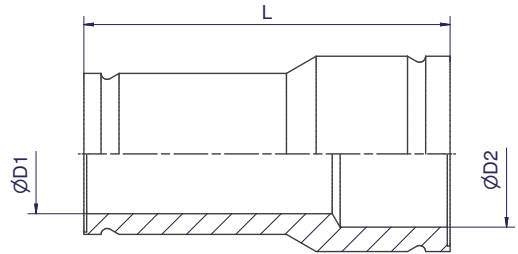
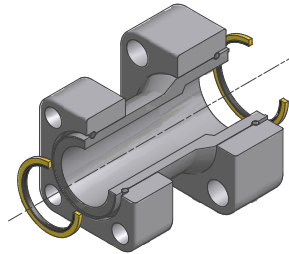

Size Inch	Complete Part Order code	Reducer Body Order code	D1	D2	L	Weight body (Steel) kg/1 piece
2 1/2 - 2	R-440-432RFCF	RF40-32CFX	49	60	150	2.2
3 - 2	R-448-432RFCF	RF48-32CFX	49	73	180	3.4
3 - 2 1/2	R-448-440RFCF	RF48-40CFX	60	73	180	3.7
4 - 3	R-464-448RFCF	RF64-48CFX	73	85	200	6.1
5 - 3	R-880-448RFCF	RF80-48CFX	73	120	200	8.0
5 - 4	R-880-464RFCF	RF80-64CFX	85	120	220	10.3
6 - 5	R-896-880RFCF	RF96-80CFX	120	150	250	18.3

Other sizes on request.

Please change suffixes according to material/surface required

Order code suffixes		
Material	Suffix surface and material	Example
Steel, zinc plated, Cr(VI)-free	CF	R-432-424RFCF
Stainless steel	SS	R-432-424RFSS



FB90 - 90° Flange bend

ISO 6164

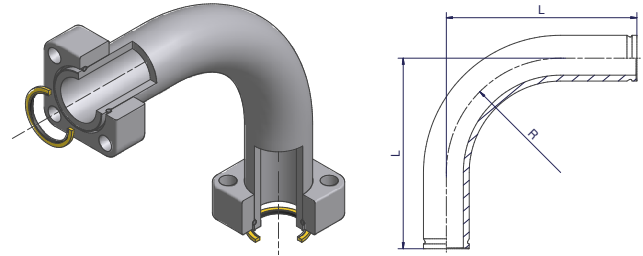

Size Inch	Tube	Complete Part Order code	90° Flange Bend Order code	L	R	Weight body (Steel) kg/1 piece
2	66X8.5	R-432FB90CF	FB90-32CFX	275	165	5.72
2 1/2	80X10.0	R-440FB90S*	FB90-40SX*	370	200	11.20
3	97X12.0	R-448FB90S*	FB90-48SX*	450	243	19.90

*only available as Steel version

Please change suffixes according to material/surface required

Order code suffixes			
Tube material	Suffix surface and material	Example	Comments
Steel, zinc plated, Cr(VI)-free	CF	R-432FB90CF	
Steel, black phpsphated	SX	R-440FB90S	
Stainless steel	SS	R-432FB90SS	on request

FB45 - 45° Flange bend

ISO 6164

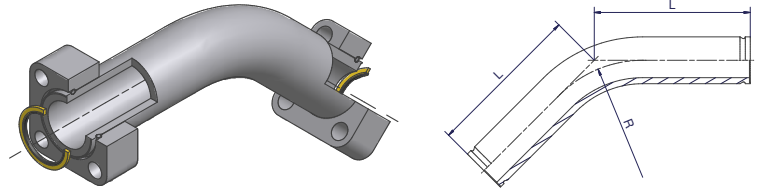

Size Inch	Tube	Complete Part Order code	45° Flange Bend Order code	L	R	Weight body (Steel) kg/1 piece
2	66X8.5	R-432FB45CF	FB45-32CFX	220	165	5.16
2 1/2	80X10.0	R-440FB45S	FB45-40SX	240	200	8.07
3	97X12.0	R-448FB45S	FB45-48SX	260	243	12.70

Available on request.

Please change suffixes according to material/surface required

Order code suffixes			
Tube material	Suffix surface and material	Example	Comments
Steel, zinc plated, Cr(VI)-free	CF	R-432FB45CF	
Steel, black phosphated	SX	R-440FB45S	
Stainless steel	SS	R-432FB45SS	on request



LF - Elbow flange

ISO 6164

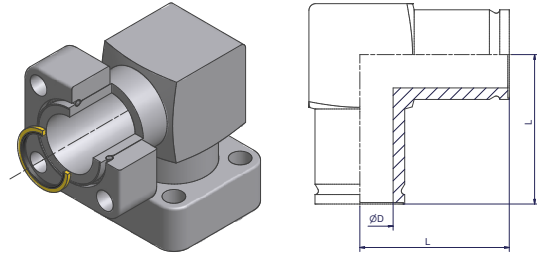

Size Inch	Complete Part Order code	Elbow Flange body Order code	D	L	Weight body (Steel) kg/1 piece
2	R-432LFCF	LF32CFX	49	110	4.02
2 1/2	R-440LFCF	LF40CFX	60	130	5.79
3	R-448LFCF	LF48CFX	73	160	10.76

Please change suffixes according to material/surface required

Order code suffixes		
Material	Suffix surface and material	Example
Steel, zinc plated, Cr(VI)-free	CF	R-432LFCF
Stainless steel	SS	R-432LFSS

TF - TEE flange

ISO 6164

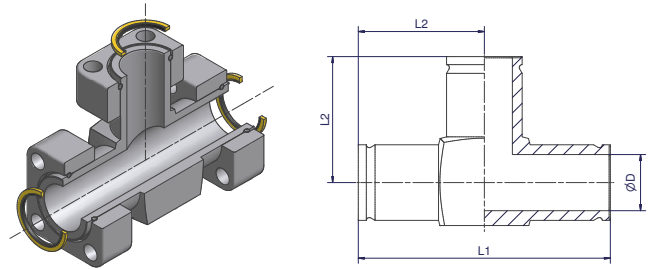

Size Inch	Complete Part Order code	Tee Flange body Order code	D	L1	L2	Weight body (Steel) kg/1 piece
2	R-432TFCF	TF32CFX	49	220	110	4.53
2 1/2	R-440TFCF	TF40CFX	60	260	130	8.70
3	R-448TFCF	TF48CFX	73	320	160	12.81

Please change suffixes according to material/surface required

Order code suffixes		
Material	Suffix surface and material	Example
Steel, zinc plated, Cr(VI)-free	CF	R-432TFCF
Stainless steel	SS	R-432TFSS



LB - Flange L-block

ISO 6164

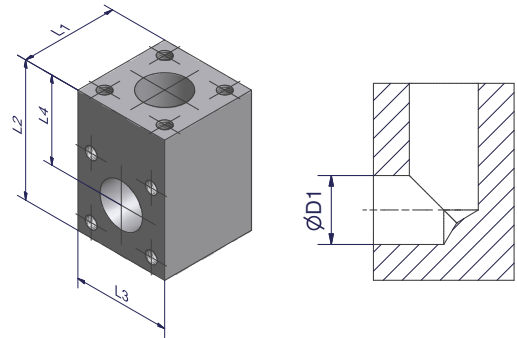

Size Inch	Order code	D1	L1	L2	L3	L4	Weight (Steel) kg/1 piece
2	LB432CFX	49	100	140	100	90	8.72
2 1/2	LB440CFX	60	120	160	120	100	14.10
3	LB448SX	73	150	200	150	125	28.10
4	LB464SX	85	180	240	180	150	48.60
5	LB880SX*	120	260	300	260	170	131.65
6	LB896SX*	150	300	360	300	210	203.00

Other sizes on request.
 Blocks only for use with F37 Components
 *only available as Steel version

Please change suffixes according to material/surface required

Order code suffixes		
Material	Suffix surface and material	Example
Steel, zinc plated, Cr(VI)-free	CF	LB432CFX *not in CF available
Steel	S	LB432SX
Stainless steel	SS	LB432SSX

TB - Flange T-block

ISO 6164

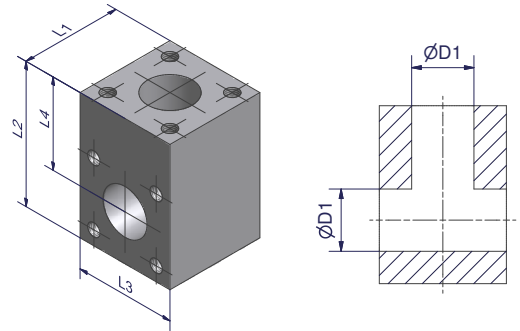

Size Inch	Order code	D1	L1	L2	L3	L4	Weight (Steel) kg/1 piece
2	TB432CFX	49	100	140	100	90	8.03
2 1/2	TB440CFX	60	120	160	120	100	12.90
3	TB448SX	73	150	200	150	125	25.80
4	TB464SX	85	180	240	180	150	40.70
4 1/2	TB872SX	100	220	250	220	140	74.00
5	TB880SX*	120	260	300	260	170	122.00
6	TB896SX*	150	300	360	300	210	186.00

Other sizes on request.
Blocks only for use with F37 Components

Please change suffixes according to material/surface required

Order code suffixes		
Material	Suffix surface and material	Example
Steel, zinc plated, Cr(VI)-free	CF	TB432CFX *not in CF available
Steel	S	TB432SX
Stainless steel	SS	TB432SSX



TBR - Flange T-block reducer

ISO 6164

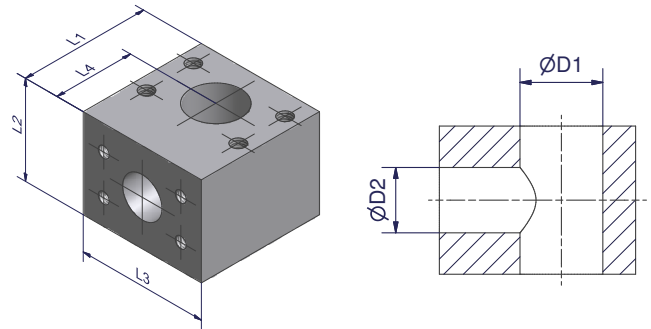

Size Inch	Order code	D1	D2	L1	L2	L3	L4	Weight (Steel) kg/1 piece
2 1/2 - 2	TBR440-432-440CFX	60	49	150	100	120	90	10.2
3 - 2 1/2	TBR448-440-448CFX	73	60	185	120	150	110	19.2
3 - 2	TBR448-432-448CFX	73	49	175	100	150	100	15.2
4 - 3	TBR464-448-464SX	85	73	225	180	180	135	35.2
4 - 2 1/2	TBR464-440-464SX	85	60	215	120	180	125	26.9
4 - 2	TBR464-432-464SX	85	49	200	100	180	110	21.0

Other sizes on request.
Bkocks only for use with F37 Components

Please change suffixes according to material/surface required

Order code suffixes		
Material	Suffix surface and material	Example
Steel, zinc plated, Cr(VI)-free	CF	TBR448-432-448CFX
Steel	S	TBR448-432-448SX
Stainless steel	SS	TBR448-432-448SSX

BFV - Blind flange

ISO 6164

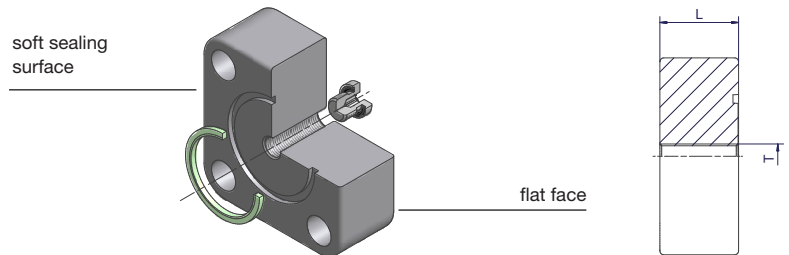

Size Inch	Flange incl. VSTI-ED and Soft Seal Order code	L	T	Weight (Steel) kg/1 piece
2	F37-432BFVCF	40.0	G 1/4	2.75
2 1/2	F37-440BFVCF	50.0	G 1/4	4.90
3	F37-448BFVCF	52.0	G 1/4	8.15
4	F37-464BFVCF	70.0	G 1/4	11.55
4 1/2	F37-872BFVCF	60.0	G 1/4	15.41
5	F37-880BFVCF	50.0	G 1/4	16.74
6	F37-896BFVCF	80.0	G 1/4	39.95
8	F37-8128BFVCF	92.0	G 1/4	76.87
10	F37-8160BFVCF	90.0	G 1/4	102.43

Other sizes on request.

Please change suffixes according to material/surface required

Order code suffixes		
Material	Suffix surface and material	Example
Steel, zinc plated, Cr(VI)-free	CF	F37-432BFVCF
Stainless steel	SS	F37-432BFVSS



BS - Bonded seal

ISO 6164

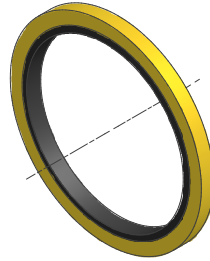

Size Inch	Steel	Stainless Steel
2	BS32SNX	BS32SSNX
2 1/2	BS40SNX	BS40SSNX
3	BS48SNX	BS48SSNX
4	BS64SNX	BS64SSNX
4 1/2	BS72SNX	BS72SSNX
5	BS80SNX	BS80SSNX

Sealing: NBR

Other sealing materials like FKM on request.

F37S/F37RS - F37 Seal

ISO 6164

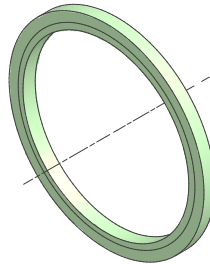

Size Inch	F37S (F37 seal for flaring system)	F37RS (F37 seal for retaining ring system)
2	F37S32X	F37RS32X
2 1/2	F37S40X	F37RS40X
3	F37S48X	F37RS48X
4	-	F37RS64X
4 1/2	-	F37RS72X
5	-	F37RS80X
6	-	F37RS96X
8	-	F37RS128X
10	-	F37RS160SCHXXSX

Other sizes on request.

Sealing: Polyurethane

Material properties and applications see page 20.

AO - Adapter bonded seal/F37 seal/O-Ring

ISO 6164

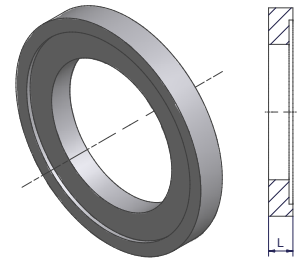

Size Inch	Adapter* Order code	L	Weight (Steel) kg/1 piece
2	AO32CFX	7	0.10
2 1/2	AO40CFX	7	0.14
3	AO48CFX	7	0.20
4	AO64CFX	7	0.35
4 1/2	AO72CFX	7	0.30
5	AO80CFX	7	0.32

*Part excluding seals.
For assembling add L to the corresponding bolt length.

Please change suffixes according to material/surface required

Order code suffixes		
Material	Suffix surface and material	Example
Steel, zinc plated, Cr(VI)-free	CF	AO32CFX
Stainless steel	SS	AO32SSX



TBT - Tee between bonded seal

ISO 6164

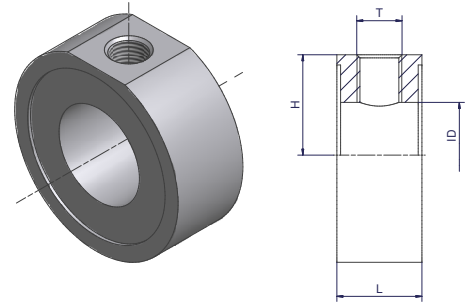

Size Inch	Order code	L	H	T	ID	Weight (Steel) kg/1 piece
2	TBT32-1/4CFX	25	35	G 1/4	41	0.51
2	TBT32-1/2CFX	40	34	G 1/2	38	0.87
2 1/2	TBT40-1/4CFX	30	42	G 1/4	60	0.63
3	TBT48-1/4CFX	30	50	G 1/4	72	0.90

*Part excluding seals.
For testpoints and diagnostic test equipment see catalogue 4100, Industrial Tube Fittings Europe.
For assembling add L to the corresponding bolt length.

Alternative versions on request.

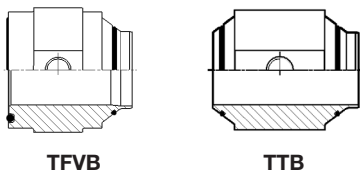

Please change suffixes according to material/surface required

Order code suffixes		
Material	Suffix surface and material	Example
Steel, zinc plated, Cr(VI)-free	CF	TBT32-1/2CFX
Stainless steel	SS	TBT32-1/2SSX

Bolts and nuts for flange

ISO 6164



F37 Flare Flange

Size Inch	Flange	F37 Seal/Flat Face/Bonded Seal		Nut
		Recommended bolts Tube to Port	Recommended bolts Tube to Tube	
2	F37-432-CFX	4 x ZYLS16X65	4 x ZYLS16X110	4 x ISO4032-M16
2 1/2	F37-440-CFX	4 x ZYLS20X80	4 x ZYLS20X140	4 x ISO4032-M20
3	F37-448-CFX	4 x ZYLS24X90	4 x ZYLS24X150	4 x ISO4032-M24
3	F37-448909-CFX	4 x ZYLS24X110	4 x ZYLS24X190	4 x ISO4032-M24

Retaining Ring Flange

Size Inch	Flange	Flat Face/Bonded Seal		Pipe Seal Carrier (PSC)		Nut
		Recommended bolts Tube to Port	Recommended bolts Tube to Tube	Recommended bolts Tube to Port	Recommended bolts Tube to Tube	
2	R-432-CFX	4 x ZYLS16X65	4 x ZYLS16X110	4 x ZYLS16X75	4 x ZYLS16X130	4 x ISO4032-M16
2 1/2	R-440-CFX	4 x ZYLS20X80	4 x ZYLS20X140	4 x ZYLS20X95	4 x ZYLS20X150	4 x ISO4032-M20
3	R-448-CFX	4 x ZYLS24X90	4 x ZYLS24X150	4 x ZYLS24X100	4 x ZYLS24X160	4 x ISO4032-M24
4	R-464-CFX	4 x ZYLS30X120	4 x ZYLS30X190	4 x ZYLS30X130	4 x ZYLS30X200	4 x ISO4032-M30
4 1/2	R-872-CFX	8 x ZYLS20X90	8 x ZYLS20X160	8 x ZYLS20X115	8 x ZYLS20X190	8 x ISO4032-M20
5	R-880-CFX	8 x ZYLS24X110	8 x ZYLS24X190	8 x ZYLS24X145	8 x ZYLS24X220	8 x ISO4032-M24
6	R-896-CFX	-	-	8 x ZYLS30X155	8 x ZYLS30X230	8 x ISO4032-M30

Solid Retaining Ring Flange

Size Inch	Flange	Flat Face/Bonded Seal		Pipe Seal Carrier (PSC)		Nut
		Recommended bolts Tube to Port	Recommended bolts Tube to Tube	Recommended bolts Tube to Port	Recommended bolts Tube to Tube	
8	R-8128-350-TZNX	-	-	8 x ZYLS36X180	8 x ZYLS36X260	8 x ISO4032-M36
8	R-8128219.1-350-TZNX	-	-	8 x ZYLS30X170	8 x ZYLS30X260	8 x ISO4032-M30
10	R-8160273.1-350-TZNX	-	-	12 x ZYLS36X200	12 x ZYLS36X320	12 x ISO4032-M36
12*	R-8192323.9-250-TZNX	16 x ZYLS42X210	16 x ZYLS42X330	-	-	16 x ISO4032-M42

*For 12" sealgroove in tube end face integrated (no bonded seal/seal carrier)

Bolt length for 12" calculated by using Nordlock washer.

Bolts and nuts are not included in complete part numbers.

Latest information about nuts and bolts see www.parker.com/hpce -> Resources -> Installation Guides & Materials

Please add the suffixes according to the bolt quality

	Steel		Stainless Steel
Grade	8.8 zinc plated (VZX)	10.9 zinc flaked (TNFLX)	A4-80X
Bolt	ZYLS16X60VZX	ZYLS16X60109ZNFLX	ZYLS16X60A4-80X
Nut	ISO4032-M12-8VZX	ISO4032-M12-10ZNFLX	ISO4032-M12-80X

Bolt grade 10.9 recommended.
Bolt grade 8.8 can affect the pressure capability.



KH - Ball valve drilled and tapped for ISO 6164 flanges

ISO 6164

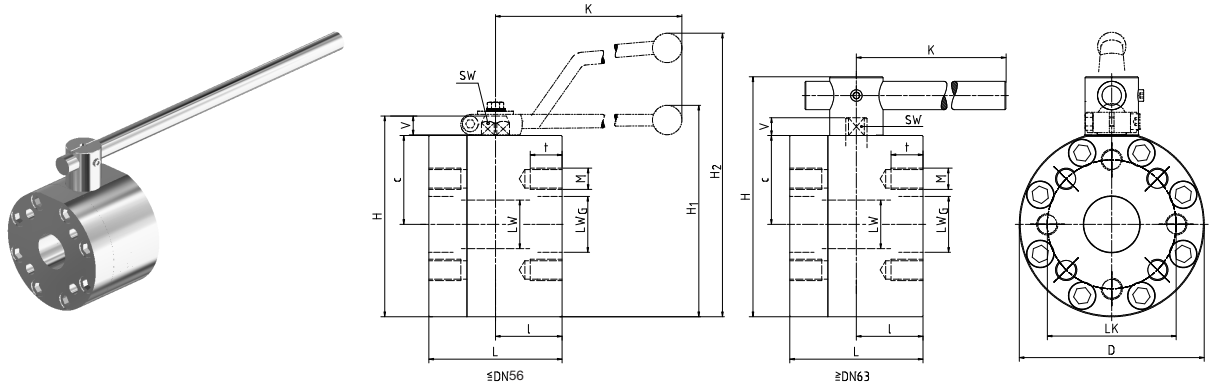

Material Steel

Size Inch	Order Code	DN	LW	LWG	L	I	D	H	c	V	K	SW	LK	M	t	H2	Material Code	Lever	Weight kg	W.P. bar
2	KH432-48CF	50	48	43	123	58	198	210	94	17	306	17	98	4x M16	25.5	283	212A	St	24.90	400
2 1/2	KH440-48CF	56	48	53	123	58	198	210	94	17	306	17	118	4x M20	31.0	283	212A	St	26.60	400
3	KH448-63CF	65	65	63	150	75	208	270	100	20	600	16	145	4x M24	36.0	-	282A	St	36.00	350
4	KH464-76CF	80	76	76	170	78	258	315	115	26	600	19	175	4x M30	35.0	-	282A	St	63.00	400
4	KH464-88CF	90	100	86	170	85	260	327	122	26	900	24	175	4x M30	31.0	-	282A	St	61.00	350
4 1/2	KH872-100CF	100	100	100	170	85	260	327	122	26	900	24	175	8x M20	33.0	-	282A	St	70.00	350
5	KH880-118CF	125	118	118	210	105	300	380	140	32	900	36	205	8x M24	34.0	-	282A	St	99.00	350
6	KH896-150CF	150	150	150	285	130	390	475	190	32	900	36	245	8x M30	46.0	-	282A	St	225.00	350
8	KH8128-200CF	200	192	200	378	150	456	598	223	61	940	46	315	8x M36	55.0	-	242A	St	395.00	350

Other sizes on request.

Please change suffixes according to material/surface required

Order code suffixes		
Material	Suffix surface and material	Example
Steel, zinc plated, Cr(VI)-free	CF	KH432-48CF

	Material		
	212A	282A	242A
Body	Steel	Steel	Steel
Ball	Steel	Steel	Stainless Steel
Stem	Steel	Stainless Steel	Stainless Steel
Ball seats	POM	POM	POM
O-Ring	NBR	NBR	NBR
Tmin / T max	-10°C / 100°C	-10°C / 100°C	-10°C / 100°C

KH – Ball valve drilled and tapped for ISO 6164 flanges

ISO 6164

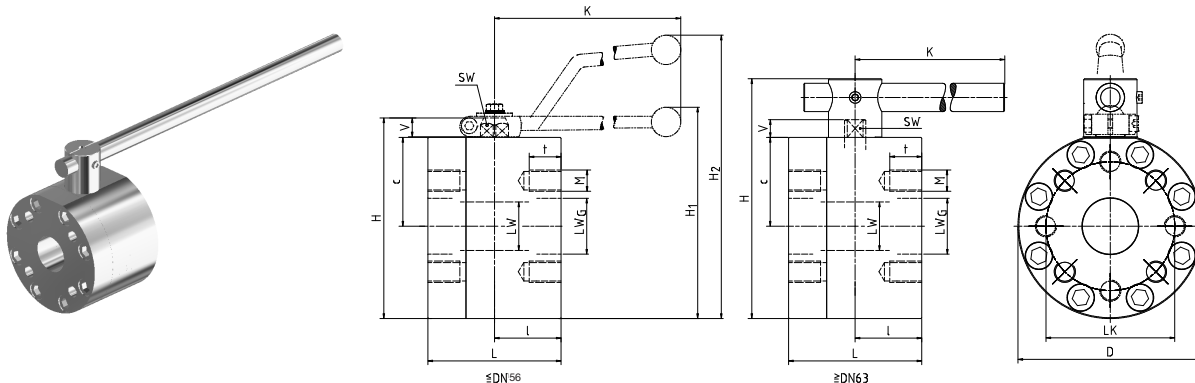

Material Stainless Steel

Size Inch	Order Code	DN	LW	LWG	L	I	D	H	c	V	K	SW	LK	M	t	H1	Lever	Weight kg	W.P. bar
2	KH432-48SS	50	48	43	123	58	198	210	94	17	320	17	98	4x M16	25.5	219	Al	24.90	400
2 1/2	KH440-48SS	56	48	53	123	58	198	210	94	17	320	17	118	4x M20	31.0	219	Al	26.60	400
3	KH448-63SS	65	65	63	150	75	208	270	100	20	600	16	145	4x M24	36.0	-	St	36.00	350
4	KH464-76SS	80	76	76	170	78	258	315	115	26	600	19	175	4x M30	35.0	-	St	63.00	400
4	KH464-88SS	90	100	86	170	85	260	327	122	26	900	24	175	4x M30	31.0	-	St	61.00	350
4 1/2	KH872-100SS	100	100	100	170	85	260	327	122	26	900	24	175	8x M20	33.0	-	St	70.00	350
5	KH880-118SS	125	118	118	210	105	300	380	140	32	900	36	205	8x M24	34.0	-	St	99.00	350
6	KH896-132SS*	150	150	132	285	130	390	475	190	32	900	36	245	8x M30	46.0	-	St	225.00	350
6	KH896-150SS	150	150	150	285	130	390	475	190	32	900	36	245	8x M30	46.0	-	St	225.00	350
8	KH8128-200SS*	200	192	200	378	150	456	598	223	61	940	46	315	8x M36	55.0	-	St	395.00	350

Other sizes on request.

Please change suffixes according to material/surface required

Order code suffixes		
Material	Suffix surface and material	Example
Stainless steel	SS	KH432-48SS

	Material 442A
Body	Stainless Steel
Ball	Stainless Steel
Stem	Stainless Steel
Ball seats	POM
O-Ring	NBR
Tmin / T max	-30°C / 100°C

*For these ball valves Tmin / Tmax = -10°C / 100°C



KH-R - Ball valve with ISO 6164 flanges

ISO 6164

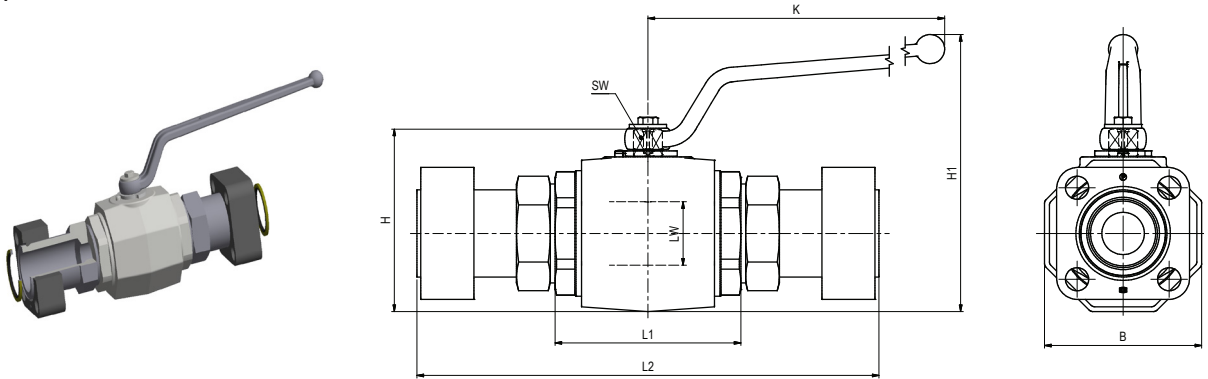

Material Steel

Size Inch	Complete part Order code	Valve body Order code	LW	L1	L2	B	H	SW	K	H1	Weight (Steel) kg/1 kit	W.P. bar
2	KH-R-432-48CF	KH-R-32-48CF	48	140	348.0	118	138	17	306	210	15.2	400

Other sizes on request.

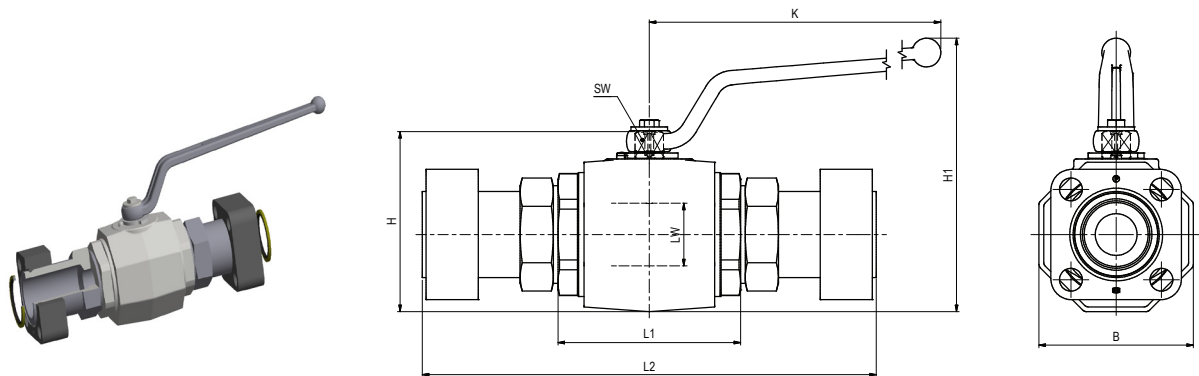

Material Stainless Steel

Size Inch	Complete part Order code	Valve body Order code	LW	L1	L2	B	H	SW	K	H1	Weight (Steel) kg/1 kit	W.P. bar
2	KH-R-432-48SS	KH-R-32-48SS	48	140	348.0	132	145	17	228	219	17.3	400

Other sizes on request.

Please change suffixes according to material/surface required

Order code suffixes		
Material	Suffix surface and material	Example
Steel, zinc plated, Cr(VI)-free	CF	KH-R-432-48CF
Stainless steel	SS	KH-R-432-48SS

	Material 112A	Material 442A
Body	Steel	Stainless Steel
Ball	Steel	Stainless Steel
Stem	Steel	Stainless Steel
Ball seats	POM	POM
O-Ring	NBR	NBR
Tmin / T max	-20°C / 100 °C	-30°C / 100°C

RHD-R - Non return valves

ISO 6164

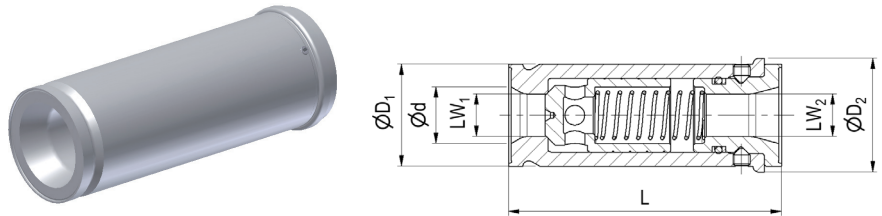

Size Inch	Complete part Order code	Valve body Order code	L	D1	D2	d	LW1	LW2	Weight body (Steel) kg/1 piece	W.P. bar
2	RHD-R-432-0.5BCF	RHD-R-32-0.5BCF	180.1	66	70.5	49	40	36.4	2.54	420

Opening pressure 0.5 bar.
 Other pressure rates on request.
 Complete Part = body + flanges + retaining rings + bonded seals.

Please change suffixes according to material/surface required

Order code suffixes		
Material	Suffix surface and material	Example
Steel, zinc plated, Cr(VI)-free	CF	RHD-R-432-0.5BCF
Stainless steel	SS	RHD-R-432-0.5BSS

	Materials
Body	Steel / Stainless steel
Piston	Steel
O-Ring	NBR
Tmin / T max	-10°C / 100 °C





Pipes and tubes



For your safety!

Under certain circumstances, tubes, fittings and flanges can be subjected to extreme loadings such as vibration and uncontrolled pressure peaks.

Only by using genuine Parker components and following Parker assembly instructions you can be assured of the reliability and safety of the products and their conformity to the applicable standards.

Failure to follow this rule can adversely affect the functional safety and reliability of products, cause personal injury, property damage, and result in loss of your guarantee rights.

Subject to alteration

© Copyright 2023, Parker Hannifin Corporation. All Rights Reserved.

	Page
Introduction	176
Technical properties, calculation rules and standards	178

Tubes: Dimensions and pressure rates

EO-Tubes for fitting systems

Overview EO-fitting systems.....	184
Overview EO-Steel tubes for fitting systems.....	185
Overview EO-Stainless steel tubes for fitting systems.....	187

EO-Steel tubes

seamless, metric, material E235+N / St.37.4 (1.0308).....	189
seamless, metric, material E355+N / St.52.4 (1.0580).....	191

EO-Stainless steel tubes

seamless, metric, material 316Ti (1.4571).....	192
seamless, metric, material 316L (1.4404).....	193
seamless, inch, material 316L (1.4404).....	194

EO-Tubes for flange systems

Overview EO-flange systems.....	196
Overview EO-Steel tubes for flange systems.....	197
Overview EO-Stainless steel tubes for flange systems.....	198

EO-Steel tubes

seamless, metric, material E235+N / St.37.4 (1.0308)	
• for marine- and offshore-applications.....	199
• for industrial- and mobile-applications.....	200
seamless, metric, material E355+N / St.52.4 (1.0580)	
• for marine- and offshore-applications.....	201
• for industrial- and mobile-applications.....	202

EO-Stainless steel tubes

seamless, metric, material 316Ti (1.4571)	
• for marine-and offshore-applications.....	203
• for industrial- and mobile-applications.....	204
seamless, metric, material 316L (1.4404)	
• for marine- and offshore-applications.....	205
• for industrial- und mobile-applications.....	206
seamless, scheduled sizes, material 316L (1.4404)	
• for marine-and offshore-applications.....	207

Conversion tables.....	208
------------------------	-----

Tubes for fluid, hydraulic and pneumatic applications

The world of tubes

Your choice for high pressure.

The tube programme from Parker Hannifin gives all possibilities for usage in hydraulic applications. Tubes for fitting- and flange-systems, tubes for mobile and stationary systems. Different dimensions, carbon- and stainless-steel tubes as well as different surfaces are available.

Approved quality.

Parker tubes are designed for the special requirements in several markets. Continuous tests in laboratories and on the benches ensure the high quality level of the material. Certifications from independent institutes such as ABS, LR, BV or DNV confirm the adherence to high standards. This opens into reliability and longevity of the hydraulic application.

Worldwide connections.

The Parker Hannifin tube-warehouse with its worldwide network provides a close and prompt supply of high precision tubes; thus, international customers can also rely on us. Efficient, reliable, environmentally friendly and on-time deliveries are available in almost every country in the world.

All around tubes.

This brochure provides all relevant information regarding hydraulic lines in a structured and clear way. Which parameters are important, what kind of tubes and dimensions fit the construction and specifications, and which materials are in use in special applications. With Parker order codes you can start right away...

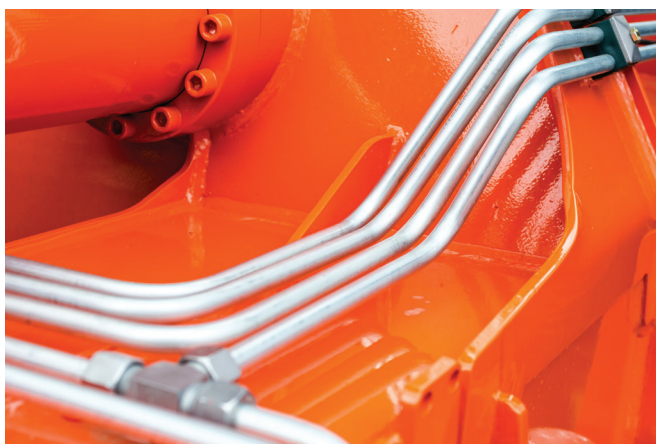

Certificates

Parker is certified acc. ISO 9001 (Quality management), ISO 14001 (Environment management) and ISO/TS 16949 (Quality management).

On request our tubes & pipes have the relevant certificates for your markets. Please ask for details.



Complete Piping Solutions and System Supplier

Added Value maximizes your performance

CPS – Complete Piping Solutions.

Just tubes! But it gets even better. Many customers like to have the complete Parker programme, and that's what we deliver worldwide based on our "Complete Piping Solutions"-concept. Technical support, reengineering, pre-fabrication, delivery and installation. These five steps give an effective and environmentally friendly solution from one source

Our integrated knowledge, quality products, contemporary production methods and installation-experience guarantee perfect complete solutions for hydraulic systems. Integration in existing systems is also available. We help our customers right from their project start to highest productivity and timeliness.

Advantages as a system supplier.

Parker Hannifin is the world's leading diversified manufacturer of motion and control technology. The company offers a product portfolio that is exemplary in the breadth and depth, and in constantly keeping quality. Through an international distribution network, the components are delivered quickly.

System solutions are tailored to the customer's situation. Whether DIN or SAE and available anywhere in the world. It will match everything together with a system, and the global design production is nothing in the way to the last detail. Efficient, sustainable and progressive.

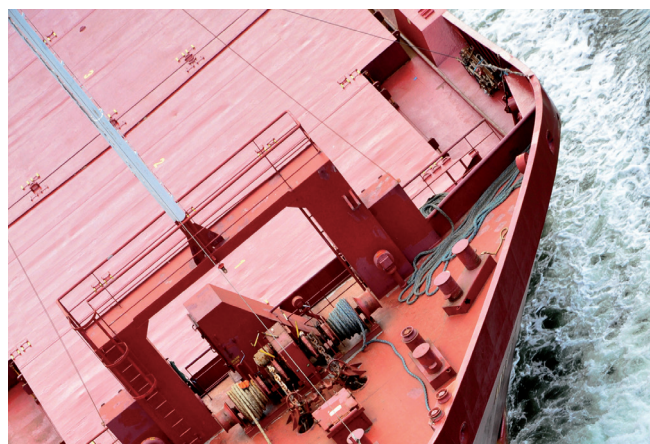

ENGINEERING YOUR SUCCESS.

Tube and pipe specification

Recommended carbon steel tubes and pipes

Parker recommends the use of cold drawn seamless and regular annealed (abbreviation +N) hydraulic tubes and pipes acc.: DIN-EN 10305 (old DIN 2391) and ISO 3304. For the assembly of steel fittings, steel tubes made of material E235 (ST37.4 +N) and E355 (ST52.4 +N) are recommended.

- + precision dimension/shape
- + clean inside
- + high pressure capability
- + excellent scaling surface after roll flaring

Recommended stainless steel tubes and pipes

Parker recommends the use of seamless cold drawn stainless steel tubes and pipes acc. to: DIN EN 10216-5, ASTM A269/A213, ASTM A312.

EO precision stainless steel tube meets and exceeds these standards. The tolerances of the pipe outer diameter and wall thickness are even closer to ensure a safe interplay with our fitting systems.

For the assembly of stainless steel tube fittings, EO precision stainless steel tubes made of material 316 Ti and 316L are recommended.

- + precision dimension/shape
- + excellent scaling surface after roll flaring
- + high pressure capability

Welded tubes and pipes

Tubes and pipes acc. to below specification but welded and cold redrawn instead of seamless drawn are usually suitable. Pressure capability might be reduced due to the welding seam zone. Welding seam quality might effect roll flaring surface results.

Hot rolled pipes

Hot rolled pipes are not recommended for the following reasons:
Hot rolled pipes do not have precision dimensions and may slip in machine dies.
They have scales inside and outside. The inside scales effect the cleanliness level of the fluid and reduces fatigue levels. Used in roll flaring process the scales will contaminate the flaring tools (high cleaning effort) and cause poor flare surface quality.

The required maximum working pressure is calculated either acc. to DIN or DNV.

Material specifications & values

E235+N / St.37.4 (1.0308) acc. to DIN EN 10305-4

Tensile strength	min. 340 N/mm ²
Yield strength	min. 235 N/mm ²
Fatigue strength	225 N/mm ² ¹⁾
Elongation at break	min.. 25%

E355+N / St.52.4 (1.0580) acc. to DIN EN 10305-4

Tensile strength	min. 490 N/mm ²
Yield strength	min. 355 N/mm ²
Fatigue strength	265 N/mm ² ²⁾
Elongation at break	min.. 22 %

316Ti (1.4571) cold drawn (CFA) acc. to DIN EN 10216-5

316L (1.4404) cold drawn (CFA)³⁾ acc. to DIN EN 10216-5

Tensile strength	min. 500 N/mm ²
0.2 % proof stress	min. 210 N/mm ²
1 % proof stress	min. 245 N/mm ²
Fatigue strength	220 N/mm ² ²⁾
Elongation at break	min. 35 %

316L (1.4404) acc. to ASTM A269 / A213 (CFD)

316L (1.4404) acc. to ASTM A312 / A530

Tensile strength	min. 485 N/mm ²
Yield strength	min. 170 N/mm ²
0.2 % proof stress / 1.6	106 N/mm ²
Fatigue strength	220 N/mm ² ²⁾
Elongation at break	min. 35 %

Due to Parker's high quality standards, the DNV-calculation assumes higher values. (see page 182)

¹⁾ DIN 2413, 6.331

²⁾ No standard value, Experience value

³⁾ Strength increase due to cold forming following 1.4571

Tube calculation for industrial and mobile applications acc. to DIN rules

DIN 2413 I, only for static load

Calculation of working pressure of steel tubes for static stress up to 120°C. Corrosion - additional allowances are not considered for the calculation of pressures. Tubes with a diameter of OD/ID > 2 are calculated for static stress in accordance with DIN 2413 III, but with K = yield strength.

$$P = \frac{20 * K * s * c}{S * D}$$

- P = permissible working pressure [bar]
- K = yield strength [N/mm²]
- s = tube wall thickness [mm]
- c = factor for wall thickness allowance
 - = 0.8 for Tube-OD 4-5
 - = 0.85 for Tube-OD 6-8
 - = 0.9 from Tube-OD 10
 - = 0.9 for all stainless steel tubes
- S = Safety factor = 1.5
- D = tube outside diameter [mm]

DIN 2413 III, for dynamic load

Calculation of working pressure of steel tubes for dynamic stress up to 120°C. Corrosion - additional allowances are not considered for the calculation of pressures.

$$P = \frac{20 * K * s * c}{S * (D + s * c)}$$

- P = permissible working pressure [bar]
- K = fatigue strength [N/mm²]
- s = tube wall thickness [mm]
- c = factor for wall thickness allowance
 - = 0.8 for Tube-OD 4-5
 - = 0.85 for Tube-OD 6-8
 - = 0.9 for Tube-OD 10-80
 - = 0.9 for all stainless steel tubes
- S = safety factor = 1.5
- D = tube outside diameter [mm]

Burst pressure calculation

Calculation of static burst pressure for seamless tubes acc. to Faupel-von-Mises.

$$BP = R_{p0.2} * 10 \frac{2}{\sqrt{3}} \ln \frac{D}{d} * (2 - \frac{R_{p0.2}}{R_m})$$

- BP = Min. static burst pressure [bar]
- R = tensile strength [N/mm²]
- R_{p0.2} = 0.2% proof stress, yield strength [N/mm²]
- D = Tube outside diameter [mm]
- d = Tube inside diameter [mm]

Tube calculation for marine and offshore acc. to DNV rules

Calculation of working pressure of steel and stainless steel tubes for ship building acc. to DNV Part 4, Chapter 6, Section 6.

$$P = \frac{20 * \sigma_t * e * t_0}{D - t_0}$$

- P = permissible working pressure [bar]
- BP = approximate burst pressure [bar]
- σ_t = permissible stress [N/mm²]
calculated from the lower value off:

t₀ = tube wall thickness without allowances [mm]

- t_n = tube wall thickness nominal [mm]
- a = factor for wall thickness allowance
 - = 0.8 for Tube-OD 4-5, 0.85 for Tube-OD 6-8, 0.9 for Tube-OD >=10
 - = 0.875 for Schedule Pipes
 - = 0.9 for all stainless steel tubes
- b = bending allowance

- c = corrosion tolerance, c = 0.3 mm for hydraulic steel tube, c = 0 mm for SS tubes
- e = strength ratio: for seamless tubes e = 1
- D = tube outside diameter [mm]
- R_m = min. tensile strength [N/mm²]
- K = min. yield strength or min 0.2% proof stress [N/mm²]

Calculation of burst pressure:

$$BP = \frac{20 * R_m * t_n * a}{D - t_n * a}$$

- | | |
|---|---|
| stainless steel: | carbon steel: |
| σ _t = $\frac{R_m}{2.7}$ or $\frac{K}{1.6}$ | σ _t = $\frac{R_m}{2.7}$ or $\frac{K}{1.8}$ |

$$t_0 = t_n * a - c - b$$

$$b = \frac{1}{2.5} * \frac{D}{R} * t_0$$



$$b = 0.1333 * t_0 \text{ (at } R/D=3) \rightarrow t_0 = \frac{t_n * a - c}{1.1333}$$

Pressure reductions and temperatures

Required pressure reductions (depending on the material) with reference to the catalogue pressures for higher temperatures. Both metal fitting material and elastomeric sealing compound have to be selected according to the temperature range of the system.

DNV may require different pressure reduction based on application

Material	Pressure reduction of permissible operating temperatures TB in °C														
	-60	-50	-40	-35	-25	+20	+50	+100	+120	+150	+175	+200	+250	+300	+400
Steel fittings						0%				11%	19%	28%			
Steel flange-systems				10%			0%			11%	19%				
Steel, tubes						0%					19%		27%		
Stainless steel fittings					0%						19%		27%		
Stainless steel flange-systems				0%			5%	15%	23%		29%	33%	37%	42%	
Stainless steel, tubes				0%			5,5%	11,5%		21,5%			29%	34%	
Sealing material NBR (e.g. Perbunan)															
Sealing material FKM															
Sealing material Polyurethan (P5008)															

	Permissible
	Ambient temperature of hydraulic and pneumatic applications
	Temperature not permissible

Calculation example:
 Temperature = 200°C
 Material = Stainless steel
 Pressure reduction = 29%
 Pressure reduction tubes = 21.5%
 PN tube 16x2.5/71. DIN2413 III = 362 bar

Formula:

$$PN_{200^{\circ}\text{C}} = \frac{400 \text{ bar}}{100\%} \times (100\% - 29\%) = 284 \text{ bar}$$

$$PN_{\text{tube } 200^{\circ}\text{C}} = \frac{362 \text{ bar}}{100\%} \times (100\% - 21.5\%) = 284 \text{ bar}$$

Flow diameter of tube lines

Determining tube sizes for hydraulic systems

Proper tube material, type and size for a given application and type of fitting are critical for efficient and trouble-free operation of the fluid system. Selection of proper tubing involves choosing the right tube material, and determining the optimum tube size (O.D. and wall thickness).

Proper sizing of the tube for various parts of a hydraulic system results in an optimum combination of efficient and cost effective performance.

A tube that is too small causes high fluid velocity, which has many detrimental effects. In pressure lines, it causes high friction losses and turbulence, both resulting in high pressure drops and heat generation. High heat accelerates wear in moving parts and rapid aging of seals and hoses, all resulting in reduced component life. High heat generation also means wasted energy, and hence, low efficiency. Too large tubes increase system cost. Thus, optimum tube sizing is very critical. The following is a simple procedure for sizing tubes.

Determine required flow diameter

Use table to determine recommended flow diameter for the required flow rate and type of line.

The table is based on the following recommended flow rates that are common in the shipbuilding and offshore engineering.

Pressure lines	- 3	→7.2	$\left[\frac{\text{m}}{\text{s}} \right]$
Return lines	- 2	→4.5	$\left[\frac{\text{m}}{\text{s}} \right]$
Suction lines	- 1	→1.8	$\left[\frac{\text{m}}{\text{s}} \right]$

Avoid flow rates > 8 m/s!

The resulting forces are high and can destroy the tube lines.

If you desire to use different velocities than the above, use the following formula to determine the required flow diameter.

$$\text{Tube - I.D. [mm]} = 4,61 \times \sqrt{\frac{\text{Flow} \left[\frac{\text{ltr.}}{\text{min}} \right]}{\text{Velocity} \left[\frac{\text{m}}{\text{s}} \right]}}$$

Determine required wall thickness

Use tube/pressure calculation tables shown in the tube chapter to determine recommended wall thickness for the required working pressure and flow diameter of the line.

Therefore choose a working pressure which is equal or higher than the required working pressure.



Flow characteristics

Hydraulic systems are in most cases only rated with a flow velocity defined on the basis of experience. The pressure losses in lines are not taken into account, or measured later on when testing the system. As the pressure losses increase proportionally greater than the flow resistance, it is important to achieve the best rating of the system, so that they are already taken into account when planning the tube connections. Calculation is not as difficult as it is often thought, and this chapter is intended to provide a guideline. Besides, it provides information on how excessive pressure losses can be avoided, because pressure losses result in losses in performance and excessive heat. Noise occurs and possibly cavitation in suction lines.

Medium

All indication given with regard to flow restrictions and to flow properties refer exclusively to liquids. For gaseous media, the variable density of the gas must additionally be taken into account.

Units

c = Flow velocity $\left[\frac{\text{m}}{\text{s}}\right]$

d = Pipe inside diameter [m]

L = Pipe length [m]

ρ = Pressure [Pa], 1 bar = 100000 Pa

\dot{V} = Flow rate $\left[\frac{\text{m}^3}{\text{s}}\right]$, $1 \frac{\text{m}^3}{\text{s}} = 60000 \frac{\text{l}}{\text{min}}$

λ = Pipe friction factor

$\nu(T)$ = Kinematic viscosity of the medium depending on temperature $\left[\frac{\text{m}^2}{\text{s}}\right]$

$\rho(T)$ = Density of the medium depending on temperature $\left[\frac{\text{kg}}{\text{m}^3}\right]$

ζ = Individual pressure loss coefficient

Only base units have been used. This has the advantage that the formula do not contain correction factors and there is no danger of confusion, e.g. that values are used with the wrong unit. In case values are given in other units - the flow rate is e.g. often given in l/min - it is advisable to convert them into the base units before starting calculation.

Pressure losses in pipe lines

To calculate pressure losses in pipe lines, it must first be determined whether there is a laminar or a turbulent flow. Laminar flow is homogenous and without turbulence. In case of turbulent flow, the losses increase much more quickly.

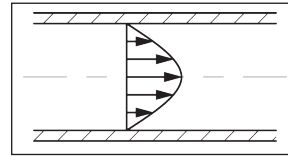

Flow profile with laminar flow

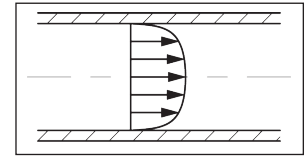

Flow profile with turbulent flow

The kind of flow is defined by the Reynolds' number. With a Reynolds' number of more than 2320, the flow changes to turbulent. The Reynolds' number is calculated according to the formula:

$$Re = \frac{c \cdot d}{\nu(T)}$$

The Reynolds' number is a non-dimensional number. The critical fluid velocity at which the flow regime can change, is thus calculated from:

$$c_{cr} = 2320 \cdot \frac{\nu(T)}{d} \left[\frac{\text{m}}{\text{s}}\right]$$

With a given flow rate, the fluid velocity can be calculated according to the formula:

$$c = \frac{\dot{V} \cdot 4}{d^2 \cdot \pi} \left[\frac{\text{m}}{\text{s}}\right]$$

Subsequently, the pipe friction factor λ can be calculated. The pipe friction factor λ is a function of the Reynolds' number and also depends on the roughness of the pipe. As hydraulically smooth pipes can generally be assumed in hydraulic applications, the pipe friction factor λ is calculated according to the following formula:

$$\text{laminar flow, (Re < 2320): } \lambda = \frac{64}{Re}$$

$$\text{turbulent flow, (Re > 2320): } \lambda = \frac{0.3164}{\sqrt[4]{Re}}$$

Finally, if all factors are known, the pressure loss in a certain pipe line can be calculated according to the formula:

$$\Delta p = \lambda \cdot \frac{L}{d} \cdot \frac{\rho(T) \cdot c^2}{2} \text{ [Pa]}$$

Calculation of individual losses

A hydraulic system does not only incorporate pipes, but also valves, fittings, pipe bends etc. that cause flow losses. These individual losses are often much higher than the pipe losses and are calculated according to the following formula:

$$\Delta p = \zeta \cdot \rho(T) \cdot \frac{c^2}{2} \text{ [Pa]}$$

Material specifications & values for DNV-calculation

Due to Parker's high quality standards, the DNV-calculation assumes higher values for tensile strength and yield strength. These values are experience values. Nominal pressure calculation based on these mechanical properties requires a certification in accordance with 3.1 - EN 10204, which confirms the mechanical properties.

E235+N / St.37.4 (1.0308) acc. to DIN EN 10305-4

Tensile strength	390 N/mm ²
Yield strength	min 235 N/mm ²
Proof stress (Yield strength / 1.8)	130.5 N/mm ²

E355+N / St.52.4 (1.0580) acc. to DIN EN 10305-4

Tensile strength	533 N/mm ²
Yield strength	min 355 N/mm ²
Proof stress (Yield strength / 1.8)	197 N/mm ²

316Ti (1.4571) cold drawn (CFA) acc. to DIN EN 10216-5

316L (1.4404) cold drawn (CFA)¹⁾ acc. to DIN EN 10216-5

316L (1.4404) acc. to ASTM A269 / A213 (CFD)

Tensile strength	530 N/mm ²
Yield strength	min 276 N/mm ²
Proof stress (0,2 % Yield strength / 1.6)	172.5 N/mm ²

316L (1.4404) acc. to ASTM A312 / A530

Tensile strength	515 N/mm ²
Yield strength	min 234 N/mm ²
Proof stress (0,2 % Yield strength / 1,6)	146 N/mm ²

¹⁾ Strength increase due to cold forming following 1.4571

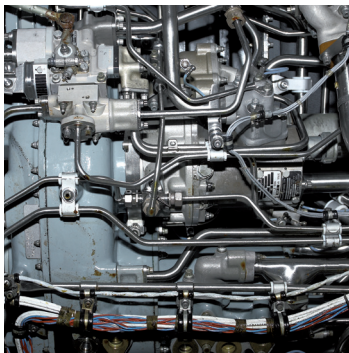

E0-Tubes for fitting systems

Industrial- and Mobile-Applications

Overview EO-Fitting systems

EO-PSR/DPR

Fitting system with progressive stop ring



The advantages

- Special design of the PSR ring with 2 cutting edges for safe, fast and easy assembly
- Special design of the PSR-ring with noticeable end point of assembly by stop contour
- Spring effect compensates subsidences of tube bite and threads - no retightening necessary

As the inventor of the cutting ring (patent of 1934), Parker is looking back on a long history of this milliontimes proven system.

EO-2®

Fitting system with elastomeric seal



The advantages

- Permanently reliable function due to the leak-free elastomeric seal
- Optimized installation space - Prevention of gap extrusion / abrasion
- Protection of over-/underassembly, due to the "Hit-home-feel"
- Clear assembly result by visual pre-assembly inspection

The common feature of all EO-2 fittings is elastomeric seals on all joints. These are also available in FKM for applications with higher temperatures or aggressive media.

EO2-FORM

High pressure formed tube fitting



The advantages

- Absolutely tear-out proof and thus very reliable function
- Significant time and cost savings compared to welding
- Maximum system performance with minimum component, assembly and storage costs

EO2-FORM is based on the EO-2 product family and is therefore an optimal system solution for all hydraulic applications.

O-Lok®

Tube fitting with O-ring face seal



The advantages

- Reliable function and leak-free operation, due to the specially protected O-ring seal
- Higher lifetime and improved corrosion resistant surface
- Easy assembly due to reduced assembly-torques

O-Lok® fittings consist of a nut, a body, an O-ring and a sleeve. The tube is flanged to 90° using the Parflange® system.

Triple-Lok®

Versatile 37°-flare fitting



The advantages

- Wide range of application due to increased nominal pressures
- Sealing surface is protected separately during transport
- More constructive possibilities through the most comprehensive standard programme.

Triple-Lok® fittings convince due to the simple, reliable design, compact design, easy assembly and worldwide availability.

Overview EO steel tubes for fitting systems

Material E235+N / St.37.4 (1.0308)		Material E355+N / St.52.4 (1.0580)		Fitting systems			
				DPR PSR EO-2	EO2 FORM	O-Lok®	Triple- Lok®
Surface Phosphated and oiled	Surface Cr(VI)-free	Surface Phosphated and oiled	Surface Cr(VI)-free				
Order code		Order code					
R04X0.5	R04X0.5CF			X	-	-	-
	R04X0.75CF			X	-	-	-
R04X1	R04X1CF			X	-	-	-
	R05X1CF			X	-	-	-
	R06X0.75CF			X	-	-	-
R06X1	R06X1CF			X	X	X	X
R06X1.5	R06X1.5CF			X	X	X	X
	R06X2CF			X	X	-	-
R06X2.25	R06X2.25CF			X	-	-	-
R08X1	R08X1CF			X	X	X	X
R08X1.5	R08X1.5CF			X	X	X	X
R08X2	R08X2CF			X	X	X	-
	R08X2.5CF			X	X	-	-
R10X1	R10X1CF			X	X	X	X
R10X1.5	R10X1.5CF			X	X	X	X
R10X2	R10X2CF		R10X2ST52CF	X	X	X	-
R10X2.5	R10X2.5CF			X	-	-	-
	R10X3CF			X	X	-	-
R12X1	R12X1CF			X	X	X	X
R12X1.5	R12X1.5CF		R12X1.5ST52CF	X	X	X	X
R12X2	R12X2CF		R12X2ST52CF	X	X	X	X
	R12X2.5CF			X	X	-	-
	R12X3CF			X	X	-	-
	R12X3.5CF			X	-	-	-
	R14X1.5CF			X	-	-	-
R14X2	R14X2CF			X	-	-	-
R14X2.5	R14X2.5CF			X	-	-	-
	R14X3CF			X	-	-	-
R15X1	R15X1CF			X	X	X	X
R15X1.5	R15X1.5CF		R15X1.5ST52CF	X	X	X	X
R15X2	R15X2CF		R15X2ST52CF	X	X	X	X
R16X1.5	R16X1.5CF		R16X1.5ST52CF	X	-	X	X
R16X2	R16X2CF	R16X2ST52	R16X2ST52CF	X	X	X	X
R16X2.5	R16X2.5CF		R16X2.5ST52CF	X	X	X	X
R16X3	R16X3CF			X	X	X	-
R18X1	R18X1CF			X	-	-	-
R18X1.5	R18X1.5CF		R18X1.5ST52CF	X	X	X	X
R18X2	R18X2CF		R18X2ST52CF	X	X	X	X
R18X2.5	R18X2.5CF			X	-	-	X
	R18X3CF			X	-	-	X
	R20X1.5CF			X	-	-	-
R20X2	R20X2CF		R20X2ST52CF	X	X	X	X
R20X2.5	R20X2.5CF		R20X2.5ST52CF	X	X	X	X
R20X3	R20X3CF		R20X3ST52CF	X	X	X	X
	R20X3.5CF			X	X	-	-
	R20X4CF			X	-	-	-
R22X1.5	R22X1.5CF		R22X1.5ST52CF	X	X	X	X
R22X2	R22X2CF		R22X2ST52CF	X	X	X	X
R22X2.5	R22X2.5CF			X	X	X	X
	R22X3CF			X	-	-	X
R25X2	R25X2CF			X	X	X	X
R25X2.5	R25X2.5CF		R25X2.5ST52CF	X	X	X	X
R25X3	R25X3CF	R25X3ST52	R25X3ST52CF	X	X	X	X
R25X4	R25X4CF		R25X4ST52CF	X	X	X	-
	R25X4.5CF			X	-	-	-
R28X1.5	R28X1.5CF			X	-	X	X
R28X2	R28X2CF		R28X2ST52CF	X	X	X	X
R28X2.5	R28X2.5CF			X	X	X	X
R28X3	R28X3CF			X	-	X	X

Overview EO steel tubes for fitting systems

Material				Fitting systems			
E235+N / St.37.4 (1.0308)		E355+N / St.52.4 (1.0580)		PSR EO-2	EO2- FORM	O-Lok®	Triple- Lok®
Surface		Surface					
Phosphated and oiled	Cr(VI)-free	Phosphated and oiled	Cr(VI)-free				
Order code		Order code					
	R30X2CF			X	-	X	X
R30X2.5	R30X2.5CF			X	-	X	X
R30X3	R30X3CF	R30X3ST52	R30X3ST52CF	X	X	X	X
R30X4	R30X4CF		R30X4ST52CF	X	X	X	-
R30X5	R30X5CF		R30X5ST52CF	X	X	-	-
R35X2	R35X2CF			X	X	X	X
R35X2.5	R35X2.5CF			X	-	X	X
R35X3	R35X3CF		R35X3ST52CF	X	X	X	X
	R35X4CF			X	-	-	-
	R38X2.5CF			X	-	X	X
R38X3	R38X3CF		R38X3ST52CF	X	X	X	X
R38X4	R38X4CF	R38X4ST52	R38X4ST52CF	X	X	X	X
R38X5	R38X5CF		R38X5ST52CF	X	X	X	-
	R38X6CF		R38X6ST52CF	X	X	-	-
	R38X7CF			X	X	-	-
R42X2	R42X2CF			X	X	-	X
R42X3	R42X3CF		R42X3ST52CF	X	X	-	X
R42X4	R42X4CF		R42X4ST52CF	X	X	-	-
			R42X5ST52CF	X	-	-	-

Other sizes on request!



Overview EO stainless steel tubes for fitting systems

316Ti (1.4571)	Material		Fitting systems			
	316L (1.4404)		DPR EO-2	EO2- FORM	O-Lok®	Triple- Lok®
	bright annealed	Surface pickled				
Order code						
R04X171		R04X1-316BA	(X)	-	-	-
R06X171		R06X1-316BA	X	X	X	X
R06X1.571		R06X1.5-316BA	X	X	X	X
R08X171		R08X1-316BA	X	X	X	X
R08X1.571			X	X	X	X
R10X171		R10X1-316BA	X	X	X	X
R10X1.571		R10X1.5-316BA	X	X	X	X
R10X271		R10X2-316BA	X	X	X	-
R12X171		R12X1-316BA	X	X	X	X
R12X1.571		R12X1.5-316BA	X	X	X	X
R12X271		R12X2-316BA	X	X	X	X
R14X1.571			X	-	-	-
R14X271			X	-	-	-
R14X2.571			X	-	-	-
R15X171			X	X	X	X
R15X1.571		R15X1.5-316BA	X	X	X	X
R15X271			X	X	X	X
R16X1.571			X	-	X	X
R16X271	R16X2-316		X	X	X	X
R16X2.571	R16X2.5-316		X	X	X	X
R16X371			X	X	X	-
R18X1.571	R18X1.5-316		X	X	X	X
R18X271	R18X2-316		X	X	X	X
R20X271	R20X2-316		X	X	X	X
R20X2.571	R20X2.5-316		X	X	X	X
R20X371			X	X	X	X
R22X1.571			X	X	X	X
R22X271	R22X2-316		X	X	X	X
R25X271	R25X2-316		X	X	X	X
R25X2.571	R25X2.5-316		X	X	X	X
R25X371	R25X3-316		X	X	X	X
R28X1.571			X	-	X	X
R28X271	R28X2-316		X	X	X	X
R28X2.571			X	X	X	X
R30X2.571	R30X2.5-316		X	-	X	X
R30X371	R30X3-316		X	X	X	X
R30X471			X	X	X	-
R35X271			X	X	X	X
R35X2.571			X	-	X	X
R35X371	R35X3-316		X	X	X	X
R38X2.571			X	-	X	X
	R38X3-316		-	X	X	X
R38X471	R38X4-316		X	X	X	X
	R38X5-316		X	X	X	-
	R38X6-316		X	X	-	-
R42X271			X	X	-	X
R42X371	R42X3-316		X	X	-	X

(x) DPR available, EO-2 not available

Other sizes on request!

EO-Tubes for fitting systems (Industrial- and Mobile-Applications)

Overview EO stainless steel tubes for fitting systems

Material 316L (1.4404)	Fitting systems			
	DPR EO-2	EO2- FORM	O-Lok®	Triple- Lok®
	Surface bright annealed			
Order code				
R1/8X0.028TP316/I	-	-	on request	on request
R5/16X0.035TP316/L	-	-	on request	on request
R1/4X0.035TP316/L	-	-	on request	on request
R1/4X0.049TP316/L	-	-	on request	on request
R1/4X0.065TP316/L	-	-	on request	on request
R3/8X0.035TP316/L	-	-	on request	on request
R3/8X0.049TP316/L	-	-	on request	on request
R3/8X0.065TP316/L	-	-	on request	on request
R1/2X0.035TP316/L	-	-	on request	on request
R1/2X0.049TP316/L	-	-	on request	on request
R1/2X0.065TP316/L	-	-	on request	on request
R1/2X0.083TP316/L	-	-	on request	on request
R5/8X0.049TP316/L	-	-	on request	on request
R5/8X0.065TP316/L	-	-	on request	on request
R3/4X0.049TP316/L	-	-	on request	on request
R3/4X0.065TP316/L	-	-	on request	on request
R3/4X0.083TP316/L	-	-	on request	on request
R3/4X0.095TP316/L	-	-	on request	on request
R3/4X0.109TP316/L	-	-	on request	on request
R1X0.065TP316/L	-	-	on request	on request
R1X0.083TP316/L	-	-	on request	on request
R1X0.095TP316/L	-	-	on request	on request
R1X0.126TP316/L	-	-	on request	-

Other sizes on request!



Seamless EO steel tubes | Material E235+N / St.37.4 (1.0308)

Acc. to DIN EN 10305-4

- DIN 2413 I: Tubes with a diameter of OD/ID>2 are calculated for static stress in accordance with DIN 2413 III but with K=yield strength.
- Evaluated in Parker Lab and Test Field. () = Burst pressure (B.P.) acc. to Faupel-von-Mises

Material E235+N / St.37.4 (1.0308)		d _a Outer-Ø (mm)	Outer-Ø Tolerance (mm)	s Wall- thickness (mm)	d _i Inner-Ø (mm)	Design pressure		2 Burst pressure bar	Weight kg/m
Surface						1 DIN 2413 I static PN bar	DIN 2413 III dynamic PN bar		
Phosphated and oiled	Cr(VI)- free	Order code							
R04X0.5	R04X0.5CF	04		0.50	3.0	313	273	1160	0.047
	R04X0.75CF	04	±0.08	0.75	2.5	470	391	1820	0.063
R04X1	R04X1CF	04		1.00	2.0	627	500	2700	0.074
	R05X1CF	05	±0.08	1.00	3.0	501	414	2120	0.099
	R06X0.75CF	06		0.75	4.5	333	288	1150	0.103
R06X1	R06X1CF	06		1.00	4.0	444	372	1650	0.123
R06X1.5	R06X1.5CF	06	±0.08	1.50	3.0	666	526	2550	0.166
	R06X2CF	06		2.00	2.0	692	662	>3500	0.197
R06X2.25	R06X2.25CF	06		2.25	1.5	757	725	>3500	0.208
R08X1	R08X1CF	08		1.00	6.0	333	288	1175	0.173
R08X1.5	R08X1.5CF	08	±0.08	1.50	5.0	499	412	1925	0.240
R08X2	R08X2CF	08		2.00	4.0	666	526	2500	0.296
	R08X2.5CF	08		2.50	3.0	658	630	2650	0.339
R10X1	R10X1CF	10		1.00	8.0	282	248	900	0.222
R10X1.5	R10X1.5CF	10		1.50	7.0	423	357	1450	0.314
R10X2	R10X2CF	10	±0.08	2.00	6.0	564	458	2025	0.395
R10X2.5	R10X2.5CF	10		2.50	5.0	705	551	2675	0.462
	R10X3CF	10		3.00	4.0	666	638	>3500	0.518
R12X1	R12X1CF	12		1.00	10.0	235	209	750	0.271
R12X1.5	R12X1.5CF	12		1.50	9.0	353	303	1150	0.388
R12X2	R12X2CF	12	±0.08	2.00	8.0	470	391	1600	0.493
	R12X2.5CF	12		2.50	7.0	588	474	2025	0.586
	R12X3CF	12		3.00	6.0	705	551	2600	0.666
	R12X3.5CF	12		3.50	5.0	651	624	(3109)	0.734
	R14X1.5CF	14		1.50	11.0	302	264	975	0.462
R14X2	R14X2CF	14	±0.08	2.00	10.0	403	342	1325	0.592
R14X2.5	R14X2.5CF	14		2.50	9.0	504	415	1650	0.709
	R14X3CF	14		3.00	8.0	604	485	2200	0.814
R15X1	R15X1CF	15		1.00	13.0	188	170	575	0.345
R15X1.5	R15X1.5CF	15	±0.08	1.50	12.0	282	248	950	0.499
R15X2	R15X2CF	15		2.00	11.0	376	321	1275	0.641
R16X1.5	R16X1.5CF	16		1.50	13.0	264	233	850	0.536
R16X2	R16X2CF	16	±0.08	2.00	12.0	353	303	1175	0.691
R16X2.5	R16X2.5CF	16		2.50	11.0	441	370	1500	0.832
R16X3	R16X3CF	16		3.00	10.0	529	433	1850	0.962
R18X1	R18X1CF	18		1.00	16.0	157	143	450	0.419
R18X1.5	R18X1.5CF	18		1.50	15.0	235	209	700	0.610
R18X2	R18X2CF	18	±0.08	2.00	14.0	313	273	975	0.789
R18X2.5	R18X2.5CF	18		2.50	13.0	392	333	1300	0.956
	R18X3CF	18		3.00	12.0	470	391	1575	1.111

Surface finish:

- Tubes with I.D. 1.5-5 mm: outside and inside oiled.
- Tubes from 6 mm I.D.: outside and inside phosphated and oiled.

• Cr(VI)-free:

These dimensions are externally thick coat passivated (thickness of coat 8-12µm), inside oiled.

EO-Tubes for fitting systems (Industrial- and Mobile-Applications)

Seamless EO steel tubes (continued) | Material E235+N / St.37.4 (1.0308)

Acc. to DIN EN 10305-4

1. DIN 2413 I: Tubes with a diameter of OD/ID>2 are calculated for static stress in accordance with DIN 2413 III but with K=yield strength.
2. Evaluated in Parker Lab and Test Field.

Material E235+N / St.37.4 (1.0308)		d _a Outer-Ø (mm)	Outer-Ø Tolerance (mm)	s Wall- thickness (mm)	d _i Inner-Ø (mm)	Design pressure		2 Burst pressure bar	Weight kg/m
Surface						1 DIN 2413 I static PN bar	DIN 2413 III dynamic PN bar		
Phosphated and oiled	Cr(VI)- free	Order code							
R20X2	R20X1.5CF	20	±0.08	1.50	17.0	212	190	675	0.684
	R20X2CF	20		2.00	16.0	282	248	900	0.888
R20X2.5	R20X2.5CF	20		2.50	15.0	353	303	1100	1.079
R20X3	R20X3CF	20		3.00	14.0	423	357	1400	1.258
	R20X3.5CF	20		3.50	13.0	494	408	1650	1.424
	R20X4CF	20	4.00	12.0	564	458	2000	1.578	
R22X1.5	R22X1.5CF	22	±0.08	1.50	19.0	192	173	550	0.758
R22X2	R22X2CF	22		2.00	18.0	256	227	775	0.986
R22X2.5	R22X2.5CF	22		2.50	17.0	320	278	1025	1.202
	R22X3CF	22		3.00	16.0	385	328	1175	1.406
R25X2	R25X2CF	25	±0.08	2.00	21.0	226	201	725	1.134
R25X2.5	R25X2.5CF	25		2.50	20.0	282	248	850	1.387
R25X3	R25X3CF	25		3.00	19.0	338	292	1025	1.628
R25X4	R25X4CF	25		4.00	17.0	451	378	1500	2.072
	R25X4.5CF	25		4.50	16.0	508	418	1625	2.275
R28X1.5	R28X1.5CF	28	±0.08	1.50	25.0	151	138	425	0.980
R28X2	R28X2CF	28		2.00	24.0	201	181	600	1.282
R28X2.5	R28X2.5CF	28		2.50	23.0	252	223	750	1.572
R28X3	R28X3CF	28		3.00	22.0	302	264	900	1.850
R30X2.5	R30X2CF	30	±0.08	2.00	26.0	188	170	575	1.381
	R30X2.5CF	30		2.50	25.0	235	209	725	1.695
R30X3	R30X3CF	30		3.00	24.0	282	248	850	1.998
R30X4	R30X4CF	30		4.00	22.0	376	321	1175	2.565
R30X5	R30X5CF	30		5.00	20.0	470	391	1600	3.083
R35X2	R35X2CF	35	±0.15	2.00	31.0	161	147	450	1.628
R35X2.5	R35X2.5CF	35		2.50	30.0	201	181	600	2.004
R35X3	R35X3CF	35		3.00	29.0	242	215	700	2.367
	R35X4CF	35		4.00	27.0	322	280	960	3.058
R38X3	R38X2.5CF	38	±0.15	2.50	33.0	186	168	550	2.189
	R38X3CF	38		3.00	32.0	223	199	675	2.589
R38X4	R38X4CF	38		4.00	30.0	297	260	900	3.354
R38X5	R38X5CF	38		5.00	28.0	371	318	1150	4.069
	R38X6CF	38		6.00	26.0	445	373	1425	4.735
	R38X7CF	38		7.00	24.0	519	427	1700	5.352
R42X2	R42X2CF	42	±0.20	2.00	38.0	134	123	375	1.973
R42X3	R42X3CF	42		3.00	36.0	201	181	575	2.885
R42X4	R42X4CF	42		4.00	34.0	269	237	850	3.749

Other sizes on request!



Seamless EO steel tubes | Material E355+N / St.52.4 (1.0580)

Acc. to DIN EN 10305-4

1. DIN 2413 I: Tubes with a diameter of OD/ID>2 are calculated for static stress in accordance with DIN 2413 III but with K=yield strength.
2. Burst pressure (B.P.) acc. to Faupel-von-Mises

Material E355+N / St.52.4 (1.0580)		d _a Outer-Ø (mm)	Outer-Ø Tolerance (mm)	s Wall- thickness (mm)	d _i Inner-Ø (mm)	Design pressure		2 Burst pressure bar	Weight kg/m
Surface						1 DIN 2413 I static PN bar	DIN 2413 III dynamic PN bar		
Phosphated and oiled	Cr(VI)- free								
Order code									
	R10X2ST52CF	10	±0.08	2.00	6.0	852	539	2671	0.395
	R12X1.5ST52CF	12	±0.08	1.50	9.0	533	357	1504	0.388
	R12X2ST52CF	12		2.00	8.0	710	461	2120	0.493
	R15X1.5ST52CF	15	±0.08	1.50	12.0	426	292	1167	0.499
	R15X2ST52CF	15		2.00	11.0	568	379	1622	0.641
R16X2ST52	R16X1.5ST52CF	16	±0.08	1.50	13.0	399	275	1086	0.536
	R16X2ST52CF	16		2.00	12.0	533	357	1504	0.691
	R16X2.5ST52CF	16		2.50	11.0	666	436	1959	0.832
	R18X1.5ST52CF	18	±0.08	1.50	15.0	355	247	953	0.610
	R18X2ST52CF	18		2.00	14.0	473	321	1314	0.789
	R20X2ST52CF	20	±0.08	2.00	16.0	426	292	1167	0.888
	R20X2.5ST52CF	20		2.50	15.0	533	357	1504	1.079
	R20X3ST52CF	20		3.00	14.0	639	420	185	1.258
	R22X1.5ST52CF	22	±0.08	1.50	19.0	290	204	767	0.758
	R22X2ST52CF	22		2.00	18.0	387	267	1049	0.986
R25X3ST52	R25X2.5ST52CF	25	±0.08	2.50	20.0	426	292	1167	1.387
	R25X3ST52CF	25		3.00	19.0	511	344	1435	1.628
	R25X4ST52CF	25		4.00	17.0	682	445	2016	2.072
	R28X2ST52CF	28	±0.08	2.00	24.0	304	213	806	1.282
R30X3ST52	R30X3ST52CF	30	±0.08	3.00	24.0	426	292	1167	1.998
	R30X4ST52CF	30		4.00	22.0	568	379	1622	2.565
	R30X5ST52CF	30		5.00	20.0	710	461	2120	3.083
	R35X3ST52CF	35	±0.15	3.00	29.0	365	253	983	2.367
R38X4ST52	R38X3ST52CF	38	±0.15	3.00	32.0	336	234	899	2.589
	R38X4ST52CF	38		4.00	30.0	448	306	1236	3.354
	R38X5ST52CF	38		5.00	28.0	561	374	1597	4.069
	R38X6ST52CF	38		6.00	26.0	673	440	1984	4.735
	R42X3ST52CF	42	±0.20	3.00	36.0	304	213	806	2.885
	R42X4ST52CF	42		4.00	34.0	406	279	1105	3.748
	R42X5ST52CF	42		5.00	32.0	507	342	1422	4.562

Surface finish:

- Tubes with I.D. 1.5-5 mm: outside and inside oiled.
- Tubes from 6 mm I.D.: outside and inside phosphated and oiled.

• Cr(VI)-free:

These dimensions are externally thick coat passivated (thickness of coat 8-12µm), inside oiled.

Other sizes on request!

EO-Tubes for fitting systems (Industrial- and Mobile-Applications)

Seamless EO stainless steel tubes | Material 316Ti (1.4571)

Acc. to DIN EN 10216-5, DIN EN 10305-1

1. DIN 2413 I: Tubes with a diameter of OD/ID>2 are calculated for static stress in accordance with DIN 2413 III but with K=yield strength.
2. Evaluated in Parker Lab and Test Field. () = Burst pressure (B.P.) acc. to Faupel-von-Mises

Material 316Ti (1.4571)	d _a Outer-Ø (mm)	Outer-Ø Tolerance (mm)	s Wall- thickness (mm)	d _i Inner-Ø (mm)	Design pressure		2 Burst pressure bar	Weight kg/m
					1	DIN 2413 III		
					DIN 2413 I static PN bar	dynamic PN bar		
Order code								
R04X171	04	±0.08	1.0	2.0	735	539	(2961)	0.075
R06X171	06		1.0	4.0	490	383	1850	0.125
R06X1.571	06	±0.08	1.5	3.0	735	539	2900	0.169
R08X171	08		1.0	6.0	368	297	1300	0.175
R08X1.571	08	±0.08	1.5	5.0	551	424	2050	0.244
R10X171	10		1.0	8.0	294	242	950	0.225
R10X1.571	10	±0.08	1.5	7.0	441	349	1750	0.319
R10X271	10		2.0	6.0	588	447	2400	0.401
R12X171	12		1.0	10.0	245	205	850	0.275
R12X1.571	12	±0.08	1.5	9.0	368	297	1400	0.394
R12X271	12		2.0	8.0	490	383	1900	0.501
R14X1.571	14		1.5	11.0	315	258	1200	0.469
R14X271	14	±0.08	2.0	10.0	420	334	1550	0.601
R14X2.571	14		2.5	9.0	525	406	2100	0.720
R15X171	15		1.0	13.0	196	166	675	0.351
R15X1.571	15	±0.08	1.5	12.0	294	242	1100	0.507
R15X271	15		2.0	11.0	392	314	1400	0.651
R16X1.571	16		1.5	13.0	276	228	950	0.545
R16X271	16	±0.08	2.0	12.0	368	297	1300	0.701
R16X2.571	16		2.5	11.0	459	362	1850	0.845
R16X371	16		3.0	10.0	551	424	2400	0.977
R18X1.571	18		1.5	15.0	245	205	800	0.620
R18X271	18	±0.08	2.0	14.0	327	267	1150	0.801
R20X271	20		2.0	16.0	294	242	1050	0.901
R20X2.571	20	±0.08	2.5	15.0	368	297	1400	1.095
R20X371	20		3.0	14.0	441	349	1800	1.277
R22X1.571	22		1.5	19.0	200	170	650	0.770
R22X271	22	±0.08	2.0	18.0	267	222	900	1.002
R25X271	25		2.0	21.0	235	197	763	1.152
R25X2.571	25	±0.08	2.5	20.0	294	242	1050	1.408
R25X371	25		3.0	19.0	353	286	1275	1.653
R28X1.571	28		1.5	25.0	158	135	550	0.995
R28X271	28	±0.08	2.0	24.0	210	177	700	1.302
R28X2.571	28		2.5	23.0	263	218	(840)	1.596
R30X2.571	30		2.5	25.0	245	205	850	1.722
R30X371	30	±0.08	3.0	24.0	294	242	1150	2.028
R30X471	30		4.0	22.0	392	314	1500	2.605
R35X271	35		2.0	31.0	168	143	550	1.653
R35X2.571	35	±0.15	2.5	30.0	210	177	(659)	2.035
R35X371	35		3.0	29.0	252	210	(803)	2.404
R38X2.571	38		2.5	33.0	193	164	628	2.222
R38X471	38	±0.15	4.0	30.0	309	254	1150	3.405
R42X271	42		2.0	38.0	140	121	475	2.003
R42X371	42	±0.20	3.0	36.0	210	177	750	2.930

Other sizes on request!



Seamless EO stainless steel tubes | Material 316L (1.4404)

Acc. to DIN 10216-5, DIN 10305-1 (-316BA); ASTM A269/A213 (-316)

- Due to Parker's high quality standards, the pickled tubes (-316) are calculated according to the values of bright annealed tubes (-316BA). Nominal pressure calculation based on these mechanical properties requires certification in accordance with 3.1 - EN 10204, which confirms the mechanical properties
- DIN 2413 I static pressure (W.P.) capability for straight pipe including manufacturing tolerance.
- Burst pressure (B.P.) acc. to Faupel-von-Mises

Material 316L (1.4404)		Outer-Ø Tolerance (mm)	s Wall- thickness (mm)	di Inner-Ø (mm)	Design pressure		3 Burst pressure bar	Weight kg/m
Surface					2 DIN 2413 I static PN bar	DIN 2413 III dynamic PN bar		
1 pickled	bright annealed							
Order code								
	R04X1-316BA	±0.08	1.0	2.0	735	539	2961	0.075
	R06X1-316BA	±0.08	1.0	4.0	490	383	1732	0.125
	R06X1.5-316BA		1.5	3.0	735	539	2961	0.169
	R08X1-316BA	±0.08	1.0	6.0	368	297	1229	0.175
	R10X1-316BA	±0.08	1.0	8.0	294	242	953	0.225
	R10X1.5-316BA		1.5	7.0	441	349	1524	0.319
	R10X2-316BA		2.0	6.0	588	447	2182	0.401
	R12X1-316BA	±0.08	1.0	10.0	245	205	779	0.275
	R12X1.5-316BA		1.5	9.0	368	297	1229	0.394
	R12X2-316BA		2.0	8.0	490	383	1732	0.501
	R15X1.5-316BA	±0.08	1.5	12.0	294	242	953	0.507
R16X2-316		±0.08	2.0	12.0	368	297	1229	0.701
R16X2.5-316			2.5	11.0	459	362	1601	0.845
R18X1.5-316		±0.08	1.5	15.0	245	205	779	0.620
R18X2-316			2.0	14.0	327	267	1074	0.801
R20X2-316		±0.08	2.0	16.0	294	242	953	0.901
R20X2.5-316			2.5	15.0	368	297	1229	1.096
R22X2-316		±0.08	2.0	18.0	267	222	857	1.002
R25X2-316		±0.08	2.0	21.0	235	197	745	1.152
R25X2.5-316			2.5	20.0	294	242	953	1.409
R25X3-316			3.0	19.0	353	286	1172	1.653
R28X2-316		±0.08	2.0	24.0	210	177	659	1.302
R30X2.5-316		±0.08	2.5	25.0	245	205	779	1.722
R30X3-316			3.0	24.0	294	242	953	2.028
R35X3-316		±0.15	3.0	29.0	252	210	803	2.404
R38X3-316		±0.15	3.0	32.0	232	195	734	2.629
R38X4-316			4.0	30.0	309	254	1010	3.405
R38X5-316			5.0	28.0	387	311	1305	4.132
R38X6-316			6.0	26.0	464	365	1621	4.808
R42X3-316			±0.20	3.0	36.0	210	177	659

Other sizes on request!

EO-Tubes for fitting systems (Industrial- and Mobile-Applications)

Seamless EO stainless steel tubes | Material 316L (1.4404/1.4435)

Acc. to DIN EN 10216-5, DIN EN 10305-1

1. DIN 2413 I: Tubes with a diameter of OD/ID>2 are calculated for static stress in accordance with DIN 2413 III but with K=yield strength.
2. Burst pressure (B.P.) calculation acc. to Faupel-von-Mises

Material 316 L (1.4404)	d _a Outer-Ø (mm)		s Wallthickness		d Inner-Ø (mm)	Design pressure		2 Burst pressure bar	Weight kg/m
						1	DIN 2413 III		
	Surface bright annealed	Inch	mm	Inch		mm	DIN 2413 I static PN bar		
Order code									
R1/8X0.028TP316/L	1/8	3.18	0.028	0.71	1.76	659	492	2538	0.044
R3/16X0.035TP316/L	3/16	4.76	0.035	0.89	2.98	549	422	1996	0.086
R1/4X0.035TP316/L	1/4	6.35	0.035	0.89	4.57	412	328	1403	0.122
R1/4X0.049TP316/L			0.049	1.24	3.87	576	440	2126	0.159
R1/4X0.065TP316/L			0.065	1.65	3.05	619	556	3135	0.194
R3/8X0.035TP316/L	3/8	9.53	0.035	0.89	7.75	274	227	883	0.193
R3/8X0.049TP316/L			0.049	1.24	7.05	384	309	1294	0.257
R3/8X0.065TP316/L			0.065	1.65	6.23	510	396	1818	0.326
R1/2X0.035TP316/L	1/2	12.70	0.035	0.89	10.92	206	174	644	0.263
R1/2X0.049TP316/L			0.049	1.24	10.22	288	238	932	0.356
R1/2X0.065TP316/L			0.065	1.65	9.40	382	307	1286	0.457
R1/2X0.083TP316/L			0.083	2.11	8.48	488	381	1724	0.560
R5/8X0.049TP316/L	5/8	15.88	0.049	1.24	13.40	230	193	729	0.455
R5/8X0.065TP316/L			0.065	1.65	12.58	306	251	996	0.588
R3/4X0.049TP316/L	3/4	19.05	0.049	1.24	16.57	192	163	598	0.553
R3/4X0.065TP316/L			0.065	1.65	15.75	255	212	813	0.719
R3/4X0.083TP316/L			0.083	2.11	14.83	325	266	1069	0.895
R3/4X0.095TP316/L			0.095	2.41	14.23	372	300	1248	1.004
R3/4X0.109TP316/L			0.109	2.77	13.51	427	339	1467	1.129
R1X0.065TP316/L	1	25.40	0.065	1.65	22.10	191	162	595	0.981
R1X0.083TP316/L			0.083	2.11	21.18	244	204	775	1.231
R1X0.095TP316/L			0.095	2.41	20.58	279	231	900	1.387
R1X0.126TP316/L			0.126	3.20	19.00	370	299	1240	1.779

Other sizes on request!





E0-Tubes for flange systems

Marine- and Offshore-Applications

Industrial- and Mobile-Applications

Overview EO flange systems

The Parflange® F37 Programme consists of two flange connection technologies: The 37° Flare Flange Connection and the Retaining Ring Connection.

F37 Flaring system



The advantages

- No welding
- No post-weld cleaning
- No welding stress corrosion possible
- No "hot work" permit required
- Workshop prefabrication
- Easy dismantling and reassembling

In this configuration, the deburred tube end is flared orbitally to 37° by Parflange® technology. An insert, soft sealed by an O-ring, is located into each pipe end. In between a F37 Seal (optionally Bonded Seal or O-ring) is placed. By tightening the flanges together, a soft sealed, high pressure tube connection is made. Available as tube-to-tube connection or tube-to-port connection. The Parflange® F37 flanged connector system is utilising this orbital tube forming technology for tubing assemblies from 16 to 168.3 mm (1/2" to 6" Flanges) outside diameter. It is intended for tube wall thickness up to 9 mm and pressure ratings up to 420 bar. It is available as a high pressure version from 1 1/2" to 10" and as a newly developed SAE 1000 (50-70 bar) version.

F37 Retaining ring system

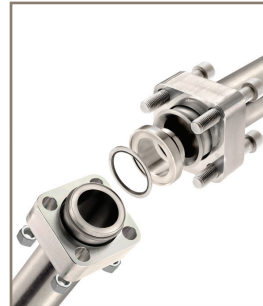

The advantages

- No welding
- No post-weld cleaning
- No welding stress corrosion possible
- No "hot work" permit required
- Workshop prefabrication
- Easy dismantling and reassembling

The retaining ring used in this connection is a stainless steel segmented ring covered by a stainless steel spring. It is assembled in a machined groove on the tube end or adapter. When tightening this system, the flange is pushed against the retaining ring, thus giving a form tight connection. Retaining ring connections complete the Parflange® F37 range with bulkhead, male, female, weld and tube bend connections.

It is available as a high pressure version from 1 1/2" to 10" and as a newly developed SAE 1000 (50-70 bar) version.

HPF - High Performance flange system

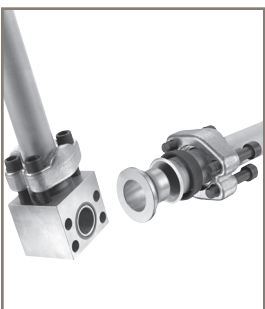

The advantages

- With HPF zinc-plated tubes can be used
- Welding seams must not be descaled and stained
- Tubes assembled with HPF do not require any cleaning
- The flanging process does not cause noxious gases, thus eliminating explosion and fire hazards

Parker's HPF system has been specially designed and developed to meet the requirements of mobile hydraulic and industrial equipment: high performance and high pressure. The HPF system is adjusted to standard tube dimensions used in these industries. Diameters from 25 to 150 mm and wall thicknesses up to 17.5 mm. The system is designed for flange patterns according to ISO 6162-1 (SAE J518, code 61), ISO 6162-2 (SAE J518, code 62) and ISO 6164.

The lockring constitutes the core of the HPF connector. It is specially hardened, phosphated and manufactured with a particular contour. This ring supporting the tube on the outside provides additional tear-off safety for the connection. Depending on the size of the tube the safety function of the lockring is substituted for a specially designed and hardened one-piece flange with an adapted internal contour. An insert is placed into the flared end of the tube. On the port side the sealing is guaranteed selectively by a special profile seal or an O-ring seal, on the tube side by an O-ring seal. The application of these soft-sealing elements both on the port side and the tube side guarantees the gas leak tightness of the HPF connector. As the insert does not have a toothed profile, it can be easily assembled repeatedly.

Overview E0 steel tubes for flange systems

Material E235+N / St.37.4 (1.0308)		Flange system		
Surface		F37 Flare	F37 Retaining ring	HPF
Phosphated and oiled	Cr(VI)-free			
Order code				
R12X1.5	R12X1.5CF	-	X*	-
R16X2	R16X2CF	X	X*	-
R18X2	R18X2CF	X	X*	-
R20X2	R20X2CF	X	-	-
R20X2.5	R20X2.5CF	X	X*	-
R25X2.5	R25X2.5CF	X	X*	-
R25X3	R25X3CF	X	X*	-
R30X3	R30X3CF	X	X*	-
R30X4	R30X4CF	X	X*	-
	R38X2.5CF	X	-	-
R38X3	R38X3CF	X	-	-
R38X4	R38X4CF	X	X*	-
R38X5	R38X5CF	X	X*	-
R38X7		-	X*	-
R42X2	R42X2CF	X	-	-
R42X3	R42X3CF	X	X*	-
R42X4	R42X4CF	X	X*	-
R50X3	R50X3CF	X	X*	-
R50X6		X	X*	-
R60X3	R60X3CF	X	X*	-
R65X8		-	X*	-
R75X3	R75X3CF	X	X*	-
R90X3.5	R90X3.5CF	X	X*	-
R100X4		X	X*	-
R115X4		X	-	-
R140X4.5		X	X*	-
R165X5		X	X*	-
R220X6		X	X*	-
R273X6		X	X*	-

Material E355+N / St.52.4 (1.0580)		Flange system		
Surface		F37 Flare	F37 Retaining ring	HPF
Phosphated and oiled	Cr(VI)-free			
Order code				
	R12X1.5ST52CF	-	X*	-
R16X2ST52	R16X2ST52CF	X	X*	-
	R18X2ST52CF	X	X*	-
	R20X2ST52CF	X	-	-
R20X2.5ST52	R20X2.5ST52CF	X	X*	-
	R25X2.5ST52CF	X	X*	-
R25X3ST52	R25X3ST52CF	X	X*	X
	R25X4ST52CF	-	-	X
R30X3ST52	R30X3ST52CF	X	X*	-
	R30X4ST52CF	X	X*	X
	R30X5ST52CF	-	-	X
	R38X3ST52CF	X	-	-
R38X4ST52	R38X4ST52CF	X	X*	X
	R38X5ST52CF	X	X*	X
	R38X6ST52CF	-	-	X
	R39X7.5ST52CF	-	X	-
	R42X3ST52CF	X	X*	-
	R42X4ST52CF	X	X*	X
	R42X5ST52CF	-	-	X
	R46X8ST52CF	-	X*	-
	R50X3ST52CF	X	X*	X
R50X5ST52	R50X5ST52CF	X	X*	X
	R50X6ST52CF	X	X*	X
	R50X8ST52CF	-	-	X
R56X8.5ST52	R56X8.5ST52CF	-	X	-
	R60X3ST52CF	X	X*	-
	R60X5ST52CF	X	X*	X
R60X6ST52	R60X6ST52CF	X	X*	X
	R60X8ST52CF	-	X*	X
R60X10ST52		-	X*	X
	R65X8ST52CF	-	X*	X
R66X8.5ST52	R66X8.5ST52CF	-	X	X
R73X7ST52	R73X7ST52CF	X	X*	X
R75X5ST52	R75X5ST52CF	X	X*	-
R75X12.5ST52		-	-	X
R80X3ST52		-	-	X
R80X8ST52		-	-	X
R80X10ST52		-	X	X
R88X14ST52		-	-	X
R90X3.5ST52		X	X*	-
R90X5ST52		X	X*	X
R90X9ST52		X	X*	X
R97X12ST52		-	X	X
R101.6X16ST52		-	-	X
R114.3X17.5ST52		-	X	X
R115X15ST52		-	X	X
R120X20ST52		-	-	X
R130X15ST52		-	X	X
R150X15ST52		-	X	X
R190X20ST52		-	X	-
R250X25ST52		-	X	-

X*= Retaining ring weld adapter

Other sizes on request!

Overview EO stainless steel tubes for flange systems

Material 316Ti (1.4571)	Flange system		
	F37 Flare	F37 Retaining ring	HPF
Order code			
R12X1.571	-	X*	-
R16X271	X	X*	-
R18X271	X	X*	-
R20X271	X	-	-
R20X2.571	X	X*	-
R25X2.571	X	X*	-
R25X371	X	X*	-
R30X371	X	X*	-
R30X471	X	X*	-
R38X2.571	X	-	-
R38X471	X	X*	-
R42X371	X	X*	-

Material 316L (1.4404)	Flange system		
	F37 Flare	F37 Retaining ring	HPF
Order code			
R21.34X2.11-316	on request	X*	-
R21.34X2.77-316	on request	X*	-
R21.34X3.73-316	on request	X*	-
R21.34X4.78-316	-	X*	-
R26.67X2.11-316	on request	X*	-
R26.67X2.87-316	on request	X*	-
R26.67X3.91-316	on request	X*	-
R26.67X5.56-316	-	X*	-
R33.40X2.77-316-A999	on request	X*	-
R33.40X3.38-316-A999	on request	X*	-
R33.40X4.55-316-A999	-	X*	-
R33.40X6.35-316-A999	-	X*	-
R42.16X2.77-316-A999	on request	X*	-
R42.16X3.56-316-A999	on request	X*	-
R42.16X4.85-316-A999	on request	X*	-
R42.16X6.35-316-A999	-	X*	-
R48.26X2.77-316-A999	on request	X*	-
R48.26X3.68-316-A999	on request	X*	-
R48.26X5.08-316-A999	on request	X*	-
R48.26X7.14-316-A999	-	X*	-
R60.33X2.77-316-A999	on request	X*	-
R60.33X3.92-316-A999	on request	X*	-
R60.33X5.54-316-A999	on request	X*	-
R60.33X8.74-316-A999	-	X*	-
R73.03X3.05-316-A999	on request	X*	-
R73.03X5.16-316-A999	on request	X*	-
R73.03X7.01-316-A999	on request	X*	-
R73.03X9.52-316-A999	-	X	-
R88.90X3.05-316	X	X*	-
R88.90X5.49-316-A999	on request	X*	-
R88.90X7.62-316-A999	on request	X*	-
R88.90X11.13-316-A999	-	X	-
R114.30X3.05-316-A999	on request	X*	-
R114.30X6.02-316-A999	on request	X*	-
R114.30X8.56-316-A999	-	X*	-
R114.30X13.49-316-A999	-	X	-
R141.30X6.55-316-A999	on request	X*	-
R141.30X9.53-316-A999	-	X*	-
R141.30X15.88-316-A999	-	X	-
R168.26X3.40-316	on request	X*	-
R168.28X7.11-316-A999	-	X*	-
R168.28X18.26-316-A999	-	X	-
R219.08X8.18-316	-	X*	-
R219.08X23.01-316-A999	-	X	-
R273.05X25.40-316-A999	-	X	-

Material 316L (1.4404)	Flange system				
	Surface pickled	Surface bright annealed	F37 Flare	F37 Retaining ring	HPF
		R12X1.5-316BA	-	X*	-
R16X2-316			X	X*	-
R18X2-316			X	X*	-
R20X2-316			X	-	-
R20X2.5-316			X	X*	-
R25X2.5-316			X	X*	-
R25X3-316			X	X*	-
R30X3-316			X	X*	-
R30X4-316			X	X*	-
R38X2.5-316			X	-	-
R38X3-316			X	-	-
R38X4-316			X	X*	-
R38X5-316			X	X*	-
R42X3-316			X	X*	-
R50X3-316			X	X*	-
R50X5-316			X	X*	-
R50X6-316			X	X*	-
R60X3-316			X	X*	-
R60X5-316			X	X*	-
R60X6-316			X	X*	-
R66X8.5-316			-	X	-
R73X7-316			-	X*	-
R75X3-316			X	X*	-
R75X5-316			X	X*	-
R80X10-316			-	X	-

X* = Retaining ring weld adapter

Other sizes on request!



Seamless EO steel tubes | Material E235+N / St.37.4 (1.0308)

Acc. to DIN EN 10305-1

1. DNV Bended pipe including manufacturing and corrosion tolerances.
2. DNV Straight pipe including manufacturing and corrosion tolerances.
3. Burst pressure (B.P.) calculation = Based on Tensile value, wall thickness tolerance not included.

Material E235+N / St.37.4 (1.0308)		d _a Outer-Ø (mm)	Outer-Ø Tolerance (mm)	s Wall- thickness (mm)	d _i Inner-Ø (mm)	Design pressure		3 Burst pressure bar	Weight kg/m
Surface						1 DNV PN bar	2 DNV PN bar		
Phosphated and oiled	Cr(VI)-free								
Order code									
R12X1.5	R12X1.5CF	12	±0.08	1.5	9.0	218	250	1114	0.388
R16X2	R16X2CF	16	±0.08	2.0	12.0	235	270	1114	0.691
R18X2	R18X2CF	18	±0.08	2.0	14.0	207	237	975	0.789
R20X2	R20X2CF	20	±0.08	2.0	16.0	185	212	867	0.888
R20X2.5	R20X2.5CF	20		2.5	15.0	246	282	1114	1.079
R25X2.5	R25X2.5CF	25	±0.08	2.5	20.0	193	221	867	1.387
R25X3	R25X3CF	25		3.0	19.0	242	277	1064	1.628
R30X3	R30X3CF	30	±0.08	3.0	24.0	198	227	867	1.998
R30X4	R30X4CF	30		4.0	22.0	281	323	1200	2.565
R38X3 R38X4 R38X5	R38X2.5CF	38	±0.15	2.5	33.0	124	141	549	2.189
	R38X3CF	38		3.0	32.0	154	176	669	2.589
	R38X4CF	38		4.0	30.0	217	248	918	3.354
	R38X5CF	38		5.0	28.0	282	324	1182	4.069
R42X2	R42X2CF	42	±0.20	2.0	38.0	85	97	390	1.973
R42X3	R42X3CF	42		3.0	36.0	139	158	600	2.885
R42X4	R42X4CF	42		4.0	34.0	194	223	821	3.748
R50X3	R50X3CF	50	±0.20	3.0	44.0	115	132	498	3.477
R50X6		50		6.0	38.0	258	296	1064	6.511
R60X3	R60X3CF	60	±0.25	3.0	54.0	95	109	411	4.217
R65X8		65	±0.30	8.0	49.0	270	310	1095	11.245
R75X3	R75X3CF	75	±0.35	3.0	69.0	76	86	325	5.327
R90X3.5	R90X3.5CF	90	±0.40	3.5	83.0	75	85	316	7.466
R100X4		100	±0.45	4.0	92.0	78	89	325	9.470
R115X4		115	±0.50	4.0	107.0	68	77	281	10.949
R140X4.5		140	±0.70	4.5	131.0	63	72	259	15.037
R165X5		165	±0.90	5.0	155.0	60	68	244	19.729
R220X6		220	±1.10	6.0	208.0	55	62	219	31.665
R273X6		273	±1.40	6.0	261.0	44	50	175	39.507

Surface finish:

- Tubes with I.D. 1.5-5 mm: outside and inside oiled.
- Tubes from 6 mm I.D.: outside and inside phosphated and oiled.

• Cr(VI)-free:

These dimensions are externally thick coat passivated (thickness of coat 8-12µm), inside oiled.

Other sizes on request!

Seamless EO steel tubes | Material E235+N / St.37.4 (1.0308)

Acc. to DIN EN 10305-1

1. DIN 2413 I static pressure (W.P.) capability for straight pipe including manufacturing tolerance.
2. DIN 2413 III dynamic pressure (W.P.) capability for straight pipe including manufacturing tolerance.
3. Burst pressure (B.P.) calculation acc. to Faupel-von-Mises

Material E235+N / St.37.4 (1.0308)		d _a Outer-Ø (mm)	Outer-Ø Tolerance (mm)	s Wall- thickness (mm)	d _i Inner-Ø (mm)	Design pressure		3 Burst pressure bar	Weight kg/m
Surface Phosphated and oiled	Cr(VI)-free					1 DIN 2413 I static PN bar	2 DIN 2413 III dynamic PN bar		
Order code									
R12X1.5	R12X1.5CF	12	±0.08	1.5	9.0	353	303	1022	0.388
R16X2	R16X2CF	16	±0.08	2.0	12.0	353	303	1022	0.691
R18X2	R18X2CF	18	±0.08	2.0	14.0	313	273	893	0.789
R20X2	R20X2CF	20	±0.08	2.0	16.0	282	248	793	0.888
R20X2.5	R20X2.5CF	20	±0.08	2.5	15.0	353	303	1022	1.079
R25X2.5	R25X2.5CF	25	±0.08	2.5	20.0	282	248	793	1.387
R25X3	R25X3CF	25	±0.08	3.0	19.0	338	292	975	1.628
R30X3	R30X3CF	30	±0.08	3.0	24.0	282	248	793	1.998
R30X4	R30X4CF	30	±0.08	4.0	22.0	376	321	1102	2.565
R38X3	R38X2.5CF	38	±0.15	2.5	33.0	186	168	501	2.189
R38X3	R38X3CF	38		3.0	32.0	223	199	610	2.589
R38X4	R38X4CF	38		4.0	30.0	297	260	840	3.354
R38X5	R38X5CF	38		5.0	28.0	371	318	1085	4.069
R42X2	R42X2CF	42	±0.20	2.0	38.0	134	123	355	1.973
R42X3	R42X3CF	42		3.0	36.0	201	181	547	2.885
R42X4	R42X4CF	42		4.0	34.0	269	237	750	3.748
R50X3	R50X3CF	50	±0.20	3.0	44.0	169	154	454	3.477
R50X6	R50X6CF	50		6.0	38.0	338	292	975	6.511
R60X3	R60X3CF	60	±0.25	3.0	54.0	141	129	374	4.217
R65X8		65	±0.30	8.0	49.0	347	299	1004	11.245
R75X3	R75X3CF	75	±0.35	3.0	69.0	113	104	296	5.327
R90X3.5	R90X3.5CF	90	±0.40	3.5	83.0	110	101	288	7.466
R100X4		100	±0.45	4.0	92.0	113	104	296	9.470
R115X4		115	±0.50	4.0	107.0	98	91	256	10.949
R140X4.5		140	±0.70	4.5	131.0	91	84	236	15.037
R165X5		165	±0.90	5.0	155.0	85	80	222	19.729
R220X6		220	±1.10	6.0	208.0	77	72	199	31.665
R273X6		273	±1.40	6.0	261.0	62	58	160	39.507

Surface finish:

- Tubes with I.D. 1.5-5 mm: outside and inside oiled.
- Tubes from 6 mm I.D.: outside and inside phosphated and oiled.

• Cr(VI)-free:

These dimensions are externally thick coat passivated (thickness of coat 8-12µm), inside oiled.

Other sizes on request!



Seamless E0 steel tubes | Material E355+N / St.52.4 (1.0580)

Acc. to DIN EN 10305-1

1. DNV Bended pipe including manufacturing and corrosion tolerances.
2. DNV Straight pipe including manufacturing and corrosion tolerances.
3. Burst pressure (B.P.) calculation = Based on Tensile value, wall thickness tolerance not included.

Material E355+N / St. 52.4 (1.0580)		d _a Outer-Ø (mm)	Outer-Ø Tolerance (mm)	s Wall- thickness (mm)	d _i Inner-Ø (mm)	Design pressure		3 Burst pressure bar	Weight kg/m
Surface Phosphated and oiled	Cr(VI)-free					1 DNV PN bar	2 DNV PN bar		
Order code									
	R12X1.5ST52CF	12	±0.08	1.5	9.0	330	378	1523	0.388
R16X2ST52	R16X2ST52CF	16	±0.08	2.0	12.0	355	408	1523	0.691
	R18X2ST52CF	18	±0.08	2.0	14.0	313	358	1333	0.789
R20X2ST52	R20X2ST52CF	20	±0.08	2.0	16.0	279	319	1184	0.888
R20X2.5ST52	R20X2.5ST52CF	20		2.5	15.0	371	426	1523	1.079
R25X3ST52	R25X2.5ST52CF	25	±0.08	2.5	20.0	291	333	1184	1.387
	R25X3ST52CF	25		3.0	19.0	365	418	1454	1.628
	R25X4ST52CF	25		4.0	17.0	519	599	2030	2.072
R30X3ST52	R30X3ST52CF	30	±0.08	3.0	24.0	299	343	1184	1.998
	R30X4ST52CF	30		4.0	22.0	424	487	1640	2.565
	R30X5ST52CF	30		5.0	20.0	555	641	2132	3.083
R38X4ST52	R38X3ST52CF	38	±0.15	3.0	32.0	233	266	914	2,589
	R38X4ST52CF	38		4.0	30.0	327	375	1254	3.354
	R38X5ST52CF	38		5.0	28.0	426	490	1615	4.069
	R38X6ST52CF	38		6.0	26.0	529	611	1999	4.735
	R39X7.5ST52CF	39	±0.15	7.5	24.0	673	781	2538	5.826
	R42X3ST52CF	42	±0.20	3.0	36.0	209	239	820	2.885
	R42X4ST52CF	42		4.0	34.0	294	336	1122	3.748
	R42X5ST52CF	42		5.0	32.0	381	438	1441	4.562
	R46X8ST52CF	46		±0.20	8.0	30.0	601	695	2244
R50X5ST52	R50X3ST52CF	50	±0.20	3.0	44.0	174	199	680	3.477
	R50X5ST52CF	50		5.0	40.0	315	361	1184	5.549
	R50X6ST52CF	50		6.0	38.0	390	448	1454	6.511
	R50X8ST52CF	50		8.0	34.0	546	631	2030	8.286
R56X8.5ST52	R56X8.5ST52CF	56	±0.25	8.5	39.0	516	595	1908	9.957
R60X6ST52	R60X3ST52CF	60	±0.25	3.0	54.0	144	164	561	4.217
	R60X5ST52CF	60		5.0	50.0	259	297	969	6.782
	R60X6ST52CF	60		6.0	48.0	319	366	1184	7.990
	R60X8ST52CF	60		8.0	44.0	445	512	1640	10.259
R60X10ST52		60		10.0	40.0	578	668	2132	12.331
	R65X8ST52CF	65	±0.30	8.0	49.0	407	468	1496	11.245
R66X8.5ST52	R66X8.5ST52CF	66	±0.30	8.5	49.0	429	494	1576	12.053
R73X7ST52	R73X7ST52CF	73	±0.35	7.0	59.0	308	353	1131	11.393
R75X5ST52	R75X5ST52CF	75	±0.35	5.0	65.0	205	234	761	8.631
R75X12.5ST52		75		12.5	50.0	583	674	2132	19.266
R80X3ST52		80	±0.35	3.0	74.0	107	122	415	5.697
R80X8ST52		80		8.0	64.0	325	372	1184	14.205
R80X10ST52		80		10.0	60.0	418	481	1523	17.263
R88X14ST52		88	±0.40	14.0	60.0	554	640	2017	25.549
R90X3.5ST52		90	±0.40	3.5	83.0	113	129	431	7.466
R90X5ST52		90		5.0	80.0	169	193	627	10.481
R90X9ST52		90		9.0	72.0	326	374	1184	17.978
R97X12ST52		97	±0.45	12.0	73.0	416	478	1505	25.154
R115X15ST52		115	±0.50	15.0	85.0	444	511	1599	36.992
R120X20ST52		120	±0.50	20.0	80.0	590	682	2132	49.322
R130X15ST52		130	±0.70	15.0	100.0	388	445	1390	42.540
R150X15ST52		150	±0.80	15.0	120.0	332	380	1184	49.939
R190X20ST52		190	±1.00	20.0	150.0	353	405	1254	83.847
R250X25ST52		250	±1.30	25.0	200.0	335	384	1184	138.718

Other sizes on request!

Seamless EO steel tubes | Material E355+N / St.52.4 (1.0580)

Acc. to DIN EN 10305-1

1. DIN 2413 I static pressure (W.P.) capability for straight pipe including manufacturing tolerance.
2. DIN 2413 III dynamic pressure (W.P.) capability for straight pipe including manufacturing tolerance.
3. Burst pressure (B.P.) calculation acc. to Faupel-von-Mises

Material E355+N / St. 52.4 (1.0580)		da Outer-Ø (mm)	OuterØ Tolerance (mm)	s Wal- thickness (mm)	di Inner-Ø (mm)	Design pressure		3 Burst pressure bar	Weight kg/m
Surface						1 DIN 2413 I static PN bar	2 DIN 2413 III dynamic PN bar		
Phosphated and oiled	Cr(VI)-free								
Order code									
	R12X1.5ST52CF	12	±0.08	1,5	9.0	533	357	1504	0.388
R16X2ST52	R16X2ST52CF	16	±0.08	2.0	12.0	533	357	1504	0.691
	R18X2ST52CF	18	±0.08	2.0	14.0	473	321	1314	0.789
R20X2ST52	R20X2ST52CF	20	±0.08	2.0	16.0	426	292	1167	0.888
R20X2.5ST52	R20X2.5ST52CF	20	±0.08	2.5	15.0	533	357	1504	1.079
	R25X2.5ST52CF	25		2.5	20.0	426	292	1167	1.387
R25X3ST52	R25X3ST52CF	25	±0.08	3.0	19.0	511	344	1435	1.628
	R25X4ST52CF	25		4.0	17.0	682	445	2016	2.072
R30X3ST52	R30X3ST52CF	30		3.0	24.0	426	292	1167	1.998
	R30X4ST52CF	30	±0.08	4.0	22.0	568	379	1622	2.565
	R30X5ST52CF	30		5.0	20.0	710	461	2120	3.083
R38X4ST52	R38X3ST52CF	38		3.0	32.0	336	234	899	2.589
	R38X4ST52CF	38	±0.15	4.0	30.0	448	306	1236	3.354
	R38X5ST52CF	38		5.0	28.0	561	374	1597	4.069
	R38X6ST52CF	38		6.0	26.0	673	440	1984	4.735
	R39X7.5ST52CF	39	±0.15	7.5	24.0	819	521	2539	5.826
	R42X3ST52CF	42		3.0	36.0	304	213	806	2.885
	R42X4ST52CF	42	±0.20	4.0	34.0	406	279	1105	3.748
	R42X5ST52CF	42		5.0	32.0	507	342	1422	4.562
	R46X8ST52CF	46	±0.20	8.0	30.0	741	478	2235	7.497
R50X5ST52	R50X3ST52CF	50		3.0	44.0	256	181	668	3.477
	R50X5ST52CF	50	±0.20	5.0	40.0	426	292	1167	5.549
	R50X6ST52CF	50		6.0	38.0	511	344	1435	6.511
	R50X8ST52CF	50		8.0	34.0	682	445	2016	8.286
R56X8.5ST52	R56X8.5ST52CF	56	±0.25	8.5	39.0	647	425	1892	9.957
R60X6ST52	R60X3ST52CF	60		3.0	54.0	213	152	551	4.217
	R60X5ST52CF	60	±0.25	5.0	50.0	355	247	953	6.782
	R60X6ST52CF	60		6.0	48.0	426	292	1167	7.990
	R60X8ST52CF	60		8.0	44.0	568	379	1622	10.259
R60X10ST52		60		10.0	40.0	710	461	2120	12.331
	R65X8ST52CF	65	±0.30	8.0	49.0	524	352	1477	11.245
R66X8.5ST52	R66X8.5ST52CF	66	±0.30	8.5	49.0	549	367	1557	12.053
R73X7ST52	R73X7ST52CF	73	±0.35	7.0	59.0	408	281	1113	11.393
R75X5ST52	R75X5ST52CF	75		5.0	65.0	284	200	748	8.631
R75X12.5ST52		75	±0.35	12.5	50.0	710	461	2120	19.266
R80X3ST52		80		3.0	74.0	160	115	408	5.697
R80X8ST52		80	±0.35	8.0	64.0	426	292	1167	14.205
R80X10ST52		80		10.0	60.0	533	357	1504	17.263
R88X14ST52		88	±0.40	14.0	60.0	678	443	2002	25.549
R90X3.5ST52		90		3.5	83.0	166	119	423	7.466
R90X5ST52		90	±0.40	5.0	80.0	237	168	616	10.481
R90X9ST52		90		9.0	72.0	426	292	1167	17.978
R97X12ST52		97	±0.45	12.0	73.0	527	354	1486	25.154
R115X15ST52		115	±0.50	15.0	85.0	556	371	1580	36.992
R120X20ST52		120	±0.50	20.0	80.0	710	461	2120	49.322
R130X15ST52		130	±0.70	15.0	100.0	492	332	1372	42.540
R150X15ST52		150	±0.80	15.0	120.0	426	292	1167	49.939
R190X20ST52		190	±1.00	20.0	150.0	448	306	1236	83.847
R250X25ST52		250	±1.30	25.0	200.0	426	292	1167	138.718

Other sizes on request!



Seamless cold drawn EO stainless steel tube | Material 316Ti (1.4571)

Acc. to DIN 10216-5, DIN EN 10305-1

1. DNV Bended pipe including manufacturing and corrosion tolerances.
2. DNV Straight pipe including manufacturing and corrosion resistance.
3. Burst pressure (B.P.) calculation = Based on Tensile value, wall thickness tolerance not included.

Material 316Ti (1.4571) Surface bright annealed Order code	d _a Outer-Ø (mm)	OuterAußen-Ø Tolerance (mm)	s Wall- thickness (mm)	d _i Inner-Ø (mm)	Design pressure		3 Burst pressure bar	Weight kg/m
					1 DNV PN bar	2 DNV PN bar		
					R12X1.571	12		
R16X271	16	±0.08	2.0	12.0	380	437	1514	0.701
R18X271	18	±0.08	2.0	14.0	334	383	1325	0.801
R20X271	20	±0.08	2.0	16.0	298	341	1178	0.901
R20X2.571	20		2.5	15.0	380	437	1514	1.096
R25X2.571	25	±0.08	2.5	20.0	298	341	1178	1.409
R25X371	25		3.0	19.0	363	418	1445	1.653
R30X371	30	±0.08	3.0	24.0	298	341	1178	2.028
R30X471	30		4.0	22.0	409	470	1631	2.604
R38X2.571	38	±0.15	2.5	33.0	190	217	746	2.222
R38X471	38		4.0	30.0	315	361	1247	3.405
R42X371	42		±0.20	3.0	36.0	207	237	815

Other sizes on request!

Seamless cold drawn EO stainless steel tube | Material 316Ti (1.4571)

Acc. to DIN 10216-5, DIN EN 10305-1

1. DIN 2413 I static pressure (W.P.) capability for straight pipe including manufacturing tolerance.
2. DIN 2413 III dynamic pressure (W.P.) capability for straight pipe including manufacturing tolerance.
3. Burst pressure (B.P.) calculation acc. to Faupel-von-Mises.

Material 316Ti (1.4571) Surface bright annealed Order code	d _a Outer-Ø (mm)	Outer-Ø Tolerance (mm)	s Wall- thickness (mm)	d _i Inner-Ø (mm)	Design pressure		3 Burst pressure bar	Weight kg/m
					1 DIN 2413 I static PN bar	2 DIN 2413 III dynamic PN bar		
					R12X1.571	12		
R16X271	16	±0.08	2.0	12.0	368	297	1229	0.701
R18X271	18	±0.08	2.0	14.0	327	267	1074	0.801
R20X271	20	±0.08	2.0	16.0	294	242	953	0.901
R20X2.571	20		2.5	15.0	368	297	1229	1.096
R25X2.571	25	±0.08	2.5	20.0	294	242	953	1.409
R25X371	25		3.0	19.0	353	286	1172	1.653
R30X371	30	±0.08	3.0	24.0	294	242	958	2.028
R30X471	30		4.0	22.0	392	314	1325	2.604
R38X2.571	38	±0.15	2.5	33.0	193	164	603	2.222
R38X471	38		4.0	30.0	309	254	1010	3.405
R42X371	42	±0.20	3.0	36.0	210	177	659	2.930

Other sizes on request!



Seamless cold drawn E0 stainless steel tube | Material 316L (1.4404)

Acc. to DIN 10216-5, DIN 10305-1 (-316BA); ASTM A269/A213 (-316)

1. DNV Bended pipe including manufacturing and corrosion tolerances.
2. DNV Straight pipe including manufacturing and corrosion tolerances.
3. Burst pressure (B.P.) calculation = Based on Tensile value, wall thickness tolerance not included.

Material 316L (1.4404)		d _a Outer-Ø (mm)	Outer-Ø Tolerance (mm)	s Wall- thickness (mm)	d _i Inner-Ø (mm)	Design pressure		3 Burst pressure bar	Weight kg/m
Surface pickled	bright annealed					1 DNV PN bar	2 DNV PN bar		
Order code									
	R12X1.5-316BA	12	±0.08	1.5	9.0	380	437	1514	0.394
R16X2-316		16	±0.08	2.0	12.0	380	437	1514	0.701
R18X2-316		18	±0.08	2.0	14.0	334	383	1325	0.801
R20X2-316		20	±0.08	2.0	16.0	298	341	1178	0.901
R20X2.5-316		20	±0.08	2.5	15.0	380	437	1514	1.096
R25X2.5-316		25	±0.08	2.5	20.0	298	341	1178	1.409
R25X3-316		25	±0.08	3.0	19.0	363	418	1445	1.653
R30X3-316		30	±0.08	3.0	24.0	298	341	1178	2.028
R30X4-316		30	±0.08	4.0	22.0	409	470	1631	2.604
R38X2.5-316		38	±0.15	2.5	33.0	190	217	746	2.222
R38X3-316		38	±0.15	3.0	32.0	231	264	909	2.629
R38X4-316		38	±0.15	4.0	30.0	315	361	1247	3.405
R38X5-316		38	±0.15	5.0	28.0	403	463	1606	4.132
R42X3-316		42	±0.20	3.0	36.0	207	237	815	2.930
R50X3-316		50	±0.20	3.0	44.0	173	197	677	3.531
R50X5-316		50	±0.20	5.0	40.0	298	341	1178	5.634
R50X6-316		50	±0.20	6.0	38.0	363	418	1445	6.611
R60X3-316		60	±0.25	3.0	54.0	143	163	558	4.282
R60X5-316		60	±0.25	5.0	50.0	244	280	964	6.886
R60X6-316		60	±0.25	6.0	48.0	298	341	1178	8.113
R66X8.5-316		66	±0.30	8.5	49.0	393	452	1567	12.238
R73X7-316		73	±0.35	7.0	59.0	284	326	1124	11.568
R75X3-316		75	±0.35	3.0	69.0	113	129	442	5.409
R75X5-316		75	±0.35	5.0	65.0	193	220	757	8.764
R80X10-316		80	±0.35	10.0	60.0	380	437	1514	17.528

Other sizes on request!

Seamless cold drawn EO stainless steel tube | Material 316L (1.4404)

Acc. to DIN 10216-5, DIN 10305-1 (-316BA); ASTM A269/A213 (-316)

1. Due to Parker's high quality standards, the pickled tubes (-316) are calculated according to the values of bright annealed tubes (-316BA). Nominal pressure calculation based on these mechanical properties requires certification in accordance with 3.1 - EN 10204, which confirms the mechanical properties
2. DIN 2413 I static pressure (W.P.) capability for straight pipe including manufacturing tolerance.
3. DIN 2413 III dynamic pressure (W.P.) capability for straight pipe including manufacturing tolerance.
4. Burst pressure (B.P.) calculation acc. to Faupel-von-Mises

Material 316L (1.4404)		d _a Outer-Ø (mm)	Outer-Ø Tolerance (mm)	s Wall- thickness (mm)	d _i Inner-Ø (mm)	Design pressure		4 Burst pressure bar	Weight kg/m
Surface						2 DIN 2413 I static PN bar	3 DIN 2413 III dynamic PN bar		
1 pickled	bright annealed								
Order code									
	R12X1.5-316BA	12	±0.08	1.5	9.0	368	297	1229	0.394
R16X2-316		16	±0.08	2.0	12.0	368	297	1229	0.701
R18X2-316		18	±0.08	2.0	14.0	327	267	1074	0.801
R20X2-316		20		2.0	16.0	294	242	953	0.901
R20X2.5-316		20	±0.08	2.5	15.0	368	297	1229	1.096
R25X2.5-316		25		2.5	20.0	294	242	953	1.409
R25X3-316		25	±0.08	3.0	19.0	353	286	1172	1.653
R30X3-316		30		3.0	24.0	294	242	953	2.028
R30X4-316		30	±0.08	4.0	22.0	392	314	1325	2.604
R38X2.5-316		38		2.5	33.0	193	164	603	2.222
R38X3-316		38		3.0	32.0	232	195	734	2.629
R38X4-316		38	±0.15	4.0	30.0	309	254	1010	3.405
R38X5-316		38		5.0	28.0	387	311	1305	4.132
R42X3-316		42	±0.20	3.0	36.0	210	177	659	2.930
R50X3-316		50		3.0	44.0	176	150	546	3.531
R50X5-316		50	±0.20	5.0	40.0	294	242	953	5.634
R50X6-316		50		6.0	38.0	353	286	1172	6.611
R60X3-316		60		3.0	54.0	147	126	450	4.282
R60X5-316		60	±0.25	5.0	50.0	245	205	779	6.886
R60X6-316		60		6.0	48.0	294	242	953	8.113
R66X8.5-316		66	±0.30	8.5	49.0	379	305	1272	12.238
R73X7-316		73	±0.35	7.0	59.0	282	233	910	11.568
R75X3-316		75		3.0	69.0	118	102	356	5.409
R75X5-316		75	±0.35	5.0	65.0	196	166	611	8.764
R80X10-316		80	±0.35	10.0	60.0	368	297	1229	17.528

Other sizes on request!



Seamless stainless steel tubes | Material 316L (1.4404)

Acc. to ASTM A312/A999

1. DNV Bended pipe including manufacturing and corrosion tolerances.
2. DNV Straight pipe including manufacturing and corrosion tolerances.
3. Burst pressure (B.P.) calculation = Based on Tensile value, wall thickness tolerance not included.

Material 316L (1.4404)	da Outer-Ø		s Wallthickness		di Inner-Ø (mm)	Design pressure		3 Burst pressure bar	Weight kg/m	
	SCH	mm	SCH	mm		1	2			
						DNV PN bar	DNV PN bar			
Surface pickled										
Order code										
R21.34X2.11-316	1/2"	21.34	SCH 10	2.11	17.12	241	277	1130	1.014	
R21.34X2.77-316			SCH 40	2.77	15.80	325	374	1536	1.285	
R21.34X3.73-316			SCH 80	3.73	13.88	456	527	2182	1.641	
R21.34X4.78-316			SCH 160	4.78	11.78	611	712	2973	1.977	
R26.67X2.11-316	3/4"	26.67	SCH 10	2.11	24.56	190	217	885	1.299	
R26.67X2.81-316			SCH 40	2.81	21.05	259	297	1213	1.713	
R26.67X3.91-316			SCH 80	3.91	18.85	373	430	1769	2.231	
R26.67X5.56-316			SCH 160	5.56	15.55	560	651	2713	2.943	
R33.40X2.77-316-A999	1"	33.40	SCH 10	2.77	27.86	200	228	931	2.125	
R33.40X3.38-316-A999			SCH 40	3.38	30.02	247	284	1160	2.541	
R33.40X4.55-316-A999			SCH 80	4.55	24.30	343	395	1624	3.287	
R33.40X6.35-316-A999			SCH 160	6.35	20.70	502	583	2418	4.301	
R42.16X2.77-316-A999	1 1/4"	42.16	SCH 10	2.77	36.62	156	178	724	2.735	
R42.16X3.56-316-A999			SCH 40	3.56	35.04	204	233	950	3.444	
R42.16X4.85-316-A999			SCH 80	4.85	32.46	285	327	1339	4.536	
R42.16X6.35-316-A999			SCH 160	6.35	29.46	384	443	1826	5.700	
R48.26X2.77-316-A999	1 1/2"	48.26	SCH 10	2.77	42.72	135	154	627	3.158	
R48.26X3.68-316-A999			SCH 40	3.68	40.90	183	209	850	4.112	
R48.26X5.08-316-A999			SCH 80	5.08	38.10	258	296	1212	5.498	
R48.26X7.14-316-A999			SCH 160	7.14	33.98	377	434	1788	7.359	
R60.33X2.77-316-A999	2"	60.33	SCH 10	2.77	54.76	107	122	496	3.990	
R60.33X3.91-316-A999			SCH 40	3.91	52.48	154	176	714	5.521	
R60.33X5.54-316-A999			SCH 80	5.54	49.22	223	255	1041	7.596	
R60.33X8.74-316-A999			SCH 160	8.74	42.82	368	424	1745	11.284	
R73.03X3.05-316-A999	2 1/2"	73.03	SCH 10	3.05	66.90	97	111	449	5.342	
R73.03X5.16-316-A999			SCH 40	5.16	62.68	168	192	783	8.765	
R73.03X7.01-316-A999			SCH 80	7.01	58.98	234	268	1094	11.583	
R73.03X9.53-316-A999			SCH 160	9.53	53.94	327	376	1546	15.146	
R88.90X3.05-316	3"	88.90	SCH 10	3.05	82.80	79	90	366	6.557	
R88.90X5.49-316-A999			SCH 40	5.49	77.92	146	167	678	11.466	
R88.90X7.62-316-A999			SCH 80	7.62	73.56	207	237	966	15.509	
R88.90X11.13-316-A999			SCH 160	11.13	66.64	312	359	1474	21.674	
R114.30X3.05-316	4"	114.30	SCH 10	3.05	108.20	61	70	282	8.496	
R114.30X6.02-316-A999			SCH 40	6.02	102.16	124	141	573	16.322	
R114.30X8.56-316-A999			SCH 80	8.56	97.18	179	205	834	22.665	
R114.30X13.49-316-A999			SCH 160	13.49	87.32	293	336	1378	34.053	
R141.30X6.55-316-A999	5"	141.30	SCH 40	6.55	128.20	108	123	501	22.101	
R141.30X9.53-316-A999			SCH 80	9.53	122.24	160	183	745	31.444	
R141.30X15.88-316-A999			SCH 160	15.88	109.54	277	318	1304	49.871	
R168.28X3.40-316	6"	168.28	SCH 10	3.40	161.48	46	53	212	14.039	
R168.28X7.11-316-A999			SCH 40	7.11	154.08	98	112	454	28.697	
R168.28X18.26-316-A999			SCH 160	18.26	131.78	267	306	1254	68.603	
R219.08X8.18-316	8"	219.08	SCH 40	8.18	202.72	87	99	399	43.202	
R219.08X23.01-316-A999			SCH 160	23.01	173.06	258	296	1209	112.981	
R273.05X25.40-316-A999	10"	273.05	XXS	25.40	222.25	226	259	1057	157.509	

Other sizes on request!

Conversion tables

Temperature conversion table

Celsius to Fahrenheit

°C	°F
150	302
145	293
140	284
135	275
130	266
125	257
120	248
115	239
110	230
105	221
100	212
95	203
90	194
85	185
80	176
75	167
70	158
65	149
60	140
55	131
50	122
45	113
40	104
35	95
30	86
25	77
20	68
15	59
10	50
5	41
0	32
-5	23
-10	14
-15	5
-20	-4
-25	-13
-30	-22
-35	-31
-40	-40
-45	-49
-50	-58

Fahrenheit to Celsius

°F	°C
340	171
330	166
320	160
310	154
300	149
290	143
280	138
270	132
260	127
250	121
240	116
230	110
220	104
210	99
200	93
190	88
180	82
170	77
160	71
150	66
140	60
130	54
120	49
110	43
100	38
90	32
80	27
70	21
60	16
50	10
40	4
30	-1
20	-7
10	-12
0	-18
-10	-23
-20	-29
-30	-34
-40	-40
-50	-46
-60	-51

Pressure conversion table

bar to psi

bar	psi
1000	14505
800	11604
600	8703
500	7253
400	5802
250	3626
160	2321
100	1451
60	870
40	580
35	508
25	363
16	232
10	145
6	87
4	58
2.5	36
1.6	23
1	15

psi to bar

psi	bar
10000	689
9000	620
7000	483
6000	414
4000	276
3000	207
2500	172
1000	69
900	62
600	41
500	34
400	28
250	17
150	10.3
100	6.9
90	6.2
60	4.1
40	2.8
25	1.7
10	0.7

Examples

Temperature conversion

Initial value: 100
 °C to °F: 212 °F
 °F to °C: 37,78 °C

Pressure conversion

Initial value: 35
 bar to psi: 507.675 psi
 psi to bar: 2.41296 bar

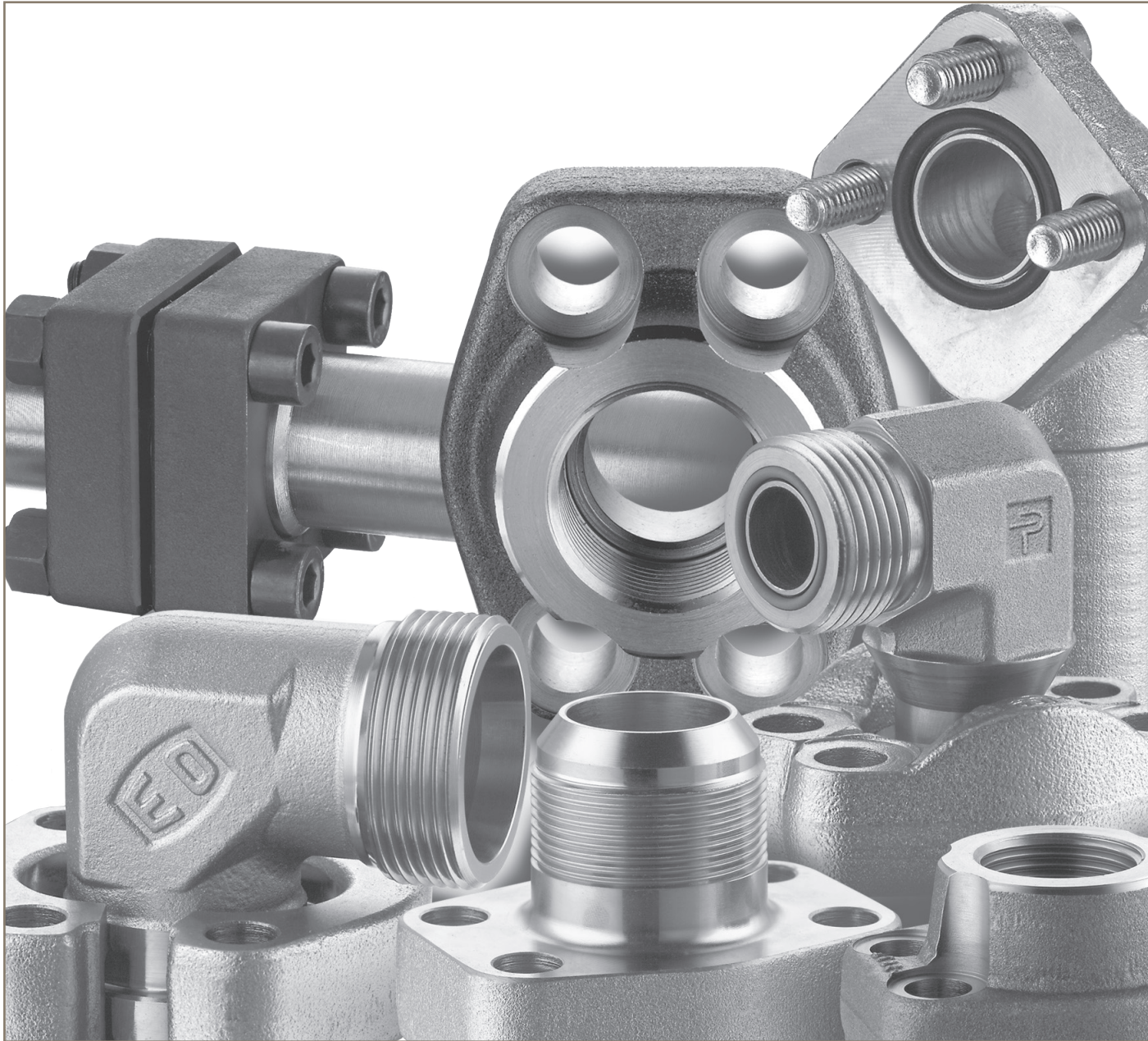

SAE Flange adapters

For a full range of SAE and ISO Flange Connectors, Pump Flanges and Flange Accessories please see Catalogue 4100 Chapter M.

www.parker.com/hpce ↴

Resources ↴

General Documentation

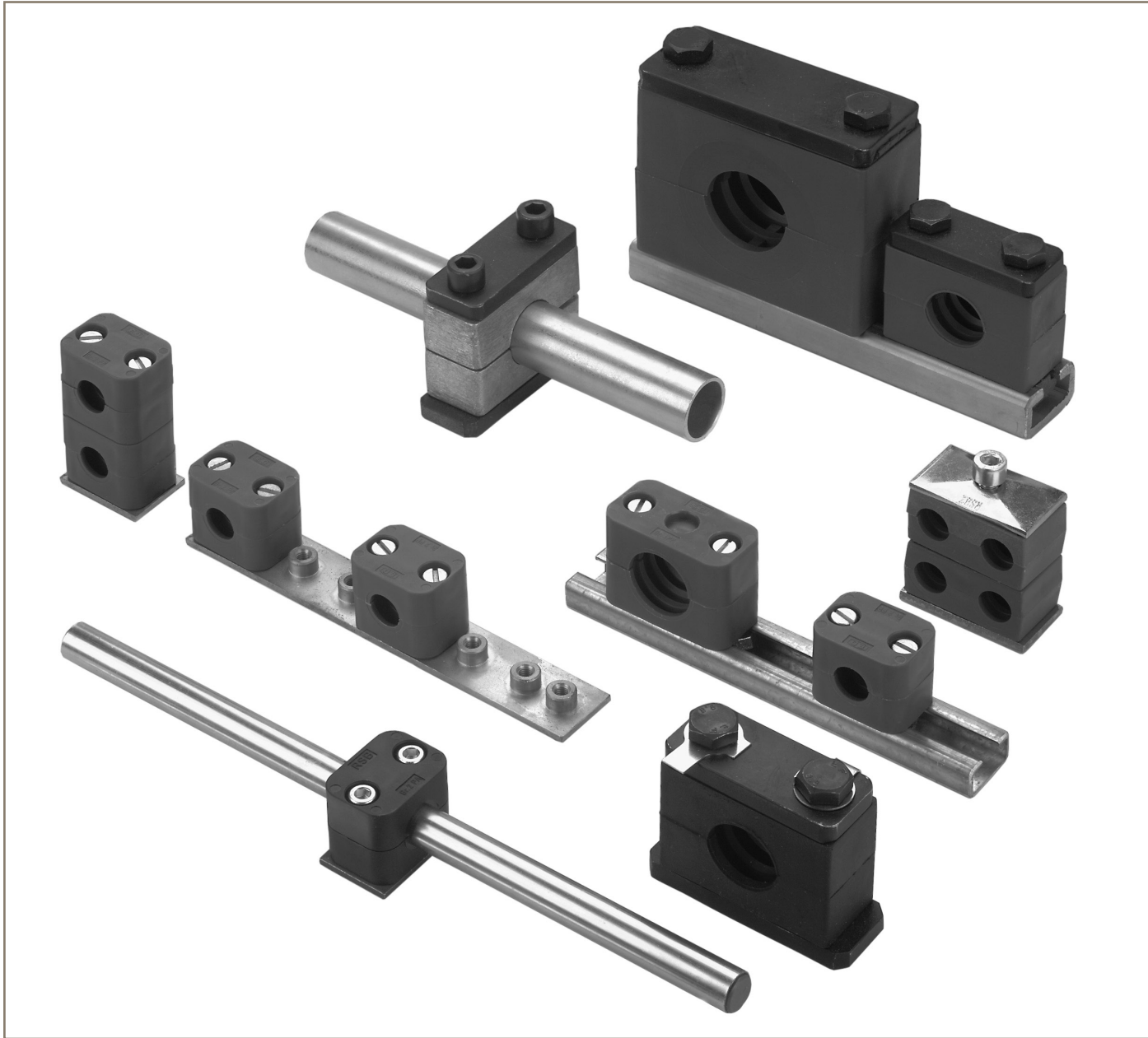

Tube clamps

For a full range of Tube Clamps according to DIN3015 and other clamp solutions please see Catalogue 4100 Chapter S.

www.parker.com/hpce 
Resources 
General Documentation

Table of contents

Introduction..... page 4

General information..... 5

Technical data..... 17

Installation 23

Machines, tooling and equipment 25

Ordering information/Nomenclature 33

SAE 1000 System..... 37

SAE 3000 System..... 59

SAE 6000 System..... 99

ISO 6164 System 139

Pipes and tubes..... 173

High Pressure Connectors Europe

The Tube Fittings Authority:

Performance Plus

Since 1929, Parker Hannifin Corporation has served the marketplace with dependable fluid power technology. Today, Parker offers more than 100,000 quality products for a broad range of industries and applications. No other manufacturer presents a product line as broad as Parker's, nor an expertise as far-reaching in hydraulic and pneumatic systems and components. Much of that expertise originates with Parker's precision-made tube fittings, which were among the first products manufactured by the company. As such, they reflect Parker's ongoing commitment to excellence.

With more than seventy years of experience in product design, engineering, applications technology and manufacturing, the High Pressure Connectors Europe division holds a leadership position few other manufacturers can claim. This leadership is further heightened and enhanced by the sharing of technology only possible in Parker's corporate family.

Topflight Experience

Parker has used the background data and knowledge gained from important industrial, mobile, offshore and other applications to create the broadest and best performing line of standard tube fittings in the world.

Why is Parker a topflight manufacturer of fittings?

There are many reasons, but at the heart is the design and manufacturing excellence that goes into every Parker product.

Worldwide standardizing activities

The Parker Fluid Connectors Group supports the national and international standardizing activities. Experienced engineers from certain countries and Divisions give their input to national committees like SAE, BS, and DIN committees in cooperation with the users of the products. As a result, many ISO Fluid Connector standards have been published. These ISO standards are the platform for the international trading, interchangeability and availability that is necessary for all globally operating companies using fluid power technology.



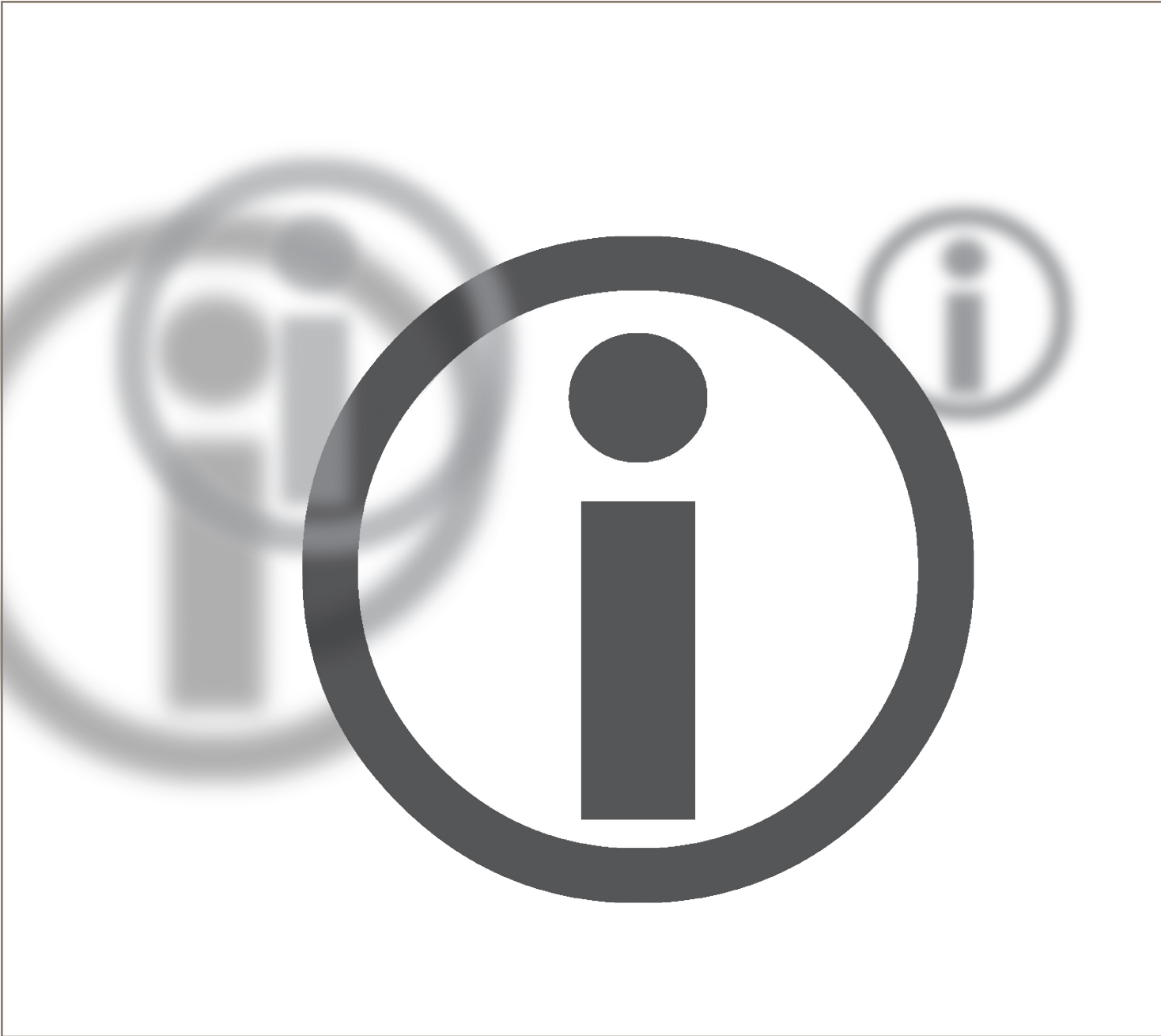

General information

Parflange® F37 technology

Parflange® technology

Parker is the inventor of the Parflange® system and knows well how to deal with flared tubes and flanged connectors. The excellent sealing performance and the high mechanical strength of Parflange® technology are achieved by continuous orbital tube forming. Proven millions of times, this connector system is backed by decades of experience. The Parflange® system belongs to Parker's leak-free Dry Technology programme. Dry Technology stands for leak-free systems with soft sealing at every connection point.

Parflange® F37

The Parflange® F37 flanged connector system is utilising this orbital tube forming technology for tubing assemblies from 16 to 168.3 mm (1/2" to 6" Flanges) outside diameter. It is intended for tube wall thickness up to 9 mm and pressure ratings up to 420 bar.

For those connections, where there is no possibility to assemble a pre-flared tube or where manufacturing is limited, Parker provides the F37 Retaining Ring System. This System utilizes a Retaining Ring for flange retention along with a highly-engineered seal carrier for leak free performance. It is available as a high pressure version from 1 1/2" to 12" and as a 1000 PSI version for lower pressures up to 50-70 bar.

The Parflange® F37 system corresponds to hole patterns according to ISO 6162-1; SAE J518; bore pattern 3000 (code 61), ISO 6162-2; bore pattern 6000 (code 62) and also ISO 6164 bore pattern.

It is type approved by DNV, ABS and other major classification companies.

Protected from corrosion and even Cr(VI)-free

As a manufacturer of large flange connectors, Parker is employing Cr(VI)-free corrosion protection on Parflange F37, as it has already done with its other Fluid Connector Products. The removal of Cr(VI) reflects Parker's ongoing commitment to an environmentally clean and safe production process.

Different Sealing Solution

The F37 seal was developed especially for use with SAE flanges. These special seals guarantee high stability of form. Compared to standard O-Rings, their mechanical properties prevent gap extrusion, even when the flanges "breathe" under pressure. The special profile of the F37 seal is ideally adapted to higher pressures or unsuitable surface finish of the flanges. As an alternative, connectors can be equipped with bonded seal rings.

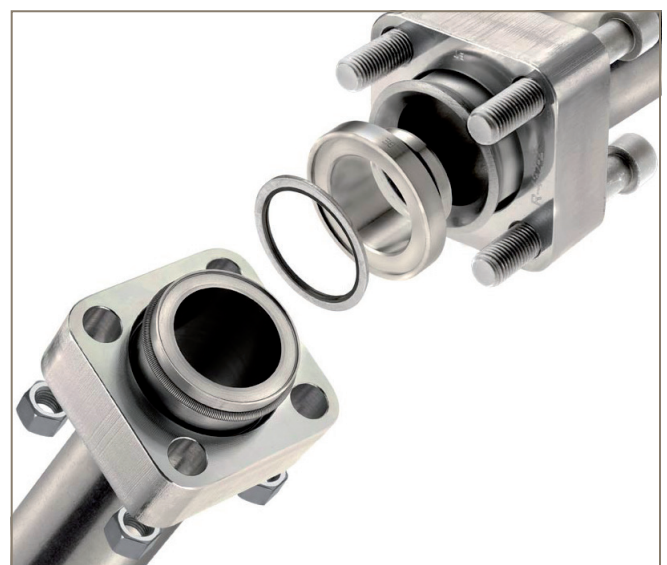
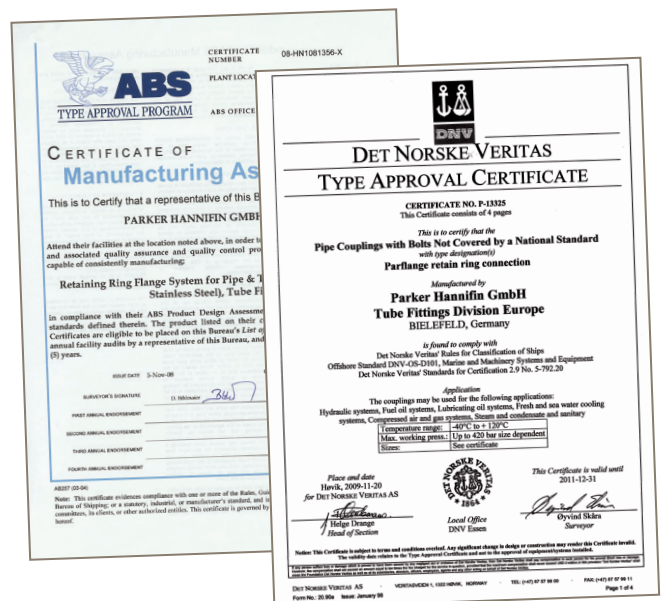
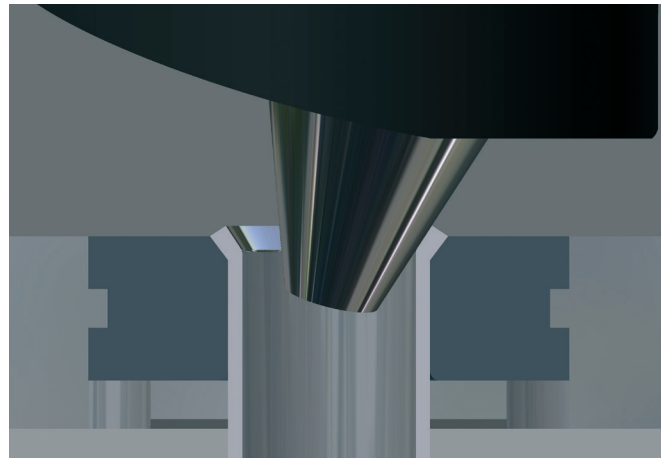

Parflange® F37 technology

Flaring Machine (Adjustable)

For smaller tube connecting projects such as the on-site maintenance of, for example, drilling platforms or ships, the Parflange® ECO for processing steel and stainless steel tube is available.

The machine works to the Parflange® process, proven millions of times over, affording maximum mechanical accuracy and reliability. It does not require any complicated programming or operation to manufacture rapidly smaller quantities up to 168.3 mm outside diameter. The maximum capacity of the machine is around 5 mm wall thickness for a 165 mm tube at a remarkably short cycle time of 30 to 60 seconds for the flaring and 1 to 2 minutes for the total operation. Other tube diameter allow even thicker tube wall.



Complete range for virtually all diameters

The F37 system complements the EO-2 soft sealing technology for small tube diameters; it also complements the proven Parflange® programme for the SAE product range. It offers the complete range of connectors, flange-to-flange, L- and T-Block connectors, flange-to-port, male and female thread flanges, flange bends, reducer flanges, bulkhead flanges and manifolds on request.

The F37-Programme - a savings programme

F37 is the way to reduce manufacturing times enormously. By comparing welded connections with Parker flange connector systems, significant opportunities for cost savings become immediately obvious

1. Cutting and deburring tubes
2. Tube preparation for the "connecting process"
3. Welding and/or assembling
4. Inspection (X-ray) of welded connectors
5. Flushing the connected tubes
6. Applying corrosion protection

In comparison with this, weld-free tube forming save time and costs. Expensive cleaning and X-raying of the tube connector become immediately things of the past. The manufacturing time for a tube connector quickly reduces by more than half in comparison with conventional welding. To make this clear, Parker has developed a calculator which, on the basis of the individual input data, determines the exact cost saving from

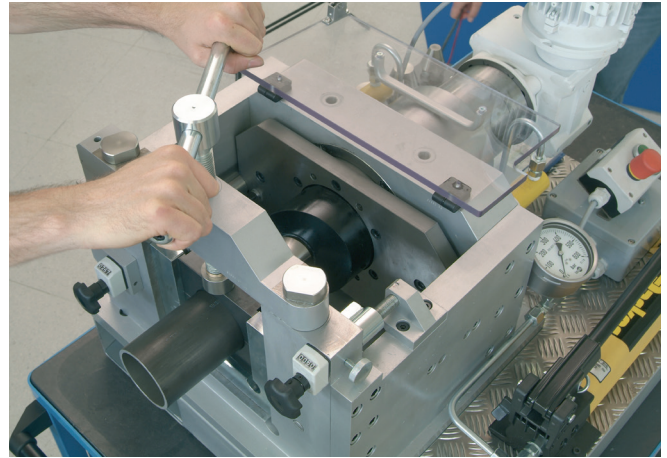

Parflange® F37 technology

using Parflange® F37 and/or the high-performance flange connectors. Parker flange connector systems accommodate even higher requirements, especially those from the offshore industry, shipbuilding, heavy machinery construction and press manufacture, as well as from mining, recycling plants and mobile machinery; overall in power piping systems.

Personnel and environment-friendly

By comparing the individual operations for a welded line with Parker flanges connected lines, significant cost savings opportunities become immediately obvious. No vapours putting health at risk are released, in contrast to conventional welding processes. Consequently, usage is possible in locations with high requirements such as, for example, offshore oil platforms. In addition to this flaring machine design errors in the preparation of flanges are virtually unknown. Stress corrosion cracking generated during welding operations is history and the life of the finished tubing system is increased. Cold formed Parflange® technologies save power and energy compared to welding and require neither degreasers nor anti-corrosion agents. When galvanized tubes are used, post-galvanization can be omitted because the zinc-coating is not impaired by flaring. Parker flange connector components are delivered in state of the art Cr(VI)-free surfaces.

We deliver all the component parts securely packed to the required location. Reliable delivery on the date advised. And then we come to professional assembly – our specialists will willingly take it on for you. After testing and a trial run, you can press the start button to make your production a success.

Principles account for success

The concept of this system is the customer interaction with advice, design, preassembly (with fittings, flanges and machined tubes), delivery and installation as a complete package cannot be beaten. Supportive planning, high-quality products and safe working processes offer the ultimate synergy in time and cost saving. And of course, individual Piping Solutions principles are also available to you.

The Parker Piping Solutions concept principles:	
Advise	Briefing/ Design discussion
Design	Tubing layout Tube dimensioning Drawings Documentation
Pre-assemble	Tube bending Flaring Tube cleaning
Deliver	Assemble/dispatch Documentation
Install	Manufacturing On site management On site assembly Inspect and wash Documentation

Feature	Customer Value
No welding	- Reduced preparation time per joint - No costly inspection of welds (X-ray)
No post-weld cleaning	- No acid cleaning costs - No waste cleaning costs - No safety risk - Environmentally friendly
No welding stress corrosion possible	- Maximum piping lifetime - Reduced maintenance costs
No „hot work“ permit required	- Operation can take place in areas with fire risk without interruption of production - Reduced downtime costs - Higher level of safety
Work shop prefabrication	- High quality joints with better accuracy due to workshop conditions - Minimized need for on-site work - Shorter installation time - Shorter maintenance/downtime - Shorter total project time
Cleanliness	- Minimized need for repair and replacement of hydraulic system components such as pumps, cylinders,... - Reduced overall flushing time and costs
Easy dismantling and reassembling	- Quicker, easier and more flexible installation - Reduced downtime costs for maintenance and repair



Connection technology

The Parflange® F37 Programme consists of two flange connection technologies:
The 37° Flare Flange Connection and the Retaining Ring Connection.

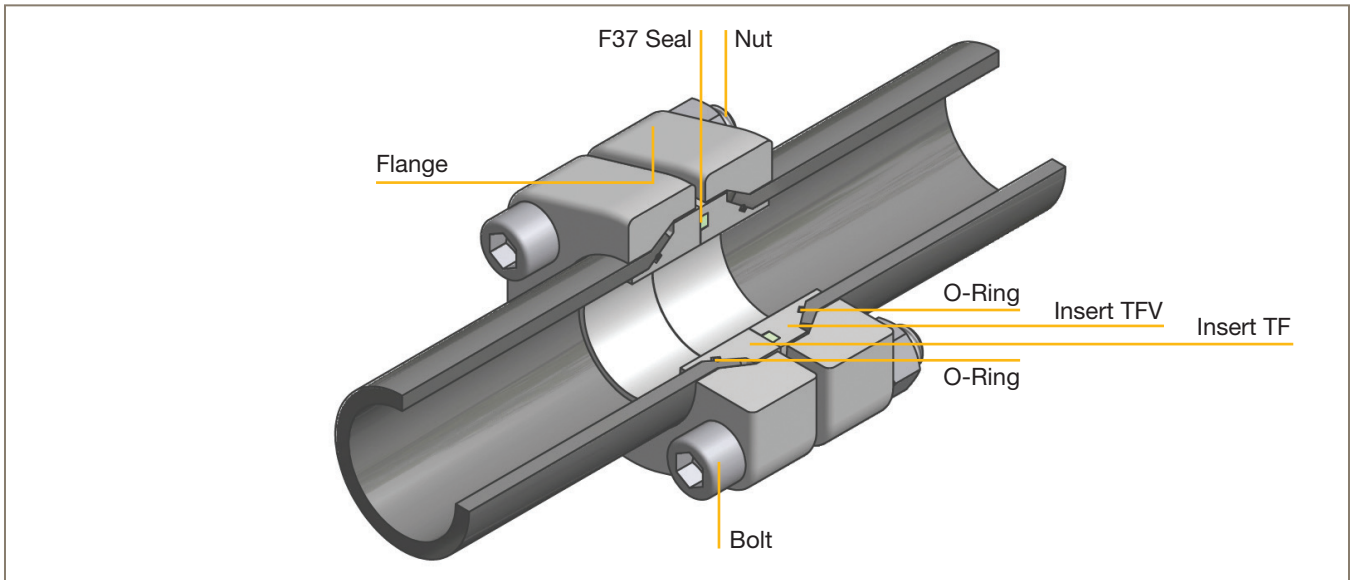

Parflange® F37 Flare Flanges - In this configuration, the deburred tube end is flared orbitally to 37° by Parflange® technology. An insert, soft sealed by an O-Ring, is located into each pipe end. In between a F37 Seal (optionally Bonded Seal or O-Ring) is placed. By tightening the flanges together, a soft sealed, high pressure tube connection is made. Available as tube-to-tube connection or tube-to-port connection.

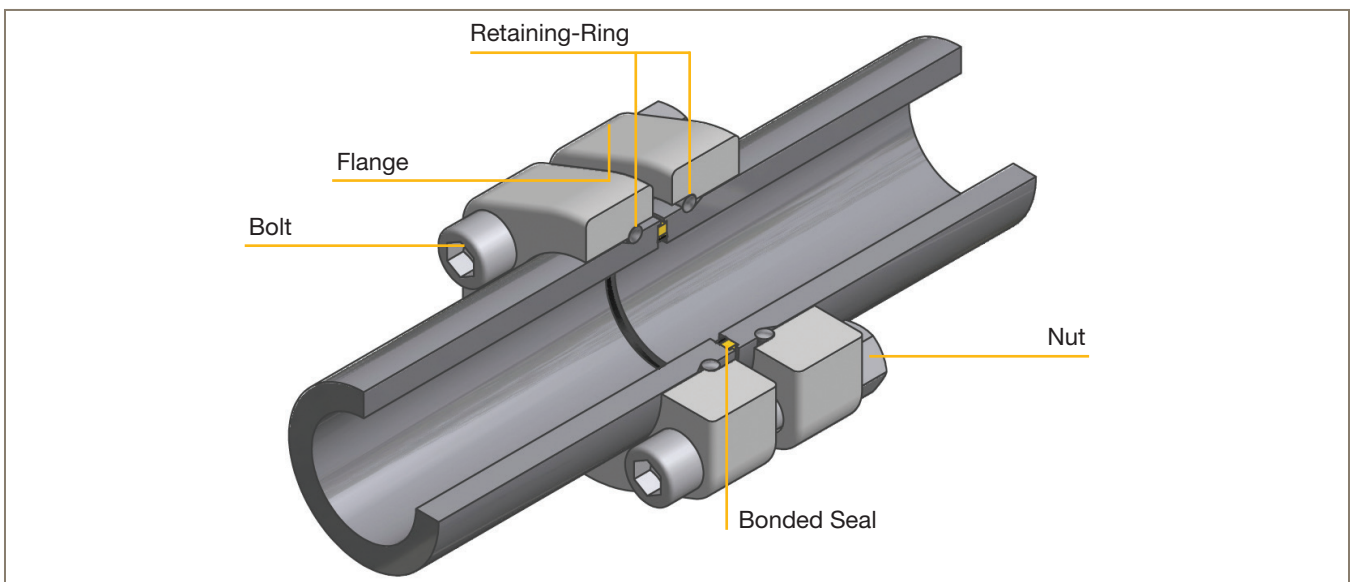

Retaining Ring Connection - The retaining ring used in this connection is a stainless steel segmented ring covered by a stainless steel spring. It is assembled in a machined groove on the tube end or adapter. When tightening this system, the flange is pushed against the retaining ring, thus giving a form tight connection. Retaining ring connections complete the Parflange® F37 range with bulkhead, male, female, weld and tube bend connections.

Connection methods F37 – Flared tube

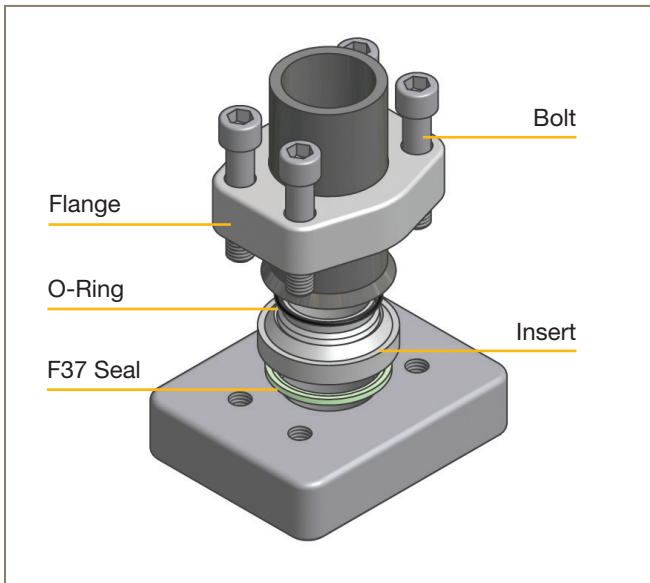

Flange to Port – the flanged tube is connected by the flange, insert and F37 seal to a port. Inserts with Bonded Seal can be used alternatively.

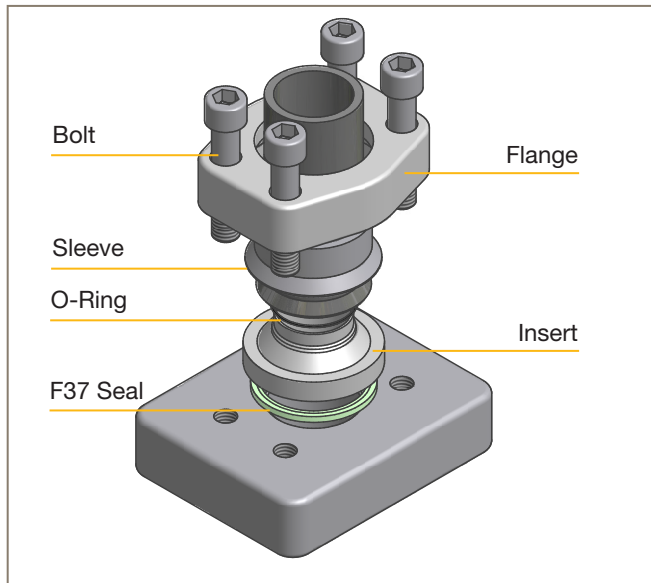

Flange to Port – the standard F37 Flanges can be used with adapter sleeve for smaller tube sizes as well.

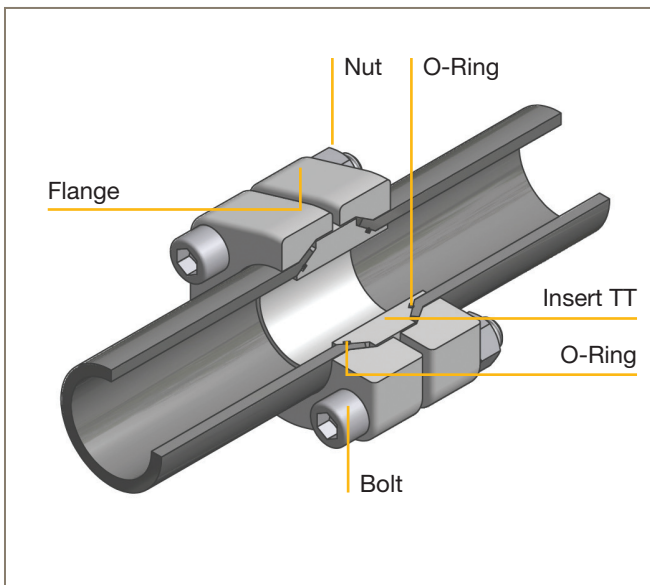

Tube to Tube – two flanges and one insert connecting two flared tubes. A two insert solution with F37 Seal or Bonded Seal is optional.

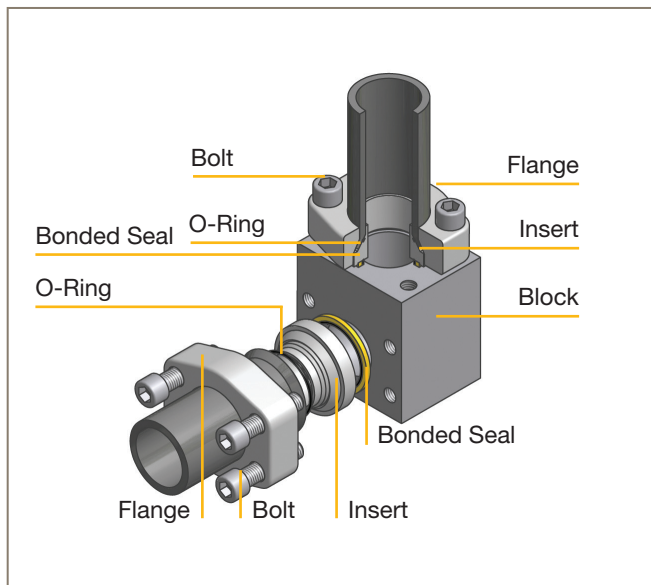

Tube to Block – instead of using flange bends compact L-Blocks are available. The range is completed by T-Blocks and Reducing Blocks. Special Manifolds according to customer design available on request.

Connection methods – Retaining ring

The Retaining Ring Flanges are – like the flanges for the F37 range – according to ISO 6162-1/2 and ISO 6164 footprint. Therefore any combination of the systems is possible.

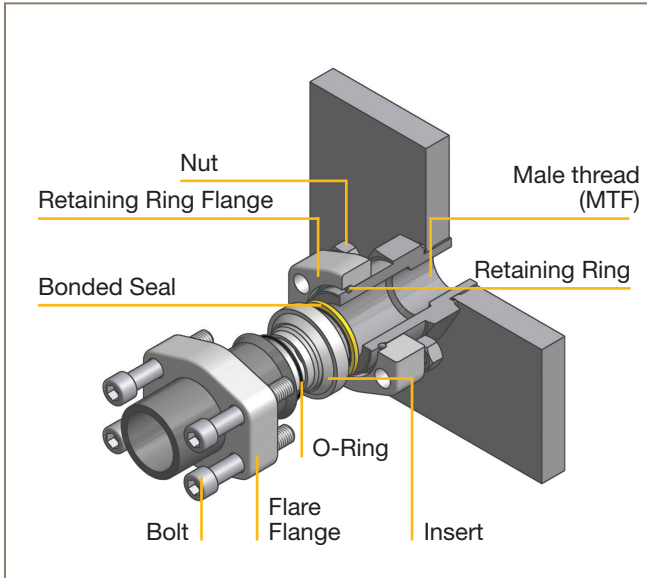

Male Thread Connection – Male Stud ends are delivered with soft seal ED end on one side and the Retaining Ring connection on the other side.

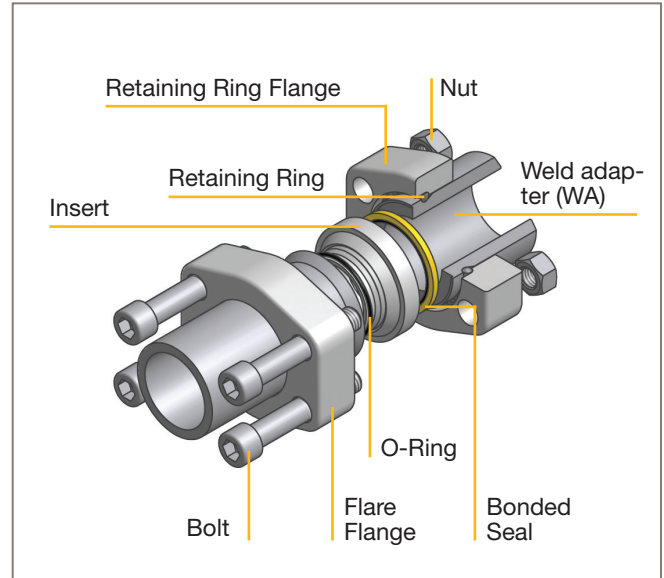

Weld Adapter – Weld adapters are delivered with weld end on one side and the Retaining Ring connection on the other side.

Complete Piping Solutions

Homogeneous solutions offer efficiency

From Components to full service.

Parker offers you the competent complete solution for hydraulic systems. From advice via design and pre-configuring to delivery and installation - everything with the best quality and reliability. You only have one contact. You take the pressure off your own team, release capacity and overall save a lot of time. You achieve new efficiency at high pressure.

Excellent complete solution.

Complete Piping Solutions from Parker are always to the customer's advantage. Equally high quality in all areas and available around the world.

The complete solution from a single source frees up customer capacity and lowers the need for customers to provide coordination effort. As a supplier of piping system solutions we offer our customers significant added value.

Advantages that pay off.

- High-quality system technology
- Saves time
- Saves money
- Customised user solutions
- Environmentally friendly
- Global supply
- Integration into existing systems

Advice	Briefing/design meeting
Design	Pipe layout Pipe dimensioning Drawings Documentation
Prefabrication	Pipe bending Pipe end processing Pipe cleaning
Delivery	Assembly/ Dispatch Documentation
Assembly	On-site advice On-site assembly Testing and flushing Documentation



Pipe bending



Complete Piping Solutions

The complete solution for hydraulic systems

The Parker Complete Piping Solutions concept can be used in the most varied and demanding applications. These include shipbuilding, the oil industry, steel plants and other industrial applications. Parker piping solutions offer you the competent complete solution for hydraulic systems.

Starting with the design via pre-configuring to delivery and installation,



everything produced by Parker is top quality and extremely reliable. Even at an early stage of designing machines and systems, Parker engineers and technicians are available

to you to provide ideal assistance for the development of hydraulic line systems.

The support offered to you by Parker includes a suggestion for the type of connection (product to be used) and the choice of materials to be deployed starting with the lines and even the seals. The manufacture of special components, e.g. blocks or manifolds, is no problem for Parker.

If you have no opportunity for line configuration and assembly Parker is there and able to provide advice with its Complete Piping Solutions concept. It is completely irrelevant whether this is an initial fitting or modernising a machine or equipment. Parker's service covers measuring, preparing the pipeline flange connections, including the pipe flanges and assembling the connections.

Such customised mechanical hydraulic connections offer massive time savings during conversion, expansion or disassembly.



Machine preparation for the bending process



Delivery of components in secure packaging

ENGINEERING YOUR SUCCESS.

Our customer solutions

Achieving more together

Parker is highly successful with its weld-free piping systems for many applications.



In the Offshoremarket these are pipes for such different ship types as suction dredgers, work ships to install and supply oil platforms, ferries and installation ships for the wind industry. The most varied of hydraulic systems can be given Parflange F37 connections. Piping solutions are also created for drilling and transport towers, crane systems and hoists using Parker's weld-free systems.

It is always about fast, low-cost completion and installation. Weld-free systems enable customers to respond quickly and efficiently to new projects and generate new business. The hydraulic systems in plant and mechanical engineering are also equipped with the Parflange® F37 system. These are the hydraulic, cooling system and return lines.

Customers often have to fight against long manufacturing lead times for a new machine.

If for instance a main ring line for a cooling system needs to be welded, time passes before the final installation on the machine can take place. This is the result of such matters as the set-up and cleaning times for the pipe.

Other power piping applications include renewable energy industries (wind power, water power). Also vehicle construction (car, truck test stands) and general mechanical engineering (wood processing machines, press construction, waste processing).

Precision and flexibility are essential for all applications. Orientable flanges give the pipe fitter greater flexibility during assembly.

The Parflange® F37 machine (WCM-WorkCentre Model) offered by Parker gives the customer a high level of flexibility for on-site assembly.

In summary, the weld-free connection systems from Parker achieve a high level of financial and time savings, flexibility, precision, quality and reliability. And this is associated with extraordinary customer and delivery service.



Centrally located at the heart of Europe

Complete Piping Solutions Centre in Augustdorf



As a result of the global piping strategy introduced by Parker Hannifin some time ago, there is now also a German piping centre close to Bielefeld (in Augustdorf). The German CPS (Complete Piping Solutions) has a strategic location close to the Parker factory at Bielefeld-Windelsbleiche and the European Distribution Center (EDC). The CPS Germany offers comprehensive options for customer-specific piping system solutions. Piping

system solutions are developed in line with customer requirements and requests, in the newly designed office areas with modern IT equipment. The complete production process is characterised by optimised routes for materials ordering, manufacturing and then dispatch. The flow of goods has been copied from the existing piping centres and the associated positive experience gained.



Locations of the global Parker Piping Solutions Centres

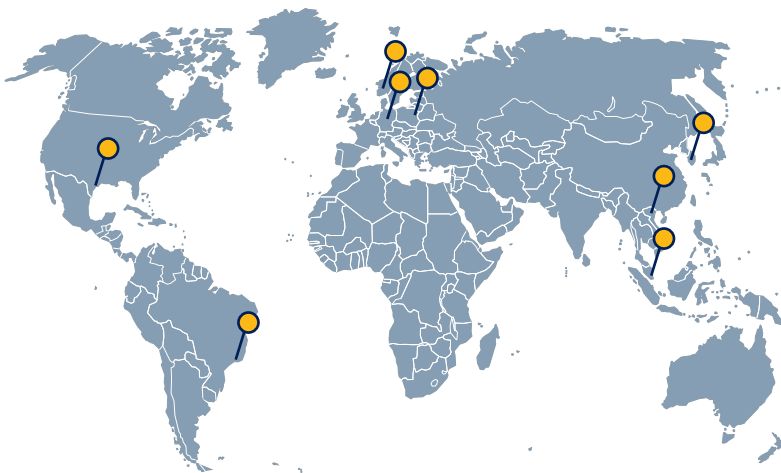

The functional workshop can process pipes with external diameters up to 220 mm on the modern CNC bending machines. These machines can also realise 2xD to 3XD bending radii which are defined as standard for the relevant pipe diameters. The other machines also match the high quality standard used by Parker.

ENGINEERING YOUR SUCCESS.

The requirements increase

So does our performance

In order to comply with the market and customer requirements in this segment we have aligned our performance to this. The following overview aims to emphasise the range of services offered by CPS Germany.

Development and design:

- Modern CAD systems can process all common 3D and 2D data formats and simulate installation situations
- The projects are produced as required by or in cooperation with the customer. These may be new systems or upgrades
- It may require taking pipe measurements on-site using a modern measurement system. These data can be handed over to the CAD System
- Data from the measurement system are used later for quality control in order to ensure an ideal and secure production process

Cold bending:

- After creating the data required for production these are transferred to the machines. The available bending machines process tubes with diameters from 6 x 1 mm to 190 x 20 mm (thin-walled \varnothing 220 x 6 mm)

Tube end processing:

- Modern CNC controlled machines are available for processing pipe ends. Tube end processing is carried out based on internal standards

Tube cleaning:

- Tube cleaning using the ISO 4406 / NAS 1638 standard
- Permanent control of the pollution and cleanliness level with modern measuring devices

Pressure test:

- Pressure test to customer specifications possible
- Documentation at the customer's request



Installation / support:

- Delivery of pre-configured tube systems to the customer's desired address
- Installation of tube systems whilst taking into account the parameters and work steps set in the installation manual
- Installation by end customer training conducted by Parker



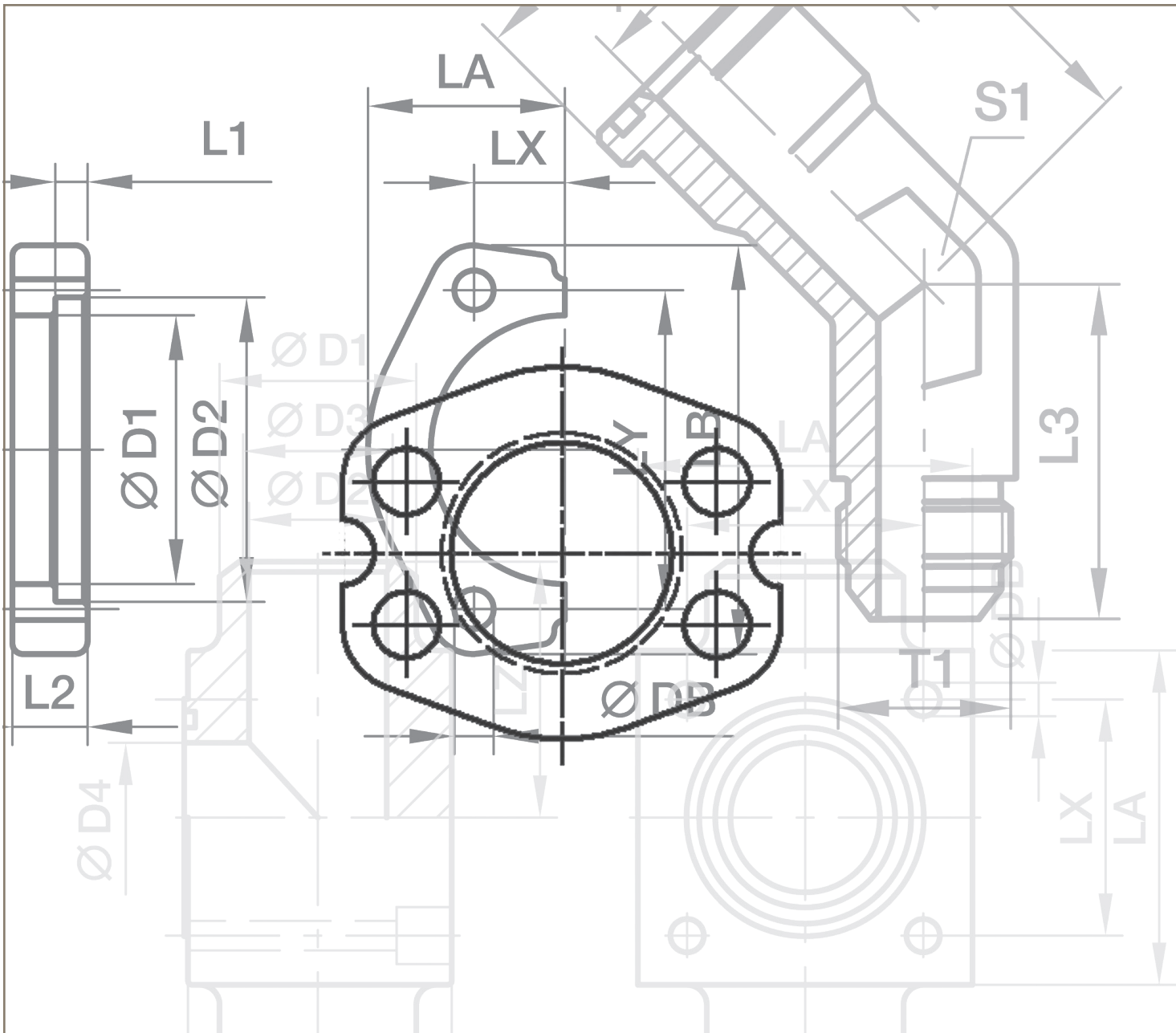

Technical data

Flange connection selection guide

To ensure the correct component selection for each application the following needs to be checked:



- Maximum operating pressure (pressure peaks to be considered)
(Check design pressure for the components involved in the connection.)
- Component material selection
Component material (steel, stainless steel, duplex, ...) suitable to corrosivity of medium and environment.
In case of mixed materials, the electrochemical difference and its resulting corrosion potential needs to be considered. In some cases, it is advisable to exclude the environmental influence (e.g., by using "denso tape").
- Medium compatibility
Check fluid compatibility chart on page 20.
- Medium and environment temperature
Calculate the allowable component working pressure in dependency of the medium and environment temperature according to pressure reduction table below.

Pressure reductions and temperatures for flanges and connection components

Required pressure reductions (depending on the material) with reference to the catalogue pressures for higher temperatures. Both metal fitting material and elastomeric sealing compound have to be selected according to the temperature range of the system.

DNV may require different pressure reduction based on application

Material	Pressure reduction of permissible operating temperatures TB in °C															
	-60	-54	-40	-35	-25	+20	+50	+100	+120	+150	+175	+200	+250	+300	+400	
Steel components			-10%			0%					-11%	-19%				
Steel, tubes			-10%			0%					-19%		-27%			
Stainless steel components	0%						-5%	-15%	-23%		-29%		-33%	-37%	-42%	
Stainless steel, tubes	0%						-5.5%	-11.5%	-21.5%			-29%		-34%		
Sealing material NBR (e.g. Perbunan)																
Sealing material FKM																
Sealing material Polyurethan (P5008)																

-  Permitted operating temperature
-  Permitted ambient temperature of hydraulic and pneumatic applications
-  Temperature not permitted

Calculation example:
 Temperature = 200°C
 Material = Stainless steel
 Pressure reduction = 29%
 Pressure reduction tubes = 21.5%
 PN tube 16x2.5/71. DIN2413 III = 362 bar

Formula:

$$PN_{200^{\circ}\text{C}} = \frac{400 \text{ bar}}{100\%} \times (100\% - 29\%) = 284 \text{ bar}$$

$$PN_{\text{tube } 200^{\circ}\text{C}} = \frac{362 \text{ bar}}{100\%} \times (100\% - 21.5\%) = 284 \text{ bar}$$

F37 seal

The F37 seal was developed especially for use with SAE flanges. Compared to a standard O-Ring the special profile of the F37 seal is ideally adapted to higher pressures and flange surface finish.

The particularly low compression set of the polyurethane compound (e.g. P5008) ensures dimensional stability of the seal over a large temperature range. Its high extrusion resistance prevents gap extrusion even if the flanges "breathe" under

pressure. Due to good abrasion resistance, less preparation is necessary on the surface finish of the sealing area of the flange. The frequently occurring "pumping" phenomenon of O-Rings is prevented by the shape of the F37 seal.

Application area

Sealing for SAE-Flanges

Working pressure: ≤ 600 bar

Working temperature: see table above

Materials

The F37 seal is made of a special polyurethane compound with a hardness of approx. 93 Shore A. In comparison with other polyurethane materials currently available on the market, it excels because of its increased heat resistance, improved performance against hydrolysis and low compression values.

For special requirements (pressure, temperature, flow speed, application in water, HFA-, HFB-fluids etc.), please contact our Consultancy Service, so that suitable materials and/or designs can be recommended.

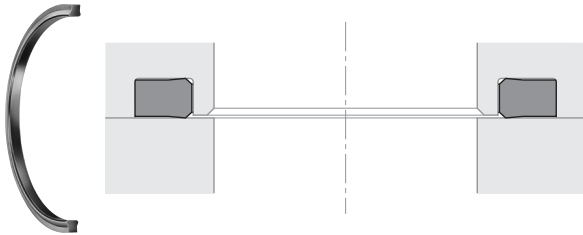

Material designation

Components	Flanges	Seal Carrier, Inserts	Thread adapters	Weld adapter	Soft seal
Material	- Carbon steel, zinc plated Cr(VI)-free, Zinc-Nickel plated or galvanized hot dip zinc - Stainless steel	- Carbon steel, zinc plated Cr(VI)-free or Zinc-Nickel - Stainless steel	- Carbon steel, zinc plated Cr(VI)-free - Stainless steel	- Carbon steel - Stainless steel	- NBR - FKM - PUR

Specification carbon steel for flange components/adapters:

forged or hot rolled steel

C22.3 / C22.8 / ASTM A 105 / S355J2 / C45 and equivalent or higher quality

Specification stainless steel for flange components/adapters:

forged or hot rolled stainless steel

AISI 316 / 316L or 316TI and equivalent or higher quality

1.4462 (S31803, S32205) and equivalent or higher quality

Specification carbon steel for pipes:

cold drawn seamless hydraulic tubes and pipes

E235 / E355 and equivalent or higher quality

Specification stainless steel for pipes:

cold drawn seamless hydraulic tubes and pipes

AISI 316 / 316L or 316TI and equivalent or higher quality

1.4462 (S31803, S32205) and equivalent or higher quality

Technical data

Fluid compatibility

Both metal fitting material and elastomeric seal compound have to be selected according to the fluid used. Standard recommendations for static seals based on experience and sealing compound manufacturers specification. For use of sealing compounds that are used for dynamic seals like rotary fittings or non-return valves, see note at end of table.

Fluid	Fitting material			Sealing material			
	Steel	Stainless steel	Brass	NBR	FKM	EPDM	P5008
Acetone	2	1	1	3	3	1	3
Acetylene	2	1	3	3	3	2	2
Air (oil free)	1	1	1	1	1	1	1
Ammonia liquid	2	1	3	2	3	1	3
Ammonia gas, cold	1	1	3	1	3	1	3
Animal oils (Lard oil)	2	2	2	1	1	2	3
Aral, Vitam BAF	1	1	X	1	1	3	2
Argon	1	1	1	1	1	1	1
Asphalt	3	1	3	2	1	3	2
ASTM-Oil, no. 1	1	1	1	1	1	3	2
ASTM-Oil, no. 2	1	1	1	1	1	3	2
ASTM-Oil, no. 3	1	1	1	1	1	3	2
ASTM-Oil, no. 4	1	1	1	2	1	3	x
ATF oil	1	1	1	1	1	3	1
Automotive brake fluid	1	1	1	3	3	1	2
Benzene	1	1	1	3	1	3	3
Brine (sodium chloride)	X	2	X	1	1	1	3
Butane	1	1	3	1	1	3	2
Carbon bisulphide	1	1	3	3	1	X	3
Carbon dioxide	1	1	1	1	2	1	3
Carbon oxide	1	1	1	1	1	1	1
Castrol, Biotec HVX	1	1	X	1	1	3	3
Chlorine (dry)	3	1	3	3	1	X	x
Compressed air	1	1	1	1	1	1	1
Crude oil	2	1	3	2	1	3	2
Cutting oil	1	1	X	1	3	1	x
DEA, Econa E22	1	1	X	1	X	3	x
DEA, ECONA E46	1	1	X	1	X	3	2
Diesel fuel	1	1	1	1	1	3	2
ECOOL	1	1	X	1	1	X	x
ESSO, Univis 13	1	1	X	1	1	3	x
ESSO, Univis 26	1	1	X	1	1	3	x
ESSO, Univis 32	1	1	X	1	1	3	x
ESSO, Univis 46	1	1	X	1	1	3	x
Ethanol (Ethylalcohol)	1	1	1	1	3	1	3
Ether	1	1	1	3	3	2	x
FINA, Biohydran RS 38	1	1	X	1	1	3	x
Flue gas	3	1	3	3	2	X	x
FRAGOL, Hydrolub 125	1	1	X	1	X	3	x
Freon 11	X	X	1	2	2	3	3
Freon 12	1	3	1	2	1	3	3
Freon 22	3	1	1	3	2	3	3
Gasoline	2	1	1	2	1	3	2
Gas, liquid propane	1	1	1	1	1	3	2
Glycerine	2	1	2	1	1	1	3
Glycol (Ethylenglykol)	1	1	2	1	1	1	3
Heating fuel oil	1	1	1	1	1	3	1
Helium	1	1	1	1	1	1	1
Houghton Safe 1120	1	1	X	3	1	1	3
Houghton Safe 620	1	1	X	1	2	1	3
Hydrochlorid acid	3	2	3	3	1	2	3
Hydrogen	3	1	X	1	1	1	1



Continued on page 23

Fluid compatibility

Fluid	Fitting material			Sealing material			
	Steel	Stainless steel	Brass	NBR	FKM	EPDM	P5008
Hydrogen peroxide	3	1	3	3	1	2	3
Hydrolube	1	1	1	1	1	1	x
Iodine	3	1	3	2	1	2	x
Kerosene	1	1	1	1	1	3	2
Lubricating oil SAE 10, 20, 30, 40 50	1	1	1	1	1	3	1
Methane	1	1	1	1	1	3	3
Methanol	1	1	1	1	3	1	3
MIL-F-8192 (JP-9)	1	1	1	3	1	3	x
MIL-H-5606	1	1	1	1	1	3	x
MIL-H-6083	1	1	1	1	1	3	x
MIL-H-7083	1	1	1	1	2	1	x
MIL-H-8446 (MLO-8515)	1	1	2	2	1	3	x
MIL-L-2104 & 2104B	1	1	1	1	1	3	x
MIL-L-7808	2	1	3	2	1	3	x
Mineral oil	1	1	1	1	1	3	1
Natural gas	1	1	2	1	1	3	2
Natural gas, untreated	3	2 ¹⁾	3	3	3	3	2
Natural mineral oil	1	1	3	2	1	3	1
Neon	3	1	1	1	1	1	1
Nitric acid	3	1	3	3	2	3	3
Nitrogen	1	1	1	1	1	1	1
Oil	1	1	3	1	1	3	2
Oxygen (gas, cold)	3	1	2	3	3	3	1
Ozone	1	1	3	3	1	1	1
Petrolatum	1	1	1	1	1	3	2
Petrolatum oil	1	1	1	1	1	3	3
Phosphoric acid	3	3	1	3	1	2	3
Plantohyd 32 S	1	1	X	1	1	3	x
Plantohyd 40 N	1	1	X	1	1	3	x
Propane	1	1	1	1	1	3	2
R134A	1	1	1	3	3	1	3
Sea Water	3	2	3	1	1	1	2
SHELL, Naturelle HF-E-46	1	1	X	1	1	3	2
SHELL, Tellus Oil DO 32	1	1	X	1	1	3	2
Silicone oil	1	1	X	1	1	1	1
Skydrol 500	1	1	3	3	3	1	3
Skydrol 7000	1	1	3	3	2	1	3
Soap solutions	3	1	3	1	1	1	2
Steam	2	1	2	3	3	1	3
Stoddard solvent	1	1	2	1	1	3	1
Sulphur dioxide	3	1	3	3	3	1	3
Sulphuric acid	3	2	3	3	1	3	3
Toluol	1	1	1	3	2	3	3
Transmission fluid	1	1	1	1	1	3	2
Trichlorethane	2	1	X	3	1	3	3
Turpentine	2	1	3	1	1	3	3
Water	2	1	1 ²⁾	1	2	1	2
Xylol	1	1	1	3	1	3	3

up to 60°C

up to 60°C

Applicability:

1 = satisfactory

2 = fair

3 = not recommended

X = insufficient data

NBR = e.g. Perbunan (registered trademark of Bayer)

FKM

¹⁾ Untreated natural gas requires stainless steel with reduced material hardness.

²⁾ Brass is resistant against crack under normal circumstances. If overloaded (e.g. by overassembly) the resistance especially against ammoniac and nitric derivatives can be negatively influenced. This might cause the defect of the connection.

This fluid compatibility chart is only applicable on so called "static seals", such as O-rings and profile sealing rings (e.g. ED-seal, DOZ-seal) in tube fitting and flange systems.

For fluid compatibility data of valves, rotary fittings or other multi-function components please review the relevant product pages.



ENGINEERING YOUR SUCCESS.

Pressure reductions and temperatures for ball valves

Body, adapters, stem and ball materials	Pressure reduction of permissible operating temperatures TB in °C													
	-60	-50	-40	-30	-20	-10	0	+20	+80	+100	+120	+130	+150	+200
Free-Cutting steel, not suitable for gas applications!	0%													
Low-Alloy Steel	-25%					0%								
Stainless steel	0%										-11%			
Duplex Steel						0%					-20%			

Ball seat material	Pressure reduction of permissible operating temperatures TB in °C													
	-60	-50	-40	-30	-20	-10	0	+20	+80	+100	+120	+130	+150	+200
POM	0%													
Cast Iron GG25	0%													

Stem and adapter sealing materials	Pressure reduction of permissible operating temperatures TB in °C													
	-60	-50	-40	-30	-20	-10	0	+20	+80	+100	+120	+130	+150	+200
Acrylonitrile-butadienerubber (NBR, Buna N)				0%										
Low-temp NBR Compound	0%													
FKM					0%									
Low-temp FKM Compound			0%											
EPDM			0%											

	Permitted operating temperature
	Temperature not permitted

A test pressure of 1.5 x PN applies to all ball valves in accordance with DIN 3230 T5 and ISO 5108 for body.

1.1 x PN applies to ball seats.

The nominal pressure specifies the admissible working pressure at 20°C. Please consider the pressure reduction at higher temperature.

The safety factor for burst pressure tests is a minimum of 2.4 times the nominal pressure.

$P_{Burst} = 2.4 \times PN$

Leakage tests are done acc. DIN EN 12266 leakage rate A (No visually noticeable leakage during the duration of the test with fluid or air).

For other materials than listed, please contact Parker HPCE.



Installation F37 Flange system

Current installation guide:

www.parker.com/hpce ↴

Resources ↴

Installation Guides & Manuals

ENGINEERING YOUR SUCCESS.

Notes

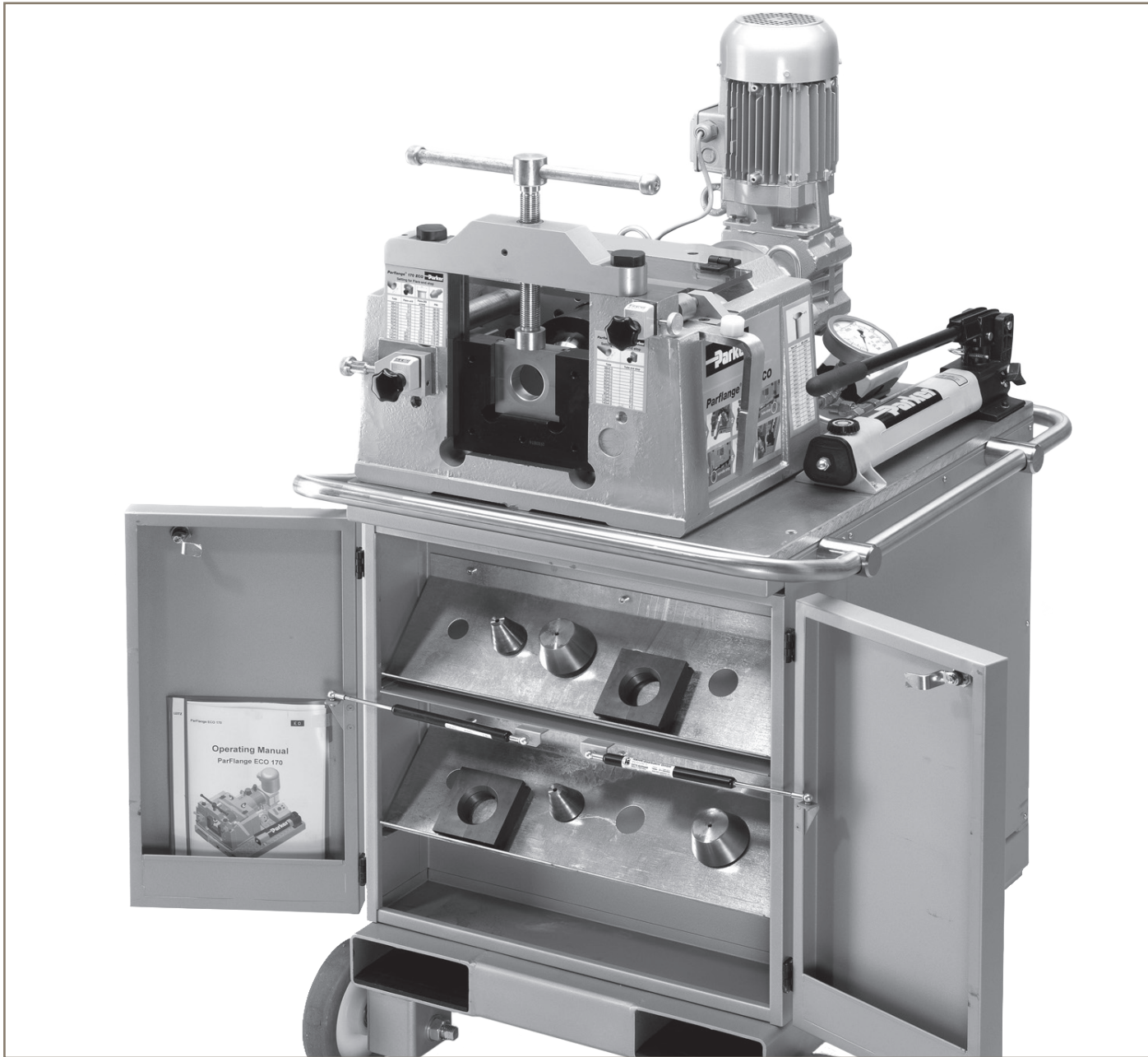

Machines, tooling and equipment

ENGINEERING YOUR SUCCESS.

Parflange® 170

Workshop machine for F37 flange connections

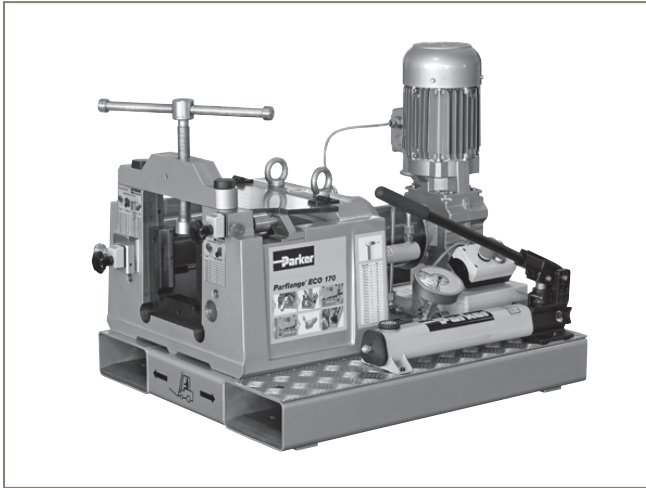

Parflange® 170 ECO for workbench

The Parflange® 170 ECO is a compact workshop machine for 37° flaring of tubes for flange connections.

The orbital tube flaring is achieved by a rotating flaring unit, powered by an electro-mechanical drive. Two hydraulic cylinders operated by a hand pump generate the axial feed movement. Gas springs move the flaring unit back after the valve on the hand pump is opened. The tubes are mechanically clamped between a set of dies. The machine features an adjustable tube stop for tube positioning (Tube Stop), and an adjustable stop for the tube depth to be flared (Spindle Stop).

The machine is used to form tube ends by means of a rotational action. It is designed as a workshop machine for installations of tube connections.

The machine is available in 2 versions:

- Parflange® 170 ECO for use on work bench and
- WorkCenter Parflange® 170 WCM which is mounted on a movable tool cabinet

Parflange® machines are delivered ready for use. Tools have to be ordered separately. Clamping die sets and flanging pins are available for common tube sizes. The machine can be moved by crane or forklift.

Applications

- The F37 system is an alternative to conventional welding of flanges in shipbuilding, oil & gas exploration and similar industries
- Workshop use, project work, plant maintenance, on-site assembly
- Not recommended for mass production



Parflange® 170 WCM WorkCenter

Specifications

Purpose	37° flaring for Parker F37 flange connection
Process	Tube forming by orbital flaring process
Design	On-site and workshop machine for individual tube manufacturing
Models	<ul style="list-style-type: none"> ● Parflange® 170 ECO for use on work bench, easy to transport, optimal to use on site ● WorkCenter Parflange® 170 WCM, mounted on a movable tool cabinet, optimal to use in a production hall
Operation	Manual tube clamping Electrically driven flaring unit Manual feed by hand-pump
Tube diameter	16 mm – 168.3 mm O.D.
Maximum capacity	168.3 x 2.77 mm
Tube material	Steel and stainless steel
Cycle time	1 – 2 minutes flaring time 3 – 5 minutes total cycle time
Economic production quantity	Up to 50 assemblies per day
Tools	Flanging pin BF37... Clamping die set MF37... Die frames required for small to medium sizes
Tool lubrication	manual
Forming lubricant for pin	LUBSS
Machine dimensions (L x W x H)	Parflange® 170 ECO: 850 x 680 x 675 mm Parflange® 170 WCM: 880 x 810 x 1470 mm
Weight	Parflange® 170 ECO: approx. 350 kg Parflange® 170 WCM: approx. 460 kg
Nominal voltage	400 V/3Ph/50 Hz/3A/1.1 KW
Connecting cable	3m/CEE 16A
Sound pressure level	Less than 70 dB (A)

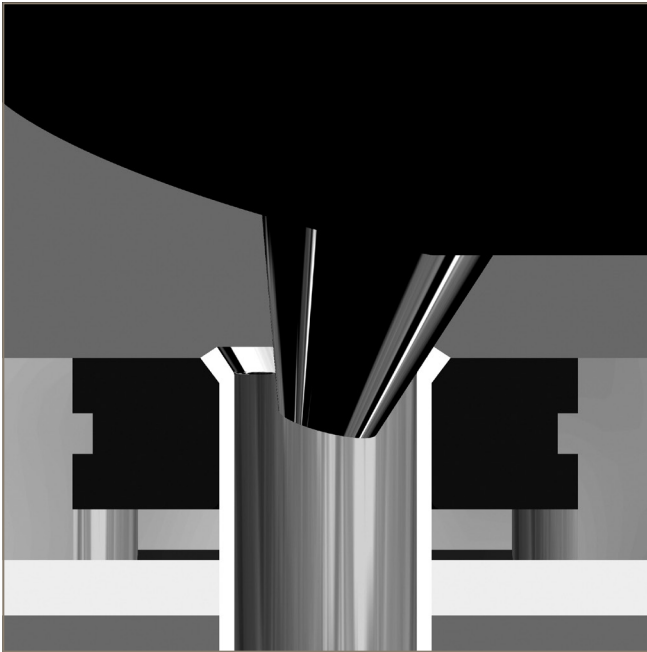

Superior sealing surface is achieved by orbital flaring

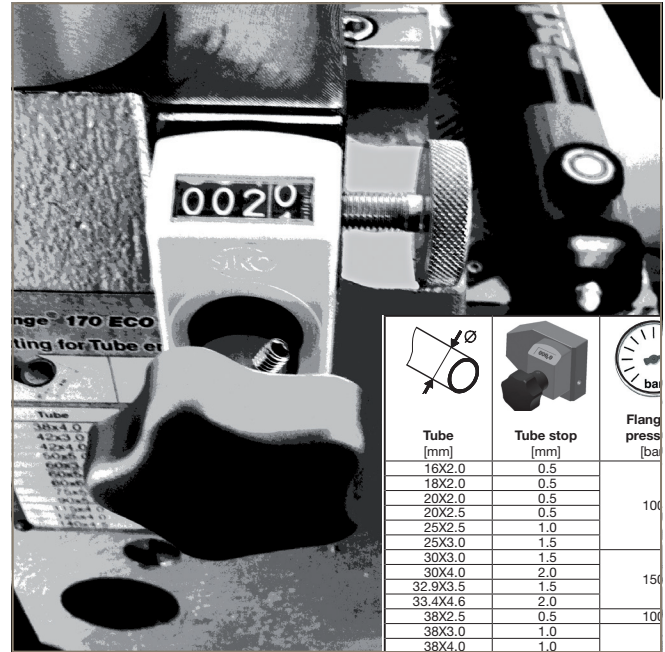

Consistent flaring result is achieved by setting of Tube Stop and Spindle Stop

Features, advantages and benefits of Parflange® 170 ECO

- Cost saving** – Compared to welding or brazing, orbital flaring is much less time consuming. Special tube preparation and finishing are not necessary. Flaring uses only a fraction of the energy needed for brazing or welding.
- Zinc plated tubing** – The Parflange® process allows the use of zinc plated tubing. The cost for cleaning, post process plating or painting is saved.
- Superior sealing performance** – The orbital flaring process achieves a sealing surface of superior surface quality and mechanical strength.
- Process/Product concept** – Parflange® machines are especially designed to match Parker F37 flange standards. Machines, tools and products are fine-tuned for reliable performance.
- Workshop use** – The rigid machine design allows project work in on site piping workshops.
- Short clamping length** – Clamping dies for 37° flaring are optimized for minimum straight tube length.
- Easy to use** – All operational devices are obvious so that machine operation is intuitive.
- Quality** – Consistent quality results are achieved by recommended values for machine setting.
- Constant flare diameter** – The diameter of the 37° flare is given by the tool contour and the Tube Stop adjustment. A chart on the machine indicates recommended Tube Stop setting.
- Prevention of over-flaring** – The shape of the 37° flare is given by the tool contour and the Spindle Stop adjustment. This prevents difficulties to fit the insert into the flare.
- Flexible** – Different tube material and quality might require special setting of Tube Stop, Spindle Stop, flanging feed and flanging force. For best results, these parameters can be manually adjusted based on operators experience.
- Clean** – The Parflange® process is environmentally clean and safe. As no heat or chemicals are used, hazards from fumes or heat do not occur.
- Perfect for on site work** – The machine has special attachments for transportation by fork lift and crane. The wide base provides a safe stand. This is particularly useful for on site pipe installation in shipyards or in oil and gas exploration.
- Ready to go** – The Parflange® 170 ECO is delivered including all necessary details like electrical plug, operator manual, declaration of CE-conformity, short instruction pictograms on machine housing and dimensional charts for tube preparation.
- Parflange® 170 WCM** – This model is mounted on a robust tool cabinet with wheels. It is easy to move and perfect for flexible workshop use.

Tool selection

Workshop machine for F37 flange connections

Ordering

Type	Order code
Parflange® 170 Basic machine	
Ready to use, including operation manual, filled with hydraulic oil, without tools	
Basic machine for workbench use, 400V, 50Hz	170EU400VECO
WorkCenter with tool cabinet, 400V, 50Hz	170EU400VWCM
Promotion leaflet 4162/UK	via Parker catalogue service EMDC
Tool lubricant qty: 1 L	LUBSS

Parflange® machines are shipped in special containers which should be kept for future transportation to avoid damage.

Clamping die frame small/large		Clamping die set "MF"	Extended clamping die set "MF" for large tube wall thickness	Flanging pin "BF"
Tube O.D. mm	Order code Clamping die frame	Order code Clamping die set	Order code Extended clamping die set	Order code Flanging pin
16.0	MF37/FRAME20-60	MF37-16		BF37-6/42
20.0		MF37-20		
25.0		MF37-25		
26.7		MF37-26.7		
30.0		MF37-30		
32.9		MF37-32.9		
33.4		MF37-33.4		
38.0		MF37-38		BF37-38/60
42.0		MF37-42		
48.3		MF37-48.3		
50.0		MF37-50		BF37-60/75
60.0		MF37-60		
60.3		MF37-60.3		
65.0		MF37/FRAME73-90		MF37-65 E
73.0	MF37-73		MF37-73E for Tube 73X7	
75.0	MF37-75			
88.9	MF37-88.9			
90.0	MF37-90			
90.9			MF37-90E	BF37-90PREFLARE and BF37-75/90
100.0	no frame required	MF37-100		BF37-100
114.3		MF37-114.3	MF37-114.3E for Tube 114.3X6.02	BF37-115/140
115.0		MF37-115		
125.0		MF37-125		
139.7		MF37-139.7		
140.0		MF37-140		BF37-141/165
141.3		MF37-141.3		
165.0		MF37-165		
168.3		MF37-168.3		

tools for scheduled pipes on request

Tool lifetime

Assembly tools are subject of wear and must be regularly cleaned and checked.

Worn out tools can cause dangerous assembly failures and must be replaced in time.

Maximum lifetime can be achieved by following factors:

- Regular cleaning and checking
- Clean and corrosion-protected storage
- Proper de-burring and cleaning of tube end
- Proper tool selection and operation
- Use of specified lubricant



Assembly machines

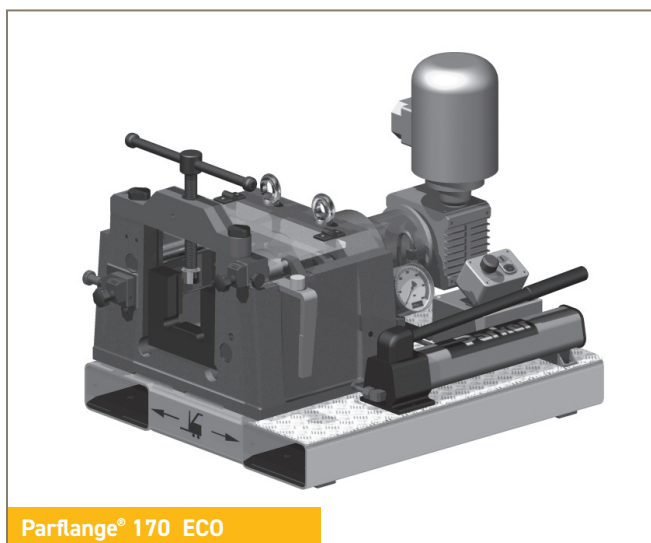

Parflange® 170 ECO

Parflange® 170 ECO

The Parflange® 170 is a simple flaring machine for Parker F37 connections. By using the Parflange® process, it achieves an excellent sealing surface and a high-strength tube connection.

The equipment is very robust and easy to use. It saves time and effort compared to conventional welding of flange connections.

Parflange® 170 WCM Workcenter is ideal for workshop use. The 170 ECO is ideal for onsite installation.

- 37° flaring of: F37 flange connection
- Tube-OD: 16 - 168.3 mm
- Total cycle time: 30 - 60 sec.
- Economic production quantity: max. 50 assemblies per day
- Dimensions (L x W x H): ECO: 850 x 680 x 675
- Weight: 360 kg
- Power supply: 400 V 3-phase 50 Hz 1,1 kW

Catalogue: 4100



Parflange® 170 WCM

Parflange® 170 WCM

The Parflange® 170 WCM is a flaring Work Centre for Parker F37 connections. By using the Parflange process, it achieves an excellent sealing surface and a high-strength tube connection.

The machine is mounted on a robust tool cabinet with wheels. The EO2-FORM F3 represents a complete tube forming WorkCenter.

The Parflange 170 WCM is ideal for workshop use and on-site installation.

- 37° flaring of: F37 flange connection
- Assembly method: Orbital forming
- Tube-OD: 16 - 168.3 mm
- Total cycle time: 30 - 60 sec.
- Economic production quantity: max. 150 assemblies per day
- Dimensions (L x W x H): 880 x 810 x 1470

- Weight: 460 kg
- Power supply: 400 V 3-phase 50 Hz

Catalogue: 4162

Bulletin: 4165

Lubricants

EO-NIROMONT lubricant for fitting assembly

EO-NIROMONT lubricant for flaring and forming tools

EO-NIROMONT are high performance lubricants specifically designed for the assembly of tube connections. They facilitate tightening using a low-torque when assembling joints by hand. In machine assembly, the use of EO-NIROMONT ensures that maximum tool-life is achieved. In forming processes, such as Parflange® or EO2-FORM, smooth and error-free sealing surfaces can be produced. Special additives prevent cold welding when working with stainless steel.

As opposed to when using Parker high performance lubricants, experience shows that the use of standard commercially available lubricants tend to lead to problems such as cold welding of forming tools, particularly when processing stainless steel tube. Parker high performance lubricants – EO-NIROMONT – are offered in different containers and viscosities so that you can purchase the appropriate product in a suitable container to meet your needs:

Liquid lubricant, plastic bottle (item: EONIROMONTFLUOSSX)

Parker high performance lubricant for the lubrication of threads, progressive rings and for all cold forming processes like Parflange® or EO2-FORM. The handy plastic bottle means that it can be applied directly where the lubrication is needed. EO-NIROMONT liquid should always be available at every assembly point where hydraulic connections are being made.

Liquid lubricant, refill package (Item: LUBSS)

Parker high performance lubricant for all cold forming processes like Parflange® or EO2-FORM. Its viscosity means that it is for use in automatic lubrication devices installed in Parflange machines. Absolutely essential for mechanical cold forming of stainless steel tubes.

Paste lubricant, tin (Item: EONIROMONTPASTX)

Parker high performance lubricant for the lubrication of the threads of the pre-assembly tool VOMO. The paste is economical and provides durable thread lubrication. Not suited for use with forming tools, as dust and swarf will stick to it.

Liquid lubricant in a brush-in-cap can (item: EONIROMONTAPPLICATOR)

Thanks to a brush built into the screw cap, the practical EO-NIROMONT APPLICATOR enables the Parker high-performance lubricant to be applied accurately on the component. The plastic bottle can be used to refill the brush-in-cap can practically.

Features, advantages and benefits of NIROMONT lubricant:

1. **Highly effective** – EO-NIROMONT dramatically reduces assembly effort. This helps to prevent fitting failure resulting from insufficient assembly.
2. **Cost saving** – Tools in assembly machines will last much longer, resulting in high-quality tube forming with excellent sealing surface.
3. **No cold welding** – Cold welding of stainless steel threads is impossible when EO-Niromont is properly applied.
4. **Liquid** – Penetrates even small gaps.
5. **Paste** – Stays in place for a while. Ideal for application on pre-assembly tools.
6. **Compatible** – EO-NIROMONT and LUBSS do not effect fitting surfaces or seal materials.

Ordering

Type	Order code
EO-NIROMONT Assembly lubricant paste (100 g e)	EONIROMONTPASTX
EO-NIROMONT Assembly lubricant liquid (250 cc)	EONIROMONTFLUOSSX
EO-NIROMONT Liquid lubricant in a brush-in-cap can (250 cc)	EONIROMONTAPPLICATOR
EO-NIROMONT Forming tool lubricant refill (1 L)	LUBSS



EO-NIROMONT



EO-NIROMONT APPLICATOR



LUBSS

Assembly machines

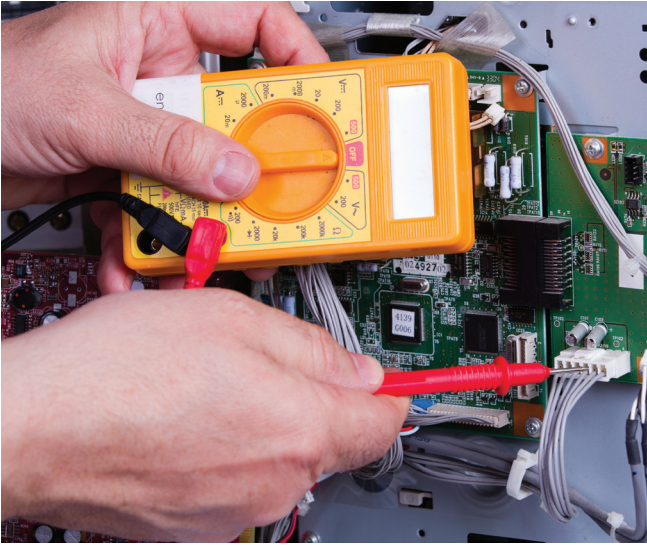

Technical support for Parker machines

HPCE machine service procedures ensure that reliable machine function and fitting performance is achieved when using genuine Parker assembly equipment.

All machines come with detailed operating manuals. Parker distributors and sales representatives are trained to give advice on operation and applications. Experienced application engineers at HPCE are available when it comes to special application of HPCE assembly equipment.

In case of machine malfunction, spare machines can be provided on short notice so that production can continue. In the meantime, damaged machinery is checked and repaired at the HPCE machine repair facility. Well trained and experienced engineers take personal care that the machines return properly repaired and tested.

HPCE also offers a machine maintenance and calibration service. Standard spare parts like oil filters can be ordered.

Notes

ISO 6162-1

F37 seal

on

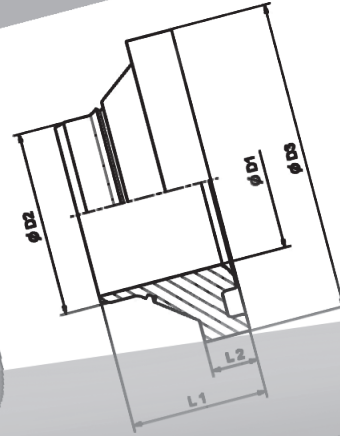

How to order

Selecting

1. All flange sizes are clearly listed in the catalogue.
2. Open the catalogue to the page containing detailed information of your choice.
3. Select the correct size based on the dimensions on the right.

D1	D2	D3	L1	L2	Weight (Steel) kg/1 piece	F37 seal Order code	O-Ring Order code	Insert incl. F37 seal + O-Ring Order code
25.0	32.8	45.0	22.0	7.0	0.11	F37S16X	OR34X1.0X	IN16-38X2.5TFVCF
25.0	31.8	45.0	22.0	7.0	0.10	F37S16X	OR34X1.0X	IN16-38X3.0TFVCF
25.0	29.8	45.0	22.0	7.0	0.10	F37S16X	OR30X1.0X	IN16-38X4.0TFVCF
25.0	27.8	45.0	21.0	7.0	0.09	F37S16X	OR28X1.0X	IN16-38X5.0TFVCF
29.5	31.8	50.0	22.0	7.5	0.10	F37S20X	OR34X1.0X	IN16-38X6.0TFVCF
27.0	29.8	50.0	22.0	7.5	0.11	F37S20X	OR30X1.0X	
25.5	27.8	50.0	21.0	7.5	0.10	F37S20X	OR28X1.0X	
31.5	35.8	50.0	22.0	7.5	0.11	F37S20X	OR37.8	
31.5	33.8	50.0	22.0	7.5	0.10	F37S20X	OR34	
35.8	35.8	60.0	25.5	10.0	0.19	F37S24X	OR37	
33.8	33.8	60.0	25.5	10.0	0.19	F37S24X	OR34	
31.5	43.8	60.0	25.5	10.0	0.20	F37S24X	OR44	
36.0	39.8	60.0	27.0	10.0	0.20	F37S24X	OR41	
36.0	37.8	60.0	27.0	10.0	0.20	F37S24X	OR41	
35.0	43.8	70.0	24.0	10.0	0.22	F37S32X	OR44	
41.5	39.8	70.0	26.5	10.0	0.24	F37S32X	OR41	
37.5	37.8	70.0	27.0	10.0	0.27	F37S32X	OR41	
35.0	43.8	70.0	27.0	10.0	0.27	F37S32X	OR41	
37.5	37.8	70.0	27.0	10.0	0.24	F37S32X	OR41	
35.0	53.8	70.0	26.5	10.0	0.23	F37S40X	OR41	
					3.50	F37S40X	OR41	



Step
Sele
Now
fac
to
Th
to
4

Ordering information/Nomenclature

Parflange® F37 Code Key

Flare Flange Example:

F37-3	20	-42X3.0	TFV	CF
--------------	-----------	----------------	------------	-----------

Part code		
Flange Type	Flange code	Footprint
F37	1	ISO 6162-1 SAE 1000
F37	3	ISO 6162-1 SAE 3000
F37	6	ISO 6162-2 SAE 6000
F37	4	ISO 6164

Size Code												
8	12	16	20	24	32	40	48	64	80	96	128	160
1/2"	3/4"	1"	1 1/4"	1 1/2"	2"	2 1/2"	3"	4"	5"	6"	8"	10"

Pipe size and Insert Code	
42X3.0	/ Pipe O. D. X wall thickness (mm)

Flange connection/Sealing system	
TFV	Tube to port connection, F37 seal version
TFB	Tube to port connection, Bonded seal version
TT	Tube to tube connection
TF	Tube to flange connection, Flat face version

Material and coating	
CF	Steel, Cr(VI)-free
CFTZN	Steel, Hot dip galvanized (only Flanges)
SS	Stainless Steel

Bolts and nuts are not components of the complete Part code

Combination examples

	Complete Part No.	Component	No.	Code	Material
Standard combination Steel CF	F37-320-42X3.0TFVCF Tube to port (F37 seal) 1 1/4" SAE 3000 Flare Flange	Flare Flange	1	F37-320-CFX	Steel, Cr(VI)-free
		Insert incl. O-Ring and F37 Seal	1	IN20-42X3.0TFVCF	Steel, Cr(VI)-free
		O-Ring	1	OR37.82X1.78X	NBR, 90° shore
		F37 Seal	1	F37S20X	PUR
Stainless Steel	F37-620-38X4.0TFVSS Tube to port (F37 seal) 1 1/4" SAE 6000 Flare Flange, 38 mm OD tube Jump size	Flare Flange	1	F37-620/38-SSX	Stainless Steel
		Insert incl. O-Ring and F37 seal	1	IN20-38X4.0TFVSS	Stainless Steel
		O-Ring	1	OR30X1.0X	NBR, 90° Shore
		F37 seal	1	F37S20X	PUR
Hot. dip galv. Flange and Stainless Steel Insert	F37-620-38X4.0TFVSSTZN Tube to port (F37 seal) 1 1/4" SAE 6000 Flare Flange, 38 mm OD tube Jump size	Flare Flange	1	F37-620/38-TZNX	Hot dip galv.
		Insert incl. O-Ring and F37 seal	1	IN20-38X4.0TFVSS	Stainless steel
		O-Ring	1	OR30X1.0X	NBR, 90° Shore
		F37 seal	1	F37S20X	PUR

Before ordering components please check requirements from the classification companies.



Parflange® Retaining Ring Code Key

Retaining Ring Examples:

R-1	32	WA	-60.3X2.9	S
------------	-----------	-----------	------------------	----------

Part code	Flange Type	Flange code	Footprint
R		1	ISO 6162-1 SAE 1000
R		3	ISO 6162-1 SAE 3000
R		6	ISO 6162-2 SAE 6000
R		4	ISO 6164 4 Bolt Flange
R		8	8-12 Bolt Flange*

Size Code													
8	12	16	20	24	32	40	48	64	72	80	96	128	160
1/2"	3/4"	1"	1 1/4"	1 1/2"	2"	2 1/2"	3"	4"	4 1/2"	5"	6"	8"	10"

Weld adapter

Pipe size and Insert Code
60.3X2.9/Pipe O. D. X wall thickness (mm)

Material and coating	
S	Weld Adapter O-Ring Sealing by SAE 1000 (other footprints bonded seal), Steel
FS	Weld Adapter Flat, Steel
SS	Weld Adapter O-Ring sealing, Stainless Steel
FSS	Weld Adapter Flat, Stainless Steel
SSTZN	Weld Adapter O-Ring sealing, Stainless Steel and hot dip galv. Flange
FSSTZN	Weld Adapter Flat, Stainless Steel and hot dip galv. Flange

*Round flange design; Footprint deviating from ISO-/SAE-Standards
Bolts and nuts are not components of the complete Part code

Combination examples

	Complete Part No.	Component	No.	Code	Material
Standard combination Steel CF	R-132WA-60.3X2.9S SAE 1000 Retaining Ring Weld Adapter	Retaining Ring Flange	1	R-132-CFX	Steel, Cr(VI)-free
		Retaining Ring		R32X	Stainless Steel
		Weld Adapter body O-Ring	1	WA132-60.3X2.9S OR56.75X3.53X	Steel, Cr(VI)-free NBR, 90° Shore
Stainless Steel	R-620WA-38X4.0SS SAE 6000 Retaining Ring Weld Adapter	Retaining Ring Flange	1	R-620-SSX	Stainless Steel
		Retaining Ring	1	R20X	Stainless Steel
		Weld Adapter body	1	WA20-38X4.0SSX	Stainless Steel
		Bonded seal	1	BS20SSNX	Stainless Steel/ NBR, 90° Shore
Stainless Steel	R-PSC8128-250X25VSS SAE 6000 8" Retaining Ring and Pipe seal carrier, 250 mm OD tube	Retaining Ring Flange	1	R-8128-SSX	Stainless Steel
		Retaining Ring	1	R128X	Stainless Steel
		Pipe seal carrier	1	PSC128-250X25VSSX	Stainless Steel
		F37 seal	1	F37RS128X	PUR

Before ordering components please check requirements from the classification companies.

ENGINEERING YOUR SUCCESS.

Notes











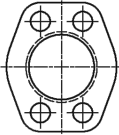

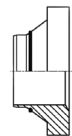
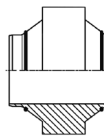
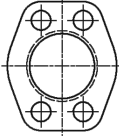
SAE 1000 System

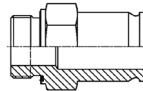
50 – 70 bar

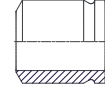
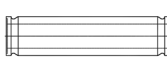
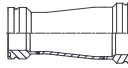
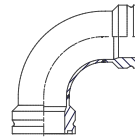
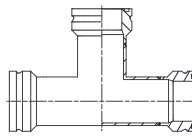
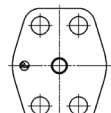
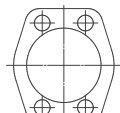
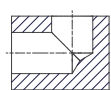
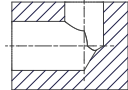
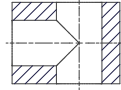
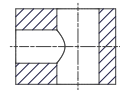
ENGINEERING YOUR SUCCESS.

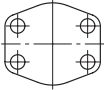
Programme overview SAE 1000/ISO 6162-1 footprint

Parflange® F37 connection parts	Flanges  F37 – p.39		
	Inserts    TFV – p.41 TF – p.42 TT – p.43		
	Retaining ring connection parts		
Retaining ring connection parts	Flanges    R – p.40 R-Ring – p.44 R – p.40		
	Male / Female   MTF-R – p.45 FTF-R – p.46	Weld   WA – p.47 WA-F – p.48	
	Tube to Tube     BF – p.49 RF – p.50 LF – p.51 TF – p.52		
	SAE connection parts	Blind Flanges   BFV – p.53 CPML – p.54	Blocks see SAE 3000     LB – p.85 LBR – p.86 TB – p.87 TBR – p.88
		Seals Adapter Bolts  p.55	 AP – p.56
Ball valves	 p. 57/58		

F37 – Flare flange | SAE 1000/ISO 6162-1 footprint

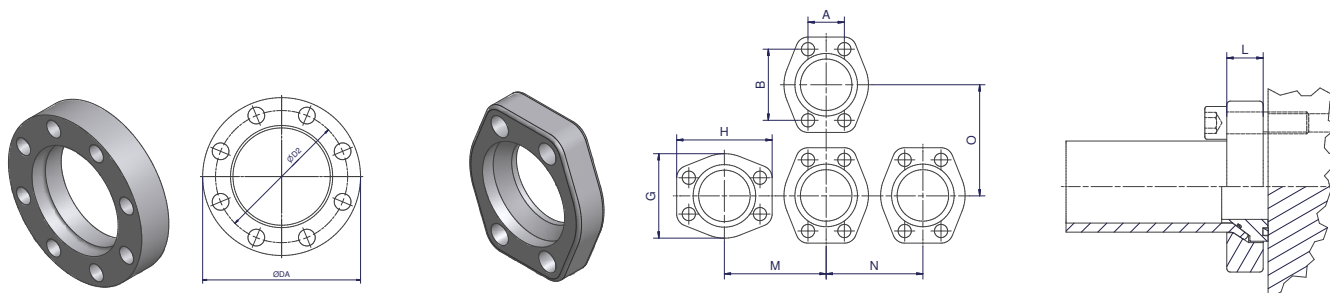

Parflange F37 flange dimensions

Size Inch	Flange Order Code	A	B	G	H	M	N	O	L	Bolts/pc.	Weight (Steel) kg/1 piece	W.P. bar
1 1/2	F37-124-CFX	35.7	69.9	83	94	93	87	99	20	4	0.52	70
2	F37-132-CFX	42.9	77.8	97	102	104	102	107	25	4	0.83	70
2 1/2	F37-140-CFX	50.8	88.9	109	114	117	114	120	30	4	1.16	70
3	F37-148-CFX	61.9	106.4	131	135	138	136	141	30	4	1.57	70
3 1/2	F37-156-CFX	69.9	120.7	140	152	151	145	158	30	4	1.99	70
4	F37-164-CFX	77.8	130.2	152	162	162	157	168	39	4	2.69	70
5	F37-180-CFX	92.1	152.4	181	184	188	186	190	39	4	3.24	50
		D2	DA									
6	F37-196-CFX	208.0	235.0						39	6	5.60	50
8	F37-1128-CFX	275.0	318.0						39	8	10.51	50
10	F37-1160-CFX	345.0	410.0						50	8	25.35	50

Pressure rates related to flanges. For all sizes also threaded flanges available (...T-CFX).

Please change suffixes according to material/surface required

Order code suffixes			
Material	Suffix surface and material	Example	Comments
Steel, zinc plated, Cr(VI)-free	CF	F37-124-CFX	
Stainless steel	SS	F37-124-SSX	
Galvanized hot dip zinc	TZN (Not for threaded flanges available)	F37-124-TZNX	on request

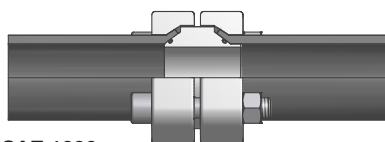

Part combination flaring SAE 1000

Flange Pressure (bar)	Size Inch	Pipe Size	Flange 1000 SAE ISO 6162-1 footprint	Insert*
70	1 1/2	50X3.0	F37-124-CFX	IN24-50X3.0T...
	2	60X3.0	F37-132-CFX	IN32-60X3.0T...
	2 1/2	75X3.0	F37-140-CFX	IN40-75X3.0T...
	3	88.9X3.05	F37-14888.9-CFX	IN48-88.9X3.05T...
	3	90X3.5	F37-148-CFX	IN48-90X3.5T...
	3 1/2	100X4.0	F37-156-CFX	IN56-100X4.0T...
50	4	115X4.0	F37-164-CFX	IN64-115X4.0T...
	5	140X4.5	F37-180-CFX	IN80-140X4.5T...
	6	165X5.0	F37-196-CFX	IN96-165X5.0T...
	8	220X6.0	F37-1128-CFX	IN128-220X6.0T...
	10	273X6.0	F37-1160-CFX	IN160-273X6.0T...

Select the complete version:

- * ...FVCF Seal version
- ...TCF Tube to Tube version
- ...FCF Flat Face version

Other sizes on request. Bolts and nuts are not included in complete part numbers. For recommended bolts and nuts see page 55.

R – Retaining ring flange | SAE 1000/ISO 6162-1 footprint

SAE 1000/ISO 6162-1 footprint

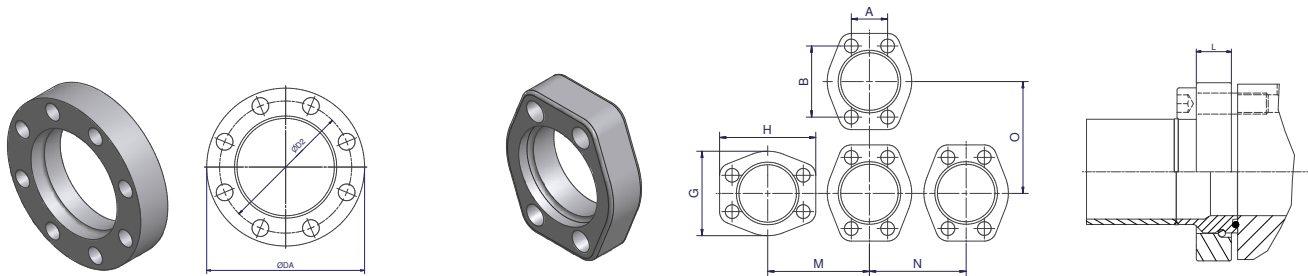

Retaining Ring Flange dimensions

Size Inch	Flange Order code	A	B	G	H	M	N	O	L	Bolts/pc.	Weight (Steel) kg/1 piece	W.P. bar
1 1/2	R-124-CFX	35.7	69.9	83	94	93	87	99	20	4	0.46	70
2	R-132-CFX	42.9	77.8	97	102	104	102	107	20	4	0.57	70
2 1/2	R-140-CFX	50.8	88.9	109	114	117	114	120	20	4	0.70	70
3	R-148-CFX	61.9	106.4	131	135	138	136	141	25	4	1.18	70
3 1/2	R-156-CFX	69.9	120.7	140	152	151	145	158	29	4	1.47	70
4	R-164-CFX	77.8	130.2	152	162	162	157	168	30	4	1.74	70
5	R-180-CFX	92.1	152.4	181	184	188	186	190	39	4	2.81	70
		D2	DA									
6	R-196-CFX	208.0	235.0						39	6	4.96	70
8	R-1128-CFX	275.0	318.0						38	8	8.95	50
10	R-1160-CFX	345.0	410.0						50	8	23.29	50

Pressure rates related to flanges. For all sizes also threaded flanges available (...T-CFX).

Please change suffixes according to material/surface required

Order code suffixes		
Material	Suffix surface and material	Example
Steel, zinc plated, Cr(VI)-free	CF	R-124-CFX
Stainless steel	SS	R-124-SSX
Galvanized hot dip zinc	TZN (Not for threaded flanges available)	R-124-TZN

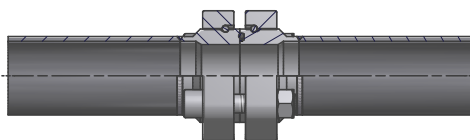

Part combination retaining ring SAE 1000 (O-Ring) connection

Flange pressure (bar)	Size Inch	Flange	Retaining Ring
70	1 1/2	R-124-CFX	R124X
	2	R-132-CFX	R132X
	2 1/2	R-140-CFX	R140X
	3	R-148-CFX	R148X
	3 1/2	R-156-CFX	R156X
	4	R-164-CFX	R164X
	5	R-180-CFX	R180X
50	6	R-196-CFX	R196X
	8	R-1128-CFX	R1128X
	10	R-1160-CFX	R1160X

Other sizes on request. Bolts and nuts are not included in complete part numbers. For recommended bolts and nuts see page 55.



TFV - Flare flange connection

Tube to port connection

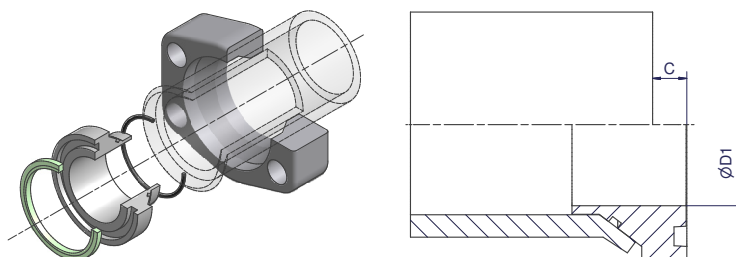

Size Inch	Tube	Flange incl. Insert F37 Seal + O-Ring Order code	D1	C	Insert incl. F37 Seal + O-Ring Order code	O-Ring Tube Side Order code	F37 Seal Port Side Order code	Weight (Steel) kg/1 kit
1 1/2	50X3.0	F37-124-50X3.0TFVCF	36.0	11	IN24-50X3.0TFVCF	OR44.17X1.78X	F37S24X	0.72
2	60X3.0	F37-132-60X3.0TFVCF	46.0	12	IN32-60X3.0TFVCF	OR53.7X1.78X	F37S32X	1.10
2 1/2	75X3.0	F37-140-75X3.0TFVCF	60.0	10	IN40-75X3.0TFVCF	OR69.57X1.78X	F37S40X	1.46
3	90X3.5	F37-148-90X3.5TFVCF	72.0	15	IN48-90X3.5TFVCF	OR82.27X1.78X	F37S48X	2.17
3 1/2	100x4.0	F37-156-100X4.0TFVCF	88.6	15	IN56-100X4.0TFVCF	OR94.97X1.78X	F37S56X	2.60
4	115X4.0	F37-164-115X4.0TFVCF	90.0	14	IN64-115X4.0TFVCF	OR110X2X	F37S64X	3.53
5	140X4.5	F37-180-140X4.5TFVCF	122.0	15	IN80-140X4.5TFVCF	OR129.77X3.53X	F37S80X	4.09
6	165X5.0	F37-196-165X5.0TFVCF	150.8	17	IN96-165X5.0TFVCF	OR158.42X2.26X	F37S196X	6.98
8	220X6.0	F37-1128-220X6.0TFVCF	203.3	16	IN128-220X6.0TFVCF	OR209.22X2.62X	F37S1128X	12.66
10	273X6.0	F37-1160-273X6.0TFVCF	256.2	17	IN160-273X6.0TFVCF	OR262.34X3.53X	F37S1160X	28.78

Other sizes on request.

Please change suffixes according to material/surface required

Order code suffixes		
Material	Suffix surface and material	Example
Steel, zinc plated, Cr(VI)-free	CF	F37-124-50X3.0TFVCF
Stainless steel	SS	F37-124-50X3.0TFVSS

TF – Flare flange connection

Tube to port connection, flat face

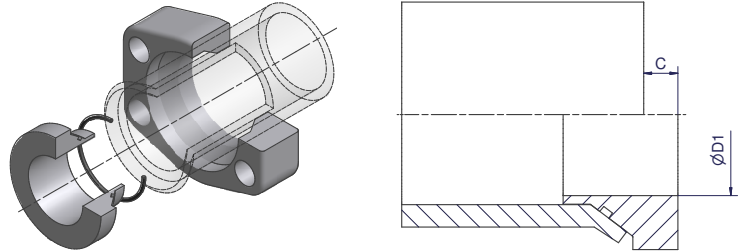

Size Inch	Tube	Flange incl. Insert + O-Ring Order code	D1	C	Insert incl. O-Ring Order code	O-Ring Tube Side Order code	Weight (Steel) kg/1 kit
1 1/2	50X3.0	F37-124-50X3.0TFCF	36.0	11	IN24-50X3.0TFCF	OR44.17X1.78X	0.72
2	60X3.0	F37-132-60X3.0TFCF	46.0	12	IN32-60X3.0TFCF	OR53.7X1.78X	1.10
2 1/2	75X3.0	F37-140-75X3.0TFCF	60.0	10	IN40-75X3.0TFCF	OR69.57X1.78X	1.46
3	90X3.5	F37-148-90X3.5TFCF	72.0	15	IN48-90X3.5TFCF	OR82.27X1.78X	2.17
3 1/2	100X4.0	F37-156-100X4.0TFCF	88.6	15	IN56-100X4.0TFCF	OR94.97X1.78X	2.60
4	115X4.0	F37-164-115X4.0TFCF	90.0	14	IN64-115X4.0TFCF	OR110X2X	3.60
5	140X4.5	F37-180-140X4.5TFCF	122.0	15	IN80-140X4.5TFCF	OR129.77X3.53X	4.14
6	165X5.0	F37-196-165X5.0TFCF	150.8	17	IN96-165X5.0TFCF	OR158.42X2.62X	7.03
8	220X6.0	F37-1128-220X6.0TFCF	203.3	16	IN128-220X6.0TFCF	OR209.22X2.62X	12.85
10	273X6.0	F37-1160-273X6.0TFCF	256.2	17	IN160-273X6.0TFCF	OR262.34X3.53X	29.01

Other sizes on request.

Please change suffixes according to material/surface required

Order code suffixes		
Material	Suffix surface and material	Example
Steel, zinc plated, Cr(VI)-free	CF	IN24-50X3.0TFCF
Stainless steel	SS	IN24-50X3.0TFSS



TT – Flare flange connection

Tube to tube connection

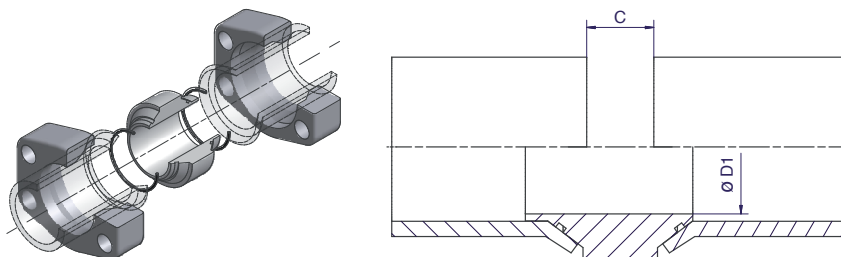

Size Inch	Tube	Flange incl. Insert + 2 x O-Ring Order code	D1	C	Insert incl. 2 x O-Ring Order code	O-Ring Tube Side Order code	Weight (Steel) kg/1 kit
1 1/2	50X3.0	F37-124-50X3.0TTCF	36.0	22	IN24-50X3.0TTCF	OR44.17X1.78X	0.94
2	60X3.0	F37-132-60X3.0TTCF	46.0	24	IN32-60X3.0TTCF	OR53.7X1.78X	1.38
2 1/2	75X3.0	F37-140-75X3.0TTCF	60.0	20	IN40-75X3.0TTCF	OR69.57X1.78X	1.79
3	90X3.5	F37-148-90X3.5TTCF	72.0	30	IN48-90X3.5TTCF	OR82.27X1.78X	2.79
3 1/2	100X4.0	F37-156-100X4.0TTCF	88.6	30	IN56-100X4.0TTCF	OR94.97X1.78X	2.60
4	115X4.0	F37-164-115X4.0TTCF	90.0	28	IN64-115X4.0TTCF	OR110X2X	4.45
5	140X4.5	F37-180-140X4.5TTCF	122.0	30	IN80-140X4.5TTCF	OR129.77X3.53X	4.75
6	165X5.0	F37-196-165X5.0TTCF	150.8	34	IN96-165X5.0TTCF	OR158.42X2.62X	8.36
8	220X6.0	F37-1128-220X6.0TTCF			on request		
10	273X6.0	F37-1160-273X6.0TTCF			on request		

Other sizes on request.

Please change suffixes according to material/surface required

Order code suffixes		
Material	Suffix surface and material	Example
Steel, zinc plated, Cr(VI)-free	CF	F37-124-50X3.0TTCF
Stainless Steel	SS	F37-124-50X3.0TTSS

R – Retaining ring

SAE 1000/ISO 6162-1 footprint

Size Inch	Order code	S	D
1 1/2	R124X	4.0	56.0
2	R132X	4.0	66.0
2 1/2	R140X	4.0	77.0
3	R148X	5.0	93.0
3 1/2	R156X	5.0	110.0
4	R164X	5.0	120.0
5	R180X	6.0	144.0
6	R196X	6.0	174.0
8	R1128X	8.0	232.0
10	R1160X	8.0	286.0

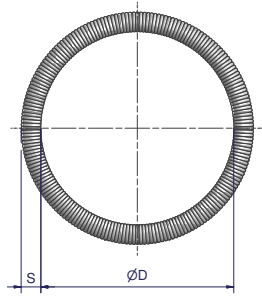

MTF-R – Male thread adapter, BSPP

SAE 1000/ISO 6162-1 footprint

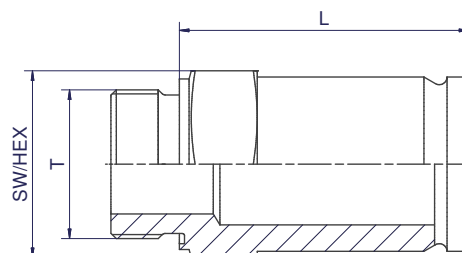
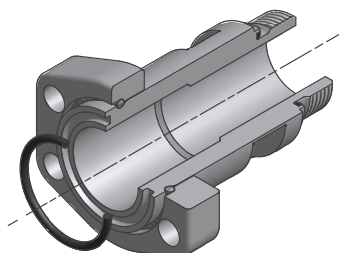

Size Inch	Complete part Order code	Body incl. ED-Seal Order code	L	T	SW/ HEX	Weight body (Steel) kg/1 piece
1 1/2	R-124MTFRCF	MTF124ROMDCF	93	G 1 1/2 A	60	1.29
1 1/2	R-124MTFR11/4CF	MTF124R11/4OMDCF	95	G 1 1/4 A	60	1.32
2	R-132MTFR2CF	MTF132R2OMDCF	97	G 2 A	60	1.83
2	R-132MTFR11/2CF	MTF132R11/2OMDCF	99	G 1 1/2 A	60	1.72
2 1/2	R-140MTFR2CF	MTF140R2OMDCF	136	G 2 A	85	3.32
2 1/2	R-140MTFRCF	MTF140ROMDCF	134	G 2 1/2 A	85	3.34
3	R-148MTFR21/2CF	MTF148R21/2OMDCF	147	G 2 1/2 A	100	4.63
3	R-148MTFRCF	MTF148ROMDCF	145	G 3 A	100	4.97

Other sizes on request.

Please change suffixes according to material/surface required

Order code suffixes		
Material	Suffix surface and material	Example
Steel, zinc plated, Cr(VI)-free	CF	R-120MTFR1CF
Stainless steel	SS	R-120MTFR1SS

FTF-R – Female thread adapter, BSPP

SAE 1000/ISO 6162-1 footprint

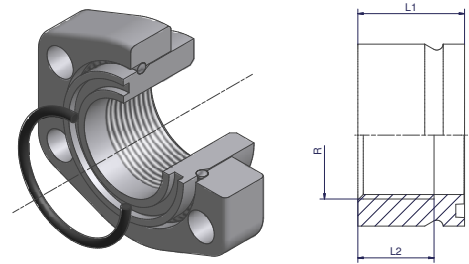

Size Inch	Complete part Order code	Adapter Order code	L1	L2	R	Weight (Steel) kg/1 kit
1 1/2	R-124FTFR11/4CF	FTF124R11/4CFX	45	30	G 1 1/4	0.54
2	R-132FTFR11/2CF	FTF132R11/2CFX	55	40	G 1 1/2	0.92
2 1/2	R-140FTFR2CF	FTF140R2CFX	80	40	G 2	1.58
3	R-148FTFR21/2CF	FTF148R21/2CFX	85	50	G 2 1/2	2.18

Other sizes on request.

Please change suffixes according to material/surface required

Order code suffixes		
Material	Suffix surface and material	Example
Steel, zinc plated, Cr(VI)-free	CF	R-120FTFR1CF
Stainless steel	SS	R-120FTFR1SS



WA – Weld adapter connection

SAE 1000/ISO 6162-1 footprint

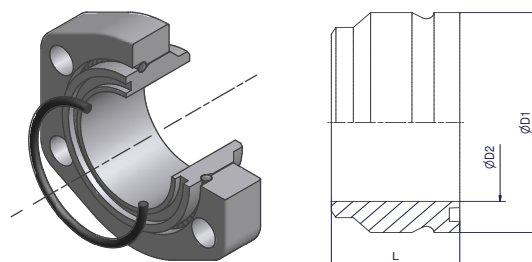

Size Inch	Tube	Complete Part Order code	Weld Adapter Body Order code	Flange Order code	Retaining Ring	O-Ring	D1	D2	L	Weight (Steel) kg/1 kit
1 1/2	50.0X3.0	R-124WA-50X3.0S	WA124-50X3.0SX	R-124-CFX	R124X	OR47.22X3.53X	59.7	39.8	35.0	0.80
1 1/2	48.3X2.6	R-124WA-48.3X2.6S	WA124-48.3X2.6SX	R-124-CFX	R124X	OR47.22X3.53X	59.7	39.8	35.0	0.80
2	60.0X3.0	R-132WA-60X3.0S	WA132-60X3.0SX	R-132-CFX	R132X	OR56.75X3.53X	69.7	50.0	35.0	0.99
2	60.3X2.9	R-132WA-60.3X2.9S	WA132-60.3X2.9SX	R-132-CFX	R132X	OR56.75X3.53X	69.7	50.0	35.0	0.99
2 1/2	75.0X3.0	R-140WA-75X3.0S	WA140-75X3.0SX	R-140-CFX	R140X	OR69.44X3.53X	80.7	62.0	35.0	1.21
2 1/2	76.1X3.2	R-140WA-76.1X3.2S	WA140-76.1X3.2SX	R-140-CFX	R140X	OR69.44X3.53X	80.7	62.0	35.0	1.21
3	88.9X3.05	R-148WA-88.9X3.05S	WA148-88.9X3.05SX	R-148-CFX	R148X	OR85.32X3.53X	97.7	77.8	40.0	1.92
3	88.9X3.6	R-148WA-88.9X3.6S	WA148-88.9X3.6SX	R-148-CFX	R148X	OR85.32X3.53X	97.7	77.8	40.0	1.92
3 1/2	100X4.0	R-156WA-100X4.0S	WA156-100X4.0SX	R-156-CFX	R156X	OR98.02X3.53X	114.7	89.8	40.0	2.70
4	114.3X4.5	R-164WA-114.3X4.5S	WA164-114.3X4.5SX	R-164-CFX	R164X	OR110.72X3.53X	124.7	99.8	40.0	3.11
4	115X4.0	R-164WA-115X4.0S	WA164-115X4.0SX	R-164-CFX	R164X	OR110.72X3.53X	124.7	99.8	40.0	3.09
5	139.7X5.6	R-180WA-139.7X5.6S	WA180-139.7X5.6SX	R-180-CFX	R180X	OR136.12X3.53X	149.7	124.8	45.0	4.92
5	140X4.5	R-180WA-140X4.5S	WA180-140X4.5SX	R-180-CFX	R180X	OR136.12X3.53X	149.7	124.8	45.0	4.87
5	141.3X3.4	R-180WA-141.3X3.4S	WA180-141.3X3.4SX	R-180-CFX	R180X	OR136.12X3.53X	149.7	124.8	45.0	4.91
6	165X5.0	R-196WA-165X5.0S	WA196-165X5.0SX	R-196-CFX	R196X	OR158.34X3.53X	179.7	149.8	50.0	8.02
6	168.3X2.77	R-196WA-168.3X2.77S	WA196-168.3X2.77SX	R-196-CFX	R196X	OR158.34X3.53X	179.7	149.8	50.0	8.06
6	168.3X3.4	R-196WA-168.3X3.4S	WA196-168.3X3.4SX	R-196-CFX	R196X	OR158.34X3.53X	179.7	149.8	50.0	8.06
8	219.1X3.76	R-1128WA-219.1X3.76S	WA1128-219.1X3.76SX	R-1128-CFX	R1128X	OR219.3X5.7X	239.7	206.5	60.0	13.55
8	219.1X8.18	R-1128WA-219.1X8.18S	WA1128-219.1X8.18SX	R-1128-CFX	R1128X	OR219.3X5.7X	239.7	206.5	60.0	13.55
8	220X6.0	R-1128WA-220X6.0S	WA1128-220X6.0SX	R-1128-CFX	R1128X	OR219.3X5.7X	239.7	208.0	60.0	13.62
10	273X6.0	R-1160WA-273X6.0S	WA1160-273X6.0SX	R-1160-CFX	R1160X	OR269.3X5.7X	295.0	255.0	70.0	32.23
10	274.1X9.27	R-1160WA-274.1X9.27S	WA1160-274.1X9.27SX	R-1160-CFX	R1160X	OR269.3X5.7X	295.0	255.0	70.0	32.39

Other sizes on request.

Please change suffixes according to material/surface required

Order code suffixes		
Material	Suffix surface and material	Example
Steel	S	R-124WA-50x3.0S
Stainless steel	SS	R-124WA-50x3.0SS

WAF – Weld adapter flat connection

SAE 1000/ISO 6162-1 footprint

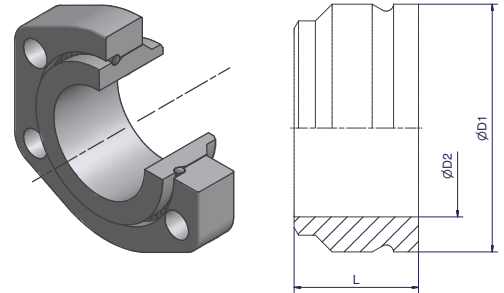

Size Inch	Tube	Complete Part Order code	Weld Adapter Body Order code	Flange Order code	Retaining Ring	D1	D2	L	Weight (Steel) kg/1 kit
1 1/2	50.0X3.0	R-124WA-50X3.0FS	WA124-50X3.0FSX	R-124-CFX	R124X	59.7	39.8	35.0	0.80
1 1/2	48.3X2.6	R-124WA-48.3X2.6FS	WA124-48.3X2.6FSX	R-124-CFX	R124X	59.7	39.8	35.0	0.80
2	60.0X3.0	R-132WA-60X3.0FS	WA132-60X3.0FSX	R-132-CFX	R132X	69.7	50.0	35.0	0.99
2	60.3X2.9	R-132WA-60.3X2.9FS	WA132-60.3X2.9FSX	R-132-CFX	R132X	69.7	50.0	35.0	1.01
2 1/2	75.0X3.0	R-140WA-75X3.0FS	WA140-75.0X3.0FSX	R-140-CFX	R140X	80.7	62.0	35.0	1.21
2 1/2	76.1X3.2	R-140WA-76.1X3.2FS	WA140-76.1X3.2FSX	R-140-CFX	R140X	80.7	62.0	35.0	1.21
3	88.9X3.05	R-148WA-88.9X3.05FS	WA148-88.9X3.05FSX	R-148-CFX	R148X	97.7	77.8	40.0	1.94
3	88.9X3.6	R-148WA-88.9X3.6FS	WA148-88.9X3.6FSX	R-148-CFX	R148X	97.7	77.8	40.0	1.94
3 1/2	100X4.0	R-156WA-100X4.0FS	WA156-100X4.0FSX	R-156-CFX	R156X	114.7	89.8	40.0	2.73
4	114.3X4.5	R-164WA-114.3X4.5FS	WA164-114.3X4.5FSX	R-164-CFX	R164X	124.7	99.8	40.0	3.15
4	115X4.0	R-164WA-115X4.0FS	WA164-115X4.0FSX	R-164-CFX	R164X	124.7	99.8	40.0	3.13
5	139.7X5.6	R-180WA-139.7X5.6FS	WA180-139.7X5.6FSX	R-180-CFX	R180X	149.7	124.8	45.0	4.96
5	140X4.5	R-180WA-140X4.5FS	WA180-140x4.5FSX	R-180-CFX	R180X	149.7	124.8	45.0	4.92
5	141.3X3.4	R-180WA-141.3X3.4FS	WA180-141.3X3.4FSX	R-180-CFX	R180X	149.7	124.8	45.0	4.93
6	165X5.0	R-196WA-165X5.0FS	WA196-165X5.0FSX	R-196-CFX	R196X	179.7	149.8	50.0	8.08
6	168.3X2.77	R-196WA-168.3X2.77FS	WA196-168.3X2.77FSX	R-196-CFX	R196X	179.7	149.8	50.0	8.16
6	168.3X3.4	R-196WA-168.3X3.4FS	WA196-168.3X3.4FSX	R-196-CFX	R196X	179.7	149.8	50.0	8.16
8	219.1X3.76	R-1128WA-219.1X3.76FS	WA1128-219.1X3.76FSX	R-1128-CFX	R1128X	239.7	206.5	60.0	13.75
8	219.1X8.18	R-1128WA-219.1X8.18FS	WA1128-219.1X8.18FSX	R-1128-CFX	R1128X	239.7	206.5	60.0	13.75
8	220X6.0	R-1128WA-220X6.0FS	WA1128-220X6.0FSX	R-1128-CFX	R1128X	239.7	208.0	60.0	13.81
10	273X6.0	R-1160WA-273X6FS	WA1160-273X6FSX	R-1160-CFX	R1160X	295.0	255.0	70.0	32.47
10	274.1X9.27	R-1160WA-274.1X9.27FS	WA1160-274.1X9.27FSX	R-1160-CFX	R1160X	295.0	255.0	70.0	32.49

Other sizes on request.

Please change suffixes according to material/surface required

Order code suffixes		
Material	Suffix surface and material	Example
Steel	S	R-124WA-50X3.0FS
Stainless steel	SS	R-124WA-50X3.0FSS



BF – Bulkhead flange flat face

SAE 1000/ISO 6162-1 footprint

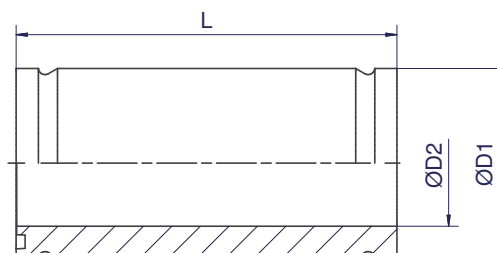
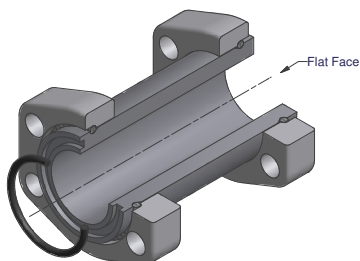

Size Inch	Complete Part Order code	Bulkhead Body Order code	O-Ring	D1	D2	L	Weight body (Steel) kg/1 piece
1 1/2	R-124FBFS	BF124FSX	OR47.22X3.53X	59.7	39.8	165	1.98
2	R-132FBFS	BF132FSX	OR56.75X3.53X	69.7	50.0	165	2.34
2 1/2	R-140FBFS	BF140FSX	OR69.44X3.53X	80.7	62.0	175	2.81
3	R-148FBFS	BF148FSX	OR85.32X3.53X	97.7	77.8	200	4.20
3 1/2	R-156FBFS	BF156FSX	OR98.02X3.53X	114.7	89.8	200	6.15
4	R-164FBFS	BF164FSX	OR110.72X3.53X	124.7	99.8	200	6.75
5	R-180FBFS	BF180FSX	OR136.12X3.53X	149.7	124.8	200	8.22
6	R-196FBFS	BF196FSX	OR158.34X3.53X	179.7	149.8	215	12.81
8	R-1128FBFS	BF1128FSX	OR219.3X5.7X	239.7	206.5	240	21.18
10	R-1160FBFS	BF1160FSX	OR269.3X5.7X	295.0	255.0	270	35.59

Other sizes on request.

Please change suffixes according to material/surface required

Order code suffixes		
Material	Suffix surface and material	Example
Steel	S	R-132FBFS
Stainless steel	SS	R-132FBFSS

Parflange® F37 – SAE 1000/ISO 6162-1 footprint

RF – Reducer flange flat face

SAE 1000/ISO 6162-1 footprint

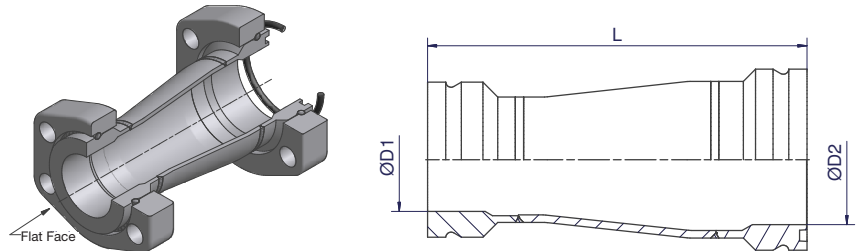

Size Inch	Complete Part Order code	Reducer Body Order code	O-Ring	D1	D2	L	Weight body (Steel) kg/1 piece	W.P. bar
2 - 1 1/2	R-132-124FRFCF	RF132-124FOMDCF	OR56.75X3.53X	39.8	50.0	146	0.91	70
2 1/2 - 1 1/2	R-140-124FRFCF	RF140-124FOMDCF	OR69.44X3.53X	39.8	62.0	160	1.04	70
2 1/2 - 2	R-140-132FRFCF	RF140-132FOMDCF	OR69.44X3.53X	50.0	62.0	160	1.25	70
3 - 1 1/2	R-148-124FRFCF	RF148-124FOMDCF	OR85.32X3.53X	39.8	77.8	165	1.34	70
3 - 2	R-148-132FRFCF	RF148-132FOMDCF	OR85.32X3.53X	50.0	77.8	165	1.45	70
3 - 2 1/2	R-148-140FRFCF	RF148-140FOMDCF	OR85.32X3.53X	62.0	77.8	168	1.53	70
3 1/2 - 2 1/2	R-156-140FRFCF	RF156-140FOMDCF	OR98.02X3.53X	62.0	89.8	177	2.00	50
3 1/2 - 3	R-156-148FRFCF	RF156-148FOMDCF	OR98.02X3.53X	77.8	89.8	182	2.32	50
4 - 3	R-164-148FRFCF	RF164-148FOMDCF	OR110.72X3.53X	77.8	99.8	182	2.43	50
5 - 4	R-180-164FRFCF	RF180-164FOMDCF	OR136.12X3.53X	99.8	124.8	214	3.86	50

Other sizes on request.

Please change suffixes according to material/surface required

Order code suffixes		
Material	Suffix surface and material	Example
Steel, zinc plated, Cr(VI)-free	CF	RF132-124-FRFCF
Stainless steel	SS	RF132-124-FRFSS



LF – Elbow flange flat face

SAE 1000/ISO 6162-1 footprint

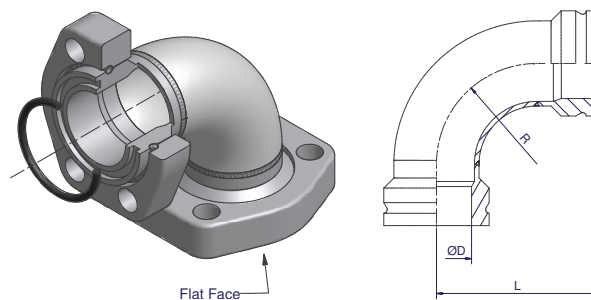

Size Inch	Elbow Flange Complete Part Order code	Elbow Flange body Order code	O-Ring	D	L	R	Weight body (Steel) kg/1 piece	W.P. bar
1 1/2	R-124FLFCF	LF124FOMDCF	OR47.22X3.53X	39.8	94	57.0	0.85	70
2	R-132FLFCF	LF132FOMDCF	OR56.75X3.53X	50.0	112	76.0	1.18	70
2 1/2	R-140FLFCF	LF140FOMDCF	OR69.44X3.53X	62.0	132	95.0	1.54	70
3	R-148FLFCF	LF148FOMDCF	OR85.32X3.53X	77.8	155	114.0	2.44	70
3 1/2	R-156FLFCF	LF156FOMDCF	OR98.02X3.53X	88.9	184	142.5	3.88	50
4	R-164FLFCF	LF164FOMDCF	OR110.72X3.53X	99.8	195	152.0	4.33	50
5	R-180FLFCF	LF180FOMDCF	OR136.12X3.53X	124.8	235	190.0	6.81	50
6	R-196FLFCF	LF196FOMDCF	OR158.34X3.53X	149.8	304	229.0	11.19	50
8	R-1128FLFCF	LF1128FOMDCF	OR219.3X5.7X	206.5	390	305.0	24.13	50
10	R-1160FLFCF	LF1160FOMDCF	OR269.3X5.7X	255.0	471	381.0	38.39	50

Other sizes on request.

Please change suffixes according to material/surface required

Order code suffixes		
Material	Suffix surface and material	Example
Steel, zinc plated, Cr(VI)-free	CF	R-124FLFCF
Stainless steel	SS	R-124FLFSS

TF/TF-R – TEE flange flat

SAE 1000/ISO 6162-1 footprint

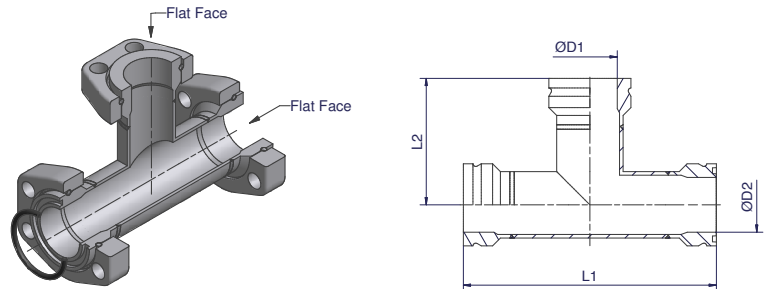

Size Inch	Tee Flange Complete Part Order code	Tee Flange Body Order code	O-Ring	D1	D2	L1	L2	Weight body (Steel) kg/1 piece	W.P. bar
1 1/2	R-124FTFCF	TF124FOMDCF	OR47.22X3.53X	39.8	39.8	184	92	1.30	70
2-1 1/2-2	R-132-124-132FTFCF	TF132-124-132FOMDCF	OR56.75X3.53X	39.8	50.0	200	97	1.58	70
2	R-132FTFCF	TF132FOMDCF	OR56.75X3.53X	50.0	50.0	198	99	1.67	70
2 1/2-2-21/2	R-140-132-140FTFCF	TF140-132-140FOMDCF	OR69.44X3.53X	50.0	62.0	222	105	2.02	70
2 1/2	R-140FTFCF	TF140FOMDCF	OR69.44X3.53X	62.0	62.0	222	111	2.09	70
3-2 1/2-3	R-148-140-148FTFCF	TF148-140-148FOMDCF	OR85.32X3.53X	62.0	77.8	252	118	2.91	70
3	R-148FTFCF	TF148FOMDCF	OR85.32X3.53X	77.8	77.8	252	126	3.22	70
3 1/2-3-3 1/2	R-156-148-156FTFCF	TF156-148-156FOMDCF	OR98.02X3.53X	77.8	89.8	283	137	4.47	50
3 1/2	R-156FTFCF	TF156FOMDCF	OR98.02X3.53X	89.8	89.8	283	140	4.86	50
4-3-4	R-164-148-164FTFCF	TF164-148-164FOMDCF	OR110.72X3.53X	77.8	99.8	293	138	4.84	50
4	R-164FTFCF	TF164FOMDCF	OR110.72X3.53X	99.8	99.8	293	145	5.37	50
5-4-5	R-180-164-180FTFCF	TF180-164-180FOMDCF	OR136.12X3.53X	99.8	124.8	340	157	7.39	50
5	R-180FTFCF	TF180FOMDCF	OR136.12X3.53X	124.8	124.8	341	169	8.04	50
6-5-6	R-196-180-196FTFCF	TF196-180-196FOMDCF	OR158.34X3.53X	124.8	149.8	426	188	11.49	50
6	R-196FTFCF	TF196FOMDCF	OR158.34X3.53X	149.8	149.8	439	218	12.87	50
8-6-8	R-1128-196-1128FTFCF	TF1128-196-1128FOMDCF	OR219.3X5.7X	149.8	206.5	528	243	22.66	50
8	R-1128FTFCF	TF1128FOMDCF	OR219.3X5.7X	206.5	206.5	529	263	25.58	50
10	R-1160FTFCF	TF1160FOMDCF	OR269.3X5.7X	255.0	255.0	612	306	40.16	50

Other sizes on request.

Please change suffixes according to material/surface required

Order code suffixes		
Material	Suffix surface and material	Example
Steel, zinc plated, Cr(VI)-free	CF	R-124FTFCF
Stainless steel	SS	R-124FTFSS



BFV – Blind flange

SAE 1000/ISO 6162-1

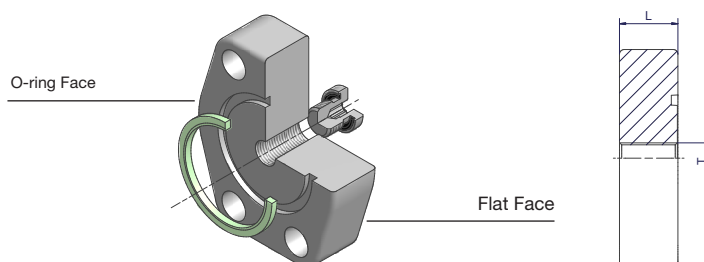

Size Inch	Flange incl. VSTI-ED and Seal Order code	L	T	Weight body (Steel) kg/1 piece
1 1/2	F37-124BFVCF	20	G 1/4	0.9
2	F37-132BFVCF	25	G 1/4	1.5
2 1/2	F37-140BFVCF	30	G 1/4	2.3
3	F37-148BFVCF	30	G 1/4	3.2
3 1/2	F37-156BFVCF	30	G 1/4	4.0
4	F37-164BFVCF	39	G 1/4	6.1
5	F37-180BFVCF	39	G 1/4	8.3
6	F37-196BFVCF	39	G 1/4	12.9
8	F37-1128BFVCF	39	G 1/4	23.1
10	F37-1160BFVCF	50	G 1/4	50.2

Other sizes on request.

Please change suffixes according to material/surface required

Order code suffixes		
Material	Suffix surface and material	Example
Steel, zinc plated, Cr(VI)-free	CF	F37-124BFVCF
Stainless steel	SS	F37-124BFVSS

Parflange® F37 – SAE 1000/ISO 6162-1 footprint

CPML – F37 inner plate

SAE 1000/ISO 6162-1 footprint

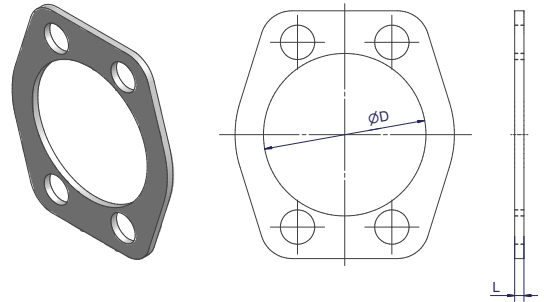

Size Inch	F37 Inner Plate Order code	L	D	Weight (Steel) kg/1 piece
1 1/2	24CPMLCFX	3.5	39.8	0.13
2	32CPMLCFX	3.5	50.0	0.15
2 1/2	40CPMLCFX	3.5	62.0	0.19
3	48CPMLCFX	3.5	77.8	0.25
3 1/2	56CPMLCFX	3.5	89.8	0.30
4	64CPMLCFX	3.5	99.8	0.34
5	80CPMLCFX	3.5	124.8	0.41
6	96CPMLCFX	3.5	149.8	0.68
8	128CPMLCFX	4.5	206.5	1.52
10	160CPMLCFX	4.5	255.0	2.75

Other sizes on request.
Please change suffixes according to material/surface required.

Order code suffixes		
Material	Suffix surface and material	Example
Steel	CF	24CPMLCFX
Stainless steel	SS	24CPMLSSX

F37S/F37RS – F37 seal

SAE 1000/ISO 6162-1

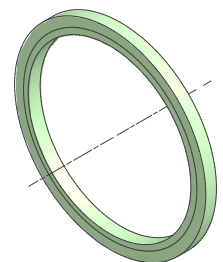

Size Inch	F37 Seal (F37 seal for flaring system)
1 1/2	F37S24X
2	F37S32X
2 1/2	F37S40X
3	F37S48X
3 1/4	F37S56X
4	F37S64X
5	F37S80X
6	F37S196X
8	F37S1128X
10	F37S1160X

Sealing: Polyurethane
Material properties and applications see page 22.
Other sizes on request.



Bolts and nuts for flange

SAE 1000/ISO 6162-1 footprint



F37 Flare Flange

Size Inch	Flange	Soft Seal / Flat Face		Nut
		Recommended bolts Tube to Port	Recommended bolts Tube to Tube	
1 1/2	F37-124-CFX	4 x ZYLS12X40	4 x ZYLS12X70	4 x ISO4032-M12
2	F37-132-CFX	4 x ZYLS12X45	4 x ZYLS12X80	4 x ISO4032-M12
2 1/2	F37-140-CFX	4 x ZYLS12X50	4 x ZYLS12X90	4 x ISO4032-M12
3	F37-148-CFX	4 x ZYLS16X60	4 x ZYLS16X100	4 x ISO4032-M16
3 1/2	F37-156-CFX	4 x ZYLS16X60	4 x ZYLS16X100	4 x ISO4032-M16
4	F37-164-CFX	4 x ZYLS16X65	4 x ZYLS16X120	4 x ISO4032-M16
5	F37-180-CFX	4 x ZYLS16X65	4 x ZYLS16X120	4 x ISO4032-M16
6	F37-196-CFX	6 x ZYLS16X65	6 x ZYLS16X110	6 x ISO4032-M16
8	F37-1128-CFX	8 x ZYLS20X80	8 x ZYLS20X145	8 x ISO4032-M20
10	F37-1160-CFX	8 x ZYLS20X80	8 x ZYLS20X150	8 x ISO4032-M20

Retaining Ring Flange

Size Inch	Flange	Soft Seal / Flat Face		Nut
		Recommended bolts Tube to Port	Recommended bolts Tube to Tube	
1 1/2	R-124-CFX	4 x ZYLS12X40	4 x ZYLS12X65	4 x ISO4032-M12
2	R-132-CFX	4 x ZYLS12X40	4 x ZYLS12X65	4 x ISO4032-M12
2 1/2	R-140-CFX	4 x ZYLS12X40	4 x ZYLS12X65	4 x ISO4032-M12
3	R-148-CFX	4 x ZYLS16X50	4 x ZYLS16X80	4 x ISO4032-M16
3 1/2	R-156-CFX	4 x ZYLS16X55	4 x ZYLS16X90	4 x ISO4032-M16
4	R-164-CFX	4 x ZYLS16X55	4 x ZYLS16X90	4 x ISO4032-M16
5	R-180-CFX	4 x ZYLS16X70	4 x ZYLS16X110	4 x ISO4032-M16
6	R-196-CFX	6 x ZYLS16X70	6 x ZYLS16X110	6 x ISO4032-M16
8	R-1128-CFX	8 x ZYLS20X70	8 x ZYLS20X120	8 x ISO4032-M20
10	R-1160-CFX	8 x ZYLS20X80	8 x ZYLS20X150	8 x ISO4032-M20

Bolts and nuts are not included in complete part numbers.

Latest information about nuts and bolts see www.parker.com/hpce -> Resources -> Installation Guides & Manuals

Please add the suffixes according to the bolt quality

	Steel	Stainless Steel
Grade	8.8 zinc plated (VZX)	A4-80X
Bolt	ZYLS16X60VZX	ZYLS16X60A4-80X
Nut	ISO4032-M12-8VZX	ISO4032-M12-80X

AP – SAE flange locking plate

SAE 1000/ISO 6162-1

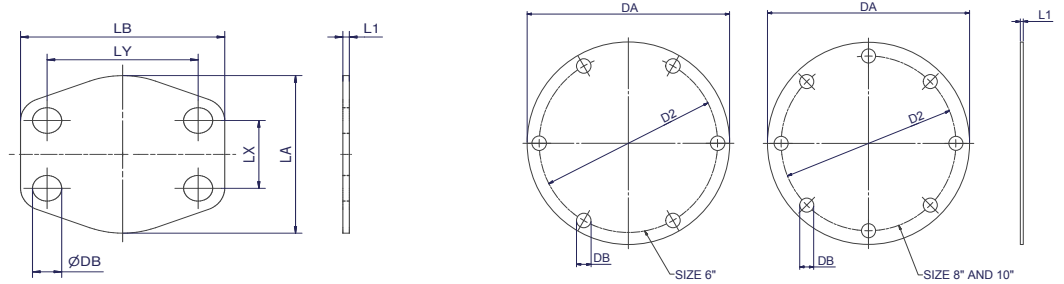

Nom. flange size		Order code	L1	LA	LB	LX	LY	DB	Weight body (Steel) kg/1 piece
SAE (In)	ISO (DN)								
1 1/2	38	24AP1	3	83	94	35.7	69.9	13.5	0.02
2	51	32AP1	3	97	102	42.9	77.8	13.5	0.02
2 1/2	64	40AP1	3	109	114	50.8	88.9	13.5	0.03
3	76	48AP1	4	131	135	61.9	106.4	17.0	0.06
3 1/2	89	56AP1	4	140	152	69.9	120.7	17.0	0.07
4	102	64AP1	4	146	162	77.8	130.2	17.0	0.08
5	127	80AP1	4	181	184	92.1	152.4	17.0	0.11
				DA		D2		DB	
6		96AP1	3.5	236		208		17.0	1.33
8		128AP1	4	318		275		22.0	2.40
10		160AP1	4	409		345		22.0	4.04

This flange locking plate to be not used under pressure!

Please change suffixes according to material/surface required

Order code suffixes			
Material	Suffix surface and material	Example	Description
Steel, zinc plated, Cr(VI)-free	CF	8AP1CF	only locking plate
Stainless steel	SS	8AP1SS	only locking plate
Steel (zinc plated, Cr(VI)-free), SBR 70 Shore A	CFSBR70	8AP1CFSBR70	locking incl. rubber plate L1 increases due to rubber plate



KH - Ball valve drilled and tapped for SAE Flanges

SAE 1000/ISO 6162-1 footprint

Material Steel

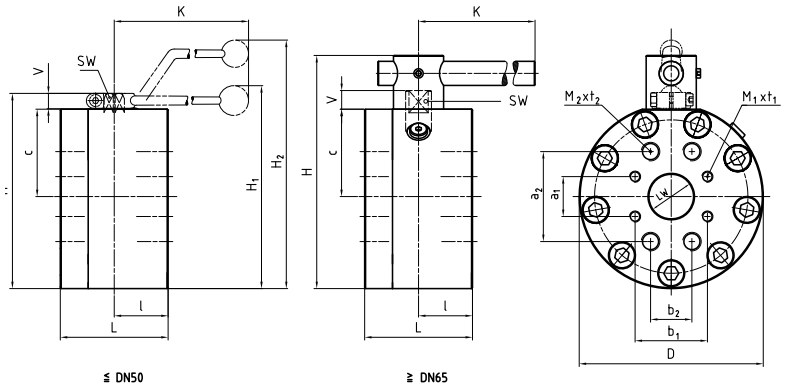

Size Inch	Order code	DN	LW	L	I	D	H	c	V	K	SW	SAE 3000 boring pattern				SAE 6000 boring pattern				H1	H2	Material Code	Lever	Weight-kg	W.P. bar
												a1	b1	M1	t1	a2	b2	M2	t2						
1 1/2	KH24-38CF	40	38	110	55	165	178	78	17	306	17	35.7	69.9	M12	20	79.4	36.5	M16	27	-	252	212A	St	17.10	210/420
2	KH32-48CF	50	48	116	58	198	210	94	17	306	17	42.9	77.8	M12	20	96.8	44.5	M20	28	-	284	212A	St	24.60	210/420
2 1/2	KH40-63CF	65	63	170	75	218	275	100	20	600	16	88.9	50.8	M12	19	123.8	58.7	M24	41	-	-	282A	St	44.40	175/420
3	KH48-76CF	80	76	170	79	258	315	115	26	600	19	106.4	61.9	M16	24	152.4	71.4	M30	47	-	-	282A	St	54.90	160/420

Steel ball valves 1 1/2" up to 3" with SAE 3000 and SAE 6000 boring pattern. The bore pattern for 2 1/2" and 3" is turned to 90°.

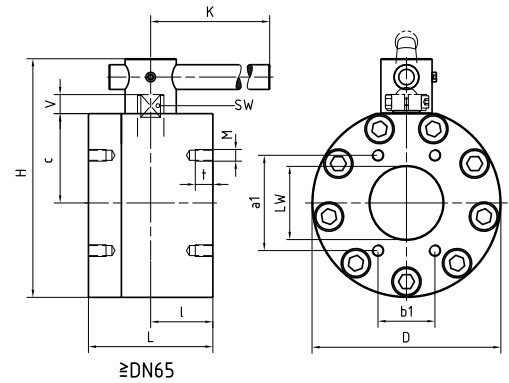
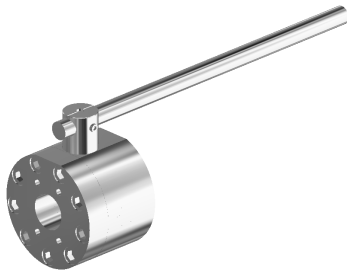

Size Inch	Order code	DN	LW	L	I	D	H	c	V	K	SW	a1	b1	M	t	Material Code	Lever	Weight-kg	W.P. bar
4	KH364-100CF	100	100	170	85	258	326	122	27	900	24	130.2	77.8	M16	24	282A	St	60.5	35
5	KH380-118CF	125	118	210	105	295	377	140	33	900	36	152.4	92.1	M16	30	282A	St	95.5	35

Steel ball valves 4" up to 5" with SAE 3000 only boring pattern. Other sizes on request.

Please change suffixes according to material/surface required

Order code suffixes		
Material	Suffix surface and material	Example
Steel, zinc plated, Cr(VI)-free	CF	KH32-48CF

	Material 212A	Material 282A
Body	Steel	Steel
Ball	Steel	Steel
Stem	Steel	Stainless Steel
Ball seats	POM	POM
O-Ring	NBR	NBR
Tmin / Tmax	-10°C / 100°C	-10°C / 100°C

KH - Ball valve drilled and tapped for SAE Flanges

SAE 1000/ISO 6162-1 footprint
Material Stainless Steel

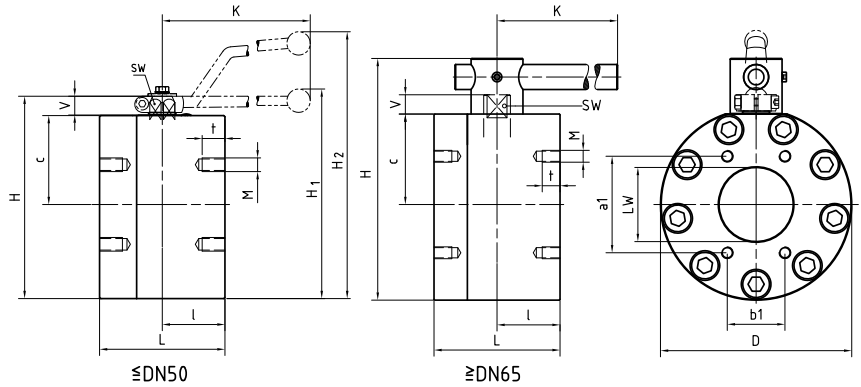
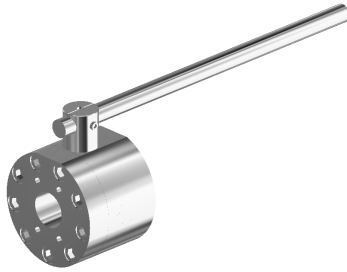

Size Inch	Order code	DN	LW	L	I	D	H	c	V	K	SW	a1	b1	M	t	H1	H2	Material Code	Lever	Weight-kg	W.P. bar
1 1/2	KH324-38SS	40	38	110	55	165	178	78	17	320	17	69.9	35.7	M12	20	187	-	442A	Al	17.1	210
2	KH332-48SS	50	48	116	58	198	210	94	17	320	17	77.8	42.9	M12	20	219	-	442A	Al	24.6	210
2 1/2	KH340-63SS	65	63	150	75	198	259	94	20	600	16	88.9	50.8	M12	19	-	-	442A	St	33.5	175
3	KH348-76SS	80	76	150	79	218	284	104	26	600	19	106.4	61.9	M16	24	-	-	442A	St	40.0	160
4	KH364-100SS	100	100	170	85	258	326	122	27	900	24	130.2	77.8	M16	24	-	-	442A	St	60.5	35
5	KH380-118SS*	125	118	210	105	295	377	140	33	900	36	152.4	92.1	M16	30	-	-	442A	St	95.5	35

Other sizes on request.

Please change suffixes according to material/surface required

Order code suffixes		
Material	Suffix surface and material	Example
Stainless steel	SS	KH32-48SS

	Material 442A
Body	Stainless Steel
Ball	Stainless Steel
Stem	Stainless Steel
Ball seats	POM
O-Ring	NBR
Tmin / Tmax	-30°C / 100°C

*For these ball valves Tmin / Tmax = -10°C / 100°C



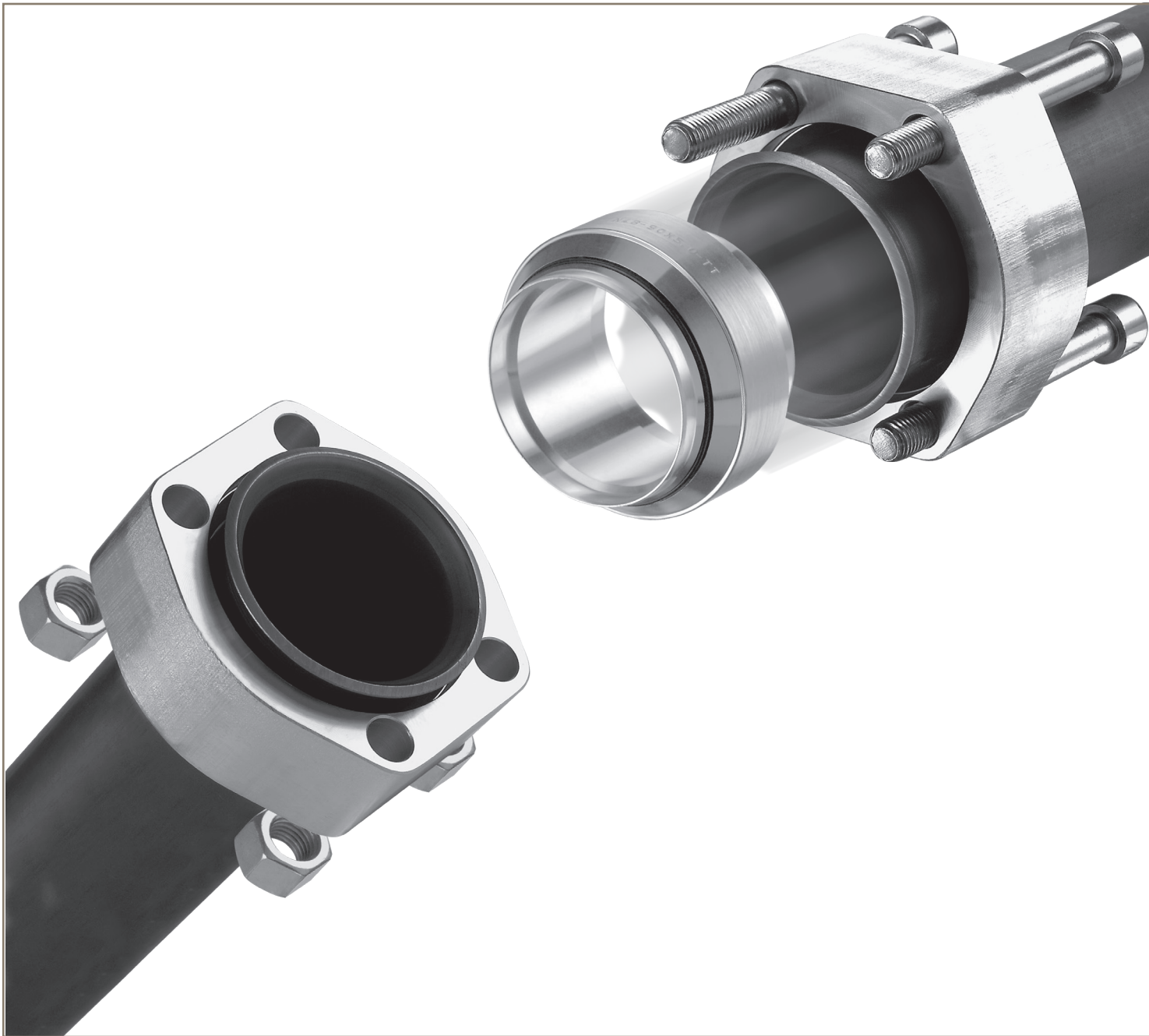









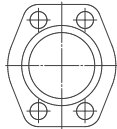
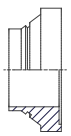
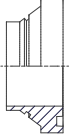
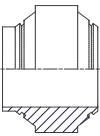

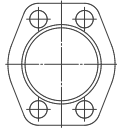

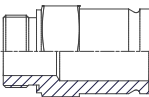
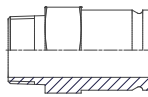
SAE 3000 System

210 – 350 bar

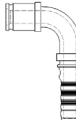
ENGINEERING YOUR SUCCESS.

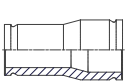
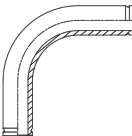
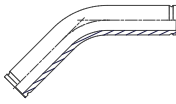
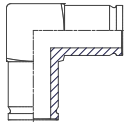
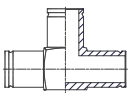
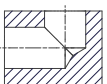
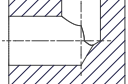
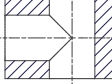
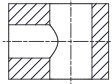
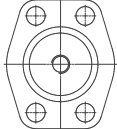
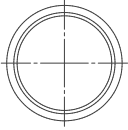
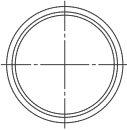
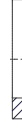
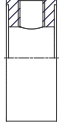
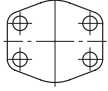
Programme overview SAE 3000/ISO 6162-1 footprint

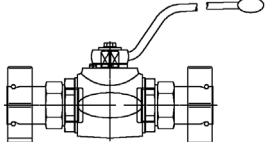
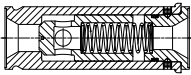
Parflange® F37 connection parts	Flanges  F37 – p.61/62					
	Inserts     TFB – p.65 TFV – p.66 TT – p.67 TF – p.68				Sleeve  SL – p.69	
Retaining ring connection parts	Flanges    R – p.63 R-Ring – p.70 PSC – p.64					
	Male / Female    MTF-R – p.71 MTF-N – p.72 FTF-R – p.73			Hose    Hose – p.74		Weld  WA – p.75/76
	Tube to Tube       BF – p.77 RF – p.78 FB90 – p.79/81 FB45 – p.80/82 LF – p.83 TF – p.84					
SAE connection parts	Blocks      LB – p.85 LBR – p.86 TB – p.87 TBR – p.88 BFV – p.89					
Seals Adapter Bolts	Components      BS – p.90 F37S – p.90 AO – p.91 TBT – p.92 AP – p.93				Bolts and Nuts  p.94	
Ball valves	   KH – p.95/96 KH-R – p.97 RHD-R – p.98					



F37 – Flare flange | SAE 3000/ISO 6162-1 footprint

SAE 3000/ISO 6162-1

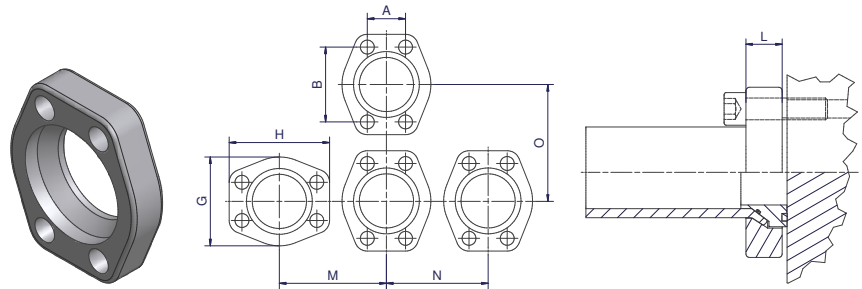

Parflange F37 flange dimensions

*Jump size flanges (no adapter sleeves (SL...) necessary).

Size Inch	Flange Order code	A	B	G	H	M	N	O	L	Weight body (Steel) kg/1 piece	W.P. bar
1/2	F37-308-CFX	17.5	38.1	46	54	55	51	59	19	0.17	350
1/2	F37-308/16-CFX*	17.5	38.1	46	54	55	51	59	19	0.22	350
1/2	F37-308/20-CFX*	17.5	38.1	46	54	55	51	59	19	0.20	350
3/4	F37-312-CFX	22.3	47.6	52	65	63	57	70	20	0.25	350
1	F37-316-CFX	26.2	52.4	60	71	69	64	75	24	0.30	350
1	F37-316/25-CFX*	26.2	52.4	60	71	69	64	75	24	0.45	350
1	F37-316/30-CFX*	26.2	52.4	60	71	69	64	75	24	0.39	350
1 1/4	F37-320-CFX	30.2	58.7	68	79	81	78	84	22	0.46	280
1 1/4	F37-320/38-CFX*	30.2	58.7	68	79	81	78	84	22	0.46	280
1 1/2	F37-324-CFX	35.7	69.9	78	93	93	87	99	25	0.68	280
1 1/2	F37-324/42-CFX*	35.7	69.9	78	93	93	87	99	25	0.75	280
2	F37-332-CFX	42.9	77.8	97	102	104	102	107	33	0.98	280
2 1/2	F37-340-CFX	50.8	88.9	109	116	117	114	120	44	1.63	210
3	F37-348-CFX	61.9	106.4	132	135	138	136	141	50	2.79	210

Parflange F37 threaded flange dimensions

*Jump size flanges (no adapter sleeves (SL...) necessary).

Size Inch	Flange Order code	A	B	G	H	M	N	O	L	Thread	Weight body (Steel) kg/1 piece	W.P. bar
1/2	F37-308T-CFX	17.5	38.1	46	54	55	51	59	19	M08	0.17	350
3/4	F37-312T-CFX	22.3	47.6	52	65	63	57	70	20	M10	0.25	350
1	F37-316T-CFX	26.2	52.4	60	71	69	64	75	24	M10	0.30	350
1	F37-316/30T-CFX*	26.2	52.4	60	71	69	64	75	24	M10	0.39	350
1 1/4	F37-320T-CFX	30.2	58.7	68	79	81	78	84	22	M10	0.46	280
1 1/4	F37-320/38T-CFX*	30.2	58.7	68	79	81	78	84	22	M10	0.46	280
1 1/2	F37-324T-CFX	35.7	69.9	78	93	93	87	99	25	M10	0.68	280
2	F37-332T-CFX	42.9	77.8	97	102	104	102	107	33	M12	0.98	280
2 1/2	F37-340T-CFX	50.8	88.9	109	116	117	114	120	44	M12	1.63	210
3	F37-348T-CFX	61.9	106.4	132	135	138	136	141	50	M16	2.87	210

Pressure rates related to flanges. Other sizes / jump sizes on request.

Please change suffixes according to material/surface required

Order code suffixes			
Material	Suffix surface and material	Example	Comments
Steel, zinc plated, Cr(VI)-free	CF	F37-320-CFX	
Stainless steel	SS	F37-320-SSX	
Galvanized hot dip zinc	TZN	F37-320-TZNX (Not for threaded flanges available)	on request

Parflange® F37 – SAE 3000/ISO 6162-1

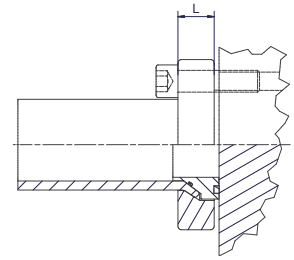
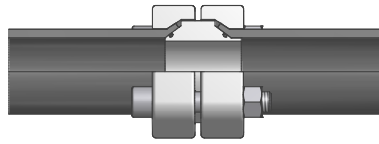

Part combination flaring SAE 3000

Flange Pressure (bar)	Size Inch	Pipe Size	Flange SAE 3000 ISO 6162-1	Insert*	Sleeve
350	1/2	16X2.0	F37-308-CFX	IN08-16X2.0T...	SL08-25-16-CFX**
	1/2	18X2.0	F37-308-CFX	IN08-18X2.0T...	SL08-25-18-CFX
	1/2	20X2.0	F37-308-CFX	IN08-20X2.0T...	SL08-25-20-CFX**
	1/2	20X2.5	F37-308-CFX	IN08-20X2.5T...	SL08-25-20-CFX**
	1/2	25X2.5	F37-308-CFX	IN08-25X2.5T...	
	1/2	25X3.0	F37-308-CFX	IN08-25X3.0T...	
	3/4	20X2.0	F37-312-CFX	IN12-20X2.0T...	SL12-30-20-CFX
	3/4	20X2.5	F37-312-CFX	IN12-20X2.5T...	SL12-30-20-CFX
	3/4	25X2.5	F37-312-CFX	IN12-25X2.5T...	SL12-30-25-CFX
	3/4	25X3.0	F37-312-CFX	IN12-25X3.0T...	SL12-30-25-CFX
	3/4	30X3.0	F37-312-CFX	IN12-30X3.0T...	
	3/4	30X4.0	F37-312-CFX	IN12-30X4.0T...	
	1	25X2.5	F37-316-CFX	IN16-25X2.5T...	SL16-38-25-CFX**
	1	25X3.0	F37-316-CFX	IN16-25X3.0T...	SL16-38-25-CFX**
	1	30X3.0	F37-316-CFX	IN16-30X3.0T...	SL16-38-30-CFX**
	1	30X4.0	F37-316-CFX	IN16-30X4.0T...	SL16-38-30-CFX**
	1	38X2.5	F37-316-CFX	IN16-38X2.5T...	
	1	38X3.0	F37-316-CFX	IN16-38X3.0T...	
1	38X4.0	F37-316-CFX	IN16-38X4.0T...		
1	38X5.0	F37-316-CFX	IN16-38X5.0T...		
280	1 1/4	30X3.0	F37-320-CFX	IN20-30X3.0T...	SL20-42-30-CFX
	1 1/4	30X4.0	F37-320-CFX	IN20-30X4.0T...	SL20-42-30-CFX
	1 1/4	38X3.0	F37-320-CFX	IN20-38X3.0T...	SL20-42-38-CFX**
	1 1/4	38X4.0	F37-320-CFX	IN20-38X4.0T...	SL20-42-38-CFX**
	1 1/4	38X5.0	F37-320-CFX	IN20-38X5.0T...	SL20-42-38-CFX**
	1 1/4	42X3.0	F37-320-CFX	IN20-42X3.0T...	
	1 1/4	42X4.0	F37-320-CFX	IN20-42X4.0T...	
	1 1/2	38X3.0	F37-324-CFX	IN24-38X3.0T...	SL24-50-38-CFX
	1 1/2	38X4.0	F37-324-CFX	IN24-38X4.0T...	SL24-50-38-CFX
	1 1/2	38X5.0	F37-324-CFX	IN24-38X5.0T...	SL24-50-38-CFX
	1 1/2	42X3.0	F37-324-CFX	IN24-42X3.0T...	SL24-50-42-CFX**
	1 1/2	42X4.0	F37-324-CFX	IN24-42X4.0T...	SL24-50-42-CFX**
	1 1/2	50X3.0	F37-324-CFX	IN24-50X3.0T...	
	1 1/2	50X5.0	F37-324-CFX	IN24-50X5.0T...	
	1 1/2	50X6.0	F37-324-CFX	IN24-50X6.0T...	
	2	50X3.0	F37-332-CFX	IN32-50X3.0T...	SL32-60-50-CFX
	2	50X5.0	F37-332-CFX	IN32-50X5.0T...	SL32-60-50-CFX
	2	50X6.0	F37-332-CFX	IN32-50X6.0T...	SL32-60-50-CFX
2	60X3.0	F37-332-CFX	IN32-60X3.0T...		
2	60X5.0	F37-332-CFX	IN32-60X5.0T...		
2	60X6.0	F37-332-CFX	IN32-60X6.0T...		
210	2 1/2	60X3.0	F37-340-CFX	IN40-60X3.0T...	SL40-75-60-CFX
	2 1/2	60X5.0	F37-340-CFX	IN40-60X5.0T...	SL40-75-60-CFX
	2 1/2	60X6.0	F37-340-CFX	IN40-60X6.0T...	SL40-75-60-CFX
	2 1/2	75X3.0	F37-340-CFX	IN40-75X3.0T...	
	2 1/2	75X5.0	F37-340-CFX	IN40-75X5.0T...	
	3	75X3.0	F37-348-CFX	IN48-75X3.0T...	SL48-90-75-CFX
	3	75X5.0	F37-348-CFX	IN48-75X5.0T...	SL48-90-75-CFX
	3	90X3.5	F37-348-CFX	IN48-90X3.5T...	
	3	90X5.0	F37-348-CFX	IN48-90X5.0T...	

Select the complete version: * ...FBCF Bonded Seal version ...FVCF F37 Seal version ...TCF Tube to Tube version ...FCF Flat Face version.

**Jump size flanges available alternatively to adapter sleeve, see page 63.

Other sizes like schedule on request.

Bolts and nuts are not included in complete part numbers. For recommended bolts and nuts see page 94.



R – Retaining ring flange | SAE 3000/ISO 6162-1 footprint

SAE 3000/ISO 6162-1

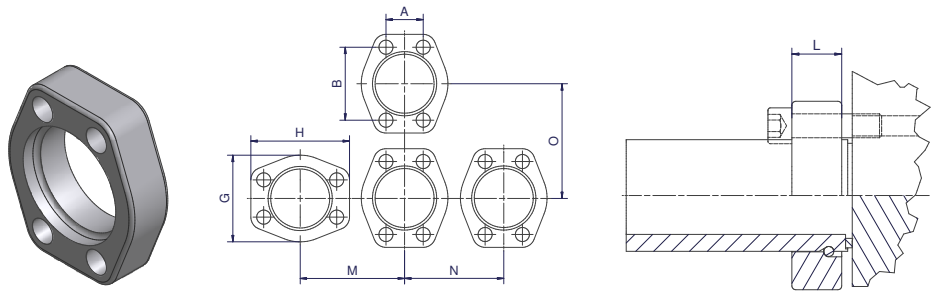

Retaining ring flange dimensions

Size Inch	Order Code	A	B	G	H	M	N	O	L	Weight body (Steel) kg/1 piece	W.P. bar
1/2	R-308-CFX	17.5	38.1	46	54	55	51	59	19	0.2	350
3/4	R-312-CFX	22.3	47.6	52	65	63	57	70	20	0.2	350
1	R-316-CFX	26.2	52.4	59	71	69	64	75	24	0.3	350
1 1/4	R-320-CFX	30.2	58.7	73	79	81	78	84	22	0.5	280
1 1/2	R-324-CFX	35.7	69.9	83	95	93	87	99	25	0.6	280
2	R-332-CFX	42.9	77.8	97	102	104	102	107	33	1.0	280
2 1/2	R-340-CFX	50.8	88.9	109	116	117	114	120	44	1.6	210
3	R-348-CFX	61.9	106.4	132	135	138	136	141	50	2.5	210

Pressure rates related to flanges.
Other sizes like schedule on request.
For all sizes also threaded flanges available (...T-CFX).

Please change suffixes according to material/surface required

Order code suffixes			
Material	Suffix surface and material	Example	Comments
Steel, zinc plated, Cr(VI)-free	CF	R-320-CFX	
Stainless steel	SS	R-320-SSX	
Galvanized hot dip zinc	TZN	R-320-TZNX	on request

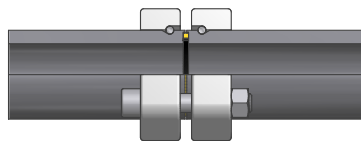

Part combination Bonded seal SAE 3000 connection

Flange pressure (bar)	Size Inch	Pipe Size	Flange	Retaining Ring	Bonded Seal
350	1/2	26X6.0	R-308-CFX	R08X	BS08SNX
	3/4	36X8.0	R-312-CFX	R12X	BS12SNX
	1	39X7.5	R-316-CFX	R16X	BS16SNX
280	1 1/4	46X8.0	R-320-CFX	R20X	BS20SNX
	1 1/2	56X8.5	R-324-CFX	R24X	BS24SNX
	2	66X8.5	R-332-CFX	R32X	BS32SNX
210	2 1/2	80x10.0	R-340-CFX	R40X	BS40SNX
	3	97X12.0	R-348-CFX	R48X	BS48SNX

Bolts and nuts are not included in complete part numbers For recommended bolts and nuts see page 94.

PSC – Pipe seal carrier | SAE 3000/ISO 6162-1 footprint

SAE 3000/ISO 6162-1

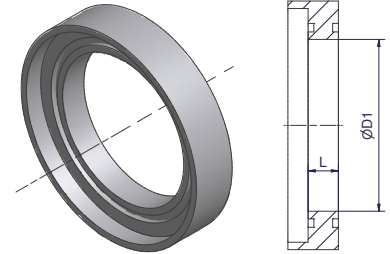

Size Inch	Pipe size	Seal carrier incl. F37 Seal	Seal carrier incl. O-Ring	L	D1	F37 Seal	O-Ring
1 1/4	46X3.0	PSC20-46X8.0VCF	PSC20-46X8.0OCF	8.0	30	F37RS20X	OR34.59X2.62X
1 1/2	56X8.5	PSC24-56X8.5VCF	PSC24-56X8.5OCF	10.0	39	F37RS24X	OR44.12X2.62X
2	66X8.5	PSC32-66X8.5VCF	PSC32-66X8.5OCF	10.0	49	F37RS32X	OR55.25X2.62X
2 1/2	80X10.0	PSC40-80X10VCF	PSC40-80X10OCF	15.0	60	F37RS40X	OR66.27X3.53X
3	97X12.0	PSC48-97X12VCF	PSC48-97X12OCF	15.0	73	F37RS48X	OR78.97X3.53X

Other sizes on request.

Please change suffixes according to material/surface required

Order code suffixes		
Material	Suffix surface and material	Example
Steel, zinc plated, Cr(VI)-free, F37-Seal	VCF	PSC40-80X10VCF
Stainless steel, F37-Seal	VSS	PSC40-80X10VSS
Steel, zinc plated, Cr(VI)-free, O-Ring (NBR)	OCF	PSC40-80X10OCF
Stainless steel, O-Ring (NBR)	OSS	PSC40-80X10OSS

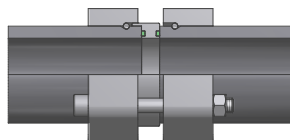

Example of part combinations Pipe seal carrier SAE 3000 connection

Flange pressure (bar)	Size Inch	Pipe Size	Flange	Retaining Ring	Pipe Seal Carrier
280	1 1/4	46X8.0	R-320-CFX	R20X	PSC20-45X8.0VCF
	1 1/2	56X8.5	R-324-CFX	R24X	PSC24-56X8.5VCF
	2	66X8.5	R-332-CFX	R32X	PSC32-66X8.5VCF
210	2 1/2	80X10.0	R-340-CFX	R40X	PSC40-80X10VCF
	3	97X12.0	R-348-CFX	R48X	PSC48-97X12VCF

Other sizes on request

Bolts and nuts are not included in complete part numbers. For recommended bolts and nuts see page 94.



TFB – Flare flange connection

Tube to port connection, bonded seal

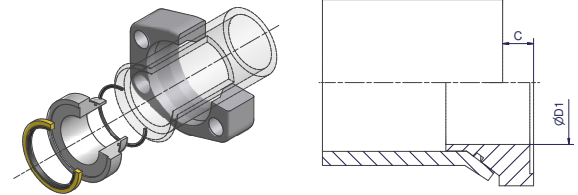

Size		Flange* incl. Insert + Bonded Seal + O-Ring Order code	D1	C	Insert incl.		O-Ring Order code	Weight (Steel) kg/1 kit
Inch	Tube				Bonded Seal + O-Ring Order code	Bonded Seal Order code		
1/2	16X2.0	F37-308-16X2.0TFBCF	9.5	8.0	IN08-16X2.0TFBCF	BS08SNX	OR12X1.0X	0.24
1/2	18X2.0	F37-308-18X2.0TFBCF	11.5	8.0	IN08-18X2.0TFBCF	BS08SNX	OR14X1.0X	0.24
1/2	20X2.0	F37-308-20X2.0TFBCF	13.5	8.0	IN08-20X2.0TFBCF	BS08SNX	OR16X1.0X	0.24
1/2	20X2.5	F37-308-20X2.5TFBCF	13.5	8.0	IN08-20X2.5TFBCF	BS08SNX	OR16X1.0X	0.24
1/2	25X2.5	F37-308-25X2.5TFBCF	13.5	10.0	IN08-25X2.5TFBCF	BS08SNX	OR20X1.0X	0.25
1/2	25X3.0	F37-308-25X3.0TFBCF	13.0	8.0	IN08-25X3.0TFBCF	BS08SNX	OR20X1.0X	0.24
3/4	20X2.0	F37-312-20X2.0TFBCF	13.5	8.0	IN12-20X2.0TFBCF	BS12SNX	OR16X1.0X	0.31
3/4	20X2.5	F37-312-20X2.5TFBCF	12.5	8.0	IN12-20X2.5TFBCF	BS12SNX	OR16X1.0X	0.31
3/4	25X2.5	F37-312-25X2.5TFBCF	17.5	10.0	IN12-25X2.5TFBCF	BS12SNX	OR20X1.0X	0.31
3/4	25X3.0	F37-312-25X3.0TFBCF	16.5	8.0	IN12-25X3.0TFBCF	BS12SNX	OR20X1.0X	0.32
3/4	30X3.0	F37-312-30X3.0TFBCF	19.0	8.5	IN12-30X3.0TFBCF	BS12SNX	OR25X1.0X	0.32
3/4	30X4.0	F37-312-30X4.0TFBCF	19.0	8.5	IN12-30X4.0TFBCF	BS12SNX	OR22X1.0X	1.32
1	25X2.5	F37-316-25X2.5TFBCF	17.5	10.0	IN16-25X2.5TFBCF	BS16SNX	OR20X1.0X	0.39
1	25X3.0	F37-316-25X3.0TFBCF	16.5	8.0	IN16-25X3.0TFBCF	BS16SNX	OR20X1.0X	0.39
1	30X3.0	F37-316-30X3.0TFBCF	21.5	8.5	IN16-30X3.0TFBCF	BS16SNX	OR25X1.0X	0.39
1	30X4.0	F37-316-30X4.0TFBCF	19.5	8.5	IN16-30X4.0TFBCF	BS16SNX	OR22X1.0X	0.39
1	38X2.5	F37-316-38X2.5TFBCF	25.0	9.5	IN16-38X2.5TFBCF	BS16SNX	OR34X1.0X	0.41
1	38X3.0	F37-316-38X3.0TFBCF	25.0	9.0	IN16-38X3.0TFBCF	BS16SNX	OR34X1.0X	0.40
1	38X4.0	F37-316-38X4.0TFBCF	25.0	10.0	IN16-38X4.0TFBCF	BS16SNX	OR30X1.0X	0.40
1	38X5.0	F37-316-38X5.0TFBCF	25.0	8.0	IN16-38X5.0TFBCF	BS16SNX	OR28X1.0X	0.39
1 1/4	30X3.0	F37-320-30X3.0TFBCF	21.5	8.5	IN20-30X3.0TFBCF	BS20SNX	OR25X1.0X	0.57
1 1/4	30X4.0	F37-320-30X4.0TFBCF	19.5	8.5	IN20-30X4.0TFBCF	BS20SNX	OR22X1.0X	0.58
1 1/4	38X3.0	F37-320-38X3.0TFBCF	29.5	9.0	IN20-38X3.0TFBCF	BS20SNX	OR34X1.0X	0.56
1 1/4	38X4.0	F37-320-38X4.0TFBCF	27.0	10.0	IN20-38X4.0TFBCF	BS20SNX	OR30X1.0X	0.57
1 1/4	38X5.0	F37-320-38X5.0TFBCF	25.5	8.0	IN20-38X5.0TFBCF	BS20SNX	OR28X1.0X	0.56
1 1/4	42X3.0	F37-320-42X3.0TFBCF	31.5	10.0	IN20-42X3.0TFBCF	BS20SNX	OR37.82X1.78X	0.57
1 1/4	42X4.0	F37-320-42X4.0TFBCF	31.5	10.0	IN20-42X4.0TFBCF	BS20SNX	OR34X1.0X	0.56
1 1/2	38x3.0	F37-324-38X3.0TFBCF	27.5	9.0	IN24-38X3.0TFBCF	BS20SNX	OR34X1.0X	0.65
1 1/2	38X4.0	F37-324-38X4.0TFBCF	27.5	10.0	IN24-38X4.0TFBCF	BS24SNX	OR30.X1.0X	0.87
1 1/2	38X5.0	F37-324-38X5.0TFBCF	25.0	11.0	IN24-38X5.0TFBCF	BS24SNX	OR28X1.0X	0.87
1 1/2	42X3.0	F37-324-42X3.0TFBCF	35.0	10.0	IN24-42X3.0TFBCF	BS24SNX	OR37.82X1.78X	0.88
1 1/2	42X4.0	F37-324-42X4.0TFBCF	31.5	10.0	IN24-42X4.0TFBCF	BS24SNX	OR34X1.0X	0.87
1 1/2	50X3.0	F37-324-50X3.0TFBCF	36.0	11.0	IN24-50X3.0TFBCF	BS24SNX	OR44.17X1.78X	0.87
1 1/2	50X5.0	F37-324-50X5.0TFBCF	36.0	10.0	IN24-50X5.0TFBCF	BS24SNX	OR41X1.78X	0.87
1 1/2	50X6.0	F37-324-50X6.0TFBCF	35.0	10.0	IN24-50X6.0TFBCF	BS24SNX	OR41X1.78X	0.87
2	50X3.0	F37-332-50X3.0TFBCF	41.5	11.0	IN32-50X3.0TFBCF	BS32SNX	OR44.17X1.78X	1.20
2	50X5.0	F37-332-50X5.0TFBCF	37.5	10.0	IN32-50X5.0TFBCF	BS32SNX	OR41X1.78X	1.22
2	50X6.0	F37-332-50X6.0TFBCF	35.0	10.0	IN32-50X6.0TFBCF	BS32SNX	OR41X1.78X	1.25
2	60X3.0	F37-332-60X3.0TFBCF	46.0	12.0	IN32-60X3.0TFBCF	BS32SNX	OR53.7X1.78X	1.25
2	60X5.0	F37-332-60X5.0TFBCF	46.0	11.0	IN32-60X5.0TFBCF	BS32SNX	OR50.52X1.78X	1.22
2	60X6.0	F37-332-60X6.0TFBCF	45.5	11.0	IN32-60X6.0TFBCF	BS32SNX	OR47.37X1.78X	1.21
2 1/2	60X3.0	F37-340-60X3.0TFBCF	50.0	12.0	IN40-60X3.0TFBCF	BS40SNX	OR53.7X1.78X	1.98
2 1/2	60X5.0	F37-340-60X5.0TFBCF	46.0	11.0	IN40-60X5.0TFBCF	BS40SNX	OR50.52X1.78X	1.99
2 1/2	60X6.0	F37-340-60X6.0TFBCF	45.5	11.0	IN40-60X6.0TFBCF	BS40SNX	OR47.37X1.78X	1.97
2 1/2	75X3.0	F37-340-75X3.0TFBCF	60.0	10.0	IN40-75X3.0TFBCF	BS40SNX	OR69.57X1.78X	1.93
2 1/2	75X5.0	F37-340-75X5.0TFBCF	60.0	10.0	IN40-75X5.0TFBCF	BS40SNX	OR63.22X1.78X	1.95
3	75X3.0	F37-348-75X3.0TFBCF	66.0	10.0	IN48-75X3.0TFBCF	BS48SNX	OR69.57X1.78X	3.22
3	75X5.0	F37-348-75X5.0TFBCF	62.0	10.0	IN48-75X5.0TFBCF	BS48SNX	OR63.22X1.78X	3.38
3	90X3.5	F37-348-90X3.5TFBCF	72.0	15.0	IN48-90X3.5TFBCF	BS48SNX	OR82.27X1.78X	3.39
3	90X5.0	F37-348-90X5.0TFBCF	72.0	14.0	IN48-90X5.0TFBCF	BS48SNX	OR79X1.78X	3.35

Other sizes on request. *Incl. adapter sleeve or jump size flange if necessary.

Please change suffixes according to material/surface required

Order code suffixes		
Material	Suffix surface and material	Example
Steel, zinc plated, Cr(VI)-free	CF	F37-324-50X5.0TFBCF
Stainless steel	SS	F37-324-50X5.0TFBSS

TFV – Flare flange connection

Tube to port connection, F37 seal

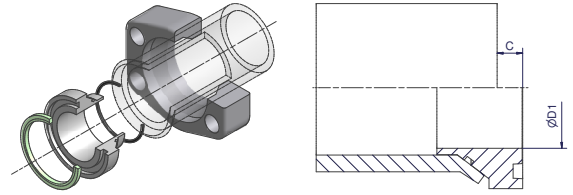

Size		Flange* incl. Insert + F37 Seal + O-Ring Order code	D1	C	Insert incl. F37 Seal + O-Ring Order code	F37 Seal Order code	O-Ring Order code	Weight (Steel) kg/1 kit
Inch	Tube							
1/2	16X2.0	F37-308-16X2.0TFVCF	9.5	8.0	IN08-16X2.0TFVCF	F37S08X	OR12X1.0X	0.24
1/2	18X2.0	F37-308-18X2.0TFVCF	11.5	8.0	IN08-18X2.0TFVCF	F37S08X	OR14X1.0X	0.24
1/2	20X2.0	F37-308-20X2.0TFVCF	13.5	8.0	IN08-20X2.0TFVCF	F37S08X	OR16X1.0X	0.24
1/2	20X2.5	F37-308-20X2.5TFVCF	13.5	8.0	IN08-20X2.5TFVCF	F37S08X	OR16X1.0X	0.24
1/2	25X2.5	F37-308-25X2.5TFVCF	13.5	10.0	IN08-25X2.5TFVCF	F37S08X	OR20X1.0X	0.25
1/2	25X3.0	F37-308-25X3.0TFVCF	13.0	8.0	IN08-25X3.0TFVCF	F37S08X	OR20X1.0X	0.24
3/4	20X2.0	F37-312-20X2.0TFVCF	13.5	8.0	IN12-20X2.0TFVCF	F37S12X	OR16X1.0X	0.31
3/4	20X2.5	F37-312-20X2.5TFVCF	12.5	8.0	IN12-20X2.5TFVCF	F37S12X	OR16X1.0X	0.31
3/4	25X2.5	F37-312-25X2.5TFVCF	17.5	10.0	IN12-25X2.5TFVCF	F37S12X	OR20X1.0X	0.31
3/4	25X3.0	F37-312-25X3.0TFVCF	16.5	8.0	IN12-25X3.0TFVCF	F37S12X	OR20X1.0X	0.32
3/4	30X3.0	F37-312-30X3.0TFVCF	19.0	8.5	IN12-30X3.0TFVCF	F37S12X	OR25X1.0X	0.32
3/4	30X4.0	F37-312-30X4.0TFVCF	19.0	8.5	IN12-30X4.0TFVCF	F37S12X	OR22X1.0X	0.32
1	25X2.5	F37-316-25X2.5TFVCF	17.5	10.0	IN16-25X2.5TFVCF	F37S16X	OR20X1.0X	0.38
1	25X3.0	F37-316-25X3.0TFVCF	16.5	8.0	IN16-25X3.0TFVCF	F37S16X	OR20X1.0X	0.39
1	30X3.0	F37-316-30X3.0TFVCF	21.5	8.5	IN16-30X3.0TFVCF	F37S16X	OR25X1.0X	0.41
1	30X4.0	F37-316-30X4.0TFVCF	19.5	8.5	IN16-30X4.0TFVCF	F37S16X	OR22X1.0X	0.39
1	38X2.5	F37-316-38X2.5TFVCF	25.0	9.5	IN16-38X2.5TFVCF	F37S16X	OR34X1.0X	0.41
1	38X3.0	F37-316-38X3.0TFVCF	25.0	9.0	IN16-38X3.0TFVCF	F37S16X	OR34X1.0X	0.40
1	38X4.0	F37-316-38X4.0TFVCF	25.0	10.0	IN16-38X4.0TFVCF	F37S16X	OR30X1.0X	0.40
1	38X5.0	F37-316-38X5.0TFVCF	25.0	8.0	IN16-38X5.0TFVCF	F37S16X	OR28X1.0X	0.39
1 1/4	30X3.0	F37-320-30X3.0TFVCF	21.5	8.5	IN20-30X3.0TFVCF	F37S20X	OR25X1.0X	0.57
1 1/4	30X4.0	F37-320-30X4.0TFVCF	19.5	8.5	IN20-30X4.0TFVCF	F37S20X	OR22X1.0X	0.58
1 1/4	38X3.0	F37-320-38X3.0TFVCF	29.5	9.0	IN20-38X3.0TFVCF	F37S20X	OR34X1.0X	0.56
1 1/4	38X4.0	F37-320-38X4.0TFVCF	27.0	10.0	IN20-38X4.0TFVCF	F37S20X	OR30X1.0X	0.57
1 1/4	38X5.0	F37-320-38X5.0TFVCF	25.5	8.0	IN20-38X5.0TFVCF	F37S20X	OR28X1.0X	0.56
1 1/4	42X3.0	F37-320-42X3.0TFVCF	31.5	10.0	IN20-42X3.0TFVCF	F37S20X	OR37.82X1.78X	0.57
1 1/4	42X4.0	F37-320-42X4.0TFVCF	31.5	10.0	IN20-42X4.0TFVCF	F37S20X	OR34X1.0X	0.56
1 1/2	38X3.0	F37-324-38X3.0TFVCF	27.5	9.0	IN24-38X3.0TFVCF	F37S24X	OR34X1.0X	0.87
1 1/2	38X4.0	F37-324-38X4.0TFVCF	27.5	10.0	IN24-38X4.0TFVCF	F37S24X	OR30X1.0X	0.87
1 1/2	38X5.0	F37-324-38X5.0TFVCF	25.0	11.0	IN24-38X5.0TFVCF	F37S24X	OR41X1.78X	0.87
1 1/2	42X3.0	F37-324-42X3.0TFVCF	33.5	10.0	IN24-42X3.0TFVCF	F37S24X	OR37.82X1.78X	0.87
1 1/2	42X4.0	F37-324-42X4.0TFVCF	31.5	10.0	IN24-42X4.0TFVCF	F37S24X	OR34X1.0X	0.87
1 1/2	50X3.0	F37-324-50X3.0TFVCF	36.0	11.0	IN24-50X3.0TFVCF	F37S24X	OR44.17X1.78X	0.87
1 1/2	50X5.0	F37-324-50X5.0TFVCF	36.0	10.0	IN24-50X5.0TFVCF	F37S24X	OR41X1.78X	0.87
1 1/2	50X6.0	F37-324-50X6.0TFVCF	35.0	10.0	IN24-50X6.0TFVCF	F37S24X	OR41X1.78X	0.87
2	50X3.0	F37-332-50X3.0TFVCF	41.5	11.0	IN32-50X3.0TFVCF	F37S32X	OR44.17X1.78X	1.20
2	50X5.0	F37-332-50X5.0TFVCF	37.5	10.0	IN32-50X5.0TFVCF	F37S32X	OR41X1.78X	1.22
2	50X6.0	F37-332-50X6.0TFVCF	35.0	10.0	IN32-50X6.0TFVCF	F37S32X	OR41X1.78X	1.25
2	60X3.0	F37-332-60X3.0TFVCF	46.0	12.0	IN32-60X3.0TFVCF	F37S32X	OR53.7X1.78X	1.25
2	60X5.0	F37-332-60X5.0TFVCF	46.0	11.0	IN32-60X5.0TFVCF	F37S32X	OR50.52X1.78X	1.22
2	60X6.0	F37-332-60X6.0TFVCF	45.5	11.0	IN32-60X6.0TFVCF	F37S32X	OR47.37X1.78X	1.21
2 1/2	60X3.0	F37-340-60X3.0TFVCF	50.0	12.0	IN40-60X3.0TFVCF	F37S40X	OR53.7X1.78X	1.98
2 1/2	60X5.0	F37-340-60X5.0TFVCF	46.0	11.0	IN40-60X5.0TFVCF	F37S40X	OR50.52X1.78X	1.99
2 1/2	60X6.0	F37-340-60X6.0TFVCF	45.5	11.0	IN40-60X6.0TFVCF	F37S40X	OR47.37X1.78X	1.97
2 1/2	75X3.0	F37-340-75X3.0TFVCF	60.0	10.0	IN40-75X3.0TFVCF	F37S40X	OR69.57X1.78X	1.93
2 1/2	75X5.0	F37-340-75X5.0TFVCF	60.0	10.0	IN40-75X5.0TFVCF	F37S40X	OR63.22X1.78X	1.95
3	75X3.0	F37-348-75X3.0TFVCF	66.0	10.0	IN48-75X3.0TFVCF	F37S48X	OR69.57X1.78X	3.22
3	75X5.0	F37-348-75X5.0TFVCF	62.0	10.0	IN48-75X5.0TFVCF	F37S48X	OR63.22X1.78X	3.38
3	90X3.5	F37-348-90X3.5TFVCF	72.0	15.0	IN48-90X3.5TFVCF	F37S48X	OR82.27X1.78X	3.39
3	90X5.0	F37-348-90X5.0TFVCF	72.0	14.0	IN48-90X5.0TFVCF	F37S48X	OR79X1.78X	3.35

Other sizes on request. *Incl. adapter sleeve or jump size flange if necessary.

Please change suffixes according to material/surface required

Order code suffixes		
Material	Suffix surface and material	Example
Steel, zinc plated, Cr(VI)-free	CF	F37-324-50X5.0TFVCF
Stainless steel	SS	F37-324-50X5.0TFVSS



TT - Flare flange connection

Tube to tube connection

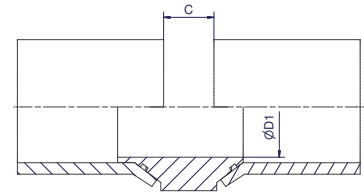
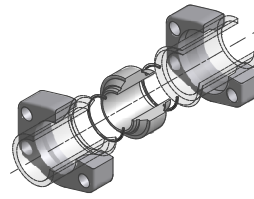

Size		2 Flanges* incl. Insert + 2 x O-Ring Order code	D1	C	Insert incl. 2 x O-Ring Order code	O-Ring Order code	Weight (Steel) kg/1 kit
Inch	Tube						
1/2	16X2.0	F37-308-16X2.0TTCF	9.5	16	IN08-16X2.0TTCF	OR12X1.0X	0.28
1/2	18X2.0	F37-308-18X2.0TTCF	11.5	16	IN08-18X2.0TTCF	OR14X1.0X	0.29
1/2	20X2.0	F37-308-20X2.0TTCF	13.5	16	IN08-20X2.0TTCF	OR16X1.0X	0.29
1/2	20X2.5	F37-308-20X2.5TTCF	13.5	16	IN08-20X2.5TTCF	OR16X1.0X	0.29
1/2	25X2.5	F37-308-25X2.5TTCF	13.5	20	IN08-25X2.5TTCF	OR20X1.0X	0.30
1/2	25X3.0	F37-308-25X3.0TTCF	13.0	16	IN08-25X3.0TTCF	OR20X1.0X	0.29
3/4	20X2.0	F37-312-20X2.0TTCF	13.5	16	IN12-20X2.0TTCF	OR16X1.0X	0.38
3/4	20X2.5	F37-312-20X2.5TTCF	12.5	16	IN12-20X2.5TTCF	OR16X1.0X	0.38
3/4	25X2.5	F37-312-25X2.5TTCF	17.5	20	IN12-25X2.5TTCF	OR20X1.0X	0.39
3/4	25X3.0	F37-312-25X3.0TTCF	16.5	16	IN12-25X3.0TTCF	OR20X1.0X	0.39
3/4	30X3.0	F37-312-30X3.0TTCF	19.0	17	IN12-30X3.0TTCF	OR25X1.0X	0.40
3/4	30X4.0	F37-312-30X4.0TTCF	19.0	17	IN12-30X4.0TTCF	OR22X1.0X	0.40
1	25X2.5	F37-316-25X2.5TTCF	17.5	20	IN16-25X2.5TTCF	OR20X1.0X	0.49
1	25X3.0	F37-316-25X3.0TTCF	16.5	16	IN16-25X3.0TTCF	OR20X1.0X	0.49
1	30X3.0	F37-316-30X3.0TTCF	21.5	17	IN16-30X3.0TTCF	OR25X1.0X	0.48
1	30X4.0	F37-316-30X4.0TTCF	19.5	17	IN16-30X4.0TTCF	OR22X1.0X	0.49
1	38X2.5	F37-316-38X2.5TTCF	25.0	19	IN16-38X2.5TTCF	OR34X1.0X	0.54
1	38X3.0	F37-316-38X3.0TTCF	25.0	18	IN16-38X3.0TTCF	OR34X1.0X	0.52
1	38X4.0	F37-316-38X4.0TTCF	25.0	20	IN16-38X4.0TTCF	OR30X1.0X	0.50
1	38X5.0	F37-316-38X5.0TTCF	25.0	16	IN16-38X5.0TTCF	OR28X1.0X	0.48
1 1/4	30X3.0	F37-320-30X3.0TTCF	21.5	17	IN20-30X3.0TTCF	OR25X1.0X	0.70
1 1/4	30X4.0	F37-320-30X4.0TTCF	19.5	17	IN20-30X4.0TTCF	OR22X1.0X	0.73
1 1/4	38X3.0	F37-320-38X3.0TTCF	29.0	18	IN20-38X3.0TTCF	OR34X1.0X	0.68
1 1/4	38X4.0	F37-320-38X4.0TTCF	27.0	20	IN20-38X4.0TTCF	OR30X1.0X	0.69
1 1/4	38X5.0	F37-320-38X5.0TTCF	25.5	16	IN20-38X5.0TTCF	OR28X1.0X	0.67
1 1/4	42X3.0	F37-320-42X3.0TTCF	31.5	20	IN20-42X3.0TTCF	OR37.82X1.78X	0.68
1 1/4	42X4.0	F37-320-42X4.0TTCF	31.5	20	IN20-42X4.0TTCF	OR34X1.0X	0.67
1 1/2	38X3.0	F37-324-38X3.0TTCF	27.5	18	IN24-38X3.0TTCF	OR34X1.0X	0.93
1 1/2	38X4.0	F37-324-38X4.0TTCF	27.5	20	IN24-38X4.0TTCF	OR30.X1.0X	0.93
1 1/2	38X5.0	F37-324-38X5.0TTCF	25.0	22	IN24-38X5.0TTCF	OR41X1.78X	0.93
1 1/2	42X3.0	F37-324-42X3.0TTCF	33.5	20	IN24-42X3.0TTCF	OR37.82X1.78X	0.98
1 1/2	42X4.0	F37-324-42X4.0TTCF	31.5	20	IN24-42X4.0TTCF	OR34X1.0X	1.08
1 1/2	50X3.0	F37-324-50X3.0TTCF	36.0	22	IN24-50X3.0TTCF	OR44.17X1.78X	1.10
1 1/2	50X5.0	F37-324-50X5.0TTCF	36.0	20	IN24-50X5.0TTCF	OR41X1.78X	1.21
1 1/2	50X6.0	F37-324-50X6.0TTCF	35.0	20	IN24-50X6.0TTCF	OR41X1.78X	1.10
2	50X3.0	F37-332-50X3.0TTCF	41.5	22	IN32-50X3.0TTCF	OR44.17X1.78X	1.40
2	50X5.0	F37-332-50X5.0TTCF	37.5	20	IN32-50X5.0TTCF	OR41X1.78X	1.51
2	50X6.0	F37-332-50X6.0TTCF	35.0	20	IN32-50X6.0TTCF	OR41X1.78X	1.56
2	60X3.0	F37-332-60X3.0TTCF	46.0	24	IN32-60X3.0TTCF	OR53.7X1.78X	1.53
2	60X5.0	F37-332-60X5.0TTCF	46.0	22	IN32-60X5.0TTCF	OR50.52X1.78X	1.46
2	60X6.0	F37-332-60X6.0TTCF	45.5	22	IN32-60X6.0TTCF	OR47.37X1.78X	1.45
2 1/2	60X3.0	F37-340-60X3.0TTCF	50.0	24	IN40-60X3.0TTCF	OR53.7X1.78X	1.98
2 1/2	60X5.0	F37-340-60X5.0TTCF	46.0	22	IN40-60X5.0TTCF	OR50.52X1.78X	1.99
2 1/2	60X6.0	F37-340-60X6.0TTCF	45.0	22	IN40-60X6.0TTCF	OR47.37X1.78X	1.97
2 1/2	75X3.0	F37-340-75X3.0TTCF	60.0	20	IN40-75X3.0TTCF	OR69.57X1.78X	1.93
2 1/2	75X5.0	F37-340-75X5.0TTCF	60.0	20	IN40-75X5.0TTCF	OR63.22X1.78X	1.95
3	75X3.0	F37-348-75X3.0TTCF	66.0	20	IN48-75X3.0TTCF	OR69.57X1.78X	3.22
3	75X5.0	F37-348-75X5.0TTCF	62.0	20	IN48-75X5.0TTCF	OR63.22X1.78X	3.38
3	90X3.5	F37-348-90X3.5TTCF	72.0	30	IN48-90X3.5TTCF	OR82.27X1.78X	3.39
3	90X5.0	F37-348-90X5.0TTCF	72.0	28	IN48-90X5.0TTCF	OR79X1.78X	3.35

Other sizes on request. *Incl. adapter sleeve or jump size flange if necessary.

Please change suffixes according to material/surface required

Order code suffixes		
Material	Suffix surface and material	Example
Steel, zinc plated, Cr(VI)-free	CF	F37-324-50X5.0TTCF
Stainless steel	SS	F37-324-50X5.0TTSS

TF – Flare flange connection

Tube to flange connection, flat face

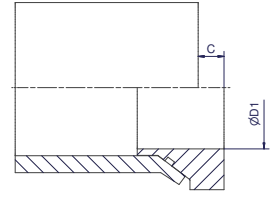
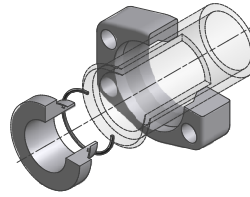

Size		Flange* incl. Insert + O-Ring Order code	D1	C	Insert incl. O-Ring Order code	O-Ring Order code	Weight (Steel) kg/1 kit
Inch	Tube						
1/2	16X2.0	F37-308-16X2.0TFCF	9.5	8.0	IN08-16X2.0TFCF	OR12X1.0X	0.24
1/2	18X2.0	F37-308-18X2.0TFCF	11.5	8.0	IN08-18X2.0TFCF	OR14X1.0X	0.24
1/2	20X2.0	F37-308-20X2.0TFCF	13.5	8.0	IN08-20X2.0TFCF	OR16X1.0X	0.25
1/2	20X2.5	F37-308-20X2.5TFCF	13.5	8.0	IN08-20X2.5TFCF	OR16X1.0X	0.25
1/2	25X2.5	F37-308-25X2.5TFCF	13.5	10.0	IN08-25X2.5TFCF	OR20X1.0X	0.25
1/2	25X3.0	F37-308-25X3.0TFCF	13.0	8.0	IN08-25X3.0TFCF	OR20X1.0X	0.24
3/4	20X2.0	F37-312-20X2.0TFCF	13.5	8.0	IN12-20X2.0TFCF	OR16X1.0X	0.31
3/4	20X2.5	F37-312-20X2.5TFCF	12.5	8.0	IN12-20X2.5TFCF	OR16X1.0X	0.31
3/4	25X2.5	F37-312-25X2.5TFCF	17.5	10.0	IN12-25X2.5TFCF	OR20X1.0X	0.31
3/4	25X3.0	F37-312-25X3.0TFCF	16.5	8.0	IN12-25X3.0TFCF	OR20X1.0X	0.32
3/4	30X3.0	F37-312-30X3.0TFCF	19.0	8.5	IN12-30X3.0TFCF	OR25X1.0X	0.32
3/4	30X4.0	F37-312-30x4.0TFCF	19.0	8.5	IN12-30x4.0TFCF	OR22X1.0X	0.32
1	25X2.5	F37-316-25X2.5TFCF	17.5	10.0	IN16-25X2.5TFCF	OR20X1.0X	0.38
1	25X3.0	F37-316-25X3.0TFCF	16.5	8.0	IN16-25X3.0TFCF	OR20X1.0X	0.39
1	30X3.0	F37-316-30X3.0TFCF	21.5	8.5	IN16-30X3.0TFCF	OR25X1.0X	0.41
1	30X4.0	F37-316-30X4.0TFCF	19.5	8.5	IN16-30X4.0TFCF	OR22X1.0X	0.39
1	38X2.5	F37-316-38X2.5TFCF	25.0	9.5	IN16-38X2.5TFCF	OR34X1.0X	0.41
1	38X3.0	F37-316-38X3.0TFCF	25.0	9.0	IN16-38X3.0TFCF	OR34X1.0X	0.40
1	38X4.0	F37-316-38X4.0TFCF	25.0	10.0	IN16-38X4.0TFCF	OR30X1.0X	0.40
1	38X5.0	F37-316-38X5.0TFCF	25.0	8.0	IN16-38X5.0TFCF	OR28X1.0X	0.39
1 1/4	30X3.0	F37-320-30X3.0TFCF	21.5	8.5	IN20-30X3.0TFCF	OR25X1.0X	0.57
1 1/4	30X4.0	F37-320-30X4.0TFCF	19.5	8.5	IN20-30X4.0TFCF	OR22X1.0X	0.59
1 1/4	38X3.0	F37-320-38X3.0TFCF	29.0	9.0	IN20-38X3.0TFCF	OR34X1.0X	0.56
1 1/4	38X4.0	F37-320-38X4.0TFCF	27.0	10.0	IN20-38X4.0TFCF	OR30X1.0X	0.57
1 1/4	38X5.0	F37-320-38X5.0TFCF	25.5	8.0	IN20-38X5.0TFCF	OR28X1.0X	0.56
1 1/4	42X3.0	F37-320-42X3.0TFCF	31.5	10.0	IN20-42X3.0TFCF	OR37.82X1.78X	0.57
1 1/4	42X4.0	F37-320-42X4.0TFCF	31.5	10.0	IN20-42X4.0TFCF	OR34X1.0X	0.56
1 1/2	38X3.0	F37-324-38X3.0TFCF	27.5	9.0	IN24-38X3.0TFCF	OR34X1.0X	0.87
1 1/2	38X4.0	F37-324-38X4.0TFCF	27.5	10.0	IN24-38X4.0TFCF	OR30X1.0X	0.87
1 1/2	38X5.0	F37-324-38X5.0TFCF	25.0	11.0	IN24-38X5.0TFCF	OR41X1.78X	0.87
1 1/2	42X3.0	F37-324-42X3.0TFCF	33.5	10.0	IN24-42X3.0TFCF	OR37.82X1.78X	0.87
1 1/2	42X4.0	F37-324-42X4.0TFCF	31.5	10.0	IN24-42X4.0TFCF	OR34X1.0X	0.87
1 1/2	50X3.0	F37-324-50X3.0TFCF	36.0	11.0	IN24-50X3.0TFCF	OR44.17X1.78X	0.87
1 1/2	50X5.0	F37-324-50X5.0TFCF	36.0	10.0	IN24-50X5.0TFCF	OR41X1.78X	0.87
1 1/2	50X6.0	F37-324-50X6.0TFCF	35.0	10.0	IN24-50X6.0TFCF	OR41X1.78X	0.87
2	50X3.0	F37-332-50X3.0TFCF	41.5	11.0	IN32-50X3.0TFCF	OR44.17X1.78X	1.20
2	50X5.0	F37-332-50X5.0TFCF	37.5	10.0	IN32-50X5.0TFCF	OR41X1.78X	1.22
2	50X6.0	F37-332-50X6.0TFCF	35.0	10.0	IN32-50X6.0TFCF	OR41X1.78X	1.25
2	60X3.0	F37-332-60X3.0TFCF	46.0	12.0	IN32-60X3.0TFCF	OR53.7X1.78X	1.25
2	60X5.0	F37-332-60X5.0TFCF	46.0	11.0	IN32-60X5.0TFCF	OR50.52X1.78X	1.22
2	60X6.0	F37-332-60X6.0TFCF	45.5	11.0	IN32-60X6.0TFCF	OR47.37X1.78X	1.21
2 1/2	60X3.0	F37-340-60X3.0TFCF	50.0	12.0	IN40-60X3.0TFCF	OR53.7X1.78X	1.98
2 1/2	60X5.0	F37-340-60X5.0TFCF	46.0	11.0	IN40-60X5.0TFCF	OR50.52X1.78X	1.99
2 1/2	60X6.0	F37-340-60X6.0TFCF	45.5	11.0	IN40-60X6.0TFCF	OR47.37X1.78X	1.97
2 1/2	75X3.0	F37-340-75X3.0TFCF	60.0	10.0	IN40-75X3.0TFCF	OR69.57X1.78X	1.93
2 1/2	75X5.0	F37-340-75X5.0TFCF	60.0	10.0	IN40-75X5.0TFCF	OR63.22X1.78X	1.95
3	75X3.0	F37-348-75X3.0TFCF	66.0	10.0	IN48-75X3.0TFCF	OR69.57X1.78X	3.22
3	75X5.0	F37-348-75X5.0TFCF	62.0	10.0	IN48-75X5.0TFCF	OR63.22X1.78X	3.38
3	90X3.5	F37-348-90X3.5TFCF	72.0	15.0	IN48-90X3.5TFCF	OR82.27X1.78X	3.39
3	90X5.0	F37-348-90X5.0TFCF	72.0	14.0	IN48-90X5.0TFCF	OR79X1.78X	3.35

Other sizes on request. *Incl. adapter sleeve or jump size flange if necessary.

Please change suffixes according to material/surface required

Order code suffixes		
Material	Suffix surface and material	Example
Steel, zinc plated, Cr(VI)-free	CF	F37-324-50X5.0TFCF
Stainless steel	SS	F37-324-50X5.0TFSS



SL – Sleeve

SAE 3000/ISO 6162-1

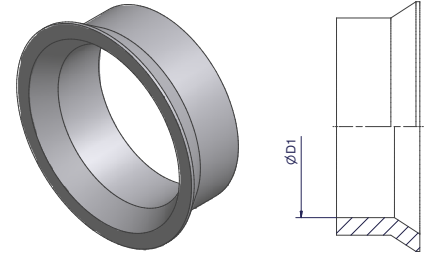

Size Inch	Tube OD	Order code	D1	Weight body (Steel) kg/1 piece
1/2	16	SL08-25-16-CFX*	16.30	0.04
1/2	18	SL08-25-18-CFX	18.30	0.04
1/2	20	SL08-25-20-CFX*	20.30	0.04
3/4	20	SL12-30-20-CFX	20.30	0.04
3/4	25	SL12-30-25-CFX	25.20	0.04
1	25	SL16-38-25-CFX*	25.20	0.04
1	30	SL16-38-30-CFX*	30.20	0.04
1 1/4	30	SL20-42-30-CFX	30.20	0.04
1 1/4	38	SL20-42-38-CFX*	38.25	0.04
1 1/2	38	SL24-50-38-CFX	38.25	0.14
1 1/2	42	SL24-50-42-CFX*	42.30	0.10
2	50	SL32-60-50-CFX	50.30	0.16
2 1/2	60	SL40-75-60-CFX	60.45	0.36
3	75	SL48-90-75-CFX	75.45	0.52

*By use of jump size flanges, no adapter sleeves necessary. For jump size flanges see page 61.

Please change suffixes according to material/surface required

Order code suffixes		
Material	Suffix surface and material	Example
Steel, zinc plated, Cr(VI)-free	CF	SL24-50-42-CFX
Stainless steel	SS	SL24-50-42-SSX

R – Retaining ring

SAE 3000/ISO 6162-1

Size Inch	Tube	Order code	D	S
1/2	26X6.0	R08X	22.3	4.0
3/4	36X8.0	R12X	32.3	4.0
1	39X7.5	R16X	34.3	5.0
1 1/4	46X8.0	R20X	41.3	5.0
1 1/2	56X8.5	R24X	51.3	5.0
2	66X8.5	R32X	61.3	5.0
2 1/2	80X10.0	R40X	75.3	5.0
3	97X12.0	R48X	91.3	6.0

Material: Stainless steel

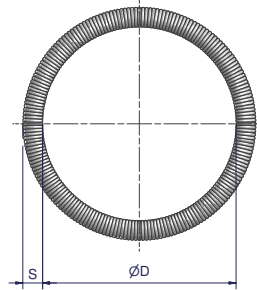

MTF-R – Male thread adapter, BSPP

SAE 3000/ISO 6162-1

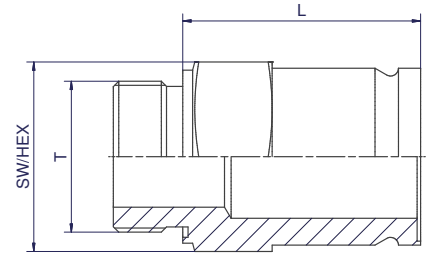
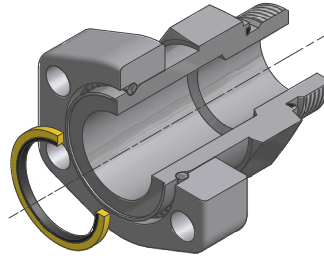

Size Inch	Tube	Complete part Order code	Body incl. ED Seal Order code	L	T (BSPP)	SW/ HEX	Weight body (Steel) kg/1 piece
1/2	26X6.0	R-308MTFRCF	MTF08ROMDCF	61.0	G 1/2A	27	0.21
3/4	36X8.0	R-312MTFRCF	MTF12ROMDCF	61.0	G 3/4A	36	0.32
3/4	36X8.0	R-312MTFR1/2CF	MTF12R1/2OMDCF	61.0	G 1/2A	36	0.32
1	39X7.5	R-316MTFRCF	MTF16ROMDCF	69.0	G 1A	41	0.50
1	39X7.5	R-316MTFR3/4CF	MTF16R3/4OMDCF	69.0	G 3/4A	41	0.50
1 1/4	46X8.0	R-320MTFRCF	MTF20ROMDCF	80.0	G 1 1/4A	50	0.75
1 1/4	46X8.0	R-320MTFR1CF	MTF20R1OMDCF	80.0	G 1A	50	0.73
1 1/2	56X8.5	R-324MTFRCF	MTF24ROMDCF	93.0	G 1 1/2A	60	1.20
1 1/2	56X8.5	R-324MTFR11/4CF	MTF24R11/4OMDCF	93.0	G 1 1/4A	60	1.17
2	66X8.5	R-332MTFRCF	MTF32ROMDCF	104.0	G 2A	75	1.87
2	66X8.5	R-332MTFR11/2CF	MTF32R11/2OMDCF	103.5	G 1 1/2A	75	1.80
2 1/2	80X10.0	R-340MTFRCF	MTF40ROMDCF	134.0	G 2 1/2A	85	3.50
2 1/2	80X10.0	R-340MTFR2CF	MTF40R2OMDCF	136.0	G 2A	85	3.50
3	97X12.0	R-348MTFRCF	MTF48ROMDCF	145.0	G 3A	95	5.00

Other sizes on request.

Please change suffixes according to material/surface required

Order code suffixes		
Material	Suffix surface and material	Example
Steel, zinc plated, Cr(VI)-free	CF	R-320MTFRCF
Stainless steel	SS	R-320MTFRSS

MTF-N – Male thread adapter, NPT

SAE 3000/ISO 6162-1

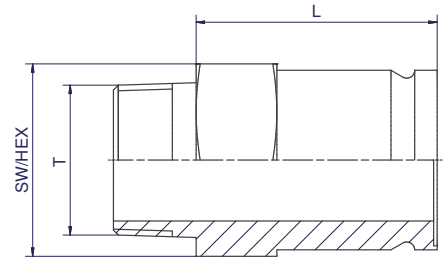
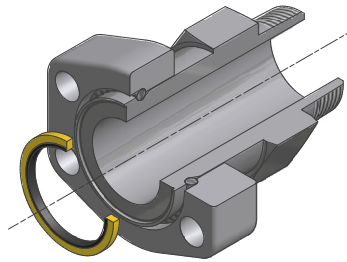

Size Inch	Tube	Complete part Order code	Body Order code	L	T (NPT)	SW/HEX	Weight body (Steel) kg/1 piece
1/2	26X6.0	R-308MTFNCF	MTF08NCFX	92.0	1/2-14	27	0.26
3/4	36X8.0	R-312MTFNCF	MTF12NCFX	72.6	3/4-14	36	0.48
1	39X7.5	R-316MTFNCF	MTF16NCFX	67.7	1-11.5	41	0.55
1 1/4	46X8.0	R-320MTFNCF	MTF20NCFX	75.0	1 1/4-11.5	50	0.70
1 1/2	56X8.5	R-324MTFNCF	MTF24NCFX	93.2	1 1/2-11.5	60	1.80
2	66X8.5	R-332MTFNCF	MTF32NCFX	100.4	2-11.5	75	2.40
2 1/2	80X10.0	R-340MTFNCF	MTF40NCFX	130.0	2 1/2-8	85	3.40
3	97X12.0	R-348MTFNCF	MTF48NCFX	141.2	3-8	95	4.90

Other sizes on request.

Please change suffixes according to material/surface required

Order code suffixes		
Material	Suffix surface and material	Example
Steel, zinc plated, Cr(VI)-free	CF	R-320MTFNCF
Stainless steel	SS	R-320MTFNSS



FTF-R – Female thread adapter, BSPP

SAE 3000/ISO 6162-1

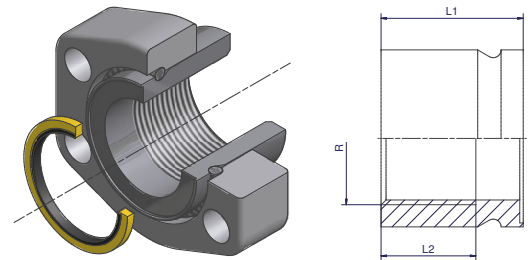

Size Inch	Tube	Complete part Order code	Body Order code	L1	L2	R (BSPP)	Weight body (Steel) kg/1 piece
1/2	26X6.0	R-308FTFRCF	FTF08RCFX	35	25	G 1/4	0.11
3/4	36X8.0	R-312FTFRCF	FTF12RCFX	40	25	G 1/2	0.22
1	39X7.5	R-316FTFRCF	FTF16RCFX	40	25	G 3/4	0.20
1 1/4	46X8.0	R-320FTFRCF	FTF20RCFX	42	30	G 1	0.30
1 1/2	56X8.5	R-324FTFRCF	FTF24RCFX	45	30	G 1 1/4	0.45
2	66X8.5	R-332FTFRCF	FTF32RCFX	55	40	G 1 1/2	0.75
2 1/2	80X10.0	R-340FTFRCF	FTF40RCFX	80	40	G 2	1.52
3	97X12.0	R-348FTFRCF	FTF48RCFX	85	50	G 2 1/2	2.11

Other sizes on request.

Please change suffixes according to material/surface required

Order code suffixes		
Material	Suffix surface and material	Example
Steel, zinc plated, Cr(VI)-free	CF	R-320FTFRCF
Stainless steel	SS	R-320FTFRSS

Retaining ring hose couplings

SAE 3000/ISO 6162-1 or ISO 6162-2

X5 and K5 Flange - Straight

Full flange system for ISO 6162-1 or ISO 6162-2

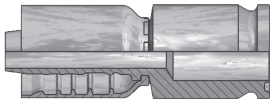

1X577-...



KX5V6-...

X7 and K7 Flange - 45° Elbow

Full flange system for ISO 6162-1 or ISO 6162-2

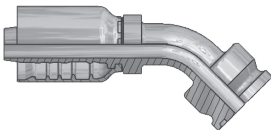

1X777-...



KX7V6-...

X9 and K9 Flange - 90° Elbow

Full flange system for ISO 6162-1 or ISO 6162-2

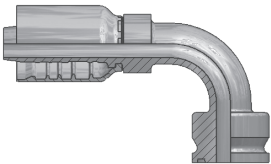

1X977-...

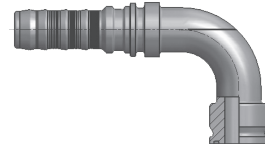

KX9V6-...

Details about hose fittings and the associated hose types can be found in the catalog of PHDE CAT/4400/UK.

WA – Weld adapter connection

SAE 3000/ISO 6162-1

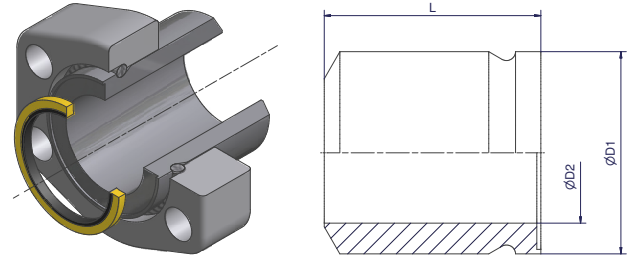

Size Inch	Tube	Complete Part Order code	Retaining Ring	Bonded Seal	Flange Order code	Weld Adapter Body Order code	D1	D2	L	Weight (Steel) kg/1 kit
1/2	12X1.5	R-308WA-12X1.5S	R08X	BS08SNX	R-308-CFX	WA08-12X1.5SX	26	9	40	0.29
1/2	16X2.0	R-308WA-16X2.0S	R08X	BS08SNX	R-308-CFX	WA08-16X2.0SX	26	12	40	0.30
1/2	18X2.0	R-308WA-18X2.0S	R08X	BS08SNX	R-308-CFX	WA08-18X2.0SX	26	14	40	0.30
1/2	20X2.5	R-308WA-20X2.5S	R08X	BS08SNX	R-308-CFX	WA08-20X2.5SX	26	15	40	0.30
1/2	21.3X2.1	R-308WA-21.3X2.1S	R08X	BS08SNX	R-308-CFX	WA08-21.3X2.1SX	26	17	40	0.30
1/2	21.3X2.8	R-308WA-21.3X2.8S	R08X	BS08SNX	R-308-CFX	WA08-21.3X2.8SX	26	16	40	0.30
1/2	21.3X3.7	R-308WA-21.3X3.7S	R08X	BS08SNX	R-308-CFX	WA08-21.3X3.7SX	26	14	45	0.31
1/2	21.3X4.8	R-308WA-21.3X4.8S	R08X	BS08SNX	R-308-CFX	WA08-21.3X4.8SX	26	12	45	0.32
1/2	21.3X7.5	R-308WA-21.3X7.5S	R08X	BS08SNX	R-308-CFX	WA08-21.3X7.5SX	26	6	45	0.32
1/2	25X2.5	R-308WA-25X2.5S	R08X	BS08SNX	R-308-CFX	WA08-25X2.5SX	26	14	40	0.29
1/2	26X6.0	R-308WA-26X6.0S	R08X	BS08SNX	R-308-CFX	WA08-26X6.0SX	26	14	40	0.31
3/4	20X2.5	R-312WA-20X2.5S	R12X	BS12SNX	R-312-CFX	WA12-20X2.5SX	36	15	45	0.41
3/4	25X3.0	R-312WA-25X3.0S	R12X	BS12SNX	R-312-CFX	WA12-25X3.0SX	36	19	45	0.41
3/4	26.7X2.1	R-312WA-26.7X2.1S	R12X	BS12SNX	R-312-CFX	WA12-26.7X2.1SX	36	20	45	0.40
3/4	26.7X2.8	R-312WA-26.7X2.8S	R12X	BS12SNX	R-312-CFX	WA12-26.7X2.8SX	36	20	45	0.41
3/4	26.7X3.9	R-312WA-26.7X3.9S	R12X	BS12SNX	R-312-CFX	WA12-26.7X3.9SX	36	19	45	0.41
3/4	26.7X5.6	R-312WA-26.7X5.6S	R12X	BS12SNX	R-312-CFX	WA12-26.7X5.6SX	36	16	50	0.44
3/4	26.7X7.8	R-312WA-26.7X7.8S	R12X	BS12SNX	R-312-CFX	WA12-26.7X7.8SX	36	11	50	0.45
3/4	30X3.0	R-312WA-30X3.0S	R12X	BS12SNX	R-312-CFX	WA12-30X3.0SX	36	20	50	0.41
3/4	30X4.0	R-312WA-30X4.0S	R12X	BS12SNX	R-312-CFX	WA12-30X4.0SX	36	20	50	0.42
3/4	30X6.0	R-312WA-30X6.0S	R12X	BS12SNX	R-312-CFX	WA12-30X6.0SX	36	18	50	0.44
3/4	30X8.0	R-312WA-30X8.0S	R12X	BS12SNX	R-312-CFX	WA12-30X8.0SX	36	14	50	0.46
1	25X3.0	R-316WA-25X3.0S	R16X	BS16SNX	R-316-CFX	WA16-25X3.0SX	39	19	60	0.61
1	30X4.0	R-316WA-30X4.0S	R16X	BS16SNX	R-316-CFX	WA16-30X4.0SX	39	20	60	0.60
1	33.4X2.8	R-316WA-33.4X2.8S	R16X	BS16SNX	R-316-CFX	WA16-33.4X2.8SX	39	24	60	0.56
1	33.4X3.4	R-316WA-33.4X3.4S	R16X	BS16SNX	R-316-CFX	WA16-33.4X3.4SX	39	24	60	0.57
1	33.4X4.6	R-316WA-33.4X4.6S	R16X	BS16SNX	R-316-CFX	WA16-33.4X4.6SX	39	24	60	0.59
1	33.4X6.5	R-316WA-33.4X6.5S	R16X	BS16SNX	R-316-CFX	WA16-33.4X6.5SX	39	20	60	0.65
1	33.4X9.1	R-316WA-33.4X9.1S	R16X	BS16SNX	R-316-CFX	WA16-33.4X9.1SX	39	15	60	0.64
1	38X4.0	R-316WA-38X4.0S	R16X	BS16SNX	R-316-CFX	WA16-38X4.0SX	39	24	55	0.54
1	38X5.0	R-316WA-38X5.0S	R16X	BS16SNX	R-316-CFX	WA16-38X5.0SX	39	24	55	0.56
1	38X7.0	R-316WA-38X7.0S	R16X	BS16SNX	R-316-CFX	WA16-38X7.0SX	39	24	60	0.62
1	39X7.5	R-316WA-39X7.5S	R16X	BS16SNX	R-316-CFX	WA16-39X7.5SX	39	24	50	0.57
1 1/4	30X4.0	R-320WA-30X4.0S	R20X	BS20SNX	R-320-CFX	WA20-30X4.0SX	46	22	70	1.04
1 1/4	38X4.0	R-320WA-38X4.0S	R20X	BS20SNX	R-320-CFX	WA20-38X4.0SX	46	30	65	0.89
1 1/4	38X5.0	R-320WA-38X5.0S	R20X	BS20SNX	R-320-CFX	WA20-38X5.0SX	46	28	65	0.94
1 1/4	42X3.0	R-320WA-42X3.0S	R20X	BS20SNX	R-320-CFX	WA20-42X3.0SX	46	30	65	0.84
1 1/4	42X4.0	R-320WA-42X4.0S	R20X	BS20SNX	R-320-CFX	WA20-42X4.0SX	46	30	65	0.87
1 1/4	42X6.0	R-320WA-42X6.0S	R20X	BS20SNX	R-320-CFX	WA20-42X6.0SX	46	30	65	0.93
1 1/4	42.2X2.7	R-320WA-42.2X2.7S	R20X	BS20SNX	R-320-CFX	WA20-42.2X2.7SX	46	30	65	0.83
1 1/4	42.2X3.6	R-320WA-42.2X3.6S	R20X	BS20SNX	R-320-CFX	WA20-42.2X3.6SX	46	30	65	0.86
1 1/4	42.2X4.9	R-320WA-42.2X4.9S	R20X	BS20SNX	R-320-CFX	WA20-42.2X4.9SX	46	30	65	0.90
1 1/4	42.2X6.4	R-320WA-42.2X6.4S	R20X	BS20SNX	R-320-CFX	WA20-42.2X6.4SX	46	29	65	0.94
1 1/4	42.2X9.7	R-320WA-42.2X9.7S	R20X	BS20SNX	R-320-CFX	WA20-42.2X9.7SX	46	23	65	1.06
1 1/4	46X7.0	R-320WA-46X7.0S	R20X	BS20SNX	R-320-CFX	WA20-46X7.0SX	46	30	65	0.95
1 1/4	46X8.0	R-320WA-46X8.0S	R20X	BS20SNX	R-320-CFX	WA20-46X8.0SX	46	30	55	0.88
1 1/2	38X5.0	R-324WA-38X5.0S	R24X	BS24SNX	R-324-CFX	WA24-38X5.0SX	56	28	75	1.45
1 1/2	48.3X2.8	R-324WA-48.3X2.8S	R24X	BS24SNX	R-324-CFX	WA24-48.3X2.8SX	56	39	70	1.11
1 1/2	48.3X3.7	R-324WA-48.3X3.7S	R24X	BS24SNX	R-324-CFX	WA24-48.3X3.7SX	56	39	70	1.15
1 1/2	48.3X5.1	R-324WA-48.3X5.1S	R24X	BS24SNX	R-324-CFX	WA24-48.3X5.1SX	56	38	70	1.21

see next page

WA – Weld adapter connection continued

SAE 3000/ISO 6162-1

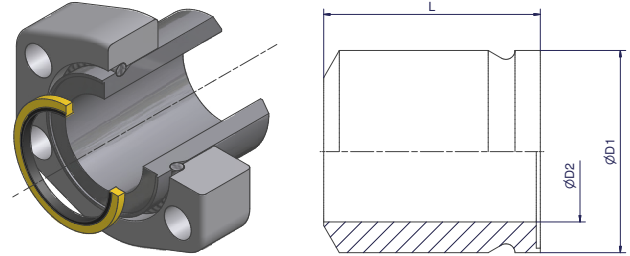

Size Inch	Tube	Complete Part Order code	Retaining Ring	Bonded Seal	Flange Order code	Weld Adapter Body Order code	D1	D2	L	Weight (Steel) kg/1 kit
1 1/2	48.3X7.1	R-324WA-48.3X7.1S	R24X	BS24SNX	R-324-CFX	WA24-48.3X7.1SX	56	34	70	1.33
1 1/2	48.3X10.2	R-324WA-48.3X10.2S	R24X	BS24SNX	R-324-CFX	WA24-48.3X10.2SX	56	28	70	1.29
1 1/2	50X3.0	R-324WA-50X3.0S	R24X	BS24SNX	R-324-CFX	WA24-50X3.0SX	56	39	70	1.10
1 1/2	50X5.0	R-324WA-50X5.0S	R24X	BS24SNX	R-324-CFX	WA24-50X5.0SX	56	40	70	1.17
1 1/2	50X6.0	R-324WA-50X6.0S	R24X	BS24SNX	R-324-CFX	WA24-50X6.0SX	56	38	70	1.23
1 1/2	50X9.0	R-324WA-50X9.0S	R24X	BS24SNX	R-324-CFX	WA24-50X9.0SX	56	32	70	1.39
1 1/2	56X8.5	R-324WA-56X8.5S	R24X	BS24SNX	R-324-CFX	WA24-56X8.5SX	56	39	60	1.15
2	48.3X5.6	R-332WA-48.3X5.6S	R32X	BS32SNX	R-332-CFX	WA32-48.3X5.6SX	66	37	90	2.30
2	50X9.0	R-332WA-50X9.0S	R32X	BS32SNX	R-332-CFX	WA32-50X9.0SX	66	32	90	2.51
2	60X3.0	R-332WA-60X3.0S	R32X	BS32SNX	R-332-CFX	WA32-60X3.0SX	66	49	90	1.79
2	60X5.0	R-332WA-60X5.0S	R32X	BS32SNX	R-332-CFX	WA32-60X5.0SX	66	50	90	1.89
2	60X6.0	R-332WA-60X6.0S	R32X	BS32SNX	R-332-CFX	WA32-60X6.0SX	66	48	90	2.00
2	60X8.0	R-332WA-60X8.0S	R32X	BS32SNX	R-332-CFX	WA32-60X8.0SX	66	44	90	2.18
2	60X10.0	R-332WA-60X10.0S	R32X	BS32SNX	R-332-CFX	WA32-60X10.0SX	66	40	90	2.36
2	60.3X2.8	R-332WA-60.3X2.8S	R32X	BS32SNX	R-332-CFX	WA32-60.3X2.8SX	66	49	90	1.77
2	60.3X3.9	R-332WA-60.3X3.9S	R32X	BS32SNX	R-332-CFX	WA32-60.3X3.9SX	66	49	90	1.85
2	60.3X5.5	R-332WA-60.3X5.5S	R32X	BS32SNX	R-332-CFX	WA32-60.3X5.5SX	66	49	90	1.94
2	60.3X8.7	R-332WA-60.3X8.7S	R32X	BS32SNX	R-332-CFX	WA32-60.3X8.7SX	66	43	90	2.24
2	60.3X11.1	R-332WA-60.3X11.1S	R32X	BS32SNX	R-332-CFX	WA32-60.3X11.1SX	66	38	90	2.44
2	66X8.5	R-332WA-66X8.5S	R32X	BS32SNX	R-332-CFX	WA32-66X8.5SX	66	49	75	1.85
2 1/2	65X8.5	R-340WA-65X8.5S	R40X	BS40SNX	R-340-CFX	WA40-65X8.5SX	80	49	105	3.80
2 1/2	73X7.0	R-340WA-73X7.0S	R40X	BS40SNX	R-340-CFX	WA40-73X7.0SX	80	59	105	3.29
2 1/2	75X3.0	R-340WA-75X3.0S	R40X	BS40SNX	R-340-CFX	WA40-75X3.0SX	80	60	105	2.90
2 1/2	75X5.0	R-340WA-75X5.0S	R40X	BS40SNX	R-340-CFX	WA40-75X5.0SX	80	60	105	3.07
2 1/2	76.1X6.3	R-340WA-76.1X6.3S	R40X	BS40SNX	R-340-CFX	WA40-76.1X6.3SX	80	60	105	3.15
2 1/2	76.1X12.5	R-340WA-76.1X12.5S	R40X	BS40SNX	R-340-CFX	WA40-76.1X12.5SX	80	51	105	3.87
2 1/2	80X10.0	R-340WA-80X10.0S	R40X	BS40SNX	R-340-CFX	WA40-80X10.0SX	80	60	90	3.10
3	76.1X12.5	R-348WA-76.1X12.5S	R48X	BS48SNX	R-348-CFX	WA48-76.1X12.5SX	97	51	120	5.68
3	80X10.0	R-348WA-80X10.0S	R48X	BS48SNX	R-348-CFX	WA48-80X10.0SX	97	60	120	5.57
3	88.9X3.1	R-348WA-88.9X3.1S	R48X	BS48SNX	R-348-CFX	WA48-88.9X3.1SX	97	73	120	4.68
3	88.9X5.5	R-348WA-88.9X5.5S	R48X	BS48SNX	R-348-CFX	WA48-88.9X5.5SX	97	73	120	4.97
3	88.9X7.7	R-348WA-88.9X7.7S	R48X	BS48SNX	R-348-CFX	WA48-88.9X7.7SX	97	74	120	5.17
3	88.9X8.8	R-348WA-88.9X8.8S	R48X	BS48SNX	R-348-CFX	WA48-88.9X8.8SX	97	71	120	5.40
3	88.9X11.1	R-348WA-88.9X11.1S	R48X	BS48SNX	R-348-CFX	WA48-88.9X11.1SX	97	67	120	5.84
3	88.9X12.5	R-348WA-88.9X12.5S	R48X	BS48SNX	R-348-CFX	WA48-88.9X12.5SX	97	64	120	6.10
3	88.9X15.2	R-348WA-88.9X15.2S	R48X	BS48SNX	R-348-CFX	WA48-88.9X15.2SX	97	59	120	6.50
3	90X3.5	R-348WA-90X3.5S	R48X	BS48SNX	R-348-CFX	WA48-90X3.5SX	97	73	120	4.69
3	90X5.0	R-348WA-90X5.0S	R48X	BS48SNX	R-348-CFX	WA48-90X5.0SX	97	80	120	5.00
3	90X9.0	R-348WA-90X9.0S	R48X	BS48SNX	R-348-CFX	WA48-90X9.0SX	97	72	120	5.35
3	97X12.0	R-348WA-97X12.0S	R48X	BS48SNX	R-348-CFX	WA48-97X12.0SX	97	73	110	5.15

Other sizes on request.

Please change suffixes according to material/surface required

Order code suffixes		
Material	Suffix surface and material	Example
Steel	S	R-320WA-42X3.0S
Stainless steel	SS	R-320WA-42X3.SS



BF – Bulkhead flange

SAE 3000/ISO 6162-1

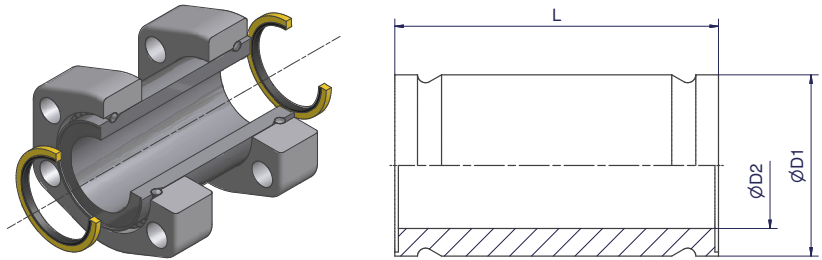

Size Inch	Complete Part Order code	Bulkhead Body Order code	D1	D2	L	Weight body (Steel) kg/1 piece
1/2	R-308BFS	BF08SX	26	14	170	0.49
3/4	R-312BFS	BF12SX	36	20	170	0.92
1	R-316BFS	BF16SX	39	24	170	0.96
1 1/4	R-320BFS	BF20SX	46	30	180	1.30
1 1/2	R-324BFS	BF24SX	56	39	180	1.75
2	R-332BFS	BF32SX	66	49	210	2.45
2 1/2	R-340BFS	BF40SX	80	60	220	3.70
3	R-348BFS	BF48SX	97	73	240	7.85

Please change suffixes according to material/surface required

Order code suffixes		
Material	Suffix surface and material	Example
Steel	S	R-320BFS
Stainless steel	SS	R-320BFSS

RF – Reducer flange

SAE 3000/ISO 6162-1

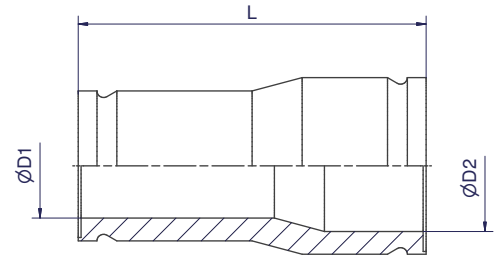
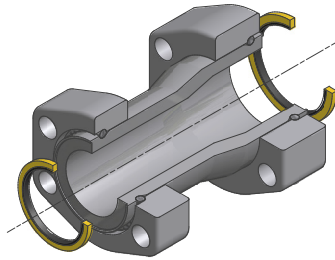

Size Inch	Complete Part Order code	Reducer Body Order code	D1	D2	L	Weight body (Steel) kg/1 piece
3/4 - 1/2	R-312-308RFCF	RF12-08CFX	14	20	65	0.3
1 - 1/2	R-316-308RFCF	RF16-08CFX	14	24	100	0.4
1 - 3/4	R-316-312RFCF	RF16-12CFX	20	24	100	0.6
1 1/4 - 1	R-320-316RFCF	RF20-16CFX	24	30	110	0.7
1 1/2 - 1	R-324-316RFCF	RF24-16CFX	24	39	115	0.9
1 1/2 - 1 1/4	R-324-320RFCF	RF24-20CFX	30	39	130	1.1
2 - 1 1/4	R-332-320RFCF	RF32-20CFX	30	49	130	1.3
2 - 1 1/2	R-332-324RFCF	RF32-24CFX	39	49	130	1.4
2 1/2 - 1 1/2	R-340-324RFCF	RF40-24CFX	39	60	150	2.1
2 1/2 - 2	R-340-332RFCF	RF40-32CFX	49	60	150	2.2
3 - 2	R-348-332RFCF	RF48-32CFX	49	73	180	3.4
3 - 2 1/2	R-348-340RFCF	RF48-40CFX	60	73	180	3.7

Other sizes on request.

Please change suffixes according to material/surface required

Order code suffixes		
Material	Suffix surface and material	Example
Steel, zinc plated, Cr(VI)-free	CF	R-320-316RFCF
Stainless steel	SS	R-320-316RFSS



FB90 – 90° Flange bend

SAE 3000/ISO 6162-1

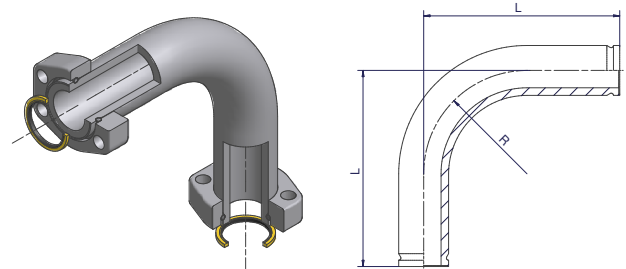

Size Inch	Tube	Complete Part Order code	90° Flange Bend Order code	L	R	Weight body (Steel) kg/1 piece
1 1/4	46X8.0	R-320FB90S	FB90-20SX*	180	96	2.35
1 1/2	56X8.5	R-324FB90CF	FB90-24CFX	220	116	3.84
2	66X8.5	R-332FB90CF	FB90-32CFX	275	165	5.72
2 1/2	80X10.0	R-340FB90S*	FB90-40SX*	370	200	11.20
3	97X12.0	R-348FB90S*	FB90-48SX*	450	243	19.90

Other sizes on request.
*only available as steel version

Please change suffixes according to material/surface required

Order code suffixes			
Tube material	Suffix surface and material	Example	Comments
Steel, zinc plated, Cr(VI)-free	CFX	R-324FB90CF	
Steel, black phosphated	SX	R-320FB90S	
Stainless steel	SS	R-320FB90SS	on request

FB45 – 45° Flange bend

SAE 3000/ISO 6162-1

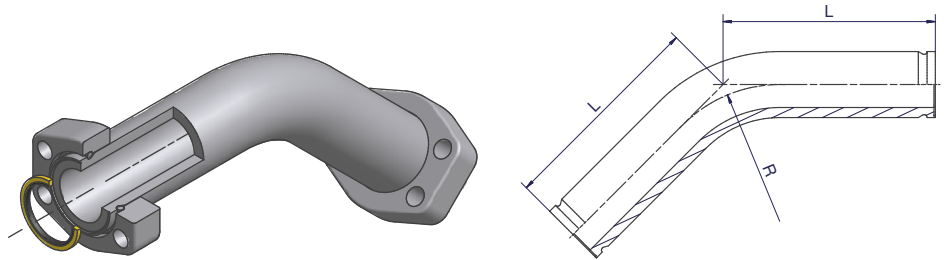

Size Inch	Tube	Complete Part Order code	45° Flange Bend Order code	L	R	Weight body (Steel) kg/1 piece
1 1/4	46X8.0	R-320FB45S	FB45-20SX	150	96	2.18
1 1/2	56X8.5	R-324FB45CF	FB45-24CFX	180	116	3.49
2	66X8.5	R-332FB45CF	FB45-32CFX	220	165	5.16
2 1/2	80X10.0	R-340FB45S*	FB45-40SX*	240	200	8.07
3	97X12.0	R-348FB45S*	FB45-48SX*	260	243	12.70

Other sizes on request.
*only available as steel version

Please change suffixes according to material/surface required

Order code suffixes			
Tube material	Suffix surface and material	Example	Comments
Steel, zinc plated, Cr(VI)-free	CFX	R-324FB45CF	
Steel, black phosphated	SX	R-320FB45S	
Stainless steel	SS	R-320FB45SS	on request



FB90 – 90° Flange bend

SAE 3000/ISO 6162-1

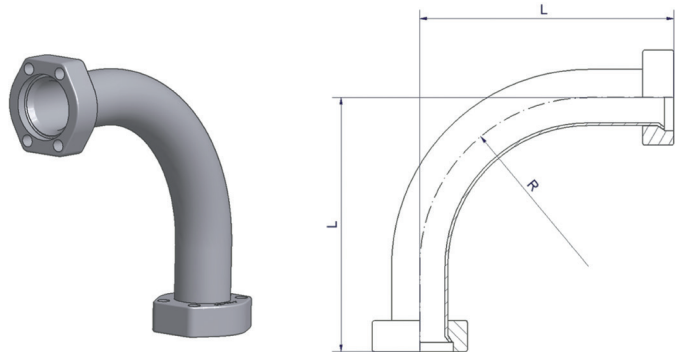

Size Inch	Tube	Complete Part Order code	L	R
1 1/2	50X5.0	F37-324FB90	220	150.0
2	60X5.0	F37-332FB90	275	180.0
2 1/2	75X5.0	F37-340FB90	370	187.5
3	90X3.5	F37-348FB90*	450	225.0
3	90x5.0	F37-348905FB90*	450	225.0

Other sizes on request.
 *only available as Steel version, example: F37-348FB90S

Please change suffixes according to material/surface required

Order code suffixes		
Material	Suffix surface and material	Example
Steel, zinc plated, Cr(VI)-free	CF	F37-324FB90CF
Steel	S	F37-348FB90S
Stainless steel	SS	F37-324FB90SS

FB45 – 45° Flange bend

SAE 3000/ISO 6162-1

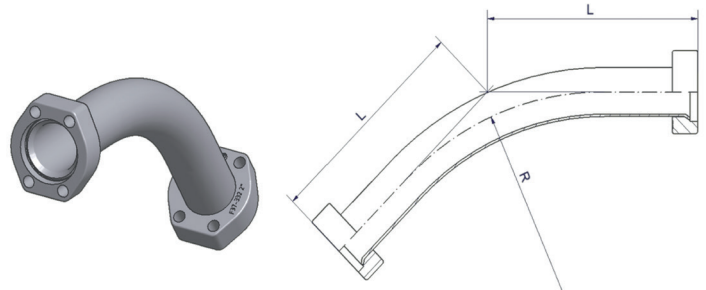

Size Inch	Tube	Complete Part Order code	L	R
1 1/2	50X5.0	F37-324FB45	220	150.0
2	60X5.0	F37-332FB45	275	180.0
2 1/2	75X5.0	F37-340FB45	370	187.5
3	90X5.0	F37-348905FB45*	370	187.5

Other sizes on request.
 *only available as Steel Version, example: F37-348905FB45S

Please change suffixes according to material/surface required

Order code suffixes		
Material	Suffix surface and material	Example
Steel, zinc plated, Cr(VI)-free	CF	F37-324FB45CF
Steel	S	F37-348905FB45S
Stainless steel	SS	F37-324FB45SS



LF – Elbow flange

SAE 3000/ISO 6162-1

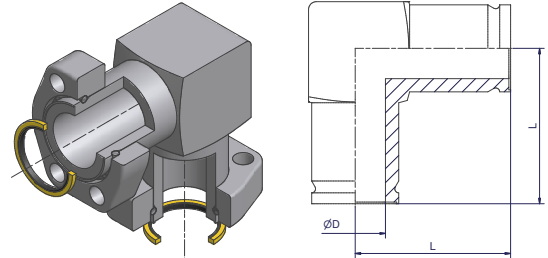

Size Inch	Complete Part Order code	Elbow Flange body Order code	D	L	Weight body (Steel) kg/1 piece
1/2	R-308LFCF	LF08CFX	14	70	0.50
3/4	R-312LFCF	LF12CFX	20	80	1.07
1	R-316LFCF	LF16CFX	24	85	1.32
1 1/4	R-320LFCF	LF20CFX	30	90	1.72
1 1/2	R-324LFCF	LF24CFX	39	100	2.60
2	R-332LFCF	LF32CFX	49	110	4.00
2 1/2	R-340LFCF	LF40CFX	60	130	6.40
3	R-348LFCF	LF48CFX	73	160	10.80

Other sizes on request.

Please change suffixes according to material/surface required

Order code suffixes		
Material	Suffix surface and material	Example
Steel, zinc plated, Cr(VI)-free	CF	R-320LFCF
Stainless steel	SS	R-320LFSS

TF – TEE flange

SAE 3000/ISO 6162-1

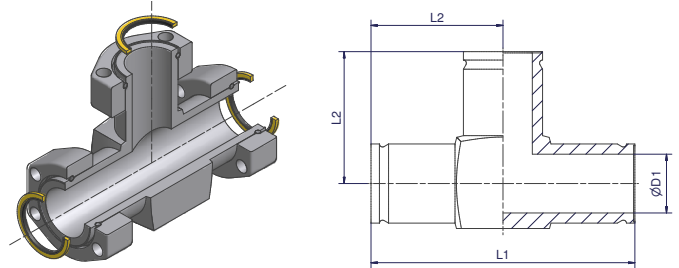

Size Inch	Complete Part Order code	Tee Flange body Order code	D1	L1	L2	Weight body (Steel) kg/1 piece
1/2	R-308TFCF	TF08CFX	14	120	60	0.75
3/4	R-312TFCF	TF12CFX	20	130	65	1.60
1	R-316TFCF	TF16CFX	24	140	70	2.00
1 1/4	R-320TFCF	TF20CFX	30	180	90	2.03
1 1/2	R-324TFCF	TF24CFX	39	200	100	3.13
2	R-332TFCF	TF32CFX	49	220	110	4.53
2 1/2	R-340TFCF	TF40CFX	60	260	130	7.05
3	R-348TFCF	TF48CFX	73	320	160	12.81

Other sizes on request.

Please change suffixes according to material/surface required

Order code suffixes		
Material	Suffix surface and material	Example
Steel, zinc plated, Cr(VI)-free	CF	R-320TFCF
Stainless steel	SS	R-320TFSS



LB – Flange L-block

SAE 3000/ISO 6162-1

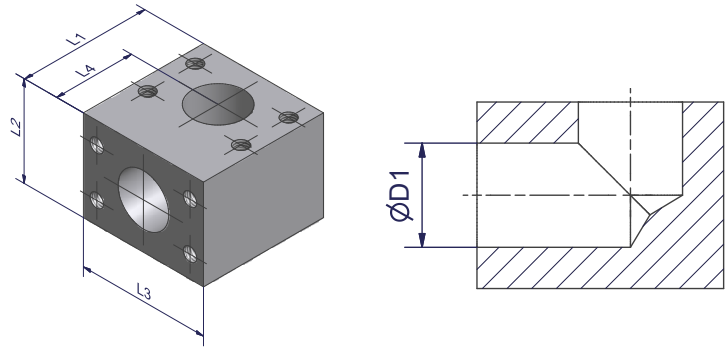

Size Inch	Order code	D1	L1	L2	L3	L4	Weight (Steel) kg/1 piece
1	LB316CFX	25	70	48	70	46	1.5
1 1/4	LB320CFX	30	80	58	80	51	2.4
1 1/2	LB324CFX	38	90	68	90	56	3.4
2	LB332CFX	48	96	78	100	57	4.4
2 1/2	LB340CFX	60	110	88	110	65	6.0
3	LB348CFX	73	135	110	135	80	11.3

Other sizes and custom versions on request.

Please change suffixes according to material/surface required

Order code suffixes		
Material	Suffix surface and material	Example
Steel, zinc plated, Cr(VI)-free	CF	LB320CFX
Stainless steel	SS	LB320SSX

LBR – Flange L-block reducer

SAE 3000/ISO 6162-1

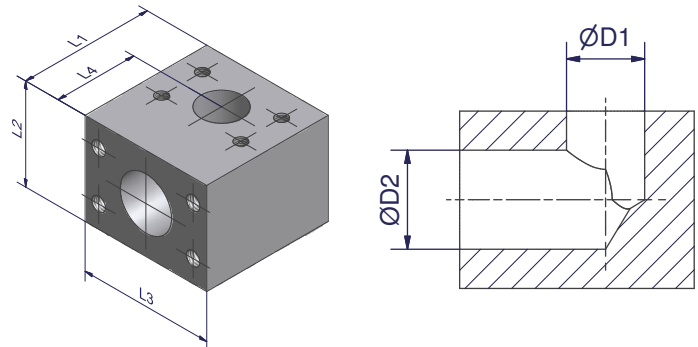

Size Inch	Order code	D1	D2	L1	L2	L3	L4	Weight (Steel) kg/1 piece
1 1/4 - 1	LBR320-316CFX	25	30	80	58	80	51	2.4
1 1/2 - 1	LBR324-316CFX	25	38	90	68	90	56	3.6
1 1/2 - 1 1/4	LBR324-320CFX	30	38	90	68	90	56	3.6
2 - 1	LBR332-316CFX	25	48	96	78	100	57	4.7
2 - 1 1/4	LBR332-320CFX	30	48	96	78	100	57	4.7
2 - 1 1/2	LBR332-324CFX	38	48	96	78	100	57	4.6
2 1/2 - 1 1/2	LBR340-324CFX	38	60	110	88	110	65	6.4
2 1/2 - 2	LBR340-332CFX	48	60	110	88	110	65	6.2
3 - 2	LBR348-332CFX	48	73	135	110	135	80	12.2
3 - 2 1/2	LBR348-340CFX	60	73	135	110	135	80	11.8

Other sizes and custom versions on request.

Please change suffixes according to material/surface required

Order code suffixes		
Material	Suffix surface and material	Example
Steel, zinc plated, Cr(VI)-free	CF	LBR320-316CFX
Stainless steel	SS	LBR320-316SSX



TB – Flange T-block

SAE 3000/ISO 6162-1

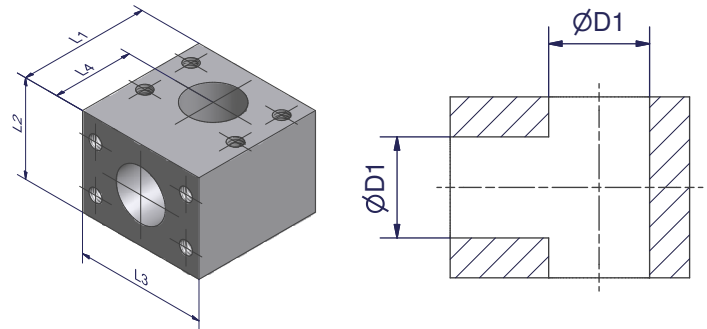

Size Inch	Order code	D1	L1	L2	L3	L4	Weight (Steel) kg/1 piece
1/2	TB308CFX	13	60	50	60	37	1.2
3/4	TB312CFX	19	68	55	66	44	1.6
1	TB316CFX	25	70	55	70	46	1.6
1 1/4	TB320CFX	30	80	58	80	51	2.2
1 1/2	TB324CFX	38	90	68	90	56	3.1
2	TB332CFX	48	96	78	100	57	3.9
2 1/2	TB340CFX	60	110	88	110	65	5.3
3	TB348CFX	73	135	110	135	80	10.0

Other sizes and custom versions on request.

Please change suffixes according to material/surface required

Order code suffixes		
Material	Suffix surface and material	Example
Steel, zinc plated, Cr(VI)-free	CF	TB320CFX
Stainless steel	SS	TB320SSX

TBR – Flange T-block reducer

SAE 3000/ISO 6162-1

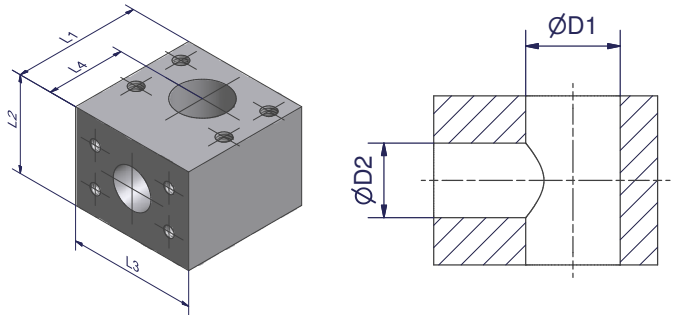

Size Inch	Order code	D1	D2	L1	L2	L3	L4	Weight (Steel) kg/1 piece
1 1/4 - 3/4 - 1 1/4	TBR320-312-320CFX	30	19	80	55	80	51	2.2
1 1/4 - 1 - 1 1/4	TBR320-316-320CFX	30	25	80	58	80	51	2.3
1 1/2 - 1 1/4 - 1 1/2	TBR324-320-324CFX	38	30	90	68	90	56	3.3
1 1/2 - 1 - 1 1/2	TBR324-316-324CFX	38	25	90	68	90	56	3.4
2 - 1 1/2 - 2	TBR332-324-332CFX	48	38	96	78	100	57	4.2
2 - 1 1/4 - 2	TBR332-320-332CFX	48	30	96	78	100	57	4.3
2 1/2 - 2 - 2 1/2	TBR340-332-340CFX	60	48	110	88	110	65	5.6
2 1/2 - 1 1/2 - 2 1/2	TBR340-324-340CFX	60	38	110	88	110	65	5.9
3 - 2 1/2 - 3	TBR348-340-348CFX	73	60	135	110	135	80	10.6
3 - 2 - 3	TBR348-332-348CFX	73	48	135	110	135	80	11.0

Other sizes and custom versions on request.

Please change suffixes according to material/surface required

Order code suffixes		
Material	Suffix surface and material	Example
Steel, zinc plated, Cr(VI)-free	CF	TBR320-316-320CFX
Stainless steel	SS	TBR320-316-320SSX



BFV – Blind flange

SAE 3000/ISO 6162-1

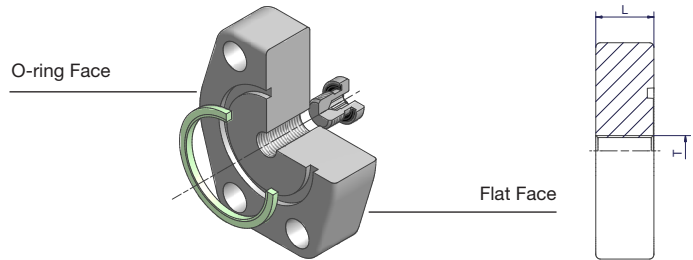

Size Inch	Flange incl. VSTI-ED and F37 Seal Order code	L	T	Weight body (Steel) kg/1 piece
1/2	F37-308BFVCF	19	G 1/4	0.24
3/4	F37-312BFVCF	20	G 1/4	0.37
1	F37-316BFVCF	24	G 1/4	0.60
1 1/4	F37-320BFVCF	22	G 1/4	0.70
1 1/2	F37-324BFVCF	25	G 1/4	1.10
2	F37-332BFVCF	33	G 1/4	2.00
2 1/2	F37-340BFVCF	44	G 1/4	3.45
3	F37-348BFVCF	50	G 1/4	5.45

Please change suffixes according to material/surface required

Order code suffixes		
Material	Suffix surface and material	Example
Steel, zinc plated, Cr(VI)-free	CF	F37-320BFVCF
Stainless steel	SS	F37-320BFVSS

BS – Bonded seal

SAE 3000/ISO 6162-1

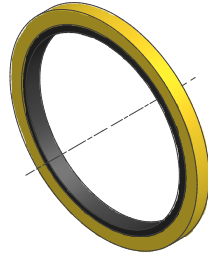

Size Inch	Steel	Stainless Steel
1/2	BS08SNX	BS08SSNX
3/4	BS12SNX	BS12SSNX
1	BS16SNX	BS16SSNX
1 1/4	BS20SNX	BS20SSNX
1 1/2	BS24SNX	BS24SSNX
2	BS32SNX	BS32SSNX
2 1/2	BS40SNX	BS40SSNX
3	BS48SNX	BS48SSNX

Sealing: NBR
Other sealing materials like FKM on request.

F37S/F37RS – F37 seal

SAE 3000/ISO 6162-1

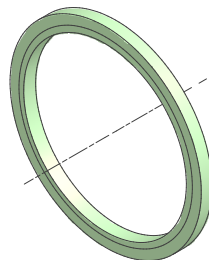

Size Inch	F37 Seal (F37 seal for flaring system)	F37 RS (F37 seal for retaining ring system)
1/2	F37S08X	-
3/4	F37S12X	-
1	F37S16X	-
1 1/4	F37S20X	F37RS20X
1 1/2	F37S24X	F37RS24X
2	F37S32X	F37RS32X
2 1/2	F37S40X	F37RS40X
3	F37S48X	F37RS48X

Sealing: Polyurethane
Material properties and applications see page 22.
Other sizes on request.



AO – Adapter bonded seal to F37 seal/O-Ring

SAE 3000/ISO 6162-1

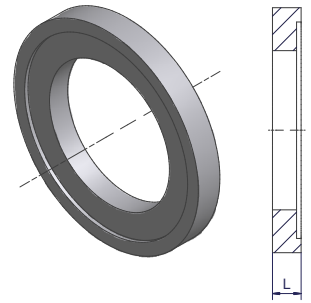

Size Inch	Adapter Order code	L	Weight (Steel) kg/1 piece
1/2	AO08CFX	5	0.01
3/4	AO12CFX	5	0.02
1	AO16CFX	7	0.06
1 1/4	AO20CFX	7	0.06
1 1/2	AO24CFX	7	0.08
2	AO32CFX	7	0.10
2 1/2	AO40CFX	7	0.14
3	AO48CFX	7	0.20

Please change suffixes according to material/surface required

Order code suffixes		
Material	Suffix surface and material	Example
Steel, zinc plated, Cr(VI)-free	CF	AO32CFX
Stainless steel	SS	AO32SSX

TBT – TEE between bonded seal

SAE 3000/ISO 6162-1

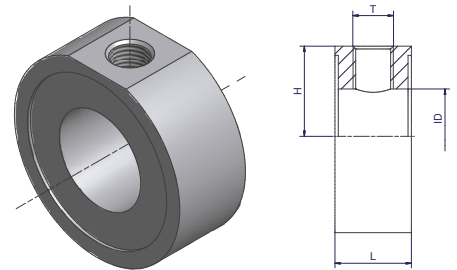

Size Inch	Order code*	L	H	T	ID	Weight body (Steel) kg/1 piece
1	TBT16-1/4CFX	25	20.5	G 1/4 A	25	0.21
1 1/4	TBT20-1/4CFX	25	24.5	G 1/4 A	27	0.30
1 1/4	TBT20-1/2CFX	40	22.5	G 1/2 A	24	0.49
1 1/2	TBT24-1/4CFX	25	29.5	G 1/4 A	31	0.42
1 1/2	TBT24-1/2CFX	40	28.0	G 1/2 A	30	0.68
2	TBT32-1/4CFX	25	35.0	G 1/4 A	41	0.51
2	TBT32-1/2CFX	40	34.0	G 1/2 A	38	0.87
2 1/2	TBT40-1/4CFX	30	41.5	G 1/4 A	60	0.63
3	TBT48-1/4CFX	30	50.0	G 1/4 A	72	0.90

*For testpoints and diagnostic test equipment see catalogue 4100, Industrial Tube Fittings Europe.
For assembling add L to the corresponding bolt length.

Alternative versions on request.

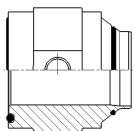

TFVB

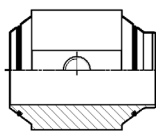

TTb

Please change suffixes according to material/surface required

Order code suffixes		
Material	Suffix surface and material	Example
Steel, zinc plated, Cr(VI)-free	CF	TBT24-1/4CFX
Stainless steel	SS	TBT24-1/4SSX



AP – SAE flange locking plate

SAE 3000/ISO 6162-1

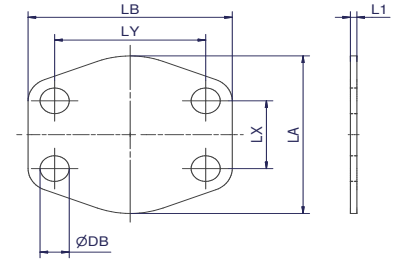

Nom. flange size		Order code	L1	LA	LB	LX	LY	DB	Weight body (Steel) kg/1 piece
SAE (In)	ISO (DN)								
1/2	13	8AP1	3	46	54	17.5	38.1	9.0	0.01
3/4	19	12AP1	3	52	65	22.3	47.6	11.0	0.01
1	25	16AP1	3	59	70	26.2	52.4	11.0	0.01
1 1/4	32	20AP1	3	73	79	30.2	58.7	11.5	0.01
1 1/2	38	24AP1	3	83	94	35.7	69.9	13.5	0.02
2	51	32AP1	3	97	102	42.9	77.8	13.5	0.02
2 1/2	64	40AP1	3	109	114	50.8	88.9	13.5	0.03
3	76	48AP1	4	131	135	61.9	106.4	17.0	0.06

This flange locking plate to be not used under pressure!

Please change suffixes according to material/surface required

Order code suffixes			
Material	Suffix surface and material	Example	Description
Steel, zinc plated, Cr(VI)-free	CF	8AP1CF	only locking plate
Stainless steel	SS	8AP1SS	only locking plate
Steel (zinc plated, Cr(VI)-free), SBR 70 Shore A	CFSBR70	8AP1CFSBR70	locking incl. rubber plate L1 increases due to rubber plate

Bolts and nuts for flange

SAE 3000/ISO 6162-1



F37 Flare Flange

Size Inch	Flange	F37 Seal / Flat Face / Bonded Seal		Nut
		Recommended bolts Tube to Port	Recommended bolts Tube to Tube	
1/2	F37-308-CFX	4x ZYLS8X35	4x ZYLS8X55	4x ISO4032-M8
3/4	F37-312-CFX	4x ZYLS10X40	4x ZYLS10X65	4x ISO4032-M10
1	F37-316-CFX	4x ZYLS10X45	4x ZYLS10X75	4x ISO4032-M10
1 1/4	F37-320-CFX	4x ZYLS10X40	4x ZYLS10X70	4x ISO4032-M10
1 1/2	F37-324-CFX	4x ZYLS12X45	4x ZYLS12X80	4x ISO4032-M12
2	F37-332-CFX	4x ZYLS12X55	4x ZYLS12X100	4x ISO4032-M12
2 1/2	F37-340-CFX	4x ZYLS12X65	4x ZYLS12X120	4x ISO4032-M12
3	F37-348-CFX	4x ZYLS16X80	4x ZYLS16X140	4x ISO4032-M16

Retaining Ring Flange

Size Inch	Flange	F37 Seal / Flat Face / Bonded Seal		Pipe Seal Carrier (PSC)		Nut
		Recommended bolts Tube to Port	Recommended bolts Tube to Tube	Recommended bolts Tube to Port	Recommended bolts Tube to Tube	
1/2	R-308-CFX	4x ZYLS8X35	4x ZYLS8X60	-	-	4x ISO4032-M8
3/4	R-312-CFX	4x ZYLS10X40	4x ZYLS10X65	-	-	4x ISO4032-M10
1	R-316-CFX	4x ZYLS10X40	4x ZYLS10X70	-	-	4x ISO4032-M10
1 1/4	R-320-CFX	4x ZYLS10X40	4x ZYLS10X70	4x ZYLS10X50	4x ZYLS10X80	4x ISO4032-M10
1 1/2	R-324-CFX	4x ZYLS12X50	4x ZYLS12X80	4x ZYLS12X55	4x ZYLS12X90	4x ISO4032-M12
2	R-332-CFX	4x ZYLS12X55	4x ZYLS12X90	4x ZYLS12X65	4x ZYLS12X100	4x ISO4032-M12
2 1/2	R-340-CFX	4x ZYLS12X65	4x ZYLS12X120	4x ZYLS12X80	4x ZYLS12X130	4x ISO4032-M12
3	R-348-CFX	4x ZYLS16X80	4x ZYLS16X130	4x ZYLS16X90	4x ZYLS16X150	4x ISO4032-M16

Bolts and nuts are not included in complete part numbers.

Latest information about nuts and bolts see www.parker.com/hpcc -> Resources -> Installation Guides & Manuals

Please add the suffixes according to the bolt quality

	Steel		Stainless Steel
Grade	8.8 zinc plated (VZX)	10.9 zinc flaked (ZNFLX)	A4-80X
Bolt	ZYLS16X60VZX	ZYLS16X60109ZNFLX	ZYLS16X60A4-80X
Nut	ISO4032-M12-8VZX	ISO4032-M12-10ZNFLX	ISO4032-M12-80X



KH – Ball valve drilled and tapped for SAE 3000 and SAE 6000 Flanges

SAE 3000/ISO 6162-1

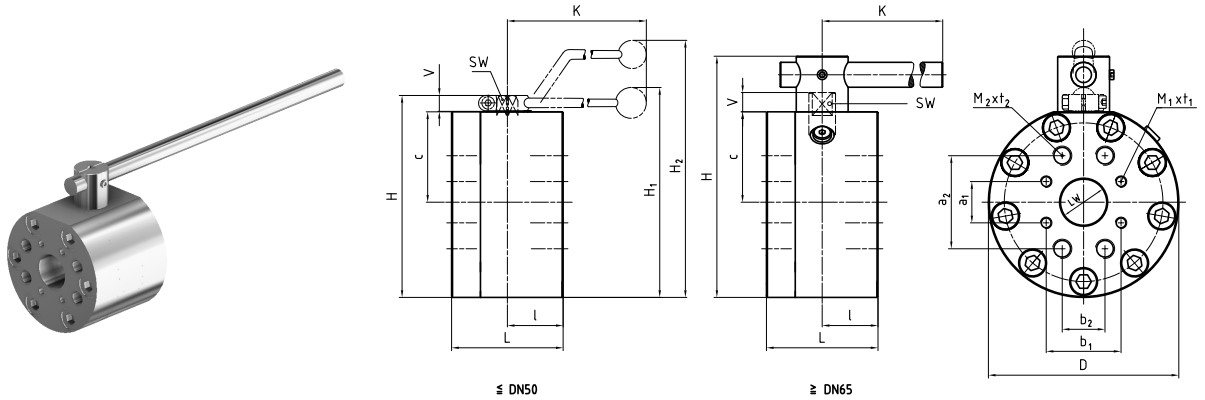

Material Steel

Size Inch	Order Code	DN	LW	L	I	D	H	c	V	K	SW	SAE 3000 boring pattern				SAE 6000 boring pattern				H1	H2	Material Code	Lever	Weight kg	W.P. (bar)
												a1	b1	M1	t1	a2	b2	M2	t2						
1/2	KH08-15CF	15	15	75	35	88	88	31.0	13	170	12	17.5	38.1	M08	18	40.5	18.2	M08	18	-	132	212A	St	2.96	350 / 420
3/4	KH12-20CF	20	20	80	35	98	100	36.5	14	170	14	22.2	47.6	M10	18	50.8	23.8	M10	18	-	150	212A	St	4.20	350 / 420
1	KH16-25CF	25	25	88	38	118	113	39.5	14	170	14	26.2	52.4	M10	20	57.2	27.8	M10	20	-	163	212A	St	6.00	320 / 420
1 1/4	KH20-32CF*	32	32	100	50	145	158	68.0	17	306	17	30.2	58.7	M10	20	66.7	31.8	M12	22	-	232	212A	St	11.70	280 / 420
1 1/4	KH20-32TM1214CF*	32	32	100	50	145	158	68.0	17	306	17	30.2	58.7	M12	20	66.7	31.8	M14	22	-	232	212A	St	11.65	210 / 400
1 1/2	KH24-38CF	40	38	110	55	165	178	78.0	17	306	17	35.7	69.9	M12	20	79.4	36.5	M16	27	-	252	212A	St	17.10	210 / 420
2	KH32-48CF	50	48	116	58	198	210	94.0	17	306	17	42.9	77.8	M12	20	96.8	44.5	M20	28	-	284	212A	St	24.60	210 / 420
2 1/2	KH40-63CF	65	63	170	75	218	275	100.0	20	600	16	88.9	50.8	M12	19	58.7	123.8	M24	41	-	-	282A	St	44.40	175 / 420
3	KH48-76CF	80	76	170	79	258	315	115.0	26	600	19	106.4	61.9	M16	24	71.4	152.4	M30	47	-	-	282A	St	54.90	160 / 420

*Please choose between KH20-32CF and KH20-32TM1214CF according to needed connection threads M1 and M2.
Steel ball valves 1/2" up to 3" with SAE 3000 and SAE 6000 boring pattern.
The bore pattern for 2 1/2" and 3" is turned to 90°.

Please change suffixes according to material/surface required

Order code suffixes		
Material	Suffix surface and material	Example
Steel, zinc plated, Cr(VI)-free	CF	KH20-32CF

	Material 212A	Material 282A
Body	Steel	Steel
Ball	Steel	Steel
Stem	Steel	Stainless Steel
Ball seats	POM	POM
O-Ring	NBR	NBR
Tmin / T max	-10°C / 100°C	-10°C / 100°C

KH – Ball valve drilled and tapped for SAE 3000 Flanges

SAE 3000/ISO 6162-1

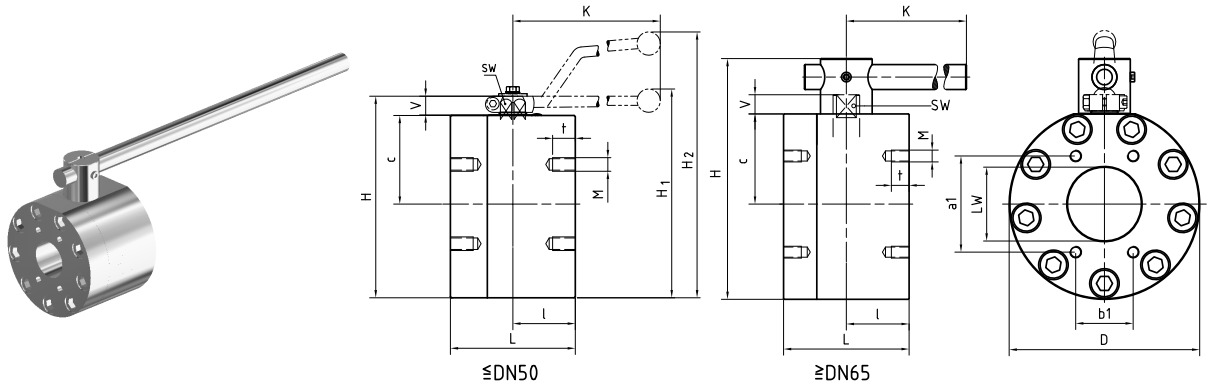

Material Stainless Steel

Size Inch	Order Code	DN	LW	L	I	D	H	c	V	K	SW	a1	b1	M	t	H1	H2	Material Code	Lever	Weight kg	W.P. (bar)
1/2	KH308-15SS	15	15	75	35	78	83	31.0	13	160	12	38.1	17.5	M08	18	-	127	442A	Al	2.96	350
3/4	KH312-20SS	20	20	80	35	98	100	36.5	14	200	14	47.6	22.2	M10	18	103	-	442A	Zn	4.20	350
1	KH316-25SS	25	25	88	38	118	113	39.5	14	200	14	52.4	26.2	M10	20	116	-	442A	Zn	6.00	320
1 1/4	KH320-32SS*	32	32	100	50	145	158	68.0	17	320	17	58.7	30.2	M10	20	167	-	442A	Al	11.70	280
1 1/4	KH320-32TM12SS*	32	32	100	50	145	158	68.0	17	320	17	58.7	30.2	M12	20	167	-	442A	Al	11.65	210
1 1/2	KH324-38SS	40	38	110	55	165	178	78.0	17	320	17	69.9	35.7	M12	20	187	-	442A	Al	17.10	210
2	KH332-48SS	50	48	116	58	198	210	94.0	17	320	17	77.8	42.9	M12	20	219	-	442A	Al	24.60	210
2 1/2	KH340-63SS	65	63	150	75	198	259	94.0	20	600	16	88.9	50.8	M12	19	-	-	442A	St	35.50	175
3	KH348-76SS	80	76	150	79	218	284	104.0	26	600	19	106.4	61.9	M16	24	-	-	442A	St	40.00	160

*Please choose between KH320-32SS and KH320-32TM12SS according to needed connection thread M.
For 4" and 5" Ball valves see chapter Parflange® F37 - SAE 1000/ISO 6162-1 footprint.

Please change suffixes according to material/surface required

Order code suffixes		
Material	Suffix surface and material	Example
Stainless steel	SS	KH320-32SS

	Material 442A
Body	Stainless Steel
Ball	Stainless Steel
Stem	Stainless Steel
Ball seats	POM
O-Ring	NBR
Tmin / T max	-30°C / 100°C



KH-R – Ball valve with SAE 3000 Flanges

SAE 3000/ISO 6162-1

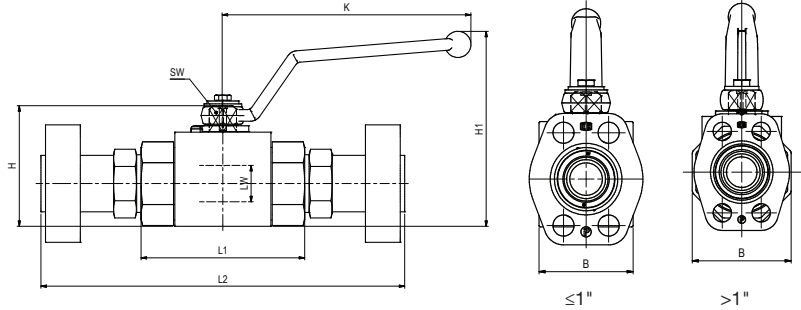
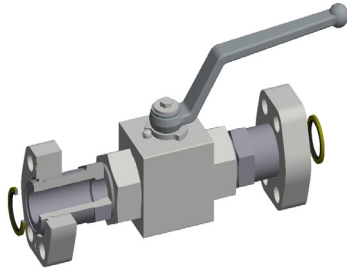

Material Steel

Size Inch	Complete part Order code	Valve body Order code	LW	L1	L2	B	H	SW	K	H1	Weight (Steel) kg/1 kit	W.P. bar
3/4	KH-R-312-20CF	KH-R-12-20CF	20	95	217	49	75	14	171	126	2.5	350
1	KH-R-316-25CF	KH-R-16-25CF	25	113	251	58	83	14	171	134	3.8	350
1 1/4	KH-R-320-32CF	KH-R-20-32CF	32	111	271	81	107	17	306	178	6.0	280
1 1/2	KH-R-324-38CF	KH-R-24-38CF	38	130	316	100	124	17	306	196	8.4	280
2	KH-R-332-48CF	KH-R-32-48CF	48	140	348	118	138	17	306	210	13.9	280

Other sizes on request.

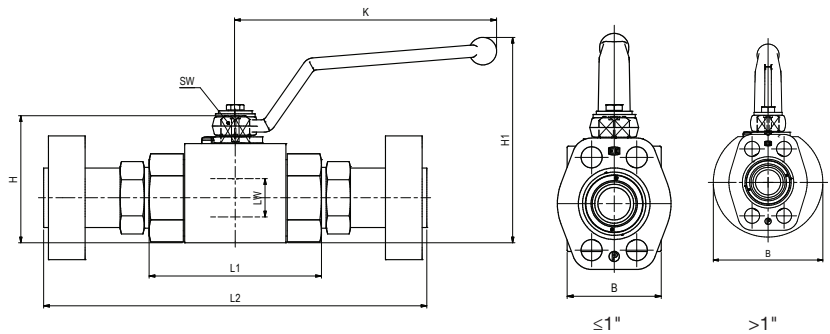
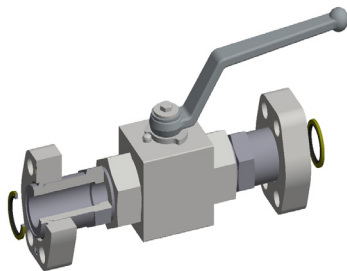

Material Stainless Steel

Size Inch	Complete part Order code	Valve body Order code	LW	L1	L2	B	H	SW	K	H1	Weight (Steel) kg/1 kit	W.P. bar
3/4	KH-R-312-20SS	KH-R-12-20SS	20	95	217	49	75	14	171	126	2.5	350
1	KH-R-316-25SS	KH-R-16-25SS	25	113	251	58	83	14	171	134	3.8	350
1 1/4	KH-R-320-32SS	KH-R-20-32SS	32	111	271	109	121	17	228	195	8.6	280
1 1/2	KH-R-324-38SS	KH-R-24-38SS	38	130	316	124	136	17	228	210	12.0	280
2	KH-R-332-48SS	KH-R-32-48SS	48	140	348	132	145	17	228	219	16.1	280

Other sizes on request.

Please change suffixes according to material/surface required

Order code suffixes			
Material	Suffix surface and material	Example	Comments
Steel, zinc plated, Cr(VI)-free	CF	KH-R-320-32CF	
Stainless steel	SS	KH-R-320-32SS	on request

	Material 112A	Material 442A
Body	Steel	Stainless Steel
Ball	Steel	Stainless Steel
Stem	Steel	Stainless Steel
Ball seats	POM	POM
O-Ring	NBR	NBR
Tmin / T max	-20°C / 100 °C	-30°C / 100°C

RHD-R – Non return valves

SAE 3000/ISO 6162-1

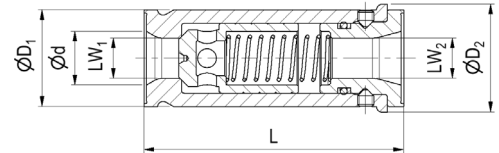
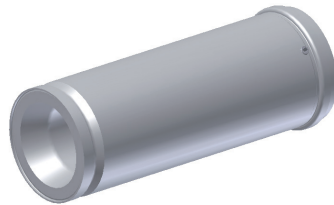

Size Inch	Complete part Order code	Valve body Order code	L	D1	D2	d	LW1	LW2	Weight body (Steel) kg/1 piece	W.P. bar
3/4	RHD-R-312-0.5BCF	RHD-R-12-0.5BCF	96.4	36	40.2	20.0	15	15.0	0.53	210
1	RHD-R-316-0.5BCF	RHD-R-16-0.5BCF	116.6	39	44.2	23.0	18	13.0	0.78	
1 1/4	RHD-R-320-0.5BCF	RHD-R-20-0.5BCF	135.6	46	51.1	30.0	20	17.0	1.26	
1 1/2	RHD-R-324-0.5BCF	RHD-R-24-0.5BCF	135.6	56	60.5	38.8	30	27.0	1.61	
2	RHD-R-332-0.5BCF	RHD-R-32-0.5BCF	180.1	66	70.5	49.0	40	36.4	2.54	
2 1/2	RHD-R-340-0.5BCF	RHD-R-40-0.5BCF	190.0	80	84.5	60.0	50	46.8	3.89	
3	RHD-R-348-0.5BCF	RHD-R-48-0.5BCF	200.0	97	103.2	73.0	63	62.8	5.90	

Opening pressure 0.5 bar. Other pressure rates on request.
Complete Part = body + flanges + retaining rings + bonded seals.

Please change suffixes according to material/surface required

Order code suffixes		
Material	Suffix surface and material	Example
Steel, zinc plated, Cr(VI)-free	CF	RHD-R-320-0.5BCF
Stainless steel (inner parts steel)	SS	RHD-R-320-0.5BSS

	Materials
Body	Steel/Stainless Steel
Piston	Steel
O-Ring	NBR
Tmin / T max	-10°C / 100 °C



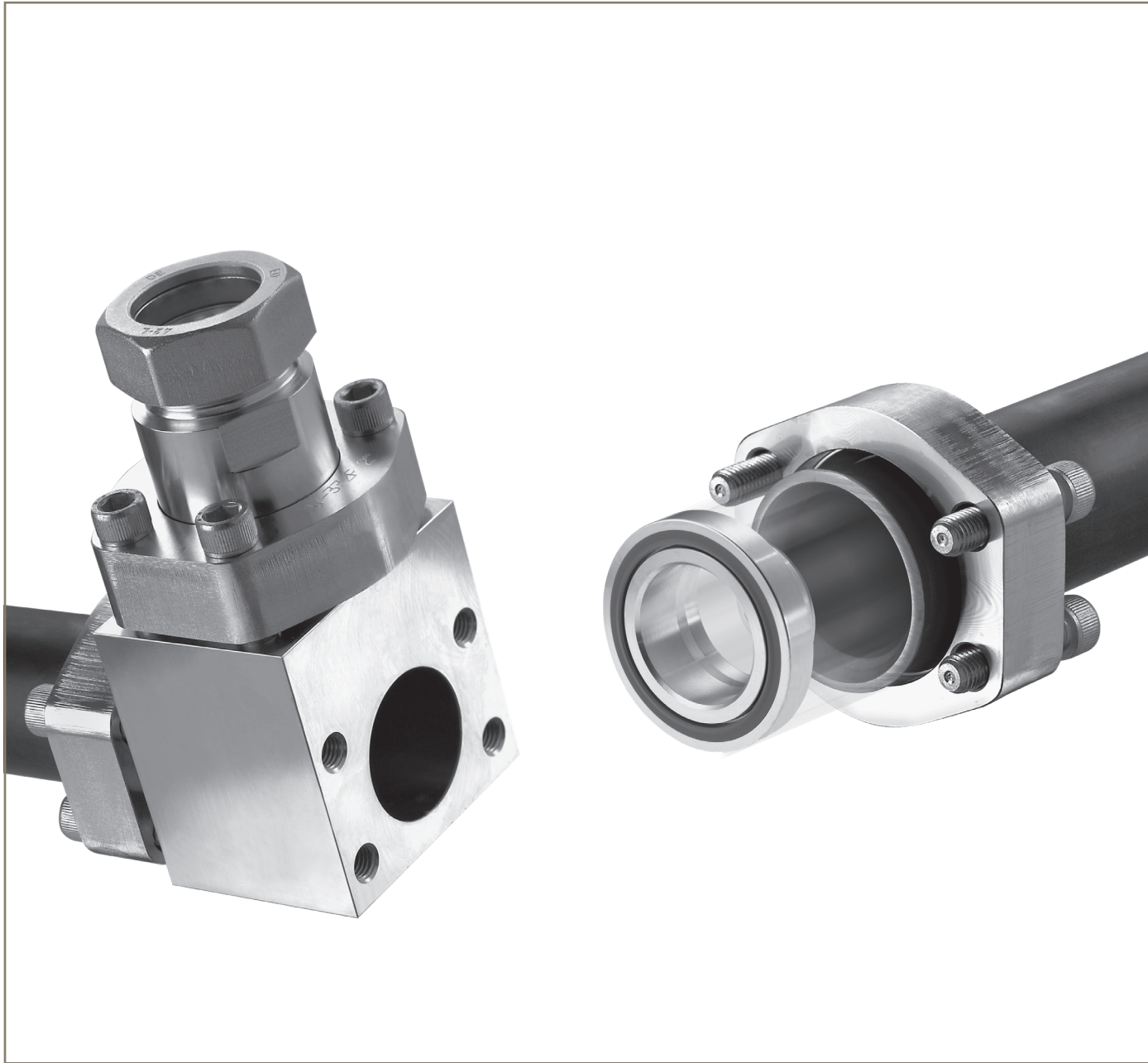









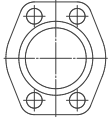



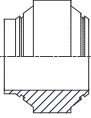
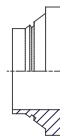
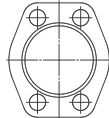

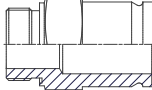
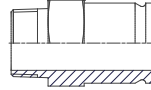

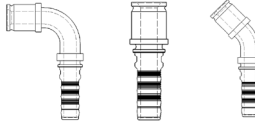
SAE 6000 System

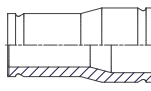
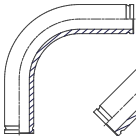
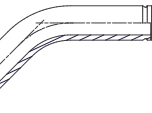
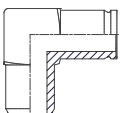
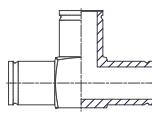
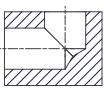
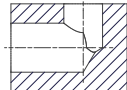
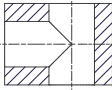
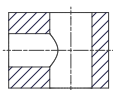
420 bar

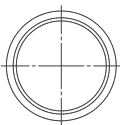
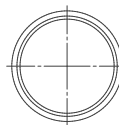
ENGINEERING YOUR SUCCESS.

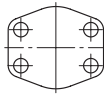
Programme overview SAE 6000/ISO 6162-2 footprint

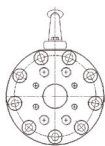
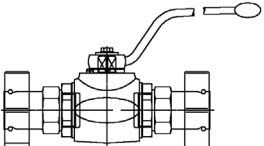
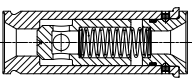
Parflange® F37 connection parts	Flanges  F37 – p.101/102					Sleeve  SL – p.109	
	Inserts     TFB – p.105 TFV – p.106 TT – p.107 TF – p.108						
Retaining ring connection parts	Flanges    R – p.103 R-Ring – p.108 PSC – p.104			Male / Female    MTF-R – p.111 MTF-N – p.112 FTF-R – p.113		Hose  Hose – p.114	Weld  WA – p.115/116
	Tube to Tube       BF – p.117 RF – p.118 FB90 – p.119/121 FB45 – p.120/122 LF – p.123 TF – p.124						
	SAE connection parts Blocks      LB – p.125 LBR – p.126 TB – p.127 TBR – p.128 BFV – p.129						
Seals Adapter Bolts	Components      BS – p.130 F37S – p.130 AO – p.131 TBT – p.132 AP – p.133					Bolts and Nuts  p.134	
	Ball valves    KH – p.135/136 KH-R – p.137 RHD-R – p.138						



F37 – Flare flange | SAE 6000/ISO 6162-2 footprint

SAE 6000/ISO 6162-2

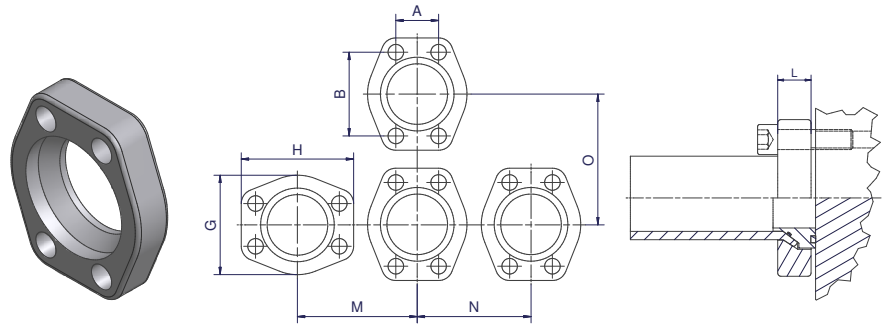

Parflange F37 flange dimensions

* Jump size flanges (no adapter sleeves (SL...) necessary).

Size Inch	Flange Order code	A	B	G	H	M	N	O	L	Weight body (Steel) kg/1 piece	W.P. bar
1/2	F37-608-CFX	18.2	40.5	48	56	57	53	61	20	0.20	420
3/4	F37-612-CFX	23.8	50.8	60	71	70	65	76	24	0.35	420
3/4	F37-612/25-CFX*	23.8	50.8	60	71	70	65	76	24	0.45	420
1	F37-616-CFX	27.8	57.2	70	81	80	75	86	24	0.53	420
1	F37-616/25-CFX*	27.8	57.2	70	81	80	75	86	24	0.64	420
1	F37-616/30-CFX*	27.8	57.2	70	81	80	75	86	24	0.59	420
1 1/4	F37-620-CFX	31.8	66.6	78	95	91	83	100	30	0.92	420
1 1/4	F37-620H12-CFX**	31.8	66.6	78	95	91	83	100	30	0.96	420
1 1/4	F37-620/38-CFX*	31.8	66.6	78	95	91	83	100	30	0.96	420
1 1/4	F37-620H12/38-CFX**	31.8	66.6	78	95	91	83	100	30	1.01	420
1 1/2	F37-624-CFX	36.5	79.3	95	112	109	100	118	35	1.54	420
1 1/2	F37-624/38-CFX*	36.5	79.3	95	112	109	100	118	35	1.74	420
1 1/2	F37-624/42-CFX*	36.5	79.3	95	112	109	100	118	35	1.72	420
2	F37-632-CFX	44.5	96.8	114	134	129	119	139	40	2.44	420
2	F37-632/50-CFX*	44.5	96.8	114	134	129	119	139	40	2.76	420
2 1/2	F37-64073-CFX*	58.7	123.8	150	175	169	156	183	50	6.26	420

**Flange for size M12 bolts.

Parflange F37 threaded flange dimensions

* Jump size flanges (no adapter sleeves (SL...) necessary).

Size Inch	Flange Order code	A	B	G	H	M	N	O	L	Thread	Weight body (Steel) kg/1 piece	W.P. bar
1/2	F37-608T-CFX	18.2	40.5	48	56	57	53	61	20	M08	0.20	420
3/4	F37-612T-CFX	23.8	50.8	60	71	70	65	76	24	M10	0.35	420
3/4	F37-612/25T-CFX	23.8	50.8	60	71	70	65	76	24	M10	0.49	420
1	F37-616T-CFX	27.8	57.2	70	81	80	75	86	24	M12	0.57	420
1	F37-616/25T-CFX*	27.8	57.2	70	81	80	75	86	24	M12	0.68	420
1	F37-616/30T-CFX*	27.8	57.2	70	81	80	75	86	24	M12	0.63	420
1 1/4	F37-620T-CFX	31.8	66.6	78	95	91	83	100	30	M14	0.92	420
1 1/4	F37-620TM12-CFX**	31.8	66.6	78	95	91	83	100	30	M12	1.01	420
1 1/4	F37-620/38T-CFX*	31.8	66.6	78	95	91	83	100	30	M14	1.03	420
1 1/4	F37-620TM12/38-CFX**	31.8	66.6	78	95	91	83	100	30	M12	1.06	420
1 1/2	F37-624T-CFX	36.5	79.3	95	112	109	100	118	35	M16	1.64	420
1 1/2	F37-624/38T-CFX*	36.5	79.3	95	112	109	100	118	35	M16	1.82	420
2	F37-632T-CFX	44.5	96.8	114	134	129	119	139	40	M20	2.44	420

**Flange for size M12 bolts.

Pressure rates related to flanges. Other sizes / jump sizes on request.

Please change suffixes according to material/surface required

Order code suffixes			
Material	Suffix surface and material	Example	Comments
Steel, zinc plated, Cr(VI)-free	CF	F37-620-CFX	
Stainless steel	SS	F37-620-SSX	
Galvanized hot dip zinc	TZN	F37-620-TZNX	on request

Parflange® F37 – SAE 6000/ISO 6162-2

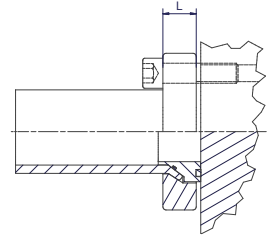
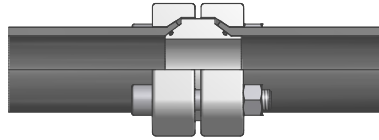

Part combination flaring SAE 6000

Flange Pressure (bar)	Size Inch	Pipe Size	Flange SAE 6000 ISO 6162-2	Insert*	Sleeve
420	1/2	16X2.0	F37-608-CFX	IN08-16X2.0T...	SL08-25-16-CFX
	1/2	18X2.0	F37-608-CFX	IN08-18X2.0T...	SL08-25-18-CFX
	1/2	20X2.0	F37-608-CFX	IN08-20X2.0T...	SL08-25-20-CFX
	1/2	20X2.5	F37-608-CFX	IN08-20X2.5T...	SL08-25-20-CFX
	1/2	25X2.5	F37-608-CFX	IN08-25X2.5T...	
	1/2	25X3.0	F37-608-CFX	IN08-25X3.0T...	
	3/4	20X2.0	F37-612-CFX	IN12-20X2.0T...	SL12-30-20-CFX
	3/4	20X2.5	F37-612-CFX	IN12-20X2.5T...	SL12-30-20-CFX
	3/4	25X2.5	F37-612-CFX	IN12-25X2.5T...	SL12-30-25-CFX**
	3/4	25X3.0	F37-612-CFX	IN12-25X3.0T...	SL12-30-25-CFX**
	3/4	30X3.0	F37-612-CFX	IN12-30X3.0T...	
	3/4	30X4.0	F37-612-CFX	IN12-30X4.0T...	
	1	25X2.5	F37-616-CFX	IN16-25X2.5T...	SL16-38-25-CFX**
	1	25X3.0	F37-616-CFX	IN16-25X3.0T...	SL16-38-25-CFX**
	1	30X3.0	F37-616-CFX	IN16-30X3.0T...	SL16-38-30-CFX**
	1	30X4.0	F37-616-CFX	IN16-30X4.0T...	SL16-38-30-CFX**
	1	38X2.5	F37-616-CFX	IN16-38X2.5T...	
	1	38X3.0	F37-616-CFX	IN16-38X3.0T...	
	1	38X4.0	F37-616-CFX	IN16-38X4.0T...	
	1	38X5.0	F37-616-CFX	IN16-38X5.0T...	
	1 1/4	30X3.0	F37-620-CFX***	IN20-30X3.0T...	SL20-42-30-CFX
	1 1/4	30X4.0	F37-620-CFX***	IN20-30X4.0T...	SL20-42-30-CFX
	1 1/4	38X3.0	F37-620-CFX***	IN20-38X3.0T...	SL20-42-38-CFX**
	1 1/4	38X4.0	F37-620-CFX***	IN20-38X4.0T...	SL20-42-38-CFX**
	1 1/4	38X5.0	F37-620-CFX***	IN20-38X5.0T...	SL20-42-38-CFX**
	1 1/4	42X3.0	F37-620-CFX***	IN20-42X3.0T...	
	1 1/4	42X4.0	F37-620-CFX***	IN20-42X4.0T...	
	1 1/2	38X3.0	F37-624-CFX	IN24-38X3.0T...	SL24-50-38-CFX**
	1 1/2	38X4.0	F37-624-CFX	IN24-38X4.0T...	SL24-50-38-CFX**
	1 1/2	38X5.0	F37-624-CFX	IN24-38X5.0T...	SL24-50-38-CFX**
	1 1/2	42X3.0	F37-624-CFX	IN24-42X3.0T...	SL24-50-42-CFX**
	1 1/2	42X4.0	F37-624-CFX	IN24-42X4.0T...	SL24-50-42-CFX**
1 1/2	50X3.0	F37-624-CFX	IN24-50X3.0T...		
1 1/2	50X5.0	F37-624-CFX	IN24-50X5.0T...		
1 1/2	50X6.0	F37-624-CFX	IN24-50X6.0T...		
2	50X3.0	F37-632-CFX	IN32-50X3.0T...	SL32-60-50-CFX**	
2	50X5.0	F37-632-CFX	IN32-50X5.0T...	SL32-60-50-CFX**	
2	50X6.0	F37-632-CFX	IN32-50X6.0T...	SL32-60-50-CFX**	
2	60X3.0	F37-632-CFX	IN32-60X3.0T...		
2	60X5.0	F37-632-CFX	IN32-60X5.0T...		
2	60X6.0	F37-632-CFX	IN32-60X6.0T...		

Select the complete version:

- * ...FBCF Bonded Seal version
- ...FVCF F37 Seal version
- ...TCF Tube to Tube version
- ...FCF Flat Face version

**Jump size flanges available alternatively to adapter sleeve, see page 109.

***Flanges for M12 bolts also available (F37-620H12-CFX).

Other sizes like schedule on request.

Bolts and nuts are not included in complete part numbers.

For recommended bolts and nuts see page 136.



R – Retaining ring flange | SAE 6000/ISO 6162-2 footprint

SAE 6000/ISO 6162-2

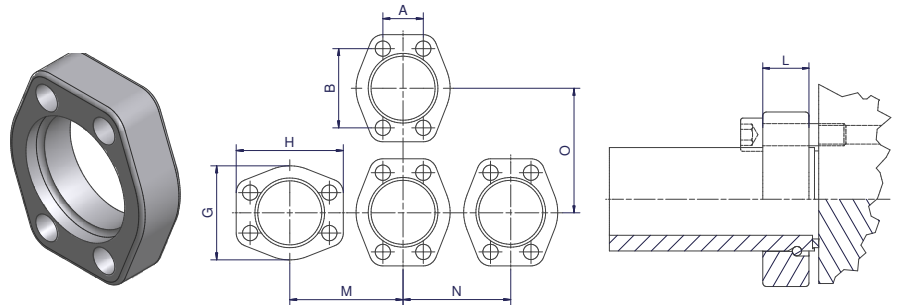

Retaining ring flange dimensions

Size Inch	Flange Order code	A	B	G	H	M	N	O	L	Weight body (Steel) kg/1 piece	W.P. bar
1/2	R-608-CFX	18.2	40.5	48	56	57	53	61	20	0.22	420
3/4	R-612-CFX	23.8	50.8	60	71	70	65	76	24	0.39	420
1	R-616-CFX	27.8	57.2	70	81	80	75	86	24	0.55	420
1 1/4	R-620-CFX	31.8	66.6	78	95	91	83	100	30	0.89	420
1 1/4	R-620H12-CFX*	31.8	66.6	78	95	91	83	100	30	0.92	420
1 1/2	R-624-CFX	36.5	79.3	95	112	109	100	118	35	1.46	420
2	R-632-CFX	44.5	96.8	114	134	129	119	139	40	2.35	420
2 1/2	R-640-CFX	58.7	123.8	150	176	169	156	183	50	5.96	420
3	R-648-CFX	71.4	152.4	176	212	202	184	218	52	8.41	420

*Flange for size M12 bolts.
 Pressure rates related to flanges.
 Other sizes like schedule on request.
 For all sizes also threaded flanges available (...T-CFX, R-620TM12-CFX).

Please change suffixes according to material/surface required

Order code suffixes			
Material	Suffix surface and material	Example	Comments
Steel, zinc plated, Cr(VI)-free	CF	R-620-CFX	
Stainless steel	SS	R-620-SSX	
Galvanized hot dip zinc	TZN	R-620-TZNX	on request

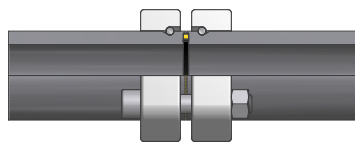

Part combination Bonded seal SAE 6000 connection

Flange pressure (bar)	Size Inch	Pipe Size	Flange	Retaining Ring	Bonded Seal
420	1/2	26X6.0	R-608-CFX	R08X	BS08SNX
	3/4	36X8.0	R-612-CFX	R12X	BS12SNX
	1	39X7.5	R-616-CFX	R16X	BS16SNX
	1 1/4	46X8.0	R-620-CFX	R20X	BS20SNX
	1 1/2	56X8.5	R-624-CFX	R24X	BS24SNX
	2	66X8.5	R-632-CFX	R32X	BS32SNX
	2 1/2	80X10.0	R-640-CFX	R40X	BS40SNX
3	97X12.0	R-648-CFX	R48X	BS48SNX	

For recommended bolts and nuts see page 136.

PSC – Pipe seal carrier | SAE 6000/ISO 6162-2 footprint

SAE 6000/ISO 6162-2

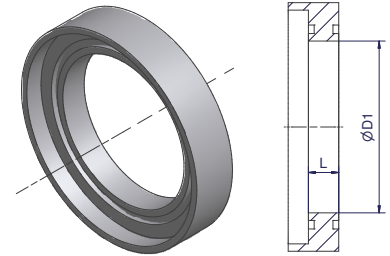

Size Inch	Pipe size	Seal carrier incl. F37 Seal	Seal carrier incl. O-Ring	L	D1	F37 Seal	O-Ring
1 1/4	46X8.0	PSC20-46X8.0VCF	PSC20-46X8.0OCF	8.0	30	F37RS20X	OR34.59X2.62X
1 1/2	56X8.5	PSC24-56X8.5VCF	PSC24-56X8.5OCF	10.0	39	F37RS24X	OR44.12X2.62X
2	66X8.5	PSC32-66X8.5VCF	PSC32-66X8.5OCF	10.0	49	F37RS32X	OR55.25X2.62X
2 1/2	80X10.0	PSC40-80X10VCF	PSC40-80X10OCF	15.0	60	F37RS40X	OR66.27X3.53X
3	97X12.0	PSC48-97X12VCF	PSC48-97X12OCF	15.0	73	F37RS48X	OR78.97X3.53X

Other sizes on request.

Please change suffixes according to material/surface required

Order code suffixes		
Material	Suffix surface and material	Example
Steel, zinc plated, Cr(VI)-free, F37-Seal	VCF	PSC40-80X10VCF
Stainless steel, F37-Seal	VSS	PSC40-80X10VSS
Steel, zinc plated, Cr(VI)-free, O-Ring (NBR)	OCF	PSC40-80X10OCF
Stainless steel, O-Ring (NBR)	OSS	PSC40-80X10OSS

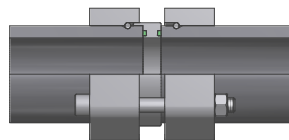

Example of Part combination Pipe seal carrier SAE 6000 connection

Flange pressure (bar)	Size Inch	Pipe Size	Flange	Retaining Ring	Seal Carrier
420	1 1/4	46X8.0	R-620-CFX or R-620H12-CFX	R20X	PSC20-46X8.0VCF
	1 1/2	56X8.5	R-624-CFX	R24X	PSC24-56X8.5VCF
	2	66X8.5	R-632-CFX	R32X	PSC32-66X8.5VCF
	2 1/2	80X10.0	R-640-CFX	R40X	PSC40-80X10VCF
	3	97X12.0	R-648-CFX	R48X	PSC48-97X12VCF

Other sizes on request.

Bolts and nuts are not included in complete part numbers. For recommended bolts and nuts see page 136.



TFB – Flare flange connection

Tube to port connection, bonded seal

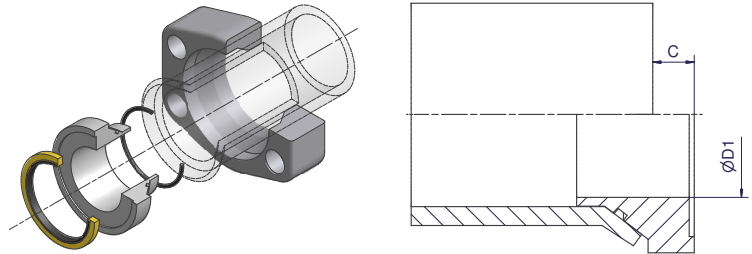

Size		Flange* incl. Insert + Bonded Seal + O-Ring Order code	D1	C	Insert incl. Bonded Seal + O-Ring Order code	Bonded Seal Order code	O-Ring Order code	Weight (Steel) kg/1 kit
Inch	Tube							
1/2	16X2.0	F37-608-16X2.0TFBCF	9.5	8.0	IN08-16X2.0TFBCF	BS08SNX	OR12X1.0X	0.24
1/2	18X2.0	F37-608-18X2.0TFBCF	11.5	8.0	IN08-18X2.0TFBCF	BS08SNX	OR14X1.0X	0.24
1/2	20X2.0	F37-608-20X2.0TFBCF	13.5	8.0	IN08-20X2.0TFBCF	BS08SNX	OR16X1.0X	0.24
1/2	20X2.5	F37-608-20x2.5TFBCF	13.5	8.0	IN08-20X2.5TFBCF	BS08SNX	OR16X1.0X	0.24
1/2	25X2.5	F37-608-25X2.5TFBCF	13.5	10.0	IN08-25X2.5TFBCF	BS08SNX	OR20X1.0X	0.25
1/2	25X3.0	F37-608-25X3.0TFBCF	13.0	8.0	IN08-25X3.0TFBCF	BS08SNX	OR20X1.0X	0.24
3/4	20X2.0	F37-612-20X2.0TFBCF	13.5	8.0	IN12-20X2.0TFBCF	BS12SNX	OR16X1.0X	0.41
3/4	20X2.5	F37-612-20X2.5TFBCF	12.5	8.0	IN12-20X2.5TFBCF	BS12SNX	OR16X1.0X	0.41
3/4	25X2.5	F37-612-25X2.5TFBCF	17.5	10.0	IN12-25X2.5TFBCF	BS12SNX	OR20X1.0X	0.41
3/4	25X3.0	F37-612-25X3.0TFBCF	16.5	8.0	IN12-25X3.0TFBCF	BS12SNX	OR20X1.0X	0.42
3/4	30X3.0	F37-612-30X3.0TFBCF	19.0	8.5	IN12-30X3.0TFBCF	BS12SNX	OR25X1.0X	0.42
3/4	30X4.0	F37-612-30X4.0TFBCF	19.5	8.5	IN12-30X4.0TFBCF	BS12SNX	OR22X1.0X	0.42
1	25X2.5	F37-616-25X2.5TFBCF	17.5	10.0	IN16-25X2.5TFBCF	BS16SNX	OR20X1.0X	0.62
1	25X3.0	F37-616-25X3.0TFBCF	16.5	8.0	IN16-25X3.0TFBCF	BS16SNX	OR20X1.0X	0.62
1	30X3.0	F37-616-30X3.0TFBCF	21.5	8.5	IN16-30X3.0TFBCF	BS16SNX	OR25X1.0X	0.62
1	30X4.0	F37-616-30X4.0TFBCF	19.5	8.5	IN16-30X4.0TFBCF	BS16SNX	OR22X1.0X	0.62
1	38X2.5	F37-616-38X2.5TFBCF	25.0	9.5	IN16-38X2.5TFBCF	BS16SNX	OR34X1.0X	0.64
1	38X3.0	F37-616-38X3.0TFBCF	25.0	9.0	IN16-38X3.0TFBCF	BS16SNX	OR34X1.0X	0.63
1	38X4.0	F37-616-38X4.0TFBCF	25.0	10.0	IN16-38X4.0TFBCF	BS16SNX	OR30X1.0X	0.63
1	38X5.0	F37-616-38X5.0TFBCF	25.0	8.0	IN16-38X5.0TFBCF	BS16SNX	OR28X1.0X	0.62
1 1/4	30X3.0	F37-620-30X3.0TFBCF**	21.5	8.5	IN20-30X3.0TFBCF	BS20SNX	OR25X1.0X	1.03
1 1/4	30X4.0	F37-620-30X4.0TFBCF**	19.5	8.5	IN20-30X4.0TFBCF	BS20SNX	OR22X1.0X	1.04
1 1/4	38X3.0	F37-620-38X3.0TFBCF**	29.5	9.0	IN20-38X3.0TFBCF	BS20SNX	OR34X1.0X	1.02
1 1/4	38X4.0	F37-620-38X4.0TFBCF**	27.0	10.0	IN20-38X4.0TFBCF	BS20SNX	OR30X1.0X	1.03
1 1/4	38X5.0	F37-620-38X5.0TFBCF**	25.5	8.0	IN20-38X5.0TFBCF	BS20SNX	OR28X1.0X	1.02
1 1/4	42X3.0	F37-620-42X3.0TFBCF**	31.5	10.0	IN20-42X3.0TFBCF	BS20SNX	OR37.82X1.78X	1.03
1 1/4	42X4.0	F37-620-42X4.0TFBCF**	31.5	10.0	IN20-42X4.0TFBCF	BS20SNX	OR34X1.0X	1.02
1 1/2	38X3.0	F37-624-38X3.0TFBCF	27.5	9.0	IN24-38X3.0TFBCF	BS24SNX	OR34X1.0X	1.11
1 1/2	38X4.0	F37-624-38X4.0TFBCF	27.5	10.0	IN24-38X4.0TFBCF	BS24SNX	OR30X1.0X	1.73
1 1/2	38X5.0	F37-624-38X5.0TFBCF	25.0	11.0	IN24-38X5.0TFBCF	BS24SNX	OR28X1.0X	1.73
1 1/2	42X3.0	F37-624-42X3.0TFBCF	35.0	10.0	IN24-42X3.0TFBCF	BS24SNX	OR37.82X1.78X	1.74
1 1/2	42X4.0	F37-624-42X4.0TFBCF	31.5	10.0	IN24-42X4.0TFBCF	BS24SNX	OR34X1.0X	1.73
1 1/2	50X3.0	F37-624-50X3.0TFBCF	36.0	11.0	IN24-50X3.0TFBCF	BS24SNX	OR44.17X1.78X	1.73
1 1/2	50X5.0	F37-624-50X5.0TFBCF	36.0	10.0	IN24-50X5.0TFBCF	BS24SNX	OR41X1.78X	1.73
1 1/2	50X6.0	F37-624-50X6.0TFBCF	35.0	10.0	IN24-50X6.0TFBCF	BS24SNX	OR41X1.78X	1.73
2	50X3.0	F37-632-50X3.0TFBCF	41.5	11.0	IN32-50X3.0TFBCF	BS32SNX	OR44.17X1.78X	2.66
2	50X5.0	F37-632-50X5.0TFBCF	37.5	10.0	IN32-50X5.0TFBCF	BS32SNX	OR41X1.78X	2.68
2	50X6.0	F37-632-50X6.0TFBCF	35.0	10.0	IN32-50X6.0TFBCF	BS32SNX	OR41X1.78X	2.71
2	60X3.0	F37-632-60X3.0TFBCF	46.0	12.0	IN32-60X3.0TFBCF	BS32SNX	OR53.7X1.78X	2.71
2	60X5.0	F37-632-60X5.0TFBCF	46.0	11.0	IN32-60X5.0TFBCF	BS32SNX	OR50.52X1.78X	2.68
2	60X6.0	F37-632-60X6.0TFBCF	45.5	11.0	IN32-60X6.0TFBCF	BS32SNX	OR47.37X1.78X	2.67

**Flanges for M12 bolts also available (F37-620H12-...TFBCF).
Other sizes on request. *Incl. adapter sleeve or jump size flange if necessary.
Please change suffixes according to material/surface required

Order code suffixes		
Material	Suffix surface and material	Example
Steel, zinc plated, Cr(VI)-free	CF	F37-624-50X5.0TFBCF
Stainless steel	SS	F37-624-50X5.0TFBSS

TFV – Flare flange connection

Tube to port connection, F37 seal

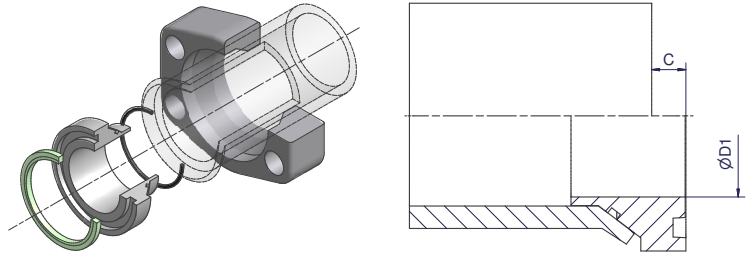

Size		Flange* incl. Insert + F37 Seal + O-Ring Order code	D1	C	Insert incl. F37 Seal + O-Ring Order code	F37 Seal Order code	O-Ring Order code	Weight (Steel) kg/1 kit
Inch	Tube							
1/2	16X2.0	F37-608-16X2.0TFVCF	9.5	8.0	IN08-16X2.0TFVCF	F37S08X	OR12X1.0X	0.24
1/2	18X2.0	F37-608-18X2.0TFVCF	11.5	8.0	IN08-18X2.0TFVCF	F37S08X	OR14X1.0X	0.24
1/2	20X2.0	F37-608-20X2.0TFVCF	13.5	8.0	IN08-20X2.0TFVCF	F37S08X	OR16X1.0X	0.24
1/2	20X2.5	F37-608-20X2.5TFVCF	13.5	8.0	IN08-20X2.5TFVCF	F37S08X	OR16X1.0X	0.24
1/2	25X2.5	F37-608-25X2.5TFVCF	13.5	10.0	IN08-25X2.5TFVCF	F37S08X	OR20X1.0X	0.25
1/2	25X3.0	F37-608-25X3.0TFVCF	13.0	8.0	IN08-25X3.0TFVCF	F37S08X	OR20X1.0X	0.24
3/4	20X2.0	F37-612-20X2.0TFVCF	13.5	8.0	IN12-20X2.0TFVCF	F37S12X	OR16X1.0X	0.41
3/4	20X2.5	F37-612-20X2.5TFVCF	12.5	8.0	IN12-20X2.5TFVCF	F37S12X	OR16X1.0X	0.41
3/4	25X2.5	F37-612-25X2.5TFVCF	17.5	10.0	IN12-25X2.5TFVCF	F37S12X	OR20X1.0X	0.41
3/4	25X3.0	F37-612-25X3.0TFVCF	16.5	8.0	IN12-25X3.0TFVCF	F37S12X	OR20X1.0X	0.42
3/4	30X3.0	F37-612-30X3.0TFVCF	19.0	8.5	IN12-30X3.0TFVCF	F37S12X	OR25X1.0X	0.42
3/4	30X4.0	F37-612-30X4.0TFVCF	19.5	8.5	IN12-30X4.0TFVCF	F37S12X	OR22X1.0X	0.42
1	25X2.5	F37-616-25X2.5TFVCF	17.5	10.0	IN16-25X2.5TFVCF	F37S16X	OR20X1.0X	0.61
1	25X3.0	F37-616-25X3.0TFVCF	16.5	8.0	IN16-25X3.0TFVCF	F37S16X	OR20X1.0X	0.62
1	30X3.0	F37-616-30X3.0TFVCF	21.5	8.5	IN16-30X3.0TFVCF	F37S16X	OR25X1.0X	0.64
1	30X4.0	F37-616-30X4.0TFVCF	19.5	8.5	IN16-30X4.0TFVCF	F37S16X	OR22X1.0X	0.62
1	38X2.5	F37-616-38X2.5TFVCF	25.0	9.5	IN16-38X2.5TFVCF	F37S16X	OR34X1.0X	0.64
1	38X3.0	F37-616-38X3.0TFVCF	25.0	9.0	IN16-38X3.0TFVCF	F37S16X	OR34X1.0X	0.63
1	38X4.0	F37-616-38X4.0TFVCF	25.0	10.0	IN16-38X4.0TFVCF	F37S16X	OR30X1.0X	0.63
1	38X5.0	F37-616-38X5.0TFVCF	25.0	8.0	IN16-38X5.0TFVCF	F37S16X	OR28X1.0X	0.62
1 1/4	30X3.0	F37-620-30X3.0TFVCF**	21.5	8.5	IN20-30X3.0TFVCF	F37S20X	OR25X1.0X	1.03
1 1/4	30X4.0	F37-620-30X4.0TFVCF**	19.5	8.5	IN20-30X4.0TFVCF	F37S20X	OR22X1.0X	1.04
1 1/4	38X3.0	F37-620-38X3.0TFVCF**	29.5	9.0	IN20-38X3.0TFVCF	F37S20X	OR34X1.0X	1.02
1 1/4	38X4.0	F37-620-38X4.0TFVCF**	27.0	10.0	IN20-38X4.0TFVCF	F37S20X	OR30X1.0X	1.03
1 1/4	38X5.0	F37-620-38X5.0TFVCF**	25.5	8.0	IN20-38X5.0TFVCF	F37S20X	OR28X1.0X	1.02
1 1/4	42X3.0	F37-620-42X3.0TFVCF**	31.5	10.0	IN20-42X3.0TFVCF	F37S20X	OR37.82X1.78X	1.03
1 1/4	42X4.0	F37-620-42X4.0TFVCF**	31.5	10.0	IN20-42X4.0TFVCF	F37S20X	OR34X1.0X	1.02
1 1/2	38X3.0	F37-624-38X3.0TFVCF	27.5	9.0	IN24-38X3.0TFVCF	F37S24X	OR34X1.0X	1.73
1 1/2	38X4.0	F37-624-38X4.0TFVCF	27.5	10.0	IN24-38X4.0TFVCF	F37S24X	OR30X1.0X	1.73
1 1/2	38X5.0	F37-624-38X5.0TFVCF	25.0	11.0	IN24-38X5.0TFVCF	F37S24X	OR28X1.0X	1.73
1 1/2	42X3.0	F37-624-42X3.0TFVCF	33.5	10.0	IN24-42X3.0TFVCF	F37S24X	OR37.82X1.78X	1.73
1 1/2	42X4.0	F37-624-42X4.0TFVCF	31.5	10.0	IN24-42X4.0TFVCF	F37S24X	OR34X1.0X	1.73
1 1/2	50X3.0	F37-624-50X3.0TFVCF	36.0	11.0	IN24-50X3.0TFVCF	F37S24X	OR44.17X1.78X	1.73
1 1/2	50X5.0	F37-624-50X5.0TFVCF	36.0	10.0	IN24-50X5.0TFVCF	F37S24X	OR41X1.78X	1.73
1 1/2	50X6.0	F37-624-50X6.0TFVCF	35.0	10.0	IN24-50X6.0TFVCF	F37S24X	OR41X1.78X	1.73
2	50X3.0	F37-632-50X3.0TFVCF	41.5	11.0	IN32-50X3.0TFVCF	F37S32X	OR44.17X1.78X	2.66
2	50X5.0	F37-632-50X5.0TFVCF	37.5	10.0	IN32-50X5.0TFVCF	F37S32X	OR41X1.78X	2.68
2	50X6.0	F37-632-50X6.0TFVCF	35.0	10.0	IN32-50X6.0TFVCF	F37S32X	OR41X1.78X	2.71
2	60X3.0	F37-632-60X3.0TFVCF	46.0	12.0	IN32-60X3.0TFVCF	F37S32X	OR53.7X1.78X	2.71
2	60X5.0	F37-632-60X5.0TFVCF	46.0	11.0	IN32-60X5.0TFVCF	F37S32X	OR50.52X1.78X	2.68
2	60X6.0	F37-632-60X6.0TFVCF	45.5	11.0	IN32-60X6.0TFVCF	F37S32X	OR47.37X1.78X	2.67

**Flanges for M12 bolts also available (F37-620H12-...TFVCF).

Other sizes on request. *Incl. adapter sleeve or jump size flange if necessary.

Please change suffixes according to material/surface required

Order code suffixes		
Material	Suffix surface and material	Example
Steel, zinc plated, Cr(VI)-free	CF	F37-624-50X5.0TFVCF
Stainless steel	SS	F37-624-50X5.0TFVSS



TT – Flare flange connection

Tube to tube connection

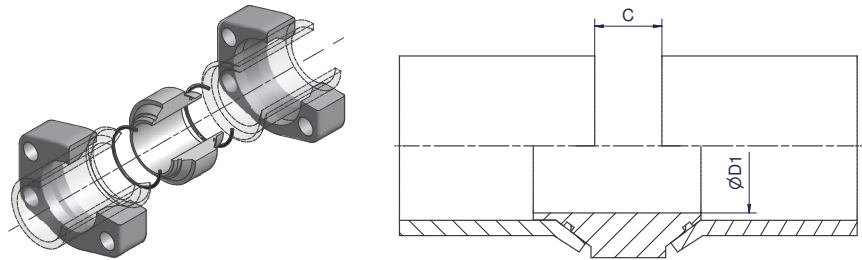

Size		2 x Flanges* incl. Insert + 2 x O-Ring Order code	D1	C	Insert incl. 2 x O-Ring Order code	O-Ring Order code	Weight (Steel) kg/1 kit
Inch	Tube						
1/2	16X2.0	F37-608-16X2.0TTCF	9.5	16	IN08-16X2.0TTCF	OR12X1.0X	0.28
1/2	18X2.0	F37-608-18X2.0TTCF	11.5	16	IN08-18X2.0TTCF	OR14X1.0X	0.29
1/2	20X2.0	F37-608-20X2.0TTCF	13.5	16	IN08-20X2.0TTCF	OR16X1.0X	0.29
1/2	20X2.5	F37-608-20X2.5TTCF	13.5	16	IN08-20X2.5TTCF	OR16X1.0X	0.29
1/2	25X2.5	F37-608-25X2.5TTCF	13.5	20	IN08-25X2.5TTCF	OR20X1.0X	0.30
1/2	25X3.0	F37-608-25X3.0TTCF	13.5	16	IN08-25X3.0TTCF	OR20X1.0X	0.29
3/4	20X2.0	F37-612-20X2.0TTCF	13.5	16	IN12-20X2.0TTCF	OR16X1.0X	0.48
3/4	20X2.5	F37-612-20X2.5TTCF	12.5	16	IN12-20X2.5TTCF	OR16X1.0X	0.48
3/4	25X2.5	F37-612-25X2.5TTCF	17.5	20	IN12-25X2.5TTCF	OR20X1.0X	0.49
3/4	25X3.0	F37-612-25X3.0TTCF	16.5	16	IN12-25X3.0TTCF	OR20X1.0X	0.49
3/4	30X3.0	F37-612-30X3.0TTCF	19.0	17	IN12-30X3.0TTCF	OR25X1.0X	0.50
3/4	30X4.0	F37-612-30X4.0TTCF	19.5	17	IN12-30X4.0TTCF	OR22X1.0X	0.50
1	25X2.5	F37-616-25X2.5TTCF	17.5	20	IN16-25X2.5TTCF	OR20X1.0X	0.72
1	25X3.0	F37-616-25X3.0TTCF	16.5	16	IN16-25X3.0TTCF	OR20X1.0X	0.72
1	30X3.0	F37-616-30X3.0TTCF	21.5	17	IN16-30X3.0TTCF	OR25X1.0X	0.71
1	30X4.0	F37-616-30X4.0TTCF	19.5	17	IN16-30X4.0TTCF	OR22X1.0X	0.72
1	38X2.5	F37-616-38X2.5TTCF	25.0	19	IN16-38X2.5TTCF	OR34X1.0X	0.77
1	38X3.0	F37-616-38X3.0TTCF	25.0	18	IN16-38X3.0TTCF	OR34X1.0X	0.75
1	38X4.0	F37-616-38X4.0TTCF	25.0	20	IN16-38X4.0TTCF	OR30X1.0X	0.73
1	38X5.0	F37-616-38X5.0TTCF	25.0	16	IN16-38X5.0TTCF	OR28X1.0X	0.71
1 1/4	30X3.0	F37-620-30X3.0TTCF**	21.5	17	IN20-30X3.0TTCF	OR25X1.0X	1.16
1 1/4	30X4.0	F37-620-30X4.0TTCF**	19.5	17	IN20-30X4.0TTCF	OR22X1.0X	1.19
1 1/4	38X3.0	F37-620-38X3.0TTCF**	25.0	18	IN20-38X3.0TTCF	OR34X1.0X	1.14
1 1/4	38X4.0	F37-620-38X4.0TTCF**	27.0	20	IN20-38X4.0TTCF	OR30X1.0X	1.15
1 1/4	38X5.0	F37-620-38X5.0TTCF**	25.5	16	IN20-38X5.0TTCF	OR28X1.0X	1.13
1 1/4	42X3.0	F37-620-42X3.0TTCF**	31.5	20	IN20-42X3.0TTCF	OR37.82X1.78X	1.14
1 1/4	42X4.0	F37-620-42X4.0TTCF**	31.5	20	IN20-42X4.0TTCF	OR34X1.0X	1.13
1 1/2	38X3.0	F37-624-38X3.0TTCF	27.5	18	IN24-38X3.0TTCF	OR34X1.0X	1.79
1 1/2	38X4.0	F37-624-38X4.0TTCF	27.5	20	IN24-38X4.0TTCF	OR30X1.0X	1.79
1 1/2	38X5.0	F37-624-38X5.0TTCF	25.0	22	IN24-38X5.0TTCF	OR28X1.0X	1.79
1 1/2	42X3.0	F37-624-42X3.0TTCF	33.5	20	IN24-42X3.0TTCF	OR37.82X1.78X	1.84
1 1/2	42X4.0	F37-624-42X4.0TTCF	31.5	20	IN24-42X4.0TTCF	OR34X1.0X	1.94
1 1/2	50X3.0	F37-624-50X3.0TTCF	36.0	22	IN24-50X3.0TTCF	OR44.17X1.78X	1.96
1 1/2	50X5.0	F37-624-50X5.0TTCF	36.0	20	IN24-50X5.0TTCF	OR41X1.78X	2.07
1 1/2	50X6.0	F37-624-50X6.0TTCF	35.0	20	IN24-50X6.0TTCF	OR41X1.78X	1.96
2	50X3.0	F37-632-50X3.0TTCF	41.5	22	IN32-50X3.0TTCF	OR44.17X1.78X	2.86
2	50X5.0	F37-632-50X5.0TTCF	37.5	20	IN32-50X5.0TTCF	OR41X1.78X	2.97
2	50X6.0	F37-632-50X6.0TTCF	35.0	20	IN32-50X6.0TTCF	OR41X1.78X	3.02
2	60X3.0	F37-632-60X3.0TTCF	46.0	24	IN32-60X3.0TTCF	OR53.7X1.78X	2.99
2	60X5.0	F37-632-60X5.0TTCF	46.0	22	IN32-60X5.0TTCF	OR50.52X1.78X	2.92
2	60X6.0	F37-632-60X6.0TTCF	45.5	22	IN32-60X6.0TTCF	OR47.37X1.78X	2.91

**Flanges for M12 bolts also available (F37-620H12-...TTCF).
Other sizes on request. *Incl. adapter sleeve or jump size flange if necessary.
Please change suffixes according to material/surface required

Order code suffixes		
Material	Suffix surface and material	Example
Steel, zinc plated, Cr(VI)-free	CF	F37-624-50X5.0TTCF
Stainless steel	SS	F37-624-50X5.0TTSS

TF – Flare flange connection

Tube to port connection, flat face

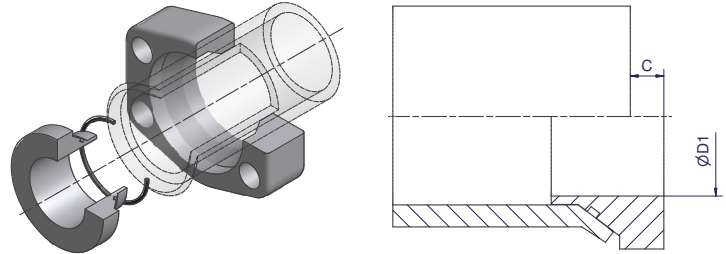

Size		Flange* incl. Insert + O-Ring Order code	D1	C	Insert incl. O-Ring Order code	O-Ring Order code	Weight (Steel) kg/1 kit
Inch	Tube						
1/2	16X2.0	F37-608-16X2.0TFCF	9.5	8.0	IN08-16X2.0TFCF	OR12X1.0X	0.24
1/2	18X2.0	F37-608-18X2.0TFCF	11.5	8.0	IN08-18X2.0TFCF	OR14X1.0X	0.24
1/2	20X2.0	F37-608-20X2.0TFCF	13.5	8.0	IN08-20X2.0TFCF	OR16X1.0X	0.25
1/2	20X2.5	F37-608-20X2.5TFCF	13.5	8.0	IN08-20X2.5TFCF	OR16X1.0X	0.25
1/2	25X2.5	F37-608-25X2.5TFCF	13.5	10.0	IN08-25X2.5TFCF	OR20X1.0X	0.25
1/2	25X3.0	F37-608-25X3.0TFCF	13.0	8.0	IN08-25X3.0TFCF	OR20X1.0X	0.24
3/4	20X2.0	F37-612-20X2.0TFCF	13.5	8.0	IN12-20X2.0TFCF	OR16X1.0X	0.41
3/4	20X2.5	F37-612-20X2.5TFCF	12.5	8.0	IN12-20X2.5TFCF	OR16X1.0X	0.41
3/4	25X2.5	F37-612-25X2.5TFCF	17.5	10.0	IN12-25X2.5TFCF	OR20X1.0X	0.41
3/4	25X3.0	F37-612-25X3.0TFCF	16.5	8.0	IN12-25X3.0TFCF	OR20X1.0X	0.42
3/4	30X3.0	F37-612-30X3.0TFCF	19.0	8.5	IN12-30X3.0TFCF	OR25X1.0X	0.42
3/4	30X4.0	F37-612-30X4.0TFCF	19.5	8.5	IN12-30X4.0TFCF	OR22X1.0X	0.42
1	25X2.5	F37-616-25X2.5TFCF	17.5	10.0	IN16-25X2.5TFCF	OR20X1.0X	0.61
1	25X3.0	F37-616-25X3.0TFCF	16.5	8.0	IN16-25X3.0TFCF	OR20X1.0X	0.62
1	30X3.0	F37-616-30X3.0TFCF	21.5	8.5	IN16-30X3.0TFCF	OR25X1.0X	0.64
1	30X4.0	F37-616-30X4.0TFCF	19.5	8.5	IN16-30X4.0TFCF	OR22X1.0X	0.62
1	38X2.5	F37-616-38X2.5TFCF	25.0	9.5	IN16-38X2.5TFCF	OR34X1.0X	0.64
1	38X3.0	F37-616-38X3.0TFCF	25.0	9.0	IN16-38X3.0TFCF	OR34X1.0X	0.63
1	38X4.0	F37-616-38X4.0TFCF	25.0	10.0	IN16-38X4.0TFCF	OR30X1.0X	0.63
1	38X5.0	F37-616-38X5.0TFCF	25.0	8.0	IN16-38X5.0TFCF	OR28X1.0X	0.62
1 1/4	30X3.0	F37-620-30X3.0TFCF**	21.5	8.5	IN20-30X3.0TFCF	OR25X1.0X	1.03
1 1/4	30X4.0	F37-620-30X4.0TFCF**	19.5	8.5	IN20-30X4.0TFCF	OR22X1.0X	1.05
1 1/4	38X3.0	F37-620-38X3.0TFCF**	29.0	9.0	IN20-38X3.0TFCF	OR34X1.0X	1.02
1 1/4	38X4.0	F37-620-38X4.0TFCF**	27.0	10.0	IN20-38X4.0TFCF	OR30X1.0X	1.03
1 1/4	38X5.0	F37-620-38X5.0TFCF**	25.5	8.0	IN20-38X5.0TFCF	OR28X1.0X	1.02
1 1/4	42X3.0	F37-620-42X3.0TFCF**	31.5	10.0	IN20-42X3.0TFCF	OR37.82X1.78X	1.03
1 1/4	42X4.0	F37-620-42X4.0TFCF**	31.5	10.0	IN20-42X4.0TFCF	OR34X1.0X	1.02
1 1/2	38X3.0	F37-624-38X3.0TFCF	27.5	9.0	IN24-38X3.0TFCF	OR34X1.0X	1.73
1 1/2	38X4.0	F37-624-38X4.0TFCF	27.5	10.0	IN24-38X4.0TFCF	OR30X1.0X	1.73
1 1/2	38X5.0	F37-624-38X5.0TFCF	25.0	11.0	IN24-38X5.0TFCF	OR28X1.0X	1.73
1 1/2	42X3.0	F37-624-42X3.0TFCF	33.5	10.0	IN24-42X3.0TFCF	OR37.82X1.78X	1.73
1 1/2	42X4.0	F37-624-42X4.0TFCF	31.5	10.0	IN24-42X4.0TFCF	OR34X1.0X	1.73
1 1/2	50X3.0	F37-624-50X3.0TFCF	36.0	11.0	IN24-50X3.0TFCF	OR44.17X1.78X	1.73
1 1/2	50X5.0	F37-624-50X5.0TFCF	36.0	10.0	IN24-50X5.0TFCF	OR41X1.78X	1.73
1 1/2	50X6.0	F37-624-50X6.0TFCF	35.0	10.0	IN24-50X6.0TFCF	OR41X1.78X	1.73
2	50X3.0	F37-632-50X3.0TFCF	41.5	11.0	IN32-50X3.0TFCF	OR44.17X1.78X	2.66
2	50X5.0	F37-632-50X5.0TFCF	37.5	10.0	IN32-50X5.0TFCF	OR41X1.78X	2.68
2	50X6.0	F37-632-50X6.0TFCF	35.0	10.0	IN32-50X6.0TFCF	OR41X1.78X	2.71
2	60X3.0	F37-632-60X3.0TFCF	46.0	12.0	IN32-60X3.0TFCF	OR53.7X1.78X	2.71
2	60X5.0	F37-632-60X5.0TFCF	46.0	11.0	IN32-60X5.0TFCF	OR50.52X1.78X	2.68
2	60X6.0	F37-632-60X6.0TFCF	45.5	11.0	IN32-60X6.0TFCF	OR47.37X1.78X	2.67

**Flanges for M12 bolts also available (F37-620H12-...TFCF).
Other sizes on request. *Incl. adapter sleeve or jump size flange if necessary.
Please change suffixes according to material/surface required

Order code suffixes		
Material	Suffix surface and material	Example
Steel, zinc plated, Cr(VI)-free	CF	F37-624-50X5.0TFCF
Stainless steel	SS	F37-624-50X5.0TFSS



SL – Sleeve

SAE 6000/ISO 6162-2

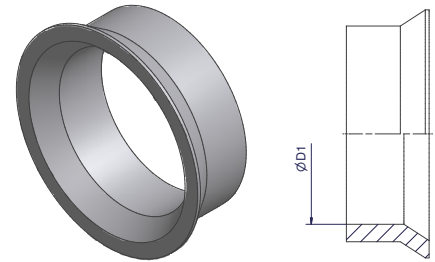

Size Inch	Tube OD	Order code	D1	Weight body (Steel) kg/1 piece
1/2	16	SL08-25-16-CFX	16.3	0.04
1/2	18	SL08-25-18-CFX	18.3	0.04
1/2	20	SL08-25-20-CFX	20.3	0.04
3/4	20	SL12-30-20-CFX	20.3	0.04
3/4	25	SL12-30-25-CFX*	25.2	0.04
1	25	SL16-38-25-CFX*	25.2	0.04
1	30	SL16-38-30-CFX*	30.2	0.04
1 1/4	30	SL20-42-30-CFX	30.2	0.04
1 1/4	38	SL20-42-38-CFX*	38.3	0.04
1 1/2	38	SL24-50-38-CFX*	38.3	0.14
1 1/2	42	SL24-50-42-CFX*	42.3	0.10
2	50	SL32-60-50-CFX*	50.3	0.16

*By use of jump size flanges, no adapter sleeves necessary. For jump size flanges see page 103.

Please change suffixes according to material/surface required

Order code suffixes		
Material	Suffix surface and material	Example
Steel, zinc plated, Cr(VI)-free	CF	SL24-50-42-CFX
Stainless steel	SS	SL24-50-42-SSX

R – Retaining ring

SAE 6000/ISO 6162-2

Size Inch	Tube	Order code	D	S
1/2	26X6.0	R08X	22.3	4.0
3/4	36X8.0	R12X	32.3	4.0
1	39X7.5	R16X	34.3	5.0
1 1/4	46X8.0	R20X	41.3	5.0
1 1/2	56X8.5	R24X	51.3	5.0
2	66X8.5	R32X	61.3	5.0
2 1/2	80X10.0	R40X	75.3	5.0
3	97X12.0	R48X	91.3	6.0

Material: Stainless steel

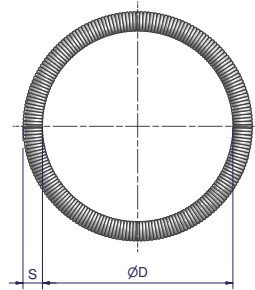

MTF-R – Male thread adapter, BSPP

SAE 6000/ISO 6162-2

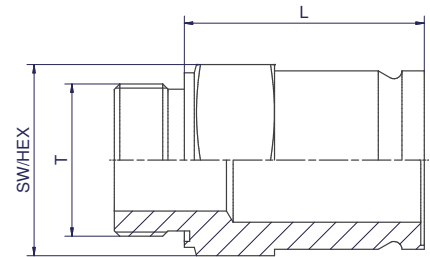
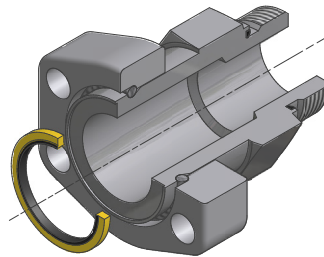

Size Inch	Tube	Complete part Order code	Body incl. ED Seal Order code	L	T (BSPP)	SW/ HEX	Weight body (Steel) kg/1 piece
1/2	26X6.0	R-608MTFRCF	MTF08ROMDCF	61.0	G 1/2 A	27	0.21
3/4	36X8.0	R-612MTFRCF	MTF12ROMDCF	61.0	G 3/4 A	36	0.32
3/4	36X8.0	R-612MTFR1/2CF	MTF12R1/2OMDCF	61.0	G 1/2 A	36	0.32
1	39X7.5	R-616MTFRCF	MTF16ROMDCF	69.0	G 1 A	41	0.50
1	39X7.5	R-616MTFR3/4CF	MTF16R3/4OMDCF	69.0	G 3/4 A	41	0.50
1 1/4	46X8.0	R-620MTFRCF	MTF20ROMDCF	80.0	G 1 1/4 A	50	0.75
1 1/4	46X8.0	R-620MTFR1CF	MTF20R1OMDCF	80.0	G 1 A	50	0.73
1 1/2	56X8.5	R-624MTFRCF	MTF24ROMDCF	93.0	G 1 1/2 A	60	1.20
1 1/2	56X8.5	R-624MTFR11/4CF	MTF24R11/4OMDCF	93.0	G 1 1/4 A	60	1.17
2	66X8.5	R-632MTFRCF	MTF32ROMDCF	104.0	G 2 A	75	1.87
2	66X8.5	R-632MTFR11/2CF	MTF32R11/2OMDCF	103.5	G 1 1/2 A	75	1.80
2 1/2	80X10.0	R-640MTFRCF	MTF40ROMDCF	134.0	G 2 1/2 A	85	3.50
2 1/2	80X10.0	R-640MTFR2CF	MTF40R2OMDCF	136.0	G 2 A	85	3.50
3	97X12.0	R-648MTFRCF	MTF48ROMDCF	145.0	G 3 A	95	5.00

Other sizes on request.

Please change suffixes according to material/surface required

Order code suffixes		
Material	Suffix surface and material	Example
Steel, zinc plated, Cr(VI)-free	CF	R-620MTFROMDCF
Stainless steel	SS	R-620MTFROMDSS

MTF-N – Male thread adapter, NPT

SAE 6000/ISO 6162-2

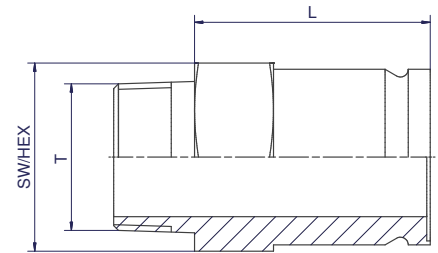
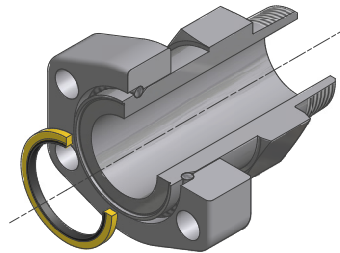

Size Inch	Tube	Complete part Order code	Body Order code	L	T (NPT)	SW/HEX	Weight body (Steel) kg/1 piece
1/2	26X6.0	R-608MTFNCF	MTF08NCFX	72.6	1/2-14	27	0.26
3/4	36X8.0	R-612MTFNCF	MTF12NCFX	72.6	3/4-14	36	0.48
1	39X7.5	R-616MTFNCF	MTF16NCFX	67.7	1-11.5	41	0.55
1 1/4	46X8.0	R-620MTFNCF	MTF20NCFX	75.0	1 1/4-11.5	50	0.70
1 1/2	56X8.5	R-624MTFNCF	MTF24NCFX	93.2	1 1/2-11.5	60	1.80
2	66X8.5	R-632MTFNCF	MTF32NCFX	100.4	2-11.5	75	2.40
2 1/2	80X10.0	R-640MTFNCF	MTF40NCFX	130.0	2 1/2-8	85	3.40
3	97X12.0	R-648MTFNCF	MTF48NCFX	141.2	3-8	95	4.90

Other sizes on request.

Please change suffixes according to material/surface required

Order code suffixes		
Material	Suffix surface and material	Example
Steel, zinc plated, Cr(VI)-free	CF	R-620MT0NCF
Stainless steel	SS	R-620MTFNSS



FTF-R – Female thread adapter, BSPP

SAE 6000/ISO 6162-2

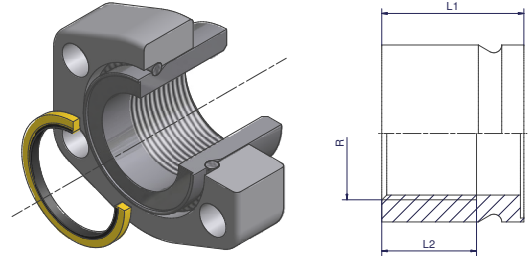

Size Inch	Tube	Complete part Order code	Body Order code	L1	L2	R (BSPP)	Weight body (Steel) kg/1 piece
1/2	26X6.0	R-608FTFRCF	FTF08RCFX	35	25	G 1/4	0.11
3/4	36X8.0	R-612FTFRCF	FTF12RCFX	40	25	G 1/2	0.22
1	39X7.5	R-616FTFRCF	FTF16RCFX	40	25	G 3/4	0.20
1 1/4	46X8.0	R-620FTFRCF	FTF20RCFX	42	30	G 1	0.30
1 1/2	56X8.5	R-624FTFRCF	FTF24RCFX	45	30	G 1 1/4	0.45
2	66X8.5	R-632FTFRCF	FTF32RCFX	55	40	G 1 1/2	0.75
2 1/2	80X10.0	R-640FTFRCF	FTF40RCFX	80	40	G 2	1.52
3	97X12.0	R-648FTFRCF	FTF48RCFX	85	50	G 2 1/2	2.11

Other sizes on request.

Please change suffixes according to material/surface required

Order code suffixes		
Material	Suffix surface and material	Example
Steel, zinc plated, Cr(VI)-free	CF	R-620FTFRCF
Stainless steel	SS	R-620FTFRSS

Retaining ring hose couplings

SAE 3000/ISO 6162-1 or ISO 6162-2

X5 and K5 Flange - Straight

Full flange system for ISO 6162-1 or ISO 6162-2

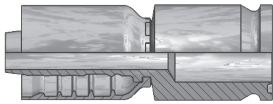

1X577-...



KX5V6-...

X7 and K7 Flange - 45° Elbow

Full flange system for ISO 6162-1 or ISO 6162-2

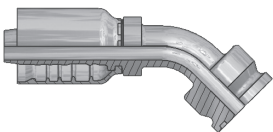

1X777-...



KX7V6-...

X9 and K9 Flange - 90° Elbow

Full flange system for ISO 6162-1 or ISO 6162-2

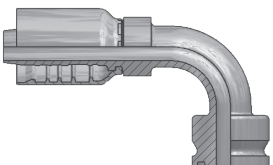

1X977-...

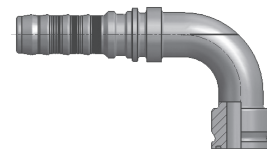

KX9V6-...

Details about hose fittings and the associated hose types can be found in the catalog of PHDE CAT/4400/UK.

WA – Weld adapter connection

SAE 6000/ISO 6162-2

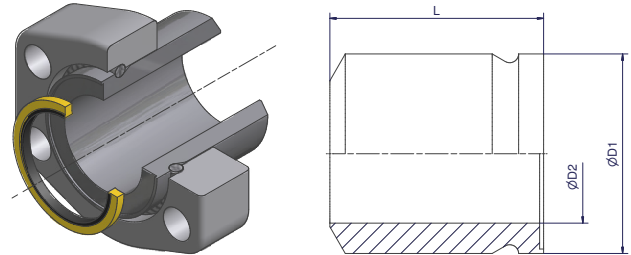

Size Inch	Tube	Complete Part Order code	Retaining Ring	Bonded Seal	Flange Order code	Weld Adapter Body Order code	D1	D2	L	Weight (Steel) kg/1 kit
1/2	12X1.5	R-608WA-12X1.5S	R08X	BS08SNX	R-608-CFX	WA08-12X1.5SX	26	14	40	0.29
1/2	16X2.0	R-608WA-16X2.0S	R08X	BS08SNX	R-608-CFX	WA08-16X2.0SX	26	14	40	0.30
1/2	18X2.0	R-608WA-18X2.0S	R08X	BS08SNX	R-608-CFX	WA08-18X2.0SX	26	14	40	0.30
1/2	20X2.0	R-608WA-20X2.5S	R08X	BS08SNX	R-608-CFX	WA08-20X2.5SX	26	14	40	0.30
1/2	21.3X2.1	R-608WA-21.3X2.1S	R08X	BS08SNX	R-608-CFX	WA08-21.3X2.1SX	26	14	40	0.30
1/2	21.3X2.8	R-608WA-21.3X2.8S	R08X	BS08SNX	R-608-CFX	WA08-21.3X2.8SX	26	14	40	0.30
1/2	21.3X3.7	R-608WA-21.3X3.7S	R08X	BS08SNX	R-608-CFX	WA08-21.3X3.7SX	26	14	45	0.31
1/2	21.3X4.8	R-608WA-21.3X4.8S	R08X	BS08SNX	R-608-CFX	WA08-21.3X4.8SX	26	14	45	0.32
1/2	21.3X7.5	R-608WA-21.3X7.5S	R08X	BS08SNX	R-608-CFX	WA08-21.3X7.5SX	26	14	45	0.32
1/2	25X2.5	R-608WA-25X2.5S	R08X	BS08SNX	R-608-CFX	WA08-25X2.5SX	26	14	40	0.29
1/2	26X6.0	R-608WA-26X6.0S	R08X	BS08SNX	R-608-CFX	WA08-26X6.0SX	26	14	40	0.31
3/4	20X2.5	R-612WA-20X2.5S	R12X	BS12SNX	R-612-CFX	WA12-20X2.5SX	36	20	45	0.41
3/4	25X3.0	R-612WA-25X3.0S	R12X	BS12SNX	R-612-CFX	WA12-25X3.0SX	36	20	45	0.41
3/4	26.7X2.1	R-612WA-26.7X2.1S	R12X	BS12SNX	R-612-CFX	WA12-26.7X2.1SX	36	20	45	0.40
3/4	26.7X2.8	R-612WA-26.7X2.8S	R12X	BS12SNX	R-612-CFX	WA12-26.7X2.8SX	36	20	45	0.41
3/4	26.7X3.9	R-612WA-26.7X3.9S	R12X	BS12SNX	R-612-CFX	WA12-26.7X3.9SX	36	20	45	0.41
3/4	26.7X5.6	R-612WA-26.7X5.6S	R12X	BS12SNX	R-612-CFX	WA12-26.7X5.6SX	36	20	50	0.44
3/4	26.7X7.8	R-612WA-26.7X7.8S	R12X	BS12SNX	R-612-CFX	WA12-26.7X7.8SX	36	20	50	0.45
3/4	30X3.0	R-612WA-30X3.0S	R12X	BS12SNX	R-612-CFX	WA12-30X3.0SX	36	20	50	0.41
3/4	30X4.0	R-612WA-30X4.0S	R12X	BS12SNX	R-612-CFX	WA12-30X4.0SX	36	20	50	0.42
3/4	30X6.0	R-612WA-30X6.0S	R12X	BS12SNX	R-612-CFX	WA12-30X6.0SX	36	20	50	0.44
3/4	36X8.0	R-612WA-36X8.0S	R12X	BS12SNX	R-612-CFX	WA12-36X8.0SX	36	20	50	0.46
1	25X3.0	R-616WA-25X3.0S	R16X	BS16SNX	R-616-CFX	WA16-25X3.0SX	39	19	60	0.66
1	30X4.0	R-616WA-30X4.0S	R16X	BS16SNX	R-616-CFX	WA16-30X4.0SX	39	20	60	0.65
1	33.4X2.8	R-616WA-33.4X2.8S	R16X	BS16SNX	R-616-CFX	WA16-33.4X2.8SX	39	24	60	0.61
1	33.4X3.4	R-616WA-33.4X3.4S	R16X	BS16SNX	R-616-CFX	WA16-33.4X3.4SX	39	24	60	0.62
1	33.4X4.6	R-616WA-33.4X4.6S	R16X	BS16SNX	R-616-CFX	WA16-33.4X4.6SX	39	24	60	0.64
1	33.4X6.5	R-616WA-33.4X6.5S	R16X	BS16SNX	R-616-CFX	WA16-33.4X6.5SX	39	20	60	0.70
1	33.4X9.1	R-616WA-33.4X9.1S	R16X	BS16SNX	R-616-CFX	WA16-33.4X9.1SX	39	24	60	0.69
1	38X4.0	R-616WA-38X4.0S	R16X	BS16SNX	R-616-CFX	WA16-38X4.0SX	39	24	55	0.59
1	38X5.0	R-616WA-38X5.0S	R16X	BS16SNX	R-616-CFX	WA16-38X5.0SX	39	24	55	0.61
1	38X7.0	R-616WA-38X7.0S	R16X	BS16SNX	R-616-CFX	WA16-38X7.0SX	39	24	60	0.67
1	39X7.5	R-616WA-39X7.5S	R16X	BS16SNX	R-616-CFX	WA16-39X7.5SX	39	24	50	0.62
1 1/4	30X4.0	R-620WA-30X4.0S	R20X	BS20SNX	R-620-CFX	WA20-30X4.0SX	46	22	70	1.06
1 1/4	38X4.0	R-620WA-38X4.0S	R20X	BS20SNX	R-620-CFX	WA20-38X4.0SX	46	30	65	0.91
1 1/4	38X5.0	R-620WA-38X5.0S	R20X	BS20SNX	R-620-CFX	WA20-38X5.0SX	46	28	65	0.96
1 1/4	42X3.0	R-620WA-42X3.0S	R20X	BS20SNX	R-620-CFX	WA20-42X3.0SX	46	30	65	0.86
1 1/4	42X4.0	R-620WA-42X4.0S	R20X	BS20SNX	R-620-CFX	WA20-42X4.0SX	46	30	65	0.89
1 1/4	42X6.0	R-620WA-42X6.0S	R20X	BS20SNX	R-620-CFX	WA20-42X6.0SX	46	30	65	0.95
1 1/4	42.2X2.7	R-620WA-42.2X2.7S	R20X	BS20SNX	R-620-CFX	WA20-42.2X2.7SX	46	30	65	0.85
1 1/4	42.2X3.6	R-620WA-42.2X3.6S	R20X	BS20SNX	R-620-CFX	WA20-42.2X3.6SX	46	30	65	0.88
1 1/4	42.2X4.9	R-620WA-42.2X4.9S	R20X	BS20SNX	R-620-CFX	WA20-42.2X4.9SX	46	30	65	0.92
1 1/4	42.2X6.4	R-620WA-42.2X6.4S	R20X	BS20SNX	R-620-CFX	WA20-42.2X6.4SX	46	29	65	0.96
1 1/4	42.2X9.7	R-620WA-42.2X9.7S	R20X	BS20SNX	R-620-CFX	WA20-42.2X9.7SX	46	23	65	1.08
1 1/4	46X7.0	R-620WA-46X7.0S	R20X	BS20SNX	R-620-CFX	WA20-46X7.0SX	46	30	65	0.97
1 1/4	46X8.0	R-620WA-46X8.0S	R20X	BS20SNX	R-620-CFX	WA20-46X8.0SX	46	30	55	0.90

See next page

WA – Weld adapter connection continued

SAE 6000/ISO 6162-2

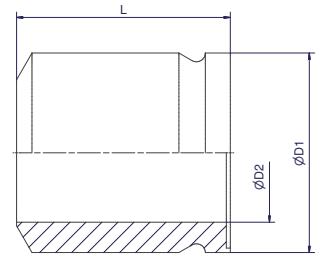
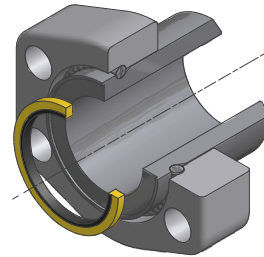

Size Inch	Tube	Complete Part Order code	Retaining Ring	Bonded Seal	Flange Order code	Weld Adapter Body Order code	D1	D2	L	Weight (Steel) kg/1 kit
1 1/2	38X5.0	R-624WA-38X5.0S	R24X	BS24SNX	R-624-CFX	WA24-38X5.0SX	56	28	75	1.48
1 1/2	48.3X2.8	R-624WA-48.3X2.8S	R24X	BS24SNX	R-624-CFX	WA24-48.3X2.8SX	56	39	70	1.14
1 1/2	48.3X3.7	R-624WA-48.3X3.7S	R24X	BS24SNX	R-624-CFX	WA24-48.3X3.7SX	56	39	70	1.18
1 1/2	48.3X5.1	R-624WA-48.3X5.1S	R24X	BS24SNX	R-624-CFX	WA24-48.3X5.1SX	56	38	70	1.24
1 1/2	48.3X7.1	R-624WA-48.3X7.1S	R24X	BS24SNX	R-624-CFX	WA24-48.3X7.1SX	56	34	70	1.36
1 1/2	48.3X10.2	R-624WA-48.3X10.2S	R24X	BS24SNX	R-624-CFX	WA24-48.3X10.2SX	56	30	70	1.32
1 1/2	50X3.0	R-624WA-50X3.0S	R24X	BS24SNX	R-624-CFX	WA24-50X3.0SX	56	39	70	1.13
1 1/2	50X5.0	R-624WA-50X5.0S	R24X	BS24SNX	R-624-CFX	WA24-50X5.0SX	56	40	70	1.20
1 1/2	50X6.0	R-624WA-50X6.0S	R24X	BS24SNX	R-624-CFX	WA24-50X6.0SX	56	38	70	1.26
1 1/2	50x9.0	R-624WA-50X9.0S	R24X	BS24SNX	R-624-CFX	WA24-50X9.0SX	56	32	70	1.42
1 1/2	56X8.5	R-624WA-56X8.5S	R24X	BS24SNX	R-624-CFX	WA24-56X8.5SX	56	39	60	1.18
2	48.3X5.6	R-632WA-48.3X5.6S	R32X	BS32SNX	R-632-CFX	WA32-48.3X5.6SX	66	37	90	2.40
2	50X9.0	R-632WA-50X9.0S	R32X	BS32SNX	R-632-CFX	WA32-50X9.0SX	66	32	90	2.61
2	60X3.0	R-632WA-60X3.0S	R32X	BS32SNX	R-632-CFX	WA32-60X3.0SX	66	49	90	1.89
2	60X5.0	R-632WA-60X5.0S	R32X	BS32SNX	R-632-CFX	WA32-60X5.0SX	66	50	90	1.99
2	60X6.0	R-632WA-60X6.0S	R32X	BS32SNX	R-632-CFX	WA32-60X6.0SX	66	48	90	2.10
2	60X8.0	R-632WA-60X8.0S	R32X	BS32SNX	R-632-CFX	WA32-60X8.0SX	66	44	90	2.28
2	60x10.0	R-632WA-60X10.0S	R32X	BS32SNX	R-632-CFX	WA32-60X10.0SX	66	40	90	2.46
2	60.3X2.8	R-632WA-60.3X2.8S	R32X	BS32SNX	R-632-CFX	WA32-60.3X2.8SX	66	49	90	1.87
2	60.3X3.9	R-632WA-60.3X3.9S	R32X	BS32SNX	R-632-CFX	WA32-60.3X3.9SX	66	49	90	1.95
2	60.3X5.5	R-632WA-60.3X5.5S	R32X	BS32SNX	R-632-CFX	WA32-60.3X5.5SX	66	49	90	2.04
2	60.3X8.7	R-632WA-60.3X8.7S	R32X	BS32SNX	R-632-CFX	WA32-60.3X8.7SX	66	43	90	2.34
2	60.3X11.1	R-632WA-60.3X11.1S	R32X	BS32SNX	R-632-CFX	WA32-60.3X11.1SX	66	38	90	2.54
2	66X8.5	R-632WA-66X8.5S	R32X	BS32SNX	R-632-CFX	WA32-66X8.5SX	66	49	75	1.95
2 1/2	65X8.5	R-640WA-65X8.5S	R40X	BS40SNX	R-640-CFX	WA40-65X8.5SX	80	49	105	8.20
2 1/2	73X7.0	R-640WA-73X7.0S	R40X	BS40SNX	R-640-CFX	WA40-73X7.0SX	80	59	105	7.69
2 1/2	75X3.0	R-640WA-75X3.0S	R40X	BS40SNX	R-640-CFX	WA40-75X3.0SX	80	60	105	7.30
2 1/2	75X5.0	R-640WA-75X5.0S	R40X	BS40SNX	R-640-CFX	WA40-75X5.0SX	80	60	105	7.47
2 1/2	76.1X6.3	R-640WA-76.1X6.3S	R40X	BS40SNX	R-640-CFX	WA40-76.1X6.3SX	80	60	105	7.55
2 1/2	76.1X12.5	R-640WA-76.1X12.5S	R40X	BS40SNX	R-640-CFX	WA40-76.1X12.5SX	80	51	105	8.27
2 1/2	80X10.0	R-640WA-80X10.0S	R40X	BS40SNX	R-640-CFX	WA40-80X10.0SX	80	60	90	7.50
3	76.1X12.5	R-648WA-76.1X12.5S	R48X	BS48SNX	R-648-CFX	WA48-76.1X12.5SX	97	51	120	11.58
3	80X10.0	R-648WA-80X10.0S	R48X	BS48SNX	R-648-CFX	WA48-80X10.0SX	97	60	120	11.47
3	88.9X3.1	R-648WA-88.9X3.1S	R48X	BS48SNX	R-648-CFX	WA48-88.9X3.1SX	97	73	120	10.58
3	88.9X5.5	R-648WA-88.9X5.5S	R48X	BS48SNX	R-648-CFX	WA48-88.9X5.5SX	97	73	120	10.87
3	88.9X7.7	R-648WA-88.9X7.7S	R48X	BS48SNX	R-648-CFX	WA48-88.9X7.7SX	97	74	120	11.07
3	88.9X8.8	R-648WA-88.9X8.8S	R48X	BS48SNX	R-648-CFX	WA48-88.9X8.8SX	97	71	120	11.30
3	88.9X11.1	R-648WA-88.9X11.1S	R48X	BS48SNX	R-648-CFX	WA48-88.9X11.1SX	97	67	120	11.74
3	88.9X12.5	R-648WA-88.9X12.5S	R48X	BS48SNX	R-648-CFX	WA48-88.9X12.5SX	97	64	120	12.00
3	88.9X15.2	R-648WA-88.9X15.2S	R48X	BS48SNX	R-648-CFX	WA48-88.9X15.2SX	97	59	120	12.40
3	90X3.5	R-648WA-90X3.5S	R48X	BS48SNX	R-648-CFX	WA48-90X3.5SX	97	73	120	10.59
3	90X5.0	R-648WA-90X5.0S	R48X	BS48SNX	R-648-CFX	WA48-90X5.0SX	97	80	120	10.90
3	90X9.0	R-648WA-90X9.0S	R48X	BS48SNX	R-648-CFX	WA48-90X9.0SX	97	72	120	11.25
3	97X12.0	R-648WA-97X12.0S	R48X	BS48SNX	R-648-CFX	WA48-97X12.0SX	97	73	110	11.05

Other sizes on request.

Please change suffixes according to material/surface required

Order code suffixes		
Material	Suffix surface and material	Example
Steel	S	R-620WA-46X8.0S
Stainless steel	SS	R-620WA-46X8.0SS



BF – Bulkhead flange

SAE 6000/ISO 6162-2

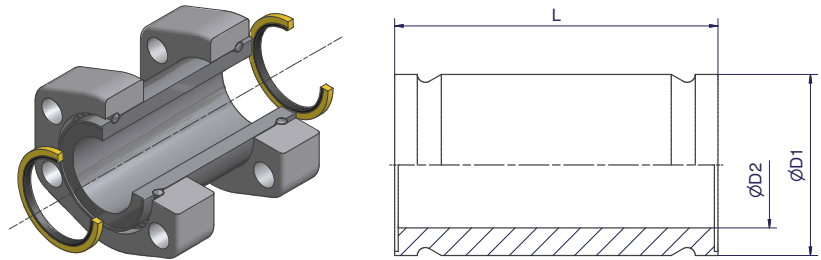

Size Inch	Complete Part Order code	Bulkhead Body Order code	D1	D2	L	Weight body (Steel) kg/1 piece
1/2	R-608BFS	BF08SX	26	14	170	0.49
3/4	R-612BFS	BF12SX	36	20	170	0.92
1	R-616BFS	BF16SX	39	24	170	0.96
1 1/4	R-620BFS	BF20SX	46	30	180	1.30
1 1/2	R-624BFS	BF24SX	56	39	180	1.75
2	R-632BFS	BF32SX	66	49	210	2.45
2 1/2	R-640BFS	BF40SX	80	60	220	3.70
3	R-648BFS	BF48SX	97	73	240	7.85

Other sizes on request.

Please change suffixes according to material/surface required

Order code suffixes		
Material	Suffix surface and material	Example
Steel	S	R-620BFS
Stainless steel	SS	R-620BFSS

RF – Reducer flange

SAE 6000/ISO 6162-2

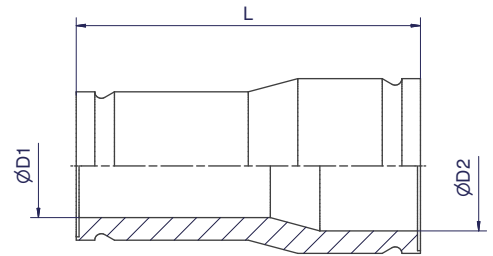
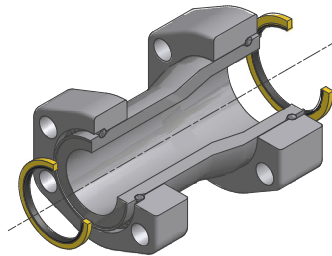

Size Inch	Complete Part Order code	Reducer Body Order code	D1	D2	L	Weight body (Steel) kg/1 piece
3/4 - 1/2	R-612-608RFCF	RF12-08CFX	14	20	65	0.3
1 - 1/2	R-616-608RFCF	RF16-08CFX	14	24	100	0.4
1 - 3/4	R-616-612RFCF	RF16-12CFX	20	24	100	0.6
1 1/4 - 1	R-620-616RFCF	RF20-16CFX	24	30	110	0.7
1 1/2 - 1	R-624-616RFCF	RF24-16CFX	24	39	115	0.9
1 1/2 - 1 1/4	R-624-620RFCF	RF24-20CFX	30	39	130	1.1
2 - 1 1/4	R-632-620RFCF	RF32-20CFX	30	49	130	1.3
2 - 1 1/2	R-632-624RFCF	RF32-24CFX	39	49	130	1.4
2 1/2 - 1 1/2	R-640-624RFCF	RF40-24CFX	39	60	150	2.1
2 1/2 - 2	R-640-632RFCF	RF40-32CFX	49	60	150	2.2
3 - 2	R-648-632RFCF	RF48-32CFX	49	73	180	3.4
3 - 2 1/2	R-648-640RFCF	RF48-40CFX	60	73	180	3.7

Other sizes on request.

Please change suffixes according to material/surface required

Order code suffixes		
Material	Suffix surface and material	Example
Steel, zinc plated, Cr(VI)-free	CF	R-620-616RFCF
Stainless steel	SS	R-620-616RFSS



FB90 – 90° Flange bend

SAE 6000/ISO 6162-2

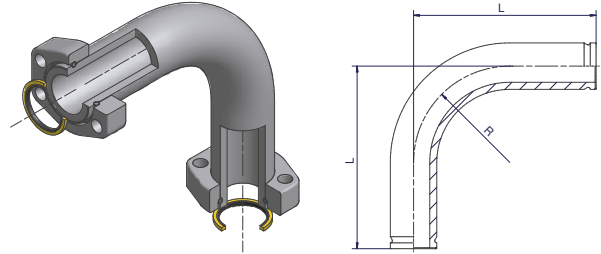

Size Inch	Tube	Complete Part Order code	90° Flange Bend Order code	L	R	Weight body (Steel) kg/1 piece
1 1/4	46X8.0	R-620FB90S	FB90-20SX*	180	96	2.35
1 1/2	56X8.5	R-624FB90CF	FB90-24CFX	220	116	3.84
2	66X8.5	R-632FB90CF	FB90-32CFX	275	165	5.72
2 1/2	80X10.0	R-640FB90S*	FB90-40SX*	370	200	11.20
3	97X12.0	R-648FB90S*	FB90-48SX*	450	243	19.90

*only available as Steel version.

Please change suffixes according to material/surface required

Order code suffixes			
Tube material	Suffix surface and material	Example	Comments
Steel, zinc plated, Cr(VI)-free	CF	R-624FB90CF	
Steel, black phosphated	SX	R-620FB90S	
Stainless steel	SS	R-620FB90SS	on request

FB45 – 45° Flange bend

SAE 6000/ISO 6162-2

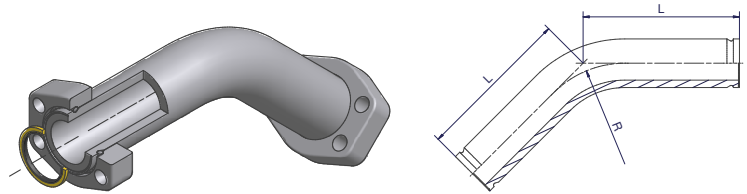

Size Inch	Tube	Complete Part Order code	45° Flange Bend Order code	L	R	Weight body (Steel) kg/1 piece
1 1/4	46X8.0	R-620FB45S	FB45-20SX*	150	96	2.18
1 1/2	56X8.5	R-624FB45CF	FB90-45CFX	180	116	3.49
2	66X8.5	R-632FB45CF	FB90-45CFX	220	165	5.16
2 1/2	80X10.0	R-640FB45S*	FB45-40SX*	240	200	8.07
3	97X12.0	R-648FB45S*	FB45-48SX*	260	243	12.70

Other sizes on request.
*only available as Steel version.

Please change suffixes according to material/surface required

Order code suffixes			
Tube material	Suffix surface and material	Example	Comments
Steel, zinc plated, Cr(VI)-free	CF	R-624FB45CF	
Steel, black phosphated	S	R-620FB45S	
Stainless steel	SS	R-620FB45SS	on request



FB90 – 90° Flange bend

SAE 6000/ISO 6162-2

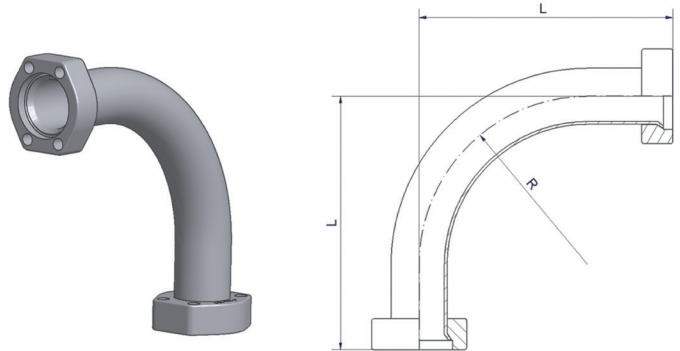

Size Inch	Tube	Complete Part Order code	L	R
1 1/2	50X5.0	F37-624FB90	220	150
2	60X5.0	F37-632FB90	275	180

Other sizes on request.

Please change suffixes according to material/surface required

Order code suffixes		
Material	Suffix surface and material	Example
Steel, zinc plated, Cr(VI)-free	CF	F37-624FB90CF
Stainless steel	SS	F37-624FB90SS

FB45 – 45° Flange bend

SAE 6000/ISO 6162-2

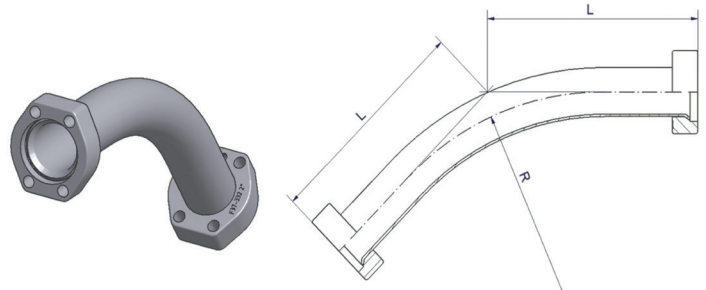

Size Inch	Tube	Complete Part Order code	L	R
1 1/2	50X5.0	F37-624FB45	180	150
2	60X5.0	F37-632FB45	220	180

Other sizes on request.

Please change suffixes according to material/surface required

Order code suffixes		
Material	Suffix surface and material	Example
Steel, zinc plated, Cr(VI)-free	CF	F37-624FB45CF
Stainless steel	SS	F37-624FB45SS



LF – Elbow flange

SAE 6000/ISO 6162-2

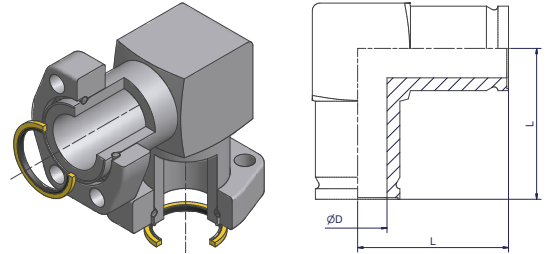

Size Inch	Complete Part Order code	Elbow Flange body Order code	D	L	Weight body (Steel) kg/1 piece
1/2	R-608LFCF	LF08CFX	14	70	0.50
3/4	R-612LFCF	LF12CFX	20	80	1.07
1	R-616LFCF	LF16CFX	24	85	1.32
1 1/4	R-620LFCF	LF20CFX	30	90	1.72
1 1/2	R-624LFCF	LF24CFX	39	100	2.60
2	R-632LFCF	LF32CFX	49	110	4.02
2 1/2	R-640LFCF	LF40CFX	60	130	6.40
3	R-648LFCF	LF48CFX	73	160	10.80

Other sizes on request.

Please change suffixes according to material/surface required

Order code suffixes		
Material	Suffix surface and material	Example
Steel, zinc plated, Cr(VI)-free	CF	R-620LFCF
Stainless steel	SS	R-620LFSS

TF – TEE flange

SAE 6000/ISO 6162-2

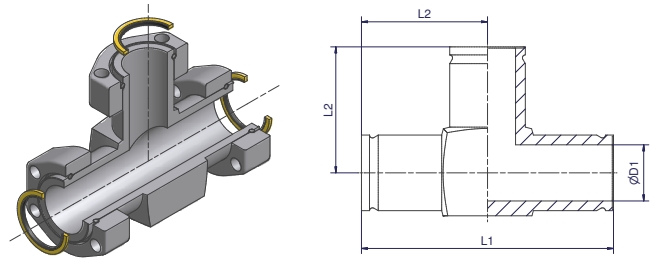

Size Inch	Complete Part Order code	Tee Flange body Order code	D1	L1	L2	Weight body (Steel) kg/1 piece
1/2	R-608TCF	TF08CFX	14	120	60	0.75
3/4	R-612TCF	TF12CFX	20	130	65	3.20
1	R-616TCF	TF16CFX	24	140	70	2.00
1 1/4	R-620TCF	TF20CFX	30	180	90	2.03
1 1/2	R-624TCF	TF24CFX	39	200	100	3.13
2	R-632TCF	TF32CFX	49	220	110	4.53
2 1/2	R-640TCF	TF40CFX	60	260	130	7.05
3	R-648TCF	TF48CFX	73	320	160	12.81

Other sizes on request.

Please change suffixes according to material/surface required

Order code suffixes		
Material	Suffix surface and material	Example
Steel, zinc plated, Cr(VI)-free	CF	R-620TCF
Stainless steel	SS	R-620TFSS



LB – Flange L-block

SAE 6000/ISO 6162-2

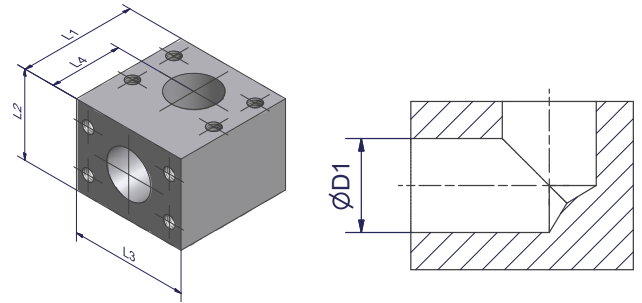

Size Inch	Order code	D1	L1	L2	L3	L4	Weight (Steel) kg/1 piece
1/2	LB608CFX	13	61	46	61	38	1.3
3/4	LB612CFX	19	75	60	75	49	2.4
1	LB616CFX	25	80	65	80	54	2.8
1 1/4	LB620CFX	30	86	64	90	57	3.2
1 1/2	LB624CFX	38	100	74	100	66	4.6
2	LB632CFX	48	122	88	132	78	8.8

Other sizes and custom versions on request.

Please change suffixes according to material/surface required

Order code suffixes		
Material	Suffix surface and material	Example
Steel, zinc plated, Cr(VI)-free	CF	LB620CFX
Stainless steel	SS	LB620SSX

LBR – Flange L-block reducer

SAE 6000/ISO 6162-2

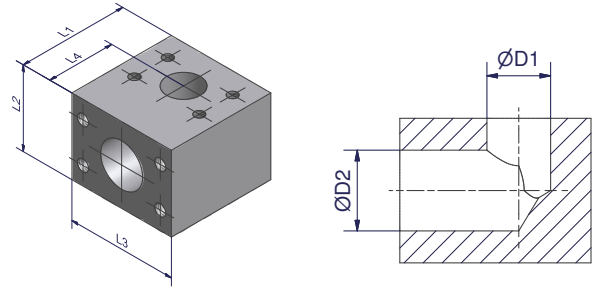

Size Inch	Order code	D1	D2	L1	L2	L3	L4	Weight (Steel) kg/1 piece
1 - 3/4	LBR616-612CFX	19	25	80	65	80	54	2.6
1 1/4 - 3/4	LBR620-612CFX	19	30	86	64	90	57	3.0
1 1/4 - 1	LBR620-616CFX	25	30	86	64	90	57	3.3
1 1/2 - 1	LBR624-616CFX	25	38	100	74	100	66	4.9
1 1/2 - 1 1/4	LBR624-620CFX	30	38	100	74	100	66	4.8
2 - 1	LBR632-616CFX	25	48	122	88	132	78	9.4
2 - 1 1/4	LBR632-620CFX	30	48	122	88	132	78	9.3
2 - 1 1/2	LBR632-624CFX	38	48	122	88	132	78	9.1

Other sizes and custom versions on request.

Please change suffixes according to material/surface required

Order code suffixes		
Material	Suffix surface and material	Example
Steel, zinc plated, Cr(VI)-free	CF	LBR620-616CFX
Stainless steel	SS	LBR620-616SSX



TB – Flange T-block

SAE 6000/ISO 6162-2

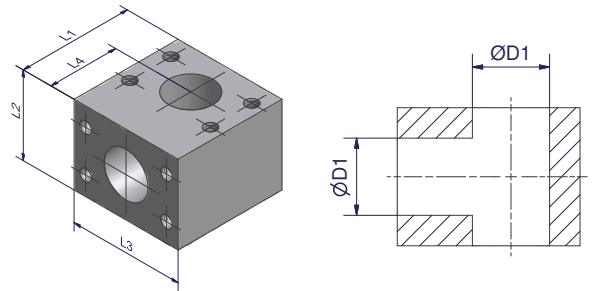

Size Inch	Order code	D1	L1	L2	L3	L4	Weight (Steel) kg/1 piece
1/2	TB608CFX	13	61	46	61	38	1.10
3/4	TB612CFX	19	75	60	75	49	2.27
1	TB616CFX	25	80	65	80	54	2.46
1 1/4	TB620CFX	30	86	64	90	57	3.04
1 1/2	TB624CFX	38	100	74	100	66	4.40
2	TB632CFX	50	122	88	132	78	8.07

Other sizes and custom versions on request.

Please change suffixes according to material/surface required

Order code suffixes		
Material	Suffix surface and material	Example
Steel, zinc plated, Cr(VI)-free	CF	TB620CFX
Stainless steel	SS	TB620SSX

TBR – Flange T-block reducer

SAE 6000/ISO 6162-2

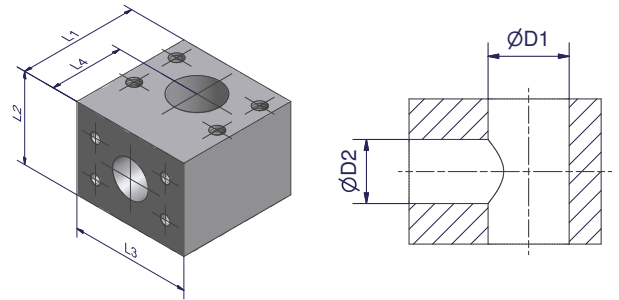

Size Inch	Order code	D1	D2	L1	L2	L3	L4	Weight (Steel) kg/1 piece
1 - 3/4 - 1	TBR616-612-616CFX	25	19	80	65	80	54	2.7
1 1/4 - 1 - 1 1/4	TBR620-616-620CFX	30	25	86	64	90	57	3.1
1 1/2 - 1 - 1 1/2	TBR624-616-624CFX	38	25	100	74	100	66	4.6
1 1/2 - 1 1/4 - 1 1/2	TBR624-620-624CFX	38	30	100	74	100	66	4.4
2 - 1 1/4 - 2	TBR632-620-632CFX	48	30	122	88	132	78	8.7
2 - 1 1/2 - 2	TBR632-624-632CFX	48	38	122	88	132	78	8.5

Other sizes and custom versions on request.

Please change suffixes according to material/surface required

Order code suffixes		
Material	Suffix surface and material	Example
Steel, zinc plated, Cr(VI)-free	CF	TBR620-616-620CFX
Stainless steel	SS	TBR620-616-620SSX



BFV – Blind flange

SAE 6000/ISO 6162-2

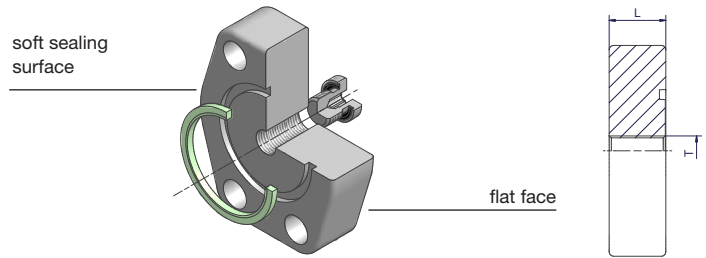

Size Inch	Flange incl. VSTI-ED and Seal Order code	L	T1	Weight body (Steel) kg/1 piece
1/2	F37-608BFVCF	20	G 1/4	0.29
3/4	F37-612BFVCF	24	G 1/4	0.57
1	F37-616BFVCF	24	G 1/4	0.76
1 1/4	F37-620BFVCF	30	G 1/4	1.27
1 1/4	F37-620H12BFVCF	30	G 1/4	1.31
1 1/2	F37-624BFVCF	35	G 1/4	2.16
2	F37-632BFVCF	40	G 1/4	3.40
2 1/2	F37-640BFVCF	50	G 1/4	7.74
3	F37-648BFVCF	52	G 1/4	11.65

Please change suffixes according to material/surface required

Order code suffixes		
Material	Suffix surface and material	Example
Steel, zinc plated, Cr(VI)-free	CF	F37-620BFVCF
Stainless steel	SS	F37-620BFVSS

BS – Bonded seal

SAE 6000/ISO 6162-2

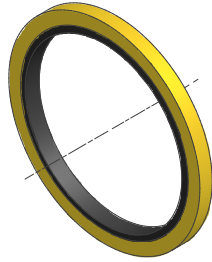

Size Inch	Steel	Stainless Steel
1/2	BS08SNX	BS08SSNX
3/4	BS12SNX	BS12SSNX
1	BS16SNX	BS16SSNX
1 1/4	BS20SNX	BS20SSNX
1 1/2	BS24SNX	BS24SSNX
2	BS32SNX	BS32SSNX
2 1/2	BS40SNX	BS40SSNX
3	BS48SNX	BS48SSNX

Sealing: NBR
Other sealing materials like FKM on request.

F37S/F37RS – F37 Seal

SAE 6000/ISO 6162-2

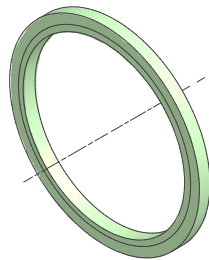

Size Inch	F37 Seal (F37 seal for flaring system)	F37RS (F37 seal for retaining ring system)
1/2	F37S08X	-
3/4	F37S12X	-
1	F37S16X	-
1 1/4	F37S20X	F37RS20X
1 1/2	F37S24X	F37RS24X
2	F37S32X	F37RS32X
2 1/2	F37S40X	F37RS40X
3	F37S48X	F37RS48X

Other sizes on request
Sealing: Polyurethane
Material properties and applications see page 20.



AO – Adapter bonded seal to F37 seal/O-Ring

SAE 6000/ISO 6162-2

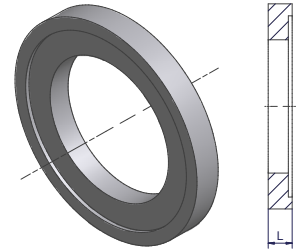

Size Inch	Adapter* Order code	L	Weight (Steel) kg/1 piece
1/2	AO08CFX	5	0.02
3/4	AO12CFX	5	0.02
1	AO16CFX	7	0.06
1 1/4	AO20CFX	7	0.06
1 1/2	AO24CFX	7	0.08
2	AO32CFX	7	0.10

*Part excluding seals.
Other sizes on request.
For assembling add L to the corresponding bolt length.

Please change suffixes according to material/surface required

Order code suffixes		
Material	Suffix surface and material	Example
Steel, zinc plated, Cr(VI)-free	CF	AO32CFX
Stainless steel	SS	AO32SSX

TBT – Tee between bonded seal

SAE 6000/ISO 6162-2

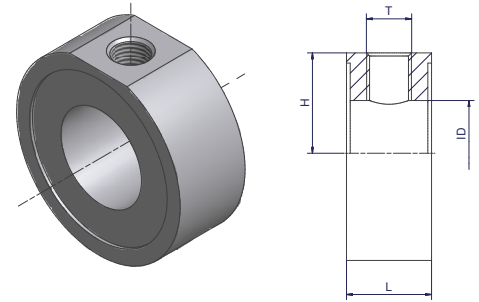

Size Inch	Order code*	L	H	T	ID	Weight (Steel) kg/1 piece
1	TBT16-1/4CFX	25	20.5	G 1/4	25	0.21
1 1/4	TBT20-1/4CFX	25	24.5	G 1/4	27	0.30
1 1/4	TBT20-1/2CFX	40	22.5	G 1/2	24	0.49
1 1/2	TBT24-1/4CFX	25	29.5	G 1/4	31	0.42
1 1/2	TBT24-1/2CFX	40	28.0	G 1/2	30	0.68
2	TBT32-1/4CFX	25	35.0	G 1/4	41	0.51
2	TBT32-1/2CFX	40	34.0	G 1/2	38	0.87
2 1/2	TBT40-1/4CFX	30	41.5	G 1/4	60	0.63
3	TBT48-1/4CFX	30	50.0	G 1/4	72	0.90

*Part excluding seals.
 For assembling add L to the corresponding bolt length.
 For testpoints and diagnostic test equipment see catalogue 4100, Industrial Tube Fittings Europe.

Alternative versions on request.

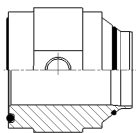

TFVB

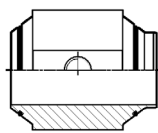

TTB

Please change suffixes according to material/surface required

Order code suffixes		
Material	Suffix surface and material	Example
Steel, zinc plated, Cr(VI)-free	CF	TBT24-1/4CFX
Stainless steel	SS	TBT24-1/4SSX



AP – SAE flange locking plate

SAE 6000/ISO 6162-2

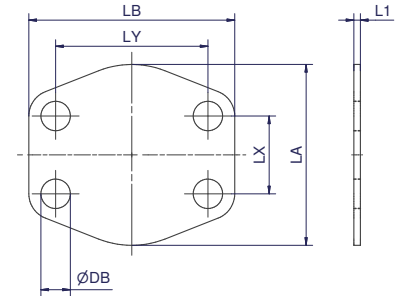

Nom. flange size		Order code	L1	LA	LB	LX	LY	DB	Weight body (Steel) kg/1 piece
SAE (In)	ISO (DN)								
1/2	13	8AP2	4	47	57	18.2	40.5	9.0	0.02
3/4	19	12AP2	4	53	71	23.8	50.8	11.0	0.02
1	25	16AP2	4	66	80	27.8	57.1	13.0	0.03
1 1/4	32	20AP2	4	77	94	31.8	66.7	15.0	0.04
1 1/2	38	24AP2	4	89	103	36.5	79.4	17.0	0.05
2	51	32AP2	4	123	135	44.5	96.8	21.0	0.06
2 1/2	64	40AP2	4	150	166	58.7	123.8	25.0	0.08
3	76	48AP2	4	178	210	71.4	152.4	32.0	0.10

This flange locking plate is not to be used under pressure!

Please change suffixes according to material/surface required

Order code suffixes			
Material	Suffix surface and material	Example	Description
Steel, zinc plated, Cr(VI)-free	CF	8AP2CF	only locking plate
Stainless steel	SS	8AP2SS	only locking plate
Steel (zinc plated, Cr(VI)-free), SBR 70 Shore A	CFSBR70	8AP2CFSBR70	locking incl. rubber plate L1 increase due to rubber plate

Bolts and nuts for flange

SAE 6000/ISO 6162-2



F37 Flare Flange

Size Inch	Flange	F37 Seal/Flat Face/Bonded Seal		Nut
		Recommended bolts Tube to Port	Recommended bolts Tube to Tube	
1/2	F37-608-CFX	4 x ZYLS8X35	4 x ZYLS8X65	4 x ISO4032-M8
3/4	F37-612-CFX	4 x ZYLS10X45	4 x ZYLS10X75	4 x ISO4032-M10
1	F37-616-CFX	4 x ZYLS12X45	4 x ZYLS12X75	4 x ISO4032-M12
1 1/4	F37-620-CFX	4 x ZYLS14X55	4 x ZYLS14X90	4 x ISO4032-M14
1 1/4	F37-620H12-CFX	4 x ZYLS12X55	4 x ZYLS12X90	4 x ISO4032-M12
1 1/2	F37-624-CFX	4 x ZYLS16X60	4 x ZYLS16X100	4 x ISO4032-M16
2	F37-632-CFX	4 x ZYLS20X70	4 x ZYLS20X120	4 x ISO4032-M20

Retaining Ring Flange

Size Inch	Flange	Flat Face/Bonded Seal		Pipe Seal Carrier (PSC)		Nut
		Recommended bolts Tube to Port	Recommended bolts Tube to Tube	Recommended bolts Tube to Port	Recommended bolts Tube to Tube	
1/2	R-608-CFX	4 x ZYLS8X35	4 x ZYLS8X60	-	-	4 x ISO4032-M8
3/4	R-612-CFX	4 x ZYLS10X45	4 x ZYLS10X70	-	-	4 x ISO4032-M10
1	R-616-CFX	4 x ZYLS12X45	4 x ZYLS12X80	-	-	4 x ISO4032-M12
1 1/4	R-620-CFX	4 x ZYLS14X55	4 x ZYLS14X90	4 x ZYLS14X60	4 x ZYLS14X100	4 x ISO4032-M14
1 1/4	R-620H12-CFX	4 x ZYLS12X55	4 x ZYLS12X90	4 x ZYLS12X60	4 x ZYLS12X100	4 x ISO4032-M12
1 1/2	R-624-CFX	4 x ZYLS16X60	4 x ZYLS16X100	4 x ZYLS16X70	4 x ZYLS16X110	4 x ISO4032-M16
2	R-632-CFX	4 x ZYLS20X70	4 x ZYLS20X120	4 x ZYLS20X80	4 x ZYLS20X130	4 x ISO4032-M20
2 1/2	R-640-CFX	4 x ZYLS24X90	4 x ZYLS24X150	4 x ZYLS24X110	4 x ZYLS24X160	4 x ISO4032-M24
3	R-648-CFX	4 x ZYLS30X100	4 x ZYLS30X160	4 x ZYLS30X120	4 x ZYLS30X170	4 x ISO4032-M30

Bolts and nuts are not included in complete part numbers.

Latest information about nuts and bolts see www.parker.com/hpce -> Resources -> Installation Guides & Manuals

Please add the suffixes according to the bolt quality

	Steel		0Stainless Steel
	8.8 zinc plated (VZX)	10.9 zinc flaked (ZNFLX)	A4-80X
Bolt	ZYLS16X60VZX	ZYLS16X60109ZNFLX	ZYLS16X60A4-80X
Nut	ISO4032-M12-8VZX	ISO4032-M12-10ZNFLX	ISO4032-M12-80X

* Bolt grade 10.9 recommended.
Bolt grade 8.8 can affect the pressure capability.



KH – Ball valve drilled and tapped for SAE 6000 and SAE 3000 flanges

SAE 6000/ISO 6162-2

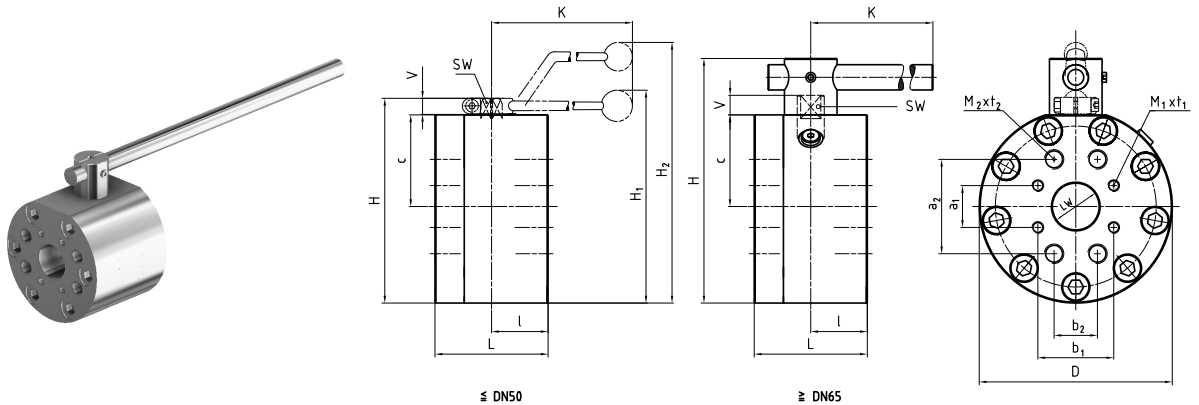

Material Steel

Size Inch	Order Code	DN	LW	L	I	D	H	c	V	K	SW	SAE 3000 boring pattern				SAE 6000 boring pattern				H1	H2	Material Code	Lever	Weight kg	W.P. bar
												a1	b1	M1	t1	a2	b2	M2	t2						
1/2	KH08-15CF	15	15	75	35	88	88	31.0	13	170	12	17.5	38.1	M08	18	40.5	18.2	M08	18	-	132	212A	St	2.96	350 / 420
3/4	KH12-20CF	20	20	80	35	98	100	36.5	14	170	14	22.2	47.6	M10	18	50.8	23.8	M10	18	-	150	212A	St	4.20	350 / 420
1	KH16-25CF	25	25	88	38	118	113	39.5	14	170	14	26.2	52.4	M10	20	57.2	27.8	M10	20	-	163	212A	St	6.00	320 / 420
1 1/4	KH20-32CF*	32	32	100	50	145	158	68.0	17	306	17	30.2	58.7	M10	20	66.7	31.8	M12	22	-	232	212A	St	11.70	280 / 420
1 1/4	KH20-32TM1214CF*	32	32	100	50	145	158	68.0	17	306	17	30.2	58.7	M12	20	66.7	31.8	M14	22	-	232	212A	St	11.65	210 / 400
1 1/2	KH24-38CF	40	38	110	55	165	178	78.0	17	306	17	35.7	69.9	M12	20	79.4	36.5	M16	27	-	252	212A	St	17.10	210 / 420
2	KH32-48CF	50	48	116	58	198	210	94.0	17	306	17	42.9	77.8	M12	20	96.8	44.5	M20	28	-	284-	212A	St	24.60	210 / 420
2 1/2	KH40-63CF	65	63	170	75	218	275	100.0	20	600	16	88.9	50.8	M12	19	58.7	123.8	M24	41	-	-	282A	St	44.40	175 / 420
3	KH48-76CF	80	76	170	79	258	315	115.0	26	600	19	106.4	61.9	M16	24	71.4	152.4	M30	47	-	-	282A	St	54.90	160 / 420

*Please choose between KH20-32CF and KH20-32TM1214CF according to needed connection threads M1 and M2.
Steel ball valves 1/2" up to 2" with SAE 3000 and SAE 6000 boring pattern.
The bore pattern for 2 1/2" and 3" is turned to 90°.

Please change suffixes according to material/surface required

Order code suffixes			
Material	Suffix surface and material	Example	Comments
Steel, zinc plated, Cr(VI)-free	CF	KH20-32CF	

	Material 221A	Material 282A
Body	Stahl	Steel
Ball	Stahl	Steel
Stem	Stahl	Stainless Steel
Ball seats	POM	POM
O-Ring	NBR	NBR
Tmin / Tmax	-10°C / 100°C	-10°C / 100°C

KH – Ball valve drilled and tapped for SAE 6000 flanges

SAE 6000/ISO 6162-2

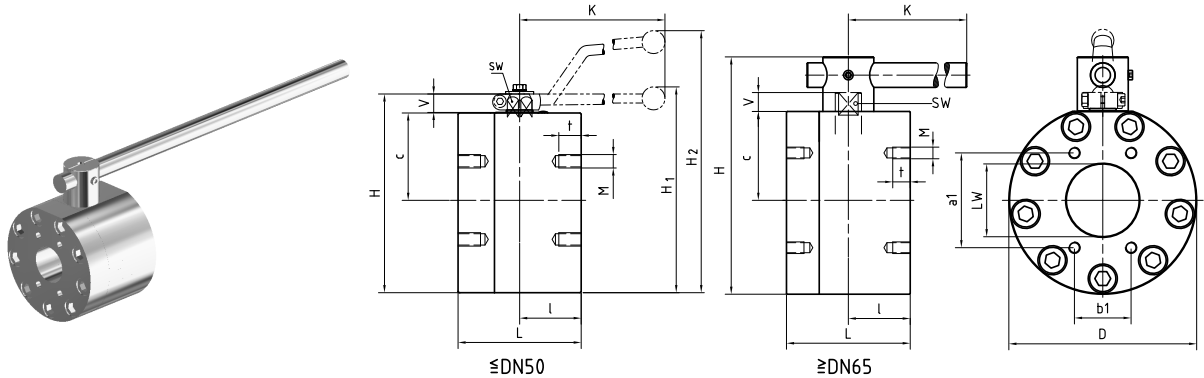

Material Stainless Steel

Size Inch	Order Code	DN	LW	L	I	D	H	c	V	K	SW	a1	b1	M	t	H1	H2	Material Code	Lever	Weight kg	W.P. (bar)
1/2	KH608-15SS	15	15	75	35	78	88	31.0	13	160	12	40.5	18.2	M08	18	-	127	442A	Al	2.50	420
3/4	KH612-20SS	20	20	80	35	98	100	36.5	14	200	14	50.8	23.8	M10	18	103	-	442A	Zn	4.25	420
1	KH616-25SS	25	25	88	38	118	113	39.5	14	200	14	57.2	27.8	M12	20	116	-	442A	Zn	6.30	420
1 1/4	KH620-32SS*	32	32	100	50	145	158	68.0	17	320	17	66.7	31.8	M12	22	167	-	442A	Al	11.80	420
1 1/4	KH620-32TM14SS*	32	32	100	50	145	158	68.0	17	320	17	66.7	31.8	M14	22	167	-	442A	Al	11.80	400
1 1/2	KH624-38SS	40	38	110	55	165	178	78.0	17	320	17	79.4	36.5	M16	27	187	-	442A	Al	16.90	420
2	KH632-48SS	50	48	116	58	198	210	94.0	17	320	17	96.8	44.5	M20	28	219	-	442A	Al	24.60	420
2 1/2	KH640-63SS	65	63	170	75	218	275	100.0	20	600	16	58.7	123.8	M24	41	-	-	442A	St	44.50	420
3	KH648-76SS	80	76	170	79	258	315	114.5	26	600	19	71.4	152.4	M30	47	-	-	442A	St	63.50	420

*Please choose between KH620-32SS and KH620-32TM14SS according to needed connection threads M.

Please change suffixes according to material/surface required

Order code suffixes			
Material	Suffix surface and material	Example	Comments
Stainless steel	SS	KH620-32SS	

	Material 442A
Body	Stainless Steel
Ball	Stainless Steel
Stem	Stainless Steel
Ball seats	POM
O-Ring	NBR
Tmin / Tmax	-30°C / 100°C



KH-R – Ball valve with SAE 6000 Flanges

SAE 6000/ISO 6162-2

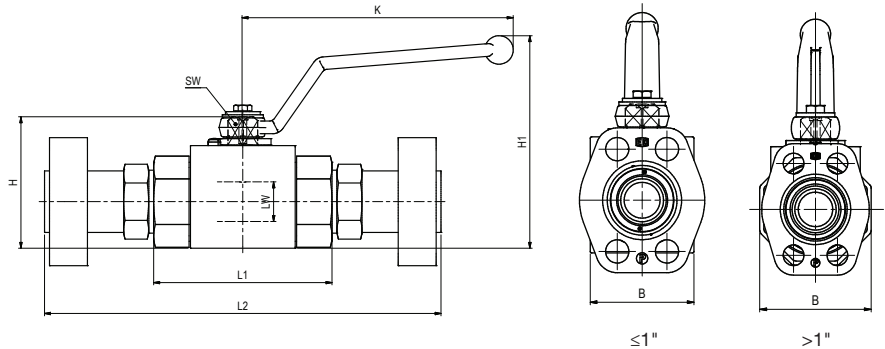
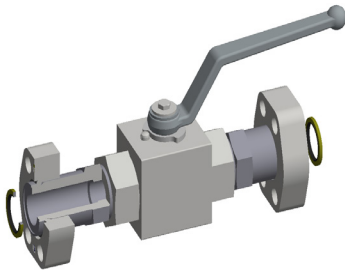

Material Steel

Size Inch	Complete part Order code	Valve body Order code	LW	L1	L2	B	H	SW	K	H1	Weight (Steel) kg/1 kit	W.P. bar
3/4	KH-R-612-20CF	KH-R-12-20CF	20	95	217	49	75	14	171	126	2.8	420
1	KH-R-616-25CF	KH-R-16-25CF	25	113	251	58	83	14	171	134	4.2	350
1	KH-R-616-420BDN25CF	KH-R-16-420BDN25CF	25	113	251	70	88	14	170	140	5.1	420
1 1/4	KH-R-620-32CF	KH-R-20-32CF	32	111	271	81	107	17	306	178	6.8	420
1 1/2	KH-R-624-38CF	KH-R-24-38CF	38	130	316	100	124	17	306	196	10.8	420
2	KH-R-632-48CF	KH-R-32-48CF	48	140	348	118	138	17	306	210	16.5	420

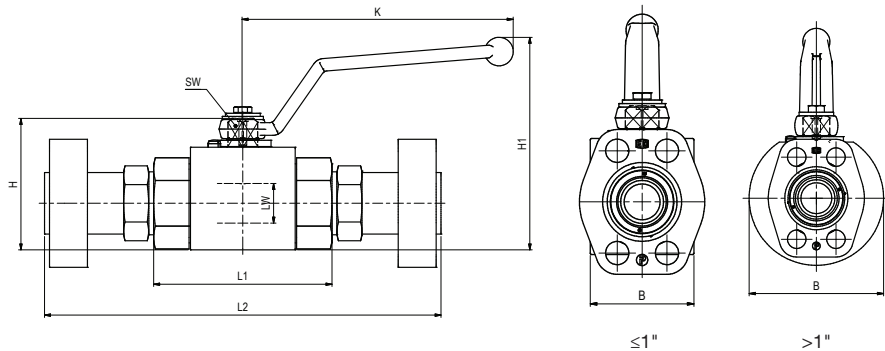
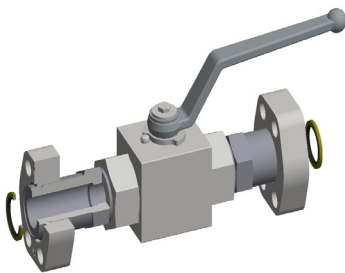

Material Stainless Steel

Size Inch	Complete part Order code	Valve body Order code	LW	L1	L2	B	H	SW	K	H1	Weight (Steel) kg/1 kit	W.P. bar
3/4	KH-R-612-20SS	KH-R-12-20SS	20	95	217	49	75	14	171	126	2.8	350
1	KH-R-616-25SS	KH-R-16-25SS	25	113	251	58	83	14	171	134	4.2	350
1	KH-R-616-420BDN25SS	KH-R-16-420BDN25SS	25	131	268	70	88	14	160	124	6.8	350
1 1/4	KH-R-620-32SS	KH-R-20-32SS	32	111	271	109	121	17	228	195	9.4	420
1 1/2	KH-R-624-38SS	KH-R-24-38SS	38	130	316	124	136	17	228	210	13.8	420
2	KH-R-632-48SS	KH-R-32-48SS	48	140	348	132	145	17	228	219	18.7	420

Other sizes on request.

Please change suffixes according to material/surface required

Order code suffixes		
Material	Suffix surface and material	Example
Steel, zinc plated, Cr(VI)-free	CF	KH-R-620-32CF
Stainless steel	SS	KH-R-620-32SS

	Material 112A	Material 442A
Body	Steel	Stainless Steel
Ball	Steel	Stainless Steel
Stem	Steel	Stainless Steel
Ball seats	POM	POM
O-Ring	NBR	NBR
Tmin / T max	-20°C / 100 °C	-30°C / 100°C

RHD-R – Non return valves

SAE 6000/ISO 6162-2

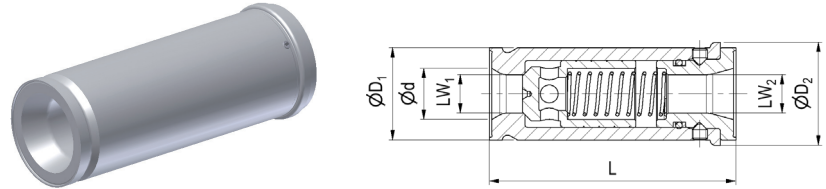

Material Steel

Size Inch	Complete part Order code	Valve body Order code	L	D1	D2	d	LW1	LW2	Weight body (Steel) kg/1 piece	W.P. bar
3/4	RHD-R-612-0.5BCF	RHD-R-12-0.5BCF	96.4	36	40.2	20.0	15	15.0	0.53	420
1	RHD-R-616-0.5BCF	RHD-R-16-0.5BCF	116.6	39	44.2	23.0	18	13.0	0.78	
1 1/4	RHD-R-620-0.5BCF	RHD-R-20-0.5BCF	135.6	46	51.1	30.0	20	17.0	1.26	
1 1/2	RHD-R-624-0.5BCF	RHD-R-24-0.5BCF	135.6	56	60.5	38.8	30	27.0	1.61	
2	RHD-R-632-0.5BCF	RHD-R-32-0.5BCF	180.1	66	70.5	49.0	40	36.4	2.54	

Opening pressure 0.5 bar.

Other pressure rates on request.

Complete Part = body + flanges + retaining rings + bonded seals.

Please change suffixes according to material/surface required

Order code suffixes		
Material	Suffix surface and material	Example
Steel, zinc plated, Cr(VI)-free	CF	RHD-R-620-0.5BCF
Stainless steel (inner parts steel)	SS	RHD-R-620-0.5BSS

	Materials
Body	Steel / Stainless Steel
Piston	Steel
O-Ring	NBR
Tmin / T max	-10°C / 100 °C









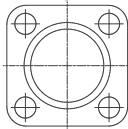
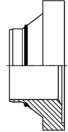
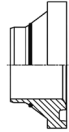
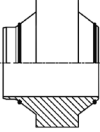
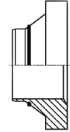

ISO 6164 System

250 – 400 bar

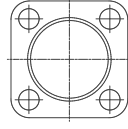
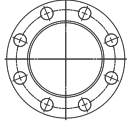
ENGINEERING YOUR SUCCESS.

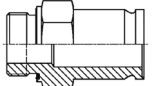
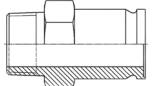
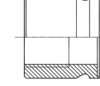
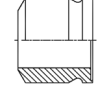
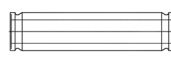
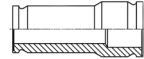
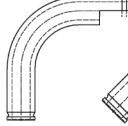
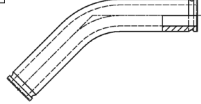
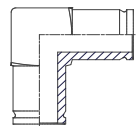
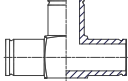
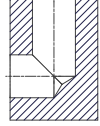
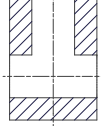
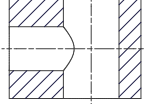
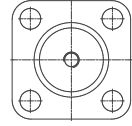
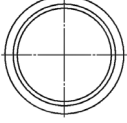
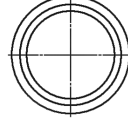
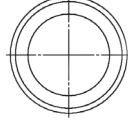
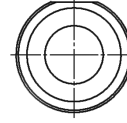
Programme overview ISO 6164 footprint

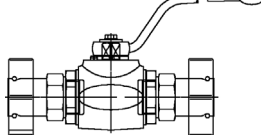
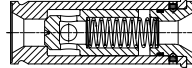
Parflange® F37 connection parts	Flanges  F37 – p.141/142							
	Inserts     TFB – p.145 TFV – p.146 TT – p.147 TF – p.148				Sleeve  SL – p.149			
Retaining ring connection parts	Flanges     R – p.143 R – p.143 R-Ring – p.150 PSC – p.144							
	Male / Female    MTF-R – p.151 MTF-N – p.152 FTF-R – p.153			Weld  WA – p.154				
	Tube to Tube       BF – p.155 RF – p.156 FB90 – p.157 FB45 – p.158 LF – p.159 TF – p.160							
SAE connection parts	Blocks     LB – p.161 TB – p.162 TBR – p.163 BFV – p.164							
Seals Adapter Bolts	Components     BS – p.165 F37S – p.165 AO – p.166 TBT – p.167				Bolts and Nuts  p.168			
Ball valves	   KH – p.169/170 KH-R – p.171 RHD-R – p.172							

F37 - Flare flange | ISO 6164 footprint

ISO 6164

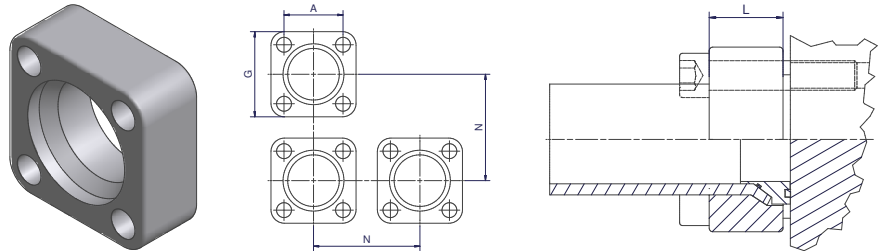

Parflange F37 flange dimensions

Size Inch	Flange Order code	A	G	N	L	Weight (Steel) kg/1 piece	W.P. bar
2	F37-432-CFX	69.3	100	105	40	1.80	
2 1/2	F37-440-CFX	83.4	120	125	50	3.00	
2 1/2	F37-44073-CF*	83.4	120	125	50	3.10	400
3	F37-448-CFX	102.5	150	155	52	5.40	
3	F37-448909-CF*	102.5	150	155	52	5.29	

* Heavy series (with lockring).

Please change suffixes according to material/surface required

Order code suffixes			
Material	Suffix surface and material	Example	Comments
Steel, zinc plated, Cr(VI)-free	CF	F37-432-CFX	
Stainless steel	SS	F37-432-SSX	
Galvanized hot dip zinc	TZN	F37-432-TZNX	on request

Parflange® F37 – ISO 6164

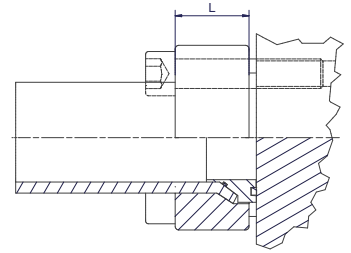
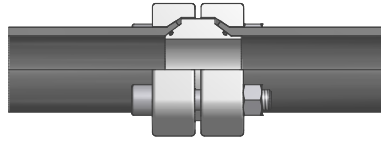

Part combination flaring ISO 6164

Flange Pressure (bar)	Size Inch	Pipe Size	Flange ISO 6164	Insert*	Sleeve
400	2	50X3.0	F37-432-CFX	IN32-50X3.0T...	SL32-60-50-CFX
	2	50X5.0	F37-432-CFX	IN32-50X5.0T...	SL32-60-50-CFX
	2	50X6.0	F37-432-CFX	IN32-50X6.0T...	SL32-60-50-CFX
	2	60X3.0	F37-432-CFX	IN32-60X3.0T...	
	2	60X5.0	F37-432-CFX	IN32-60X5.0T...	
	2	60X6.0	F37-432-CFX	IN32-60X6.0T...	
	2 1/2	60X3.0	F37-440-CFX	IN40-60X3.0T...	SL40-75-60-CFX
	2 1/2	60X5.0	F37-440-CFX	IN40-60X5.0T...	SL40-75-60-CFX
	2 1/2	60X6.0	F37-440-CFX	IN40-60X6.0T...	SL40-75-60-CFX
	2 1/2	73X7.0	F37-44073-CF	IN40-73X7.0T...	
	2 1/2	75X3.0	F37-440-CFX	IN40-75X3.0T...	
	2 1/2	75X5.0	F37-440-CFX	IN40-75X5.0T...	
	3	75X3.0	F37-448-CFX	IN48-75X3.0T...	SL48-90-75-CFX
	3	75X5.0	F37-448-CFX	IN48-75X5.0T...	SL48-90-75-CFX
	3	90X3.5	F37-448-CFX	IN48-90X3.5T...	
	3	90X5.0	F37-448-CFX	IN48-90X5.0T...	
	3	90X9.0	F37-448909-CF	IN48-90X9.0T...	

Select the complete version:

- * ...FBCF Bonded Seal version
- ...FVCF F37 Seal version
- ...TCF Tube to Tube version
- ...FCF Flat Face version

Other sizes like schedule on request.

Bolts and nuts are not included in complete part numbers.
For recommended bolts and nuts see page 168.

R - Retaining ring flange | ISO 6164 footprint

ISO 6164

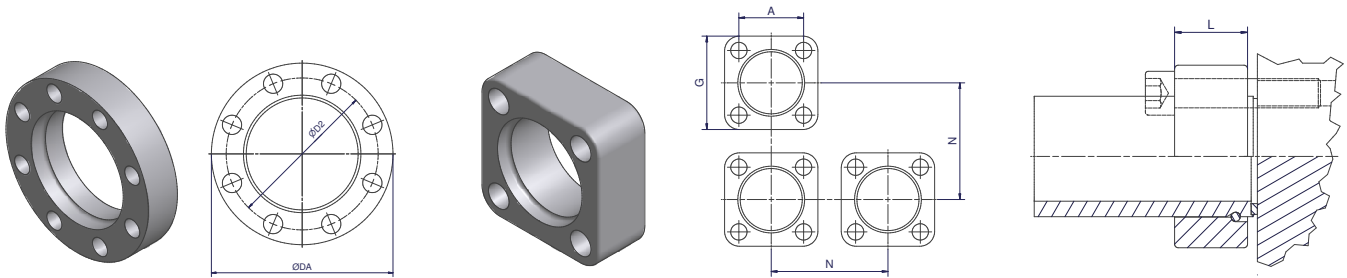

Retaining ring flange dimensions

Size Inch	Flange Order Code	A	G	N	L	Weight body (Steel) kg/1 piece	W.P. bar
2	R-432-CFX	69.3	100	105	40	1.60	400
2 1/2	R-440-CFX	83.4	120	125	50	2.90	
3	R-448-CFX	102.5	150	155	52	5.00	
4	R-464-CFX	123.7	180	185	70	9.70	
		D2	DA				
4 1/2	R-872-CFX	175.0	214		60	8.97	350
5	R-880-CFX	205.0	245		70	13.44	350
6	R-896-CFX	245.0	300		80	21.22	350
8	R-8128-350-TZNX	315.0	385		92	39.73	350
8	R-8128219.1-350-TZNX	290.0	350		92	35.56	350
10	R-8160273-350-TZNX	375.0	450		120	79.57	350
12	R-8192323.9-250-TZNX	440.0	520		120	96.81	250

Pressure rates related to flanges.
Other sizes like schedule on request.

Please change suffixes according to material/surface required

Order code suffixes		
Material	Suffix surface and material	Example
Steel, zinc plated, Cr(VI)-free	CF	R-432-CFX
Stainless steel	SS	R-432-SSX
Galvanized hot dip zinc	TZN	R-432-TZNX
Duplex	DPL	R-432-DPLX

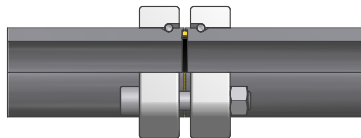

Part combination Bonded seal ISO 6164 connection

Flange pressure (bar)	Size Inch	Pipe Size	Flange	Retaining Ring	Bonded Seal
400	2	66X8.5	R-432-CFX	R32X	BS32SNX
	2 1/2	80X10.0	R-440-CFX	R40X	BS40SNX
	3	97X12.0	R-448-CFX	R48X	BS48SNX
	4	115X15.0	R-464-CFX	R64X	BS64SNX
350	4 1/2	130X15.0	R-872-CFX	R72X	BS72SNX
	5	150X15.0	R-880-CFX	R80X	BS80SNX

Bolts and nuts are not included in complete part numbers.
For recommended bolts and nuts see page 168.

PSC – Pipe seal carrier | ISO 6164 footprint

ISO 6164

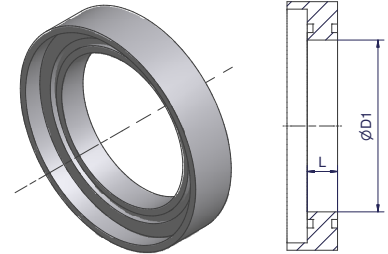

Size Inch	Pipe size	Seal carrier incl. F37 Seal	Seal carrier incl. O-Ring	L	D1	F37 Seal	O-Ring
2	66X8.5	PSC32-66X8.5VCF	PSC32-66X8.5OCF	10.0	49	F37RS32X	OR55.25X2.62X
2 1/2	80X10.0	PSC40-80X10VCF	PSC40-80X10OCF	15.0	60	F37RS40X	OR66.27X3.53X
	97X12.0	PSC48-97X12VCF	PSC48-97X12OCF	15.0	73	F37RS48X	OR78.97X3.53X
4	115X15.0	PSC64-115X15VCF	PSC64-115X15OCF	15.0	85	F37RS64X	OR94.84X3.53X
4 1/2	130X15.0	PSC72-130X15VCF	PSC72-130X15OCF	25.5	100	F37RS72X	OR107.54X3.53X
	150X15.0	PSC80-150X15VCF	PSC80-150X15OCF	38.0	120	F37RS80X	OR129.77X3.53X
6	190X20.0	PSC96-190X20VCF	PSC96-190X20OCF	40.0	150	F37RS96X	OR164.47X5.33X
8	250X25.0	PSC128-250X25VCF	PSC128-250X25OCF	40.0	200	F37RS128X	OR215.27X5.33X
8	219.1X22	on request	PSC128-219.1X22ODPL	40.0	175	on request	OR189.87X5.33X
10	273X25.4	on request	PSC160-273X25.4ODPL	40.0	222	on request	OR234.34X5.33X
12	323.9X33.32	on request	on request				

Other sizes on request.

Please change suffixes according to material/surface required

Order code suffixes		
Material	Suffix surface and material	Example
Steel, zinc plated, Cr(VI)-free, F37-Seal	VCF	PSC40-80X10VCF
Stainless steel, F37-Seal	VSS	PSC40-80X10VSS
Steel, zinc plated, Cr(VI)-free, O-Ring (NBR)	OCF	PSC40-80X10OCF
Stainless steel, O-Ring (NBR)	OSS	PSC40-80X10OSS
Duplex, O-Ring (NBR)	ODPL	PSC160-273X25.4ODPL

Example of part combination Pipe seal carrier ISO 6164 connection

Flange pressure (bar)	Size Inch	Pipe Size	Flange	Retaining Ring	Pipe seal carrier
400	2	66X8.5	R-432-CFX	R32X	PSC32-66X8.5VCF
	2 1/2	80X10.0	R-440-CFX	R40X	PSC40-80X10VCF
	3	97X12.0	R-448-CFX	R48X	PSC48-97X12VCF
	4	115X15.0	R-464-CFX	R64X	PSC64-115X15VCF
350	4 1/2	130X15.0	R-872-CFX	R72X	PSC72-130X15VCF
	5	150X15.0	R-880-CFX	R80X	PSC80-150X15VCF
	6	190X20.0	R-896-CFX	R96X	PSC96-190X20VCF
	8	250X25.0	R-8128-350-TZNX	RS128X	PSC128-250X25VCF
	8	219.1X22	R-8128219.1-350-TZNX	RS128/219.1X	PSC128-219.1X22ODPL
250	10	273X25.4	R-8160273-CFX	RS160X	PSC160-273X25.4ODPL
	12	323.9X33.32	R-8192323.9-250-TZNX	RS192/323.9X	on request

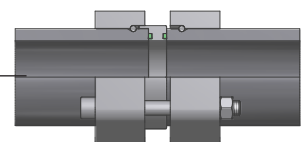

Other sizes on request

Bolts and nuts are not included in a complete part. For recommended bolts and nuts see page 168.



TFB - Flare flange connection

Tube to port connection, bonded seal

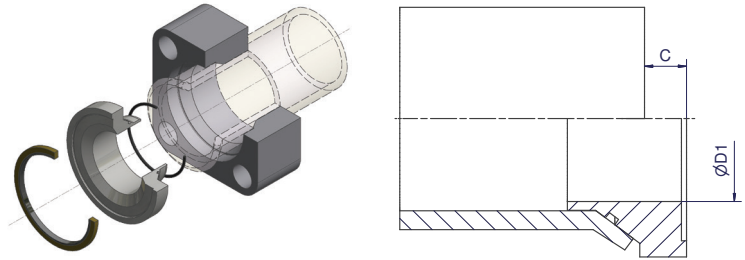

Size		Flange* incl. Insert + Bonded Seal + O-Ring Order code	D1	C	Insert incl. Bonded Seal + O-Ring Order code	Bonded Seal Order code	O-Ring Order code	Weight (Steel) kg/1kit
Inch	Tube							
2	50X3.0	F37-432-50X3.0TFBCF	42	11	IN32-50X3.0TFBCF	BS32SNX	OR44.17X1.78X	2.02
2	50X5.0	F37-432-50X5.0TFBCF	38	10	IN32-50X5.0TFBCF	BS32SNX	OR41X1.78X	2.04
2	50X6.0	F37-432-50X6.0TFBCF	35	10	IN32-50X6.0TFBCF	BS32SNX	OR41X1.78X	2.07
2	60X3.0	F37-432-60X3.0TFBCF	46	12	IN32-60X3.0TFBCF	BS32SNX	OR53.7X1.78X	2.07
2	60X5.0	F37-432-60X5.0TFBCF	46	11	IN32-60X5.0TFBCF	BS32SNX	OR50.52X1.78X	2.04
2	60X6.0	F37-432-60X6.0TFBCF	46	11	IN32-60X6.0TFBCF	BS32SNX	OR47.37X1.78X	2.03
2 1/2	60X3.0	F37-440-60X3.0TFBCF	50	12	IN40-60X3.0TFBCF	BS40SNX	OR53.7X1.78X	3.35
2 1/2	60X5.0	F37-440-60X5.0TFBCF	46	11	IN40-60X5.0TFBCF	BS40SNX	OR50.52X1.78X	3.36
2 1/2	60X6.0	F37-440-60X6.0TFBCF	46	11	IN40-60X6.0TFBCF	BS40SNX	OR47.37X1.78X	3.34
2 1/2	73X7.0	F37-440-73X7.0TFBCF	56	13	IN40-73X7.0TFBCF	BS40SNX	OR63.22X1.78X	3.33
2 1/2	75X3.0	F37-440-75X3.0TFBCF	60	10	IN40-75X3.0TFBCF	BS40SNX	OR69.57X1.78X	3.30
2 1/2	75X5.0	F37-440-75X5.0TFBCF	60	10	IN40-75X5.0TFBCF	BS40SNX	OR63.22X1.78X	3.32
3	75X3.0	F37-448-75X3.0TFBCF	66	10	IN48-75X3.0TFBCF	BS48SNX	OR69.57X1.78X	5.83
3	75X5.0	F37-448-75X5.0TFBCF	62	10	IN48-75X5.0TFBCF	BS48SNX	OR63.22X1.78X	5.99
3	90X3.5	F37-448-90X3.5TFBCF	72	15	IN48-90X3.5TFBCF	BS48SNX	OR82.27X1.78X	6.00
3	90X5.0	F37-448-90X5.0TFBCF	72	14	IN48-90X5.0TFBCF	BS48SNX	OR79X1.78X	5.96
3	90X9.0	F37-448-90X9.0TFBCF	69	17	IN48-90X9.0TFBCF	BS48SNX	OR72.75X1.78X	5.91

Other sizes on request. *Incl. adapter sleeve or jump size flange if necessary.

Please change suffixes according to material/surface required

Order code suffixes			
Material	Suffix surface and material	Example	Comments
Steel, zinc plated, Cr(VI)-free	CF	IN24-50X5.0TFBCF	
Stainless steel	SS	IN24-50X5.0TFBSS	

TFV – Flare flange connection

Tube to port connection, F37 seal

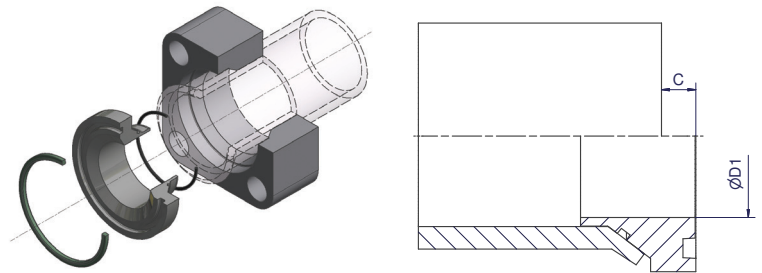

Size		Flange* incl. Insert + F37 Seal + O-Ring Order code	D1	C	Insert incl. F37 Seal + O-Ring Order code	F37 Seal Order code	O-Ring Order code	Weight (Steel) kg/1 kit
Inch	Tube							
2	50X3.0	F37-432-50X3.0TFVCF	42	11	IN32-50X3.0TFVCF	F37S32X	OR44.17X1.78X	2.02
2	50X5.0	F37-432-50X5.0TFVCF	38	10	IN32-50X5.0TFVCF	F37S32X	OR41X1.78X	2.04
2	50X6.0	F37-432-50X6.0TFVCF	35	10	IN32-50X6.0TFVCF	F37S32X	OR41X1.78X	2.07
2	60X3.0	F37-432-60X3.0TFVCF	46	12	IN32-60X3.0TFVCF	F37S32X	OR53.7X1.78X	2.07
2	60X5.0	F37-432-60X5.0TFVCF	46	11	IN32-60X5.0TFVCF	F37S32X	OR50.52X1.78X	2.04
2	60X6.0	F37-432-60X6.0TFVCF	46	11	IN32-60X6.0TFVCF	F37S32X	OR47.37X1.78X	2.03
2 1/2	60X3.0	F37-440-60X3.0TFVCF	50	12	IN40-60X3.0TFVCF	F37S40X	OR53.7X1.78X	3.35
2 1/2	60X5.0	F37-440-60X5.0TFVCF	46	11	IN40-60X5.0TFVCF	F37S40X	OR50.52X1.78X	3.36
2 1/2	60X6.0	F37-440-60X6.0TFVCF	46	11	IN40-60X6.0TFVCF	F37S40X	OR47.37X1.78X	3.34
2 1/2	73X7.0	F37-440-73X7.0TFVCF	56	13	IN40-73X7.0TFVCF	F37S40X	OR63.22X1.78X	3.33
2 1/2	75X3.0	F37-440-75X3.0TFVCF	60	10	IN40-75X3.0TFVCF	F37S40X	OR69.57X1.78X	3.30
2 1/2	75X5.0	F37-440-75X5.0TFVCF	60	10	IN40-75X5.0TFVCF	F37S40X	OR63.22X1.78X	3.32
3	75X3.0	F37-448-75X3.0TFVCF	66	10	IN48-75X3.0TFVCF	F37S48X	OR69.57X1.78X	5.83
3	75X5.0	F37-448-75X5.0TFVCF	62	10	IN48-75X5.0TFVCF	F37S48X	OR63.22X1.78X	5.99
3	90X3.5	F37-448-90X3.5TFVCF	72	15	IN48-90X3.5TFVCF	F37S48X	OR82.27X1.78X	6.00
3	90X5.0	F37-448-90X5.0TFVCF	72	14	IN48-90X5.0TFVCF	F37S48X	OR79X1.78X	5.96
3	90X9.0	F37-448-90X9.0TFVCF	69	17	IN48-90X9.0TFVCF	F37S48X	OR72.75X1.78X	5.82

Other sizes on request. *Incl. adapter sleeve or jump size flange if necessary.

Please change suffixes according to material/surface required

Order code suffixes		
Material	Suffix surface and material	Example
Steel, zinc plated, Cr(VI)-free	CF	IN32-50X5.0TFVCF
Stainless steel	SS	IN32-50X5.0TFVSS



TT - Flare Flange Connection

Tube to tube connection

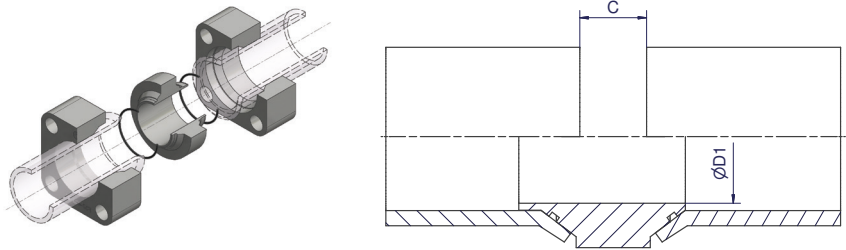

Size		2 Flanges* incl. Insert + 2 x O-Ring Order code	D1	C	Insert incl. 2 x O-Ring Order code	O-Ring Order code	Weight (Steel) kg/1 kit
Inch	Tube						
2	50X3.0	F37-432-50X3.0TTCF	42	22	IN32-50X3.0TTCF	OR44.17X1.78X	3.82
2	50X5.0	F37-432-50X5.0TTCF	38	20	IN32-50X5.0TTCF	OR41X1.78X	3.93
2	50X6.0	F37-432-50X6.0TTCF	35	20	IN32-50X6.0TTCF	OR41X1.78X	3.98
2	60X3.0	F37-432-60X3.0TTCF	46	24	IN32-60X3.0TTCF	OR53.7X1.78X	3.95
2	60X5.0	F37-432-60X5.0TTCF	46	22	IN32-60X5.0TTCF	OR50.52X1.78X	3.88
2	60X6.0	F37-432-60X6.0TTCF	46	22	IN32-60X6.0TTCF	OR47.37X1.78X	3.87
2 1/2	60X3.0	F37-440-60X3.0TTCF	50	24	IN40-60X3.0TTCF	OR53.7X1.78X	6.25
2 1/2	60X5.0	F37-440-60X5.0TTCF	46	22	IN40-60X5.0TTCF	OR50.52X1.78X	6.26
2 1/2	60X6.0	F37-440-60X6.0TTCF	45	22	IN40-60X6.0TTCF	OR47.37X1.78X	6.24
2 1/2	73X7.0	F37-440-73X7.0TTCF	56	26	IN40-73X7.0TTCF	OR63.22X1.78X	6.23
2 1/2	75X3.0	F37-440-75X3.0TTCF	60	20	IN40-75X3.0TTCF	OR69.57X1.78X	6.20
2 1/2	75X5.0	F37-440-75X5.0TTCF	60	20	IN40-75X5.0TTCF	OR63.22X1.78X	6.22
3	75X3.0	F37-448-75X3.0TTCF	66	20	IN48-75X3.0TTCF	OR69.57X1.78X	10.83
3	75X5.0	F37-448-75X5.0TTCF	62	20	IN48-75X5.0TTCF	OR63.22X1.78X	10.99
3	90X3.5	F37-448-90X3.5TTCF	72	30	IN48-90X3.5TTCF	OR82.27X1.78X	11.00
3	90X5.0	F37-448-90X5.0TTCF	72	28	IN48-90X5.0TTCF	OR79X1.78X	10.96
3	90X9.0	F37-448-90X9.0TTCF	69	34	IN48-90X9.0TTCF	OR72.75X1.78X	10.85

Other sizes on request. *Incl. adapter sleeve or jump size flange if necessary.

Please change suffixes according to material/surface required

Order code suffixes		
Material	Suffix surface and material	Example
Steel, zinc plated, Cr(VI)-free	CF	IN32-50X5.0TTCF
Stainless steel	SS	IN32-50X5.0TTSS

TF – Flare Flange Connection

Tube to port connection, flat face

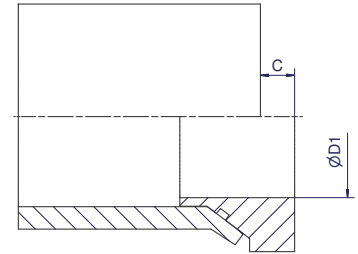
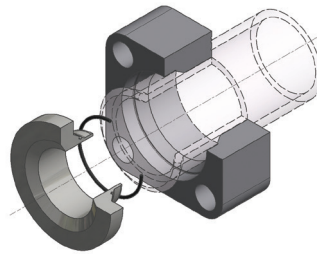

Size		Flange* incl. Insert + O-Ring Order code	D1	C	Insert incl. O-Ring Order code	O-Ring Order code	Weight (Steel) kg/1 kit
Inch	Tube						
2	50X3.0	F37-432-50X3.0TFCF	42	11	IN32-50X3.0TFCF	OR44.17X1.78X	2.02
2	50X5.0	F37-432-50X5.0TFCF	38	10	IN32-50X5.0TFCF	OR41X1.78X	2.04
2	50X6.0	F37-432-50X6.0TFCF	35	10	IN32-50X6.0TFCF	OR41X1.78X	2.07
2	60X3.0	F37-432-60X3.0TFCF	46	12	IN32-60X3.0TFCF	OR53.7X1.78X	2.07
2	60X5.0	F37-432-60X5.0TFCF	46	11	IN32-60X5.0TFCF	OR50.52X1.78X	2.04
2	60X6.0	F37-432-60X6.0TFCF	46	11	IN32-60X6.0TFCF	OR47.37X1.78X	2.03
2 1/2	60X3.0	F37-440-60X3.0TFCF	50	12	IN40-60X3.0TFCF	OR53.7X1.78X	3.35
2 1/2	60X5.0	F37-440-60X5.0TFCF	46	11	IN40-60X5.0TFCF	OR50.52X1.78X	3.36
2 1/2	60X6.0	F37-440-60X6.0TFCF	46	11	IN40-60X6.0TFCF	OR47.37X1.78X	3.34
2 1/2	73X7.0	F37-440-73X7.0TFCF	56	13	IN40-73X7.0TFCF	OR63.22X1.78X	3.33
2 1/2	75X3.0	F37-440-75X3.0TFCF	60	10	IN40-75X3.0TFCF	OR69.57X1.78X	3.30
2 1/2	75X5.0	F37-440-75X5.0TFCF	60	10	IN40-75X5.0TFCF	OR63.22X1.78X	3.32
3	75X3.0	F37-448-75X3.0TFCF	66	10	IN48-75X3.0TFCF	OR69.57X1.78X	5.83
3	75X5.0	F37-448-75X5.0TFCF	62	10	IN48-75X5.0TFCF	OR63.22X1.78X	5.99
3	90X3.5	F37-448-90X3.5TFCF	72	15	IN48-90X3.5TFCF	OR82.27X1.78X	6.00
3	90X5.0	F37-448-90X5.0TFCF	72	14	IN48-90X5.0TFCF	OR79X1.78X	5.96
3	90X9.0	F37-448-90X9.0TFCF	69	17	IN48-90X9.0TFCF	OR72.75X1.78X	5.82

Other sizes on request. *Incl. adapter sleeve or jump size flange if necessary.

Please change suffixes according to material/surface required

Order code suffixes		
Material	Suffix surface and material	Example
Steel, zinc plated, Cr(VI)-free	CF	IN32-50X5.0TFCF
Stainless steel	SS	IN32-50X5.0TFSS



SL - Sleeve

ISO 6164

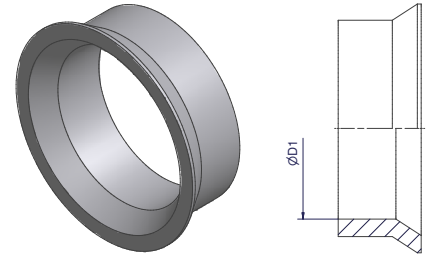

Size Inch	Tube OD	Order code	D1	Weight body (Steel) kg/1 piece
2	50	SL32-60-50-CFX	50.30	0.16
2 1/2	60	SL40-75-60-CFX	60.45	0.36
3	75	SL48-90-75-CFX	75.45	0.52

Please change suffixes according to material/surface required

Order code suffixes		
Material	Suffix surface and material	Example
Steel, zinc plated, Cr(VI)-free	CF	SL24-50-42-CFX
Stainless steel	SS	SL24-50-42-SSX

R – Retaining ring

ISO 6164

Size Inch	Tube	Order code	D	S
2	66X8.5	R32X	61.3	5.0
2 1/2	80X10.0	R40X	75.3	5.0
3	97X12.0	R48X	91.3	6.0
4	115X15.0	R64X	107.3	8.0
4 1/2	130x15.0	R72X	122.3	8.0
5	150X15.0	R80X	142.3	8.0
6	190x20.0	R96X	180.3	10.0
8	250X25.0	RS128X	236.0	12.0
8	219.1X22	RS128/219.1X	205.1	12.0
10	273X25.4	RS160X	259.0	12.0
12	323.9X33.32	RS192/323.9X	309.9	12.0

Material: Stainless steel

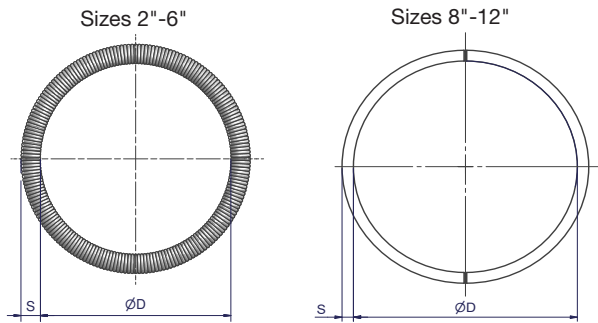

MTF-R - Male thread adapter, BSPP

ISO 6164

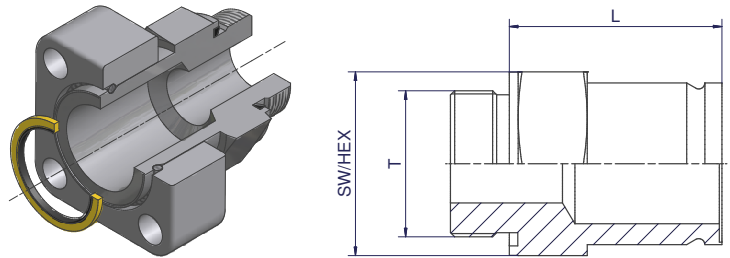

Size Inch	Tube	Complete part Order code	Body incl. ED Seal Order code	L	T (BSPP)	SW/ HEX	Weight body (Steel) kg/1 piece
2	66X8.5	R-432MTFRCF	MTF32ROMDCF	104.0	G 2 A	75	1.90
2	66X8.5	R-440MTFR112CF	MTFR32R112OMDCF	103.5	G 1 1/2 A	75	1.80
2 1/2	80X10.0	R-440MTFRCF	MTFR40ROMDCF	134.0	G 2 1/2 A	85	3.50
2 1/2	80X10.0	R-440MTFR2CF	MTFR40R2OMDCF	136.0	G 2 A	85	3.50
3	97X12.0	R-448MTFRCF	MTFR48ROMDCF	145.0	G 3 A	95	5.00

Other sizes on request.

Please change suffixes according to material/surface required

Order code suffixes		
Material	Suffix surface and material	Example
Steel, zinc plated, Cr(VI)-free	CF	R-432MTFRCF
Stainless steel	SS	R-432MTFRSS

MTF-N - Male thread adapter, NPT

ISO 6164

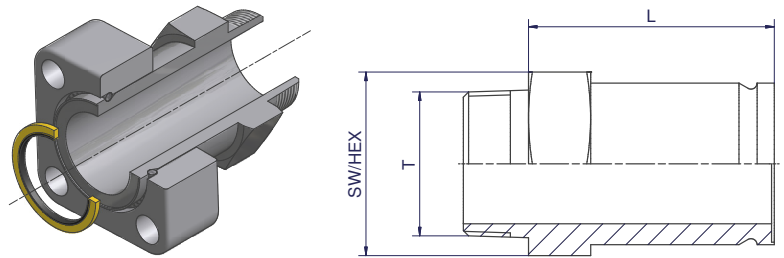

Size Inch	Tube	Complete part Order code	Body incl. ED Seal Order code	L	T (NPT)	SW/ HEX	Weight body (Steel) kg/1 piece
2	66X8.5	R-432MTFNCF	MTF32NCFX	100.4	2-11.5	75	2.40
2 1/2	80X10.0	R-440MTFNCF	MTF40NCFX	130.0	2 1/2-8	85	3.40
3	97X12.0	R-448MTFNCF	MTF48NCFX	141.2	3-8	95	4.90

Other sizes on request.

Please change suffixes according to material/surface required

Order code suffixes		
Material	Suffix surface and material	Example
Steel, zinc plated, Cr(VI)-free	CF	R-432MTFNCF
Stainless steel	SS	R-432MTFNSS



FTF-R - Female thread adapter, BSPP

ISO 6164

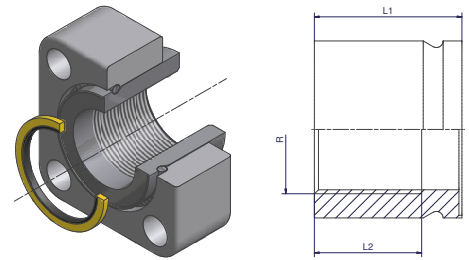

Size Inch	Tube	Complete part Order code	Body Order code	L1	L2	R (BSPP)	Weight body (Steel) kg/1 piece
2	66X8.5	R-432FTFRCF	FTF32RCFX	55	40	G 1 1/2	0.75
2 1/2	80X10.0	R-440FTFRCF	FTF40RCFX	80	40	G 2	1.52
3	97X12.0	R-448FTFRCF	FTF48RCFX	85	50	G 2 1/2	2.11

Other sizes on request.

Please change suffixes according to material/surface required

Order code suffixes		
Material	Suffix surface and material	Example
Steel, zinc plated, Cr(VI)-free	CF	R-432FTFRCF
Stainless steel	SS	R-432FTFRSS

WA – Weld adapter connection

ISO 6164

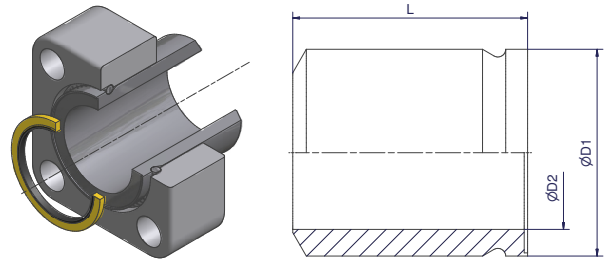

Size Inch	Tube	Complete Part Order code	Retaining Ring	Bonded Seal	Flange Order code	Weld Adapter Body Order code	D1	D2	L	Weight (Steel) kg/1 kit
2	48.3X5.6	R-432WA-48.3X5.6S	R32X	BS32SNX	R-432-CFX	WA32-48.3X5.6SX	66	37	90	2.90
2	50X9.0	R-432WA-50X9.0S	R32X	BS32SNX	R-432-CFX	WA32-50X9.0SX	66	32	90	3.11
2	60X3.0	R-432WA-60X3.0S	R32X	BS32SNX	R-432-CFX	WA32-60X3.0SX	66	49	90	2.39
2	60X5.0	R-432WA-60X5.0S	R32X	BS32SNX	R-432-CFX	WA32-60X5.0SX	66	50	90	2.49
2	60X6.0	R-432WA-60X6.0S	R32X	BS32SNX	R-432-CFX	WA32-60X6.0SX	66	48	90	2.60
2	60X8.0	R-432WA-60X8.0S	R32X	BS32SNX	R-432-CFX	WA32-60X8.0SX	66	44	90	2.78
2	60X10.0	R-432WA-60X10.0S	R32X	BS32SNX	R-432-CFX	WA32-60X10.0SX	66	40	90	2.96
2	60.3X2.8	R-432WA-60.3X2.8S	R32X	BS32SNX	R-432-CFX	WA32-60.3X2.8SX	66	49	90	2.37
2	60.3X3.9	R-432WA-60.3X3.9S	R32X	BS32SNX	R-432-CFX	WA32-60.3X3.9SX	66	49	90	2.45
2	60.3X5.5	R-432WA-60.3X5.5S	R32X	BS32SNX	R-432-CFX	WA32-60.3X5.5SX	66	49	90	2.54
2	60.3X8.7	R-432WA-60.3X8.7S	R32X	BS32SNX	R-432-CFX	WA32-60.3X8.7SX	66	43	90	2.84
2	60.3X11.1	R-432WA-60.3X11.1S	R32X	BS32SNX	R-432-CFX	WA32-60.3X11.1SX	66	38	90	3.04
2	66X8.5	R-432WA-66X8.5S	R32X	BS32SNX	R-432-CFX	WA32-66X8.5SX	66	49	75	2.45
2 1/2	65X8.0	R-440WA-65X8.0S	R40X	BS40SNX	R-440-CFX	WA40-65X8.0SX	80	49	105	5.10
2 1/2	65X8.5	R-440WA-65X8.5S	R40X	BS40SNX	R-440-CFX	WA40-65X8.5SX	80	59	105	4.59
2 1/2	73X7.0	R-440WA-73X7.0S	R40X	BS40SNX	R-440-CFX	WA40-73X7.0SX	80	59	105	4.20
2 1/2	75X5.0	R-440WA-75X5.0S	R40X	BS40SNX	R-440-CFX	WA40-75X5.0SX	80	60	105	4.37
2 1/2	76.1X6.3	R-440WA-76.1X6.3S	R40X	BS40SNX	R-440-CFX	WA40-76.1X6.3SX	80	60	105	4.45
2 1/2	76.1X12.5	R-440WA-76.1X12.5S	R40X	BS40SNX	R-440-CFX	WA40-76.1X12.5SX	80	51	105	5.17
2 1/2	80X10.0	R-440WA-80X10.0S	R40X	BS40SNX	R-440-CFX	WA40-80X10.0SX	80	60	90	4.40
3	76.1X12.5	R-448WA-76.1X12.5S	R48X	BS48SNX	R-448-CFX	WA48-76.1X12.5SX	97	51	120	8.18
3	80X10.0	R-448WA-80X10.0S	R48X	BS48SNX	R-448-CFX	WA48-80X10.0SX	97	60	120	8.07
3	88.9X3.1	R-448WA-88.9X3.1S	R48X	BS48SNX	R-448-CFX	WA48-88.9X3.1SX	97	73	120	7.18
3	88.9X5.5	R-448WA-88.9X5.5S	R48X	BS48SNX	R-448-CFX	WA48-88.9X5.5SX	97	73	120	7.47
3	88.9X7.7	R-448WA-88.9X7.7S	R48X	BS48SNX	R-448-CFX	WA48-88.9X7.7SX	97	74	120	7.67
3	88.9X8.8	R-448WA-88.9X8.8S	R48X	BS48SNX	R-448-CFX	WA48-88.9X8.8SX	97	71	120	7.90
3	88.9X11.1	R-448WA-88.9X11.1S	R48X	BS48SNX	R-448-CFX	WA48-88.9X11.1SX	97	67	120	8.34
3	88.9X12.5	R-448WA-88.9X12.5S	R48X	BS48SNX	R-448-CFX	WA48-88.9X12.5SX	97	64	120	8.60
3	88.9X15.2	R-448WA-88.9X15.2S	R48X	BS48SNX	R-448-CFX	WA48-88.9X15.2SX	97	59	120	9.00
3	90X3.5	R-448WA-90X3.5S	R48X	BS48SNX	R-448-CFX	WA48-90X3.5SX	97	73	120	7.19
3	90X5.0	R-448WA-90X5.0S	R48X	BS48SNX	R-448-CFX	WA48-90X5.0SX	97	73	120	7.50
3	90X9.0	R-448WA-90X9.0S	R48X	BS48SNX	R-448-CFX	WA48-90X9.0SX	97	72	120	7.85
3	97X12.0	R-448WA-97X12.0S	R48X	BS48SNX	R-448-CFX	WA48-97X12.0SX	97	73	110	7.65
4	100X4.0	R-464WA-100X4.0S	R64X	BS64SNX	R-464-CFX	WA64-100X4.0SX	115	85	130	13.44
4	101.6X8.1	R-464WA-101.6X8.1S	R64X	BS64SNX	R-464-CFX	WA64-101.6X8.1SX	115	85	130	12.49
4	101.6X16.0	R-464WA-101.6X16.0S	R64X	BS64SNX	R-464-CFX	WA64-101.6X16.0SX	115	85	120	13.73
4	114.3X4.5	R-464WA-114.3X4.5S	R64X	BS64SNX	R-464-CFX	WA64-114.3X4.5SX	115	80	120	14.40
4	114.3X12.5	R-464WA-114.3X12.5S	R64X	BS64SNX	R-464-CFX	WA64-114.3X12.5SX	115	85	120	12.37
4	114.3X17.1	R-464WA-114.3X17.1S	R64X	BS64SNX	R-464-CFX	WA64-114.3X17.1SX	115	85	120	13.90
4	115X4.0	R-464WA-115X4.0S	R64X	BS64SNX	R-464-CFX	WA64-115X4.0SX	115	85	120	12.36
4	115X15.0	R-464WA-115X15.0S	R64X	BS64SNX	R-464-CFX	WA64-115X15.0SX	115	85	120	13.87
4 1/2	130X15.0	R-872WA-130X15.0S	R72X	BS72SNX	R-872-CFX	WA72-130X15SX	130	100	125	14.02
5	150X15.0	R-880WA-150X15.0S	R80X	BS80SNX	R-880-CFX	WA80-150X15SX	150	120	110	18.55
6	190X20.0	R-896WA-190X20.0S	R96X	PSC96-190x20CFX	R-896-CFX	WA96-190x20.0SX	190	150	175	32.70

Other sizes on request.

Please change suffixes according to material/surface required

Order code suffixes		
Material	Suffix surface and material	Example
Steel	S	R-432WA-66X8.5S
Stainless steel	SS	R-432WA-66X8.5SS



BF - Bulkhead flange

ISO 6164

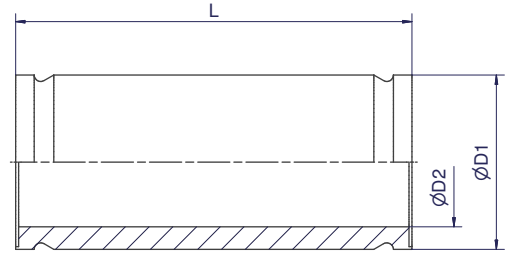
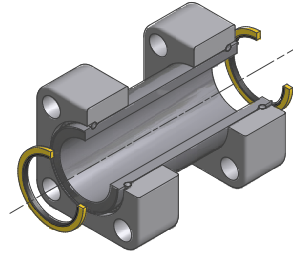

Size Inch	Complete Part Order code	Bulkhead Body Order code	D1	D2	L	Weight body (Steel) kg/1 piece
2	R-432BFS	BF32SX	66	49	210	2.45
2 1/2	R-440BFS	BF40SX	80	60	220	3.70
3	R-448BFS	BF48SX	97	73	240	7.85
4	R-464BFS	BF64SX	115	85	260	9.35
5	R-880BFS	BF80SX	150	120	260	10.53

Other sizes on request.

Please change suffixes according to material/surface required

Order code suffixes		
Material	Suffix surface and material	Example
Steel	S	R-432BFS
Stainless steel	SS	R-432BFSS

RF – Reducer flange

ISO 6164

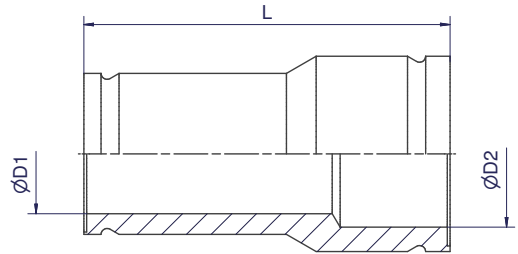
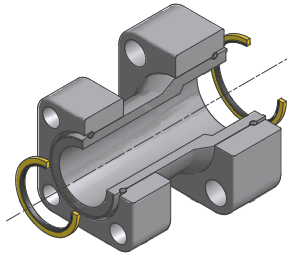

Size Inch	Complete Part Order code	Reducer Body Order code	D1	D2	L	Weight body (Steel) kg/1 piece
2 1/2 - 2	R-440-432RFCF	RF40-32CFX	49	60	150	2.2
3 - 2	R-448-432RFCF	RF48-32CFX	49	73	180	3.4
3 - 2 1/2	R-448-440RFCF	RF48-40CFX	60	73	180	3.7
4 - 3	R-464-448RFCF	RF64-48CFX	73	85	200	6.1
5 - 3	R-880-448RFCF	RF80-48CFX	73	120	200	8.0
5 - 4	R-880-464RFCF	RF80-64CFX	85	120	220	10.3
6 - 5	R-896-880RFCF	RF96-80CFX	120	150	250	18.3

Other sizes on request.

Please change suffixes according to material/surface required

Order code suffixes		
Material	Suffix surface and material	Example
Steel, zinc plated, Cr(VI)-free	CF	R-432-424RFCF
Stainless steel	SS	R-432-424RFSS



FB90 - 90° Flange bend

ISO 6164

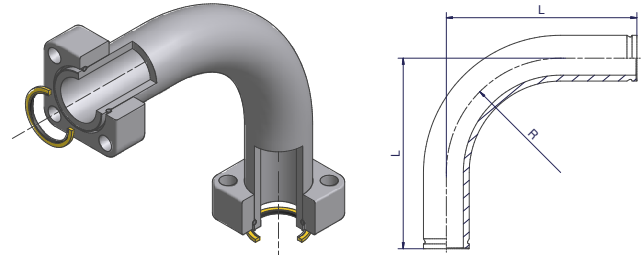

Size Inch	Tube	Complete Part Order code	90° Flange Bend Order code	L	R	Weight body (Steel) kg/1 piece
2	66X8.5	R-432FB90CF	FB90-32CFX	275	165	5.72
2 1/2	80X10.0	R-440FB90S*	FB90-40SX*	370	200	11.20
3	97X12.0	R-448FB90S*	FB90-48SX*	450	243	19.90

*only available as Steel version

Please change suffixes according to material/surface required

Order code suffixes			
Tube material	Suffix surface and material	Example	Comments
Steel, zinc plated, Cr(VI)-free	CF	R-432FB90CF	
Steel, black phpsphated	SX	R-440FB90S	
Stainless steel	SS	R-432FB90SS	on request

FB45 - 45° Flange bend

ISO 6164

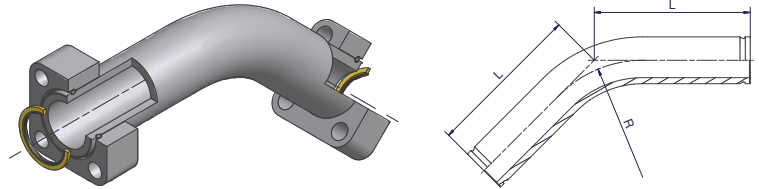

Size Inch	Tube	Complete Part Order code	45° Flange Bend Order code	L	R	Weight body (Steel) kg/1 piece
2	66X8.5	R-432FB45CF	FB45-32CFX	220	165	5.16
2 1/2	80X10.0	R-440FB45S	FB45-40SX	240	200	8.07
3	97X12.0	R-448FB45S	FB45-48SX	260	243	12.70

Available on request.

Please change suffixes according to material/surface required

Order code suffixes			
Tube material	Suffix surface and material	Example	Comments
Steel, zinc plated, Cr(VI)-free	CF	R-432FB45CF	
Steel, black phosphated	SX	R-440FB45S	
Stainless steel	SS	R-432FB45SS	on request



LF - Elbow flange

ISO 6164

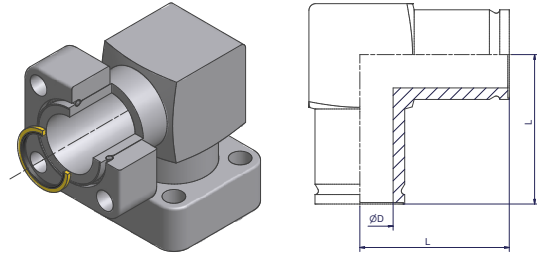

Size Inch	Complete Part Order code	Elbow Flange body Order code	D	L	Weight body (Steel) kg/1 piece
2	R-432LFCF	LF32CFX	49	110	4.02
2 1/2	R-440LFCF	LF40CFX	60	130	5.79
3	R-448LFCF	LF48CFX	73	160	10.76

Please change suffixes according to material/surface required

Order code suffixes		
Material	Suffix surface and material	Example
Steel, zinc plated, Cr(VI)-free	CF	R-432LFCF
Stainless steel	SS	R-432LFSS

TF - TEE flange

ISO 6164

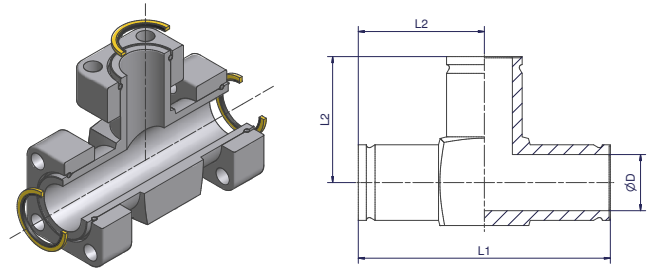

Size Inch	Complete Part Order code	Tee Flange body Order code	D	L1	L2	Weight body (Steel) kg/1 piece
2	R-432TFCF	TF32CFX	49	220	110	4.53
2 1/2	R-440TFCF	TF40CFX	60	260	130	8.70
3	R-448TFCF	TF48CFX	73	320	160	12.81

Please change suffixes according to material/surface required

Order code suffixes		
Material	Suffix surface and material	Example
Steel, zinc plated, Cr(VI)-free	CF	R-432TFCF
Stainless steel	SS	R-432TFSS



LB - Flange L-block

ISO 6164

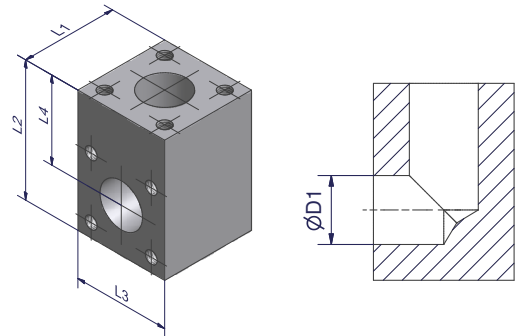

Size Inch	Order code	D1	L1	L2	L3	L4	Weight (Steel) kg/1 piece
2	LB432CFX	49	100	140	100	90	8.72
2 1/2	LB440CFX	60	120	160	120	100	14.10
3	LB448SX	73	150	200	150	125	28.10
4	LB464SX	85	180	240	180	150	48.60
5	LB880SX*	120	260	300	260	170	131.65
6	LB896SX*	150	300	360	300	210	203.00

Other sizes on request.
 Blocks only for use with F37 Components
 *only available as Steel version

Please change suffixes according to material/surface required

Order code suffixes		
Material	Suffix surface and material	Example
Steel, zinc plated, Cr(VI)-free	CF	LB432CFX *not in CF available
Steel	S	LB432SX
Stainless steel	SS	LB432SSX

TB – Flange T-block

ISO 6164

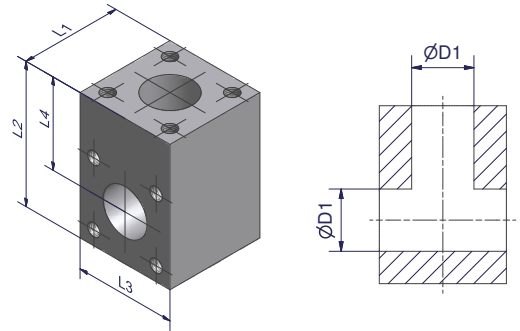

Size Inch	Order code	D1	L1	L2	L3	L4	Weight (Steel) kg/1 piece
2	TB432CFX	49	100	140	100	90	8.03
2 1/2	TB440CFX	60	120	160	120	100	12.90
3	TB448SX	73	150	200	150	125	25.80
4	TB464SX	85	180	240	180	150	40.70
4 1/2	TB872SX	100	220	250	220	140	74.00
5	TB880SX*	120	260	300	260	170	122.00
6	TB896SX*	150	300	360	300	210	186.00

Other sizes on request.
Blocks only for use with F37 Components

Please change suffixes according to material/surface required

Order code suffixes		
Material	Suffix surface and material	Example
Steel, zinc plated, Cr(VI)-free	CF	TB432CFX *not in CF available
Steel	S	TB432SX
Stainless steel	SS	TB432SSX



TBR - Flange T-block reducer

ISO 6164

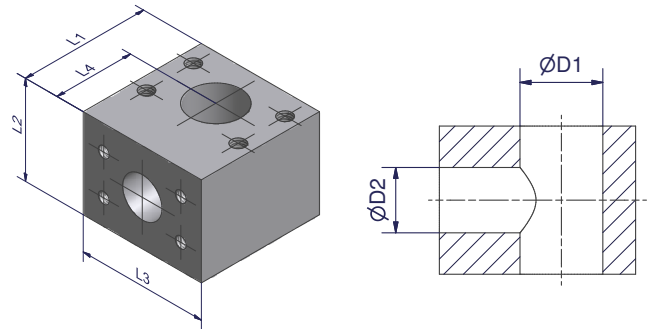

Size Inch	Order code	D1	D2	L1	L2	L3	L4	Weight (Steel) kg/1 piece
2 1/2 - 2	TBR440-432-440CFX	60	49	150	100	120	90	10.2
3 - 2 1/2	TBR448-440-448CFX	73	60	185	120	150	110	19.2
3 - 2	TBR448-432-448CFX	73	49	175	100	150	100	15.2
4 - 3	TBR464-448-464SX	85	73	225	180	180	135	35.2
4 - 2 1/2	TBR464-440-464SX	85	60	215	120	180	125	26.9
4 - 2	TBR464-432-464SX	85	49	200	100	180	110	21.0

Other sizes on request.
Bkocks only for use with F37 Components

Please change suffixes according to material/surface required

Order code suffixes		
Material	Suffix surface and material	Example
Steel, zinc plated, Cr(VI)-free	CF	TBR448-432-448CFX
Steel	S	TBR448-432-448SX
Stainless steel	SS	TBR448-432-448SSX

BFV – Blind flange

ISO 6164

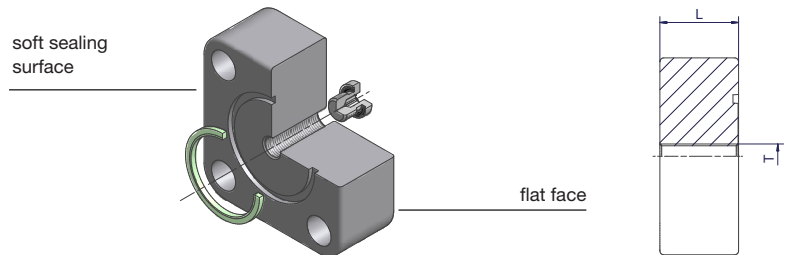

Size Inch	Flange incl. VSTI-ED and Soft Seal Order code	L	T	Weight (Steel) kg/1 piece
2	F37-432BFVCF	40.0	G 1/4	2.75
2 1/2	F37-440BFVCF	50.0	G 1/4	4.90
3	F37-448BFVCF	52.0	G 1/4	8.15
4	F37-464BFVCF	70.0	G 1/4	11.55
4 1/2	F37-872BFVCF	60.0	G 1/4	15.41
5	F37-880BFVCF	50.0	G 1/4	16.74
6	F37-896BFVCF	80.0	G 1/4	39.95
8	F37-8128BFVCF	92.0	G 1/4	76.87
10	F37-8160BFVCF	90.0	G 1/4	102.43

Other sizes on request.

Please change suffixes according to material/surface required

Order code suffixes		
Material	Suffix surface and material	Example
Steel, zinc plated, Cr(VI)-free	CF	F37-432BFVCF
Stainless steel	SS	F37-432BFVSS



BS - Bonded seal

ISO 6164

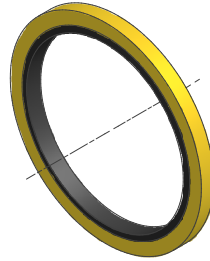

Size Inch	Steel	Stainless Steel
2	BS32SNX	BS32SSNX
2 1/2	BS40SNX	BS40SSNX
3	BS48SNX	BS48SSNX
4	BS64SNX	BS64SSNX
4 1/2	BS72SNX	BS72SSNX
5	BS80SNX	BS80SSNX

Sealing: NBR
Other sealing materials like FKM on request.

F37S/F37RS - F37 Seal

ISO 6164

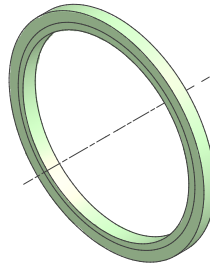

Size Inch	F37S (F37 seal for flaring system)	F37RS (F37 seal for retaining ring system)
2	F37S32X	F37RS32X
2 1/2	F37S40X	F37RS40X
3	F37S48X	F37RS48X
4	-	F37RS64X
4 1/2	-	F37RS72X
5	-	F37RS80X
6	-	F37RS96X
8	-	F37RS128X
10	-	F37RS160SCHXXSX

Other sizes on request.
Sealing: Polyurethane
Material properties and applications see page 20.

AO - Adapter bonded seal/F37 seal/O-Ring

ISO 6164

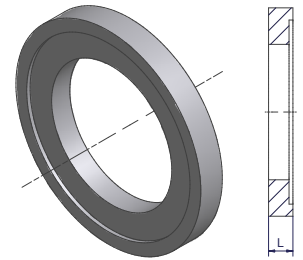

Size Inch	Adapter* Order code	L	Weight (Steel) kg/1 piece
2	AO32CFX	7	0.10
2 1/2	AO40CFX	7	0.14
3	AO48CFX	7	0.20
4	AO64CFX	7	0.35
4 1/2	AO72CFX	7	0.30
5	AO80CFX	7	0.32

*Part excluding seals.
For assembling add L to the corresponding bolt length.

Please change suffixes according to material/surface required

Order code suffixes		
Material	Suffix surface and material	Example
Steel, zinc plated, Cr(VI)-free	CF	AO32CFX
Stainless steel	SS	AO32SSX



TBT - Tee between bonded seal

ISO 6164

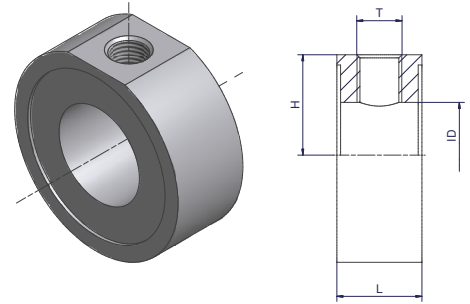

Size Inch	Order code	L	H	T	ID	Weight (Steel) kg/1 piece
2	TBT32-1/4CFX	25	35	G 1/4	41	0.51
2	TBT32-1/2CFX	40	34	G 1/2	38	0.87
2 1/2	TBT40-1/4CFX	30	42	G 1/4	60	0.63
3	TBT48-1/4CFX	30	50	G 1/4	72	0.90

*Part excluding seals.
For testpoints and diagnostic test equipment see catalogue 4100, Industrial Tube Fittings Europe.
For assembling add L to the corresponding bolt length.

Alternative versions on request.

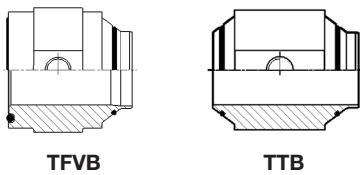

TFVB

TTB

Please change suffixes according to material/surface required

Order code suffixes		
Material	Suffix surface and material	Example
Steel, zinc plated, Cr(VI)-free	CF	TBT32-1/2CFX
Stainless steel	SS	TBT32-1/2SSX

Bolts and nuts for flange

ISO 6164



F37 Flare Flange

Size Inch	Flange	F37 Seal/Flat Face/Bonded Seal		Nut
		Recommended bolts Tube to Port	Recommended bolts Tube to Tube	
2	F37-432-CFX	4 x ZYLS16X65	4 x ZYLS16X110	4 x ISO4032-M16
2 1/2	F37-440-CFX	4 x ZYLS20X80	4 x ZYLS20X140	4 x ISO4032-M20
3	F37-448-CFX	4 x ZYLS24X90	4 x ZYLS24X150	4 x ISO4032-M24
3	F37-448909-CFX	4 x ZYLS24X110	4 x ZYLS24X190	4 x ISO4032-M24

Retaining Ring Flange

Size Inch	Flange	Flat Face/Bonded Seal		Pipe Seal Carrier (PSC)		Nut
		Recommended bolts Tube to Port	Recommended bolts Tube to Tube	Recommended bolts Tube to Port	Recommended bolts Tube to Tube	
2	R-432-CFX	4 x ZYLS16X65	4 x ZYLS16X110	4 x ZYLS16X75	4 x ZYLS16X130	4 x ISO4032-M16
2 1/2	R-440-CFX	4 x ZYLS20X80	4 x ZYLS20X140	4 x ZYLS20X95	4 x ZYLS20X150	4 x ISO4032-M20
3	R-448-CFX	4 x ZYLS24X90	4 x ZYLS24X150	4 x ZYLS24X100	4 x ZYLS24X160	4 x ISO4032-M24
4	R-464-CFX	4 x ZYLS30X120	4 x ZYLS30X190	4 x ZYLS30X130	4 x ZYLS30X200	4 x ISO4032-M30
4 1/2	R-872-CFX	8 x ZYLS20X90	8 x ZYLS20X160	8 x ZYLS20X115	8 x ZYLS20X190	8 x ISO4032-M20
5	R-880-CFX	8 x ZYLS24X110	8 x ZYLS24X190	8 x ZYLS24X145	8 x ZYLS24X220	8 x ISO4032-M24
6	R-896-CFX	-	-	8 x ZYLS30X155	8 x ZYLS30X230	8 x ISO4032-M30

Solid Retaining Ring Flange

Size Inch	Flange	Flat Face/Bonded Seal		Pipe Seal Carrier (PSC)		Nut
		Recommended bolts Tube to Port	Recommended bolts Tube to Tube	Recommended bolts Tube to Port	Recommended bolts Tube to Tube	
8	R-8128-350-TZNX	-	-	8 x ZYLS36X180	8 x ZYLS36X260	8 x ISO4032-M36
8	R-8128219.1-350-TZNX	-	-	8 x ZYLS30X170	8 x ZYLS30X260	8 x ISO4032-M30
10	R-8160273.1-350-TZNX	-	-	12 x ZYLS36X200	12 x ZYLS36X320	12 x ISO4032-M36
12*	R-8192323.9-250-TZNX	16 x ZYLS42X210	16 x ZYLS42X330	-	-	16 x ISO4032-M42

*For 12" sealgroove in tube end face integrated (no bonded seal/seal carrier)

Bolt length for 12" calculated by using Nordlock washer.

Bolts and nuts are not included in complete part numbers.

Latest information about nuts and bolts see www.parker.com/hpce -> Resources -> Installation Guides & Materials

Please add the suffixes according to the bolt quality

	Steel		Stainless Steel
Grade	8.8 zinc plated (VZX)	10.9 zinc flaked (TNFLX)	A4-80X
Bolt	ZYLS16X60VZX	ZYLS16X60109ZNFLX	ZYLS16X60A4-80X
Nut	ISO4032-M12-8VZX	ISO4032-M12-10ZNFLX	ISO4032-M12-80X

Bolt grade 10.9 recommended.
Bolt grade 8.8 can affect the pressure capability.



KH - Ball valve drilled and tapped for ISO 6164 flanges

ISO 6164

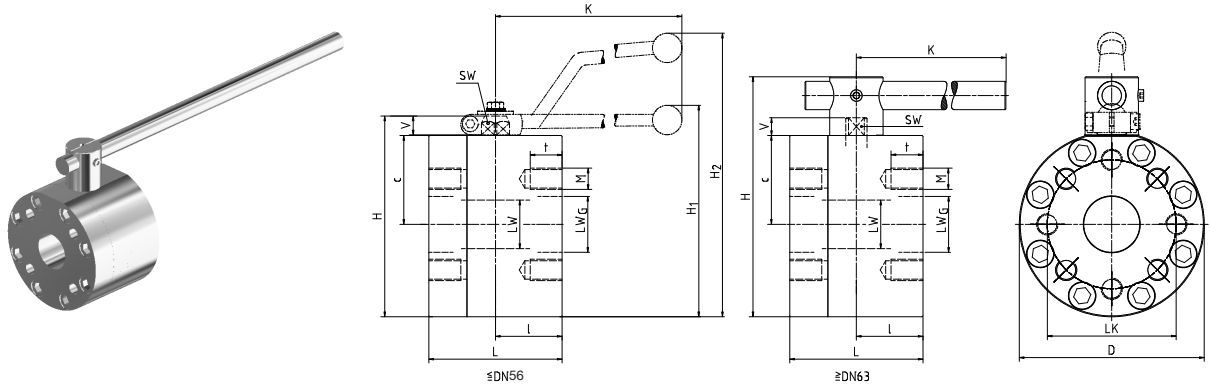

Material Steel

Size Inch	Order Code	DN	LW	LWG	L	I	D	H	c	V	K	SW	LK	M	t	H2	Material Code	Lever	Weight kg	W.P. bar
2	KH432-48CF	50	48	43	123	58	198	210	94	17	306	17	98	4x M16	25.5	283	212A	St	24.90	400
2 1/2	KH440-48CF	56	48	53	123	58	198	210	94	17	306	17	118	4x M20	31.0	283	212A	St	26.60	400
3	KH448-63CF	65	65	63	150	75	208	270	100	20	600	16	145	4x M24	36.0	-	282A	St	36.00	350
4	KH464-76CF	80	76	76	170	78	258	315	115	26	600	19	175	4x M30	35.0	-	282A	St	63.00	400
4	KH464-88CF	90	100	86	170	85	260	327	122	26	900	24	175	4x M30	31.0	-	282A	St	61.00	350
4 1/2	KH872-100CF	100	100	100	170	85	260	327	122	26	900	24	175	8x M20	33.0	-	282A	St	70.00	350
5	KH880-118CF	125	118	118	210	105	300	380	140	32	900	36	205	8x M24	34.0	-	282A	St	99.00	350
6	KH896-150CF	150	150	150	285	130	390	475	190	32	900	36	245	8x M30	46.0	-	282A	St	225.00	350
8	KH8128-200CF	200	192	200	378	150	456	598	223	61	940	46	315	8x M36	55.0	-	242A	St	395.00	350

Other sizes on request.

Please change suffixes according to material/surface required

Order code suffixes		
Material	Suffix surface and material	Example
Steel, zinc plated, Cr(VI)-free	CF	KH432-48CF

	Material		
	212A	282A	242A
Body	Steel	Steel	Steel
Ball	Steel	Steel	Stainless Steel
Stem	Steel	Stainless Steel	Stainless Steel
Ball seats	POM	POM	POM
O-Ring	NBR	NBR	NBR
Tmin / T max	-10°C / 100°C	-10°C / 100°C	-10°C / 100°C

KH – Ball valve drilled and tapped for ISO 6164 flanges

ISO 6164

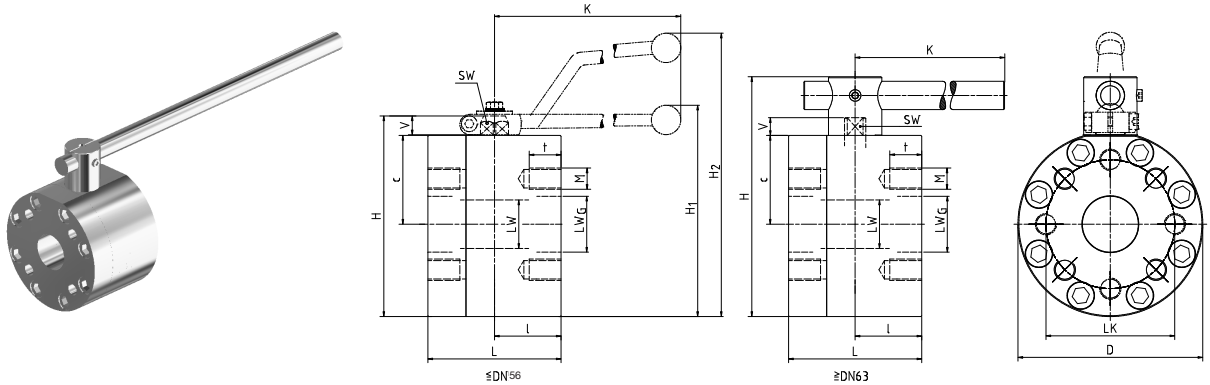

Material Stainless Steel

Size Inch	Order Code	DN	LW	LWG	L	I	D	H	c	V	K	SW	LK	M	t	H1	Lever	Weight kg	W.P. bar
2	KH432-48SS	50	48	43	123	58	198	210	94	17	320	17	98	4x M16	25.5	219	Al	24.90	400
2 1/2	KH440-48SS	56	48	53	123	58	198	210	94	17	320	17	118	4x M20	31.0	219	Al	26.60	400
3	KH448-63SS	65	65	63	150	75	208	270	100	20	600	16	145	4x M24	36.0	-	St	36.00	350
4	KH464-76SS	80	76	76	170	78	258	315	115	26	600	19	175	4x M30	35.0	-	St	63.00	400
4	KH464-88SS	90	100	86	170	85	260	327	122	26	900	24	175	4x M30	31.0	-	St	61.00	350
4 1/2	KH872-100SS	100	100	100	170	85	260	327	122	26	900	24	175	8x M20	33.0	-	St	70.00	350
5	KH880-118SS	125	118	118	210	105	300	380	140	32	900	36	205	8x M24	34.0	-	St	99.00	350
6	KH896-132SS*	150	150	132	285	130	390	475	190	32	900	36	245	8x M30	46.0	-	St	225.00	350
6	KH896-150SS	150	150	150	285	130	390	475	190	32	900	36	245	8x M30	46.0	-	St	225.00	350
8	KH8128-200SS*	200	192	200	378	150	456	598	223	61	940	46	315	8x M36	55.0	-	St	395.00	350

Other sizes on request.

Please change suffixes according to material/surface required

Order code suffixes		
Material	Suffix surface and material	Example
Stainless steel	SS	KH432-48SS

	Material 442A
Body	Stainless Steel
Ball	Stainless Steel
Stem	Stainless Steel
Ball seats	POM
O-Ring	NBR
Tmin / T max	-30°C / 100°C

*For these ball valves Tmin / Tmax = -10°C / 100°C



KH-R - Ball valve with ISO 6164 flanges

ISO 6164

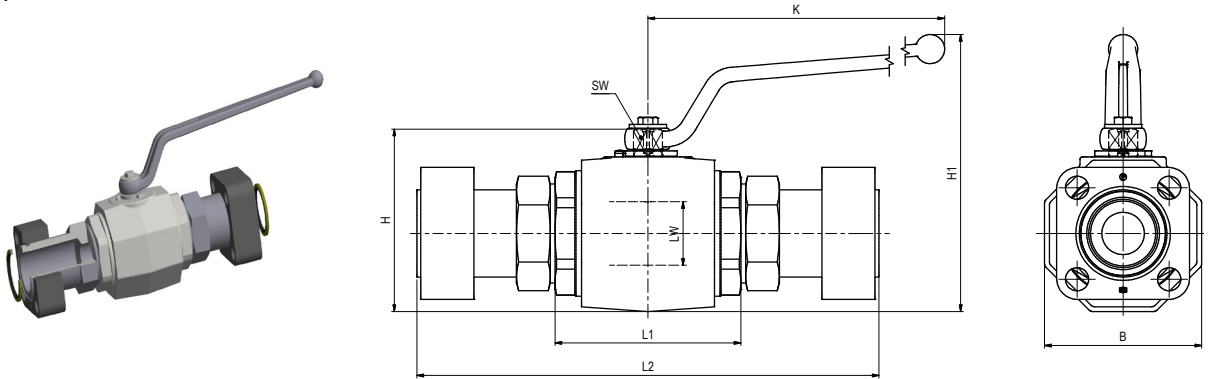

Material Steel

Size Inch	Complete part Order code	Valve body Order code	LW	L1	L2	B	H	SW	K	H1	Weight (Steel) kg/1 kit	W.P. bar
2	KH-R-432-48CF	KH-R-32-48CF	48	140	348.0	118	138	17	306	210	15.2	400

Other sizes on request.

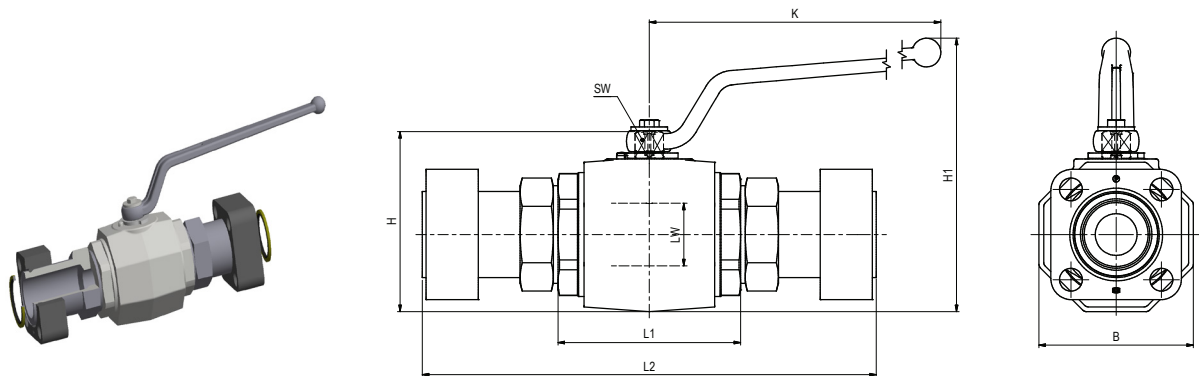

Material Stainless Steel

Size Inch	Complete part Order code	Valve body Order code	LW	L1	L2	B	H	SW	K	H1	Weight (Steel) kg/1 kit	W.P. bar
2	KH-R-432-48SS	KH-R-32-48SS	48	140	348.0	132	145	17	228	219	17.3	400

Other sizes on request.

Please change suffixes according to material/surface required

Order code suffixes		
Material	Suffix surface and material	Example
Steel, zinc plated, Cr(VI)-free	CF	KH-R-432-48CF
Stainless steel	SS	KH-R-432-48SS

	Material 112A	Material 442A
Body	Steel	Stainless Steel
Ball	Steel	Stainless Steel
Stem	Steel	Stainless Steel
Ball seats	POM	POM
O-Ring	NBR	NBR
Tmin / T max	-20°C / 100 °C	-30°C / 100°C

RHD-R - Non return valves

ISO 6164

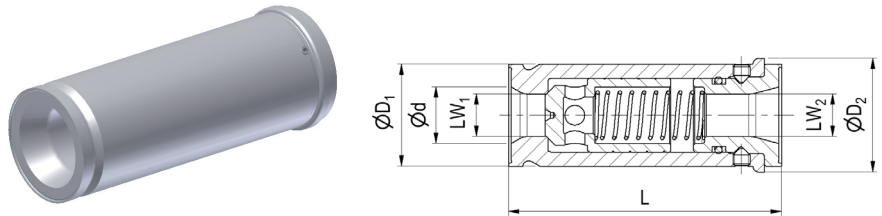

Size Inch	Complete part Order code	Valve body Order code	L	D1	D2	d	LW1	LW2	Weight body (Steel) kg/1 piece	W.P. bar
2	RHD-R-432-0.5BCF	RHD-R-32-0.5BCF	180.1	66	70.5	49	40	36.4	2.54	420

Opening pressure 0.5 bar.
 Other pressure rates on request.
 Complete Part = body + flanges + retaining rings + bonded seals.

Please change suffixes according to material/surface required

Order code suffixes		
Material	Suffix surface and material	Example
Steel, zinc plated, Cr(VI)-free	CF	RHD-R-432-0.5BCF
Stainless steel	SS	RHD-R-432-0.5BSS

	Materials
Body	Steel / Stainless steel
Piston	Steel
O-Ring	NBR
Tmin / T max	-10°C / 100 °C





Pipes and tubes



For your safety!

Under certain circumstances, tubes, fittings and flanges can be subjected to extreme loadings such as vibration and uncontrolled pressure peaks.

Only by using genuine Parker components and following Parker assembly instructions you can be assured of the reliability and safety of the products and their conformity to the applicable standards.

Failure to follow this rule can adversely affect the functional safety and reliability of products, cause personal injury, property damage, and result in loss of your guarantee rights.

Subject to alteration

© Copyright 2023, Parker Hannifin Corporation. All Rights Reserved.

	Page
Introduction	176
Technical properties, calculation rules and standards	178
 Tubes: Dimensions and pressure rates	
 EO-Tubes for fitting systems	
Overview EO-fitting systems.....	184
Overview EO-Steel tubes for fitting systems.....	185
Overview EO-Stainless steel tubes for fitting systems.....	187
 EO-Steel tubes	
seamless, metric, material E235+N / St.37.4 (1.0308).....	189
seamless, metric, material E355+N / St.52.4 (1.0580).....	191
 EO-Stainless steel tubes	
seamless, metric, material 316Ti (1.4571).....	192
seamless, metric, material 316L (1.4404).....	193
seamless, inch, material 316L (1.4404).....	194
 EO-Tubes for flange systems	
Overview EO-flange systems.....	196
Overview EO-Steel tubes for flange systems.....	197
Overview EO-Stainless steel tubes for flange systems.....	198
 EO-Steel tubes	
seamless, metric, material E235+N / St.37.4 (1.0308)	
• for marine- and offshore-applications.....	199
• for industrial- and mobile-applications.....	200
seamless, metric, material E355+N / St.52.4 (1.0580)	
• for marine- and offshore-applications.....	201
• for industrial- and mobile-applications.....	202
 EO-Stainless steel tubes	
seamless, metric, material 316Ti (1.4571)	
• for marine-and offshore-applications.....	203
• for industrial- and mobile-applications.....	204
seamless, metric, material 316L (1.4404)	
• for marine- and offshore-applications.....	205
• for industrial- und mobile-applications.....	206
seamless, scheduled sizes, material 316L (1.4404)	
• for marine-and offshore-applications.....	207
Conversion tables.....	208

Tubes for fluid, hydraulic and pneumatic applications

The world of tubes

Your choice for high pressure.

The tube programme from Parker Hannifin gives all possibilities for usage in hydraulic applications. Tubes for fitting- and flange-systems, tubes for mobile and stationary systems. Different dimensions, carbon- and stainless-steel tubes as well as different surfaces are available.

Approved quality.

Parker tubes are designed for the special requirements in several markets. Continuous tests in laboratories and on the benches ensure the high quality level of the material. Certifications from independent institutes such as ABS, LR, BV or DNV confirm the adherence to high standards. This opens into reliability and longevity of the hydraulic application.

Worldwide connections.

The Parker Hannifin tube-warehouse with its worldwide network provides a close and prompt supply of high precision tubes; thus, international customers can also rely on us. Efficient, reliable, environmentally friendly and on-time deliveries are available in almost every country in the world.

All around tubes.

This brochure provides all relevant information regarding hydraulic lines in a structured and clear way. Which parameters are important, what kind of tubes and dimensions fit the construction and specifications, and which materials are in use in special applications. With Parker order codes you can start right away...

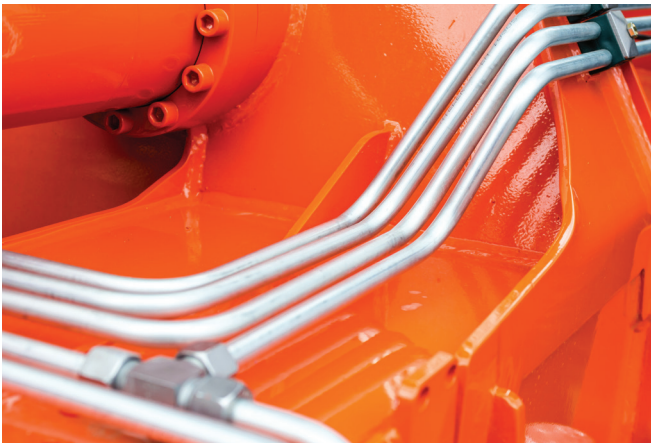

Certificates

Parker is certified acc. ISO 9001 (Quality management), ISO 14001 (Environment management) and ISO/TS 16949 (Quality management).

On request our tubes & pipes have the relevant certificates for your markets. Please ask for details.



Complete Piping Solutions and System Supplier

Added Value maximizes your performance

CPS – Complete Piping Solutions.

Just tubes! But it gets even better. Many customers like to have the complete Parker programme, and that's what we deliver worldwide based on our "Complete Piping Solutions"-concept. Technical support, reengineering, pre-fabrication, delivery and installation. These five steps give an effective and environmentally friendly solution from one source

Our integrated knowledge, quality products, contemporary production methods and installation-experience guarantee perfect complete solutions for hydraulic systems. Integration in existing systems is also available. We help our customers right from their project start to highest productivity and timeliness.

Advantages as a system supplier.

Parker Hannifin is the world's leading diversified manufacturer of motion and control technology. The company offers a product portfolio that is exemplary in the breadth and depth, and in constantly keeping quality. Through an international distribution network, the components are delivered quickly.

System solutions are tailored to the customer's situation. Whether DIN or SAE and available anywhere in the world. It will match everything together with a system, and the global design production is nothing in the way to the last detail. Efficient, sustainable and progressive.



ENGINEERING YOUR SUCCESS.

Tube and pipe specification

Recommended carbon steel tubes and pipes

Parker recommends the use of cold drawn seamless and regular annealed (abbreviation +N) hydraulic tubes and pipes acc.:

DIN-EN 10305 (old DIN 2391) and ISO 3304.

For the assembly of steel fittings, steel tubes made of material E235 (ST37.4 +N) and E355 (ST52.4 +N) are recommended.

- + precision dimension/shape
- + clean inside
- + high pressure capability
- + excellent scaling surface after roll flaring

Recommended stainless steel tubes and pipes

Parker recommends the use of seamless cold drawn stainless steel tubes and pipes acc. to:

DIN EN 10216-5, ASTM A269/A213, ASTM A312.

EO precision stainless steel tube meets and exceeds these standards. The tolerances of the pipe outer diameter and wall thickness are even closer to ensure a safe interplay with our fitting systems.

For the assembly of stainless steel tube fittings, EO precision stainless steel tubes made of material 316 Ti and 316L are recommended.

- + precision dimension/shape
- + excellent scaling surface after roll flaring
- + high pressure capability

Welded tubes and pipes

Tubes and pipes acc. to below specification but welded and cold redrawn instead of seamless drawn are usually suitable. Pressure capability might be reduced due to the welding seam zone.

Welding seam quality might effect roll flaring surface results.

Hot rolled pipes

Hot rolled pipes are not recommended for the following reasons:

Hot rolled pipes do not have precision dimensions and may slip in machine dies.

They have scales inside and outside. The inside scales effect the cleanliness level of the fluid and reduces fatigue levels. Used in roll flaring process the scales will contaminate the flaring tools (high cleaning effort) and cause poor flare surface quality.

The required maximum working pressure is calculated either acc. to DIN or DNV.

Material specifications & values

E235+N / St.37.4 (1.0308) acc. to DIN EN 10305-4

Tensile strength	min. 340 N/mm ²
Yield strength	min. 235 N/mm ²
Fatigue strength	225 N/mm ² ¹⁾
Elongation at break	min.. 25%

E355+N / St.52.4 (1.0580) acc. to DIN EN 10305-4

Tensile strength	min. 490 N/mm ²
Yield strength	min. 355 N/mm ²
Fatigue strength	265 N/mm ² ²⁾
Elongation at break	min.. 22 %

316Ti (1.4571) cold drawn (CFA) acc. to DIN EN 10216-5

316L (1.4404) cold drawn (CFA)³⁾ acc. to DIN EN 10216-5

Tensile strength	min. 500 N/mm ²
0.2 % proof stress	min. 210 N/mm ²
1 % proof stress	min. 245 N/mm ²
Fatigue strength	220 N/mm ² ²⁾
Elongation at break	min. 35 %

316L (1.4404) acc. to ASTM A269 / A213 (CFD)

316L (1.4404) acc. to ASTM A312 / A530

Tensile strength	min. 485 N/mm ²
Yield strength	min. 170 N/mm ²
0.2 % proof stress / 1.6	106 N/mm ²
Fatigue strength	220 N/mm ² ²⁾
Elongation at break	min. 35 %

Due to Parker's high quality standards, the DNV-calculation assumes higher values. (see page 182)

¹⁾ DIN 2413, 6.331

²⁾ No standard value, Experience value

³⁾ Strength increase due to cold forming following 1.4571

Tube calculation for industrial and mobile applications acc. to DIN rules

DIN 2413 I, only for static load

Calculation of working pressure of steel tubes for static stress up to 120°C. Corrosion - additional allowances are not considered for the calculation of pressures. Tubes with a diameter of OD/ID > 2 are calculated for static stress in accordance with DIN 2413 III, but with K = yield strength.

$$P = \frac{20 * K * s * c}{S * D}$$

- P = permissible working pressure [bar]
- K = yield strength [N/mm²]
- s = tube wall thickness [mm]
- c = factor for wall thickness allowance
 - = 0.8 for Tube-OD 4-5
 - = 0.85 for Tube-OD 6-8
 - = 0.9 from Tube-OD 10
 - = 0.9 for all stainless steel tubes
- S = Safety factor = 1.5
- D = tube outside diameter [mm]

DIN 2413 III, for dynamic load

Calculation of working pressure of steel tubes for dynamic stress up to 120°C. Corrosion - additional allowances are not considered for the calculation of pressures.

$$P = \frac{20 * K * s * c}{S * (D + s * c)}$$

- P = permissible working pressure [bar]
- K = fatigue strength [N/mm²]
- s = tube wall thickness [mm]
- c = factor for wall thickness allowance
 - = 0.8 for Tube-OD 4-5
 - = 0.85 for Tube-OD 6-8
 - = 0.9 for Tube-OD 10-80
 - = 0.9 for all stainless steel tubes
- S = safety factor = 1.5
- D = tube outside diameter [mm]

Burst pressure calculation

Calculation of static burst pressure for seamless tubes acc. to Faupel-von-Mises.

$$BP = R_{p0.2} * 10 \frac{2}{\sqrt{3}} \ln \frac{D}{d} * (2 - \frac{R_{p0.2}}{R_m})$$

- BP = Min. static burst pressure [bar]
- R = tensile strength [N/mm²]
- R_{p0.2} = 0.2% proof stress, yield strength [N/mm²]
- D = Tube outside diameter [mm]
- d = Tube inside diameter [mm]

Tube calculation for marine and offshore acc. to DNV rules

Calculation of working pressure of steel and stainless steel tubes for ship building acc. to DNV Part 4, Chapter 6, Section 6.

$$P = \frac{20 * \sigma_t * e * t_0}{D - t_0}$$

- P = permissible working pressure [bar]
- BP = approximate burst pressure [bar]
- σ_t = permissible stress [N/mm²]
calculated from the lower value off:

t₀ = tube wall thickness without allowances [mm]

- t_n = tube wall thickness nominal [mm]
- a = factor for wall thickness allowance
 - = 0.8 for Tube-OD 4-5, 0.85 for Tube-OD 6-8, 0.9 for Tube-OD >=10
 - = 0.875 for Schedule Pipes
 - = 0.9 for all stainless steel tubes
- b = bending allowance

- c = corrosion tolerance, c = 0.3 mm for hydraulic steel tube, c = 0 mm for SS tubes
- e = strength ratio: for seamless tubes e = 1
- D = tube outside diameter [mm]
- R_m = min. tensile strength [N/mm²]
- K = min. yield strength or min 0.2% proof stress [N/mm²]

Calculation of burst pressure:

$$BP = \frac{20 * R_m * t_n * a}{D - t_n * a}$$

- | | |
|---|---|
| stainless steel: | carbon steel: |
| σ _t = $\frac{R_m}{2.7}$ or $\frac{K}{1.6}$ | σ _t = $\frac{R_m}{2.7}$ or $\frac{K}{1.8}$ |

$$t_0 = t_n * a - c - b$$

$$b = \frac{1}{2.5} * \frac{D}{R} * t_0$$

$$b = 0.1333 * t_0 \text{ (at } R/D=3) \rightarrow t_0 = \frac{t_n * a - c}{1.1333}$$

Pressure reductions and temperatures

Required pressure reductions (depending on the material) with reference to the catalogue pressures for higher temperatures. Both metal fitting material and elastomeric sealing compound have to be selected according to the temperature range of the system.

DNV may require different pressure reduction based on application

Material	Pressure reduction of permissible operating temperatures TB in °C														
	-60	-50	-40	-35	-25	+20	+50	+100	+120	+150	+175	+200	+250	+300	+400
Steel fittings						0%				11%	19%	28%			
Steel flange-systems			10%				0%			11%	19%				
Steel, tubes						0%					19%		27%		
Stainless steel fittings						0%					19%		27%		
Stainless steel flange-systems			0%				5%	15%	23%		29%	33%	37%	42%	
Stainless steel, tubes			0%				5,5%	11,5%		21,5%			29%	34%	
Sealing material NBR (e.g. Perbunan)															
Sealing material FKM															
Sealing material Polyurethan (P5008)															

	Permissible
	Ambient temperature of hydraulic and pneumatic applications
	Temperature not permissible

Calculation example:
 Temperature = 200°C
 Material = Stainless steel
 Pressure reduction = 29%
 Pressure reduction tubes = 21.5%
 PN tube 16x2.5/71. DIN2413 III = 362 bar

Formula:

$$PN_{200^{\circ}\text{C}} = \frac{400 \text{ bar}}{100\%} \times (100\% - 29\%) = 284 \text{ bar}$$

$$PN_{\text{tube } 200^{\circ}\text{C}} = \frac{362 \text{ bar}}{100\%} \times (100\% - 21.5\%) = 284 \text{ bar}$$

Flow diameter of tube lines

Determining tube sizes for hydraulic systems

Proper tube material, type and size for a given application and type of fitting are critical for efficient and trouble-free operation of the fluid system. Selection of proper tubing involves choosing the right tube material, and determining the optimum tube size (O.D. and wall thickness).

Proper sizing of the tube for various parts of a hydraulic system results in an optimum combination of efficient and cost effective performance.

A tube that is too small causes high fluid velocity, which has many detrimental effects. In pressure lines, it causes high friction losses and turbulence, both resulting in high pressure drops and heat generation. High heat accelerates wear in moving parts and rapid aging of seals and hoses, all resulting in reduced component life. High heat generation also means wasted energy, and hence, low efficiency. Too large tubes increase system cost. Thus, optimum tube sizing is very critical. The following is a simple procedure for sizing tubes.

Determine required flow diameter

Use table to determine recommended flow diameter for the required flow rate and type of line.

The table is based on the following recommended flow rates that are common in the shipbuilding and offshore engineering.

Pressure lines	- 3	→ 7.2	$\left[\frac{\text{m}}{\text{s}} \right]$
Return lines	- 2	→ 4.5	$\left[\frac{\text{m}}{\text{s}} \right]$
Suction lines	- 1	→ 1.8	$\left[\frac{\text{m}}{\text{s}} \right]$

Avoid flow rates > 8 m/s!

The resulting forces are high and can destroy the tube lines.

If you desire to use different velocities than the above, use the following formula to determine the required flow diameter.

$$\text{Tube - I.D. [mm]} = 4,61 \times \sqrt{\frac{\text{Flow} \left[\frac{\text{ltr.}}{\text{min}} \right]}{\text{Velocity} \left[\frac{\text{m}}{\text{s}} \right]}}$$

Determine required wall thickness

Use tube/pressure calculation tables shown in the tube chapter to determine recommended wall thickness for the required working pressure and flow diameter of the line.

Therefore choose a working pressure which is equal or higher than the required working pressure.



Flow characteristics

Hydraulic systems are in most cases only rated with a flow velocity defined on the basis of experience. The pressure losses in lines are not taken into account, or measured later on when testing the system. As the pressure losses increase proportionally greater than the flow resistance, it is important to achieve the best rating of the system, so that they are already taken into account when planning the tube connections. Calculation is not as difficult as it is often thought, and this chapter is intended to provide a guideline. Besides, it provides information on how excessive pressure losses can be avoided, because pressure losses result in losses in performance and excessive heat. Noise occurs and possibly cavitation in suction lines.

Medium

All indication given with regard to flow restrictions and to flow properties refer exclusively to liquids. For gaseous media, the variable density of the gas must additionally be taken into account.

Units

c = Flow velocity $\left[\frac{\text{m}}{\text{s}}\right]$

d = Pipe inside diameter [m]

L = Pipe length [m]

ρ = Pressure [Pa], 1 bar = 100000 Pa

\dot{V} = Flow rate $\left[\frac{\text{m}^3}{\text{s}}\right]$, $1 \frac{\text{m}^3}{\text{s}} = 60000 \frac{\text{l}}{\text{min}}$

λ = Pipe friction factor

$\nu(T)$ = Kinematic viscosity of the medium depending on temperature $\left[\frac{\text{m}^2}{\text{s}}\right]$

$\rho(T)$ = Density of the medium depending on temperature $\left[\frac{\text{kg}}{\text{m}^3}\right]$

ζ = Individual pressure loss coefficient

Only base units have been used. This has the advantage that the formula do not contain correction factors and there is no danger of confusion, e.g. that values are used with the wrong unit. In case values are given in other units - the flow rate is e.g. often given in l/min - it is advisable to convert them into the base units before starting calculation.

Pressure losses in pipe lines

To calculate pressure losses in pipe lines, it must first be determined whether there is a laminar or a turbulent flow. Laminar flow is homogenous and without turbulence. In case of turbulent flow, the losses increase much more quickly.

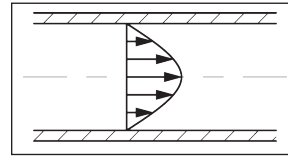

Flow profile with laminar flow

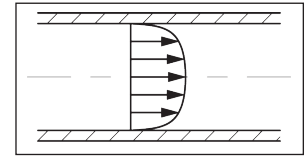

Flow profile with turbulent flow

The kind of flow is defined by the Reynolds' number. With a Reynolds' number of more than 2320, the flow changes to turbulent. The Reynolds' number is calculated according to the formula:

$$Re = \frac{c \cdot d}{\nu(T)}$$

The Reynolds' number is a non-dimensional number. The critical fluid velocity at which the flow regime can change, is thus calculated from:

$$c_{cr} = 2320 \cdot \frac{\nu(T)}{d} \left[\frac{\text{m}}{\text{s}}\right]$$

With a given flow rate, the fluid velocity can be calculated according to the formula:

$$c = \frac{\dot{V} \cdot 4}{d^2 \cdot \pi} \left[\frac{\text{m}}{\text{s}}\right]$$

Subsequently, the pipe friction factor λ can be calculated. The pipe friction factor λ is a function of the Reynolds' number and also depends on the roughness of the pipe. As hydraulically smooth pipes can generally be assumed in hydraulic applications, the pipe friction factor λ is calculated according to the following formula:

$$\text{laminar flow, (} Re < 2320\text{): } \lambda = \frac{64}{Re}$$

$$\text{turbulent flow, (} Re > 2320\text{): } \lambda = \frac{0.3164}{\sqrt[4]{Re}}$$

Finally, if all factors are known, the pressure loss in a certain pipe line can be calculated according to the formula:

$$\Delta p = \lambda \cdot \frac{L}{d} \cdot \frac{\rho(T) \cdot c^2}{2} \text{ [Pa]}$$

Calculation of individual losses

A hydraulic system does not only incorporate pipes, but also valves, fittings, pipe bends etc. that cause flow losses. These individual losses are often much higher than the pipe losses and are calculated according to the following formula:

$$\Delta p = \zeta \cdot \rho(T) \cdot \frac{c^2}{2} \text{ [Pa]}$$

Material specifications & values for DNV-calculation

Due to Parker's high quality standards, the DNV-calculation assumes higher values for tensile strength and yield strength. These values are experience values. Nominal pressure calculation based on these mechanical properties requires a certification in accordance with 3.1 - EN 10204, which confirms the mechanical properties.

E235+N / St.37.4 (1.0308) acc. to DIN EN 10305-4

Tensile strength	390 N/mm ²
Yield strength	min 235 N/mm ²
Proof stress (Yield strength / 1.8)	130.5 N/mm ²

E355+N / St.52.4 (1.0580) acc. to DIN EN 10305-4

Tensile strength	533 N/mm ²
Yield strength	min 355 N/mm ²
Proof stress (Yield strength / 1.8)	197 N/mm ²

316Ti (1.4571) cold drawn (CFA) acc. to DIN EN 10216-5

316L (1.4404) cold drawn (CFA)¹⁾ acc. to DIN EN 10216-5

316L (1.4404) acc. to ASTM A269 / A213 (CFD)

Tensile strength	530 N/mm ²
Yield strength	min 276 N/mm ²
Proof stress (0,2 % Yield strength / 1.6)	172.5 N/mm ²

316L (1.4404) acc. to ASTM A312 / A530

Tensile strength	515 N/mm ²
Yield strength	min 234 N/mm ²
Proof stress (0,2 % Yield strength / 1,6)	146 N/mm ²

¹⁾ Strength increase due to cold forming following 1.4571

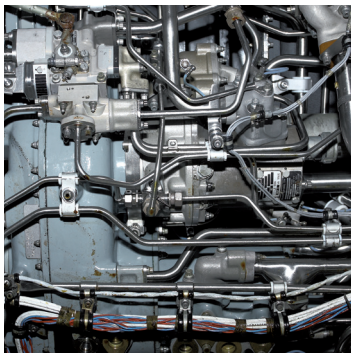

E0-Tubes for fitting systems

Industrial- and Mobile-Applications

Overview EO-Fitting systems

EO-PSR/DPR

Fitting system with progressive stop ring



The advantages

- Special design of the PSR ring with 2 cutting edges for safe, fast and easy assembly
- Special design of the PSR-ring with noticeable end point of assembly by stop contour
- Spring effect compensates subsidences of tube bite and threads - no retightening necessary

As the inventor of the cutting ring (patent of 1934), Parker is looking back on a long history of this milliontimes proven system.

EO-2®

Fitting system with elastomeric seal



The advantages

- Permanently reliable function due to the leak-free elastomeric seal
- Optimized installation space - Prevention of gap extrusion / abrasion
- Protection of over-/underassembly, due to the "Hit-home-feel"
- Clear assembly result by visual pre-assembly inspection

The common feature of all EO-2 fittings is elastomeric seals on all joints. These are also available in FKM for applications with higher temperatures or aggressive media.

EO2-FORM

High pressure formed tube fitting



The advantages

- Absolutely tear-out proof and thus very reliable function
- Significant time and cost savings compared to welding
- Maximum system performance with minimum component, assembly and storage costs

EO2-FORM is based on the EO-2 product family and is therefore an optimal system solution for all hydraulic applications.

O-Lok®

Tube fitting with O-ring face seal



The advantages

- Reliable function and leak-free operation, due to the specially protected O-ring seal
- Higher lifetime and improved corrosion resistant surface
- Easy assembly due to reduced assembly-torques

O-Lok® fittings consist of a nut, a body, an O-ring and a sleeve. The tube is flanged to 90° using the Parflange® system.

Triple-Lok®

Versatile 37°-flare fitting



The advantages

- Wide range of application due to increased nominal pressures
- Sealing surface is protected separately during transport
- More constructive possibilities through the most comprehensive standard programme.

Triple-Lok® fittings convince due to the simple, reliable design, compact design, easy assembly and worldwide availability.

Overview EO steel tubes for fitting systems

Material E235+N / St.37.4 (1.0308)		Material E355+N / St.52.4 (1.0580)		Fitting systems			
				DPR PSR EO-2	EO2 FORM	O-Lok®	Triple- Lok®
Surface Phosphated and oiled	Surface Cr(VI)-free	Surface Phosphated and oiled	Surface Cr(VI)-free				
Order code		Order code					
R04X0.5	R04X0.5CF			X	-	-	-
	R04X0.75CF			X	-	-	-
R04X1	R04X1CF			X	-	-	-
	R05X1CF			X	-	-	-
	R06X0.75CF			X	-	-	-
R06X1	R06X1CF			X	X	X	X
R06X1.5	R06X1.5CF			X	X	X	X
	R06X2CF			X	X	-	-
R06X2.25	R06X2.25CF			X	-	-	-
R08X1	R08X1CF			X	X	X	X
R08X1.5	R08X1.5CF			X	X	X	X
R08X2	R08X2CF			X	X	X	-
	R08X2.5CF			X	X	-	-
R10X1	R10X1CF			X	X	X	X
R10X1.5	R10X1.5CF			X	X	X	X
R10X2	R10X2CF		R10X2ST52CF	X	X	X	-
R10X2.5	R10X2.5CF			X	-	-	-
	R10X3CF			X	X	-	-
R12X1	R12X1CF			X	X	X	X
R12X1.5	R12X1.5CF		R12X1.5ST52CF	X	X	X	X
R12X2	R12X2CF		R12X2ST52CF	X	X	X	X
	R12X2.5CF			X	X	-	-
	R12X3CF			X	X	-	-
	R12X3.5CF			X	-	-	-
	R14X1.5CF			X	-	-	-
R14X2	R14X2CF			X	-	-	-
R14X2.5	R14X2.5CF			X	-	-	-
	R14X3CF			X	-	-	-
R15X1	R15X1CF			X	X	X	X
R15X1.5	R15X1.5CF		R15X1.5ST52CF	X	X	X	X
R15X2	R15X2CF		R15X2ST52CF	X	X	X	X
R16X1.5	R16X1.5CF		R16X1.5ST52CF	X	-	X	X
R16X2	R16X2CF	R16X2ST52	R16X2ST52CF	X	X	X	X
R16X2.5	R16X2.5CF		R16X2.5ST52CF	X	X	X	X
R16X3	R16X3CF			X	X	X	-
R18X1	R18X1CF			X	-	-	-
R18X1.5	R18X1.5CF		R18X1.5ST52CF	X	X	X	X
R18X2	R18X2CF		R18X2ST52CF	X	X	X	X
R18X2.5	R18X2.5CF			X	-	-	X
	R18X3CF			X	-	-	X
	R20X1.5CF			X	-	-	-
R20X2	R20X2CF		R20X2ST52CF	X	X	X	X
R20X2.5	R20X2.5CF		R20X2.5ST52CF	X	X	X	X
R20X3	R20X3CF		R20X3ST52CF	X	X	X	X
	R20X3.5CF			X	X	-	-
	R20X4CF			X	-	-	-
R22X1.5	R22X1.5CF		R22X1.5ST52CF	X	X	X	X
R22X2	R22X2CF		R22X2ST52CF	X	X	X	X
R22X2.5	R22X2.5CF			X	X	X	X
	R22X3CF			X	-	-	X
R25X2	R25X2CF			X	X	X	X
R25X2.5	R25X2.5CF		R25X2.5ST52CF	X	X	X	X
R25X3	R25X3CF	R25X3ST52	R25X3ST52CF	X	X	X	X
R25X4	R25X4CF		R25X4ST52CF	X	X	X	-
	R25X4.5CF			X	-	-	-
R28X1.5	R28X1.5CF			X	-	X	X
R28X2	R28X2CF		R28X2ST52CF	X	X	X	X
R28X2.5	R28X2.5CF			X	X	X	X
R28X3	R28X3CF			X	-	X	X

EO-Tubes for fitting systems (Industrial- and Mobile-Applications)

Overview EO steel tubes for fitting systems

Material				Fitting systems			
E235+N / St.37.4 (1.0308)		E355+N / St.52.4 (1.0580)		PSR EO-2	EO2- FORM	O-Lok®	Triple- Lok®
Surface		Surface					
Phosphated and oiled	Cr(VI)-free	Phosphated and oiled	Cr(VI)-free				
Order code		Order code					
	R30X2CF			X	-	X	X
R30X2.5	R30X2.5CF			X	-	X	X
R30X3	R30X3CF	R30X3ST52	R30X3ST52CF	X	X	X	X
R30X4	R30X4CF		R30X4ST52CF	X	X	X	-
R30X5	R30X5CF		R30X5ST52CF	X	X	-	-
R35X2	R35X2CF			X	X	X	X
R35X2.5	R35X2.5CF			X	-	X	X
R35X3	R35X3CF		R35X3ST52CF	X	X	X	X
	R35X4CF			X	-	-	-
	R38X2.5CF			X	-	X	X
R38X3	R38X3CF		R38X3ST52CF	X	X	X	X
R38X4	R38X4CF	R38X4ST52	R38X4ST52CF	X	X	X	X
R38X5	R38X5CF		R38X5ST52CF	X	X	X	-
	R38X6CF		R38X6ST52CF	X	X	-	-
	R38X7CF			X	X	-	-
R42X2	R42X2CF			X	X	-	X
R42X3	R42X3CF		R42X3ST52CF	X	X	-	X
R42X4	R42X4CF		R42X4ST52CF	X	X	-	-
			R42X5ST52CF	X	-	-	-

Other sizes on request!



Overview EO stainless steel tubes for fitting systems

316Ti (1.4571)	Material		Fitting systems			
	316L (1.4404)		DPR EO-2	EO2- FORM	O-Lok®	Triple- Lok®
	bright annealed	Surface pickled				
Order code						
R04X171		R04X1-316BA	(X)	-	-	-
R06X171		R06X1-316BA	X	X	X	X
R06X1.571		R06X1.5-316BA	X	X	X	X
R08X171		R08X1-316BA	X	X	X	X
R08X1.571			X	X	X	X
R10X171		R10X1-316BA	X	X	X	X
R10X1.571		R10X1.5-316BA	X	X	X	X
R10X271		R10X2-316BA	X	X	X	-
R12X171		R12X1-316BA	X	X	X	X
R12X1.571		R12X1.5-316BA	X	X	X	X
R12X271		R12X2-316BA	X	X	X	X
R14X1.571			X	-	-	-
R14X271			X	-	-	-
R14X2.571			X	-	-	-
R15X171			X	X	X	X
R15X1.571		R15X1.5-316BA	X	X	X	X
R15X271			X	X	X	X
R16X1.571			X	-	X	X
R16X271	R16X2-316		X	X	X	X
R16X2.571	R16X2.5-316		X	X	X	X
R16X371			X	X	X	-
R18X1.571	R18X1.5-316		X	X	X	X
R18X271	R18X2-316		X	X	X	X
R20X271	R20X2-316		X	X	X	X
R20X2.571	R20X2.5-316		X	X	X	X
R20X371			X	X	X	X
R22X1.571			X	X	X	X
R22X271	R22X2-316		X	X	X	X
R25X271	R25X2-316		X	X	X	X
R25X2.571	R25X2.5-316		X	X	X	X
R25X371	R25X3-316		X	X	X	X
R28X1.571			X	-	X	X
R28X271	R28X2-316		X	X	X	X
R28X2.571			X	X	X	X
R30X2.571	R30X2.5-316		X	-	X	X
R30X371	R30X3-316		X	X	X	X
R30X471			X	X	X	-
R35X271			X	X	X	X
R35X2.571			X	-	X	X
R35X371	R35X3-316		X	X	X	X
R38X2.571			X	-	X	X
	R38X3-316		-	X	X	X
R38X471	R38X4-316		X	X	X	X
	R38X5-316		X	X	X	-
	R38X6-316		X	X	-	-
R42X271			X	X	-	X
R42X371	R42X3-316		X	X	-	X

(x) DPR available, EO-2 not available

Other sizes on request!

EO-Tubes for fitting systems (Industrial- and Mobile-Applications)

Overview EO stainless steel tubes for fitting systems

Material 316L (1.4404)	Fitting systems			
	DPR EO-2	EO2- FORM	O-Lok®	Triple- Lok®
	Surface bright annealed			
Order code				
R1/8X0.028TP316/I	-	-	on request	on request
R5/16X0.035TP316/L	-	-	on request	on request
R1/4X0.035TP316/L	-	-	on request	on request
R1/4X0.049TP316/L	-	-	on request	on request
R1/4X0.065TP316/L	-	-	on request	on request
R3/8X0.035TP316/L	-	-	on request	on request
R3/8X0.049TP316/L	-	-	on request	on request
R3/8X0.065TP316/L	-	-	on request	on request
R1/2X0.035TP316/L	-	-	on request	on request
R1/2X0.049TP316/L	-	-	on request	on request
R1/2X0.065TP316/L	-	-	on request	on request
R1/2X0.083TP316/L	-	-	on request	on request
R5/8X0.049TP316/L	-	-	on request	on request
R5/8X0.065TP316/L	-	-	on request	on request
R3/4X0.049TP316/L	-	-	on request	on request
R3/4X0.065TP316/L	-	-	on request	on request
R3/4X0.083TP316/L	-	-	on request	on request
R3/4X0.095TP316/L	-	-	on request	on request
R3/4X0.109TP316/L	-	-	on request	on request
R1X0.065TP316/L	-	-	on request	on request
R1X0.083TP316/L	-	-	on request	on request
R1X0.095TP316/L	-	-	on request	on request
R1X0.126TP316/L	-	-	on request	-

Other sizes on request!



Seamless EO steel tubes | Material E235+N / St.37.4 (1.0308)

Acc. to DIN EN 10305-4

- DIN 2413 I: Tubes with a diameter of OD/ID>2 are calculated for static stress in accordance with DIN 2413 III but with K=yield strength.
- Evaluated in Parker Lab and Test Field. () = Burst pressure (B.P.) acc. to Faupel-von-Mises

Material E235+N / St.37.4 (1.0308)		d _a Outer-Ø (mm)	Outer-Ø Tolerance (mm)	s Wall- thickness (mm)	d _i Inner-Ø (mm)	Design pressure		2 Burst pressure bar	Weight kg/m
Surface						1 DIN 2413 I static PN bar	DIN 2413 III dynamic PN bar		
Phosphated and oiled	Cr(VI)- free	Order code							
R04X0.5	R04X0.5CF	04		0.50	3.0	313	273	1160	0.047
	R04X0.75CF	04	±0.08	0.75	2.5	470	391	1820	0.063
R04X1	R04X1CF	04		1.00	2.0	627	500	2700	0.074
	R05X1CF	05	±0.08	1.00	3.0	501	414	2120	0.099
	R06X0.75CF	06		0.75	4.5	333	288	1150	0.103
R06X1	R06X1CF	06		1.00	4.0	444	372	1650	0.123
R06X1.5	R06X1.5CF	06	±0.08	1.50	3.0	666	526	2550	0.166
	R06X2CF	06		2.00	2.0	692	662	>3500	0.197
R06X2.25	R06X2.25CF	06		2.25	1.5	757	725	>3500	0.208
R08X1	R08X1CF	08		1.00	6.0	333	288	1175	0.173
R08X1.5	R08X1.5CF	08	±0.08	1.50	5.0	499	412	1925	0.240
R08X2	R08X2CF	08		2.00	4.0	666	526	2500	0.296
	R08X2.5CF	08		2.50	3.0	658	630	2650	0.339
R10X1	R10X1CF	10		1.00	8.0	282	248	900	0.222
R10X1.5	R10X1.5CF	10		1.50	7.0	423	357	1450	0.314
R10X2	R10X2CF	10	±0.08	2.00	6.0	564	458	2025	0.395
R10X2.5	R10X2.5CF	10		2.50	5.0	705	551	2675	0.462
	R10X3CF	10		3.00	4.0	666	638	>3500	0.518
R12X1	R12X1CF	12		1.00	10.0	235	209	750	0.271
R12X1.5	R12X1.5CF	12		1.50	9.0	353	303	1150	0.388
R12X2	R12X2CF	12	±0.08	2.00	8.0	470	391	1600	0.493
	R12X2.5CF	12		2.50	7.0	588	474	2025	0.586
	R12X3CF	12		3.00	6.0	705	551	2600	0.666
	R12X3.5CF	12		3.50	5.0	651	624	(3109)	0.734
	R14X1.5CF	14		1.50	11.0	302	264	975	0.462
R14X2	R14X2CF	14	±0.08	2.00	10.0	403	342	1325	0.592
R14X2.5	R14X2.5CF	14		2.50	9.0	504	415	1650	0.709
	R14X3CF	14		3.00	8.0	604	485	2200	0.814
R15X1	R15X1CF	15		1.00	13.0	188	170	575	0.345
R15X1.5	R15X1.5CF	15	±0.08	1.50	12.0	282	248	950	0.499
R15X2	R15X2CF	15		2.00	11.0	376	321	1275	0.641
R16X1.5	R16X1.5CF	16		1.50	13.0	264	233	850	0.536
R16X2	R16X2CF	16	±0.08	2.00	12.0	353	303	1175	0.691
R16X2.5	R16X2.5CF	16		2.50	11.0	441	370	1500	0.832
R16X3	R16X3CF	16		3.00	10.0	529	433	1850	0.962
R18X1	R18X1CF	18		1.00	16.0	157	143	450	0.419
R18X1.5	R18X1.5CF	18		1.50	15.0	235	209	700	0.610
R18X2	R18X2CF	18	±0.08	2.00	14.0	313	273	975	0.789
R18X2.5	R18X2.5CF	18		2.50	13.0	392	333	1300	0.956
	R18X3CF	18		3.00	12.0	470	391	1575	1.111

Surface finish:

- Tubes with I.D. 1.5-5 mm: outside and inside oiled.
- Tubes from 6 mm I.D.: outside and inside phosphated and oiled.

• Cr(VI)-free:

These dimensions are externally thick coat passivated (thickness of coat 8-12µm), inside oiled.

EO-Tubes for fitting systems (Industrial- and Mobile-Applications)

Seamless EO steel tubes (continued) | Material E235+N / St.37.4 (1.0308)

Acc. to DIN EN 10305-4

1. DIN 2413 I: Tubes with a diameter of OD/ID>2 are calculated for static stress in accordance with DIN 2413 III but with K=yield strength.
2. Evaluated in Parker Lab and Test Field.

Material E235+N / St.37.4 (1.0308)		d _a Outer-Ø (mm)	Outer-Ø Tolerance (mm)	s Wall- thickness (mm)	d _i Inner-Ø (mm)	Design pressure		2 Burst pressure bar	Weight kg/m
Surface						1 DIN 2413 I static PN bar	DIN 2413 III dynamic PN bar		
Phosphated and oiled	Cr(VI)- free	Order code							
R20X2	R20X1.5CF	20	±0.08	1.50	17.0	212	190	675	0.684
	R20X2CF	20		2.00	16.0	282	248	900	0.888
R20X2.5	R20X2.5CF	20		2.50	15.0	353	303	1100	1.079
R20X3	R20X3CF	20		3.00	14.0	423	357	1400	1.258
	R20X3.5CF	20		3.50	13.0	494	408	1650	1.424
	R20X4CF	20		4.00	12.0	564	458	2000	1.578
R22X1.5	R22X1.5CF	22	±0.08	1.50	19.0	192	173	550	0.758
R22X2	R22X2CF	22		2.00	18.0	256	227	775	0.986
R22X2.5	R22X2.5CF	22		2.50	17.0	320	278	1025	1.202
	R22X3CF	22		3.00	16.0	385	328	1175	1.406
R25X2	R25X2CF	25	±0.08	2.00	21.0	226	201	725	1.134
R25X2.5	R25X2.5CF	25		2.50	20.0	282	248	850	1.387
R25X3	R25X3CF	25		3.00	19.0	338	292	1025	1.628
R25X4	R25X4CF	25		4.00	17.0	451	378	1500	2.072
	R25X4.5CF	25	4.50	16.0	508	418	1625	2.275	
R28X1.5	R28X1.5CF	28	±0.08	1.50	25.0	151	138	425	0.980
R28X2	R28X2CF	28		2.00	24.0	201	181	600	1.282
R28X2.5	R28X2.5CF	28		2.50	23.0	252	223	750	1.572
R28X3	R28X3CF	28		3.00	22.0	302	264	900	1.850
R30X2.5	R30X2CF	30	±0.08	2.00	26.0	188	170	575	1.381
	R30X2.5CF	30		2.50	25.0	235	209	725	1.695
R30X3	R30X3CF	30		3.00	24.0	282	248	850	1.998
R30X4	R30X4CF	30		4.00	22.0	376	321	1175	2.565
R30X5	R30X5CF	30		5.00	20.0	470	391	1600	3.083
R35X2	R35X2CF	35	±0.15	2.00	31.0	161	147	450	1.628
R35X2.5	R35X2.5CF	35		2.50	30.0	201	181	600	2.004
R35X3	R35X3CF	35		3.00	29.0	242	215	700	2.367
	R35X4CF	35		4.00	27.0	322	280	960	3.058
R38X3	R38X2.5CF	38	±0.15	2.50	33.0	186	168	550	2.189
	R38X3CF	38		3.00	32.0	223	199	675	2.589
R38X4	R38X4CF	38		4.00	30.0	297	260	900	3.354
R38X5	R38X5CF	38		5.00	28.0	371	318	1150	4.069
	R38X6CF	38		6.00	26.0	445	373	1425	4.735
	R38X7CF	38		7.00	24.0	519	427	1700	5.352
R42X2	R42X2CF	42	±0.20	2.00	38.0	134	123	375	1.973
R42X3	R42X3CF	42		3.00	36.0	201	181	575	2.885
R42X4	R42X4CF	42		4.00	34.0	269	237	850	3.749

Other sizes on request!



Seamless EO steel tubes | Material E355+N / St.52.4 (1.0580)

Acc. to DIN EN 10305-4

1. DIN 2413 I: Tubes with a diameter of OD/ID>2 are calculated for static stress in accordance with DIN 2413 III but with K=yield strength.
2. Burst pressure (B.P.) acc. to Faupel-von-Mises

Material E355+N / St.52.4 (1.0580)		d _a Outer-Ø (mm)	Outer-Ø Tolerance (mm)	s Wall- thickness (mm)	d _i Inner-Ø (mm)	Design pressure		2 Burst pressure bar	Weight kg/m
Surface Phosphated and oiled	Cr(VI)- free					1 DIN 2413 I static PN bar	DIN 2413 III dynamic PN bar		
Order code									
	R10X2ST52CF	10	±0.08	2.00	6.0	852	539	2671	0.395
	R12X1.5ST52CF	12		1.50	9.0	533	357	1504	0.388
	R12X2ST52CF	12	±0.08	2.00	8.0	710	461	2120	0.493
	R15X1.5ST52CF	15		1.50	12.0	426	292	1167	0.499
	R15X2ST52CF	15	±0.08	2.00	11.0	568	379	1622	0.641
R16X2ST52	R16X1.5ST52CF	16		1.50	13.0	399	275	1086	0.536
	R16X2ST52CF	16	±0.08	2.00	12.0	533	357	1504	0.691
	R16X2.5ST52CF	16		2.50	11.0	666	436	1959	0.832
	R18X1.5ST52CF	18		1.50	15.0	355	247	953	0.610
	R18X2ST52CF	18	±0.08	2.00	14.0	473	321	1314	0.789
	R20X2ST52CF	20		2.00	16.0	426	292	1167	0.888
	R20X2.5ST52CF	20	±0.08	2.50	15.0	533	357	1504	1.079
	R20X3ST52CF	20		3.00	14.0	639	420	185	1.258
	R22X1.5ST52CF	22		1.50	19.0	290	204	767	0.758
	R22X2ST52CF	22	±0.08	2.00	18.0	387	267	1049	0.986
R25X3ST52	R25X2.5ST52CF	25		2.50	20.0	426	292	1167	1.387
	R25X3ST52CF	25	±0.08	3.00	19.0	511	344	1435	1.628
	R25X4ST52CF	25		4.00	17.0	682	445	2016	2.072
	R28X2ST52CF	28	±0.08	2.00	24.0	304	213	806	1.282
R30X3ST52	R30X3ST52CF	30		3.00	24.0	426	292	1167	1.998
	R30X4ST52CF	30	±0.08	4.00	22.0	568	379	1622	2.565
	R30X5ST52CF	30		5.00	20.0	710	461	2120	3.083
	R35X3ST52CF	35	±0.15	3.00	29.0	365	253	983	2.367
R38X4ST52	R38X3ST52CF	38		3.00	32.0	336	234	899	2.589
	R38X4ST52CF	38	±0.15	4.00	30.0	448	306	1236	3.354
	R38X5ST52CF	38		5.00	28.0	561	374	1597	4.069
	R38X6ST52CF	38		6.00	26.0	673	440	1984	4.735
	R42X3ST52CF	42		3.00	36.0	304	213	806	2.885
	R42X4ST52CF	42	±0.20	4.00	34.0	406	279	1105	3.748
	R42X5ST52CF	42		5.00	32.0	507	342	1422	4.562

Surface finish:

- Tubes with I.D. 1.5-5 mm: outside and inside oiled.
- Tubes from 6 mm I.D.: outside and inside phosphated and oiled.

• Cr(VI)-free:

These dimensions are externally thick coat passivated (thickness of coat 8-12µm), inside oiled.

Other sizes on request!

EO-Tubes for fitting systems (Industrial- and Mobile-Applications)

Seamless EO stainless steel tubes | Material 316Ti (1.4571)

Acc. to DIN EN 10216-5, DIN EN 10305-1

1. DIN 2413 I: Tubes with a diameter of OD/ID>2 are calculated for static stress in accordance with DIN 2413 III but with K=yield strength.
2. Evaluated in Parker Lab and Test Field. () = Burst pressure (B.P.) acc. to Faupel-von-Mises

Material 316Ti (1.4571)	d _a Outer-Ø (mm)	Outer-Ø Tolerance (mm)	s Wall- thickness (mm)	d _i Inner-Ø (mm)	Design pressure		2 Burst pressure bar	Weight kg/m
					1	DIN 2413 III		
					DIN 2413 I static PN bar	dynamic PN bar		
R04X171	04	±0.08	1.0	2.0	735	539	(2961)	0.075
R06X171	06		1.0	4.0	490	383	1850	0.125
R06X1.571	06	±0.08	1.5	3.0	735	539	2900	0.169
R08X171	08		1.0	6.0	368	297	1300	0.175
R08X1.571	08	±0.08	1.5	5.0	551	424	2050	0.244
R10X171	10		1.0	8.0	294	242	950	0.225
R10X1.571	10	±0.08	1.5	7.0	441	349	1750	0.319
R10X271	10		2.0	6.0	588	447	2400	0.401
R12X171	12		1.0	10.0	245	205	850	0.275
R12X1.571	12	±0.08	1.5	9.0	368	297	1400	0.394
R12X271	12		2.0	8.0	490	383	1900	0.501
R14X1.571	14		1.5	11.0	315	258	1200	0.469
R14X271	14	±0.08	2.0	10.0	420	334	1550	0.601
R14X2.571	14		2.5	9.0	525	406	2100	0.720
R15X171	15		1.0	13.0	196	166	675	0.351
R15X1.571	15	±0.08	1.5	12.0	294	242	1100	0.507
R15X271	15		2.0	11.0	392	314	1400	0.651
R16X1.571	16		1.5	13.0	276	228	950	0.545
R16X271	16	±0.08	2.0	12.0	368	297	1300	0.701
R16X2.571	16		2.5	11.0	459	362	1850	0.845
R16X371	16		3.0	10.0	551	424	2400	0.977
R18X1.571	18		1.5	15.0	245	205	800	0.620
R18X271	18	±0.08	2.0	14.0	327	267	1150	0.801
R20X271	20		2.0	16.0	294	242	1050	0.901
R20X2.571	20	±0.08	2.5	15.0	368	297	1400	1.095
R20X371	20		3.0	14.0	441	349	1800	1.277
R22X1.571	22		1.5	19.0	200	170	650	0.770
R22X271	22	±0.08	2.0	18.0	267	222	900	1.002
R25X271	25		2.0	21.0	235	197	763	1.152
R25X2.571	25	±0.08	2.5	20.0	294	242	1050	1.408
R25X371	25		3.0	19.0	353	286	1275	1.653
R28X1.571	28		1.5	25.0	158	135	550	0.995
R28X271	28	±0.08	2.0	24.0	210	177	700	1.302
R28X2.571	28		2.5	23.0	263	218	(840)	1.596
R30X2.571	30		2.5	25.0	245	205	850	1.722
R30X371	30	±0.08	3.0	24.0	294	242	1150	2.028
R30X471	30		4.0	22.0	392	314	1500	2.605
R35X271	35		2.0	31.0	168	143	550	1.653
R35X2.571	35	±0.15	2.5	30.0	210	177	(659)	2.035
R35X371	35		3.0	29.0	252	210	(803)	2.404
R38X2.571	38		2.5	33.0	193	164	628	2.222
R38X471	38	±0.15	4.0	30.0	309	254	1150	3.405
R42X271	42		2.0	38.0	140	121	475	2.003
R42X371	42	±0.20	3.0	36.0	210	177	750	2.930

Other sizes on request!



Seamless EO stainless steel tubes | Material 316L (1.4404)

Acc. to DIN 10216-5, DIN 10305-1 (-316BA); ASTM A269/A213 (-316)

- Due to Parker's high quality standards, the pickled tubes (-316) are calculated according to the values of bright annealed tubes (-316BA). Nominal pressure calculation based on these mechanical properties requires certification in accordance with 3.1 - EN 10204, which confirms the mechanical properties
- DIN 2413 I static pressure (W.P.) capability for straight pipe including manufacturing tolerance.
- Burst pressure (B.P.) acc. to Faupel-von-Mises

Material 316L (1.4404)		Outer-Ø Tolerance (mm)	s Wall- thickness (mm)	di Inner-Ø (mm)	Design pressure		3 Burst pressure bar	Weight kg/m
Surface					2 DIN 2413 I static PN bar	DIN 2413 III dynamic PN bar		
1 pickled	bright annealed							
Order code								
	R04X1-316BA	±0.08	1.0	2.0	735	539	2961	0.075
	R06X1-316BA	±0.08	1.0	4.0	490	383	1732	0.125
	R06X1.5-316BA		1.5	3.0	735	539	2961	0.169
	R08X1-316BA	±0.08	1.0	6.0	368	297	1229	0.175
	R10X1-316BA	±0.08	1.0	8.0	294	242	953	0.225
	R10X1.5-316BA		1.5	7.0	441	349	1524	0.319
	R10X2-316BA		2.0	6.0	588	447	2182	0.401
	R12X1-316BA	±0.08	1.0	10.0	245	205	779	0.275
	R12X1.5-316BA		1.5	9.0	368	297	1229	0.394
	R12X2-316BA		2.0	8.0	490	383	1732	0.501
	R15X1.5-316BA	±0.08	1.5	12.0	294	242	953	0.507
R16X2-316		±0.08	2.0	12.0	368	297	1229	0.701
R16X2.5-316			2.5	11.0	459	362	1601	0.845
R18X1.5-316		±0.08	1.5	15.0	245	205	779	0.620
R18X2-316			2.0	14.0	327	267	1074	0.801
R20X2-316		±0.08	2.0	16.0	294	242	953	0.901
R20X2.5-316			2.5	15.0	368	297	1229	1.096
R22X2-316		±0.08	2.0	18.0	267	222	857	1.002
R25X2-316		±0.08	2.0	21.0	235	197	745	1.152
R25X2.5-316			2.5	20.0	294	242	953	1.409
R25X3-316			3.0	19.0	353	286	1172	1.653
R28X2-316		±0.08	2.0	24.0	210	177	659	1.302
R30X2.5-316		±0.08	2.5	25.0	245	205	779	1.722
R30X3-316			3.0	24.0	294	242	953	2.028
R35X3-316		±0.15	3.0	29.0	252	210	803	2.404
R38X3-316		±0.15	3.0	32.0	232	195	734	2.629
R38X4-316			4.0	30.0	309	254	1010	3.405
R38X5-316			5.0	28.0	387	311	1305	4.132
R38X6-316			6.0	26.0	464	365	1621	4.808
R42X3-316			±0.20	3.0	36.0	210	177	659

Other sizes on request!

EO-Tubes for fitting systems (Industrial- and Mobile-Applications)

Seamless EO stainless steel tubes | Material 316L (1.4404/1.4435)

Acc. to DIN EN 10216-5, DIN EN 10305-1

1. DIN 2413 I: Tubes with a diameter of OD/ID>2 are calculated for static stress in accordance with DIN 2413 III but with K=yield strength.
2. Burst pressure (B.P.) calculation acc. to Faupel-von-Mises

Material 316 L (1.4404)	d _a Outer-Ø (mm)		s Wallthickness		d Inner-Ø (mm)	Design pressure		2 Burst pressure bar	Weight kg/m
						1	DIN 2413 III		
	Surface bright annealed	Inch	mm	Inch		mm	DIN 2413 I static PN bar		
Order code									
R1/8X0.028TP316/L	1/8	3.18	0.028	0.71	1.76	659	492	2538	0.044
R3/16X0.035TP316/L	3/16	4.76	0.035	0.89	2.98	549	422	1996	0.086
R1/4X0.035TP316/L	1/4	6.35	0.035	0.89	4.57	412	328	1403	0.122
R1/4X0.049TP316/L			0.049	1.24	3.87	576	440	2126	0.159
R1/4X0.065TP316/L			0.065	1.65	3.05	619	556	3135	0.194
R3/8X0.035TP316/L	3/8	9.53	0.035	0.89	7.75	274	227	883	0.193
R3/8X0.049TP316/L			0.049	1.24	7.05	384	309	1294	0.257
R3/8X0.065TP316/L			0.065	1.65	6.23	510	396	1818	0.326
R1/2X0.035TP316/L	1/2	12.70	0.035	0.89	10.92	206	174	644	0.263
R1/2X0.049TP316/L			0.049	1.24	10.22	288	238	932	0.356
R1/2X0.065TP316/L			0.065	1.65	9.40	382	307	1286	0.457
R1/2X0.083TP316/L			0.083	2.11	8.48	488	381	1724	0.560
R5/8X0.049TP316/L	5/8	15.88	0.049	1.24	13.40	230	193	729	0.455
R5/8X0.065TP316/L			0.065	1.65	12.58	306	251	996	0.588
R3/4X0.049TP316/L	3/4	19.05	0.049	1.24	16.57	192	163	598	0.553
R3/4X0.065TP316/L			0.065	1.65	15.75	255	212	813	0.719
R3/4X0.083TP316/L			0.083	2.11	14.83	325	266	1069	0.895
R3/4X0.095TP316/L			0.095	2.41	14.23	372	300	1248	1.004
R3/4X0.109TP316/L			0.109	2.77	13.51	427	339	1467	1.129
R1X0.065TP316/L	1	25.40	0.065	1.65	22.10	191	162	595	0.981
R1X0.083TP316/L			0.083	2.11	21.18	244	204	775	1.231
R1X0.095TP316/L			0.095	2.41	20.58	279	231	900	1.387
R1X0.126TP316/L			0.126	3.20	19.00	370	299	1240	1.779

Other sizes on request!





E0-Tubes for flange systems

Marine- and Offshore-Applications

Industrial- and Mobile-Applications

Overview EO flange systems

The Parflange® F37 Programme consists of two flange connection technologies:
The 37° Flare Flange Connection and the Retaining Ring Connection.

F37 Flaring system



The advantages

- No welding
- No post-weld cleaning
- No welding stress corrosion possible
- No "hot work" permit required
- Workshop prefabrication
- Easy dismantling and reassembling

In this configuration, the deburred tube end is flared orbitally to 37° by Parflange® technology. An insert, soft sealed by an O-ring, is located into each pipe end. In between a F37 Seal (optionally Bonded Seal or O-ring) is placed. By tightening the flanges together, a soft sealed, high pressure tube connection is made. Available as tube-to-tube connection or tube-to-port connection. The Parflange® F37 flanged connector system is utilising this orbital tube forming technology for tubing assemblies from 16 to 168.3 mm (1/2" to 6" Flanges) outside diameter. It is intended for tube wall thickness up to 9 mm and pressure ratings up to 420 bar. It is available as a high pressure version from 1 1/2" to 10" and as a newly developed SAE 1000 (50-70 bar) version.

F37 Retaining ring system



The advantages

- No welding
- No post-weld cleaning
- No welding stress corrosion possible
- No "hot work" permit required
- Workshop prefabrication
- Easy dismantling and reassembling

The retaining ring used in this connection is a stainless steel segmented ring covered by a stainless steel spring. It is assembled in a machined groove on the tube end or adapter. When tightening this system, the flange is pushed against the retaining ring, thus giving a form tight connection. Retaining ring connections complete the Parflange® F37 range with bulkhead, male, female, weld and tube bend connections.

It is available as a high pressure version from 1 1/2" to 10" and as a newly developed SAE 1000 (50-70 bar) version.

HPF - High Performance flange system

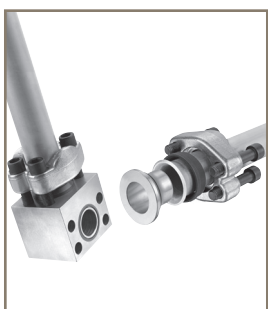

The advantages

- With HPF zinc-plated tubes can be used
- Welding seams must not be descaled and stained
- Tubes assembled with HPF do not require any cleaning
- The flanging process does not cause noxious gases, thus eliminating explosion and fire hazards

Parker's HPF system has been specially designed and developed to meet the requirements of mobile hydraulic and industrial equipment: high performance and high pressure. The HPF system is adjusted to standard tube dimensions used in these industries. Diameters from 25 to 150 mm and wall thicknesses up to 17.5 mm. The system is designed for flange patterns according to ISO 6162-1 (SAE J518, code 61), ISO 6162-2 (SAE J518, code 62) and ISO 6164.

The lockring constitutes the core of the HPF connector. It is specially hardened, phosphated and manufactured with a particular contour. This ring supporting the tube on the outside provides additional tear-off safety for the connection. Depending on the size of the tube the safety function of the lockring is substituted for a specially designed and hardened one-piece flange with an adapted internal contour. An insert is placed into the flared end of the tube. On the port side the sealing is guaranteed selectively by a special profile seal or an O-ring seal, on the tube side by an O-ring seal. The application of these soft-sealing elements both on the port side and the tube side guarantees the gas leak tightness of the HPF connector. As the insert does not have a toothed profile, it can be easily assembled repeatedly.

Overview E0 steel tubes for flange systems

Material E235+N / St.37.4 (1.0308)		Flange system		
Surface		F37 Flare	F37 Retaining ring	HPF
Phosphated and oiled	Cr(VI)-free			
Order code				
R12X1.5	R12X1.5CF	-	X*	-
R16X2	R16X2CF	X	X*	-
R18X2	R18X2CF	X	X*	-
R20X2	R20X2CF	X	-	-
R20X2.5	R20X2.5CF	X	X*	-
R25X2.5	R25X2.5CF	X	X*	-
R25X3	R25X3CF	X	X*	-
R30X3	R30X3CF	X	X*	-
R30X4	R30X4CF	X	X*	-
	R38X2.5CF	X	-	-
R38X3	R38X3CF	X	-	-
R38X4	R38X4CF	X	X*	-
R38X5	R38X5CF	X	X*	-
R38X7		-	X*	-
R42X2	R42X2CF	X	-	-
R42X3	R42X3CF	X	X*	-
R42X4	R42X4CF	X	X*	-
R50X3	R50X3CF	X	X*	-
R50X6		X	X*	-
R60X3	R60X3CF	X	X*	-
R65X8		-	X*	-
R75X3	R75X3CF	X	X*	-
R90X3.5	R90X3.5CF	X	X*	-
R100X4		X	X*	-
R115X4		X	-	-
R140X4.5		X	X*	-
R165X5		X	X*	-
R220X6		X	X*	-
R273X6		X	X*	-

Material E355+N / St.52.4 (1.0580)		Flange system		
Surface		F37 Flare	F37 Retaining ring	HPF
Phosphated and oiled	Cr(VI)-free			
Order code				
	R12X1.5ST52CF	-	X*	-
R16X2ST52	R16X2ST52CF	X	X*	-
	R18X2ST52CF	X	X*	-
	R20X2ST52CF	X	-	-
R20X2.5ST52	R20X2.5ST52CF	X	X*	-
	R25X2.5ST52CF	X	X*	-
R25X3ST52	R25X3ST52CF	X	X*	X
	R25X4ST52CF	-	-	X
R30X3ST52	R30X3ST52CF	X	X*	-
	R30X4ST52CF	X	X*	X
	R30X5ST52CF	-	-	X
	R38X3ST52CF	X	-	-
R38X4ST52	R38X4ST52CF	X	X*	X
	R38X5ST52CF	X	X*	X
	R38X6ST52CF	-	-	X
	R39X7.5ST52CF	-	X	-
	R42X3ST52CF	X	X*	-
	R42X4ST52CF	X	X*	X
	R42X5ST52CF	-	-	X
	R46X8ST52CF	-	X*	-
	R50X3ST52CF	X	X*	X
R50X5ST52	R50X5ST52CF	X	X*	X
	R50X6ST52CF	X	X*	X
	R50X8ST52CF	-	-	X
R56X8.5ST52	R56X8.5ST52CF	-	X	-
	R60X3ST52CF	X	X*	-
	R60X5ST52CF	X	X*	X
R60X6ST52	R60X6ST52CF	X	X*	X
	R60X8ST52CF	-	X*	X
R60X10ST52		-	X*	X
	R65X8ST52CF	-	X*	X
R66X8.5ST52	R66X8.5ST52CF	-	X	X
R73X7ST52	R73X7ST52CF	X	X*	X
R75X5ST52	R75X5ST52CF	X	X*	-
R75X12.5ST52		-	-	X
R80X3ST52		-	-	X
R80X8ST52		-	-	X
R80X10ST52		-	X	X
R88X14ST52		-	-	X
R90X3.5ST52		X	X*	-
R90X5ST52		X	X*	X
R90X9ST52		X	X*	X
R97X12ST52		-	X	X
R101.6X16ST52		-	-	X
R114.3X17.5ST52		-	X	X
R115X15ST52		-	X	X
R120X20ST52		-	-	X
R130X15ST52		-	X	X
R150X15ST52		-	X	X
R190X20ST52		-	X	-
R250X25ST52		-	X	-

X*= Retaining ring weld adapter

Other sizes on request!

Overview EO stainless steel tubes for flange systems

Material 316Ti (1.4571)	Flange system		
	F37 Flare	F37 Retaining ring	HPF
Order code			
R12X1.571	-	X*	-
R16X271	X	X*	-
R18X271	X	X*	-
R20X271	X	-	-
R20X2.571	X	X*	-
R25X2.571	X	X*	-
R25X371	X	X*	-
R30X371	X	X*	-
R30X471	X	X*	-
R38X2.571	X	-	-
R38X471	X	X*	-
R42X371	X	X*	-

Material 316L (1.4404)	Flange system		
	F37 Flare	F37 Retaining ring	HPF
Order code			
R21.34X2.11-316	on request	X*	-
R21.34X2.77-316	on request	X*	-
R21.34X3.73-316	on request	X*	-
R21.34X4.78-316	-	X*	-
R26.67X2.11-316	on request	X*	-
R26.67X2.87-316	on request	X*	-
R26.67X3.91-316	on request	X*	-
R26.67X5.56-316	-	X*	-
R33.40X2.77-316-A999	on request	X*	-
R33.40X3.38-316-A999	on request	X*	-
R33.40X4.55-316-A999	-	X*	-
R33.40X6.35-316-A999	-	X*	-
R42.16X2.77-316-A999	on request	X*	-
R42.16X3.56-316-A999	on request	X*	-
R42.16X4.85-316-A999	on request	X*	-
R42.16X6.35-316-A999	-	X*	-
R48.26X2.77-316-A999	on request	X*	-
R48.26X3.68-316-A999	on request	X*	-
R48.26X5.08-316-A999	on request	X*	-
R48.26X7.14-316-A999	-	X*	-
R60.33X2.77-316-A999	on request	X*	-
R60.33X3.92-316-A999	on request	X*	-
R60.33X5.54-316-A999	on request	X*	-
R60.33X8.74-316-A999	-	X*	-
R73.03X3.05-316-A999	on request	X*	-
R73.03X5.16-316-A999	on request	X*	-
R73.03X7.01-316-A999	on request	X*	-
R73.03X9.52-316-A999	-	X	-
R88.90X3.05-316	X	X*	-
R88.90X5.49-316-A999	on request	X*	-
R88.90X7.62-316-A999	on request	X*	-
R88.90X11.13-316-A999	-	X	-
R114.30X3.05-316-A999	on request	X*	-
R114.30X6.02-316-A999	on request	X*	-
R114.30X8.56-316-A999	-	X*	-
R114.30X13.49-316-A999	-	X	-
R141.30X6.55-316-A999	on request	X*	-
R141.30X9.53-316-A999	-	X*	-
R141.30X15.88-316-A999	-	X	-
R168.26X3.40-316	on request	X*	-
R168.28X7.11-316-A999	-	X*	-
R168.28X18.26-316-A999	-	X	-
R219.08X8.18-316	-	X*	-
R219.08X23.01-316-A999	-	X	-
R273.05X25.40-316-A999	-	X	-

Material 316L (1.4404)	Flange system				
	Surface pickled	Surface bright annealed	F37 Flare	F37 Retaining ring	HPF
		R12X1.5-316BA	-	X*	-
R16X2-316			X	X*	-
R18X2-316			X	X*	-
R20X2-316			X	-	-
R20X2.5-316			X	X*	-
R25X2.5-316			X	X*	-
R25X3-316			X	X*	-
R30X3-316			X	X*	-
R30X4-316			X	X*	-
R38X2.5-316			X	-	-
R38X3-316			X	-	-
R38X4-316			X	X*	-
R38X5-316			X	X*	-
R42X3-316			X	X*	-
R50X3-316			X	X*	-
R50X5-316			X	X*	-
R50X6-316			X	X*	-
R60X3-316			X	X*	-
R60X5-316			X	X*	-
R60X6-316			X	X*	-
R66X8.5-316			-	X	-
R73X7-316			-	X*	-
R75X3-316			X	X*	-
R75X5-316			X	X*	-
R80X10-316			-	X	-

X* = Retaining ring weld adapter

Other sizes on request!



Seamless EO steel tubes | Material E235+N / St.37.4 (1.0308)

Acc. to DIN EN 10305-1

1. DNV Bended pipe including manufacturing and corrosion tolerances.
2. DNV Straight pipe including manufacturing and corrosion tolerances.
3. Burst pressure (B.P.) calculation = Based on Tensile value, wall thickness tolerance not included.

Material E235+N / St.37.4 (1.0308)		d _a Outer-Ø (mm)	Outer-Ø Tolerance (mm)	s Wall- thickness (mm)	d _i Inner-Ø (mm)	Design pressure		3 Burst pressure bar	Weight kg/m
Surface						1 DNV PN bar	2 DNV PN bar		
Phosphated and oiled	Cr(VI)-free								
Order code									
R12X1.5	R12X1.5CF	12	±0.08	1.5	9.0	218	250	1114	0.388
R16X2	R16X2CF	16	±0.08	2.0	12.0	235	270	1114	0.691
R18X2	R18X2CF	18	±0.08	2.0	14.0	207	237	975	0.789
R20X2	R20X2CF	20	±0.08	2.0	16.0	185	212	867	0.888
R20X2.5	R20X2.5CF	20		2.5	15.0	246	282	1114	1.079
R25X2.5	R25X2.5CF	25	±0.08	2.5	20.0	193	221	867	1.387
R25X3	R25X3CF	25		3.0	19.0	242	277	1064	1.628
R30X3	R30X3CF	30	±0.08	3.0	24.0	198	227	867	1.998
R30X4	R30X4CF	30		4.0	22.0	281	323	1200	2.565
R38X3 R38X4 R38X5	R38X2.5CF	38	±0.15	2.5	33.0	124	141	549	2.189
	R38X3CF	38		3.0	32.0	154	176	669	2.589
	R38X4CF	38		4.0	30.0	217	248	918	3.354
	R38X5CF	38		5.0	28.0	282	324	1182	4.069
R42X2	R42X2CF	42	±0.20	2.0	38.0	85	97	390	1.973
R42X3	R42X3CF	42		3.0	36.0	139	158	600	2.885
R42X4	R42X4CF	42		4.0	34.0	194	223	821	3.748
R50X3	R50X3CF	50	±0.20	3.0	44.0	115	132	498	3.477
R50X6		50		6.0	38.0	258	296	1064	6.511
R60X3	R60X3CF	60	±0.25	3.0	54.0	95	109	411	4.217
R65X8		65	±0.30	8.0	49.0	270	310	1095	11.245
R75X3	R75X3CF	75	±0.35	3.0	69.0	76	86	325	5.327
R90X3.5	R90X3.5CF	90	±0.40	3.5	83.0	75	85	316	7.466
R100X4		100	±0.45	4.0	92.0	78	89	325	9.470
R115X4		115	±0.50	4.0	107.0	68	77	281	10.949
R140X4.5		140	±0.70	4.5	131.0	63	72	259	15.037
R165X5		165	±0.90	5.0	155.0	60	68	244	19.729
R220X6		220	±1.10	6.0	208.0	55	62	219	31.665
R273X6		273	±1.40	6.0	261.0	44	50	175	39.507

Surface finish:

- Tubes with I.D. 1.5-5 mm: outside and inside oiled.
- Tubes from 6 mm I.D.: outside and inside phosphated and oiled.

• Cr(VI)-free:

These dimensions are externally thick coat passivated (thickness of coat 8-12µm), inside oiled.

Other sizes on request!

Seamless EO steel tubes | Material E235+N / St.37.4 (1.0308)

Acc. to DIN EN 10305-1

1. DIN 2413 I static pressure (W.P.) capability for straight pipe including manufacturing tolerance.
2. DIN 2413 III dynamic pressure (W.P.) capability for straight pipe including manufacturing tolerance.
3. Burst pressure (B.P.) calculation acc. to Faupel-von-Mises

Material E235+N / St.37.4 (1.0308)		d _a Outer-Ø (mm)	Outer-Ø Tolerance (mm)	s Wall- thickness (mm)	d _i Inner-Ø (mm)	Design pressure		3 Burst pressure bar	Weight kg/m
Surface Phosphated and oiled	Cr(VI)-free					1 DIN 2413 I static PN bar	2 DIN 2413 III dynamic PN bar		
Order code									
R12X1.5	R12X1.5CF	12	±0.08	1.5	9.0	353	303	1022	0.388
R16X2	R16X2CF	16	±0.08	2.0	12.0	353	303	1022	0.691
R18X2	R18X2CF	18	±0.08	2.0	14.0	313	273	893	0.789
R20X2	R20X2CF	20	±0.08	2.0	16.0	282	248	793	0.888
R20X2.5	R20X2.5CF	20	±0.08	2.5	15.0	353	303	1022	1.079
R25X2.5	R25X2.5CF	25	±0.08	2.5	20.0	282	248	793	1.387
R25X3	R25X3CF	25	±0.08	3.0	19.0	338	292	975	1.628
R30X3	R30X3CF	30	±0.08	3.0	24.0	282	248	793	1.998
R30X4	R30X4CF	30	±0.08	4.0	22.0	376	321	1102	2.565
R38X3	R38X2.5CF	38	±0.15	2.5	33.0	186	168	501	2.189
R38X3	R38X3CF	38	±0.15	3.0	32.0	223	199	610	2.589
R38X4	R38X4CF	38	±0.15	4.0	30.0	297	260	840	3.354
R38X5	R38X5CF	38	±0.15	5.0	28.0	371	318	1085	4.069
R42X2	R42X2CF	42	±0.20	2.0	38.0	134	123	355	1.973
R42X3	R42X3CF	42	±0.20	3.0	36.0	201	181	547	2.885
R42X4	R42X4CF	42	±0.20	4.0	34.0	269	237	750	3.748
R50X3	R50X3CF	50	±0.20	3.0	44.0	169	154	454	3.477
R50X6	R50X6CF	50	±0.20	6.0	38.0	338	292	975	6.511
R60X3	R60X3CF	60	±0.25	3.0	54.0	141	129	374	4.217
R65X8	R65X8CF	65	±0.30	8.0	49.0	347	299	1004	11.245
R75X3	R75X3CF	75	±0.35	3.0	69.0	113	104	296	5.327
R90X3.5	R90X3.5CF	90	±0.40	3.5	83.0	110	101	288	7.466
R100X4	R100X4CF	100	±0.45	4.0	92.0	113	104	296	9.470
R115X4	R115X4CF	115	±0.50	4.0	107.0	98	91	256	10.949
R140X4.5	R140X4.5CF	140	±0.70	4.5	131.0	91	84	236	15.037
R165X5	R165X5CF	165	±0.90	5.0	155.0	85	80	222	19.729
R220X6	R220X6CF	220	±1.10	6.0	208.0	77	72	199	31.665
R273X6	R273X6CF	273	±1.40	6.0	261.0	62	58	160	39.507

Surface finish:

- Tubes with I.D. 1.5-5 mm: outside and inside oiled.
- Tubes from 6 mm I.D.: outside and inside phosphated and oiled.

• Cr(VI)-free:

These dimensions are externally thick coat passivated (thickness of coat 8-12µm), inside oiled.

Other sizes on request!



Seamless E0 steel tubes | Material E355+N / St.52.4 (1.0580)

Acc. to DIN EN 10305-1

1. DNV Bended pipe including manufacturing and corrosion tolerances.
2. DNV Straight pipe including manufacturing and corrosion tolerances.
3. Burst pressure (B.P.) calculation = Based on Tensile value, wall thickness tolerance not included.

Material E355+N / St. 52.4 (1.0580)		d _a Outer-Ø (mm)	Outer-Ø Tolerance (mm)	s Wall- thickness (mm)	d _i Inner-Ø (mm)	Design pressure		3 Burst pressure bar	Weight kg/m
Surface Phosphated and oiled	Cr(VI)-free					1 DNV PN bar	2 DNV PN bar		
Order code									
	R12X1.5ST52CF	12	±0.08	1.5	9.0	330	378	1523	0.388
R16X2ST52	R16X2ST52CF	16	±0.08	2.0	12.0	355	408	1523	0.691
	R18X2ST52CF	18	±0.08	2.0	14.0	313	358	1333	0.789
R20X2ST52	R20X2ST52CF	20	±0.08	2.0	16.0	279	319	1184	0.888
R20X2.5ST52	R20X2.5ST52CF	20		2.5	15.0	371	426	1523	1.079
R25X3ST52	R25X2.5ST52CF	25	±0.08	2.5	20.0	291	333	1184	1.387
	R25X3ST52CF	25		3.0	19.0	365	418	1454	1.628
	R25X4ST52CF	25		4.0	17.0	519	599	2030	2.072
R30X3ST52	R30X3ST52CF	30	±0.08	3.0	24.0	299	343	1184	1.998
	R30X4ST52CF	30		4.0	22.0	424	487	1640	2.565
	R30X5ST52CF	30		5.0	20.0	555	641	2132	3.083
R38X4ST52	R38X3ST52CF	38	±0.15	3.0	32.0	233	266	914	2,589
	R38X4ST52CF	38		4.0	30.0	327	375	1254	3.354
	R38X5ST52CF	38		5.0	28.0	426	490	1615	4.069
	R38X6ST52CF	38		6.0	26.0	529	611	1999	4.735
	R39X7.5ST52CF	39	±0.15	7.5	24.0	673	781	2538	5.826
	R42X3ST52CF	42	±0.20	3.0	36.0	209	239	820	2.885
	R42X4ST52CF	42		4.0	34.0	294	336	1122	3.748
	R42X5ST52CF	42		5.0	32.0	381	438	1441	4.562
	R46X8ST52CF	46		±0.20	8.0	30.0	601	695	2244
R50X5ST52	R50X3ST52CF	50	±0.20	3.0	44.0	174	199	680	3.477
	R50X5ST52CF	50		5.0	40.0	315	361	1184	5.549
	R50X6ST52CF	50		6.0	38.0	390	448	1454	6.511
	R50X8ST52CF	50		8.0	34.0	546	631	2030	8.286
R56X8.5ST52	R56X8.5ST52CF	56	±0.25	8.5	39.0	516	595	1908	9.957
R60X6ST52	R60X3ST52CF	60	±0.25	3.0	54.0	144	164	561	4.217
	R60X5ST52CF	60		5.0	50.0	259	297	969	6.782
	R60X6ST52CF	60		6.0	48.0	319	366	1184	7.990
	R60X8ST52CF	60		8.0	44.0	445	512	1640	10.259
R60X10ST52		60		10.0	40.0	578	668	2132	12.331
	R65X8ST52CF	65	±0.30	8.0	49.0	407	468	1496	11.245
R66X8.5ST52	R66X8.5ST52CF	66	±0.30	8.5	49.0	429	494	1576	12.053
R73X7ST52	R73X7ST52CF	73	±0.35	7.0	59.0	308	353	1131	11.393
R75X5ST52	R75X5ST52CF	75	±0.35	5.0	65.0	205	234	761	8.631
R75X12.5ST52		75		12.5	50.0	583	674	2132	19.266
R80X3ST52		80	±0.35	3.0	74.0	107	122	415	5.697
R80X8ST52		80		8.0	64.0	325	372	1184	14.205
R80X10ST52		80		10.0	60.0	418	481	1523	17.263
R88X14ST52		88	±0.40	14.0	60.0	554	640	2017	25.549
R90X3.5ST52		90	±0.40	3.5	83.0	113	129	431	7.466
R90X5ST52		90		5.0	80.0	169	193	627	10.481
R90X9ST52		90		9.0	72.0	326	374	1184	17.978
R97X12ST52		97	±0.45	12.0	73.0	416	478	1505	25.154
R115X15ST52		115	±0.50	15.0	85.0	444	511	1599	36.992
R120X20ST52		120	±0.50	20.0	80.0	590	682	2132	49.322
R130X15ST52		130	±0.70	15.0	100.0	388	445	1390	42.540
R150X15ST52		150	±0.80	15.0	120.0	332	380	1184	49.939
R190X20ST52		190	±1.00	20.0	150.0	353	405	1254	83.847
R250X25ST52		250	±1.30	25.0	200.0	335	384	1184	138.718

Other sizes on request!

Seamless EO steel tubes | Material E355+N / St.52.4 (1.0580)

Acc. to DIN EN 10305-1

1. DIN 2413 I static pressure (W.P.) capability for straight pipe including manufacturing tolerance.
2. DIN 2413 III dynamic pressure (W.P.) capability for straight pipe including manufacturing tolerance.
3. Burst pressure (B.P.) calculation acc. to Faupel-von-Mises

Material E355+N / St. 52.4 (1.0580)		d _a Outer-Ø (mm)	OuterØ Tolerance (mm)	s Wal- thickness (mm)	d _i Inner-Ø (mm)	Design pressure		3 Burst pressure bar	Weight kg/m
Surface						1 DIN 2413 I static PN bar	2 DIN 2413 III dynamic PN bar		
Phosphated and oiled	Cr(VI)-free								
Order code									
	R12X1.5ST52CF	12	±0.08	1,5	9.0	533	357	1504	0.388
R16X2ST52	R16X2ST52CF	16	±0.08	2.0	12.0	533	357	1504	0.691
	R18X2ST52CF	18	±0.08	2.0	14.0	473	321	1314	0.789
R20X2ST52	R20X2ST52CF	20	±0.08	2.0	16.0	426	292	1167	0.888
R20X2.5ST52	R20X2.5ST52CF	20		2.5	15.0	533	357	1504	1.079
	R25X2.5ST52CF	25	±0.08	2.5	20.0	426	292	1167	1.387
R25X3ST52	R25X3ST52CF	25		3.0	19.0	511	344	1435	1.628
	R25X4ST52CF	25		4.0	17.0	682	445	2016	2.072
R30X3ST52	R30X3ST52CF	30	±0.08	3.0	24.0	426	292	1167	1.998
	R30X4ST52CF	30		4.0	22.0	568	379	1622	2.565
	R30X5ST52CF	30		5.0	20.0	710	461	2120	3.083
	R38X3ST52CF	38	±0.15	3.0	32.0	336	234	899	2.589
R38X4ST52	R38X4ST52CF	38		4.0	30.0	448	306	1236	3.354
	R38X5ST52CF	38		5.0	28.0	561	374	1597	4.069
	R38X6ST52CF	38		6.0	26.0	673	440	1984	4.735
	R39X7.5ST52CF	39		±0.15	7.5	24.0	819	521	2539
	R42X3ST52CF	42	±0.20	3.0	36.0	304	213	806	2.885
	R42X4ST52CF	42		4.0	34.0	406	279	1105	3.748
	R42X5ST52CF	42		5.0	32.0	507	342	1422	4.562
	R46X8ST52CF	46	±0.20	8.0	30.0	741	478	2235	7.497
R50X5ST52	R50X3ST52CF	50	±0.20	3.0	44.0	256	181	668	3.477
	R50X5ST52CF	50		5.0	40.0	426	292	1167	5.549
	R50X6ST52CF	50		6.0	38.0	511	344	1435	6.511
	R50X8ST52CF	50		8.0	34.0	682	445	2016	8.286
R56X8.5ST52	R56X8.5ST52CF	56	±0.25	8.5	39.0	647	425	1892	9.957
	R60X3ST52CF	60	±0.25	3.0	54.0	213	152	551	4.217
R60X6ST52	R60X5ST52CF	60		5.0	50.0	355	247	953	6.782
	R60X6ST52CF	60		6.0	48.0	426	292	1167	7.990
	R60X8ST52CF	60		8.0	44.0	568	379	1622	10.259
R60X10ST52		60		10.0	40.0	710	461	2120	12.331
	R65X8ST52CF	65	±0.30	8.0	49.0	524	352	1477	11.245
R66X8.5ST52	R66X8.5ST52CF	66	±0.30	8.5	49.0	549	367	1557	12.053
R73X7ST52	R73X7ST52CF	73	±0.35	7.0	59.0	408	281	1113	11.393
R75X5ST52	R75X5ST52CF	75	±0.35	5.0	65.0	284	200	748	8.631
R75X12.5ST52		75		12.5	50.0	710	461	2120	19.266
R80X3ST52		80	±0.35	3.0	74.0	160	115	408	5.697
R80X8ST52		80		8.0	64.0	426	292	1167	14.205
R80X10ST52		80		10.0	60.0	533	357	1504	17.263
R88X14ST52		88	±0.40	14.0	60.0	678	443	2002	25.549
R90X3.5ST52		90	±0.40	3.5	83.0	166	119	423	7.466
R90X5ST52		90		5.0	80.0	237	168	616	10.481
R90X9ST52		90		9.0	72.0	426	292	1167	17.978
R97X12ST52		97	±0.45	12.0	73.0	527	354	1486	25.154
R115X15ST52		115	±0.50	15.0	85.0	556	371	1580	36.992
R120X20ST52		120	±0.50	20.0	80.0	710	461	2120	49.322
R130X15ST52		130	±0.70	15.0	100.0	492	332	1372	42.540
R150X15ST52		150	±0.80	15.0	120.0	426	292	1167	49.939
R190X20ST52		190	±1.00	20.0	150.0	448	306	1236	83.847
R250X25ST52		250	±1.30	25.0	200.0	426	292	1167	138.718

Other sizes on request!



Seamless cold drawn EO stainless steel tube | Material 316Ti (1.4571)

Acc. to DIN 10216-5, DIN EN 10305-1

1. DNV Bended pipe including manufacturing and corrosion tolerances.
2. DNV Straight pipe including manufacturing and corrosion resistance.
3. Burst pressure (B.P.) calculation = Based on Tensile value, wall thickness tolerance not included.

Material 316Ti (1.4571) Surface bright annealed Order code	d _a Outer-Ø (mm)	OuterAußen-Ø Tolerance (mm)	s Wall- thickness (mm)	d _i Inner-Ø (mm)	Design pressure		3 Burst pressure bar	Weight kg/m
					1 DNV PN bar	2 DNV PN bar		
					R12X1.571	12		
R16X271	16	±0.08	2.0	12.0	380	437	1514	0.701
R18X271	18	±0.08	2.0	14.0	334	383	1325	0.801
R20X271	20	±0.08	2.0	16.0	298	341	1178	0.901
R20X2.571	20		2.5	15.0	380	437	1514	1.096
R25X2.571	25	±0.08	2.5	20.0	298	341	1178	1.409
R25X371	25		3.0	19.0	363	418	1445	1.653
R30X371	30	±0.08	3.0	24.0	298	341	1178	2.028
R30X471	30		4.0	22.0	409	470	1631	2.604
R38X2.571	38	±0.15	2.5	33.0	190	217	746	2.222
R38X471	38		4.0	30.0	315	361	1247	3.405
R42X371	42		±0.20	3.0	36.0	207	237	815

Other sizes on request!

Seamless cold drawn EO stainless steel tube | Material 316Ti (1.4571)

Acc. to DIN 10216-5, DIN EN 10305-1

1. DIN 2413 I static pressure (W.P.) capability for straight pipe including manufacturing tolerance.
2. DIN 2413 III dynamic pressure (W.P.) capability for straight pipe including manufacturing tolerance.
3. Burst pressure (B.P.) calculation acc. to Faupel-von-Mises.

Material 316Ti (1.4571) Surface bright annealed Order code	d _a Outer-Ø (mm)	Outer-Ø Tolerance (mm)	s Wall- thickness (mm)	d _i Inner-Ø (mm)	Design pressure		3 Burst pressure bar	Weight kg/m
					1 DIN 2413 I static PN bar	2 DIN 2413 III dynamic PN bar		
					R12X1.571	12		
R16X271	16	±0.08	2.0	12.0	368	297	1229	0.701
R18X271	18	±0.08	2.0	14.0	327	267	1074	0.801
R20X271	20	±0.08	2.0	16.0	294	242	953	0.901
R20X2.571	20	±0.08	2.5	15.0	368	297	1229	1.096
R25X2.571	25	±0.08	2.5	20.0	294	242	953	1.409
R25X371	25	±0.08	3.0	19.0	353	286	1172	1.653
R30X371	30	±0.08	3.0	24.0	294	242	958	2.028
R30X471	30	±0.08	4.0	22.0	392	314	1325	2.604
R38X2.571	38	±0.15	2.5	33.0	193	164	603	2.222
R38X471	38	±0.15	4.0	30.0	309	254	1010	3.405
R42X371	42	±0.20	3.0	36.0	210	177	659	2.930

Other sizes on request!



Seamless cold drawn E0 stainless steel tube | Material 316L (1.4404)

Acc. to DIN 10216-5, DIN 10305-1 (-316BA); ASTM A269/A213 (-316)

1. DNV Bended pipe including manufacturing and corrosion tolerances.
2. DNV Straight pipe including manufacturing and corrosion tolerances.
3. Burst pressure (B.P.) calculation = Based on Tensile value, wall thickness tolerance not included.

Material 316L (1.4404)		d _a Outer-Ø (mm)	Outer-Ø Tolerance (mm)	s Wall- thickness (mm)	d _i Inner-Ø (mm)	Design pressure		3 Burst pressure bar	Weight kg/m
Surface pickled	bright annealed					1 DNV PN bar	2 DNV PN bar		
Order code									
	R12X1.5-316BA	12	±0.08	1.5	9.0	380	437	1514	0.394
R16X2-316		16	±0.08	2.0	12.0	380	437	1514	0.701
R18X2-316		18	±0.08	2.0	14.0	334	383	1325	0.801
R20X2-316		20	±0.08	2.0	16.0	298	341	1178	0.901
R20X2.5-316		20	±0.08	2.5	15.0	380	437	1514	1.096
R25X2.5-316		25	±0.08	2.5	20.0	298	341	1178	1.409
R25X3-316		25	±0.08	3.0	19.0	363	418	1445	1.653
R30X3-316		30	±0.08	3.0	24.0	298	341	1178	2.028
R30X4-316		30	±0.08	4.0	22.0	409	470	1631	2.604
R38X2.5-316		38	±0.15	2.5	33.0	190	217	746	2.222
R38X3-316		38	±0.15	3.0	32.0	231	264	909	2.629
R38X4-316		38	±0.15	4.0	30.0	315	361	1247	3.405
R38X5-316		38	±0.15	5.0	28.0	403	463	1606	4.132
R42X3-316		42	±0.20	3.0	36.0	207	237	815	2.930
R50X3-316		50	±0.20	3.0	44.0	173	197	677	3.531
R50X5-316		50	±0.20	5.0	40.0	298	341	1178	5.634
R50X6-316		50	±0.20	6.0	38.0	363	418	1445	6.611
R60X3-316		60	±0.25	3.0	54.0	143	163	558	4.282
R60X5-316		60	±0.25	5.0	50.0	244	280	964	6.886
R60X6-316		60	±0.25	6.0	48.0	298	341	1178	8.113
R66X8.5-316		66	±0.30	8.5	49.0	393	452	1567	12.238
R73X7-316		73	±0.35	7.0	59.0	284	326	1124	11.568
R75X3-316		75	±0.35	3.0	69.0	113	129	442	5.409
R75X5-316		75	±0.35	5.0	65.0	193	220	757	8.764
R80X10-316		80	±0.35	10.0	60.0	380	437	1514	17.528

Other sizes on request!

Seamless cold drawn EO stainless steel tube | Material 316L (1.4404)

Acc. to DIN 10216-5, DIN 10305-1 (-316BA); ASTM A269/A213 (-316)

1. Due to Parker's high quality standards, the pickled tubes (-316) are calculated according to the values of bright annealed tubes (-316BA). Nominal pressure calculation based on these mechanical properties requires certification in accordance with 3.1 - EN 10204, which confirms the mechanical properties
2. DIN 2413 I static pressure (W.P.) capability for straight pipe including manufacturing tolerance.
3. DIN 2413 III dynamic pressure (W.P.) capability for straight pipe including manufacturing tolerance.
4. Burst pressure (B.P.) calculation acc. to Faupel-von-Mises

Material 316L (1.4404)		d _a Outer-Ø (mm)	Outer-Ø Tolerance (mm)	s Wall- thickness (mm)	d _i Inner-Ø (mm)	Design pressure		4 Burst pressure bar	Weight kg/m
Surface						2 DIN 2413 I static PN bar	3 DIN 2413 III dynamic PN bar		
1 pickled	bright annealed								
Order code									
	R12X1.5-316BA	12	±0.08	1.5	9.0	368	297	1229	0.394
R16X2-316		16	±0.08	2.0	12.0	368	297	1229	0.701
R18X2-316		18	±0.08	2.0	14.0	327	267	1074	0.801
R20X2-316		20		2.0	16.0	294	242	953	0.901
R20X2.5-316		20	±0.08	2.5	15.0	368	297	1229	1.096
R25X2.5-316		25		2.5	20.0	294	242	953	1.409
R25X3-316		25	±0.08	3.0	19.0	353	286	1172	1.653
R30X3-316		30		3.0	24.0	294	242	953	2.028
R30X4-316		30	±0.08	4.0	22.0	392	314	1325	2.604
R38X2.5-316		38		2.5	33.0	193	164	603	2.222
R38X3-316		38		3.0	32.0	232	195	734	2.629
R38X4-316		38	±0.15	4.0	30.0	309	254	1010	3.405
R38X5-316		38		5.0	28.0	387	311	1305	4.132
R42X3-316		42	±0.20	3.0	36.0	210	177	659	2.930
R50X3-316		50		3.0	44.0	176	150	546	3.531
R50X5-316		50	±0.20	5.0	40.0	294	242	953	5.634
R50X6-316		50		6.0	38.0	353	286	1172	6.611
R60X3-316		60		3.0	54.0	147	126	450	4.282
R60X5-316		60	±0.25	5.0	50.0	245	205	779	6.886
R60X6-316		60		6.0	48.0	294	242	953	8.113
R66X8.5-316		66	±0.30	8.5	49.0	379	305	1272	12.238
R73X7-316		73	±0.35	7.0	59.0	282	233	910	11.568
R75X3-316		75		3.0	69.0	118	102	356	5.409
R75X5-316		75	±0.35	5.0	65.0	196	166	611	8.764
R80X10-316		80	±0.35	10.0	60.0	368	297	1229	17.528

Other sizes on request!



Seamless stainless steel tubes | Material 316L (1.4404)

Acc. to ASTM A312/A999

1. DNV Bended pipe including manufacturing and corrosion tolerances.
2. DNV Straight pipe including manufacturing and corrosion tolerances.
3. Burst pressure (B.P.) calculation = Based on Tensile value, wall thickness tolerance not included.

Material 316L (1.4404)	da Outer-Ø		s Wallthickness		di Inner-Ø (mm)	Design pressure		3 Burst pressure bar	Weight kg/m	
	SCH	mm	SCH	mm		1	2			
						DNV PN bar	DNV PN bar			
Surface pickled										
Order code										
R21.34X2.11-316	1/2"	21.34	SCH 10	2.11	17.12	241	277	1130	1.014	
R21.34X2.77-316			SCH 40	2.77	15.80	325	374	1536	1.285	
R21.34X3.73-316			SCH 80	3.73	13.88	456	527	2182	1.641	
R21.34X4.78-316			SCH 160	4.78	11.78	611	712	2973	1.977	
R26.67X2.11-316	3/4"	26.67	SCH 10	2.11	24.56	190	217	885	1.299	
R26.67X2.81-316			SCH 40	2.81	21.05	259	297	1213	1.713	
R26.67X3.91-316			SCH 80	3.91	18.85	373	430	1769	2.231	
R26.67X5.56-316			SCH 160	5.56	15.55	560	651	2713	2.943	
R33.40X2.77-316-A999	1"	33.40	SCH 10	2.77	27.86	200	228	931	2.125	
R33.40X3.38-316-A999			SCH 40	3.38	30.02	247	284	1160	2.541	
R33.40X4.55-316-A999			SCH 80	4.55	24.30	343	395	1624	3.287	
R33.40X6.35-316-A999			SCH 160	6.35	20.70	502	583	2418	4.301	
R42.16X2.77-316-A999	1 1/4"	42.16	SCH 10	2.77	36.62	156	178	724	2.735	
R42.16X3.56-316-A999			SCH 40	3.56	35.04	204	233	950	3.444	
R42.16X4.85-316-A999			SCH 80	4.85	32.46	285	327	1339	4.536	
R42.16X6.35-316-A999			SCH 160	6.35	29.46	384	443	1826	5.700	
R48.26X2.77-316-A999	1 1/2"	48.26	SCH 10	2.77	42.72	135	154	627	3.158	
R48.26X3.68-316-A999			SCH 40	3.68	40.90	183	209	850	4.112	
R48.26X5.08-316-A999			SCH 80	5.08	38.10	258	296	1212	5.498	
R48.26X7.14-316-A999			SCH 160	7.14	33.98	377	434	1788	7.359	
R60.33X2.77-316-A999	2"	60.33	SCH 10	2.77	54.76	107	122	496	3.990	
R60.33X3.91-316-A999			SCH 40	3.91	52.48	154	176	714	5.521	
R60.33X5.54-316-A999			SCH 80	5.54	49.22	223	255	1041	7.596	
R60.33X8.74-316-A999			SCH 160	8.74	42.82	368	424	1745	11.284	
R73.03X3.05-316-A999	2 1/2"	73.03	SCH 10	3.05	66.90	97	111	449	5.342	
R73.03X5.16-316-A999			SCH 40	5.16	62.68	168	192	783	8.765	
R73.03X7.01-316-A999			SCH 80	7.01	58.98	234	268	1094	11.583	
R73.03X9.53-316-A999			SCH 160	9.53	53.94	327	376	1546	15.146	
R88.90X3.05-316	3"	88.90	SCH 10	3.05	82.80	79	90	366	6.557	
R88.90X5.49-316-A999			SCH 40	5.49	77.92	146	167	678	11.466	
R88.90X7.62-316-A999			SCH 80	7.62	73.56	207	237	966	15.509	
R88.90X11.13-316-A999			SCH 160	11.13	66.64	312	359	1474	21.674	
R114.30X3.05-316	4"	114.30	SCH 10	3.05	108.20	61	70	282	8.496	
R114.30X6.02-316-A999			SCH 40	6.02	102.16	124	141	573	16.322	
R114.30X8.56-316-A999			SCH 80	8.56	97.18	179	205	834	22.665	
R114.30X13.49-316-A999			SCH 160	13.49	87.32	293	336	1378	34.053	
R141.30X6.55-316-A999	5"	141.30	SCH 40	6.55	128.20	108	123	501	22.101	
R141.30X9.53-316-A999			SCH 80	9.53	122.24	160	183	745	31.444	
R141.30X15.88-316-A999			SCH 160	15.88	109.54	277	318	1304	49.871	
R168.28X3.40-316	6"	168.28	SCH 10	3.40	161.48	46	53	212	14.039	
R168.28X7.11-316-A999			SCH 40	7.11	154.08	98	112	454	28.697	
R168.28X18.26-316-A999			SCH 160	18.26	131.78	267	306	1254	68.603	
R219.08X8.18-316	8"	219.08	SCH 40	8.18	202.72	87	99	399	43.202	
R219.08X23.01-316-A999			SCH 160	23.01	173.06	258	296	1209	112.981	
R273.05X25.40-316-A999	10"	273.05	XXS	25.40	222.25	226	259	1057	157.509	

Other sizes on request!

Conversion tables

Temperature conversion table

Celsius to Fahrenheit

°C	°F
150	302
145	293
140	284
135	275
130	266
125	257
120	248
115	239
110	230
105	221
100	212
95	203
90	194
85	185
80	176
75	167
70	158
65	149
60	140
55	131
50	122
45	113
40	104
35	95
30	86
25	77
20	68
15	59
10	50
5	41
0	32
-5	23
-10	14
-15	5
-20	-4
-25	-13
-30	-22
-35	-31
-40	-40
-45	-49
-50	-58

Fahrenheit to Celsius

°F	°C
340	171
330	166
320	160
310	154
300	149
290	143
280	138
270	132
260	127
250	121
240	116
230	110
220	104
210	99
200	93
190	88
180	82
170	77
160	71
150	66
140	60
130	54
120	49
110	43
100	38
90	32
80	27
70	21
60	16
50	10
40	4
30	-1
20	-7
10	-12
0	-18
-10	-23
-20	-29
-30	-34
-40	-40
-50	-46
-60	-51

Pressure conversion table

bar to psi

bar	psi
1000	14505
800	11604
600	8703
500	7253
400	5802
250	3626
160	2321
100	1451
60	870
40	580
35	508
25	363
16	232
10	145
6	87
4	58
2.5	36
1.6	23
1	15

psi to bar

psi	bar
10000	689
9000	620
7000	483
6000	414
4000	276
3000	207
2500	172
1000	69
900	62
600	41
500	34
400	28
250	17
150	10.3
100	6.9
90	6.2
60	4.1
40	2.8
25	1.7
10	0.7

Examples

Temperature conversion

Initial value: 100
 °C to °F: 212 °F
 °F to °C: 37,78 °C

Pressure conversion

Initial value: 35
 bar to psi: 507.675 psi
 psi to bar: 2.41296 bar

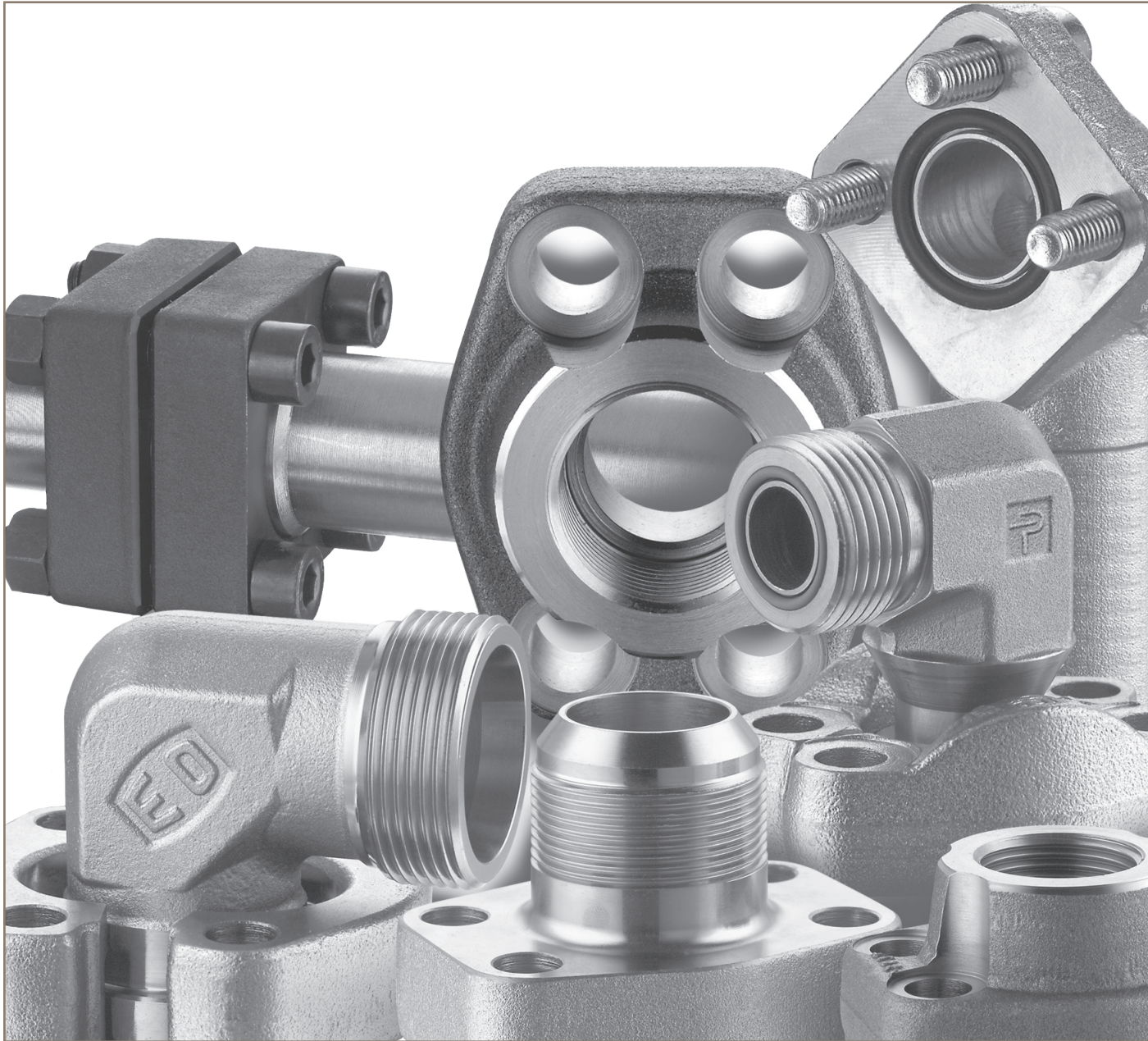

SAE Flange adapters

For a full range of SAE and ISO Flange Connectors, Pump Flanges and Flange Accessories please see Catalogue 4100 Chapter M.

www.parker.com/hpce

Resources

General Documentation

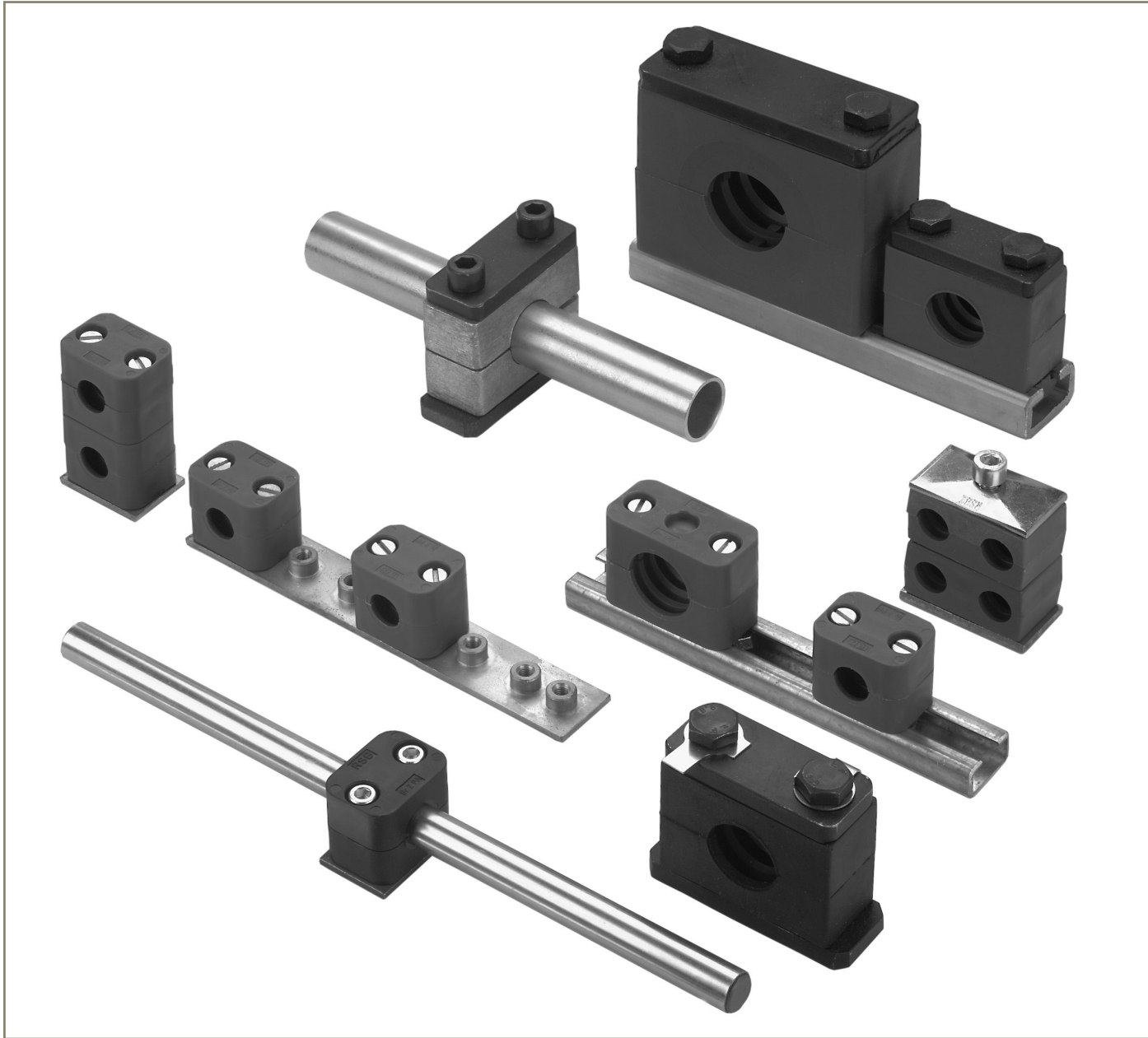

Tube clamps

For a full range of Tube Clamps according to DIN3015 and other clamp solutions please see Catalogue 4100 Chapter S.

www.parker.com/hpce 
Resources 
General Documentation