



aerospace  
climate control  
electromechanical  
filtration  
**fluid & gas handling**  
hydraulics  
pneumatics  
process control  
sealing & shielding



# Solenoid valves and pressure regulators for the railway industry



ENGINEERING YOUR SUCCESS.

# Parker Fluid Control Division Europe - FCDE

## About Us

*The Fluid Control Division Europe (FCDE) is a division of Parker Hannifin, a leader in the movement and control technologies sector.*

*The basic skills in the FCDE division are the development and manufacture of a range of products for controlling fluids, comprising solenoid valves and pressure regulators.*

## Where To Find Us

*Our head office is in Geneva along with R&D, marketing, application support, and product management.*

*FCDE products are mainly manufactured in Carouge (Geneva, Switzerland) and Gessate (Milan, Italy).*

*Parker Sales Companies and their extensive sales and service network provide support throughout Europe.*

## History

For more than 60 years, Parker FCDE has been a leader in the manufacture and development of solenoid valve technologies. Through its continuous research and development, the company has been able to offer innovative solutions to the market and introduce, for example, the use of synthetic ruby for critical applications with water or the reliability and unequalled accuracy of our pressure regulators. The know-how acquired and developed over the years has resulted in FCDE's solutions being of the highest quality.

## Markets served

Our products and solutions are typically designed for the following business sectors: industrial equipment, industrial automation, mobile systems, transportation, life sciences, beverage dispensers, and the control of fluids and processes.

## Benefits

The modular design of our products integrating solenoid valves and separate electrical parts provides customers with greater flexibility by allowing them to use a variety of combinations. This increased flexibility allows distributors to reduce their stock of valves to a greater extent while continuing to offer the widest range. Parker also benefits from unrivalled experience in the development of custom products to the strictest technical, environmental, energy, and endurance requirements.



PARKER FCDE - GENEVA - SWITZERLAND



PARKER FCDE - MILAN - ITALY

# Contents

Solenoid valves and pressure regulators for controlling fluids in the railway industry.....	04
A range of solenoid valves for fluid control applications in the railway industry .....	05
Solenoid Valves: Applications .....	06
Solenoid Valves: General specifications table.....	10
Solenoid Valves: Technical characteristics table.....	11
Coils for solenoid valves.....	12
Solenoid Valves: Dimensional drawings.....	14
Pressure Regulators: Applications .....	16
EPP3 pressure regulators: Technical characteristics table.....	17
EPP3 pressure regulators: Dimensional drawings.....	18



## WARNING - USER'S RESPONSIBILITIES

**FAILURE TO FOLLOW THE INSTRUCTIONS OR THE IMPROPER SELECTION OR INAPPROPRIATE USE OF THE PRODUCTS OR RELATED ITEMS DESCRIBED IN THIS DOCUMENT COULD RESULT IN DEATH, PERSONAL INJURY, OR DAMAGE TO PROPERTY.**

- This document and any other information originating from Parker-Hannifin Corporation, its subsidiaries, or approved distributors refer to products and systems that should be tested and checked by competent users with technical expertise.
- On completion of his/her own analyses and tests, the user alone is responsible for the final choice of system and components and for ensuring that all conditions with regard to performance, durability, maintenance, safety, and caution for the application have been met. It is his/her responsibility to analyze all aspects of the application, to apply current industrial standards and to take on board information about the product appearing in the latest edition of the catalogue, plus any other documents supplied by Parker, its subsidiaries, or approved distributors.
- To the extent that Parker, its subsidiaries, or approved distributors supply component or system options based on data or specifications supplied by the user, it is the user's responsibility to establish that these data and specifications are appropriate and adequate for all reasonably foreseeable applications and uses of the components or systems.

# Solenoid valves and pressure regulators for controlling fluids in the railway industry

Parker is the world leader in fluid movement and control technology. We provide solutions designed for the rail transport industry with products which are extremely reliable, even under the most demanding environmental conditions. In spite of extreme weather phenomena, high levels of vibration, the presence of dust and aggressive contamination, the railway industry seeks to become ever more competitive, so our technical knowledge and customer service skills will always be a guarantee of results.

Our solenoid valves and pressure regulators used for controlling fluids in the railway industry are fully suited to handling these difficult conditions, maximizing reliability for the customer by reducing rolling stock operating costs.

So, by working with a recognized world leader in fluids control and technology, you will be assured of the best service with a technology that meets all your requirements.

## Collaboration... Creating solutions

Our world is much more than manufacturing standard components adapted for unique needs. Working together with you, we will produce solutions that not only meet your requirements but which also offer commercial and environmental advantages.

Our team of Parker engineers and technical support personnel aim to meet specifications and rigorous functional requirements to ensure the development of components and systems solutions that meet railway standards and meet application needs.

At Parker, we are committed to excellence, by encouraging transparency, creative interaction between professionals, and discussions on best practice.

We believe that the sharing of knowledge, skills, and experience provides the key to obtaining the most technically efficient and commercially viable results. Thus, from design to production, an open dialogue is always ensured.



# A range of solenoid valves for fluid control applications in the railway industry

The Parker FCDE range for the railway industry includes normally closed, normally open, or bi-stable 2/2 direct control solenoid valves; normally closed, normally open, or universal 3/2 direct control solenoid valves, and also pressure regulators for all fluids present in on-board equipment: air, oil, water, etc.

Here are some standard application examples for using solenoid valves and pressure regulators.

- **Driving cab**
  - ▶ Windscreen wiper control
  - ▶ Audible warning control
  - ▶ Cab heating control
- **Air production**
  - ▶ Condensate drain
- **Diesel engines**
  - ▶ Solenoid valve for oil, air, water
- **Bogies and brakes**
  - ▶ Sanding control
  - ▶ Lateral suspension control
  - ▶ Braking / Anti-jamming control
- **Toilets**
  - ▶ Drinking water supply
  - ▶ Toilet water supply
- **Doors and steps**
  - ▶ Outer door control
  - ▶ Step control
- **Electrical circuit**
  - ▶ Circuit breaker

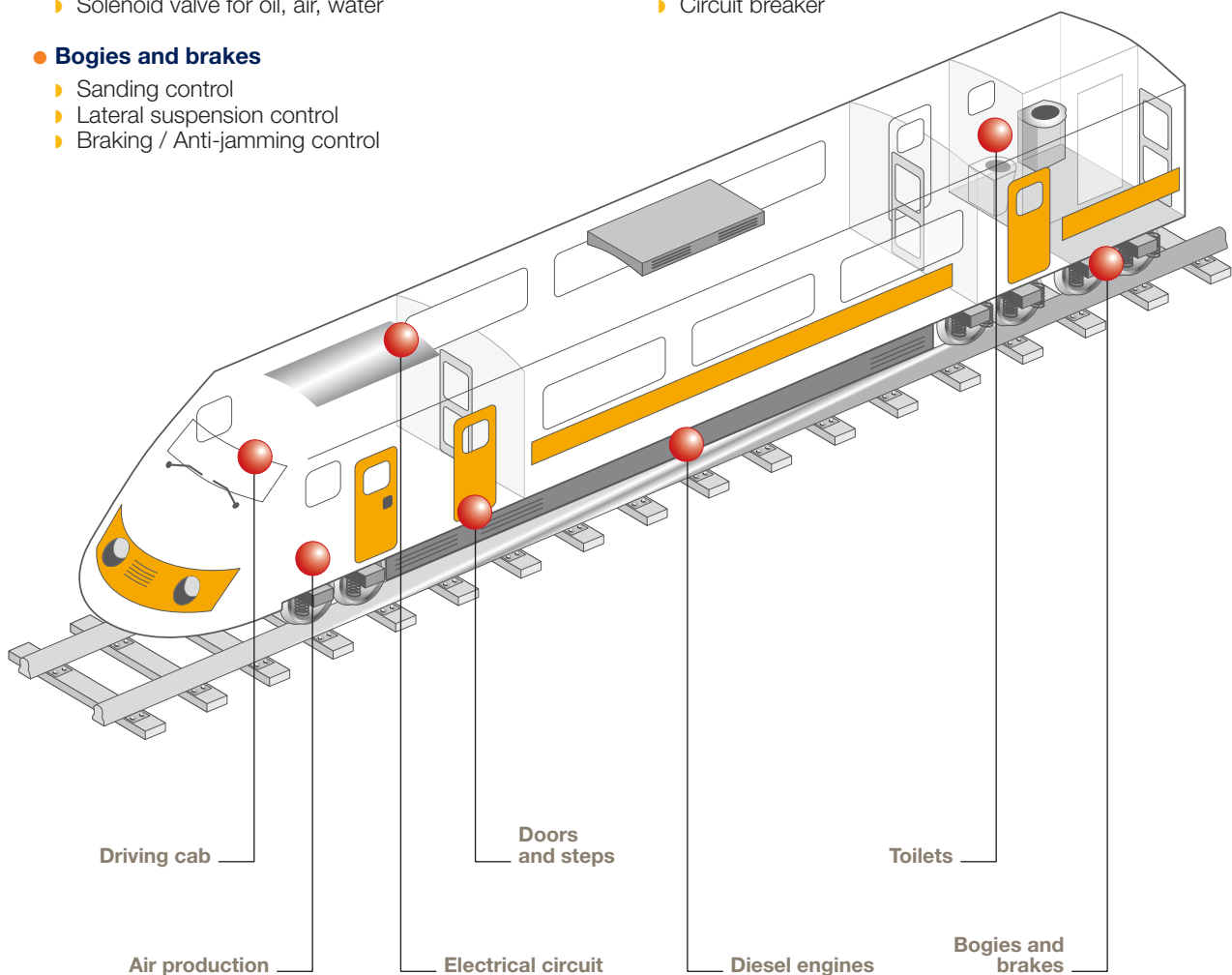

# Solenoid Valves

## Applications

### Driving cab



#### > Windscreen wiper control

**Fluid:** Air

**Valve reference:** E131K04

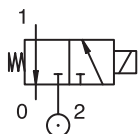

**Benefits:** Reduced dimensions, easy installation, good internal sealing.



#### > Warning horn

**Fluid:** Air

**Valve reference:** E121K07

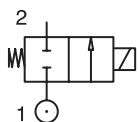

**Benefits:** Reduced dimensions, easy installation, long-life check valve.

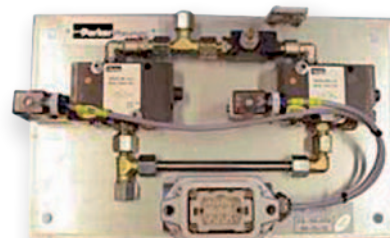

#### > Cabin heating

**Fluid:** Hot water

**Valve reference:** Normally open 122KS4074A

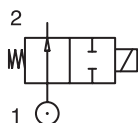

**Benefits:** High flow rate, zero pressure difference.



# Solenoid Valves

## Applications

### Air production



#### > Purge solenoid valve

**Fluid:** Air

**Valve references:** Normally closed E121K63-E121K0402-E121K04  
Normally open 122K8406-122K8306-122K8311

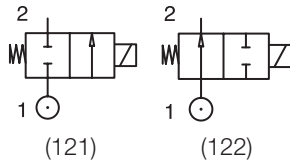

**Benefits:** Compact valves, limited power (9 W when hot), any orientation, great reliability, pilot can be delivered on its own (valve without body).

#### > Compressor vent solenoid valve

**Fluid:** Air

**Valve references:** Normally open 122K8408 -122K8406 - 122K8306 - 122K8311

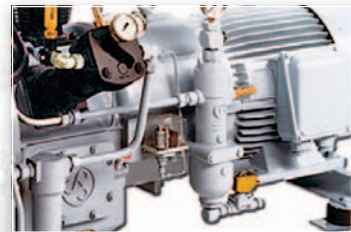
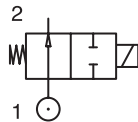

**Benefits:** Compact valves, limited power (9 W when hot), any orientation, great reliability, pilot can be delivered on its own (valve without body).

## Diesel engine

#### > Water, air, or oil solenoid supply valve (lubrication system)

**Fluid:** Water, air, oil

**Valve reference:** E121K45

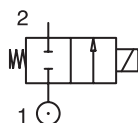

**Benefits:** Compact high flow rate valve (air 2,500 l/min, oil 20 l/min), limited power (9 W when hot).

# Solenoid Valves

## Applications

### Bogies and brakes



#### > Sanding control

Fluid: Air

Valve references: 131M74 - 131M75

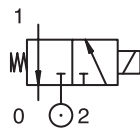

**Benefits:** Low power (2.5 W), simplified fitting plan, reduced dimensions.



## Electrical circuit

#### > Circuit breaker

Fluid: Air

Solenoid control valve  
with pneumatic actuator: 131FS9366

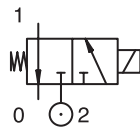

**Benefits:** Usable at low temperature (-40°C), manual control, easy installation.



# Solenoid Valves

## Applications

### Doors and steps



#### > Door control

**Fluid:** Air

**Valve references:**  
Normally open  
122K8306 - 122K8406

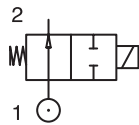

**Benefits:** Safety valves (open circuit in the event of a supply fault).

#### > Step control

**Fluid:** Air

**Valve references:**  
E131F4350 - 131F4650

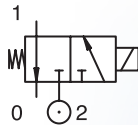

**Benefits:** Compact valves, easy installation, manual control.



## Toilets



#### > Drinking water supply

**Fluid:** Water

**Valve ref.:** 121V5163

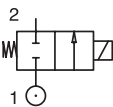

**Benefits:** Stainless steel 303, ruby check valve, compatible with drinking water, direct control, high flow rate valve.

#### > Toilet water supply

**Fluid:** Air

**Valve ref.:** 131T21

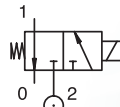

**Benefits:** Compact valve (3 connections integrated into the valve body).



# Solenoid Valves

## General specifications table

<b>Function</b>	2/2 NF & NO 3/2 NF & NO & Universal
<b>Technology</b>	Direct control
<b>Fluid</b>	All fluids (air, water, oils, etc.)
<b>Max. pressure differential</b>	Between 0 and 40 bar (depending on orifice)
<b>Connection</b>	¼"G - ½"G - Flanged and specials
<b>Manual control</b>	"Quarter turn" type - Available according to reference
<b>Seat seal</b>	FKM, EPDM, Ruby, PCTFE, PUR
<b>Material - Body</b>	Brass or stainless steel 303
<b>Material - Control</b>	Stainless Steel
<b>Material - Electrical part</b>	PBT (polybutylene terephthalate) Class F or PPS (phenylene polysulfide) Class H
<b>Protection</b>	IP65 with DIN 43650A connector
<b>Power Supply</b>	12, 24, 48, 72, 90, 96, 110 VDC & 220-230/50 VAC
<b>Electrical voltage range *</b>	-25% to +30%
<b>Electrical power</b>	9 W under 100% ED (12.5 W under 0% ED) 2.5 W under 100% ED (3 W under 0% ED) 5 W under 100% ED (6.5 W under 0% ED)
<b>Ambient temperature*</b>	-40°C to +50°C with 100% ED permanent engagement with Class F coil -40°C to +70°C with 100% ED permanent engagement with Class H coil
<b>Fluid temperature*</b>	-40°C to +100°C
<b>Storage temperature</b>	-40°C to +80°C
<b>Service life</b>	> 1 million operations
<b>Vibration resistance</b>	Test conducted on request
<b>Impact resistance</b>	Test conducted on request
<b>Internal leakage rate*</b>	≤2 Ncm <sup>3</sup> /min for elastomer check valve down to -15°C
<b>Electromagnetic compatibility</b>	DIN EN 61000-6-3 compatibility and DIN EN 61000-6-2 immunity
<b>RoHS</b>	In accordance with current standard
<b>Fire/smoke standard</b>	Product not submitted due to the bulk of the materials concerned in accordance with NF F16-101 / 102 / 103

\* For extreme combined conditions, please contact the factory.

# Solenoid Valves

## Technical characteristics table

### 2-way valves

Reference	Function	Connection	Body material	Orifice (mm)	Qn (l/min)	Pressure range (bar)	Seat seal	Weight of solenoid valve (g)	Drawing
121F67	2/2 NF	Flanged	Brass	1.5	80	0-25	Ruby	280	A
121F4606	2/2 NF	Flanged	Brass	2	140	0-10	FKM	280	A
121F63	2/2 NF	Flanged	Brass	2.5	220	0-10	Ruby	280	A
121F64	2/2 NF	Flanged	Brass	3	320	0-7	Ruby	280	A
E121K0402	2/2 NF	¼"G	Brass	1.5	80	0-20	FKM	320	B
E121K04	2/2 NF	¼"G	Brass	1.5	80	0-25	PCTFE	320	B
121K0605	2/2 NF	¼"G	Brass	2	140	0-10	FKM	320	B
E121K07	2/2 NF	¼"G	Brass	2.5	220	1-10	PCTFE	320	B
E121K63	2/2 NF	¼"G	Brass	2.5	220	0-10	Ruby	280	B
121K0302	2/2 NF	¼"G	Brass	3	320	0-7	FKM	280	B
E121K45	2/2 NF	½"G	Brass	11	2,500	0-0.3	FKM	430	C
121V5163	2/2 NF	¼"G	Stainless steel	5	(kV 10)	0-2	Ruby	410	D
122K8406	2/2 NO	¼"G	Brass	1.5	80	0-20	FKM	320	B
122K8408	2/2 NO	¼"G	Brass	1.5	80	0-40	Ruby	320	B
122K8306	2/2 NO	¼"G	Brass	2.5	200	0-12	FKM	320	B
122K8311	2/2 NO	Pilot	-	2.5	200	0-12	FKM	320	B
122KS4074A	2/2 NO	20 mm dia.	Brass	18	(kV 50)	0-2	FKM	930	-

### 3-way valves

Reference	Function	Connection	Body material	Orifice (mm) (1) (2)	Qn (l/min)	Pressure range (bar)	Seat seal	Weight of solenoid valve (g)	Drawing
131FS9366*	3/2 NF	Flanged	Brass	1.5 / 1.5	80 / 80	2-10	PUR	280	E
E131F44	3/2 NF	Flanged	Brass	1.5 / 1.5	80 / 80	0-15	FKM	280	E
131F46	3/2 NF	Flanged	Brass	2 / 2.5	140 / 220	0-10	FKM	280	E
131F4650*	3/2 NF	Flanged	Brass	2 / 2.5	140 / 220	0-10	FKM	280	E
E131F43	3/2 NF	Flanged	Brass	2.5 / 2.5	220 / 220	0-7	FKM	280	E
E131F4350*	3/2 NF	Flanged	Brass	2.5 / 2.5	220 / 220	0-7	FKM	280	E
E131K04	3/2 NF	¼"G	Brass	1.5 / 1.5	80 / 80	0-16	FKM	320	F
E131K06	3/2 NF	¼"G	Brass	2 / 2.5	140 / 220	0-10	FKM	320	F
E131K03	3/2 NF	¼"G	Brass	2.5 / 2.5	220 / 220	0-7	FKM	320	F
131M74	3/2 NF	Flanged	Brass	1.5 / 1.5	70 / 70	0-7	FKM	120	G
131M75	3/2 NF	Flanged	Brass	1.2 / 1.5	50 / 70	0-10	FKM	120	G
131T21	3/2 NF	¼"G	Brass	4.5 / 6	500 / 750	0-2	FKM	400	H
132F44	3/2 NO	Flanged	Brass	1.5 / 1.5	80 / 80	0-16	FKM	280	E
132F46	3/2 NO	Flanged	Brass	2 / 2	125 / 125	0-10	FKM	280	E
132F4301	3/2 NO	Flanged	Brass	2.5 / 2.5	160 / 160	0-9	PUR	280	E
132K04	3/2 NO	¼"G	Brass	1.5 / 1.5	80 / 80	0-16	FKM	320	F
133F46	3/2 Universal	Flanged	Brass	2 / 2	140 / 140	0-7	FKM	280	E

\* With manual control.

# Coils for solenoid valves

## Coils for connecting to DIN plugs



### > 32 mm coils

These coils may be fitted on all Parker solenoid valves from this catalogue (Except for 131M74 and 131M75 use coil on page 13).

Encapsulated assembly comprising a coil, a magnetic circuit, and a plug-in connector.

The synthetic casing material (PBT or PPS) protects the compact assembly against the penetration of foreign bodies e.g. : dust, oil, water, etc.).

Easy to fit in confined spaces.

Protection against impacts and corrosion.

Coils comply with the European "low voltage" directive.



Features		Standard			High temperature				
References (without DIN plug)		481865			492453				
References (with DIN plug)		482725			492726				
Protection index		IP65 as per IEC/EN 60529 standards							
Insulation class		F 155°C			H 180°C				
Electrical connection		The coil is connected using a 2P+E plug as per EN 175301-803, type A.							
Ambient temperature		between -40°C and +50°C The application is also limited by the valve temperature range.							
Power Supply	DC	Pn (hot)	9 W			9 W			
		P (cold) 20°C	12 W			12 W			
	AC	Pn (holding)	8 W			8 W			
		Attraction (cold)	26VA (9 W)			26VA (9 W)			
Weight		130 g (without plug)							
"Un" voltages		VAC/Hz	Code	VDC	Code	VAC/Hz	Code	VDC	Code
between -10% and +10% of Un		220-230/50	3D	12	C1	220-230/50	3D	12	C1
				24	C2			24	C2
				48	C4			48	C4
				72	ON			110	C5
				90	M8				
				96	1T				
110	C5								

To order a coil, choose ref. coil + the voltage code, for example: 481865 for 24VDC = 481865C2

These coils must be used with suitable housings.

See examples below:

The coil assembly kit with reference 2995 corresponds to the numbering system for housing (valve - housing - coil - voltage).

It comprises a name plate with information on the type of valve with its main specifications, a washer, and a nut for fixing the 32 mm coil on the valve.

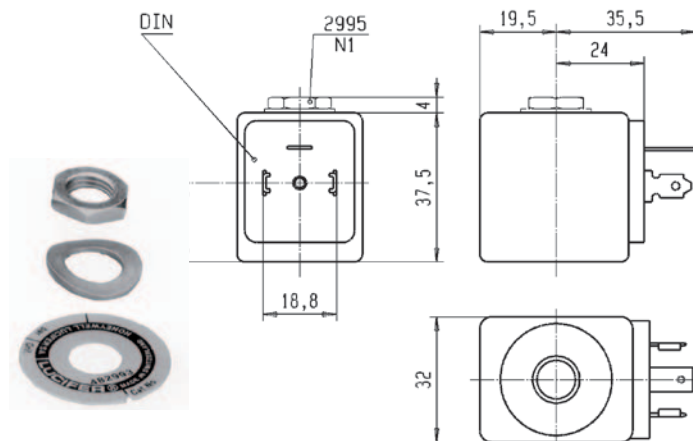

# Coils for solenoid valves

## Coils for connecting to DIN plugs



### > 22 mm coils

These coils may be fitted on Parker solenoid valves models 131M74, 131M75.

This coil was designed for valves fitted with a set of miniature tubes (series 2000 valves).

Encapsulated assembly comprising a coil, a magnetic circuit and a plug-in connector.

The synthetic casing material protects the compact assembly against the penetration of foreign bodies e.g. : dust, oil, water, etc.). Easy to fit in confined spaces - Protection against impacts and corrosion. This coil meets IEC/CENELEC safety standards and also the European "low voltage" directive.



Features		Low power			High power				
References (without DIN plug)		488980			481180				
References (with DIN plug)		481045			481530				
Protection index		IP65 as per IEC/EN 60529 standards (with DIN plug).							
Insulation class		F 155 C							
Electrical connection		The coil is connected using a 2P+E plug as per EN 175301-803, type B.							
Ambient temperature		between -40°C and +50°C The application is also limited by the valve temperature range.							
Power Supply	DC	Pn (hot)	2.5 W			5 W			
		P (cold) 20°C	3 W			6.5 W			
	AC	Pn (holding)	2 W			4 W			
		Attraction (cold)	5.7 VA (2.5 W)			8.9 VA (5 W)			
Weight		100 g with DIN plug							
"Un" voltages		VAC/Hz	Code	VDC	Code	VAC/Hz	Code	VDC	Code
between -10% and +10% of Un		220-230/50	3D	12 24 48 110	C1 C2 C4 C5	220-230/50	3D	12 24 110	C1 C2 C5

To order a coil, choose ref. coil + the voltage code, for example: 488980 for 24V dc = 488980C2  
Other possible voltages can be found in the voltage codes table at the end of the coils section.

These coils must be used with suitable housings.

See examples below:

The coil assembly kit with reference **8993** corresponds to the numbering system for housing (valve - housing - coil - voltage).

It comprises a name plate with information on the type of valve with its main specifications, a washer and a nut for fixing the 22 mm coil on the valve.

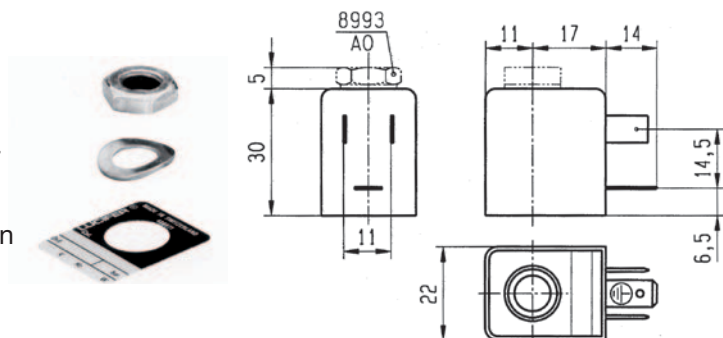

# 2-way solenoid valves

## Dimensional drawings

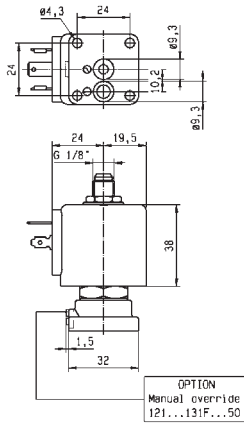

Drawing A

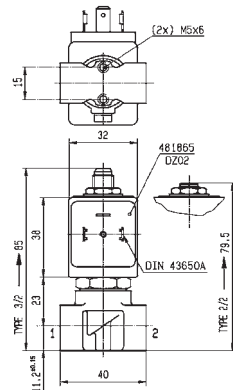
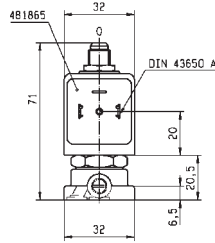

Drawing B

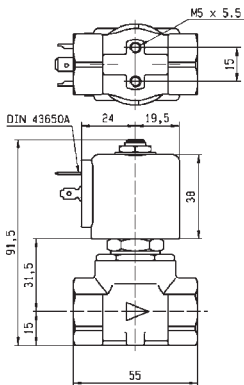
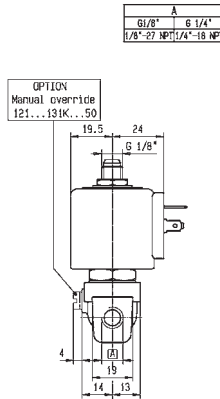

Drawing C

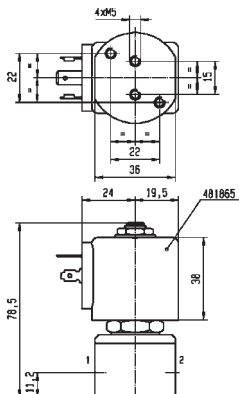
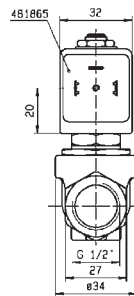

Drawing D

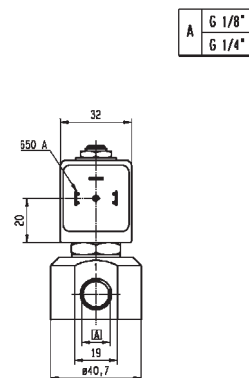



# Pressure regulators

## Applications

### Bogies and brakes



#### > Lateral suspension control

Pressure regulator mounted on a "Pendolino" type train. The pressure regulator ensures that the train is re-centered in relation to the track, counter-balancing the centrifugal force created when negotiating bends.

**Pressure regulator references:** EPP3BC41I10410  
EPP3BC41I12810A - EPP3BC41I17510 EPP3BC41I17610

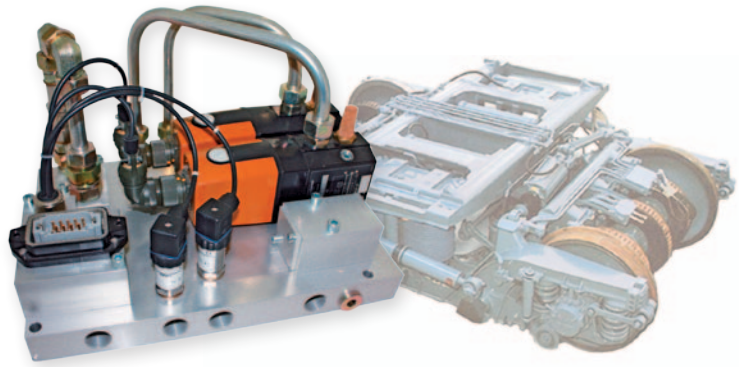

#### > Braking / Anti-skidding control

**Pressure regulator references:** EPP3BF41I10410 / EPP3BF41U10410



#### > Benefits

- Low consumption (3.5 W)
- Long service life (more than 300 million cycles)
- Integrated discharge valve
- Low temperature operation (down to -40°C)
- Product flanged as per ISO 3 (for EPP3 BF, etc.)
- Easy to install
- Meets EN50121.3.2, EN50155, EN61373
- Service kit and maintenance kit available

# EPP3 pressure regulators

## Technical characteristics table

### Pressure regulators

Regulator reference	Connection	Pressure range (bar)	Control signal	Operating range	Connector type	Electrical output	Weight (kg)
EPP3BC41I10410	½"G	0.2-10 bar	4-20 ma	-40°C +70°C	VEAM	Upper	2.1
EPP3BC41I12810A	½"G	0.2-10 bar	4-20 ma	-30°C +70°C	VEAM	Upper	2.1
EPP3BC41I17510	½"G	0.2-10 bar	4-20 ma	-30°C +70°C	VEAM	Lateral	2.1
EPP3BC41I17610	½"G	0.2-10 bar	4-20 ma	-40°C +70°C	VEAM	Lateral	2.1
EPP3BF41I10410	Flanged ISO 3	0.2-10 bar	4-20 ma	-40°C +70°C	VEAM	Upper	2.1
EPP3BF41U10410	Flanged ISO 3	0.2-10 bar	0-10 V	-40°C +70°C	VEAM	Upper	2.1







# Parker's Motion & Control Technologies

At Parker, we're guided by a relentless drive to help our customers become more productive and achieve higher levels of profitability by engineering the best systems for their requirements. It means looking at customer applications from many angles to find new ways to create value. Whatever the motion and control technology need, Parker has the experience, breadth of product and global reach to consistently deliver. No company knows more about motion and control technology than Parker. For further info call 00800 27 27 5374



## Aerospace Key Markets

Aftermarket services  
Commercial transports  
Engines  
General & business aviation  
Helicopters  
Launch vehicles  
Military aircraft  
Missiles  
Power generation  
Regional transports  
Unmanned aerial vehicles

## Key Products

Control systems & actuation products  
Engine systems & components  
Fluid conveyance systems & components  
Fluid metering, delivery & atomization devices  
Fuel systems & components  
Fuel tank inerting systems  
Hydraulic systems & components  
Thermal management  
Wheels & brakes



## Climate Control Key Markets

Agriculture  
Air conditioning  
Construction Machinery  
Food & beverage  
Industrial machinery  
Life sciences  
Oil & gas  
Precision cooling  
Process  
Refrigeration  
Transportation

## Key Products

Accumulators  
Advanced actuators  
CO<sub>2</sub> controls  
Electronic controllers  
Filter driers  
Hand shut-off valves  
Heat exchangers  
Hose & fittings  
Pressure regulating valves  
Refrigerant distributors  
Safety relief valves  
Smart pumps  
Solenoid valves  
Thermostatic expansion valves



## Electromechanical Key Markets

Aerospace  
Factory automation  
Life science & medical  
Machine tools  
Packaging machinery  
Paper machinery  
Plastics machinery & converting  
Primary metals  
Semiconductor & electronics  
Textile  
Wire & cable

## Key Products

AC/DC drives & systems  
Electric actuators, gantry robots & slides  
Electrohydraulic actuation systems  
Electromechanical actuation systems  
Human machine interface  
Linear motors  
Stepper motors, servo motors, drives & controls  
Structural extrusions



## Filtration Key Markets

Aerospace  
Food & beverage  
Industrial plant & equipment  
Life sciences  
Marine  
Mobile equipment  
Oil & gas  
Power generation & renewable energy  
Process  
Transportation  
Water Purification

## Key Products

Analytical gas generators  
Compressed air filters & dryers  
Engine air, coolant, fuel & oil filtration systems  
Fluid condition monitoring systems  
Hydraulic & lubrication filters  
Hydrogen, nitrogen & zero air generators  
Instrumentation filters  
Membrane & fiber filters  
Microfiltration  
Sterile air filtration  
Water desalination & purification filters & system



## Fluid & Gas Handling Key Markets

Aerial lift  
Agriculture  
Bulk chemical handling  
Construction machinery  
Food & beverage  
Fuel & gas delivery  
Industrial machinery  
Life sciences  
Marine  
Mining  
Mobile  
Oil & gas  
Renewable energy  
Transportation

## Key Products

Check valves  
Connectors for low pressure fluid conveyance  
Deep sea umbilicals  
Diagnostic equipment  
Hose couplings  
Industrial hose  
Mooring systems & power cables  
PTFE hose & tubing  
Quick couplings  
Rubber & thermoplastic hose  
Tube fittings & adapters  
Tubing & plastic fittings

## Hydraulics Key Markets

Aerial lift  
Agriculture  
Alternative energy  
Construction machinery  
Forestry  
Industrial machinery  
Machine tools  
Marine  
Material handling  
Mining  
Oil & gas  
Power generation  
Refuse vehicles  
Renewable energy  
Truck hydraulics  
Turf equipment

## Key Products

Accumulators  
Cartridge valves  
Electrohydraulic actuators  
Human machine interfaces  
Hybrid drives  
Hydraulic cylinders  
Hydraulic motors & pumps  
Hydraulic systems  
Hydraulic valves & controls  
Hydrostatic steering  
Integrated hydraulic circuits  
Power take-offs  
Power units  
Rotary actuators  
Sensors

## Pneumatics Key Markets

Aerospace  
Conveyor & material handling  
Factory automation  
Life science & medical  
Machine tools  
Packaging machinery  
Transportation & automotive

## Key Products

Air preparation  
Brass fittings & valves  
Manifolds  
Pneumatic accessories  
Pneumatic actuators & grippers  
Pneumatic valves & controls  
Quick disconnects  
Rotary actuators  
Rubber & thermoplastic hose & couplings  
Structural extrusions  
Thermoplastic tubing & fittings  
Vacuum generators, cups & sensors

## Process Control Key Markets

Alternative fuels  
Biopharmaceuticals  
Chemical & refining  
Food & beverage  
Marine & shipbuilding  
Medical & dental  
Microelectronics  
Nuclear Power  
Offshore oil exploration  
Oil & gas  
Pharmaceuticals  
Power generation  
Pulp & paper  
Steel  
Water/wastewater

## Key Products

Analytical Instruments  
Analytical sample conditioning products & systems  
Chemical injection fittings & valves  
Fluoropolymer chemical delivery fittings, valves & pumps  
High purity gas delivery fittings, valves, regulators & digital flow controllers  
Industrial mass flow meters/ controllers  
Permanent no-weld tube fittings  
Precision industrial regulators & flow controllers  
Process control double block & bleeds  
Process control fittings, valves, regulators & manifold valves

## Sealing & Shielding Key Markets

Aerospace  
Chemical processing  
Consumer  
Fluid power  
General industrial  
Information technology  
Life sciences  
Microelectronics  
Military  
Oil & gas  
Power generation  
Renewable energy  
Telecommunications  
Transportation

## Key Products

Dynamic seals  
Elastomeric o-rings  
Electro-medical instrument design & assembly  
EMI shielding  
Extruded & precision-cut, fabricated elastomeric seals  
High temperature metal seals  
Homogeneous & inserted elastomeric shapes  
Medical device fabrication & assembly  
Metal & plastic retained composite seals  
Shielded optical windows  
Silicone tubing & extrusions  
Thermal management  
Vibration dampening

ENGINEERING YOUR SUCCESS.

# Parker Worldwide

## Europe, Middle East, Africa

**AE – United Arab Emirates, Dubai**  
Tel: +971 4 8127100  
parker.me@parker.com

**AT – Austria, Wiener Neustadt**  
Tel: +43 (0)2622 23501-0  
parker.austria@parker.com

**AT – Eastern Europe, Wiener Neustadt**  
Tel: +43 (0)2622 23501 900  
parker.easteurope@parker.com

**AZ – Azerbaijan, Baku**  
Tel: +994 50 2233 458  
parker.azerbaijan@parker.com

**BE/LU – Belgium, Nivelles**  
Tel: +32 (0)67 280 900  
parker.belgium@parker.com

**BG – Bulgaria, Sofia**  
Tel: +359 2 980 1344  
parker.bulgaria@parker.com

**BY – Belarus, Minsk**  
Tel: +375 17 209 9399  
parker.belarus@parker.com

**CH – Switzerland, Etoy**  
Tel: +41 (0)21 821 87 00  
parker.switzerland@parker.com

**CZ – Czech Republic, Klecany**  
Tel: +420 284 083 111  
parker.czechrepublic@parker.com

**DE – Germany, Kaarst**  
Tel: +49 (0)2131 4016 0  
parker.germany@parker.com

**DK – Denmark, Ballerup**  
Tel: +45 43 56 04 00  
parker.denmark@parker.com

**ES – Spain, Madrid**  
Tel: +34 902 330 001  
parker.spain@parker.com

**FI – Finland, Vantaa**  
Tel: +358 (0)20 753 2500  
parker.finland@parker.com

**FR – France, Contamine s/Arve**  
Tel: +33 (0)4 50 25 80 25  
parker.france@parker.com

**GR – Greece, Athens**  
Tel: +30 210 933 6450  
parker.greece@parker.com

**HU – Hungary, Budaörs**  
Tel: +36 23 885 470  
parker.hungary@parker.com

**IE – Ireland, Dublin**  
Tel: +353 (0)1 466 6370  
parker.ireland@parker.com

**IT – Italy, Corsico (MI)**  
Tel: +39 02 45 19 21  
parker.italy@parker.com

**KZ – Kazakhstan, Almaty**  
Tel: +7 7273 561 000  
parker.easteurope@parker.com

**NL – The Netherlands, Oldenzaal**  
Tel: +31 (0)541 585 000  
parker.nl@parker.com

**NO – Norway, Asker**  
Tel: +47 66 75 34 00  
parker.norway@parker.com

**PL – Poland, Warsaw**  
Tel: +48 (0)22 573 24 00  
parker.poland@parker.com

**PT – Portugal, Leca da Palmeira**  
Tel: +351 22 999 7360  
parker.portugal@parker.com

**RO – Romania, Bucharest**  
Tel: +40 21 252 1382  
parker.romania@parker.com

**RU – Russia, Moscow**  
Tel: +7 495 645-2156  
parker.russia@parker.com

**SE – Sweden, Spånga**  
Tel: +46 (0)8 59 79 50 00  
parker.sweden@parker.com

**SK – Slovakia, Banská Bystrica**  
Tel: +421 484 162 252  
parker.slovakia@parker.com

**SL – Slovenia, Novo Mesto**  
Tel: +386 7 337 6650  
parker.slovenia@parker.com

**TR – Turkey, Istanbul**  
Tel: +90 216 4997081  
parker.turkey@parker.com

**UA – Ukraine, Kiev**  
Tel: +380 44 494 2731  
parker.ukraine@parker.com

**UK – United Kingdom, Warwick**  
Tel: +44 (0)1926 317 878  
parker.uk@parker.com

**ZA – South Africa, Kempton Park**  
Tel: +27 (0)11 961 0700  
parker.southafrica@parker.com

## North America

**CA – Canada, Milton, Ontario**  
Tel: +1 905 693 3000

**US – USA, Cleveland**  
Tel: +1 216 896 3000

## Asia Pacific

**AU – Australia, Castle Hill**  
Tel: +61 (0)2-9634 7777

**CN – China, Shanghai**  
Tel: +86 21 2899 5000

**HK – Hong Kong**  
Tel: +852 2428 8008

**IN – India, Mumbai**  
Tel: +91 22 6513 7081-85

**JP – Japan, Tokyo**  
Tel: +81 (0)3 6408 3901

**KR – South Korea, Seoul**  
Tel: +82 2 559 0400

**MY – Malaysia, Shah Alam**  
Tel: +60 3 7849 0800

**NZ – New Zealand, Mt Wellington**  
Tel: +64 9 574 1744

**SG – Singapore**  
Tel: +65 6887 6300

**TH – Thailand, Bangkok**  
Tel: +662 186 7000-99

**TW – Taiwan, Taipei**  
Tel: +886 2 2298 8987

## South America

**AR – Argentina, Buenos Aires**  
Tel: +54 3327 44 4129

**BR – Brazil, Sao Jose dos Campos**  
Tel: +55 800 727 5374

**CL – Chile, Santiago**  
Tel: +56 2 623 1216

**MX – Mexico, Apodaca**  
Tel: +52 81 8156 6000

### EMEA Product Information Centre

Free phone: 00 800 27 27 5374

(from AT, BE, CH, CZ, DE, DK, EE, ES, FI, FR, IE, IL, IS, IT, LU, MT, NL, NO, PL, PT, RU, SE, SK, UK, ZA)

### US Product Information Centre

Toll-free number: 1-800-27 27 537

www.parker.com

