

Flexible Joints for Workover, Completion and Intervention Risers

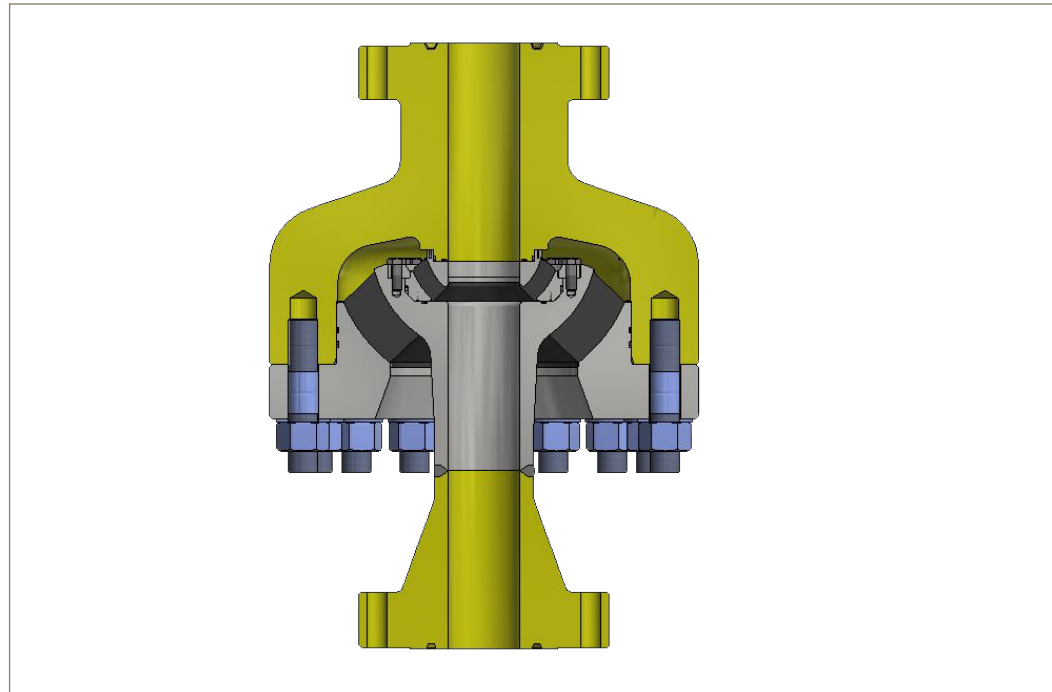

LORD® Flexible Joints can be deployed with Intervention Workover Control Systems (IWOCS) and the associated riser system to accommodate the motion of the intervention/workover vessel relative to the subsea wellhead. A flexible joint can replace a stress joint in this application, supporting the tension in the riser and containing pressure, yet offering a much lower bending stiffness. When used to replace a traditional bottom stress joint, the significantly lower moment imparted to the wellhead allows the operator to perform more workovers per well, thereby extending the life of the field.

Flexible joints can also be deployed at the surface in a riser-based intervention system. The entire flexible joint is just over five feet in height, enabling smaller intervention vessels to operate a top-tensioned riser without a stress joint or a telescopic joint. Using a vessel of opportunity lowers costs compared to performing high-pressure interventions with a drilling rig.



Features and Benefits

- Features unique dual-barrier design
 - Seal bearing provides first barrier and is optimized for high-pressure containment and fluid resistance
 - Load bearing optimized for low rotational stiffness and fatigue strength
 - Load bearing functions as a redundant seal to improve reliability and capability over a single-bearing design
 - Provides a failsafe mechanism unavailable with a stress joint, conventional flexible joint, or other components of the riser system
- Rated to 10,000 psi and hydro-tested to 15,000 psi
- Lower bending stiffness reduces wellhead fatigue, extending field life
- Increased flexibility of riser system widens weather window
- Compact height (just over 5 feet) enables use on smaller intervention vessels
- DNV-certified to API RP17G
- Field-proven: some units have been in service for over a year
- High-pressure high temperature (HPHT) versions available (>350°F)
- We apply aerospace-proven processes and quality systems to Oil & Gas products to ensure each part performs consistently and reliably

10K Completion Workover Riser Flexible Joint

*OTC Spotlight on New Technology™
2018 Award Winner*



ENGINEERING YOUR SUCCESS.

Specification	LORD 10K Workover Riser Flexible Joint
Operating Pressure, max	10,000 psi (69 MPa)
Hydrotest Pressure	15,000 psi (103 MPa)
Operating Temperature	160°F (70°C)
Maximum Temperature Range	14°F (-10°C) to 200°F (90°C)
Internal Diameter	7.22" (18.3 cm)
Maximum Cocking Angle	10°
Axial Load	880 kips (400 tonne)
Axial Stiffness	32,000 kips/in (5600 kN/mm)
Cocking Stiffness @ 160°F (70°C)	20 ft-kip/deg (27 kN-m/deg)
Cocking Stiffness @ 77°F (25°C)	23 ft-kip/deg (31 kN-m/deg)
Torsional Stiffness	23 ft-kip/deg (31 kN-m/deg)



Contact Information:

Parker LORD
Engineered Materials Group
 111 LORD Drive
 Cary, NC 27511-7923
 USA

phone +1 877 ASK LORD (275-5673)

www.lord.com

For a listing of our worldwide
 locations, visit LORD.com



ENGINEERING YOUR SUCCESS.