



# FP3000 Sensors

Catalog MSG33-2353/US



ENGINEERING YOUR SUCCESS.

**Application**

The FP3000 sensor belongs to the Parker family of accessories provided to complement electronic control systems. The FP3000 is a ferrous proximity sensor for mobile hydraulic applications and will sense ferrous objects. The sensor is available with the sense zone on the side (site A) or on the top (site B) of the case. The standard 'site A' version has 'normally open' contacts and twelve inch leads with an attached Deutsch DTM connector. Other versions are available with 'site B' sense zone, 'normally closed' contacts, flying leads or other connector type. To make the sensor suitable for mobile equipment, we have focused upon properties such as reliability and ease of installation.

**Properties**

**Reliability**

The FP3000 has a glass-filled nylon plastic construction for strength and corrosion resistance. The sensor uses non-contact technology, through the use of an internal reed switch, for trouble free operation. The sensor is very robust and able to withstand rugged applications.

**Installation**

The FP3000 is well designed for the mobile hydraulics industry. The connector on the standard version is a sealed Deutsch type designed for automotive use. A sealed connector combined with potted electronics gives the sensor excellent protection for exposed outdoor applications. There are additional FP3000 models with flying leads or other connector types. The mounting holes are extra large for easy alignment. These features provide for easy installation and removal, even in field conditions.

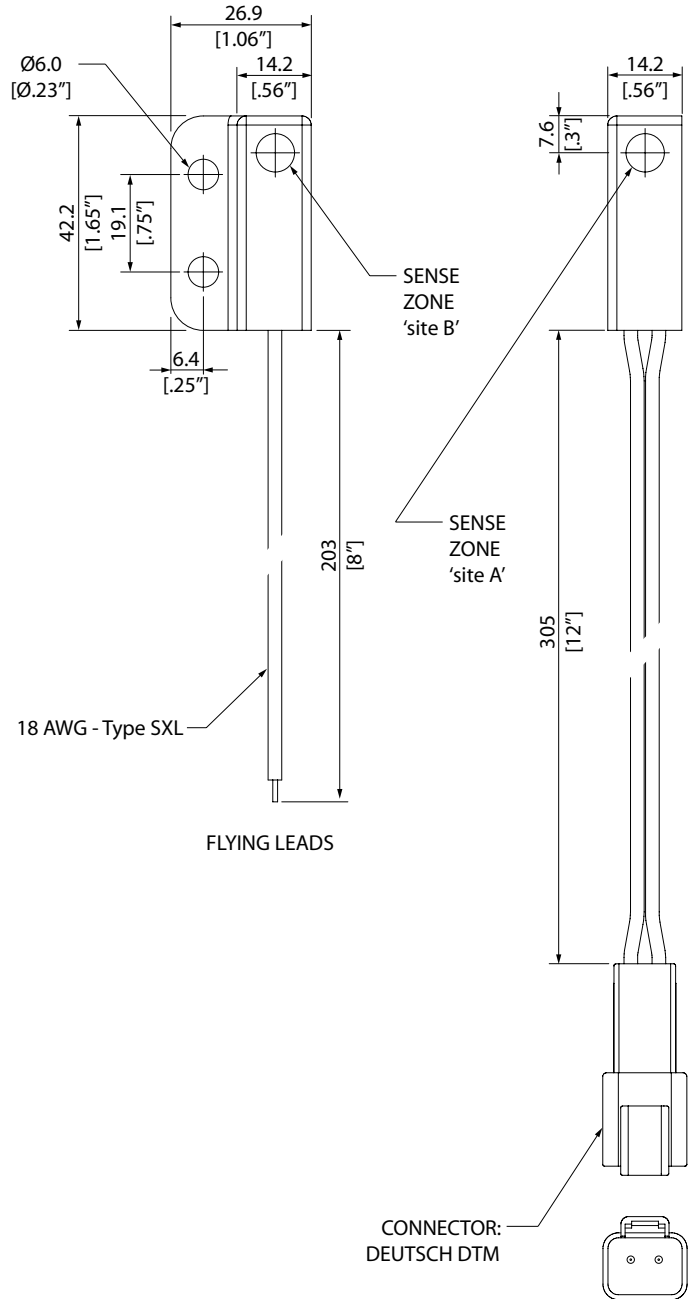

**General**

Weight 26 g  
 Temperature range -40°C to 105°C  
 Operating life 10 million cycles  
 (at logic load)  
 Airgap “make” (signal high) Min 10.2 mm [0.4”]  
 Airgap “break” (signal low) Max 17.8 mm [0.7”]

**Electrical characteristics**

Contact resistance (initial) Max 200 mW  
 Breakdown voltage Min 200 VDC  
 Switching voltage Max 100 VAC/VDC  
 Switching current DC Max 300 mA  
 Bounce time Max 0.4 ms

**Mechanical characteristics**

Switch type <sup>1</sup> Normally open  
 Normally closed  
 Connector <sup>1</sup> Deutsch DTM  
 Flying leads

**Ordering part numbers**

FP3000 NO site A DTM04 01699ECD  
 FP3000 NC site A 8”leads 01062ECD

**Environmental protection**

**Mechanical**

Shock 1m drop  
 Vibration 30 Gs

**Climate**

Sealing IP6K9K

**Chemical environment**

Liquids (resistance) standard automotive

1) Depending on configuration



**WARNING - USER RESPONSIBILITY**

**FAILURE OR IMPROPER SELECTION OR IMPROPER USE OF THE PRODUCTS DESCRIBED HEREIN OR RELATED ITEMS CAN CAUSE DEATH, PERSONAL INJURY AND PROPERTY DAMAGE.**

- This document and other information from Parker-Hannifin Corporation, its subsidiaries and authorized distributors provide product or system options for further investigation by users having technical expertise.
- The user, through its own analysis and testing, is solely responsible for making the final selection of the system and components and assuring that all performance, endurance, maintenance, safety and warning requirements of the application are met. The user must analyze all aspects of the application, follow applicable industry standards, and follow the information concerning the product in the current product catalog and in any other materials provided from Parker or its subsidiaries or authorized distributors.
- To the extent that Parker or its subsidiaries or authorized distributors provide component or system options based upon data or specifications provided by the user, the user is responsible for determining that such data and specifications are suitable and sufficient for all applications and reasonably foreseeable uses of the components or systems.

**OFFER OF SALE**

The items described in this document are hereby offered for sale by Parker-Hannifin Corporation, its subsidiaries or its authorized distributors. This offer and its acceptance are governed by the provisions stated in the detailed “Offer of Sale” available from your Parker representative or at [www.parker.com](http://www.parker.com).



**WARNING - California Proposition 65**

This product can expose you to chemicals including CARBON BLACK (AIRBORNE, UNBOUND PARTICLES OF RESPIRABLE SIZE), STYRENE which is known to the State of California to cause cancer.

For more information go to [www.P65Warnings.ca.gov](http://www.P65Warnings.ca.gov)

# Parker Motion Systems International Sales Offices

## North America

### Motion Systems Group Headquarters

6035 Parkland Boulevard  
Cleveland, OH 44124-4141 USA  
Tel: 216-896-3000  
Fax: 216-896-4031

### Parker Canada Division

160 Chisholm Drive Milton  
Ontario Canada L9T 3G9  
Tel: 905-693-3000  
Fax: 905-876-1958

### Parker Hannifin de México

Industrial Hydraulic Sales  
Eje Uno Norte No.100  
Parque Industrial Toluca 2000  
Toluca, Edo, de Mexico CP 50100  
Tel: 52 722 275 4200  
Fax: 52 722 279 9308

### Parker Hannifin de México

Mobile Hydraulic Sales  
Via de FFCC a Matamoros 730  
Apodaca, NL, de Mexico CP 66600  
Tel: 52 81 8156 6000  
Fax: 52 81 8156 6068

## Europe

### Motion Systems Group Headquarters

La Tuilière 6  
1163 Etoy - Switzerland  
Tel: 41 21 821 8500  
Fax: 41 21 821 8580

## South Africa

### Parker Hannifin Africa Pty Ltd

P.O. Box 1153  
ZA-Kempton Park 1620,  
Republic of South Africa  
Tel: 27 11 961 0700  
Fax: 27 11 392 7213

## Mobile Sales

### Mobile Sales Organization and Global Sales

850 Arthur Avenue  
Elk Grove Village, IL 60007 USA  
Tel: 847-258-6200  
Fax: 847-258-6299

## Industrial Sales

### Central Region

1042 Maple Avenue  
Unit 331  
Lisle, IL 60532 USA  
Tel: 630-964-0796

### Great Lakes Region

6035 Parkland Boulevard  
Cleveland, OH 44124-4141 USA  
Tel: 216-896-2740  
Fax: 866-498-7507

### Gulf Region

20002 Standing Cypress Drive  
Spring, TX 77379 USA  
Tel: 817-473-4431  
Fax: 888-227-9454

### Southwest Region

700 S. 4th Avenue  
Mansfield, TX 76063 USA  
Tel: 817-473-9341  
Fax: 817-473-2680

### Mid Atlantic and Southeast Regions

1225 Old Alpharetta Road  
Suite 290  
Alpharetta, GA 30005 USA  
Tel: 770-619-9767  
Fax: 770-619-9806

### Midwest Region

8145 Lewis Road  
Minneapolis, MN 55427 USA  
Tel: 763-513-3535  
Fax: 763-544-3418

### Northeast Region

P.O. Box 396  
Pine Brook, NJ 07058 USA  
Tel: 973-227-2565  
Fax: 973-227-2467

### Northwest Region

6458 North Basin Avenue  
Portland, OR 97217 USA  
Tel: 503-283-1020  
Fax: 866-611-7308

### Pacific Region

8460 Kass Drive  
Buena Park, CA 90621  
Tel: 714-228-2510  
Fax: 714-228-2511

## Asia Pacific

### Parker Hannifin Shanghai Ltd

280 Yunqiao Road,  
Jin Qiao Export Processing Zone  
Shanghai 201206, China  
Tel: 86 21 2899 5000  
Fax: 86 21 6445 9917

### Parker Hannifin Hong Kong Ltd

8/F, Kin Yip Plaza  
9 Cheung Yee Street  
Cheung Sha Wan, Hong Kong  
Tel: 852 2428 8008  
Fax: 852 2425 6896

### Parker Hannifin Korea Ltd

9F KAMCO Yangjae Tower  
949-3 Dogok1-dong, Gangnam-gu  
Seoul, 135-860, Korea  
Tel: 82 2 559 0400  
Fax: 82 2 556 8187

### Parker Hannifin India Pvt Ltd

Plot No. EL-26, MIDC  
TTC Industrial Area  
Mahape, Navi Mumbai, 400 709 India  
Tel: 91 22 6513 7081  
Fax: 91 22 2768 6841

### Parker Hannifin Australia

Parker Hannifin Pty Ltd.  
9 Carrington Road  
Castle Hill, NSW 2154, Australia  
Tel: 612 9634 7777  
Fax: 612 9842 5111

## Latin America

### Parker Hannifin Ind. e Com. Ltda Hydraulics Division

Av. FredericoRitter, 1100  
94930-000 Cachoeirinha RS, Brazil  
Tel: 55 51 3470 6090  
Fax: 55 51 3470 9281

### Parker Hannifin Argentina S.A.I.C.

Stephenson 2711  
1667-Tortuguitas-Malvinas Argentinas  
Pcia. de Buenos Aires, Argentina  
Tel: 54 3327 44 4129  
Fax: 54 3327 44 4199

### Pan American Division

7400 NW 19th Street, Suite A  
Miami, FL 33126 USA  
Tel: 305-470-8800  
Fax: 305-470-8808

