

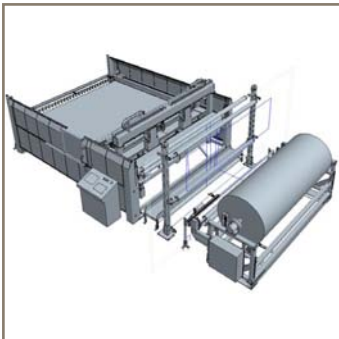

aerospace
 climate control
 electromechanical
 filtration
 fluid & gas handling
 hydraulics
 pneumatics
 process control
 sealing & shielding



HAUSER Automated Cutting Systems

Cross cutting, Length cutting, Stacking

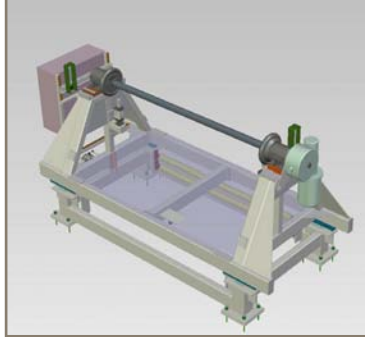

ENGINEERING YOUR SUCCESS.

Cross cutting - Length cutting - stacking:

HAUSER - QLA

HAUSER – the systems house for mechanics, electronics and software.

The advantages:

Complete packages. The core components of our systems are all based on in-house development and production.

Software developed in-house, coupled with decades of know-how in the textile sector, are our guarantees for globally recognised top products.

HAUSER – QLA

offers many options nearly all flexible materials can be efficiently cut, stacked and, if necessary, processed further.

HAUSER – QLA is available as a standard version with numerous options or as application-specific versions.

CE - conformity and ISO quality standard are essential requirements for us.



COMPAX - controller



Reg. Nr. 36 38



Operating console



Linear actuator

Through the combination of our modular components and decades of know-how, we can provide solutions for wide-ranging areas of application.

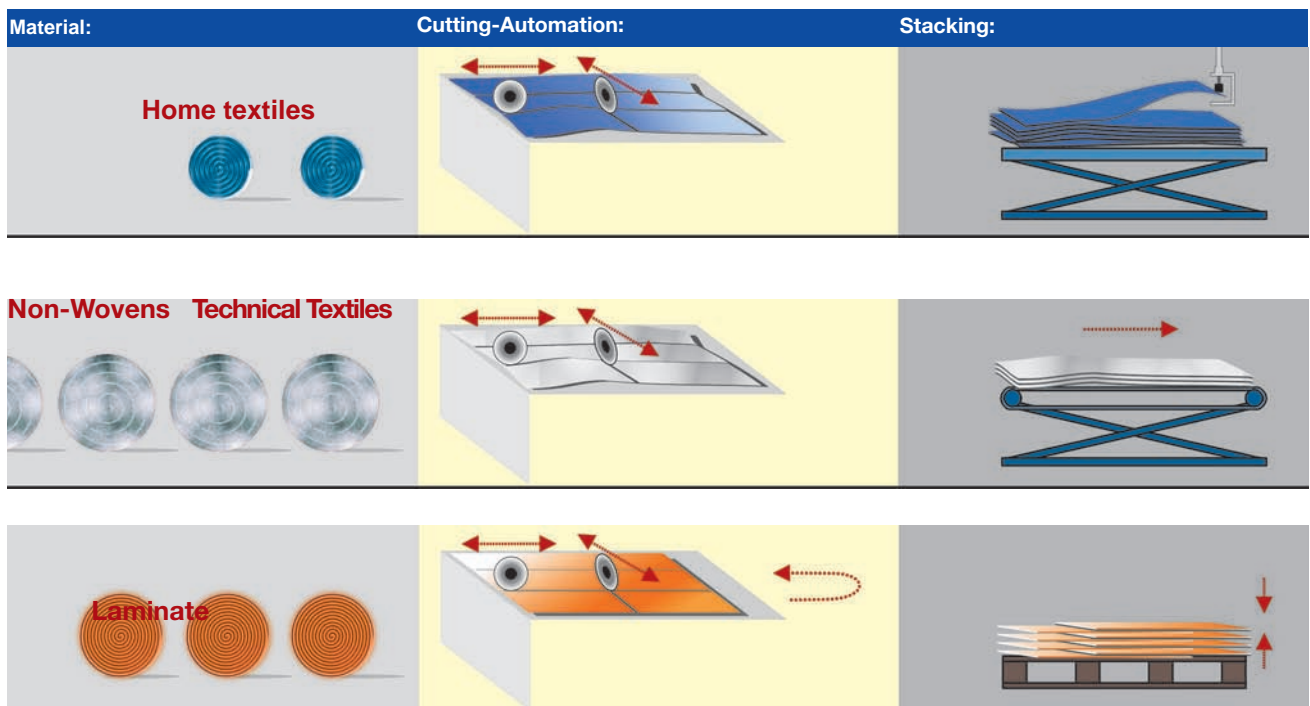

HAUSER



Home Textiles

Non-wovens

Technical textiles

Laminates

Interesting Concept:

Suitable for Many Fields of Application

Flexible through its modular structure and multiple options, HAUSER - QLA is highly suitable for the processing of many materials.

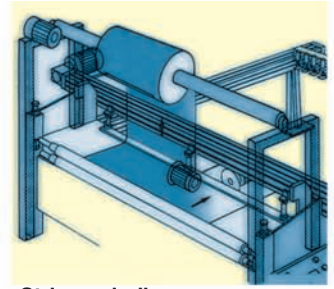

Strip rewinding

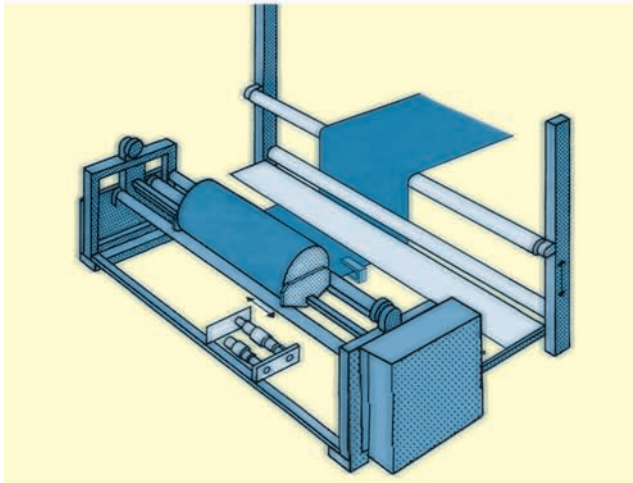

Edge guiding

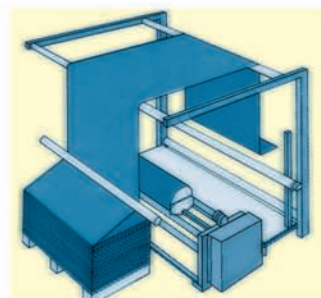

Roll and pallet processing

Continuous feeding for inline application

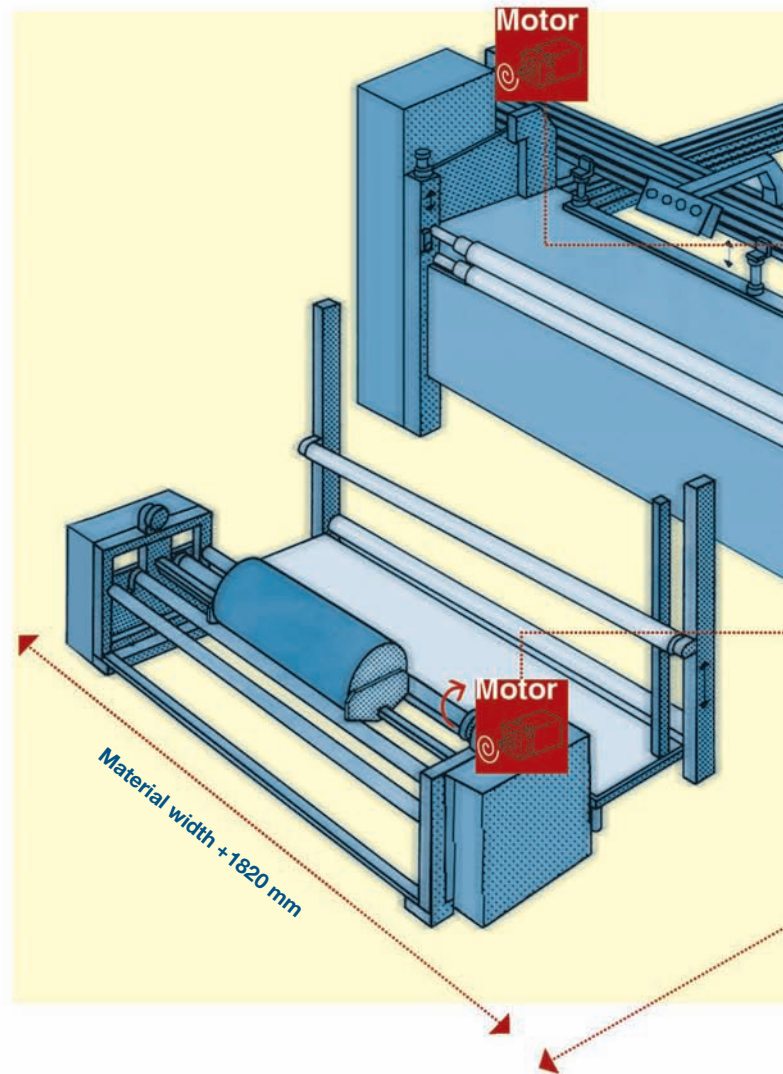
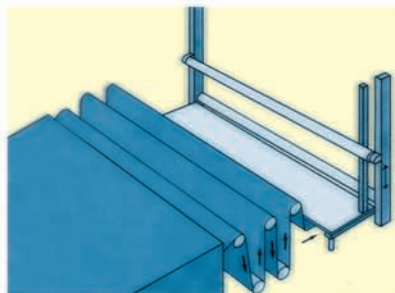

Pallet feeding

A-frame unwinding

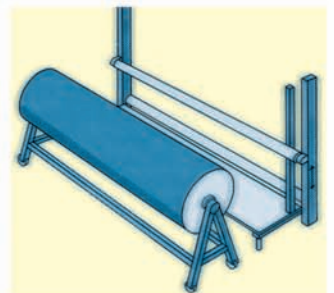
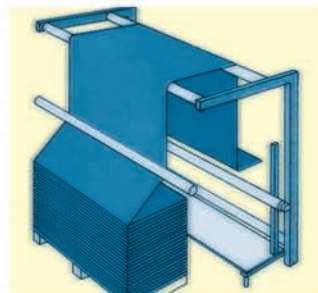

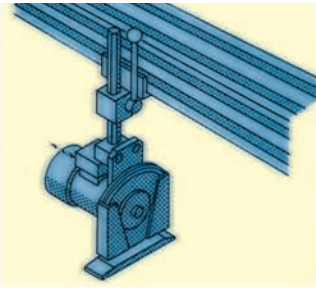

Length cutting unit

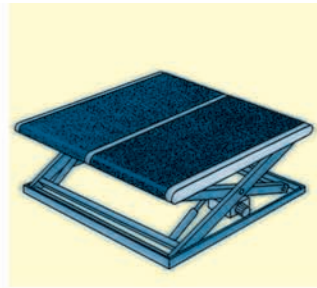

with conveyor belt

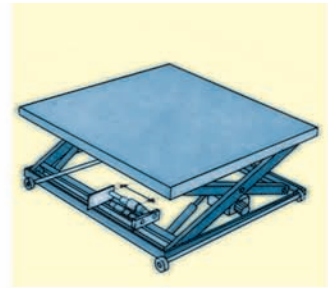

Indexing system

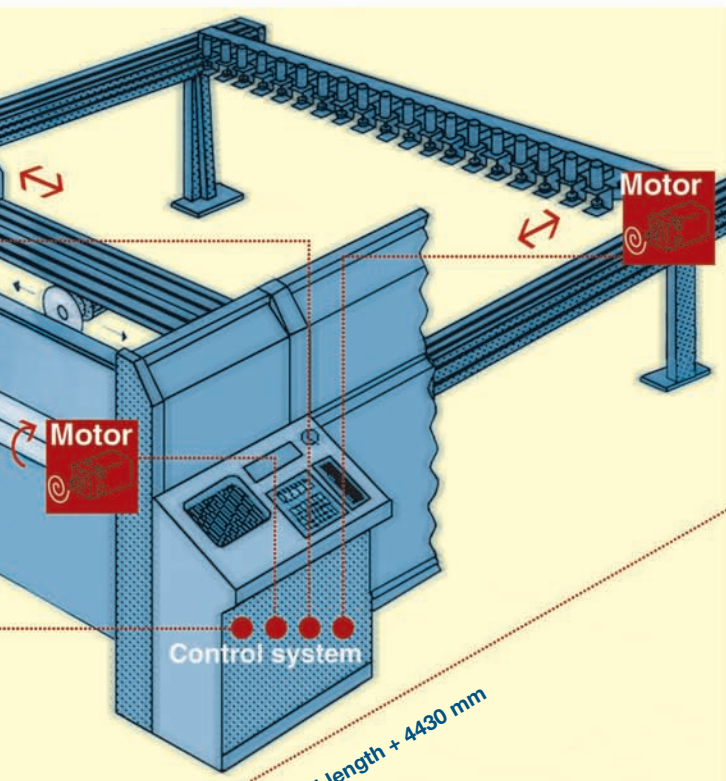

Pull out length + 4430 mm

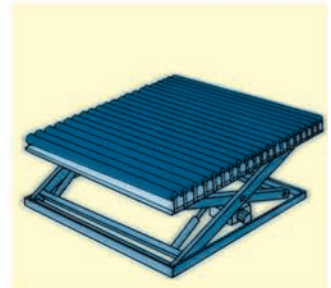

with roller conveyor

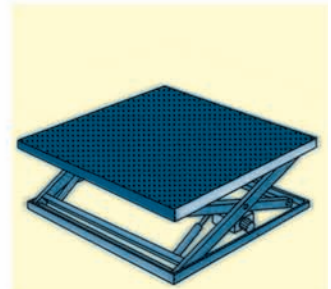

with air floating

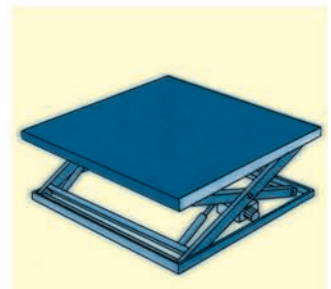

Stacking table with steel platform

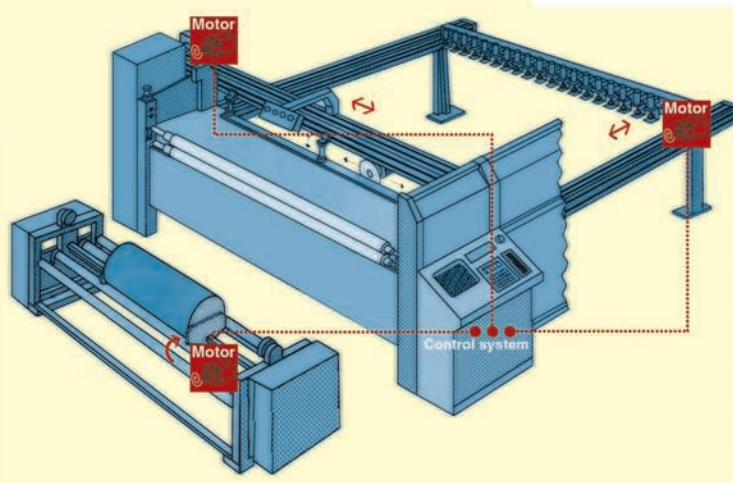

with wooden platform

Application Fields:

Home textiles

Home Textiles

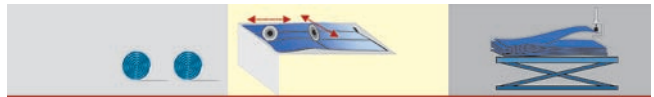

Bed linen

Sheets, fitted sheets, pillow cases, bed covers, ticking, etc.

Towels

Quilted materials

Mattress covers, bedspreads, etc.

Upholstery materials

Furniture, caravans, etc.

Tablecloths

Materials for garden furniture

Couch and chair covers, sunscreens, screen blinds, etc.

Woven materials

for duvets



Double pallet feed with unfolding unit



Pattern repeat

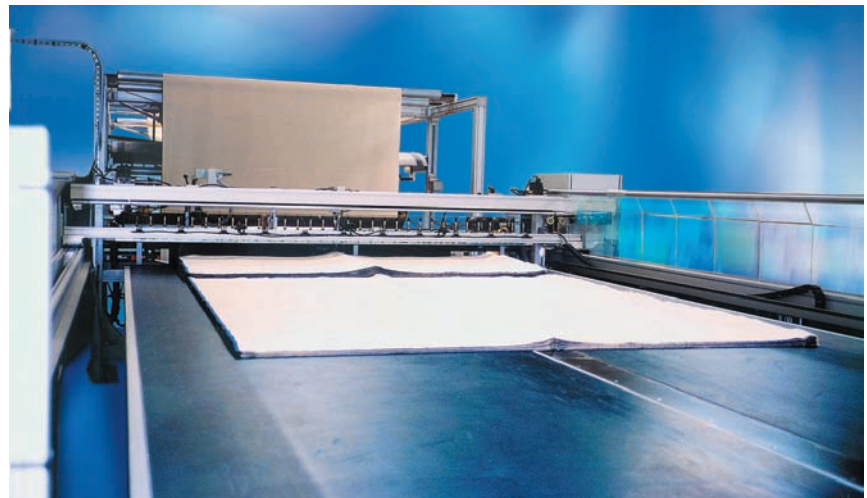

Stacking table with conveyor belt



Cross cutting



Material guiding system

Application Fields:

Non - Wovens

Non-Wovens

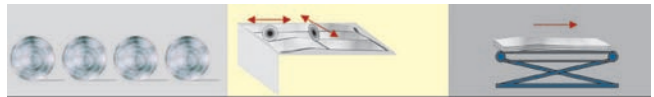

Cleaning cloths

Floor cleaning, cleaning cloths, dusters, etc.

Disposable cloths

Catastrophe protection, railways, air-planes, fire services, camping, etc.

Upholstery industry

Lining materials foams, etc.

Medical disposable products

OP-sheets, OP-covers, cleaning cloths, etc.

Packaging materials

Paper, foils, air cushion foils, PE-foam, etc.

Felts

Mattress protectors, filters, upholstered furniture, recycling materials, etc.

Disposable clothing, protective clothing

Overalls for painting jobs, clean room applications, etc.

Disposable articles

Tablecloths, napkins, tray liners, etc

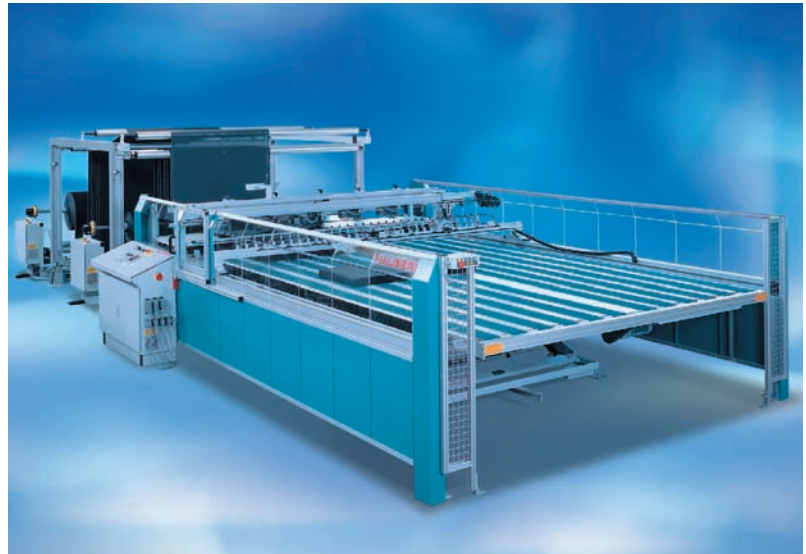

Standard QLA

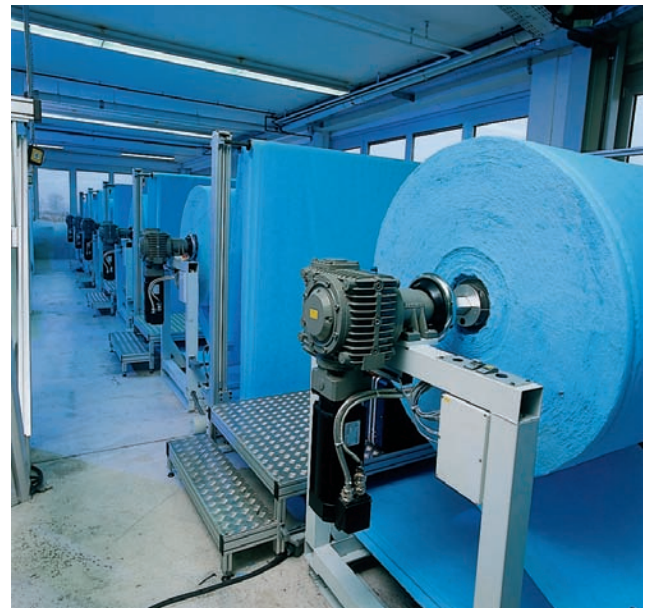

Multiple unwinding



Length cutting and extraction



Cutting knife shaft

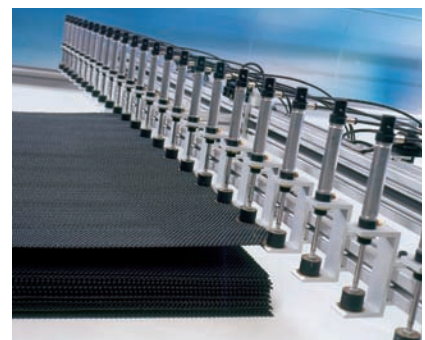

Stacking of cuts

Application Fields:

Technical Textiles

Big Bags

Pharmaceuticals, foodstuffs, chemistry, construction, etc.

Air Bags

Automotive supply industry

Sun protection

Construction projects, caravans, etc.

Compound materials

Air and space travel, automotive parts, technical light construction

Filter materials

Filter bags for heavy industry, compressors, emergency power aggregates, turbines, etc.

Rubber materials

Heavy layer materials for the automotive industry, car rugs, vehicle linings, seals, etc.

Laminated, coated materials

Roof facings, door facings, tent materials, sport articles, anti-glide materials, etc.

Foils

Advertising, overlays, bindings, shower curtains, tarpaulins, etc.

Honeycomb Material

Airplane construction, construction industry, automotive manufacturing, etc.

Impregnated materials

Shoe upper materials, fire-resistant materials

Floor coverings

Automotive industry, foot mats, etc.

Technical Textiles

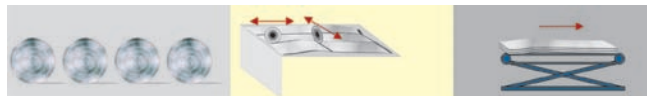

Customized solutions

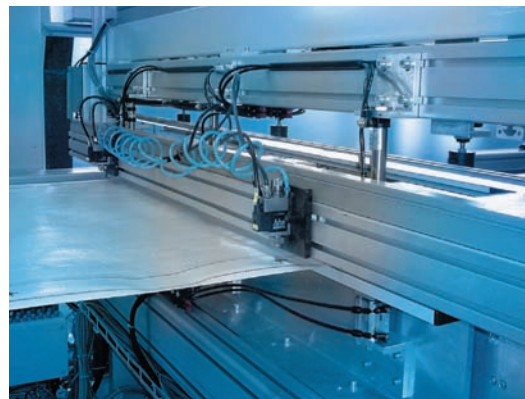

Marking during movement

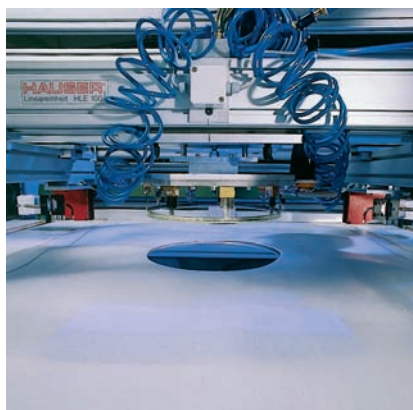

Thermal cutting



Cutting with ultrasonic

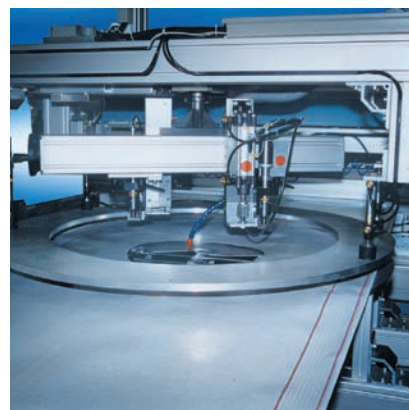

Cutting with ultrasonic

Application Fields: Laminates

Construction laminate

Floor covering laminates,
Laminates for the construction industry

Industry laminates

Printed circuit boards, "pre-pregs",
copper foils, etc.

Laminates

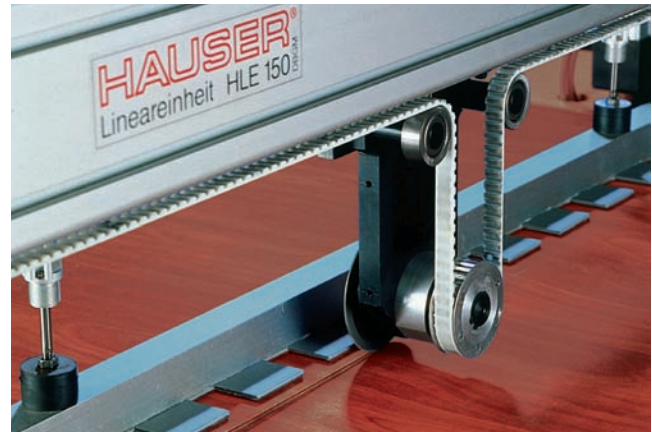
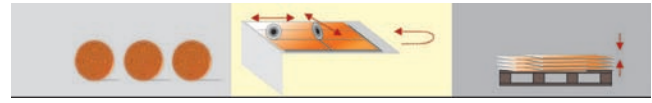

Cross cutting unit

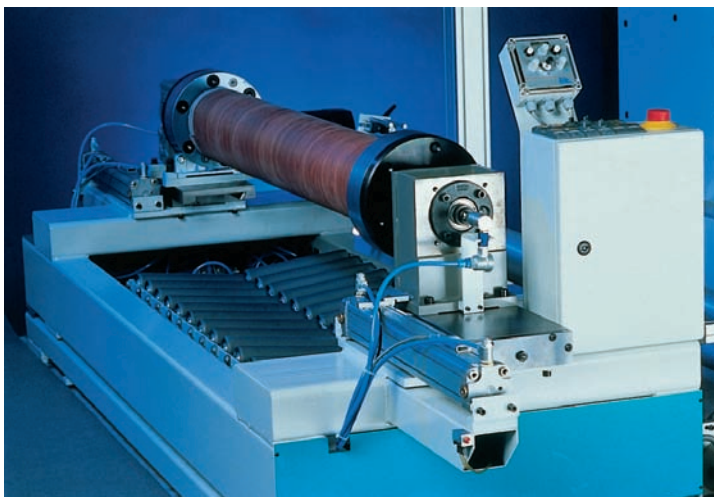

Shaftless unwinder

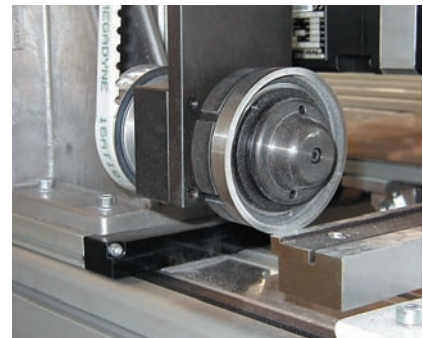

Cutting bar



Flipping unit



Offset stack



Ultrasonic track - welding



Multiple unwinding

Software – Programming – Operation: Complete solution from HAUSER

The HAUSER software team produces both standard and customer-specific software solutions. You can achieve the perfect cuts with the know-how of our programmers, based on decades of experience and continual improvements in learning.

Optional monitor for visualisation of complex multiple set inputs



Standard input panels



Programming of different, customer-specific solutions in-house

HAUSER is a company in the Parker Hannifin Group. This partnership in the "Automation" field has proved itself across the world. We are part of a large family and profit from the strength of a successful corporation. Our clients profit directly from the intensive know-how transfer within the corporation. In order to be able to keep abreast of the globalization trend it is important to have a world-wide presence and to be competent locally.

HAUSER: We keep moving where others stand still.

HAUSER can provide all the services you require. Extensive consulting, individual project planning, design, manufacturing and commissioning. Our service is fast when you need it. We won't let you down: Experienced experts are always on hand to help, giving you the secure feeling that you have made the correct investment decision.

Project planning

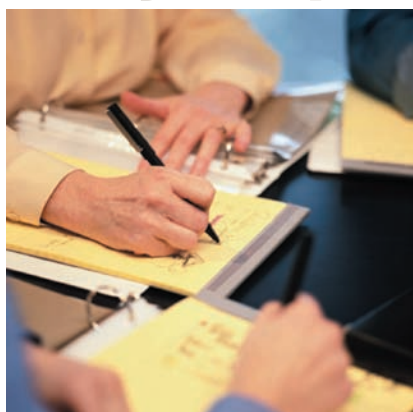

Project planning: Experienced experts are with you all the way. Extensive consulting, individual project planning – gives you the security you need.

Design



Design: Our engineers' know-how and modern development tools make it possible to develop individual and mature system solutions.

HAUSER – for a good cut!

Full Service for your Cutting - Automate

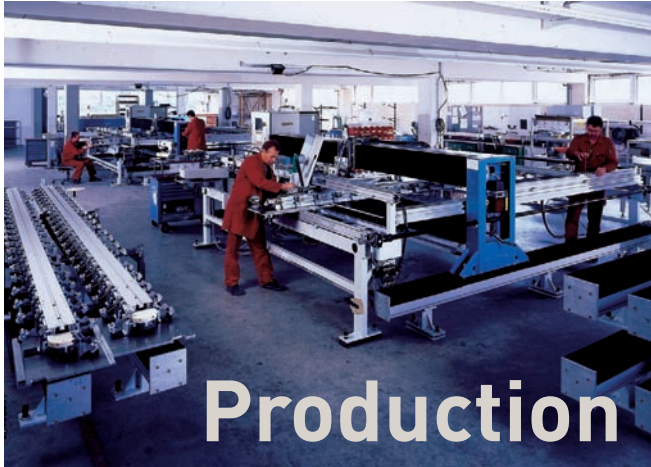

Production:

„Made in Germany“ – well-trained specialists manufacture highly-developed, durable, high-tech products.

PARKER Hannifin EME
Located in Offenburg.



Commissioning

Our specialists will put your product into operation.

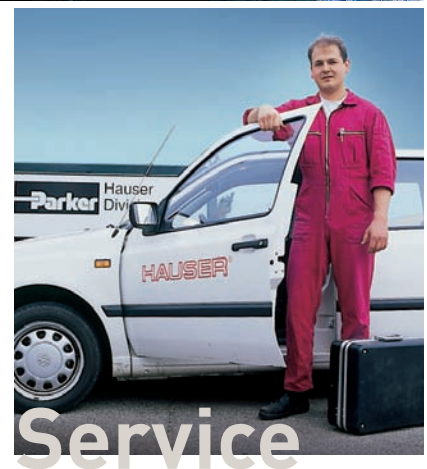

Local service:

Quick, competent and reliable – whenever you need us. At HAUSER, service is not just a sales argument..

We are a powerful partner –
talk to us!

Your contacts

You can take advantage of our experience and the know-how of our specialists. Profit from the benefits of our innovative technology to obtain a cost-effective and user-oriented solution. Wherever tailor-made and custom-built automation services are required, you will find that our expertise makes us the right people to talk to.

HAUSER Sales - Automated Cutting Systems

Tel.: +49 (0)7 81 / 5 09-44 50 to 4455
Fax: +49 (0)7 81 / 5 09-984 56
e-mail: textilestystems@parker.com

Would you like more information?
Just ask for our brochures.
Or simply give us a call and arrange an appointment

