



INJECTION MOLDED PLASTIC SOLUTIONS

Engineered Custom Solutions for EMI Shielding and Weight Reduction Applications

PARKER CHOMERICS CAPABILITIES

Plastic Injection Molding

- PREMIER® and other filled electrically conductive plastics
- Traditional thermoplastics
- EMI and cosmetic coating services
- EMI and environmental gasket integration
- Assembly, pad printing, hot stamping, welding and heat staking
- Insert molding, two-shot molding and overmolding capability

Thermal Management & Control

- Thermally conductive gap filler pads
- Dispensed thermal gap fillers
- Silicone-free thermal pads
- Phase-change materials (PCM)

- Polymer solder hybrids (PSH)
- Dispensable thermal compounds
- Thermal grease and gels
- Insulator pads
- Thin flexible heat spreaders
- Custom integrated thermal/EMI assemblies

EMI Shielding & Compliance

- Conductive elastomers – molded, extruded, and form-in-place (FIP)
- Conductive foam based gaskets – fabric-over-foam and z-axis foam
- Conductive compounds – adhesives, sealants and caulks
- RF and thermal/RF absorbing materials
- EMI shielding plastics and injection

molding services

- Coatings – direct metallization and conductive paints
- Metal gaskets – Springfingers, metal mesh and combination gaskets
- Foil laminates and conductive tapes
- EMI shielding vents – commercial and military honeycomb vents
- Shielded optical windows
- Cable shielding – ferrites and heat-shrink tubing/wire mesh tape/zippered cable shielding
- Compliance and safety test services

Metal Housings

- Machined
- Stampings
- Die castings

About Parker Hannifin Corporation

With annual sales of \$20 billion for fiscal year 2025, Parker Hannifin is the world's leading diversified manufacturer of motion and control technologies and systems, providing precision-engineered solutions for a wide variety of commercial, mobile, industrial and aerospace markets.

The company's products are vital to virtually everything that moves or requires control, including the manufacture and processing of raw materials, durable goods, infrastructure development and all forms of transport. Traded on the New York Stock Exchange under the symbol "PH," Parker is strategically diversified, value-driven and well positioned for global growth as the industry consolidator and supplier of choice.

PARKER CHOMERICS PLASTICS SOLUTIONS

Some of the today's most innovative products depend on highly advanced materials and methods of manufacturing. Many of these materials and methods are well established in some markets; however new markets are being transformed every day with the introduction of more advanced technology. Many new successful products have achieved this high level of innovation through the use of advanced engineered resins and injection molding technology. This brochure is intended to assist engineers and decision makers on the nature of these possibilities, and how Parker Chomerics is uniquely capable of meeting these demanding needs.

Engineering Advanced Plastic Solutions

The use of highly engineered resins and its resulting "Metal Replacement Technology" requires technical familiarity with both plastics and metals technologies. Parker Chomerics engineers are experienced with the requirements needed when designing a part for metal replacement. We can assist in guiding you through a thermoplastic solution that will successfully meet the performance requirements of the metal parts they are designed to replace, and in some cases even surpass the original design.



Integrating Multiple Metal Parts into a Singular Plastic Component

Two of the most significant benefits derived from injection molding technology are flexibility and simplification for manufacturability, both leading to dramatic cost reductions while retaining or enhancing product performance.

An assembly of multiple metal parts for example, may lend itself to be re-engineered as one plastic component. Instead of multiple metal parts that may require machining, assembly or painting. Our team has enabled customers to achieve a single, lightweight, cost-effective replacement package, quite often with unparalleled cost savings.

Markets

Parker Chomerics Plastics product markets include:

- Automotive/Transportation
Accumulator pistons, plastic cylinder head covers, lumbar support, vent caps, wiper pivot housings...
- Telecom/IT
infrastructure, power supply, routers, servers...
- Consumer/Appliance
Home security, hand tools
- Industrial/Safety/Electronics
- Military/Aerospace
- Industrial
- Medical

PARKER CHOMERICS ENGINEERING COMMITMENT

Since its very creation in 1946, Webster Plastics focused on innovation and total commitment to the customer. Parker Chomerics continued that legacy when it acquired Webster in 2005. The company has never outgrown the premise that has, for over eighty years, brought success to our customers, one innovative engineering solution at a time.

Today, Parker Chomerics' Plastics provides premier plastics injection molding and engineering support capabilities.

Our client roster ranges from giant global mass-producers, to short-run specialized product manufacturers. All are equally demanding and all are afforded the highest quality services at all times.

It is our resolve to explore and to innovate that makes Parker Chomerics' Plastics a very unique company, a company that stands above the rest.



Engineered Custom Injection Molded Plastic Solutions

Engineering

- Single Point Authority
- Concept to Production
- Design Consultation
- Mold Flow Analysis
- Metal to Plastic Conversion
- Parts Consolidation
- Material Selection
- Design for Manufacturing/Assembly
- Advanced Quality – FMEA/DOE

Manufacturing

- Advanced Statistical Process Control Machines
- 22 – 1000 Ton Capacity
- 24 hour operation
- Shot size: 1 gram to 10 lbs. (4.54 kg)
- In-House Tool Room, Debug & Repair
- Cellular-Organized Manufacturing
- Automation/Robotic Systems
- Closed-Loop Material Control
- Complete Assembly Operations
- Two-Shot Molding
- Insert Molding
- TS 16949
- ISO and advanced certifications

PARKER CHOMERICS ENGINEERING COMMITMENT

Proven Record of Reducing Our Customer's Total Cost of Ownership

- Innovative Engineering and Manufacturing Solutions
- Real-time Process Monitoring
- State-of-the-Art Closed Loop Material Delivery System

Engineering Services

- Design Consultation
- Solid Model Geometry
- Mold Flow Analysis
- Program Management
- Advance Product Quality Planning
- Global Supply Chain
- Limited and High Production
- Internal Debug Capability
- Process & Inspection
- Process Parameters by DOE
- Engineered Material Experience
- Testing
- Formulation and Compounding
- PPAP and PSO Documentation

Design for Manufacturing/ Assembly Expertise

We partner with our customer to develop a robust injection moldable product design.

Tooling Strategy

After developing a robust design we work with our tooling suppliers to get accurate quotes tailored to the customer's program requirements.

Production Strategy

In support of the tooling strategy, we review the program requirements to evaluate the necessary manufacturing equipment to offer the customer the most cost competitive and lean work cell.

parker.com/chomerics

Core Team For Every Project

All programs are managed by following the APQP process. This process ensures proper management of all quality, tooling, ancillary equipment, facility requirements, raw materials, and customer specified requirements.

The core team consists of a project engineer (customer's single point of contact), manufacturing engineer, and advanced quality engineer. In support of this team are members from Production Quality, Tool Room, Manufacturing, Facilities, and Lean Manufacturing teams.

Throughout the development cycle many procedures are followed to ensure the most capable manufacturing process.

- Scientific Injection Molding Process Establishment
- Dimensional Layouts
- Tool steel debug based on robust molding process
- Capability Studies
- Process Monitoring Control Limits

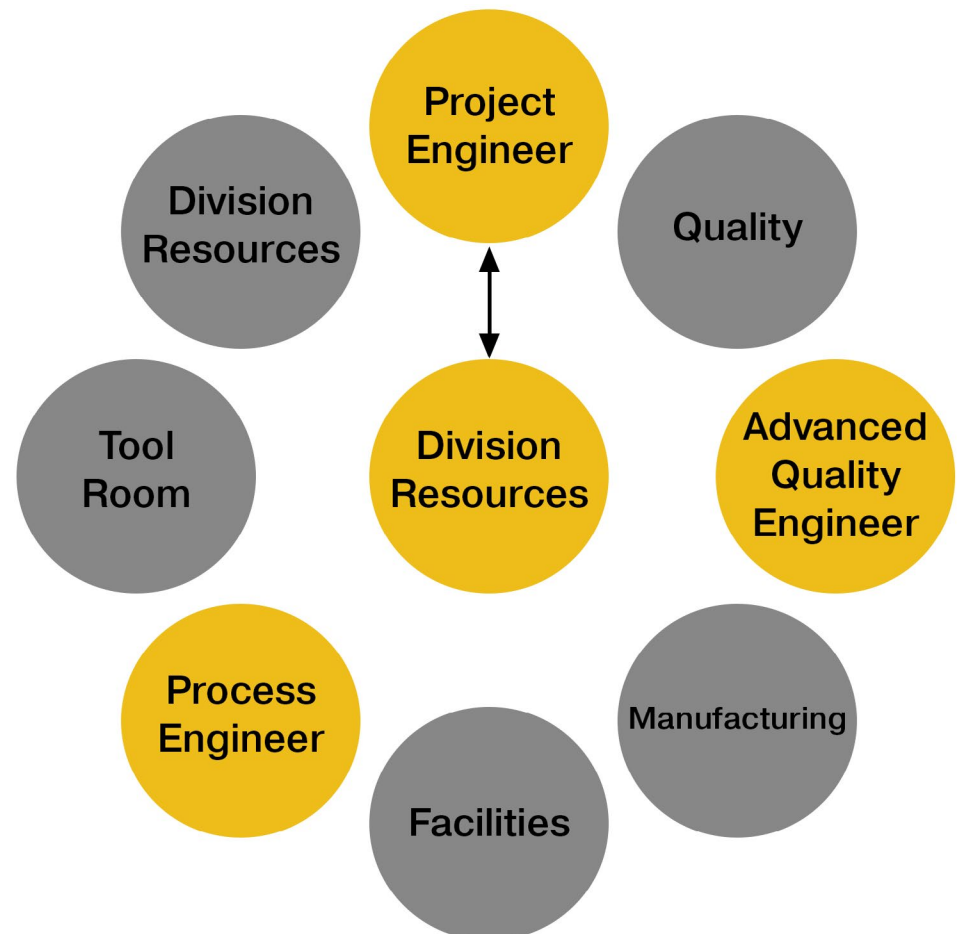

PARKER CHOMERICS ENGINEERING PARTNERSHIP

Mold Flow Analysis

Mold flow analysis allows us to create simulated 3-D material flow patterns for injection molded parts.

We can graphically and statistically visualize flow rates, pressure and temperature values throughout the entire part before it is molded.

This invaluable tool helps us adjust the molding process by relocating entry gates and compensating for variable pressures or cooling rates that can cause warpage or uneven shrinkage. It also alerts us if a plastic part design has to be modified to assure the part's strength and integrity. The result is less waste, faster development and more efficient production rates.

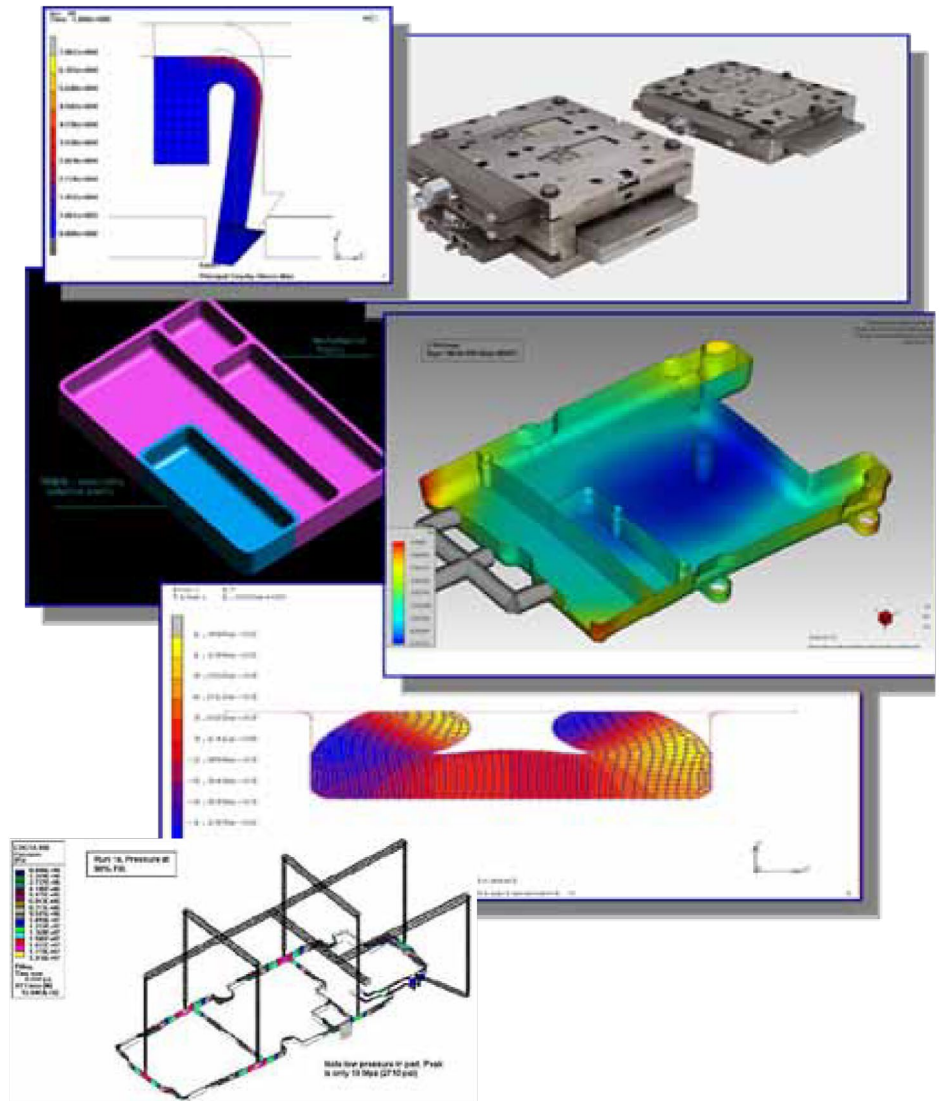

Engineers can simulate actual molding processes. The analysis is used to design the optimum part and mold configuration.

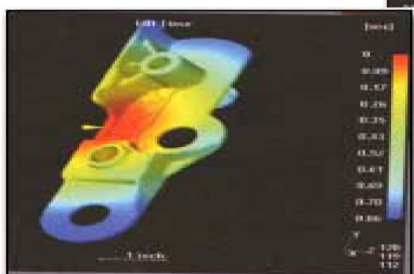
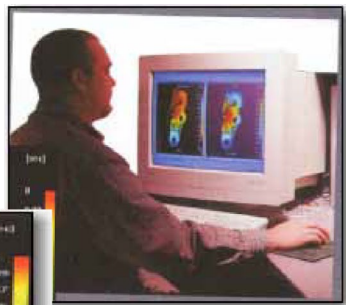

Simulated mold flow image shows areas of varying temperatures and pressures, helping engineers design the most efficient mold.

PARKER CHOMERICS HIGH-EFFICIENCY MANUFACTURING CAPABILITIES

Our manufacturing capability is enhanced by the following:

- Purpose built facility designed for Injection molding
- Closed Loop Central material feed system for lean manufacturing
- Five 40,000 LB Silos for high volume material storage
- Integrated Real-Time Process Monitoring
- Equipment Predictive / Preventive Maintenance tied to Process Monitoring
- Comprehensive Machine size range – 22 ton to 1,000 ton
- Cellular Manufacturing with automated assembly and testing (where required)
- Value Add – Pad printing, vibration / ultrasonic welding, testing, hot stamping, heat staking, press fitting, assembly



Advanced Closed-Loop Materials Delivery System

Parker Chomerics Plastics has the resources in place to assure strict adherence to your specific material requirements.

Our centralized raw material processing system cleans, conditions and automatically delivers precise blends of raw material to each injection molding machine.

A super-efficient micro filter system traps dust and fine particles and measures the proper proportion of regrind allowable.

This centralized delivery system assures the raw material is consistently introduced in its optimum condition for the best possible results in the injection molding process.

When we mold high-tolerance,

high-performance parts, you can be certain they are molded of 100% high-performance thermoplastics, 100% of the time.

Central Material Feed System

- Material delivery direct from Silo, Barrel, or Dryer
- 22 dryers with capacity from <100 to 1,200 pounds
- Closed loop management of regrind

Extensive Molding Capabilities

- Injection Molding Presses: > 40
- Clamp Forces: 22 to 1000 Ton
- Part Weights: 1 gm to 10 lbs
- Methods: Insert, Two-shot, and Vertical Molding

Process 300 Grades of Resin Including:

- PEEK
- PEI-Ultem
- PPA-Amodel
- PPS-Ryton/Fortron
- PAA-Ixef
- LCP
- POM-Acetals
- PA-Nylons
- Premier
- PC, PC/ABS, HDPE, HIPS, etc.

VALUE-ADDED OPERATIONS



Ultrasonic welding

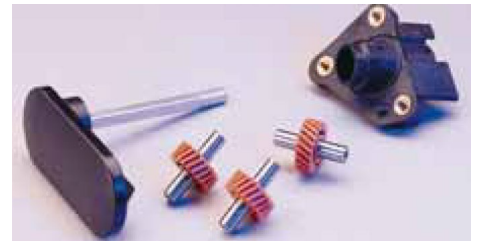

Overmolding



Pad printing



Vibration welding, Heat staking

PARKER CHOMERICS MONITORING, QUALITY, AND SPECIAL CAPABILITIES

24/7 Real-time Monitoring of Every Shot

- Immediate notification of a potential problem.
- Exceeding control limits results in alarms and automatic parts diversion via reversing conveyors
- Control limits developed with DOE's during qualification stage
- Measures process parameters, not finished parts
- Six sigma quality is achievable
- Used as predictive maintenance tool for processing equipment

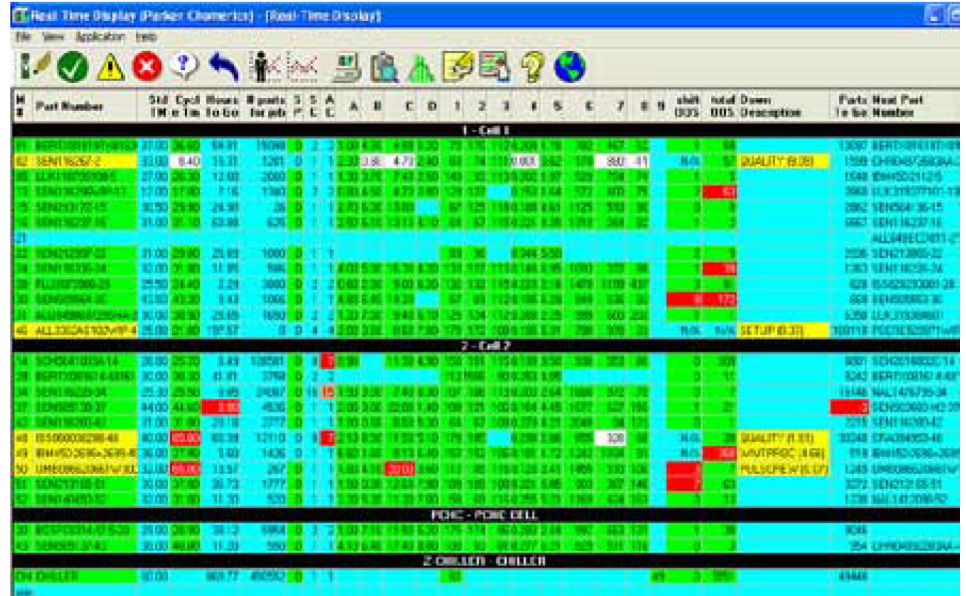

Quality

- TS16949 / ISO 9001 quality system
- ISO 14001
- Automatic part separation tied into Integrated Process Monitoring
- Tool PM initiated by automated cycle count

Special Capabilities

Large Parts Manufacturing

Molding large parts presents a unique challenge. Our 1000 ton closed-loop injection molding machines are equipped with the latest state-of-the-art computerized process control systems, including all necessary peripheral accessories. In addition, to assure an uncontaminated supply of raw material, we use a closed-loop material handling system.

Two Shot Molding

Two-shot molding allows industrial designers a wider latitude in introducing more features and improving consumer appeal. Multiple materials are molded in one operation to provide not only form and function, but efficiency and economy to consumer, medical, automotive, office automation and telecommunications products. An unlimited combination of materials and colors can be used, for a wide variety of effects including translucent materials in backlight applications.



COMPETITIVE ADVANTAGE GUIDE

Competition	Advantages of Plastic Injection Molding
Die-casting	<ul style="list-style-type: none"> Significantly lower tool investment over life of program Improved dimensional capability Reduce/Eliminate secondary operation Weight reduction
Stamped/Formed Metal	<ul style="list-style-type: none"> Increased design freedom Increased material choices Chemical/Corrosion resistance Integration of components
Machined	<ul style="list-style-type: none"> Reduced Piece Cost Reduced raw material waste Shorter production lead time Chemical/Corrosion resistance Weight reduction
Multi Part Assembly	<ul style="list-style-type: none"> Net molded parts Reduce/Eliminate secondary operations Increased productivity Integration of components Improved quality
Plastic Components with EMI Requirements	<ul style="list-style-type: none"> Reduce/Eliminate secondary operations (Paint, Plating, Metalizing, Laminates...) Reduced piece cost No risk of delaminating Supply chain reduction
Custom Molders	<ul style="list-style-type: none"> Integrated Process Monitoring Closed Loop Material Feed System Material Experience Machine size range Complete engineering support

GENERAL MATERIAL DATA

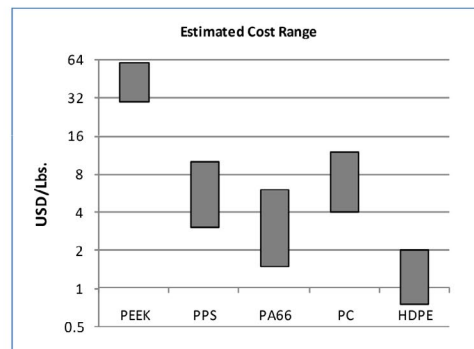
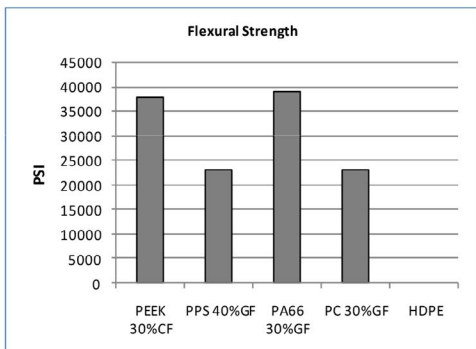
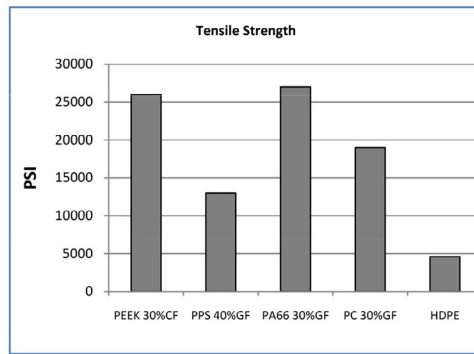
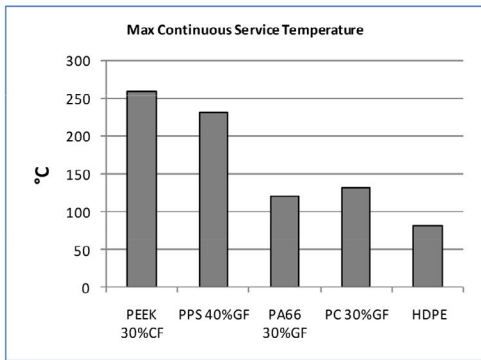

CASE STUDY #1

Transmission Solution

Situation	Customer's Unmet Needs	Solution/Benefits
<p>Product</p> <ul style="list-style-type: none"> Accumulator Piston <p>Customer's competition</p> <ul style="list-style-type: none"> Die cast, with secondary machined aluminum <p>Application Data</p> <ul style="list-style-type: none"> 300°F Transmission Fluid 122 psi on spring side 70 to 420 psi on face side 	<ul style="list-style-type: none"> Low Cost Labor intensive assembly method End of line test failures due to improper installation and cut D-rings Insufficient flow of oil 	<p>Parker Chomerics Plastics Solution:</p> <ul style="list-style-type: none"> Eliminate secondary machining operations by producing a net shaped plastic part. In-line automated assembly of Parker D-ring onto piston. Automated 100% inspection of installed D-ring for size and proper installation. Enhanced oil flow channels <p>Quantifiable Customer Benefits:</p> <ul style="list-style-type: none"> Reduce total cost of ownership for customer Elimination of end of line testing failures Improved performance

Die Cast Design



Application Evaluation

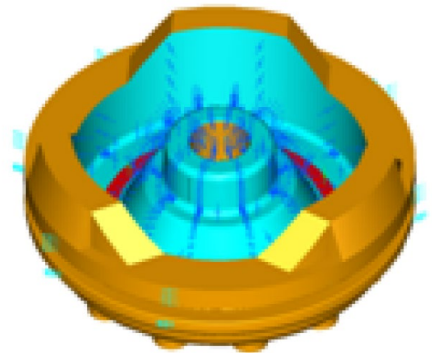

Finite Element Analysis

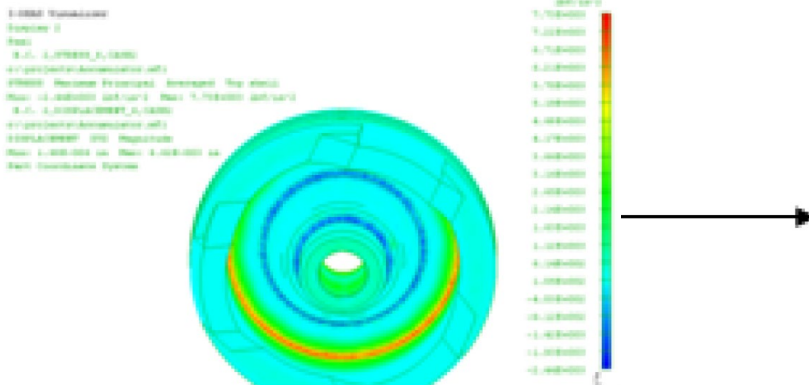

Current Plastic Design



CASE STUDY #2

Premier Team — Innovative Solutions

Situation	Customer's Unmet Needs	Solution/Benefits
<p>Product</p> <ul style="list-style-type: none"> • 7 & 4-Port Optical faceplate <p>Current State</p> <ul style="list-style-type: none"> • 6 metal pieces, welded together with extensive skilled labor costs and quality control requirements • Labor-intensive assembly <p>Application Data</p> <ul style="list-style-type: none"> • EMI shielding • Serviceability requirements • RoHS Compliant 	<ul style="list-style-type: none"> • Low Cost • Labor intensive assembly method • Reduce purchasing and inventory costs for multiple parts • Reduce lead-time, system build-to-ship 	<p>Parker Chomerics Plastics Solution:</p> <ul style="list-style-type: none"> • Consolidated 6 metal pieces into 1 thermoplastic molded part <p>Quantifiable Customer Benefits:</p> <ul style="list-style-type: none"> • Reduced component cost • Eliminated faceplate assembly labor • Reduced inventory/purchase/handling costs • Shorter lead-time, system build-to-ship • Premier solution is significant cost reduction vs. sheet metal & welded assembly

Multiple Metal Components, Welded Together

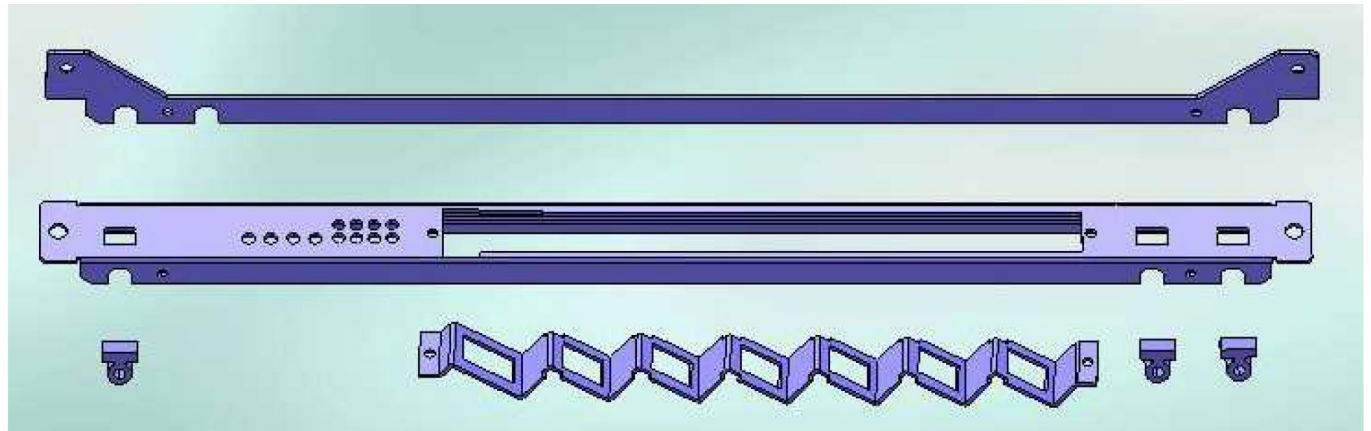

Single Shot, Molded Part

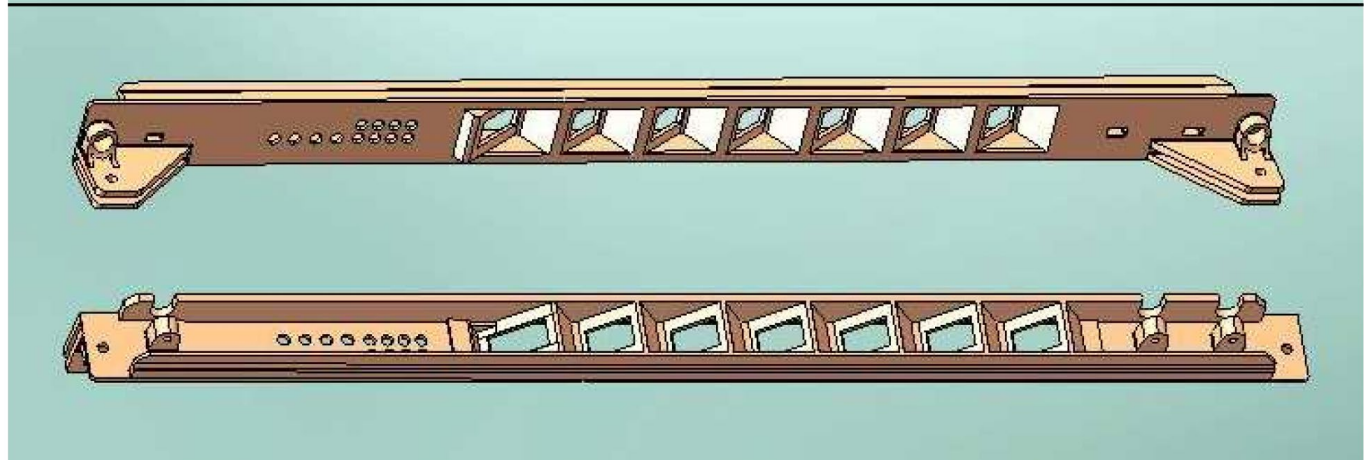

CASE STUDY #3

Injection Molding Solution

Situation	Customer's Unmet Needs	Solution/Benefits
<p>Product</p> <ul style="list-style-type: none"> • Telematics Housing <p>Current State</p> <ul style="list-style-type: none"> • Thick walled diecasting • Secondary machining for threads and side pulls <p>Application Data</p> <ul style="list-style-type: none"> • EMI Shielding • Thermal management • Secure, mount, protect electronics 	<ul style="list-style-type: none"> • Improve economics, while providing: <ul style="list-style-type: none"> » Appropriate levels of EMI Shielding » Appropriate levels of thermal management » Weight reduction • Meet aggressive price targets 	<p>Parker Chomerics Plastics Solution:</p> <ul style="list-style-type: none"> • Replace die-cast part with an injection molded plastic part • Resin based solution, or secondary metalizing process (vacuum metalized, plating, or painting), to achieve advanced EMI Shield performance • Thermal management achieved by overmolded integrated heat sinks <p>Quantifiable Customer Benefits:</p> <ul style="list-style-type: none"> • Reduce total cost of ownership for customer • Reduction in lead-time

Die-Cast with Secondary Operations

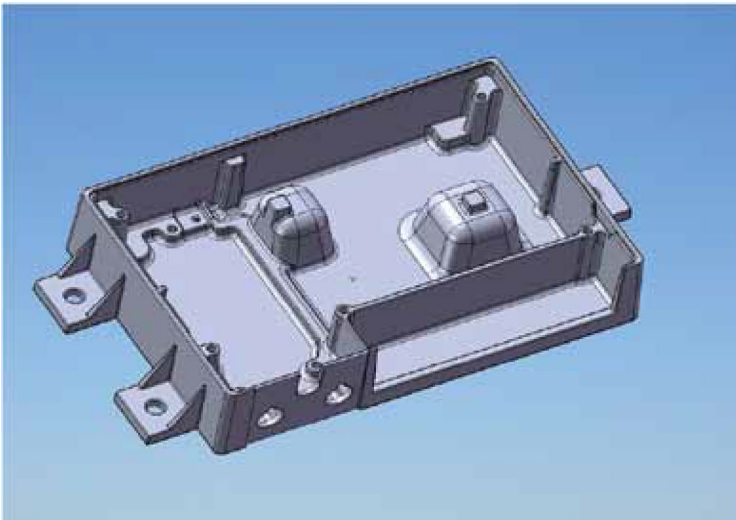

Injection Molded with Integrated Heat Sinks

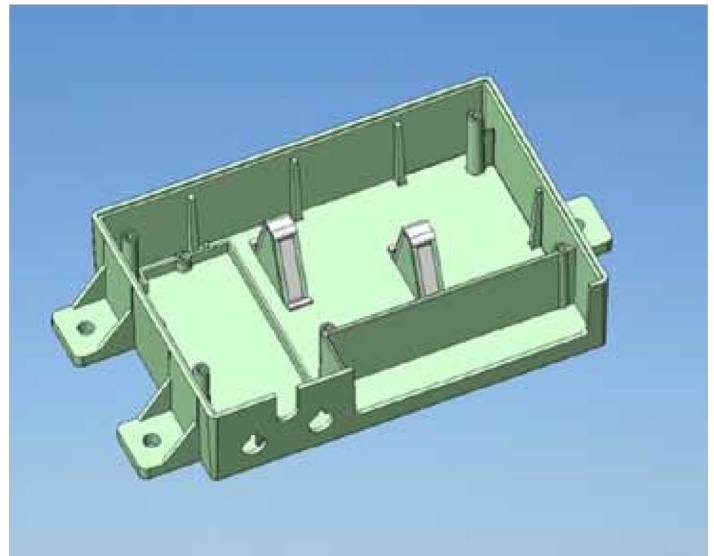

CASE STUDY #4

Cost and Lead-time Reduction of Manufacturing Process

Situation	Customer's Unmet Needs	Solution/Benefits
<p>Product</p> <ul style="list-style-type: none"> Metering valve for fluids <p>Current State</p> <ul style="list-style-type: none"> 100% Machined PVC from large pieces of rod stock <p>Application Data</p> <ul style="list-style-type: none"> Chemically Resistant High Mechanical Strength 	<ul style="list-style-type: none"> Meet significant cost reduction targets Improve manufacturing lead time Improve overall part quality –based on the consolidation of several operations into few Reduce machining waste material 	<p>Parker Chomerics Plastics Solution:</p> <ul style="list-style-type: none"> Redesign part to core out non-functional areas Build a low-cost mold Selected a molding material that meets requirements <p>Quantifiable Customer Benefits:</p> <ul style="list-style-type: none"> Reduced part weight Reduced part overall cost Shorter lead times Better part quality

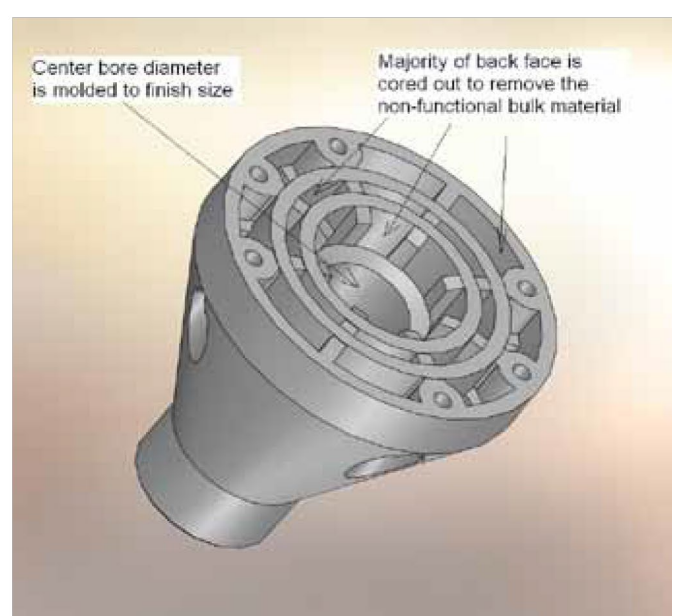
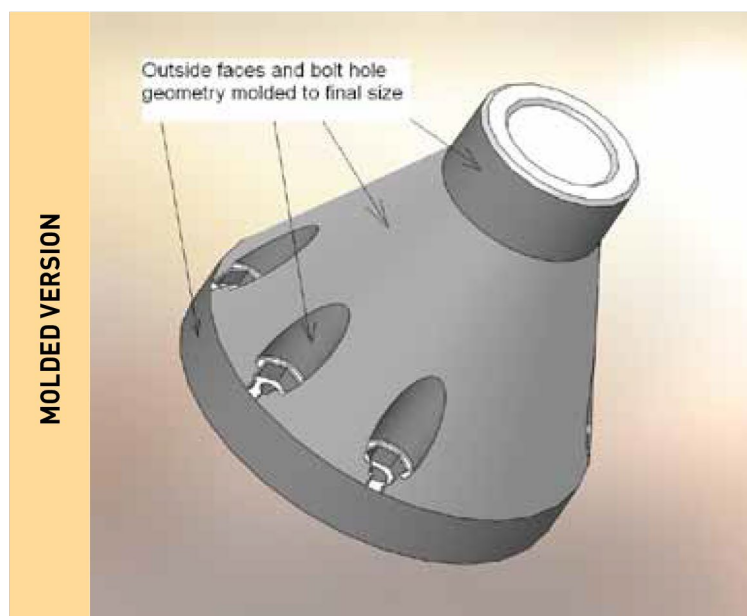
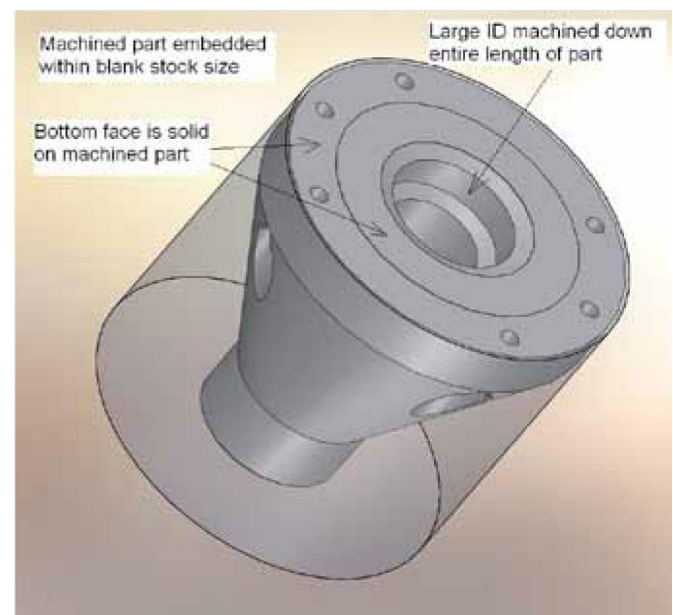
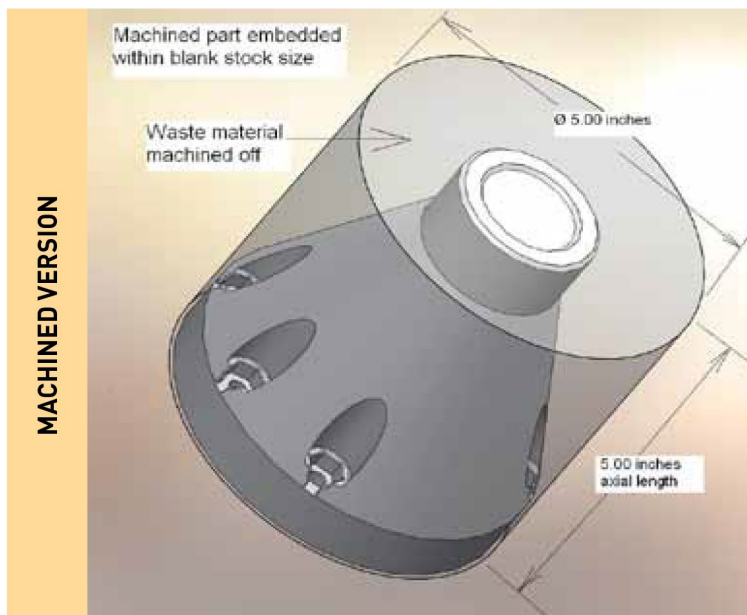

PREMIER®

Conductive Thermoplastics for EMI Shielding

Electrically Conductive EMI Shielding Thermoplastics

PREMIER® is the world's first and most versatile commercially available conductive thermoplastic for real world EMI shielding solutions. It is a blend of PC/ABS thermoplastic polymer alloys and conductive fillers engineered for stable electrical, mechanical, and physical performance. The conductive filler technology utilizes nickel plated carbon (Ni-C) fibers as the base filler. In the case of higher shielding versions, Nickel-Graphite (Ni-C) powder is blended with the fiber base to deliver enhanced performance.

Combined with standard injection molding processes, PREMIER technology delivers evenly dispersed filler throughout a part's geometry.

PREMIER parts have no resin rich areas prone to EMI leaks, and no brittle, resin poor areas that can break under mechanical stress. PREMIER provides world class shielding effectiveness, requires no machining, plating, painting, vacuum coating, or other added processing steps. The elimination of secondary operations can reduce costs by up to 50% compared to die castings, bent formed metal, machined extrusions and plated plastic parts.

PREMIER® EMI shielding performance is based upon proprietary filler technology which optimizes materials, dispersion and morphology.

The filler matrix within PREMIER starts with a nickel plated carbon (Ni-C) fiber. Electrolytic plating with nickel establishes excellent adhesion to the flexible carbon core, preventing stripping off of the nickel during the injection molding process. Enhanced

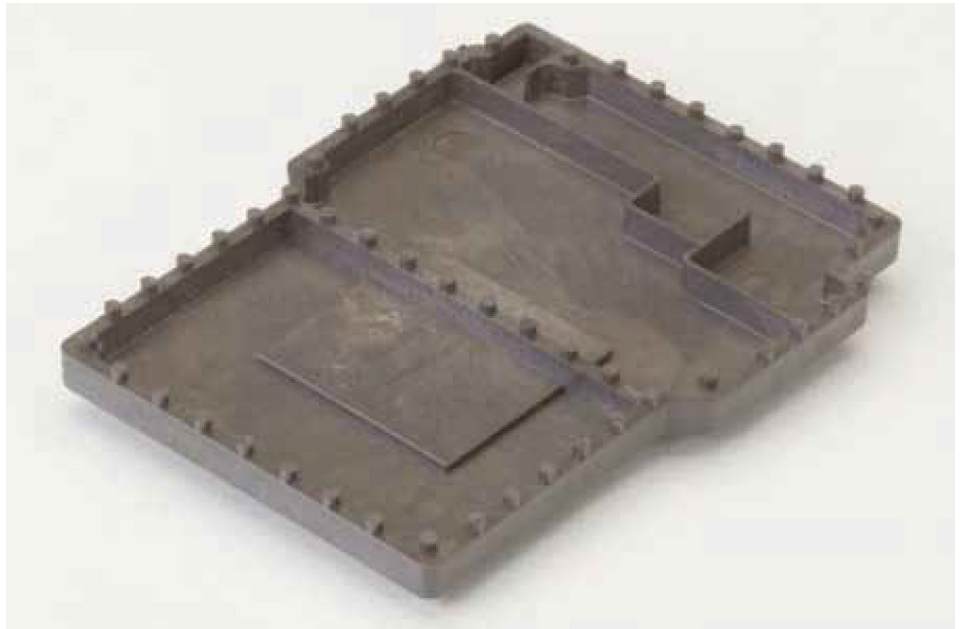

shielding performance and part fill is achieved by the addition of nickel plated graphite powder. By optimizing particle shape, size distribution and particle-to-fiber ratio, up to 85 dB of shielding effectiveness is obtained.

The powder is integrated into the fiber matrix securing more points of electrical contact both on the part surface and inter-fiber. PREMIER's uniquely engineered filler system delivers 6 sigma molding performance at various cost-performance break points. Unlike stainless steel fiber fillers, the carbon core will bend and flow around and into cavity details without breaking or clogging. The inherent material properties of both nickel and carbon make PREMIER a highly lossy (dissipates energy) material that is paramagnetic.

To ensure even dispersion, the Ni-C fibers are treated with a unique, proprietary dispersion technology. The dispersion agent, when combined with the low shear mechanical action experienced in the injection molding process, delivers a randomly oriented, evenly dispersed and interlocked fiber matrix within the polymer. Only Chomerics has a dispersion agent that effectively promotes an even matrix

throughout complex part geometry. Only PREMIER eliminates the gate clogging typically found with EMI shielding plastics.

When dispersed, the engineered fiber matrix provides optimum filler morphology for performance. The foundation of PREMIER's EMI shielding performance is the high aspect ratio Ni-C fiber. The long pathways of uninterrupted electrical conductivity provide low bulk conductivity. A minimum level of fiber is needed to provide effective EMI shielding and all grades of PREMIER have this level. To increase performance, particulate nickel graphite powder is added to the base fiber matrix to create higher shielding grades. The inclusion of powder to augment the fiber matrix is indicated by "HF" in the material grade designation.

PREMIER is a single component pellet system. The polymer is cross head extruded on top of the dispersion agent treated Ni-C fiber tow. The "HF" grade has nickel graphite powder that is compounded into the polymer. The polymer-filler system is chopped into pellets ready for injection molding. The pellet length optimizes the conductive fiber aspect ratio to maximize shielding.

The single component system eliminates mixing or weighing at the press, fiber nesting and clogged extruder throats. PREMIER parts provide shielding effectiveness greater than 85 dB to meet global commercial EMC requirements. PREMIER provides the electrical conductivity, EMI absorption, and mechanical durability to replace aluminum and plastic housings that have been metalized or conductively coated. The shielding effectiveness of

PREMIER is far greater than that of carbon-filled ESD (electrostatic discharge) plastics.

An application's mechanical design is critical to optimizing the shielding performance of any material. An effective EMI shielding scheme features a conductive shielding medium, with

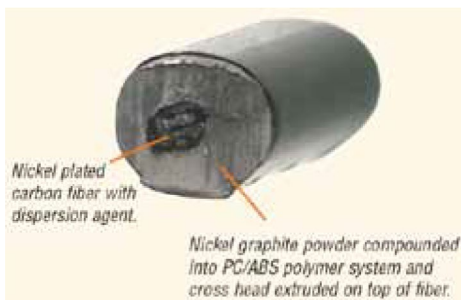

360 degrees peripheral ground and termination of the shield at mating flanges. For applications that do not use an EMI shielding gasket at the seams, or with large openings, PREMIER™ will perform comparably to metal based designs. The seam or opening will provide less shielding than the housing material, making the seam or opening the determining component of the housing's overall shielding performance. Generally, a non-gasketed seam with good incidental contact will deliver 60 to 70 dB (800 MHz to 12 GHz) shielding effectiveness in both PREMIER and aluminum. Typically, surface plated plastic housings will have 3 to 5 dB less shielding effectiveness than PREMIER. Copper-filled coatings will be 5 to 10 dB less. To optimize performance, a torturous path joint with a maximized surface area is suggested for seams instead of a simple butt joint. Five to 15 dB of shielding performance can be added to a typical PREMIER housing using a fabric-over-foam gasket, such as

Chomerics' SOFT-SHIELD® 3500, 3700 or 4800 Series, a form-in-place conductive elastomer gasket, such as Chomerics CHO-FORM® family of materials or a hollow/spliced conductive extrusion captured in a groove.

PEI-140 - High Temperature Conductive Plastic

PREMIER® PEI-140 is a custom blend of polyetherimide plus engineered filler for stable electrical, mechanical and physical performance at high continuous temperature exposures. It is filled with the production proven PREMIER proprietary filler system that is formulated for consistent shielding over a wide range of frequencies.

KEY CHARACTERISTICS

High Temperature Performance - (340°F/170°C)

Smoke Density - Meets guidelines for optical smoke density tests at MAX 110 D's requirement to pass is 200 D's or less.

Features & Benefits

Shielding

- High performance shielding up to 85 dB
- Low through resistance down to 30 m Ω
- Highly conductive
- High permeability (6.5) increases shielding effectiveness

Mechanical / Physical

- High tensile strength and modulus
- High flexural strength and modulus

- Low density provides weight reduction up to 75%
- Flammability rating: UL 94 V-0

Environmental

- Recyclable – conforms to WEEE EoVL TCO
- Compliance – RoHS, Halogen-free, EPA
- Up to 105°C Relative Temperature Index (RTI)
- Corrosion-free for long field life

Economics

- Lower total cost of ownership through elimination of secondary operations
- Six sigma processing
- Waste elimination
- Global supply available for rapid delivery

Table 2: Typical Properties – PREMIER® EMI Shielding Plastics

	Property	A220-HT	A230-HTHF	A240-HTHF	A220-FR	A230-FRHF	A240-FRHF	A220-ST	A230-ST	A240-ST	Test Method
Electrical	Filler Level	Low	Medium	High	Low	Medium	High	Low	Medium	High	
	Surface Resistance	4.5	0.6	0.25	4.5	0.6	0.25	4.5	0.5	0.2	
	Through Resistance	0.8	0.06	0.03	0.8	0.06	0.03	0.8	0.06	0.03	
Mechanical	Tensile Strength @ Break	67.6 (9,800)	71 (10,3000)	71.7 (10,400)	68.3 (9,900)	71 (10,300)	71.7 (10,400)	78.6 (11,400)	88.3 (12,800)	91 (13,200)	ASTM D638
	Tensile Elongation @ Break	1	1.2	0.5	1	1.2	0.5	1.65	1.02	0.5	ASTM D638
	Tensile Modulus	5.8 (0.84)	6.7 (0.97)	7.7 (1.17)	7.5 (1.00)	6.7 (0.97)	7.7 (1.17)	6.0 (0.88)	11.1 (1.62)	15.6 (2.27)	ASTM D638
	Flexural Strength	110 (15,900)	100 (15,000)	113 (16,400)	109 (15,800)	95 (13,700)	100 (15,000)	121 (17,600)	131 (19,000)	152 (22,000)	ASTM D790
	Flexural Modulus	5.2	6.3	8	5.2	6.3	8	5.4	8.1	11.9	ASTM D790
	RTI	85 (185)	85 (185)	85 (185)	70 (158)	70 (158)	70 (158)	105	105	105	UL746B
	Izod Impact (Unnotched)	197	176	192	197	176	192	298	233	234	ASTM D412
	Izod Impact (Notched)	74.7	53.3	64	58	53.3	64	77	93	120	ASTM D412
	Thermal Conductivity	0.56	0.59	0.7	0.56	0.59	0.7	0.56	0.59	0.7	ASTM D5470
Thermal	HDUL @ 18.2 bar (264 psi)	122	120	118	100	100	99	128	123	119	ASTM D648
	CLTE	0.26	0.3	0.18	0.5	0.3	0.18	0.29	0.15	0.13	ASTM D696
	Specific Gravity	1.2	1.39	1.4	1.2	1.39	1.4	1.2	1.31	1.4	ASTM D3763
Physical	Flammability	N/A	N/A	N/A	VO	VO	VO	N/A	N/A	N/A	UL 94

PARKER CHOMERICS LOCATIONS

To place an order please visit parker.com/chomerics or contact a Customer Service Representative at the following locations:

North America

Parker Chomerics Global Division Headquarters

77 Dragon Court
Woburn, MA
Phone +1 781-935-4850
Fax +781-933-4318
chomailbox@parker.com

Product Disclosure
(ROHS/REACH, Material
Declarations, SDS)
choproductdisclosure@parker.com

parker.com/chomerics

CHOB1013 February 2026

©2026 Parker Hannifin Corporation



WARNING:

The products described in this catalog can expose you to chemicals including Carbon black extracts, Naphthalene, N-methyl Pyrrolidone, Titanium Dioxide, Ethylene Oxide, Ethyl Benzene, Tetrafluoroethylene, Lead, Nickel Compounds, 1,3-Butadiene, DiChloromethane, Chloroprene, Di(2-ethylhexyl)phthalate(DEHP), Antimony Oxide, which are known to the State of California to cause cancer, and Methyl Chloride, Lead, 1,3 Butadiene, Toluene, EthyleneOxide, Di(2-ethylhexyl)phthalate(DEHP) which are known to the State of California to cause birth defects or other reproductive harm. For more information go to P65Warnings.ca.gov.

Europe

Parker Hannifin Ltd Chomerics Division Europe

Unit 6, Century Point
Halifax Road
High Wycombe
Bucks HP12 3SL
UK
Phone +44 1494 455400
Fax +44 14944 55466
chomerics_europe@parker.com

Asia Pacific

Parker Hannifin
Chomerics Shanghai
280 Yunqiao Road, Jin Qiao Export
Processing Zone, Shanghai 201206,
China
Phone +86 21 2899 5000
Fax +86 21 2899 5146
chomerics_ap@parker.com

Parker Hannifin
Chomerics Shenzhen
No.5 Bldg Jinrongda Technological Park
Gangtou Village, Bantian Longgang
District Shenzhen, 518122, China
Phone +86 755 8974 8558
Fax +86 755 8974 8560
chomerics_ap@parker.com

Asia Pacific

Parker Hannifin Chomerics Kula Lumpur

Lot 15, Jalan Gudang 16/9
Section 16, Shah Alam
Industrial Estate, 40200 Shah Alam
Selangor, Malaysia
Phone +603 5510 9188
Fax +603 5512 6988
chomerics_ap@parker.com

Penang, Malaysia
No.3, Puncak Perusahaan 1, 13600 Prai,
Penang, Malaysia
Phone +604 3983299
Fax +604 3983299
chomerics_ap@parker.com

Parker Hannifin India Private Limited
Chomerics Division
Plot No. 41/2, 8th AvenueDTA,
Anjur Village, Mahindra World City,
Chengalpattu, Tamilnadu - 603 004, India
Phone +91 44 67132333
Phone +91 44 67132045
chomerics_ap@parker.com

Manufacturing Facilities

- Woburn, MA, USA
- Hudson, NH, USA
- Fairport, NY, USA
- Monterrey, Mexico
- High Wycombe, UK
- Frépillon, France
- Sadska, Czech Republic
- Kuala Lumpur, Malaysia
- Chennai, India
- Shanghai, China
- Shenzhen, China