

## 2008 Dodge Wiring Information

Over the past several weeks it has come to our attention that for 2008 model year Dodge wiring connections for Chelsea P.T.O. function were shipped in two versions.

Working with Dodge engineering we have identified approximately 1,000 Dodge work trucks that have the incorrect wiring setup from what we have published in our owner's manual for wiring the 270 Series for model year 2008.

- The affected trucks are 2008 model year with 6.7L Diesel and the Aisin automatic transmission.
- The approximately 1,000 trucks that have a different wiring requirement we are calling them "Generation 1 (**Gen #1**)" wiring. For all others with the 6.7L w/Automatic "**Gen #2**".
- To identify if your truck has the following wiring setup, locate the wiring bundle located in the engine compartment near the master cylinder. If you have two "Unterminated" wires that are Pink w/ Yellow stripe, follow the instructions below and on the page titled "**Gen # 1 Upfitter Connector**"
  - Two wires that connect to the Dodge Upfitter Jumper through the 10 way connector under the instrument panel near the pass through grommet where left "Unterminated" in the wire bundle near the master cylinder.
  - These two wires both are Pink w/ Yellow stripe and are marked K425 and V937 on the chart for Gen#1 wiring (Dodge Unterminated bundle near Master Cylinder) and connect to the Engine Controller (EC).
  - Connect the two Pink w/ Yellow stripe wires together as noted in the wiring chart for Gen#1.
  - Connect Chelsea wire marked #2 (Violet #1) on the wiring chart (Violet #1) to Dodge Unterminated wire marked V937 (Violet w/ Brown stripe) on the chart and is located near the master cylinder. This now completes the circuit to the engine controller.
  - Connect the other Chelsea wires as indicated on the wiring chart for "Gen #1."

Also included with this bulletin are charts for the normal wiring of the 6.7L w/Automatic (**Gen #2**) and updated wiring information for the 6.7L w/ Manual.

Please make sure that this information is provided to customers that are installing Chelsea P.T.O. on 2008 Dodge trucks.

If you have questions about this bulletin or other technical questions, contact us at:

US: Chelsea Technical Services at 662-895-1052

Canada: Parker Hannifin Canada, Motion & Controls Division 905-693-3020



Walt Harris  
Product Sales Manager  
Chelsea Products

Gen #1 Upfitter Connector

Wiring Chart - Model Year 2008 Dodge Chassis Cab, 6.7L w/ Aisin Transmission

Chelsea Wire	Connected to Dodge Wire	Location
1 Orange	F923 Pink w/ Yellow Stripe	Upfitter Jumper Connector
2 Violet 1	V937 Violet w/ Brown Stripe	Unterminated Wires Near Master Cylinder
3 Violet 2	G425 Violet w/ Yellow Stripe	Upfitter Jumper Connector
4 Pink	F922 Pink w/ Red Stripe	Upfitter Jumper Connector
5 Orange	K427 Orange w/ Lt. Green Stripe	Unterminated Wires Near Master Cylinder
6 Pink	F922C Pink w/ Red Stripe	Unterminated Wires Near Master Cylinder
7 Black	Z914 Black	Unterminated Wires Near Master Cylinder
8 Violet	G425 Violet w/ Yellow Stripe	Unterminated Wires Near Master Cylinder
<b>Chelsea Wire</b>	<b>Connected to</b>	<b>Location</b>
9 Black w/ ring Terminal	Pressure Switch	PTO
10 Violet w/ ring Terminal	Pressure Switch	PTO
11 Black w/ Butt Connector	PTO Solenoid - Black Wire	Remotely Mounted On Vehicle
12 Red w/ Butt Connector	PTO Solenoid - Red Wire	Remotely Mounted On Vehicle

NOTE: Wire Numbers on the Chelsea Wiring Chart are for reference only.

NOTE: Upfitter Connector is shipped loose with vehicle and is stored behind seat.

NOTE: Locate the two Pink w/ Yellow stripe Dodge wires in the unterminated bundle near the master cylinder and connect them together

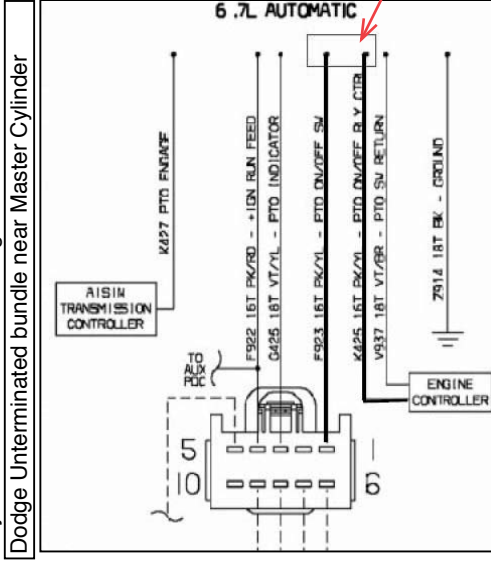
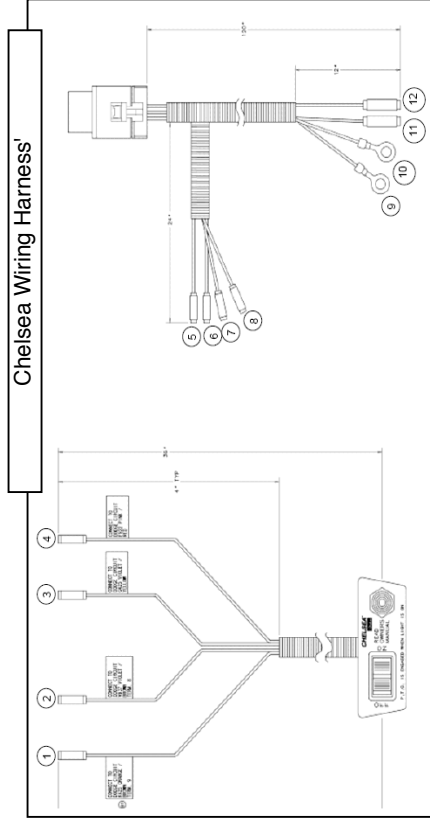

Dodge Unterminated bundle near Master Cylinder

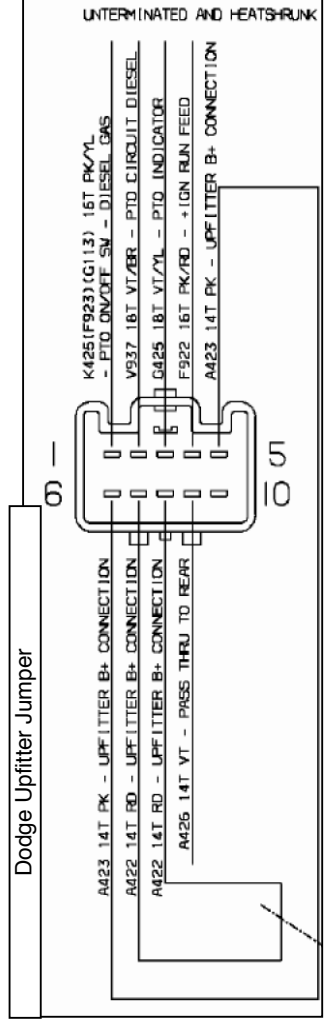

Connect Wires

Gen #2 Uppfitter Connector

Wiring Chart - Model Year 2008 Dodge Chassis Cab, 6.7L w/ Aisin Transmission

Chelsea Wire	Connected to Dodge Wire	Location
1 Orange	K425 Pink w/ Yellow Stripe	Uppfitter Jumper Connector
2 Violet 1	V937 Violet w/ Brown Stripe	Uppfitter Jumper Connector
3 Violet 2	G425 Violet w/ Yellow Stripe	Uppfitter Jumper Connector
4 Pink	F922 Pink w/ Red Stripe	Uppfitter Jumper Connector
5 Orange	K427 Orange w/ Lt. Green Stripe	Unterminated Wires Near Master Cylinder
6 Pink	F922C Pink w/ Red Stripe	Unterminated Wires Near Master Cylinder
7 Black	Z914 Black	Unterminated Wires Near Master Cylinder
8 Violet	G425 Violet w/ Yellow Stripe	Unterminated Wires Near Master Cylinder
Chelsea Wire	Connected to	Location
9 Black w/ ring Terminal	Pressure Switch	PTO
10 Violet w/ ring Terminal	Pressure Switch	PTO
11 Black w/ Butt Connector	PTO Solenoid - Black Wire	Remotely Mounted On Vehicle
12 Red w/ Butt Connector	PTO Solenoid - Red Wire	Remotely Mounted On Vehicle

NOTE: Wire Numbers on the Chelsea Wiring Chart are for reference only.

NOTE: Uppfitter Connector is shipped loose with vehicle and is stored behind seat.

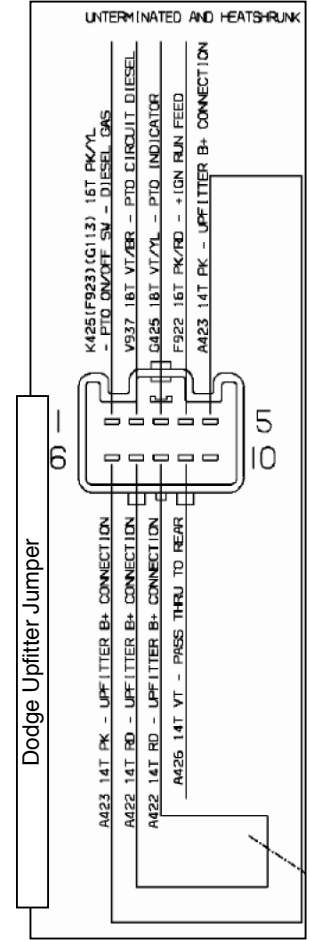
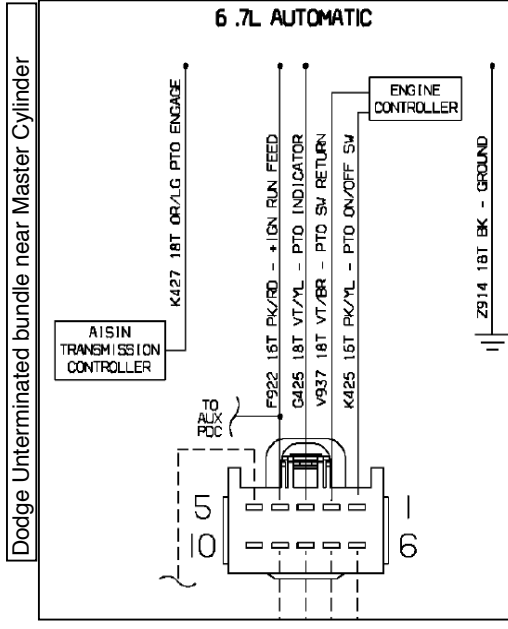
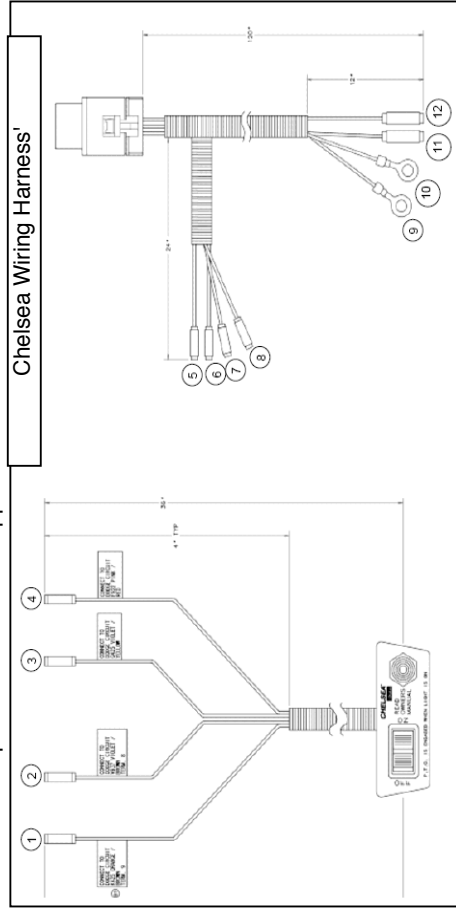

6.7L w/ Manual

Wiring Chart - Model Year 2008 Dodge Chassis Cab, 6.7L w/ G56 Transmission

Chelsea Wire	Connected to Dodge Wire	Location
1 Violet	G425 Violet w/ Yellow Stripe	Upfitter Jumper Connector
2 Pink	F922 Pink w/ Red Stripe	Upfitter Jumper Connector
3 Violet	G425 Violet/ Yellow Strip	Unterminated Wires Near Master Cylinder
4 Pink	K425 Pink w/ Yellow Stripe	Unterminated Wires Near Master Cylinder
5 Violet	V937 Violet/Brown Stripe	Unterminated Wires Near Master Cylinder
6 Pink	F922 Pink/ Red Stripe	Unterminated Wires Near Master Cylinder
Chelsea Wire	Connected to	Location
7 Black w/ Booted Connector	Pressure Switch	PTO

NOTE: Wire Numbers on the Chelsea Wiring Chart are for reference only.

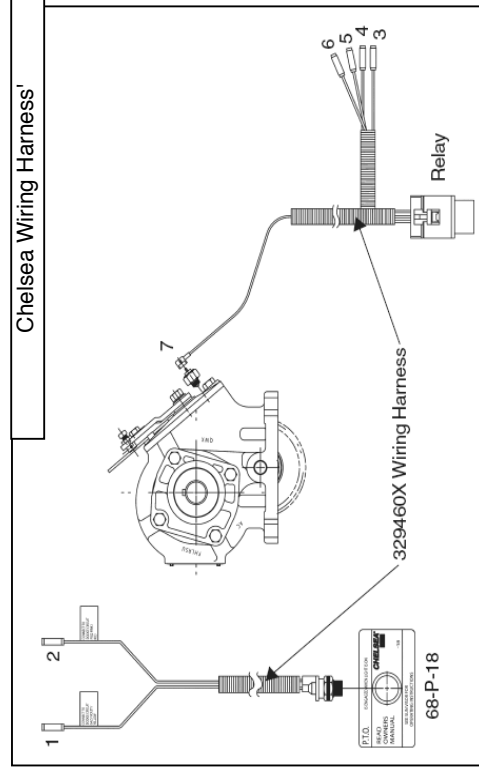

Dodge Unterminated bundle near Master Cylinder

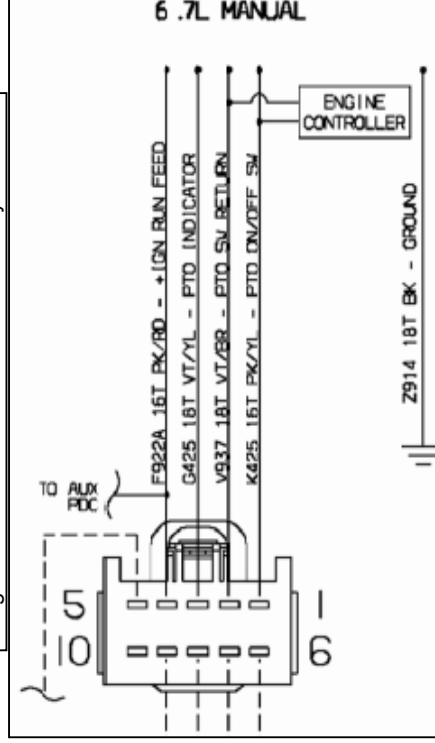

Dodge Upfitter Jumper

