

Fusor[®] 802HD PLUS/804HD PLUS/ 805HD PLUS/806HD PLUS High Definition Sprayable Sealer

Technical Data Sheet

Fusor[®] High Definition (HD) PLUS sprayable sealers are one-component seam sealers used for duplicating the look and function of OEM beaded sealers, wheelhouse coatings, and sound deadening material. Utilizing Silane Terminated Polymer (STP) technology, Fusor HD PLUS sealers can be applied on bare and properly primed metals, SMC, and Fiberglass[®].

Fusor HD PLUS sealers are available in the following colors:

- White – Fusor 802HD PLUS High Definition Sprayable Sealer
- Gray – Fusor 804HD PLUS High Definition Sprayable Sealer
- Black – Fusor 805HD PLUS High Definition Sprayable Sealer
- Beige – Fusor 806HD PLUS High Definition Sprayable Sealer

Features and Benefits:

High Definition Appearance – easily duplicates factory-applied textured seams; provides extremely flexible, non-yellowing seal with no shrinkage, cracking or sagging.

High Performance – provides excellent adhesion to bare or primed surfaces; firm texture will not imprint.

Versatile – adheres to bare metal or primed surfaces; can be used for duplicating OEM spray-applied seam sealers and surface coatings; can be spot welded while still wet.

Environmentally Resistant – provides excellent UV and moisture resistance and corrosion protection.

Easy to Finish – can be tooled and wiped clean; offers immediate paint time; tools easily without solvents.

Environmentally Recommended – contains low VOCs and no solvents or isocyanates.

Extended Shelf Life – offers longer shelf life, reducing inventory costs.

Application:

Prepare – If sealing bare metal, scuff the surface with a red scratch pad and blow off area with dry, filtered compressed air.

If priming bare metal before sealer application, prime the surface using a two-component catalyzed primer according to paint manufacturer's instructions. For optimal adhesion, scuff the primed surface with a red scratch pad and blow off area with dry, filtered compressed air.

Typical Properties*

Appearance	White, Gray, Black or Beige Paste
Base Chemistry	Silane Terminated Polymer (STP)
Skin Time**	25 minutes @ 70°F (21°C), 50% RH
Paint Time	Immediately; up to 30 days without a scuff (Test with paint system)

*Data is typical and not to be used for specification purposes.

**Varies with temperature/humidity.

Apply – Cut cartridge tip at top of the threads, and puncture inner foil seal. Using Fusor 312 sprayable seam sealer applicator, unscrew and remove the tube; insert cartridge; rescrew tube for a tight seal (see Figure 1).

Note: Be sure the o-ring is located in the head of the applicator, and is not attached to empty cartridge when loading a new cartridge.

Adjust the air pressure and spray pattern of applicator to achieve the desired texture and pattern. The texture and pattern will vary with applicator distance from the part. A spray out test panel of Fusor HD PLUS sealer is recommended.

Note: Various applications, cleaners/solvents and coatings may not be compatible with this product and should be tested by the user before proceeding with intended repair procedure.

Finish – To tool or spread sealer after application, use water and an acid brush or small painters chip brush to draw down and match OEM appearance. Remove any masking tape immediately after tooling or brushing.

If needed, paint per manufacturer’s recommendations immediately or within 30 days.

For more application information, refer to www.parker.com/APS for standard operating procedures or application training videos.

Technical Tips:

- Always scuff and solvent clean the surface using a non-residual solvent (e.g., reducer, lacquer thinner, acetone, etc.), ensuring that all solvent has evaporated, before applying Fusor HD PLUS sealer.
- “Properly primed” metal includes factory e-coat and paint or field-applied, fully cured, two-component catalyzed epoxy or urethane primers which have been abraded and cleaned.

- Applying Fusor HD PLUS sealers over one-component coatings or primers may lead to application or product failure even where product instructions state material is “cured”.
- Do not apply solvents to the Fusor HD PLUS sealer surface; always finish with recommended components of a refinish paint system including a two-component catalyzed primer before the base coat.
- Do not use Fusor HD PLUS sealers as a rocker panel or stone guard coating.
- When spray applying over bare substrate, it is important to ensure 100% contact with the base substrate. Simply spray apply a thin layer of material and then tool smooth with a spreader, rag or brush ensuring 100% coverage. Apply the final textured coating over this prepared material. Spray-applied texture may be “porous” and this will guarantee full protection of the substrate.

Shelf Life/Storage:

Shelf life is 15 months from date of manufacture when stored below 75°F (24°C) in original, unopened container. Store product in a cool, dry location.

Cautionary Information:

Before using this or any Parker Lord product, refer to the Safety Data Sheet (SDS) and label for safe use and handling instructions.

For industrial/commercial use only. Must be applied by trained personnel only. Not to be used in household applications. Not for consumer use.

Durability Performance*

Elongation	500%
Corrosion Control	500 hours, ASTM B117 Salt Spray

* Data is typical and not to be used for specification purposes.

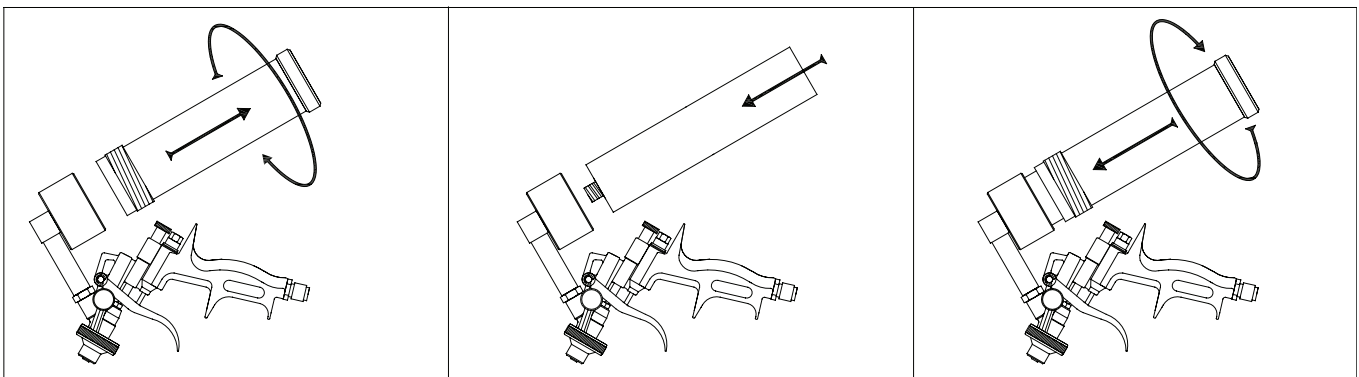

Figure 1. Insert Cartridge in Applicator

Fusor® Repair Products Lifetime Guarantee*

LORD Assembly & Protection Solutions Division of Parker-Hannifin Corporation (“Parker Lord”) guarantees to the user that Fusor® Repair Products (adhesives, primers, seam sealers and foams only), when used in strict accordance with Parker Lord application and use instructions, will provide a durable repair for the life of the vehicle per the product’s technical data sheet. The user is solely responsible for determining the Fusor product and application method for the repair. Application and product guidance can be found on Fusor.com.

THIS EXPRESS WARRANTY IS MADE IN LIEU OF AND EXCLUDES ANY AND ALL OTHER WARRANTIES, EXPRESS OR IMPLIED, BY OPERATION OF LAW OR OTHERWISE, INCLUDING THE IMPLIED WARRANTIES OF MERCHANTABILITY AND FITNESS FOR A PARTICULAR PURPOSE.

Parker Lord shall not be liable under any circumstance for any liability, loss, damage or expense directly or indirectly arising from the application and use of Fusor Products sold hereunder or from any other cause. Parker Lord shall not be liable under any circumstances for consequential, indirect or special damages. **PARKER LORD’S LIABILITY FOR BREACH OF WARRANTY HEREUNDER IS IN ALL INSTANCES LIMITED SOLELY AND EXCLUSIVELY TO THE REASONABLE COSTS OF REPAIR AND/OR REPLACEMENT OF THE BONDED COMPONENTS OF THE VEHICLE.**

This guarantee shall only apply to the above referenced Fusor products sold by Parker Lord on or after January 1, 2001.

Fusor Metal Bonding Adhesives shall only be used for the adhesive-only bonding (no welds or rivets) of metal to metal assemblies (steel or aluminum) in full or partial panel replacements of door skins, roof skins, quarter panels, rear body panels and other outer body sheet metal where approved by the vehicle manufacturer.

Fusor products shall not be used for adhesive-only bonding of any structural component unless specifically recommended by the vehicle manufacturer. Structural panels must be replaced in strict compliance with vehicle manufacturer guidelines. If in doubt as to what is a structural component or the proper installation method, contact the vehicle manufacturer. Further, any Fusor products used in marine composite repair, such as with personal water craft and the like, shall be limited to repairs above the water line.

If you have any questions or need to receive proper use instructions, contact the Parker Lord Customer Support Center at +1 800 234 Fusor (3876) or visit Fusor.com.

To comply with the requirements of the Fusor Repair Products Lifetime Guarantee, attach a copy of this completed page to the repair record, and retain with your files:

Vehicle Make/Model: _____

Vehicle Identification Number: _____

Fusor Product(s) Used for Repair: _____

Lot Number(s) on Cartridge(s) Used for Repair: _____

**This guarantee is void if product is used after the date printed on the cartridge label. Parker Lord Terms and Conditions of Sale shall apply to all sales of Fusor products.*



Continuing Automotive Service Education
(CERTIFIED TRAINING PROVIDER)

Values stated in this document represent typical values as not all tests are run on each lot of material produced. For formalized product specifications for specific product end uses, contact the Customer Support Center.

Information provided herein is based upon tests believed to be reliable. In as much as Parker Lord has no control over the manner in which others may use this information, it does not guarantee the results to be obtained. In addition, Parker Lord does not guarantee the performance of the product or the results obtained from the use of the product or this information where the product has been repackaged by any third party, including but not limited to any product end-user. Nor does the company make any express or implied warranty of merchantability or fitness for a particular purpose concerning the effects or results of such use.

WARNING — USER RESPONSIBILITY. FAILURE OR IMPROPER SELECTION OR IMPROPER USE OF THE PRODUCTS DESCRIBED HEREIN OR RELATED ITEMS CAN CAUSE DEATH, PERSONAL INJURY AND PROPERTY DAMAGE.

This document and other information from Parker-Hannifin Corporation, its subsidiaries and authorized distributors provide product or system options for further investigation by users having technical expertise.

The user, through its own analysis and testing, is solely responsible for making the final selection of the system and components and assuring that all performance, endurance, maintenance, safety and warning requirements of the application are met. The user must analyze all aspects of the application, follow applicable industry standards, and follow the information concerning the product in the current product catalog and in any other materials provided from Parker or its subsidiaries or authorized distributors.

To the extent that Parker or its subsidiaries or authorized distributors provide component or system options based upon data or specifications provided by the user, the user is responsible for determining that such data and specifications are suitable and sufficient for all applications and reasonably foreseeable uses of the components or systems.

©2023 Parker Hannifin - All Rights Reserved

Information and specifications subject to change without notice and without liability therefor. Trademarks used herein are the property of their respective owners.

OD DS6231 08/23 Rev.1



Parker Lord
Engineered Materials Group

111 LORD Drive
Cary, NC 27511-7923
USA

phone +1 877 275 5673

www.Parker.com/APS