

# FUSOR® 127EZ PLASTIC BONDING ADHESIVE (SLOW)

## Technical Data Sheet

Fusor® 127EZ adhesive is a two-component, urethane-based adhesive used for bonding plastic body panels, spoilers and ground effects.

### Features and Benefits

**High Performance:** provides high strength for structural applications.

**Versatile:** bonds SMC, fiberglass, carbon fiber, plastics, and primed metal.

**Convenient:** provides enough work time for bonding large primed metal or plastic parts.

**Non-Sag:** remains in position when applied on vertical or overhead surfaces; easy to apply.

### Application

**Prepare:** If bonding metal, prime all bare metal using a two-component epoxy primer. Allow the primer to completely dry, then scuff-sand the primed areas with 180- or 220-grit sandpaper.

If bonding plastic, clean the area to be bonded with Fusor 703 adhesion prep/cleaner. Scuff-sand the bond areas with 80-grit sandpaper. Wipe with a clean dry rag.

**Apply:** Load the cartridge into the applicator and remove the end cap. Level the plungers by expelling a small amount of adhesive to ensure that material is coming out of both sides of the cartridge. Attach mixing tip and dispense a mixer length of adhesive to verify the material is evenly mixed.

Apply a bead large enough to fill any gaps between the panel and the inner reinforcement (see Figure 1). The recommended bead size is 1/2 inch (12.7 mm). Clamp panels with enough pressure to hold the panel in place while allowing a small amount of adhesive to squeeze out.

**Note:** Various applications, cleaners/solvents and coatings may not be compatible with this product and should be tested by the user before proceeding with intended repair procedure.

**Finish:** Allow adhesive to cure for 5 hours at room temperature, 70°F (21°C), before unclamping. Prime and paint per manufacturer's recommendations.

**Note:** Fusor 127EZ adhesive is not to be used as a seam sealer or filler. Avoid the application of polyester body fillers directly on top of the adhesive or swelling and/or blistering may occur.

For more application information, refer to [www.Parker.com/APS](http://www.Parker.com/APS) for standard operating procedures or application training videos.

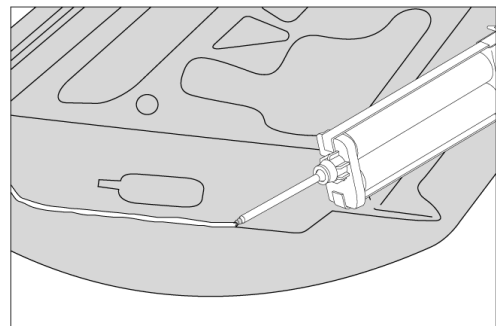

Figure 1. Apply Adhesive

### Typical Properties\*

Appearance	Off-white Paste
Base Chemistry	Urethane
Work Time	50 minutes @ 70°F (21°C)
Clamp Time	5 hours @ 70°F (21°C); 30 minutes @ 140°F (60°C)
Paint Time	4 hours @ 70°F (21°C); 30 minutes @ 140°F (60°C)
Cure Time	24 hours @ 70°F (21°C); 60 minutes @ 140°F (60°C)

\*Data is typical and not to be used for specification purposes.

## Shelf Life/Storage

Shelf life is 24 months from date of manufacture when stored at 75°F (24°C) in original, unopened container.

## Cautionary Information

Before using this or any Parker Lord product, refer to the Safety Data Sheet (SDS) and label for safe use and handling instructions.

*For industrial/commercial use only.* Must be applied by trained personnel only. Not to be used in household applications. Not for consumer use.

## Fusor® Repair Products Lifetime Guarantee\*

LORD Assembly & Protection Solutions Division of Parker-Hannifin Corporation ("Parker Lord") guarantees to the user that Fusor® Repair Products (adhesives, primers, seam sealers and foams only), when used in strict accordance with Parker Lord application and use instructions, will provide a durable repair for the life of the vehicle per the product's technical data sheet. The user is solely responsible for determining the Fusor product and application method for the repair. Application and product guidance can be found on Fusor.com.

**THIS EXPRESS WARRANTY IS MADE IN LIEU OF AND EXCLUDES ANY AND ALL OTHER WARRANTIES, EXPRESS OR IMPLIED, BY OPERATION OF LAW OR OTHERWISE, INCLUDING THE IMPLIED WARRANTIES OF MERCHANTABILITY AND FITNESS FOR A PARTICULAR PURPOSE.**

Parker Lord shall not be liable under any circumstance for any liability, loss, damage or expense directly or indirectly arising from the application and use of Fusor Products sold hereunder or from any other cause. Parker Lord shall not be liable under any circumstances for consequential, indirect or special damages. **PARKER LORD'S LIABILITY FOR BREACH OF WARRANTY HEREUNDER IS IN ALL INSTANCES LIMITED SOLELY AND EXCLUSIVELY TO THE REASONABLE COSTS OF REPAIR AND/OR REPLACEMENT OF THE BONDED COMPONENTS OF THE VEHICLE.**

This guarantee shall only apply to the above referenced Fusor products sold by Parker Lord on or after January 1, 2001.

Fusor Metal Bonding Adhesives shall only be used for the adhesive-only bonding (no welds or rivets) of metal to metal assemblies (steel or aluminum) in full or partial panel replacements of door skins, roof skins, quarter panels, rear body panels and other outer body sheet metal where approved by the vehicle manufacturer.

Fusor products shall not be used for adhesive-only bonding of any structural component unless specifically recommended by the vehicle manufacturer. Structural panels must be replaced in strict compliance with vehicle manufacturer guidelines. If in doubt as to what is a structural component or the proper installation method, contact the vehicle manufacturer. Further, any Fusor products used in marine composite repair, such as with personal water craft and the like, shall be limited to repairs above the water line.

Parker Lord  
Engineered Materials Group  
111 LORD Drive  
Cary, NC 27511-7923  
USA  
phone +1 877 275-5673  
www.parker.com/APS

DS6227 OD 12/24 Rev.1

Information and specifications subject to change without notice and without liability therefor. Trademarks used herein are the property of their respective owners.

© 2024 Parker Hannifin Corporation



## Durability Performance\*

Lap Shear Strength	Substrate failure occurred before bond failure on ABS, PVC, SMC, acrylic, XENOY® or polycarbonate
Torsional Impact Resistance	Substrate failure occurred before bond failure or bond assembly exceeded test protocol on ABS, PVC, SMC, acrylic, XENOY or polycarbonate

\*Data is typical and not to be used for specification purposes.

If you have any questions or need to receive proper use instructions, contact the Parker Lord Customer Support Center at +1 800 234 Fusor (3876) or visit Fusor.com.

**To comply with the requirements of the Fusor Repair Products Lifetime Guarantee, attach a copy of this completed page to the repair record, and retain with your files:**

Vehicle Make/Model: \_\_\_\_\_

Vehicle Identification Number: \_\_\_\_\_

Fusor Product(s) Used for Repair: \_\_\_\_\_

Lot Number(s) on Cartridge(s) Used for Repair: \_\_\_\_\_

*\*This guarantee is void if product is used after the date printed on the cartridge label. Parker Lord Terms and Conditions of Sale shall apply to all sales of Fusor products.*



Continuing Automotive Service Education  
CERTIFIED TRAINING PROVIDER

Values stated in this document represent typical values as not all tests are run on each lot of material produced. For formalized product specifications for specific product end uses, contact the Customer Support Center.

Information provided herein is based upon tests believed to be reliable. In as much as Parker Lord has no control over the manner in which others may use this information, it does not guarantee the results to be obtained. In addition, Parker Lord does not guarantee the performance of the product or the results obtained from the use of the product or this information where the product has been repackaged by any third party, including but not limited to any product end-user. Nor does the company make any express or implied warranty of merchantability or fitness for a particular purpose concerning the effects or results of such use.

WARNING — USER RESPONSIBILITY: FAILURE OR IMPROPER SELECTION OR IMPROPER USE OF THE PRODUCTS DESCRIBED HEREIN OR RELATED ITEMS CAN CAUSE DEATH, PERSONAL INJURY AND PROPERTY DAMAGE.

This document and other information from Parker-Hannifin Corporation, its subsidiaries and authorized distributors provide product or system options for further investigation by users having technical expertise.

The user, through its own analysis and testing, is solely responsible for making the final selection of the system and components and assuring that all performance, endurance, maintenance, safety and warning requirements of the application are met. The user must analyze all aspects of the application, follow applicable industry standards, and follow the information concerning the product in the current product catalog and in any other materials provided from Parker or its subsidiaries or authorized distributors.

To the extent that Parker or its subsidiaries or authorized distributors provide component or system options based upon data or specifications provided by the user, the user is responsible for determining that such data and specifications are suitable and sufficient for all applications and reasonably foreseeable uses of the components or systems.