



Aerospace
Engineered Materials
Filtration
Fluid Connections
Hydraulics
Instrumentation



PECO Oil & Gas Filtration

General Products Catalog



ENGINEERING YOUR SUCCESS.

Parker Hannifin Corporation, global leader in motion and control technologies, delivers an unmatched breadth of engineered products and solutions. Our commitment to our customers is backed by the strength that comes from over 100 years of knowledge and experience.

About PECO

For over 80 years the PECO brand of products has led the way in oil & gas filtration solutions. Customers trust the PECO brand for quality and performance to handle complex contaminant management issues. Total cost of filtration is not just about how much a filter costs, but rather how much overall cost of maintenance it can reduce. Adding PECO filtration equipment to your process will diminish contaminant build-up in process equipment, protect critical equipment from damage, help minimize downtime, lower energy consumption, and keep products within spec.

The PECO breadth of products continues to evolve, with safety and innovation in mind, for an ever-changing industry landscape and an environmentally conscious world.



Your Contaminant Management Partner

In oil & gas applications, contaminants come in a wide variety of forms. Not only are we dealing with removal of solids, liquids and gases but also complex mixtures which create sludges, gels and foams. At Parker we believe that proper oil & gas filtration shouldn't be solved by just one type of equipment or cartridge style. That is why we have a variety of PECO filter vessels and cartridges to handle even the most difficult of contaminant removal challenges. We always believe "The Contaminant Dictates the Method" upon which filter products we select. With over eight PECO categories of filter vessels and a multitude of PECO depth or pleated cartridge options, we can ensure the right selection for our customers' application needs.

TABLE OF CONTENTS

About the PECO Brand.....	1
Filtration Technology Timeline.....	3-4
Filtration Equipment Selection Guide.....	5-6
Gas Filtration	
Horizontal Gas Coalescer (<i>PEACH Gemini PuraSep® 2</i>).....	7-8
Vertical Gas Coalescers (<i>Spartan PuraSep®</i>).....	9
Gas Filter-Separators.....	10
Gas Filter-Separators & Dry Gas Filters (<i>Titan PuraSep®</i>).....	11-12
In-Line Dry Gas Filters.....	13
Gas Separators & Scrubbers.....	14-15
Gas Cyclone Separators.....	16
Auto-Cleaning Metallic Filters.....	17
Engineered Filtration and Separation Skid Packages.....	18
Liquid Filtration	
Auto-Clean Water Filtration System (<i>BlastPure®</i>).....	19-20
High Flow Capacity Liquid Filters (<i>XtreamPure®</i>).....	21-22
Economy Liquid Filters (<i>Chemelean®</i>).....	23
Activated Carbon Adsorbers (<i>XtreamSorb®</i>).....	24
Liquid/Liquid Phase Coalescers (<i>XtreamPhase®</i>).....	25-26



PROVIDING FILTRATION & SEPARATION FOR THE OIL & GAS INDUSTRY

- Offshore Exploration & Production
- Water Disposal
- Gas Gathering
- Gas Processing
- Gas Transmission
- Gas Storage
- LNG Liquification
- Power Generation
- City Gates
- Vehicle CNG
- NGL Pipeline & Storage
- Fractionation
- Refining
- Petrochemical

PECO - FILTRATION TECHNOLOGY TIMELINE

1936



Bypass Lube Oil Sock Filter

1949

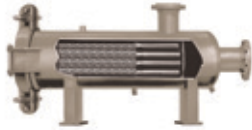

Dry Gas Filter

1953



Gas Filter-Separator

1955



Hook Vane

1965



Quick Opening Closure



Generation 2 performance level recipes for PEACH[®] Saturated Depth Coalescers



PEACH[®] GOLD Cartridges



ProComp VKO[®] Vertical Knock-Out Gas Coalescer



PECO SafeLock Closure[®]

2004

2003

2002

2001

2007



PEACH[®] Fusion



SafeLock 2 Closure



PlantGard[®] On-Line Monitoring



Generation 3 performance level recipes for PEACH[®] Saturated Depth Coalescers

2008



XtreamPure[®] High Flow Liquid Filtration



VKC Cyclonic Technology

2012

2013

2014

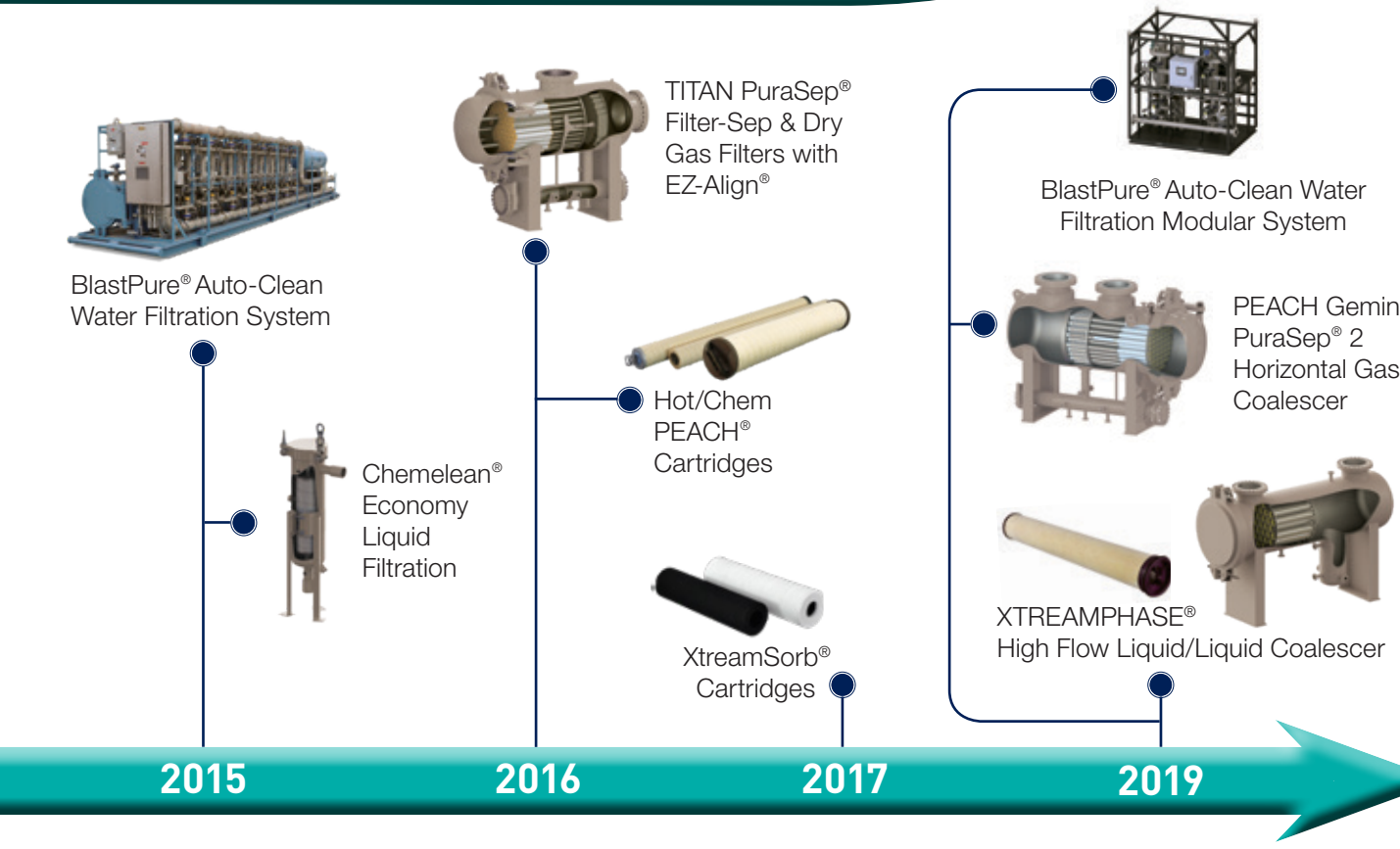
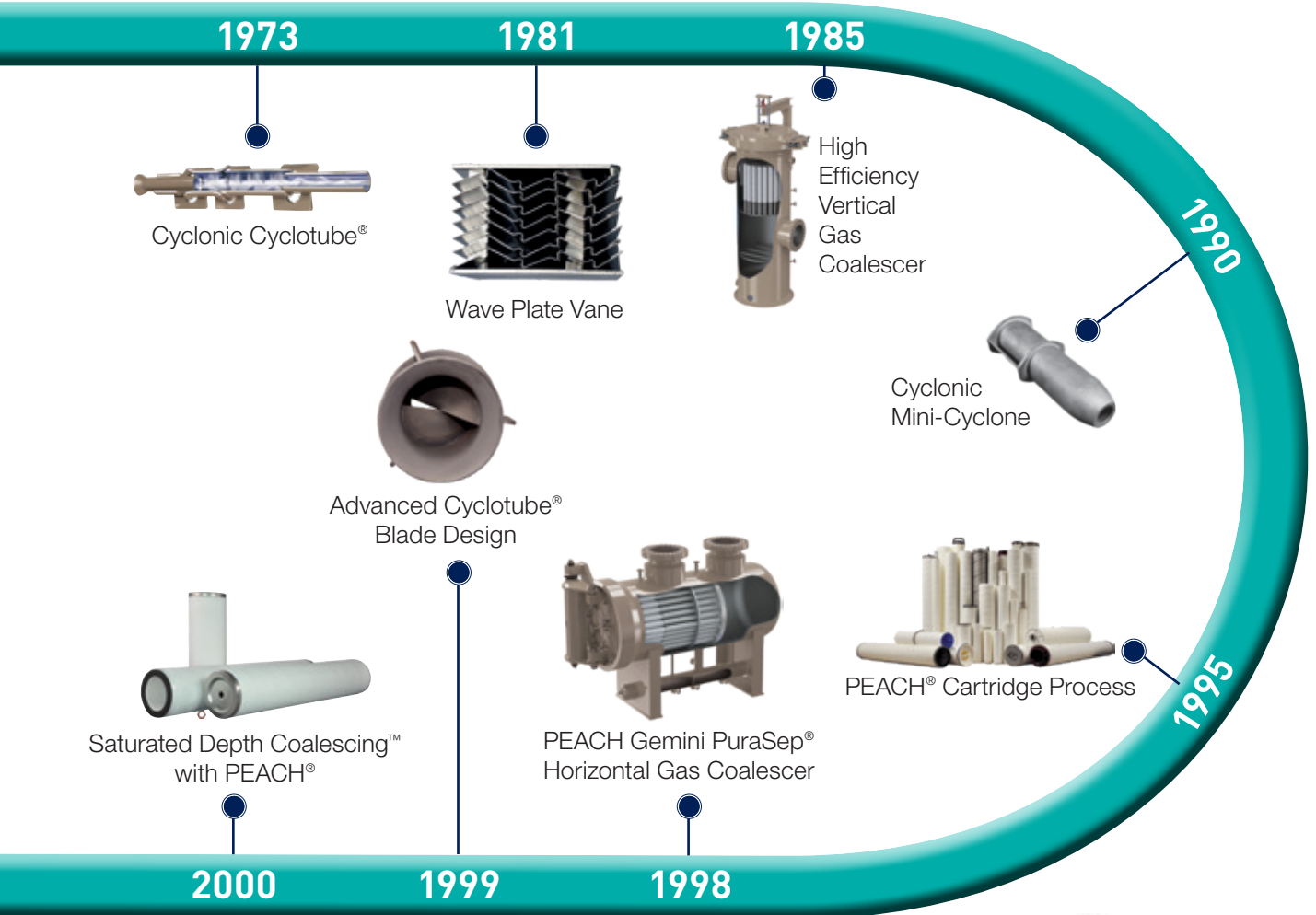

ALL YOUR FILTRATION

**Wet Gas
High Capacity
Filtration &
High Efficiency
Coalescing**
0.3 µm

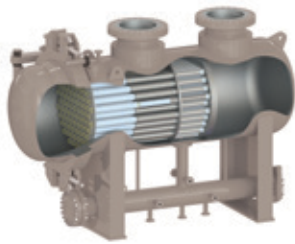

PEACH Gemini PuraSep® 2
Series GEM2

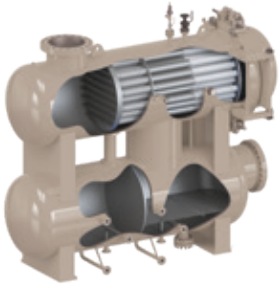

PEACH Gemini PuraSep® 2
Series GEM2-Slug

**Wet Gas Aerosol
Liquid High
Efficiency
Coalescing**
0.3 µm



Series 89



Spartan PuraSep®
Series 77V



Spartan PuraSep®
Series 77V-VKO

**Wet Gas
Filtration
& Separation
Filter-Sep**
1 µm



Series 85

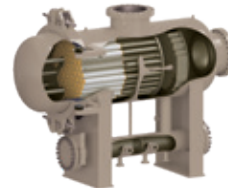

TITAN PuraSep®
Series 75HTL



TITAN PuraSep®
Series 75VTL



Boot-Sep™
Series GPFS

**Wet Gas Bulk
Liquid
Separation**
3–10 µm



Series 95V

Series 95SV

Series 95V-CT



Series 95SV-CT



Series 95H-VBANK



Series 95H-CT



Series 95H-WP

NEEDS IN ONE LOCATION

Dry Gas Filtration 1 µm



TITAN PuraSep®
Series 70HTL



TITAN PuraSep®
Series 70VTL



Series 30



Series 30F



Series 95V- MC

Liquid Filtration 1–100 µm



XtreamPure®
Series 55VX

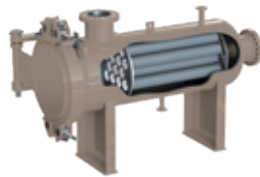

XtreamPure®
Series 55HX



Series 55



Chemelean®
Series 55C

Liquid Phase Coalescing



XtreamPhase®
Series 110HXP w/cartridges

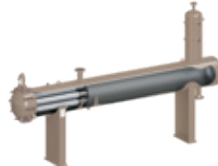

XtreamPhase®
Series 110HRXP w/cartridges



XtreamPhase®
Series 110V

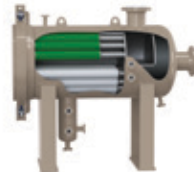

XtreamPhase®
Series 110H w/cartridges



XtreamPhase®
Series 110H w/wafer pack

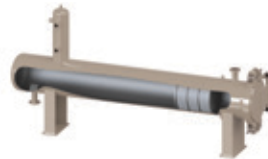

XtreamPhase®
Series 110HR w/wafer pack

Liquid Adsorption



Series 10



Series 10FB



XtreamSorb®
Series 14

PEACH Gemini PuraSep[®] 2

Horizontal Gas Coalescer

The **PEACH Gemini PuraSep 2** is an innovative product in gas coalescing technology which provides the solids loading capabilities of a filter-separator with the liquid removal efficiency of a vertical coalescer. This patented design provides ultra-clean gas with high efficiency removal of solid and liquid contaminants down to 0.3 microns. It can effectively handle higher inlet solid and liquid loads versus conventional vertical coalescing equipment and is designed to remove a wide range of liquid contaminants such as lubricating oils, low surface tension liquids and aerosol mists.

Two stages of coalescing and separation are contained in a single, easily replaceable PEACH Gemini cartridge. Eliminating the need for a conventional 2nd stage mist extraction device, such as a vane or Cyclotube[®], means no concerns of plugging or corrosion. The cartridge seats inside the vessel via a riser tube with the use of a chevron seal. The seal provides a separation of the cartridge so that gas entering the vessel will flow from outside-to-inside through the front of the cartridge (1st stage) where solids are removed and coalescing is begun. Once past the chevron seal, the gas will flow inside-to-outside through the back of the cartridge (2nd stage) providing a smooth transition of coalesced liquids from the 1st stage into the 2nd stage. Keeping in mind the importance today's customer places on minimizing operation and maintenance costs, simple, quick and trouble-free operation has been incorporated into the PEACH Gemini PuraSep 2 design.

Features

- Handled End Cap
- Improved Cartridge Drain Layer
- PEACH Sleeve
- Roll-out Seal System (ROSS)
- Liquid Drainage Device (LIB)
- Safe, User Friendly Design
- 0.3 Micron High Efficiency Coalescing
- Horizontal Configuration
- 100% Turndown
- Quick Opening Closures

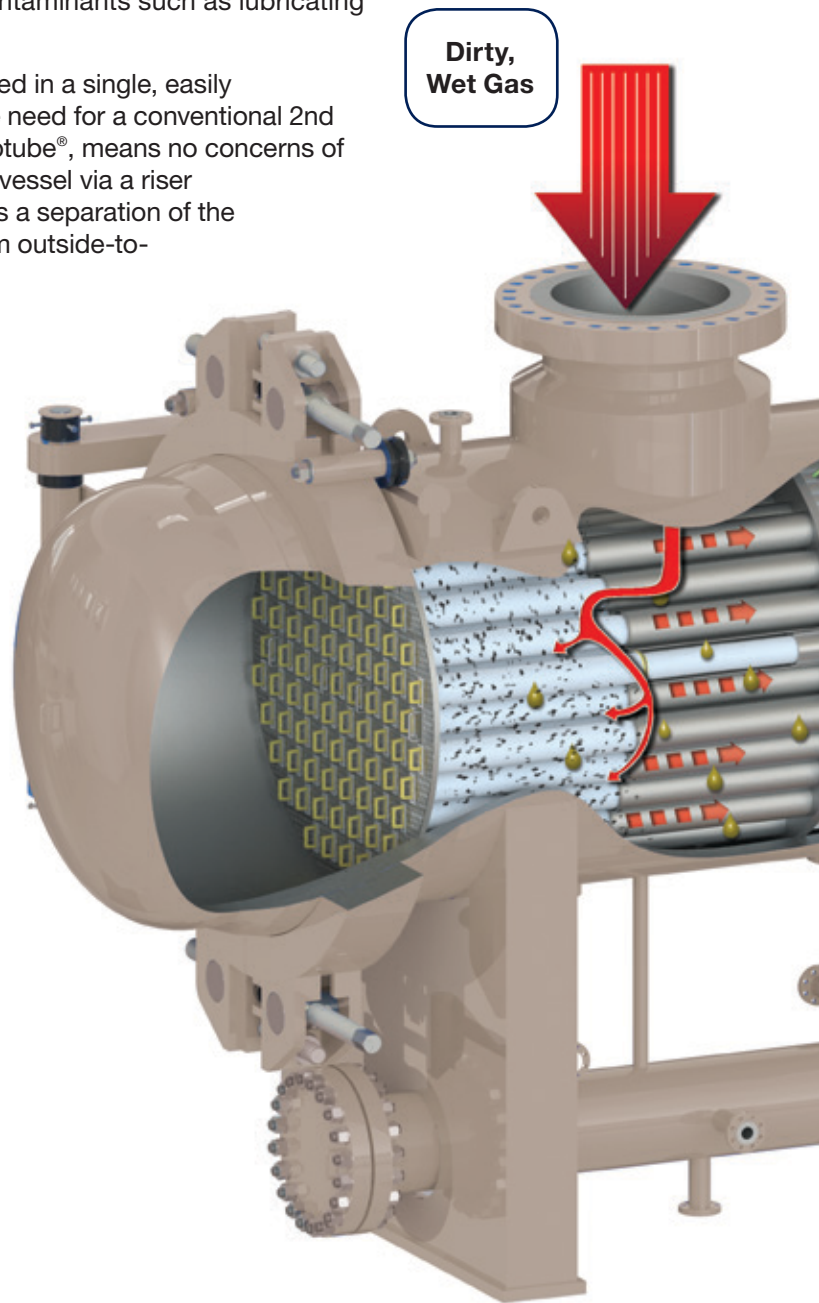

Series GEM2

Stock units are available from 10" through 60" diameter at 600# ANSI rating.

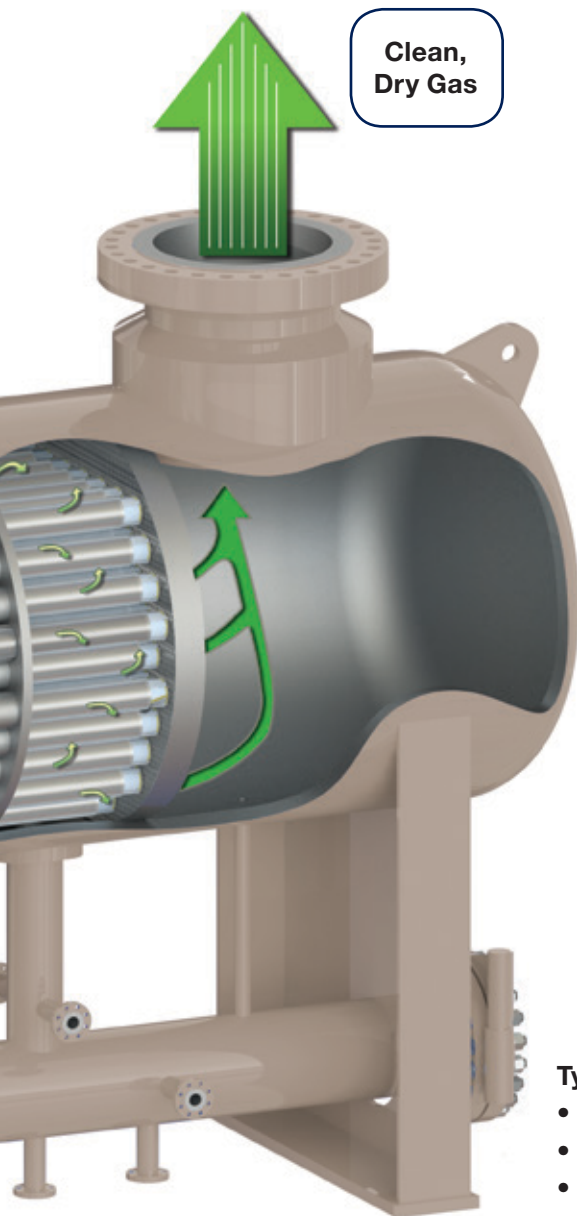

Cartridge Series PGC2

Available in polyester or polypropylene medias at various Performance Levels to handle many different kinds of coalescing applications.

The PEACH Gemini PuraSep 2 utilizes **PEACH® Gemini** (Series PGC2) cartridges. The cartridge is manufactured from PEACH technology which is a unique, patented process for making a synthetic gradient depth filter. PGC2 cartridges are rigid enough to withstand abrasion and heavy liquids, yet maintain porosity and permeability for extended contaminant removal capacity. They provide a tortuous (axial, radial and helical) flow path for the wet gas to take through the depth of the media, increasing the probability for contaminant particles to impact fibers and be captured throughout the depth of the media. They also incorporate the concept of Saturated Depth Coalescing™ to provide an open 3D depth matrix structure which allows liquids to saturate the media depth and grow to fullest potential, then drain with gravity when the droplet is ready.

Doing the work of a gas filter-separator and vertical gas coalescer combined

Typical Applications:

- Compressor Suction & Discharge
- Pre/Post Contactor
- Landfill Gas
- Propane Refrigeration System
- Solid Desiccant or Molecular Sieve Beds
- Turbine Fuel Gas
- Metering Stations
- Plant Feed
- Low NOx Burner Tip Protection
- Storage Withdrawal

WARNING: This product can expose you to chemicals including 1,3-Butadiene, Carbon Black or Nickel (Metallic) which are known to the State of California to cause cancer; or Bisphenol A (BPA) which is known to the State of California to cause cancer. For more information go to www.P65Warnings.ca.gov.



Series 77V

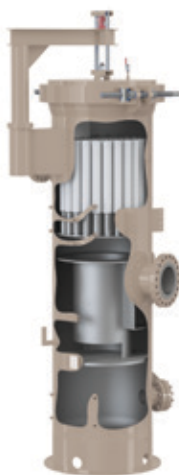

Series 77V-VKO

Spartan PuraSep® Vertical Gas Coalescers

The **Spartan PuraSep** gas coalescer is a highly efficient mist and aerosol remover down to the 0.3 micron level. **Series 77V** coalescers work best with minimal solids and low surface tension liquids such as lube oil and NGL with minimal liquid loading. Standard design includes PEACH technology Saturated Depth Coalescing cartridges, full diameter Quick Opening Closure, stilling screen and outlet baffle. Units are designed from 8” through 72” diameter and constructed in accordance with all major design codes. A **Series 77V-VKO** is available for higher liquid load capacity and utilizes a patented Vertical Knock-Out device.

Stock units are available in 8”, 16”, 26”, 34” and 48” diameters at 600# ANSI rating.

Typical Applications:

- Compressor Discharge Lube Oil Recovery
- Compressor Fuel Gas
- Molecular Sieve Bed Protection
- Process Liquid Reclaiming
- Propane Refrigeration System
- Turbine Fuel Gas

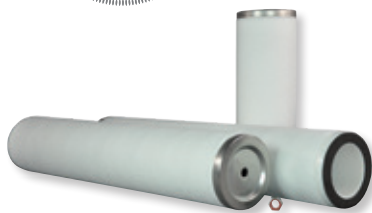

Vertical coalescers utilize **PEACH® DynaCeptor™** (Series NGGC) coalescing cartridges. The cartridge is manufactured from PEACH technology utilizing the concept of Saturated Depth Coalescing™ to provide an open 3D depth matrix structure which allows liquids to saturate the media depth and grow to fullest potential, then drain with gravity when the droplet is of the appropriate weight and size. This technology is extremely different than pleated products which have to be tight to screen down to 0.3 micron and shed the coalesced liquids off quickly to prevent high differential pressure and potential cartridge rupture.

Cartridge Series NGGC

Available in polyester or polypropylene medias at various Performance Levels to handle many different kinds of coalescing applications.



Series 89

Vertical, Small Volume Gas Coalescers

The **Series 89** gas coalescer is used for smaller volume applications with a maximum liquid loading of 8 gallons per day. They hold one coalescer cartridge and are designed and code stamped in accordance with ASME Code Section VIII Div. 1.

Stock units are available from 6” through 10” diameter at 150# ANSI rating.

Typical Application: Primary Driver Fuel Gas

WARNING: This product can expose you to chemicals including 1,3-Butadiene, Carbon Black or Nickel (Metallic) which are known to the State of California to cause cancer; or Bisphenol A (BPA) which is known to the State of California to cause cancer. For more information go to www.P65Warnings.ca.gov.



Boot-Sep™ Gas Filter-Separators for Production & Gathering

The **Boot-Sep Series GPFS** is designed specifically for the demands of the natural gas production and gathering industry providing three types of units in stock, ready for same day shipment and competitive pricing. Boot-Sep filter-separators are easy to install and maintain and come with FibrSep GX synthetic depth cartridge technology. Whether you're building a new gathering system or trying to improve the performance of existing compressors and processing equipment, the Boot-Sep is a great investment for your filtration needs!

Stock units are designed and constructed to ASME code and available in horizontal configurations in 12", 16" and 24" diameter sizes.

Typical Application: Compressor Fuel Gas



Series 85

Vertical, Small Volume Gas Filter-Separators

The **Series 85** filter-separator is used for smaller volume applications such as fuel gas conditioning filtration for compressors and engines used throughout the industry. They are designed and code stamped in accordance with ASME Code Section VIII Div. 1.

Stock units are available from 6" through 10" diameter at 150# ANSI rating.

Typical Application:
Compressor Fuel Gas

FibrSep™ GX (Series FGX) cartridges are the perfect pairing to the Boot-Sep vessel. The cartridges provide an upgrade in filtration performance from traditional fiberglass cartridges at an economical price point. FibrSep GX is a great choice for those changing cartridges on a scheduled maintenance versus maximum differential pressure.



Cartridge Series FGX
Available in polyester media at 1 micron filtration.

PEACH® DynaSep™ (Series PCHG) cartridges are used in the Series 85 filter-separator. This PEACH technology cartridge is a great choice for removing deformable and shear-sensitive contaminants found in natural gas applications. The rigid structure maintains an open porosity and permeability, while the tortuous flow path increases the probability for contaminants to impact filter fibers.

Cartridge Series PCHG
Available in polyester and polypropylene medias at 0.1, 0.3, 0.5, 1, 5 and 10 micron filtration.



WARNING: This product can expose you to chemicals including 1,3-Butadiene, Carbon Black or Nickel (Metallic) which are known to the State of California to cause cancer; or Bisphenol A (BPA) which is known to the State of California to cause cancer. For more information go to www.P65Warnings.ca.gov.

Titan PuraSep®

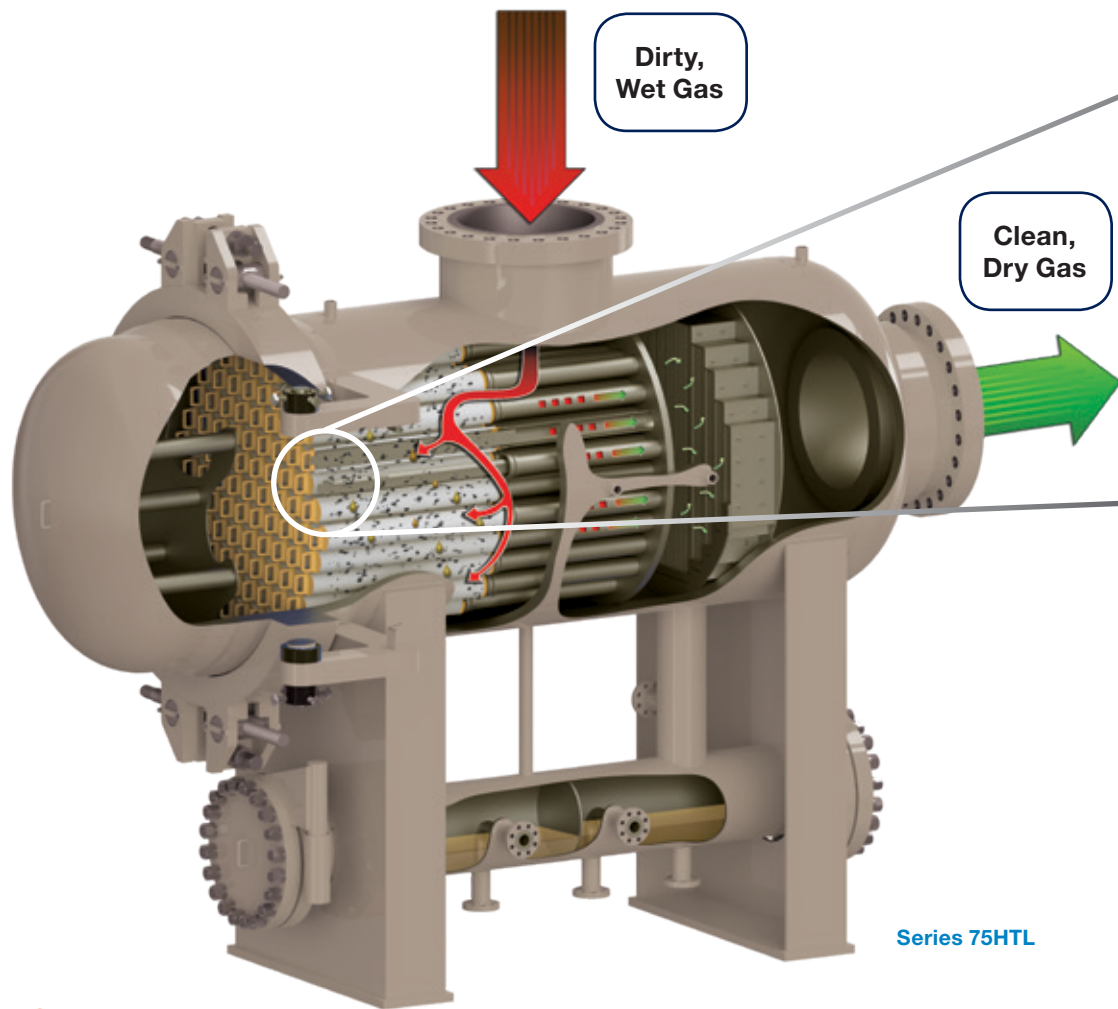

Gas Filter-Separators

Filter-Separator technology was introduced by PECO in 1953 and has been an integral part of the industry ever since.

Parker now takes the PECO design to a whole new level, once again demonstrating our commitment to provide the best possible technology to our customers.

The **TITAN PuraSep** is the first of its kind quick change filter-separator **Series 75** or dry gas filter **Series 70**. This new design truly revolutionizes the product and promotes Parker's direction of launching products that are safer, faster and easier to operate as well as provide value in reducing overall operational/maintenance costs for our customers. The design incorporates **EZ-Align®** to greatly reduce cartridge change-out time by 85% or more compared to the traditional design.

Sizes range from 10" through 84" diameter at 600# ANSI rating in horizontal and vertical configurations.

Typical Applications:

- Compressor Suction
- Landfill Gas
- Gas Storage
- Pre/Post Contactor
- Plant Feed
- Withdrawal

Patent Pending

* Change-out time reduction based on a comparison of a 48" TITAN PuraSep design and a 48" traditional filter-sep design (using double open end cartridges with washer/nut/thread assemblies). Does not include closure opening or closing time.

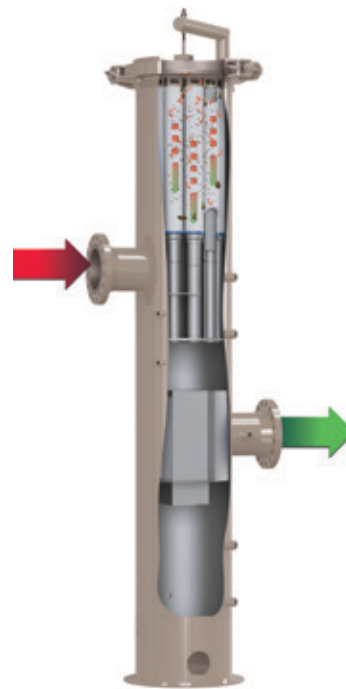
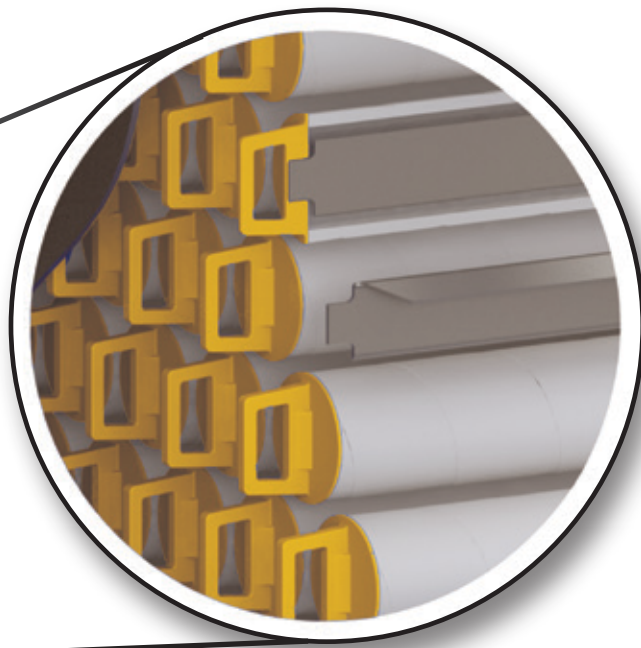

Series 75VTL

Reduce cartridge change-out time by 85% or more*

Features & Benefits

- **Two Stage Design**
 - 1st stage removes bulk liquids and particulate
 - 2nd stage removes coalesced liquids
- **Full End Closure**
 - Minimizes confined space entry
- **Backflow Plate**
 - No tools required to remove
 - Permanently fixed in closure
 - Ensures cartridge installed correctly
 - Prevents cartridge from unseating
- **EZ-Align®**
 - Holds cartridge concentric to riser
 - Prevents cartridge sagging
 - Allows for quick change-out of cartridges
 - Ensures cartridge sealing
- **Gas Entry on Pipe Risers**
 - Knocks out bulk liquids
 - Decreases turbulent gas entry
 - Protects cartridges from damage
- **Redesigned Cartridge End Caps**
 - No tools required to install or remove cartridges
- **Advanced Cartridge Technology**
 - PEACH depth, helical style design
 - Pleated, large surface area style design
- **High Performance Mist Extraction Device**
 - Unique “wave” vane profile
 - Resists plugging by semi-solid contaminants
- **Dual Downcomers to 1st Stage Sump**
 - Eliminates vapor locking during upset conditions



Cartridge Series EZ-PCHG

Available in polyester and polypropylene medias at 0.1, 0.3, 0.5, 1, 5 and 10 micron filtration.

PEACH® DynaSep™ (Series EZ-PCHG) cartridges are used in the TITAN PuraSep filter-separator. This PEACH technology cartridge is a great choice for removing deformable and shear-sensitive contaminants typically found in natural gas applications. The rigid structure maintains an open porosity and permeability, while the tortuous flow path increases the probability for contaminants to impact filter fibers.

WARNING: This product can expose you to chemicals including 1,3-Butadiene, Carbon Black or Nickel (Metallic) which are known to the State of California to cause cancer; or Bisphenol A (BPA) which is known to the State of California to cause cancer. For more information go to www.P65Warnings.ca.gov.

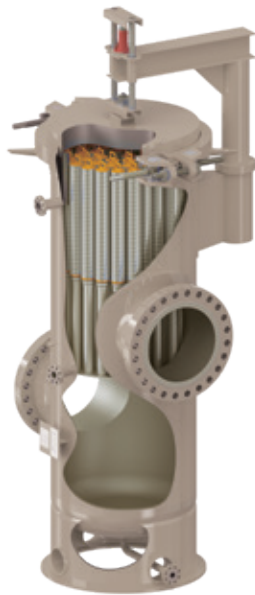

Series 70VTL

Titan PuraSep® Dry Gas Filters

The **Series 70** dry gas filters are now part of the **TITAN PuraSep®** line which provides a quick change-out of cartridges through the incorporation of **EZ-Align®**. The filter is designed to handle a variety of applications to remove dry, solid contaminants.

Sizes range from 6" through 84" diameter at 600# ANSI rating in horizontal and vertical configurations.

Typical Applications:

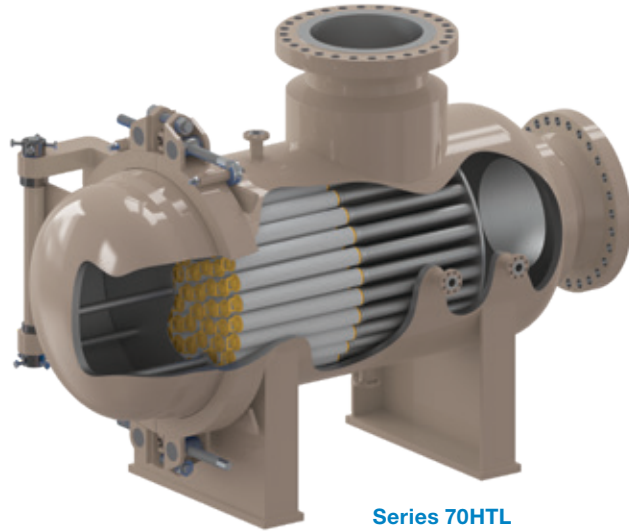

Series 70HTL

TruGard™ (Series EZ-PSFG) cartridges are recommended for use in the TITAN PuraSep dry gas filter if dry, solid particulates, that are not shear-sensitive, are present. TruGard has an optimized pleat design which provides a high surface area for contaminant removal. Rigid, solid particles form a cake on the upstream side of the pleats.



Cartridge Series EZ-PSFG

Available in polyester and polypropylene medias at 0.5, 1, 5, 10, 20 and 50 micron filtration.

PEACH® DynaSep™ (Series EZ-PCHG) cartridges are recommended for use in the TITAN PuraSep dry gas filter if iron sulfide/black powder particulate is present. These types of contaminants are extremely shear-sensitive and are better removed through the use of PEACH technology depth filtration.



Cartridge Series EZ-PCHG

Available in polyester and polypropylene medias at 0.1, 0.3, 0.5, 1, 5 and 10 micron filtration.



WARNING: This product can expose you to chemicals including 1,3-Butadiene, Carbon Black, Formaldehyde, Nickel (Metallic), which are known to the State of California to cause cancer, or Bisphenol A (BPA) which is known to the State of California to cause birth defects or other reproductive harm. For more information go to www.P65Warnings.ca.gov.

In-Line Dry Gas Filters

Typical Applications:

- Clean, Dry Fuel Gas
- Instrument Air
- Turbine Meters
- City Gates
- Regulator Stations

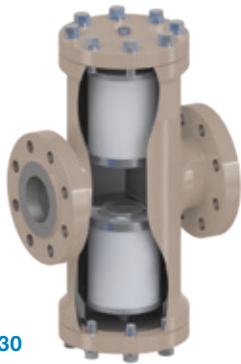

Series 30

- Dry gas pipelines
 - Molecular Sieve Bed Discharge
- Series 30** is a cast steel design available in 2", 3" and 4" flange connections at 150#, 300# and 600# ANSI ratings.



Series 30F

Series 30F is a fabricated steel design available in 2" through 12" flange connections at 150#, 300# and 600# ANSI ratings and is designed in accordance with ASME Code Section VIII Div. 1.

GritGard™ cartridges are constructed of pleated media to trap rigid, solid particles and aid in building a "filter cake". Flow is outside-to-inside and with compression spring sealing.



Cartridge Series PEPP & PEPS

Available in polyester or cellulose medias from 2 micron to 20 micron.

A unique PEACH version of this cartridge is available in our **DynaGard™** Series for handling shear-sensitive contaminants or for providing greater durability versus pleats.



Cartridge Series PCHG-6-3.12 & PCHG-6-7.18

PleatGard™ cartridges are constructed of pleated media to trap rigid, solid particles and aid in building a "filter cake". Cartridges are similar to a bag design flowing inside-to-outside and trapping contaminants on the inside. This leaves the vessel clean once the cartridge is removed.

Cartridge Series

PS-559, PS-5519, PS-819

Available in polyester media from 2 micron to 20 micron.

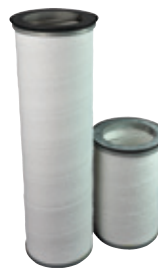

Cartridge Series PCHG-30F

A unique PEACH version of this cartridge is available in our **DynaGard™** Series for handling shear-sensitive contaminants or for providing greater durability versus pleats.

Vane Style - Gas Separators & Scrubbers

The **Series 95** vane mist extractor can be found throughout the industry as production separators, three phase separators, knock-out drums and in a variety of other applications where liquid removal is required. The Series 95 uses the proprietary Wave Plate Vane mist extractors for high efficiency, reliable, free liquid and aerosol mist removal. Units are available in a Separator design where inlet and outlet connections are in-line or in a Scrubber design where inlet and outlet connections are alt-line which allows for the handling of slugs of liquid.

Sizes range from 12" through 120" diameter up to 600# ANSI rating in vertical and horizontal configurations.

Typical Applications:

- Processing Plant Feed
- Metering Stations
- Gas Storage
- Compressor Stations
- Regulator Stations
- Natural Gas Power Plants

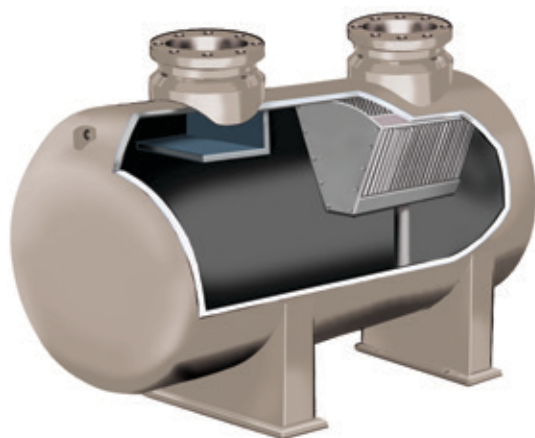

Series 95H-VBANK
Scrubber



Series 95V
Separator



Series 95SV
Scrubber

WAVE PLATE VANES

The Wave Plate Vane provides a controlled change of direction for the gas stream. Liquid droplets impinge upon the vane plates and become trapped in individual drain passages where they collect and coalesce until heavy enough to drain out by gravity.

- 98% efficiency of liquid droplets 8-10 microns and larger
- High liquid loading capability
- Best for removing hydrocarbon liquids and water
- 4 to 1 turndown ratio

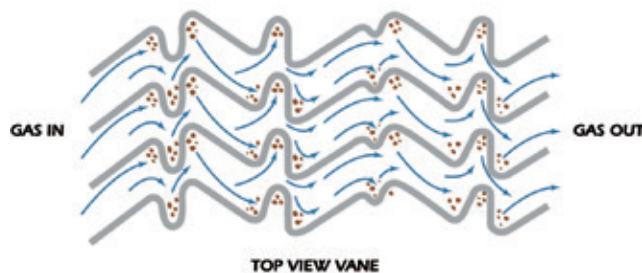
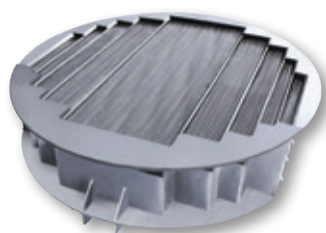

WARNING: This product can expose you to chemicals including 1,3-Butadiene or Carbon Black which are known to the State of California to cause cancer. For more information go to www.P65Warnings.ca.gov.

Cyclotube® Style - Gas Separators & Scrubbers

The **Series 95-CT** proprietary two stage vertical tube separation system has proven to yield high efficiencies for mechanical or non-disposable separation devices. The **Cyclotube** is used in numerous gas streams for bulk liquid separation and offers a higher efficiency option to vanes. They have a lower susceptibility to plugging and work well with low surface tension “crawling” type liquids. Units are available in a Separator design where inlet and outlet connections are in-line or in a Scrubber design where inlet and outlet connections are alt-line which allows for the handling of slugs of liquid.

Sizes range from 12” through 120” diameter up to 600# ANSI rating in vertical and horizontal configurations.

Typical Applications:

- Compressor Interstage
- Metering Stations
- Regulator Stations

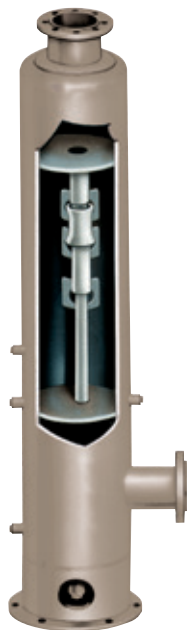

Series 95V-CT Separator

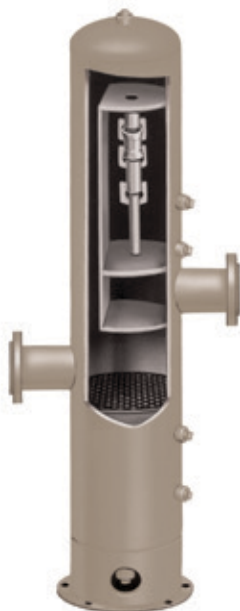

Series 95SV-CT Scrubber

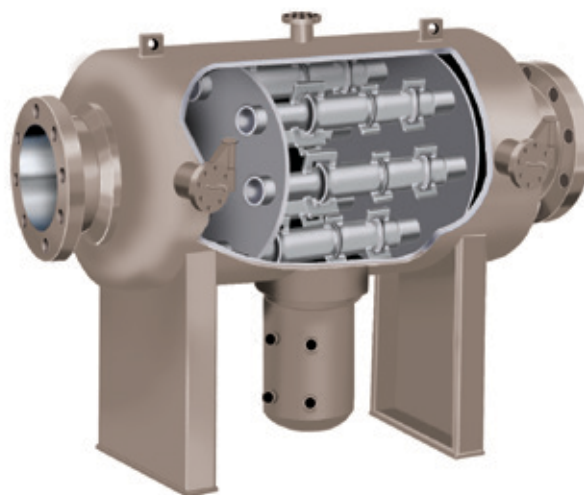

Series 95H-CT Separator

CYCLOTUBE®

The Cyclotube takes the incoming gas stream and applies a centrifugal motion to it which separates particles from the gas. The inertia imparted upon the liquid particles by the swirling motion forces them to the outer wall, where they are ejected into a quiescent zone for removal.

- 98% liquid droplets 3-5 microns and larger
- Best for removing lube oil, glycol, paraffin, brine, asphaltenes
- Low susceptibility to plugging
- Highest efficiency on “crawling” liquids and low surface tension liquids
- 4 to 1 turndown ratio

WARNING: This product can expose you to chemicals including 1,3-Butadiene or Carbon Black which are known to the State of California to cause cancer. For more information go to www.P65Warnings.ca.gov.

Vertical Knock-Out Gas Cyclone Separators

The **Series 95VKC** (Vertical Knockout Cyclone) is a rugged, bulk solids removal, gas separator. The Series 95VKC is designed to handle high flow rates and a larger volume of solids than a typical cyclone separator. The vertical knockout cyclone resists plugging in the presence of wet solids and operates at a lower pressure drop than other cyclone separators. The unit is designed to remove greater than 85% of 10 micron and larger contaminant, up to 40,000 ppm in the influent. Removing solids from the sump is easy with clean-out valves or a manway to facilitate the removal.

The Series 95VKC can be used upstream of dry gas filters to reduce the cartridge change-out frequency for black powder or other high solids loading applications. The Series 95VKC has a turndown ratio of 4 to 1.

Typical Applications:

- Large diameter pipeline compressor inlet
- Protection against pigging operation



Series 95VKC



Series 95V-MC

Mini-Cyclone Gas Separators

The **Series 95V-MC** (Mini-Cyclone) is a liquid or solids cyclonic gas separator. The Series 95V-MC offers a high efficiency, contaminant removal system that will remove dry solids in the gas stream up to 600 ppm(w) and free liquids to 20,000 ppm. The Series 95V-MC provides a rated efficiency for 100% removal of dry solid particles 8 micron and larger. For a liquid mist the Series 95-MC will remove 100% of the liquid particles 5 micron and larger including low surface tension liquid contaminants. The Series 95V-MC has a turndown ratio of 4 to 1.

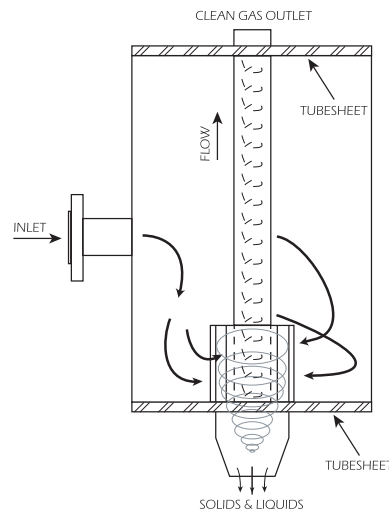

Typical Applications:

- Upstream of fuel gas coalescer
- Upstream of storage gas withdrawal locations
- Upstream and downstream of amine and glycol contact towers

WARNING: This product can expose you to chemicals including 1,3-Butadiene or Carbon Black which are known to the State of California to cause cancer. For more information go to www.P65Warnings.ca.gov.

Auto-Cleaning Metallic Filters

For Gas & Liquid Applications



For high temperature applications or harsh chemical environments, Parker provides full metallic solutions for gas/solid and liquid/solid separation based on sintered media technologies. The sintered metal cartridges can withstand temperatures up to 1450°F and filters contaminants on its media surface which then builds a “cake” to achieve efficiencies up to 99.9% at 1 micron.

The vertical, skid mounted units offer continuous, maintenance free operation through a backflushing or backpulsing sequence to remove the contaminant (“cake”) from the sintered metal cartridges.

Metallic systems can be used in the following applications where catalyst recovery, product recovery, particulate matter emissions monitoring and environmental regulations are required.

- Oil Refining – FCC or CCR hoppers, FCC regenerator flue gas, FCC slurry oil
- Petrochemicals – PP, PE, EDC, PTA/CTA
- Ore Smelting – Cu, Al, Pt, Ni
- Gasification – coal, biomass
- Nuclear
- Fine Chemicals

Engineered Filtration & Separation Skid Packages

Parker offers custom, complete packaged skid units which can be equipped to include a variety of PECO filtration equipment coupled with instrumentation, valves, piping, electrical, insulation, etc., to be ready for “Plug and Play” installation at the job-site.

The skid packages can be arranged in a variety of configurations in order to satisfy our customer’s needs. Please consult the factory for more information regarding skid packages.



- Fuel Gas Filtration Skids
- Duplex Filtration Skids
- Portable
- Efficient
- Cost Effective
- Turn Key
- Custom Design

WARNING: This product can expose you to chemicals including 1,3-Butadiene or Carbon Black which are known to the State of California to cause cancer. For more information go to www.P65Warnings.ca.gov.

BlastPure[®]

Auto-Clean Water Filtration System

For High Contaminant Loads >1000 ppm

BlastPure Series BPM water filtration systems are self-contained and field proven to remove heavy concentrations of bulk solids and semi-solids from a water stream without the use of consumable bags or cartridges. Automatic continuous operation and media cleaning are driven by an industrial rated micro-controller. Operation can be easily adjusted through a locally mounted HMI screen.

BlastPure utilizes a cyclonically aided filtration system designed to minimize backflushing cycles and waste generation. The filtration system employs a unique backflush that literally “blasts” the system’s stainless steel filter media clean of the most troublesome fouling type contaminants during the cleaning cycle.

BlastPure can be sized for any water filtration application and can be employed as permanent facility units or as mobile units for flow back sites or other field operation services. The systems can handle a contaminant concentration up to 20% with removal levels from 100 to 500 microns available.

Typical Applications:

- Pre-frac water filtration
- Final stage water polishing filtration
- Injection pump and reservoir protection
- Truck off-load service
(handling heavily fouled water loaded with gel, oil, and drilling mud)



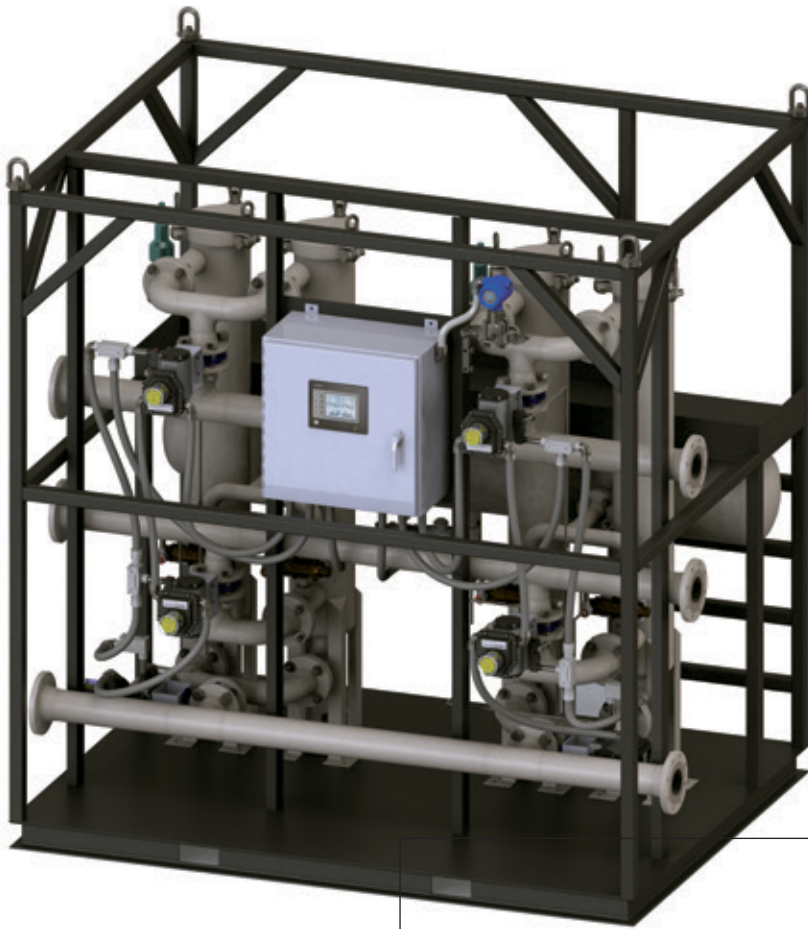

Series BPM 14

14 Barrels/Minute

- Modular Design
- Manual or Automatic Options
- Built-In Ladder and Platform

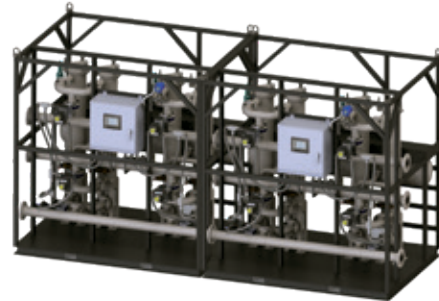

Modules can be connected for increased flow capacity.

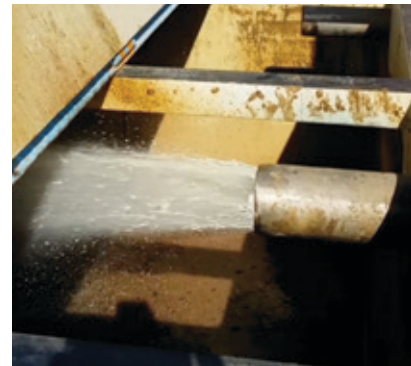

The pictures above show the backflush cleaning process of the BlastPure system. The dirty, contaminated water is literally blasted off the metallic filter cartridges during the cleaning cycle. The water color coming out from the blast goes from dark to clear as the filter cartridges are cleaned and prepared to be put back online.

XtreamPure®

High Flow Capacity & High Contaminant Loading Liquid Filters

The **XtreamPure** vessel and cartridge line removes particulate in liquid applications with flow rates over 200 gpm. It provides high capacity filtration for virtually any liquid application by utilizing large 6" diameter cartridges in 40", 60" and 80" lengths with a variety of material choices for compatibility and performance needs. The inside-to-outside flow through the cartridge ensures contaminant is captured within the cartridge allowing a cleaner cartridge extraction during change-outs.

Sizes range from 10" through 84" diameter up to 600# ANSI rating in horizontal and vertical configurations.

Stock units are available in 10" and 18" diameter at 150# and 600# ANSI ratings.

Typical Fluids Filtered:

- Amine
- Condensate
- Final Products
- Glycol
- Hydrocarbons
- Lube Oil
- Water

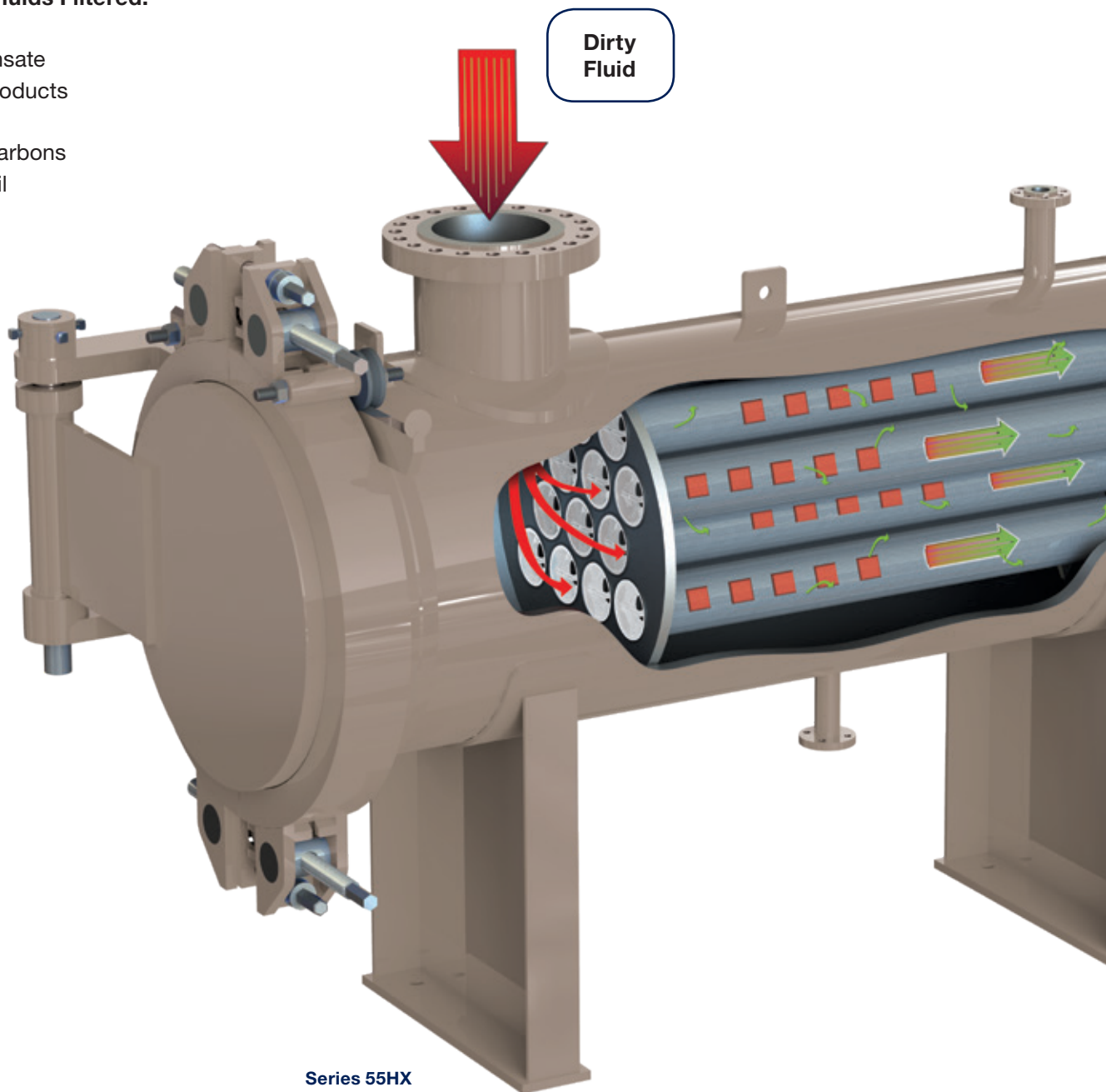

Series 55HX

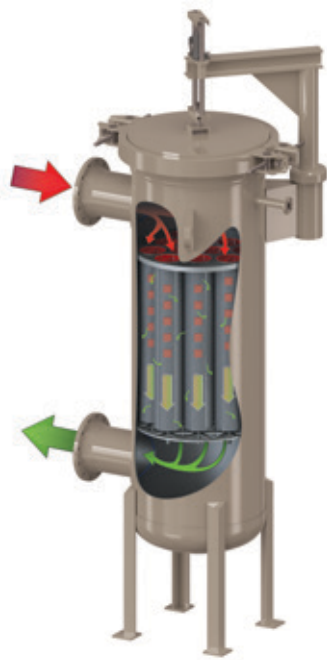

Series 55VX

Features & Benefits

- **User Friendly Design**
 - No tools required to change out cartridges
- **Full End Closure**
 - Minimizes confined space entry
- **Large Diameter Cartridges**
 - Allows for high flow rates so less cartridges needed in vessel versus conventional 2.5"OD style and reduced vessel diameter
 - High contaminant loading capacity
- **Flow Direction**
 - Inside-to-outside flow direction through cartridge keeps contaminants within the cartridge providing a cleaner vessel during cartridge removal
- **Cartridge Basket Supports**
 - Protect and support cartridges
 - Can be replaced in the event necessary
- **Wide Range of Cartridge Styles**
 - Pleated, PEACH® Depth, Bags, Strainers



Clean Fluid

Cartridge Series XP

Available in different styles with various media choices for best contaminant removal selection.

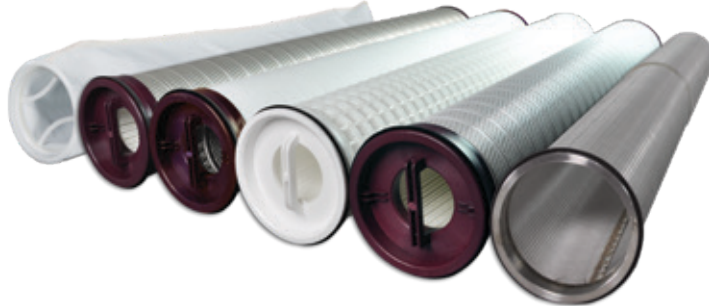

XstreamPure (Series XP) cartridges offer a complete line of different styles to choose from depending on your fluid streams temperature, compatibility and cleanliness needs. The offering includes:

- Pleated Style in glass, polyester, polypropylene and cellulose medias
- PEACH Depth Style in polyester or polypropylene medias
- Bag Style in polyester or polypropylene medias
- Strainer Style in stainless steel material

WARNING: This product can expose you to chemicals including 1,3-Butadiene, Carbon Black, Formaldehyde, Nickel (Metallic), or Glass Wool which are known to the State of California to cause cancer, or Bisphenol A (BPA) which is known to the State of California to cause birth defects or other reproductive harm. For more information go to www.P65Warnings.ca.gov.

Chemelean®

Economy Liquid Filters for Flow Rates up to 200 gpm

The **Chemelean** vessel and cartridge line offers versatility to adapt to a wide variety of process liquid applications up to 200 gpm. The vessel comes in two sizes to hold either a 20" length cartridge or 40" length cartridge. Chemelean cartridges come in a wide range of media choices for suitable fluid compatibility.



Series 55C
with Legs

Stock units are available in 8" diameter at 150# ANSI rating.

2" NPT standard connections with option for changing to 2" flange connections.

Dual rated: 275 psig at 250°F without corrosion allowance and 150 psig at 250°F with 1/8" corrosion allowance.

Typical Fluids Filtered:

- Amine
- Condensate
- Final Products
- Glycol
- Hydrocarbons
- Lube Oil
- Water



Series 55C
with Saddles

LONG LIFE ALTERNATIVE TO BAG VESSELS!

Contaminant Loading Comparison

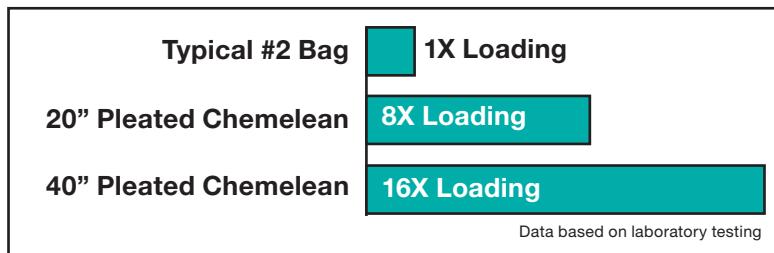

Tired of changing out bag filters so often? Before you buy your next bag filter vessel, consider purchasing a Chemelean filter vessel instead!

Chemelean filters provide excellent contaminant loading so cartridge change-out typically becomes less frequent than a bag...and that keeps your process up and running!

Cartridge Series CM

Available in pleated polypropylene, polyester, glass or cellulose and PEACH® polyester or polypropylene.

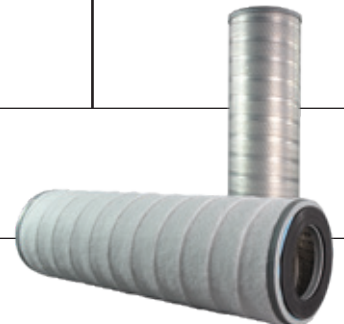

WARNING: This product can expose you to chemicals including 1,3-Butadiene, Carbon Black, Formaldehyde, Nickel (Metallic), or Glass Wool which are known to the State of California to cause cancer, or Bisphenol A (BPA) which is known to the State of California to cause birth defects or other reproductive harm. For more information go to www.P65Warnings.ca.gov.

XtreamSorb®

PECO carbon vessels utilize high quality activated carbon to adsorb dissolved liquid impurities from process streams such as air, gas, water, amine and glycol. Removal of these impurities is critical to prevent problems such as foaming, odor and contaminant build up.



Series 14

Cartridge Series XS

Liquid Adsorber using Carbon Block & PEACH®

The **Series 14** uses a cartridge combination of porous, extruded carbon block and outer PEACH filter sleeve. This form of activated carbon maximizes hydrocarbon removal efficiency and limits carbon fines into the fluid stream. The PEACH sleeve filters particulate and absorbs hydrocarbons, extending the on-stream life of the carbon block it encases. The cartridge design provides an additional benefit in that it is lighter weight than a traditional carbon canister. Diameters from 14" through 66" are available to all major codes with 1/8" corrosion allowance. The Series 14 typically offers a smaller footprint compared to a Series 10 under the same design conditions.

Liquid Adsorbers using Granular Activated Carbon



Series 10
with Canisters

The **Series 10** uses activated carbon canisters to allow fast, easy change-outs through a full diameter Quick Opening Swing-Bolt Closure. Diameters from 14" through 66" are available to all major codes with 1/8" corrosion allowance. Stock Units are available in 14", 24" and 36" diameter at 150# ANSI rating.

The **Series 10FB** uses a fixed bed of activated carbon beneficial for large liquid and gas purification services. The 10FB utilizes an outlet header lateral system to eliminate bed channeling and carbon fine discharge. Diameters from 24" through 140" are available to all major codes with 1/8" corrosion allowance.



Series 10FB
Fixed Bed



CarboMax™ Canisters

Activated carbon bound in a canister form is a safe, easy to manage, and economical way to effectively remove dissolved impurities from process streams such as amine and glycol systems. Parker uses the highest quality activated carbon making sure that high efficiency adsorption is achieved.

CarboMax™ Bulk

Loose activated carbon and non-activated support carbon for fixed bed style vessels. Available in 4x12 and 8x30 mesh sizes.

WARNING: This product can expose you to chemicals including 1,3-Butadiene, Carbon Black or Nickel (Metallic) which are known to the State of California to cause cancer, or Bisphenol A (BPA) which is known to the State of California to cause birth defects or other reproductive harm. For more information go to www.P65Warnings.ca.gov.

XtreamPhase®

Two-Stage Liquid/Liquid Phase Coalescers

The **Series 110V** vertical coalescer and **Series 110H** horizontal coalescer utilize first stage hydrophilic coalescer cartridges and second stage hydrophobic separator cartridges to perform liquid/liquid separation. The two-stage design handles immiscible liquids with an inlet concentration up to 5% by volume (50,000 PPMV) and removes free and entrained water down to 10 PPMV or less. Designs are available from 14" through 60" diameter.



Series 110V

Separation of free and entrained water from:

- Aromatics
- Condensate
- Diesel
- Gasoline
- Kerosene
- LPG
- Lube Oil

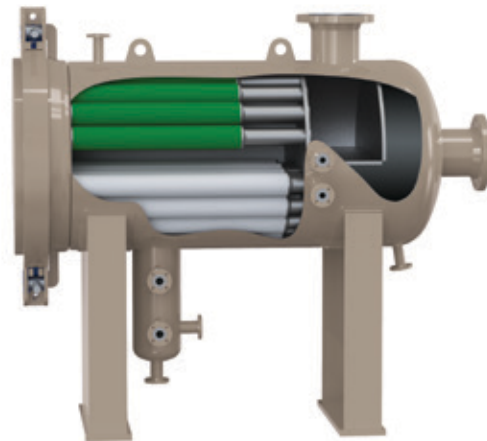

Series 110H



XtreamPhase®

DOE Style, Coalescer Cartridge Options

- Series C depth glass coalescer
- Series IPC depth glass coalescer w/ internal pleat pack
- Series PLPC depth PEACH coalescer
- Series TLPC pleated Timlar™ fluoropolymer coalescer

XtreamPhase®

DOE Style, Separator Cartridge Options

- Series S resin impregnated pleated cellulose separator
- Series S-SH synthetic hydrophobe screen separator
- Series S-TF teflon coated screen separator



XtreamPhase®

Single-Stage Liquid/Liquid Phase Coalescers

The single-stage **Series 110HXP** and **110HRXP** utilize hydrophilic coalescer high flow style cartridges to coalesce a discontinuous phase fluid from a continuous phase fluid. The single-stage **Series 110H** and **110HR** do the same thing except utilize a wafer pack instead of cartridges. The vessel length is designed to provide enough settling distance after the coalescer cartridge or wafer pack to allow for coalesced droplets to separate from the continuous phase fluid. In this design the difference in density between the two fluids needs to be at least 20%. The single-stage design handles immiscible liquids with an inlet concentration up to 10% by volume (100,000 PPMV). Removal of the discontinuous phase fluid down to 15-20 PPMV is achieved using the coalescer cartridge style. When using wafer packs, the removal level will vary from 15 to 75 PPMV depending upon the wafer pack material chosen. Designs are available from 8" through 84" diameter. Three Phase Separator designs are also available.

Separation of:

- Amine from Hydrocarbons
- Caustic from Fuels
- Free Water from Hydrogen Peroxide
- Hydrocarbon from Quench Water
- Oil from Ammonia
- Oil from Water

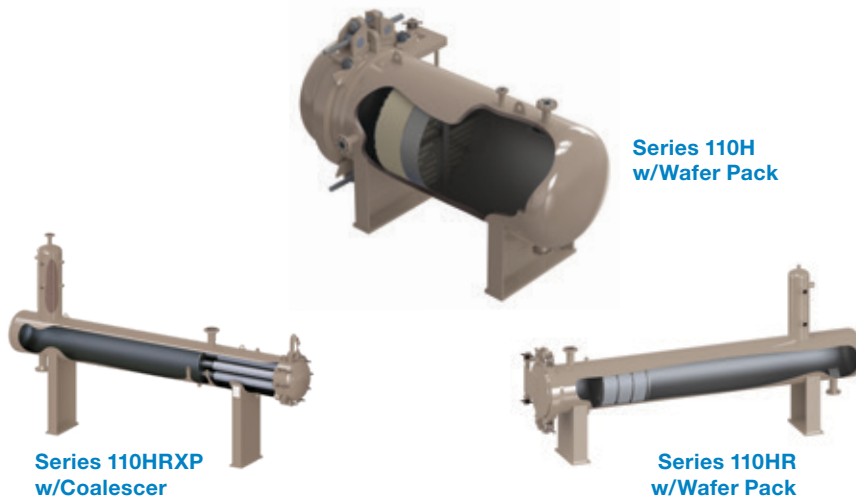

XtreamPhase® High Flow Style, Coalescer Cartridge Options

- Series XPLC-C depth glass coalescer
- Series XPLC-IPC depth glass coalescer w/ internal pleat pack
- Series XPLC-HCP depth Hot/Chem PEACH coalescer
- Series XPLC-PLPC depth PEACH coalescer
- Series XPLC-TLPC pleated Timlar™ fluoropolymer coalescer

XtreamPhase® Packs Wafer Shaped Mass Packed Coalescing Media Options

- Excelsior (wood)
- Fiberglass
- Stainless Steel Wool

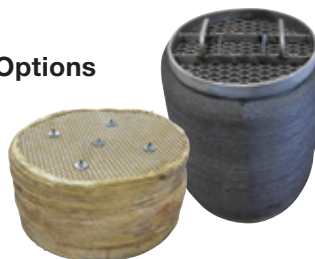

WARNING: This product can expose you to chemicals including 1,3-Butadiene, Carbon Black, Formaldehyde, Nickel (Metallic), or Glass Wool which are known to the State of California to cause cancer, or Bisphenol A (BPA) which is known to the State of California to cause birth defects or other reproductive harm. For more information go to www.P65Warnings.ca.gov.

GLOBAL OIL & GAS FILTRATION OFFICES

North America

USA Oil & Gas Filtration

Mineral Wells, TX
940-325-2575
industrialprocess.na@parker.com

Canada Oil & Gas Filtration

Calgary, Canada
403-717-2891
industrialprocess.na@parker.com

Asia Pacific

Malaysia Oil & Gas Filtration

Kuala Lumpur, Malaysia
+603-8941-2366
IPF_Malaysia@parker.com

Korea Oil & Gas Filtration

Gyeonggi-do, Korea
+82-31-359-0782
KFDsales@parker.com

Europe & Middle East

Europe Oil & Gas Filtration

United Kingdom
+44 (0)191-402-9200
peco.emea@parker.com

Middle East Oil & Gas Filtration

Dubai, UAE
+971-4-886-5401
peco.emea@parker.com

Latin America

Latin America Oil & Gas Filtration

São José dos Campos, Brazil
+55-12-4009-3500
falecom@parker.com



© 2019 Parker Hannifin Corporation
CAT-OG-GENPRODUCTS-PECO-191101

Parker Hannifin Corporation
Industrial Process Filtration Division
www.parker.com/ipf

