



TRUCK HYDRAULICS PUMPS AND MOTORS

Series GPA, GP1, F1, T1, F2, F3, F4, VP1
Fixed and Variable Displacement Pumps,
Motors and Accessories

Basic formulas for hydraulic pumps

Flow (q)

$$q = \frac{D \times n \times \eta_v}{1000} \quad [\text{l/min}]$$

Torque (M)

$$M = \frac{D \times \Delta p}{63 \times \eta_{hm}} \quad [\text{Nm}]$$

Power (P)

$$P = \frac{q \times \Delta p}{600 \times \eta_t} \quad [\text{kW}]$$

D – displacement [cm³/rev]

n – shaft speed [rpm]

η_v – volumetric efficiency

Δp – differential pressure [bar]
(between inlet and outlet)

η_{hm} – mechanical efficiency

η_t – overall efficiency
($\eta_t = \eta_v \times \eta_{hm}$)

Conversion factors

1 kg	2.20 lb
1 N.....	0.225 lbf
1 Nm	0.738 lbf ft
1 bar	14.5 psi
1 l	0.264 US gallon
1 cm ³	0.061 cu in
1 mm.....	0.039 in
$\frac{9}{5} \text{ }^\circ\text{C} + 32$	1°F
1 kW.....	1.34 hp



WARNING – USER RESPONSIBILITY

FAILURE OR IMPROPER SELECTION OR IMPROPER USE OF THE PRODUCTS DESCRIBED HEREIN OR RELATED ITEMS CAN CAUSE DEATH, PERSONAL INJURY AND PROPERTY DAMAGE.

- This document and other information from Parker-Hannifin Corporation, its subsidiaries and authorized distributors provide product or system options for further investigation by users having technical expertise.
- The user, through its own analysis and testing, is solely responsible for making the final selection of the system and components and assuring that all performance, endurance, maintenance, safety and warning requirements of the application are met. The user must analyze all aspects of the application, follow applicable industry standards, and follow the information concerning the product in the current product catalog and in any other materials provided from Parker or its subsidiaries or authorized distributors.
- To the extent that Parker or its subsidiaries or authorized distributors provide component or system options based upon data or specifications provided by the user, the user is responsible for determining that such data and specifications are suitable and sufficient for all applications and reasonably foreseeable uses of the components or systems.

Offer of Sale

Please contact your Parker representation for a detailed "Offer of Sale".

Table of Content

General Information	4
Pump and Line selection	14
GPA and GP1 Pumps	18
F1 Pump, ISO	24
F1 Pump, SAE.....	34
T1 Pump.....	37
F1 Motor	41
F2 Twin-flow Pump	43
F3 Pump.....	46
F4 Pump.....	51
VP1 Pump	57
Auxiliary Valves	73
Accessories.....	83
Installation and start up	89



If you have questions about the products contained in this catalogue, or their applications, please contact:
Parker Hannifin EMEA Sàrl European Headquarters
parker.com/msgc

GENERAL INFORMATION

GPA and GP1 Pumps

Light/medium duty pumps

Parker's truck gear pumps are ideal for operators of light trucks for their hydraulic power needs.

The GPA/GP1 series gear pumps are available to suit most applications. They are light and compact, and can be installed in either rear or side mount configuration thanks to their unique dual port layout.

The smaller GPA series is built with an extruded aluminum housing for minimum weight.

The larger GP1 pumps are built with compact cast iron housings for strength.

The gear pumps complement our heavy duty piston pumps and vane pumps.

The performance and characteristics are ideal for many light and/or intermittent applications, including the famous Parker reliability, and they are engineered with a long, trouble-free service life.

Features

- Compact and light weight – easy to install even on small vehicles
- Quiet operation – low noise emissions are important in sensitive areas
- Robust and reliable – means a long, trouble-free service life
- Built for high rpm's – less sensitive to over-speeding
- Bi-directional – easy to install
- Side or rear mount – use the ports on the side or at the rear, whichever is most suitable for the application.

See page 18



Find more information on the GP1 product page.



Find more information on the GPA product page.



Series GPA



Series GP1

F1 Pump ISO

Series F1 is a further development of our well known 'truck pump', the F1. The F1 offers many additional values for operators of cargo cranes, hook loaders, skip loaders, forest cranes, concrete mixers and similar truck applications.

Series F1 is a very efficient and straight forward pump design with unsurpassed reliability.

Its small envelope size gives a simple and inexpensive installation.

Features of the F1 are:

- High selfpriming speeds
- Operating pressures up to 400 bar
- High overall efficiency
- Low noise level
- Small installation dimensions
- Low weight

... thanks to:

- 45° bent-axis angle
- Optimal inlet port geometry in the end cap
- Single housing design
- Spherical pistons – high speeds
- Laminated piston rings – low leakage
- Positive synchronisation with timing gear
- Installation above the reservoir level possible
- Tolerates low temperatures and high temperature shocks
- Shaft end and mounting flange meet the ISO standard for all sizes

See page 24



Find more information on the F1 product page.

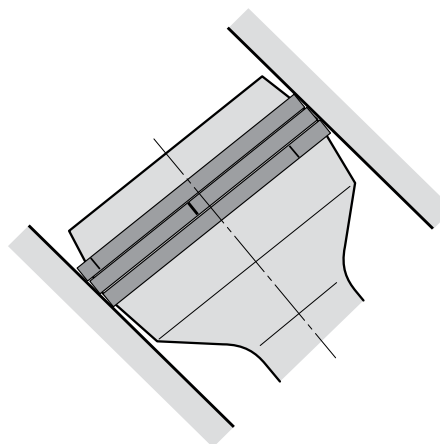

F1 piston with laminated piston ring.

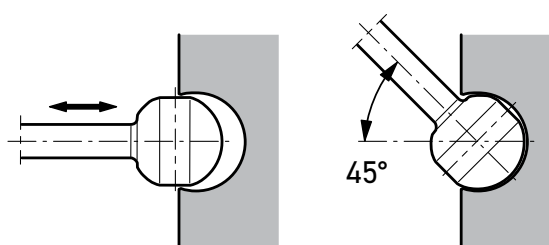

F1 piston-to-shaft locking.

F1e

The new eSeries is utilizing the high efficient bent axis concept with an increased speed range and reduced noise level. It is utilizing the highly efficient Parker bent axis design, with the unique spherical piston concept. The well proven gear synchronization and double tapered bearing concept gives a very robust and reliable pump in demanding applications, applicable for both open and closed loop systems. Combined with our well proven track record of durable pumps, we have an outstanding uptime. Improvements in pressure pulsation and high speed capability is ensuring pressure and flow performance at the highest levels of system efficiency together with lower noise emissions.

Features

- Silent operation
- Unbeatable efficiency
- High & Low speed capability
- Consistent performance over lifetime
- High pressure rating

See page 28



Find more information on the F1e product page.



Series F1e

Engineered for demanding mobile applications, the F1e delivers the same high rpm capability you expect—now with significantly lower noise and smoother system behavior.

- Up to 6 dBA less noise emissions for improved operator comfort and urban compliance.
- Up to 40% less system pulsations for smoother operation and reduced system noise.
- Same high rpm performance with the option to operate all the way down to 0 rpm for precise control.

Choose the Parker F1e for productivity, precision, and a best-in-class operator experience.

Contact your Parker representative to discuss configurations and availability.

F1 Pump SAE

Features:

- Laminated piston rings – low leakage
- Positive synchronisation with timing gear
- Operating pressure up to 350 bar
- Installation above the reservoir level possible
- Tolerates low temperatures and high temperature shocks
- Shaft end and mounting flange meet the standard SAE-B
- 4 sizes -25 / -41 / -51 / -61 cm³/rev

See page 34



Find more information on the F1 pump product page.

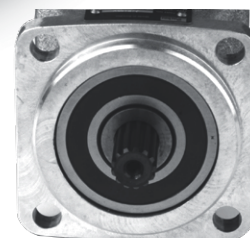

T1 Pump

The T1 fixed displacement pump is a further development of series T1, which was specifically designed to meet the requirements of light duty truck applications with short, non-frequent operating cycles such as tippers, and small loaders.

The design is very similar to that of the F1 series pumps but is even more compact. It utilises our well proven 45° concepts with spherical pistons and laminated piston rings, offering high volumetric and mechanical efficiencies and, thanks also to the small number of parts, unprecedented reliability.

- Shaft speed to 2300 rpm
- Operating pressure up to 350 bar
- High overall efficiency
- Low weight
- Small installation dimensions
- Robust construction

The T1, with shaft and mounting flange configuration conforming to the European standard, can be installed on most European truck gearboxes. Suitable power-take-offs are also available from Parker Hannifin.



Typical T1 applications

- Front end tippers
- Under body tippers
- Hydraulic system infrequently used and with short cycle times.

See page 37



Find more information on the T1 product page.

F1 Motor ISO

Features:

- Laminated piston rings – low leakage
- Positive synchronisation with timing gear
- Operating pressure up to 250 bar
- Tolerates low temperatures and high temperature shocks
- Shaft end and mounting flange meet the ISO standard for all sizes
- Tolerates high acceleration

See page 41



Find more information on the
F1 motor product page.



F2 Twin-flow Pump

Series F2 is a further development of the twin-flow version of series F1, the very first bent-axis truck pump on the market to feature two entirely independent flows.

With a suitable build-up of the hydraulic system, the main advantage with a twin-flow pump is that three different flows can be provided at the same engine speed.

The twin-flow pump makes it possible to further optimise the hydraulic system and offers:

- Less energy consumption
- Reduced risk of system overheating
- Lower weight
- Easier installation
- Standardised system solutions

The twin-flow pump makes it possible to operate two work functions that are independent of each other which leads to higher speed and an increased operating precision.

Another requirement can be a large and a small flow, or two equal flows. All of these alternatives are possible with the twin-flow pump.

The pump can be utilised to provide one flow at high system pressure, and, as soon as the pressure has decreased sufficiently, add the flow from the other circuit.

This eliminates the risk of exceeding the PTO power rating and, at the same time, provide an optimal driving function.

See page 43



Find more information on the F2 product page.

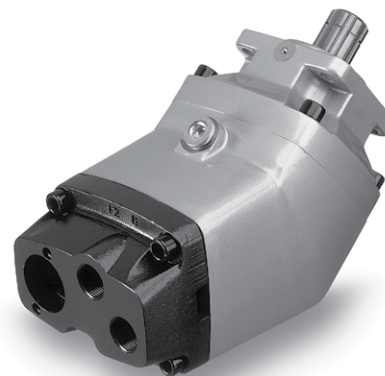

Typical twin-flow applications

- Large truck loaders
- Forestry cranes
- Hook loaders/lift dumpers
- Tipper/crane combinations
- Refuse collecting vehicles

The pump shaft end/mounting flange meets the ISO standard and suits PTO direct mounting.

F3 Pump ISO

Disengageable Fixed Displacement – Axial Piston Pump for engine PTO

The new, disengageable F3 series is a global innovation in mobile hydraulics. By engaging and disengaging the pump from the diesel engine on the fly, you can save substantial amounts of fuel. But you also reduce wear and tear on the pump and minimize the risk of costly downtime and standstills – while also reducing the noise level. All that is required is to press a button on the dashboard, without turning off the engine!

Save on fuel!

For the average truck running 100,000 kilometres a year, savings can amount to between 200 and 300 litres (45 – 65 gallons) less diesel, with a corresponding reduction in emissions of greenhouse gases and particulates, all due to the F3 pump being completely disconnectable when not in use. This is a unique, patented characteristic now being launched by Parker Hannifin.

Enhanced reliability!

When a pump is fitted to an engine PTO, even small mishaps like a ruptured hose can result in having to be recovered and towed to a workshop, with all its downsides by way of major outlay and high downtime costs. With the new F3, you just disconnect the pump and make your way home under your own steam!

Reduce noise levels!

Compared to a conventional hydraulic pump in the unloaded position, the new F3 generates considerably lower noise levels in disconnected mode – this makes matching future noise emissions regulations easier.

Features of the F3 are:

- Disengageable and engageable
- Air operated
- High selfpriming speeds
- Operating pressures up to 400 bar
- High overall efficiency
- Low noise level
- Small installation dimensions
- Low weight

See page 46



Find more information on the F3 product page.

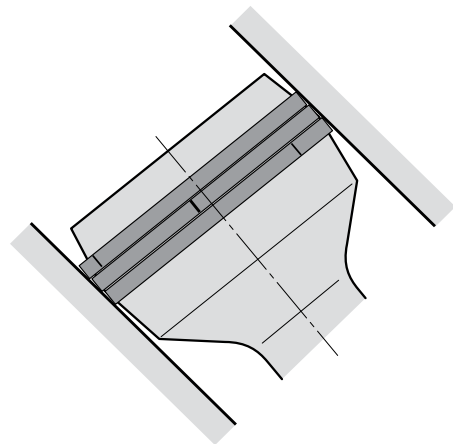

F3 piston with laminated piston ring.

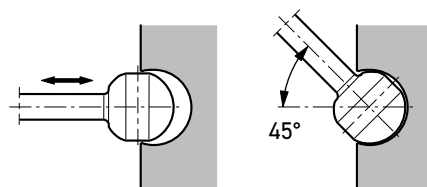

F3 piston-to-shaft locking.

... thanks to:

- Integrated coupling enables engaging and disengaging the pump
- 45° bent-axis angle
- Optimal inlet port geometry in the end cap
- Spherical pistons – high speeds
- Laminated piston rings – low leakage
- Positive synchronisation with timing gear
- Installation above the reservoir level possible
- Tolerates low temperatures and high temperature shocks
- Shaft end and mounting flange meet the ISO standard for all sizes

F4 twin flow truck pump declutchable

The new, disengageable F4 series is a global innovation in mobile hydraulics. By engaging and disengaging the pump from the diesel engine on the fly, you can save substantial amounts of fuel. But you also reduce wear and tear on the pump and minimize the risk of costly downtime and standstills – while also reducing the noise level. All that is required is to press a button on the dashboard, without turning off the engine!

Save on fuel!

For the average truck running 100,000 kilometres a year, savings can amount to between 200 and 300 litres (45 – 65 gallons) less diesel, with a corresponding reduction in emissions of greenhouse gases and particulates, all due to the F4 pump being completely disengageable when not in use. This is a unique, patented characteristic now being launched by Parker Hannifin.

Enhanced reliability!

When a pump is fitted to an engine PTO, even small mishaps like a ruptured hose can result in having to be recovered and towed to a workshop, with all its downsides by way of major outlay and high downtime costs.

With the new F4, you just disengage the pump and make your way home under your own steam!

Reduce noise levels!

Compared to a conventional hydraulic pump in the unloaded position, the new F4 generates considerably lower noise levels in disengaged mode – this makes matching future noise emissions regulations easier.

Features of the F4 are:

- Disengageable and engageable
- Air operated
- High selfpriming speeds
- Operating pressures up to 400 bar
- High overall efficiency
- Low noise level
- Small installation dimensions
- Low weight

See page 51



Find more information
on the F4 product page.

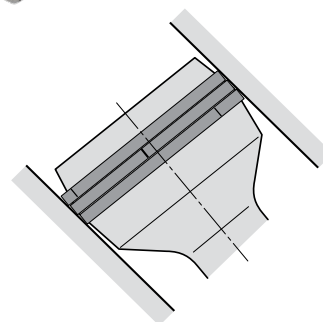

F4 piston with laminated piston ring.

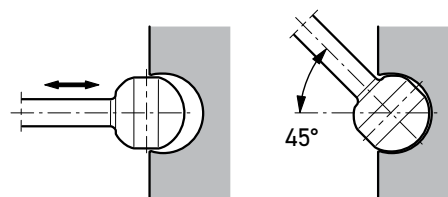

F4 piston-to-shaft locking.

... thanks to:

- Integrated coupling enables engaging and disengaging the pump
- 45° bent-axis angle
- Optimal inlet port geometry in the end cap
- Spherical pistons - high speeds
- Laminated piston rings - low leakage
- Positive synchronisation with timing gear
- Installation above the reservoir level possible
- Tolerates low temperatures and high temperature shocks
- Shaft end and mounting flange meet the ISO standard for all sizes

Typical twin-flow applications

- Large truck loaders
- Forestry cranes
- Hook loaders/lift dumpers
- Tipper/crane combinations
- Refuse collecting vehicles

VP1 Pump

The VP1 is a variable displacement pump for truck applications. It can be close-coupled to a gearbox PTO (power take-off) or to a coupling independent PTO (e.g. an engine PTO) which meets ISO standard 7653-1985.

An application that makes full use of all the features of the VP1 is truck cranes with a load sensing system. The complex systems of refuse collection vehicles and sewage trucks as well as various combinations of tippers, cranes, snow ploughs, and salt/sand spreaders can also be greatly simplified and optimised with the VP1 pump.

The VP1 provides the hydraulic system with the correct amount of fluid at precisely the right moment, effectively reducing energy consumption and heat generation. This means a smoother and quieter hydraulic system with much reduced impact on the environment.

The VP1 is highly efficient and extremely light. It is reliable, economical and easy to install.

The 6 frame sizes, VP1-045, -060 -075, -095, -110 and -130 have small installation dimensions.

Design

Large angle – compact design

The pump design permits a large angle, 20°, between piston and slipper shoe/swashplate, providing compactness and small outer dimensions.

Tandem coupling

The through-shaft on VP1-045/-060/-075 permits tandem coupling of an additional pump, such as a series F1 fixed displacement pump, as standard.

On VP1-095/-110/-130 it is available as an option in the ordering code.

Long life

The VP1 is designed for trucks with hydraulic load sensing systems. It is sturdy, yet simple, with few moving parts. The result is a reliable pump with long service life.

See page 57



Find more information on the VP1 product page.



The VP1 is suitable for all load sensing systems, regardless of make.

Features

- Variable displacement
- Low noise level
- High power-to-weight ratio
- Compact and light
- Highly efficient
- Sturdy design
- Withstands low temperatures
- Tandem mounting option
- Variable displacement
- Different regulators (Hydraulic LS & electric EPC1 & EPC2)

Accessories

Adaptor kits and accessories
for F1, T1, F2, F3, F4
and VP1 pumps

Fittings

Suction fittings and fitting kits

See page 71

Bypass valve

BPV-F1/-T1, BPV-F1-25 and -81, BPV-F2,

See page 74 ff

Unloading valve

BPV-VP1, BPV-L.

See page 81

Accessories

Universal PTO air valve kits, PTO adapter kits for engines,
pump couplings and mounting brackets, and splitter boxes
(SB 1-1,18, 1-1,54)

See page 83

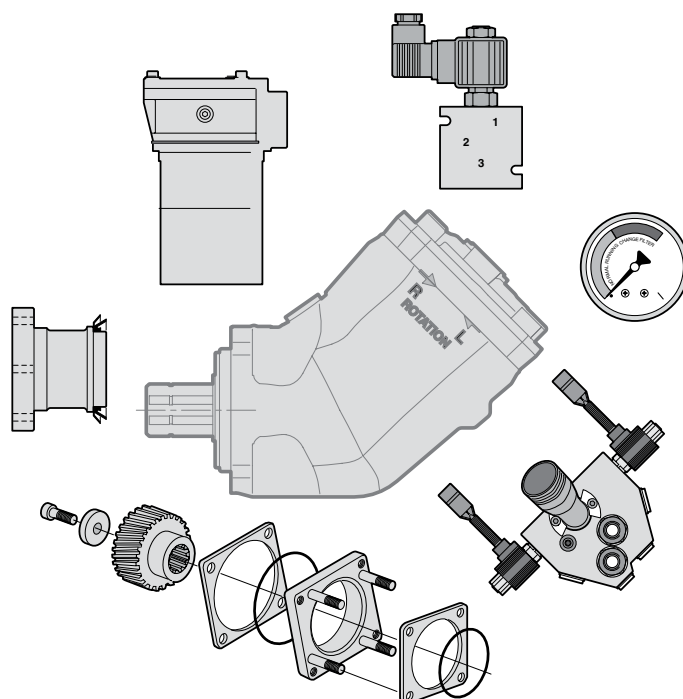

PUMP AND LINE SELECTION

Installation guide lines for GPA, GP1, F1, T1, F2, F3, F4 and VP1 pumps

Contents	Page
Pump selection	
F1, T1, F2, F3 and F4	15
Line selection	
All pumps	16
Nomogram	17

Pump selection

F1, T1, F2, F3 and F4

The following table shows examples of pump flow at selected PTO gear ratios and engine rpm's.

PTO gear ratio	Engine speed [rpm]	Pump flow [l/min]											
		F1-25	F1-41	F1-51	F1-61	F1-81 T1-81 F3-81	F1-101 F3-101	T1-121	F2-42/42 Port A/B	F4-53/53 F2-53/53 Port A/B	F2-55/28 Port A/B	F4-70/35 F2-70/35 Port A/B	F2-70/70 Port A/B
1:0.8	800	16	26	33	38	52	66	76	26/27	35/33	35/18	44/23	44/44
	900	18	29	37	43	59	74	85	31/30	40/37	40/20	50/26	49/49
	1000	20	33	41	48	65	82	95	35/33	44/42	44/22	55/29	54/54
	1100	23	36	45	52	72	91	104	38/36	48/46	48/25	61/32	60/60
	1200	25	39	49	57	78	99	114	42/39	53/50	53/27	66/35	65/65
1:1.0	800	20	33	41	48	65	82	95	34/33	44/42	44/22	55/29	54/54
	900	23	37	46	54	73	93	107	39/37	50/47	50/25	62/32	61/61
	1000	26	41	51	60	82	103	119	43/41	54/52	55/28	69/36	68/68
	1100	28	45	56	65	90	113	130	47/45	60/57	31/31	76/40	75/75
	1200	31	49	61	71	98	123	142	52/49	66/63	66/37	83/43	82/82
1:1.25	800	26	41	51	60	82	103	119	43/41	55/52	55/28	69/36	68/68
	900	29	46	57	67	92	116	133	48/46	62/59	62/32	78/41	77/77
	1000	32	51	64	74	102	129	148	54/51	69/65	69/35	86/45	85/85
	1100	35	56	70	82	111	141	163	59/56	76/72	76/39	95/50	94/94
	1200	38	61	77	89	122	154	178	65/62	83/78	83/42	104/54	102/102
1:1.5	800	31	49	61	71	98	123	142	52/49	66/63	66/37	83/43	82/82
	900	35	55	69	80	110	139	160	58/55	74/70	74/38	93/49	92/92
	1000	38	61	77	90	122	154	178	65/62	83/78	83/42	103/54	102/102
	1100	42	67	84	98	135	170	196	71/68	91/86	91/46	114/60	112/112
	1200	46	74	92	107	147	185	213	77/74	99/94	99/50	124/65	-/122

NOTE:

- Make sure max torque and bending moment (due to the weight of the pump) of the utilised PTO are not exceeded. (The approx. center of gravity of the various pump sizes are shown in the installation drawings).
- Make sure max allowed output torque from the PTO is not exceeded.
- Contact Parker Hannifin if the inlet (suction) pressure is believed to be less than 1.0 bar (absolute); insufficient inlet pressure can cause noise and pump damage because of cavitation.

Flow and torque formulas

(no regard to efficiency)

$$\text{Flow: } Q = \frac{D \times n}{1000} \text{ [l/min]}$$

where: D is pump displacement [cm³/rev]
n is shaft speed [rpm]

$$\text{Torque: } M = \frac{D \times p}{63} \text{ [Nm]}$$

where: D is pump displacement [cm³/rev]
p is utilised pressure [bar]

A suitable pump size for a truck application can be selected as follows:

Operating conditions

As an example, a cargo crane specifies:

- Flow: 60 – 80 l/min
- Pressure: 230 bar
- Diesel engine speed ≈ 800 rpm

Determine pump speed

As example a PTO with a Gear Ratio of 1:1.54.

The pump speed will be:

• $800 \times 1.54 \approx 1200$ rpm

Select a suitable pump size

Use diagram 1 and select a pump that will provide 60 – 80 l/min at 1200 rpm.

Follow line 'a' (1200 rpm) until it crosses line 'b' (70 l/min).

- F1-61 is a suitable choice

Required input torque

Make sure the PTO and the gear-box tolerates the pump torque. Use diagram 2 to obtain the required pump torque.

Follow a line from 'c' (230 bar) until it crosses the F1-61 line (the selected pump).

- Read 220 Nm (at 'd')

NOTE: A rule-of-thumb is to select the highest PTO ratio and the smallest pump size that meets the crane specification without exceeding the pump speed, pressure, and power limitations.

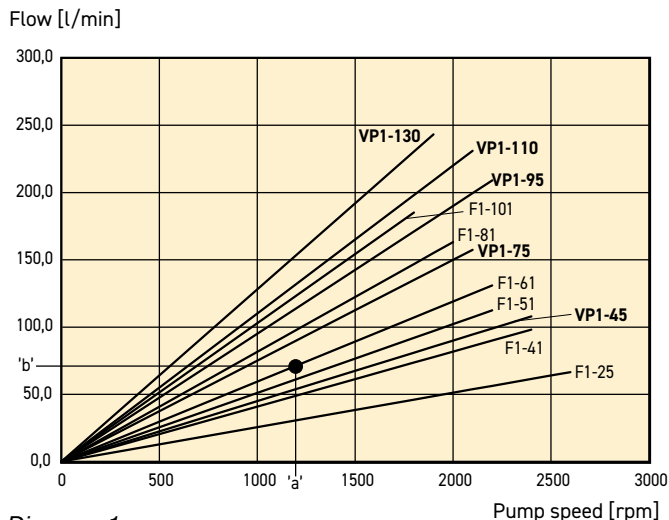

Diagram 1.

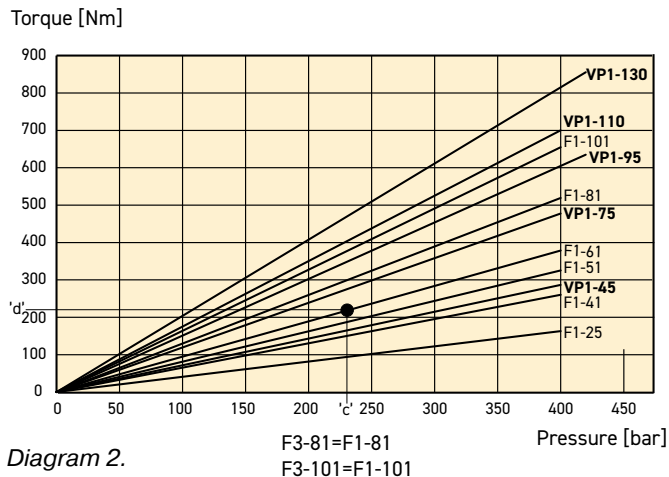

Diagram 2.

Line selection

all pumps

Line type	Flow velocity [m/s]
Inlet (suction)	max 1.0
Outlet (pressure)	max 5.0

Flow rate [l/min]	Flow velocity [m/s] at selected line sizes [mm/inches]						
	19 / 3/4"	25 / 1"	32 / 1 1/4"	38 / 1 1/2"	51 / 2"	64 / 2 1/2"	75 / 3"
25	1.5	0.8	0.5	0.4	0.2	0.1	0.1
50	2.9	1.7	1.0	0.7	0.4	0.3	0.2
75	4.4	2.5	1.6	1.1	0.6	0.4	0.3
100	5.9	3.4	2.1	1.5	0.8	0.5	0.4
150	8.8	5.1	3.1	2.2	1.3	0.8	0.5
200	-	-	4.1	2.9	1.6	1.1	0.7
250	-	-	5.3	3.7	2.1	1.3	0.9

Inlet (suction line)

Table 1. Outlet (pressure line)

In order to obtain sufficient inlet (suction) pressure to the pump, low noise level and low heat generation, flow speeds shown in table 2, right, should not be exceeded.

From table 1 (page 15), select the smallest line dimension that meets the flow speed recommendation; example:

- At 100 l/min, a 50 mm suction line and a 25 mm pressure line is needed.

NOTE: Long inlet (suction) lines, low inlet pressure (caused by e.g. a reservoir positioned below the pump) and/or low temperatures may require larger line dimensions.

Alternatively, the pump speed will have to be lowered to avoid pump cavitation (which may cause noise, deteriorating performance and pump damage).

Line type	Flow velocity [m/s]
Inlet (suction)	max 1.0
Outlet (pressure)	max 5.0

Table 2.

Nomogram

Flow – Line dimension – Flow velocity

Example 1
Pressure line
Q = 65 l/min
d = 3/4"
v = 3.8 m/s

Example 2
Suction line
Q = 50 l/min
v = 0.8 m/s
d = 1 1/2"

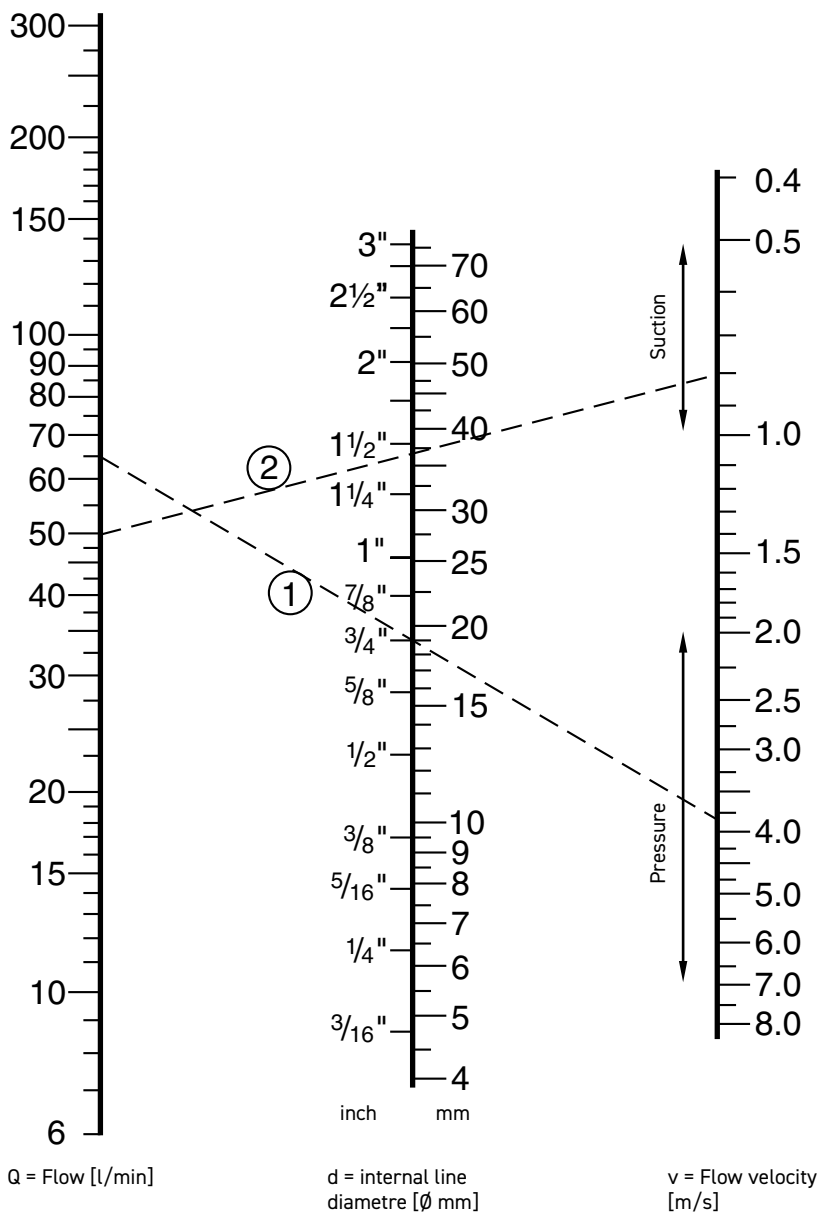

Table 3.

CONTENTS

GPA and GP1 Pumps



Contents	Page
Pump and Line selection	14
Specifications	19
Installation Dimensions	20 - 22
Ordering Information/Ordering code	23
Suction fittings	71
Installation and start up	87

TECHNICAL INFORMATION

GPA and GP1

Specifications

Series GPA (aluminum body; 4-bolt)

Frame size GPA*	008	011	014	016	019
Displacement [cm ³ /rev]	8	11	14	16	19
Max pressure [bar]	250				
Speed [rpm] (at max pressure) min max	500 2000	500 2000	500 2000	500 1750	500 1500
Weight [kg]	4.9	5.05	5.2	5.3	5.4

* Multi-section GPA pumps available on request.

Series GP1 (cast iron body; 4-bolt)

Frame size GP1*	023	029	041	046	060	080
Displacement [cm ³ /rev]	23	29	41	46	60	80
Max pressure [bar]	250	250	220	210	250	210
Speed [rpm] min max	500 2000	500 2000	500 2000	500 2000	500 1800	500 1600
Weight [kg]	7.3	7.7	8.5	8.8	13.5	14.0

* Multi-section with GPA pumps available on request.

INSTALLATION DIMENSIONS

GPA-008/-011/-014/-016/-019 4-bolt

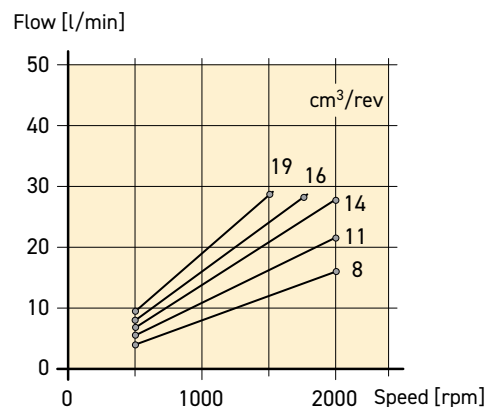
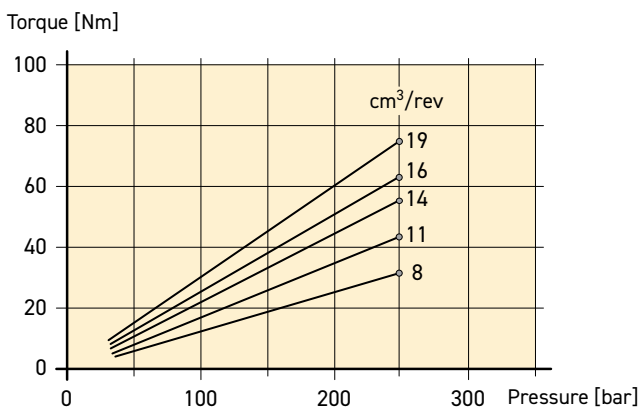
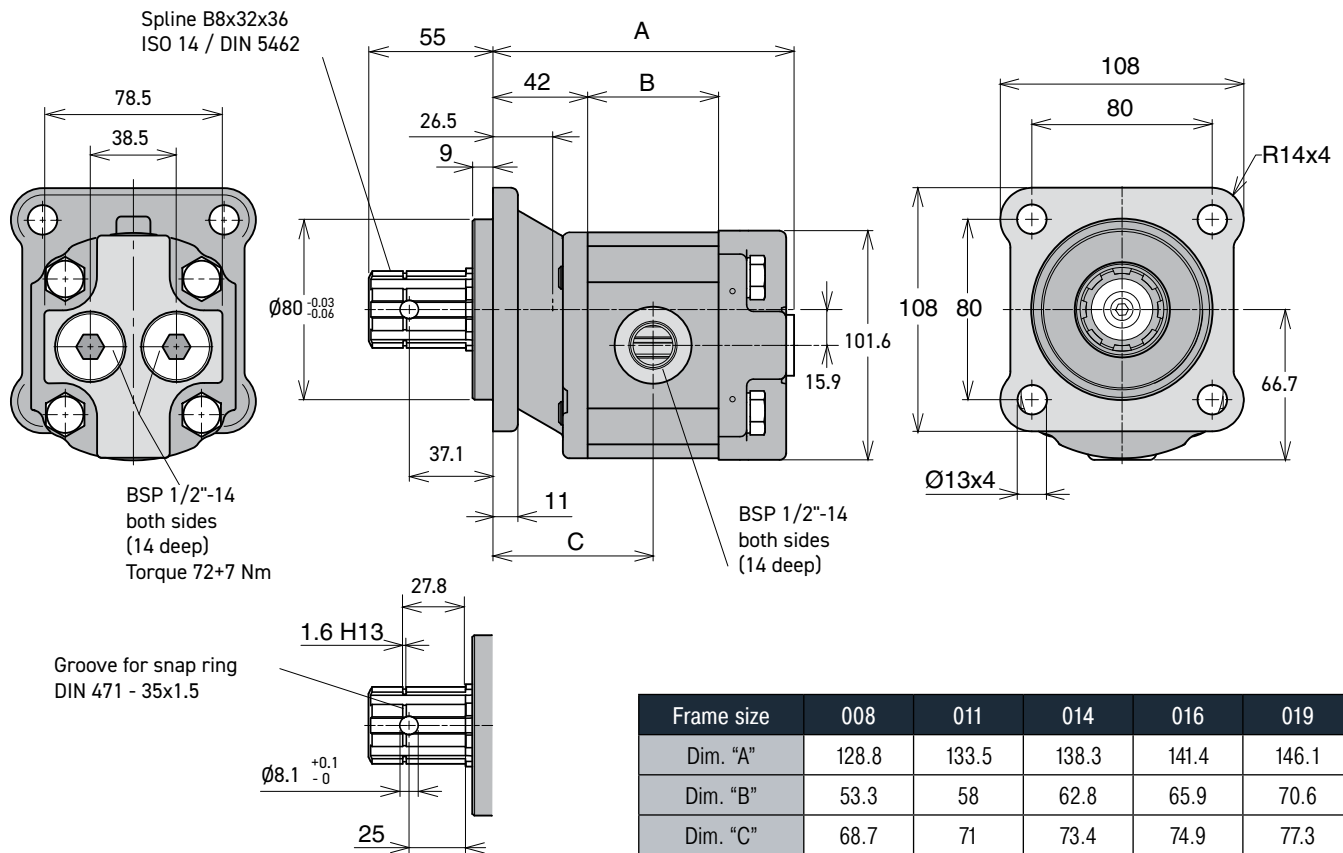

Diagrams reflect theoretical values

Direction of rotation: Bi-directional
 Input pressure: 0.8 to 2.0 bar (absolute)
 Fluid temperature: -15 °C to +80 °C
 Range of operating viscosity: 8 to 1000 mm²/s (cSt)

GP1-023/-029/-041/-046 4-bolt

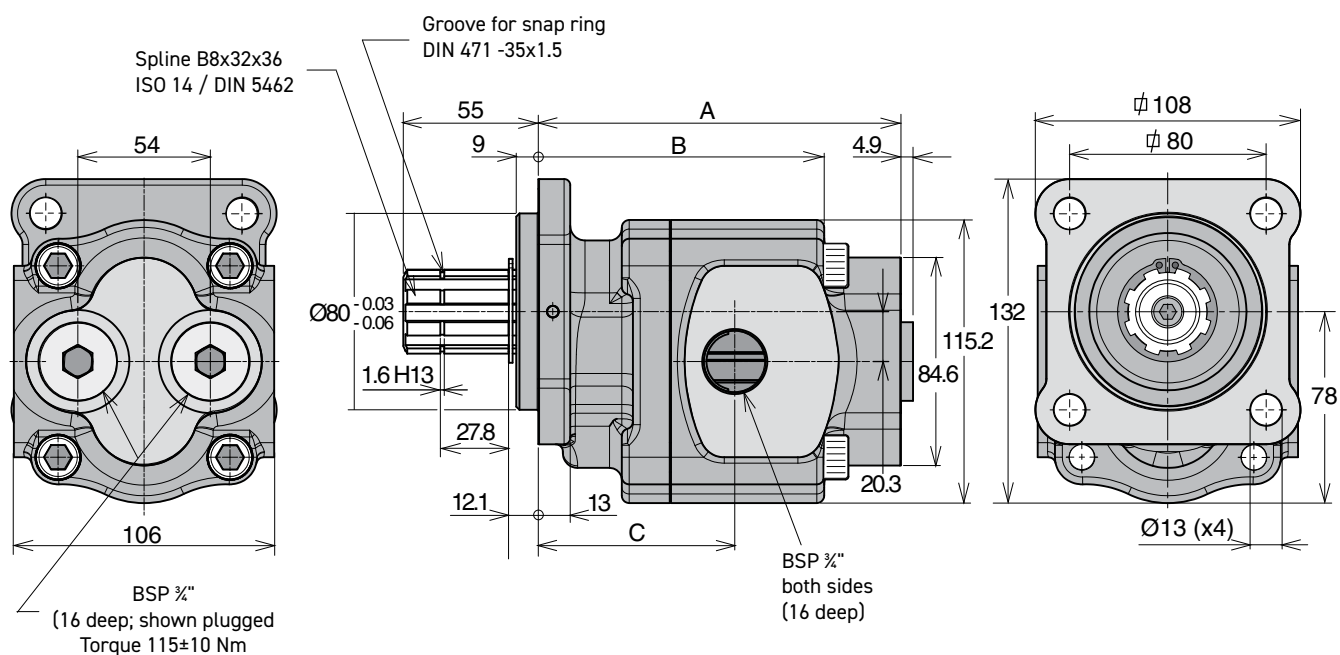

Frame size	023	029	041	046
Dim. "A"	128.5	134.3	147.7	153.2
Dim. "B"	97.3	103.3	116.4	121.9
Dim. "C"	77.1	76.0	80.0	84.8

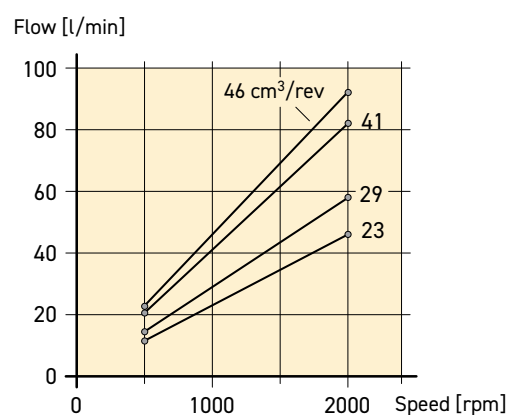
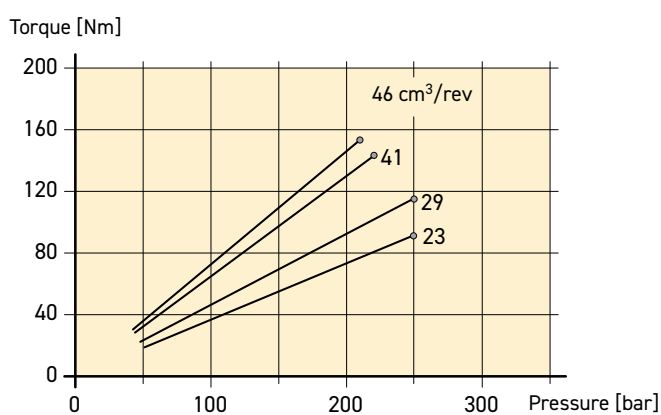

Diagrams reflect theoretical values

Direction of rotation: Bi-directional
 Input pressure: 0.8 to 2.0 bar (absolute)
 Fluid temperature: -15 °C to +80 °C
 Range of operating viscosity: 8 to 1000 mm²/s (cSt)

GP1-060/-080 4-bolt

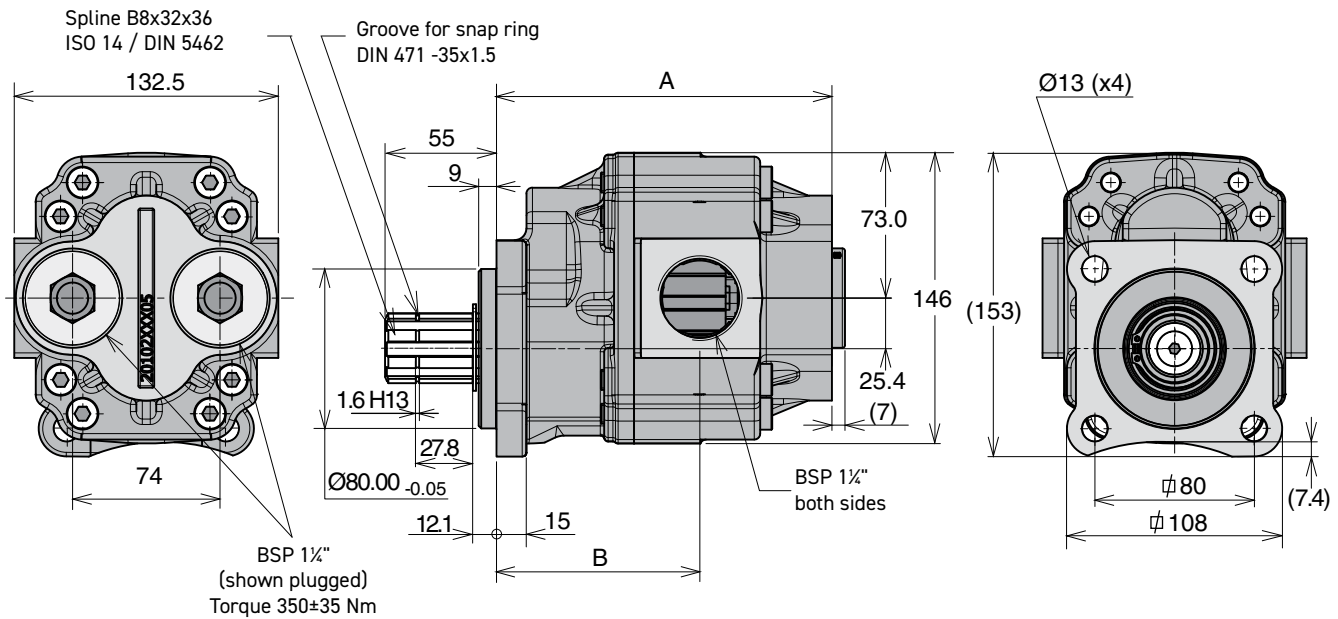

Frame size	060	080
Dim. "A"	168.3	186.5
Dim. "B"	102	108

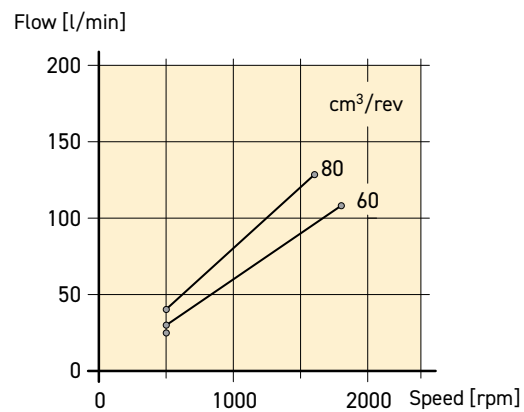
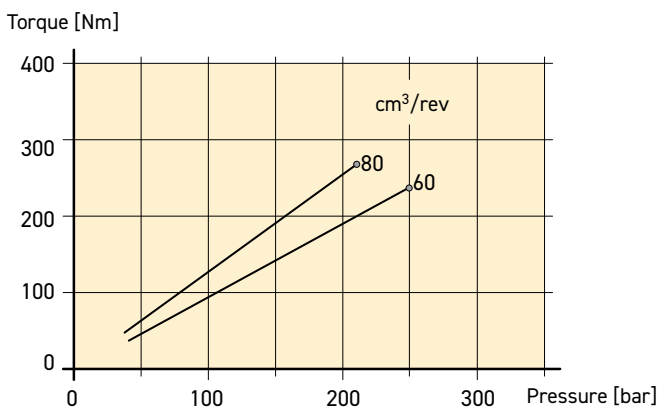

Diagrams reflect theoretical values

Direction of rotation: Bi-directional
 Input pressure: 0.8 to 2.0 bar (absolute)
 Fluid temperature: -15 °C to +80 °C
 Range of operating viscosity: 8 to 1000 mm²/s (cSt)

ORDERING INFORMATION

Ordering code

Example:

GPA- 008 - 4

A Aluminium body

1 Cast iron body

Frame size

A = 008, 011, 014, 016 or 019

1 = 023, 029, 041, 046, 060 or 080

4 4 bolt flange

NOTE: The pump does not include a suction fitting; it must be ordered separately. See page 72 ff.

Standard versions

Aluminium 4 bolt

Designation	Ordering no.
GPA-008-4	334 9113 940
GPA-011-4	334 9113 941
GPA-014-4	334 9113 942
GPA-016-4	334 9113 943
GPA-019-4	334 9113 944

Cast iron 4 bolt

Designation	Ordering no.
GP1-023-4	722 9113 005
GP1-029-4	722 9113 006
GP1-041-4	722 9113 007
GP1-046-4	722 9113 008
GP1-060-4	704 9113 942
GP1-080-4	704 9113 944

Sealkits for GPA and GP1

Designation	Ordering no.
Seal kit GPA 8-19 CC	391 1842 645
Seal kit GP1 23-46 CC	391 1842 636
Seal kit GP1 60-80 CC	391 1832 690

CONTENTS

F1 Pump, ISO



Contents	Page
Pump and Line selection	14
F1-25 to -101, ISO	25
Specifications and pump cross section	25
Installation Dimensions, F1-25, -41, -51 and -61	26
Ordering code and standard versions	26
Installation Dimensions F1-81 and -101	27
Port size and standard versions	27
Specifications F1e-61	28
F1e-81 Standard versions	29
F1-12 ISO with BSP port treads	30
Specifications and pump cross section	30
Installation Dimensions, F1-12 with BSP port treads.....	31
Ordering code and standard versions	31
Installation Dimensions, F1-25 to -101 with BSP port treads.....	32
Ordering code, port size and standard versions	32
Suction fittings.....	71
Installation and start up	87

TECHNICAL INFORMATION

F1-25 to -101, ISO

Specifications

Frame size F1-	25	41	51	61	81	101
Displacement [cm ³ /rev]	25.6	40.9	51.1	59.5	81.6	102.9
Max flow ¹⁾ [l/min]	78	104	125	143	180	216
Max operating pressure [bar]	400	400	400	400	400	400
Mass moment of inertia J [kgm ²]	0.00274	0.00266	0.00261	0.00257	0.00532	0.00524
Shaft speed [rpm]						
- short circuited pump (low press.)	3100	2700	2700	2700	2300	2300
- max selfpriming speed ²⁾	3050	2550	2450	2400	2200	2100
Torque ¹⁾ [Nm]	163	260	324	378	518	653
Max Input power ³⁾ [kW]	45	61	73	83	105	126
Weight [kg]	8.5	8.5	8.5	8.5	12.3	12.1

1) Theoretical values

2) Valid at an inlet pressure of 1.0 bar (abs.) when operating on mineral oil at a viscosity of 30 mm²/s (cSt).

3) Max 6 seconds in any one minute.

NOTE: For noise level information, contact Parker Hannifin

Pump cross section

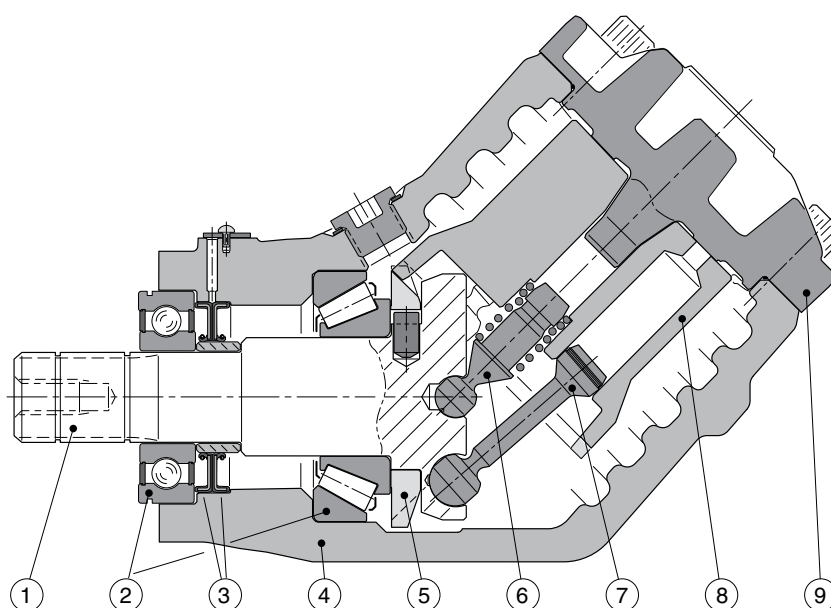

1. Input shaft

2. Bearings

3. Shaft seals

4. Housing

5. Timing gear

6. Barrel support

7. Piston with piston ring

8. Cylinder barrel

9. End cap

INSTALLATION DIMENSIONS

F1-25, -41, -51 and -61

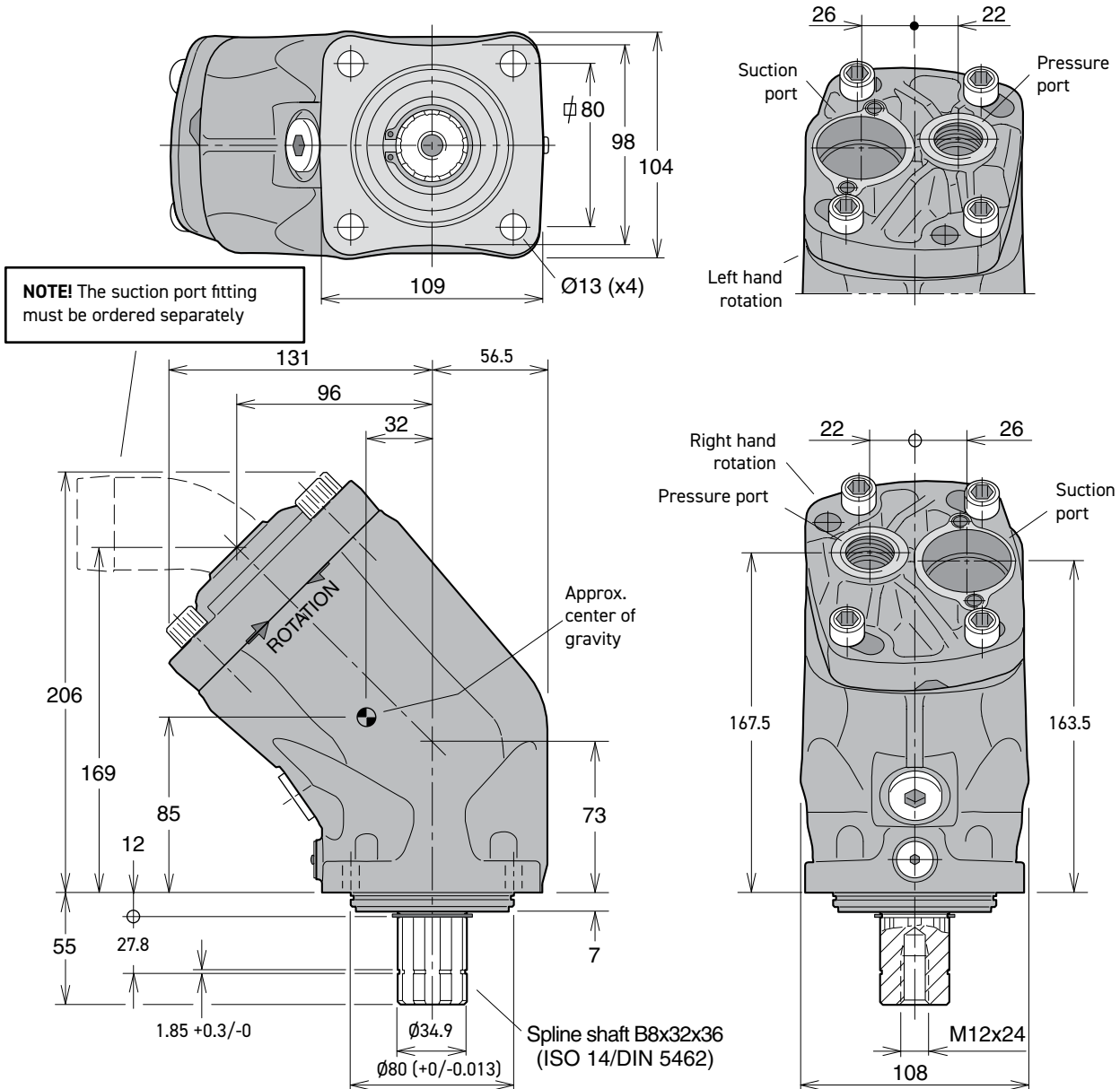

Ordering code

Example:

F1-81-R

F1 frame size

25, 41, 51, 61, 81 or 101

Shaft rotation

R Right hand

L Left hand

NOTE: The pump does not include a suction fitting; it must be ordered separately. See page 72ff.

Standard versions

Designation	Ordering no.
F1-25-R	378 1024
F1-25-L	378 1025
F1-41-R	378 1040
F1-41-L	378 1041
F1-51-R	378 1050
F1-51-L	378 1051
F1-61-R	378 1060
F1-61-L	378 1061

F1-81 and -101

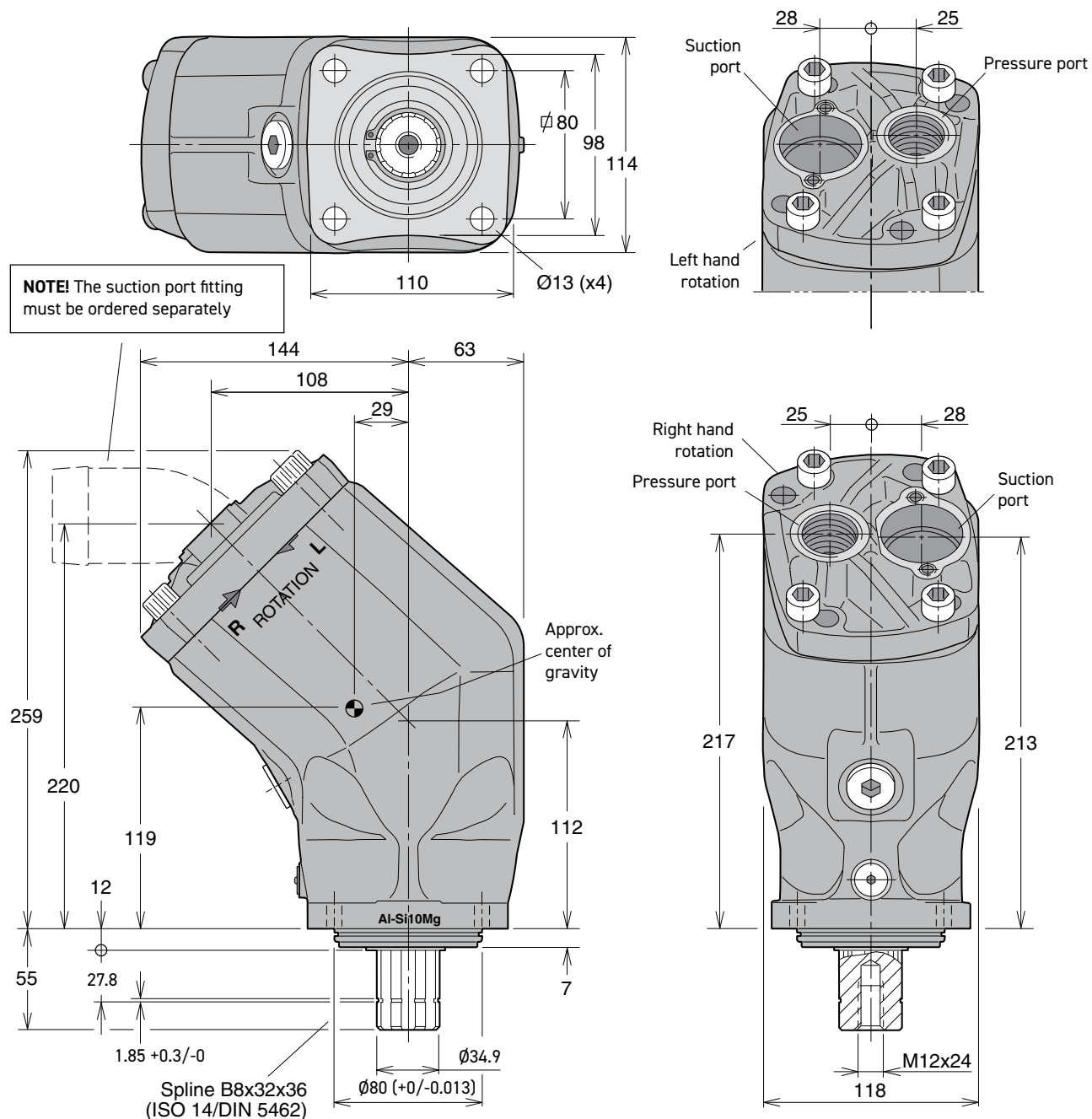

Port size

F1 frame size	Pressure port 1)
-25	3/4"
-41	3/4"
-51	3/4"
-61	3/4"
-81	1"
-101	1"

1) BSP thread (fitting not included)

Standard versions

Designation	Ordering no.
F1-81-R	378 1080
F1-81-L	378 1081
F1-101-R	378 1100
F1-101-L	378 1101

NOTE: The pump does not include a suction fitting; it must be ordered separately. See page 72ff.

F1e-61

Specifications

Frame size F1e-	61	81
Displacement [cm ³ /rev]	59.5	81.6
Max flow ¹⁾ [l/min]	143	180
Max operating pressure [bar]	400	400
Max selfpriming speed ²⁾	2400	2200
Max Input Power ³⁾ [kW]	83	105
Torque ¹⁾ [Nm]	378	518
Reduced Noise level [dBA]	<- 6	<- 6
Pressure pulsation, vs Std F1	<- 40%	<- 40%
Weight [kg]	8.5	12.5

1) Theoretical values

2) Valid at an inlet pressure of 1.0 bar (abs.) when operating on mineral oil at a viscosity of 30 mm²/s (cSt).

3) Max 6 seconds in any one minute.

NOTE: For noise level information, contact Parker Hannifin

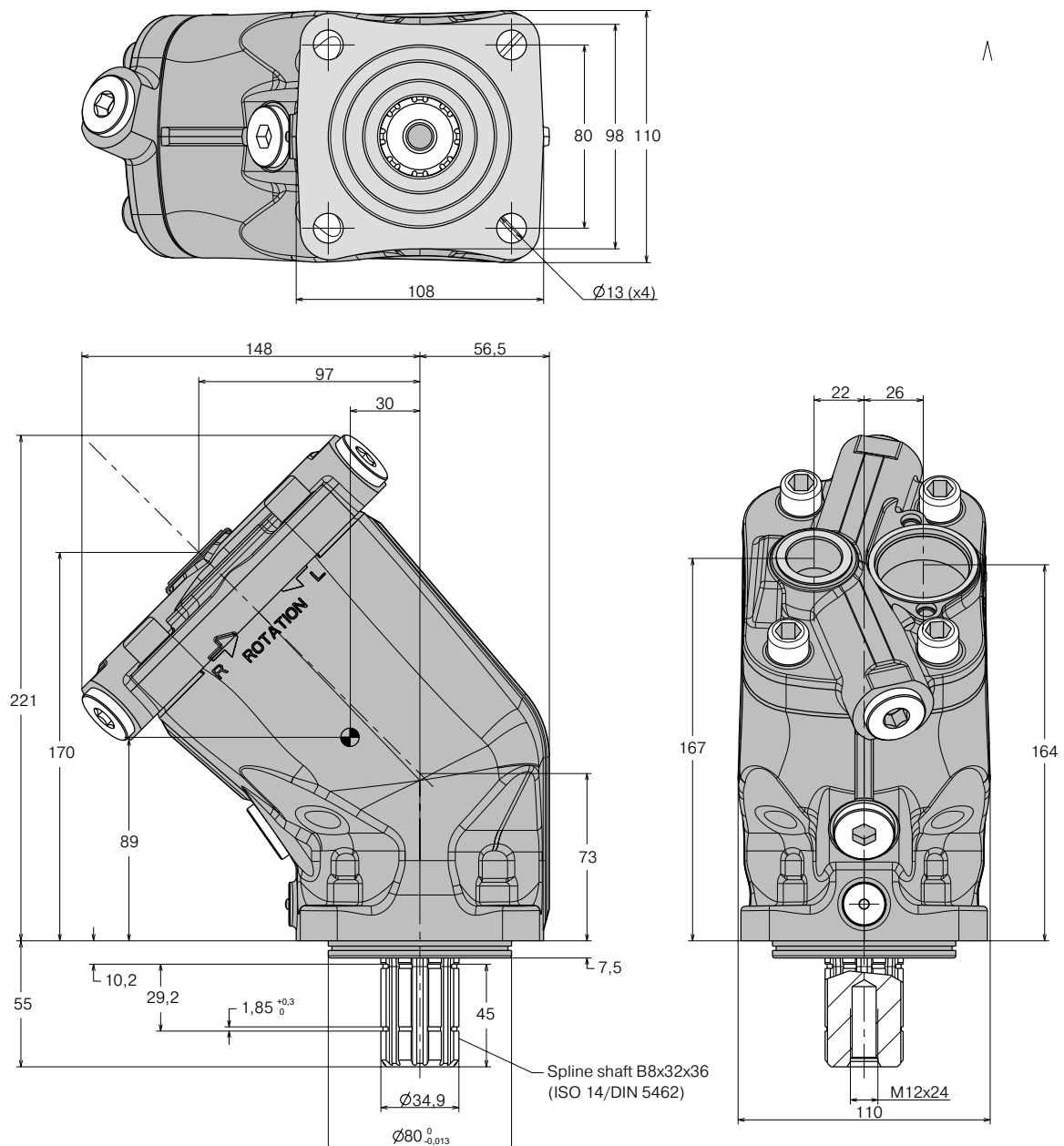

TECHNICAL INFORMATION

F1-12 ISO with BSP port treads

Specifications

Frame size F1-	12
Displacement [cm ³ /rev]	12
Max flow ¹⁾ [l/min]	28
Max operating pressure [bar]	350
Shaft speed [rpm]	
- short circuited pump (low press.)	3100
- max selfpriming speed	2300
Torque ¹⁾ [Nm]	67
Max input power [kW]	16
Weight [kg]	6.7

1) Theoretical values

NOTE: For noise level information, contact Parker Hannifin

Pump cross section

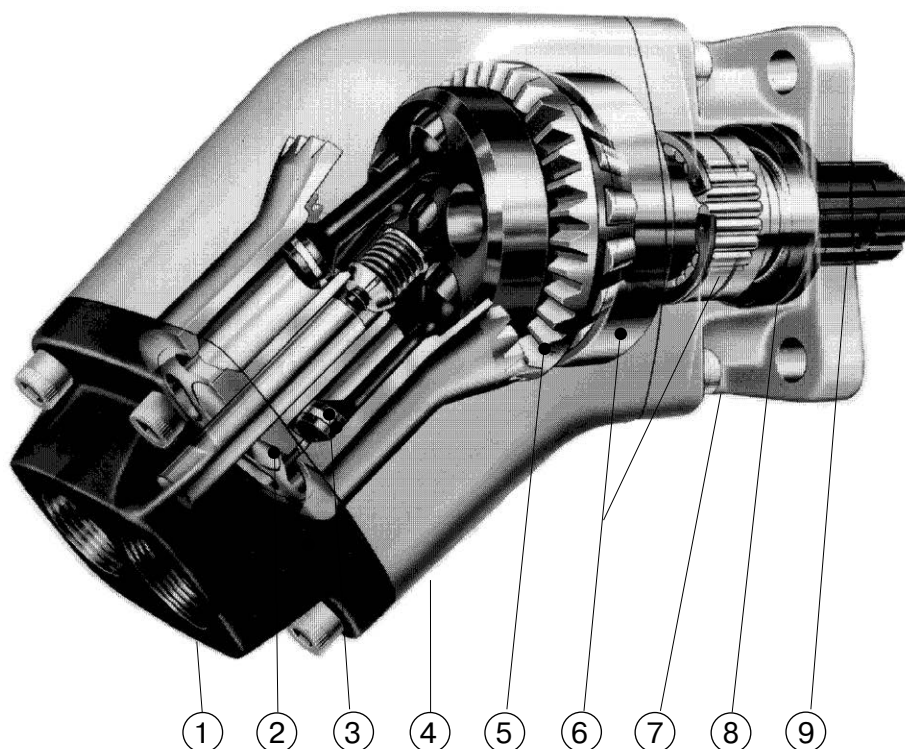

- | | | |
|----------------------------|--------------------|--------------------------------|
| 1. End cap | 4. Barrel housing | 7. Bearing housing with flange |
| 2. Cylinder barrel | 5. Timing gear | 8. Shaft seals |
| 3. Piston with piston ring | 6. Roller bearings | 9. Input shaft |

INSTALLATION DIMENSIONS

F1-12 with BSP port treads

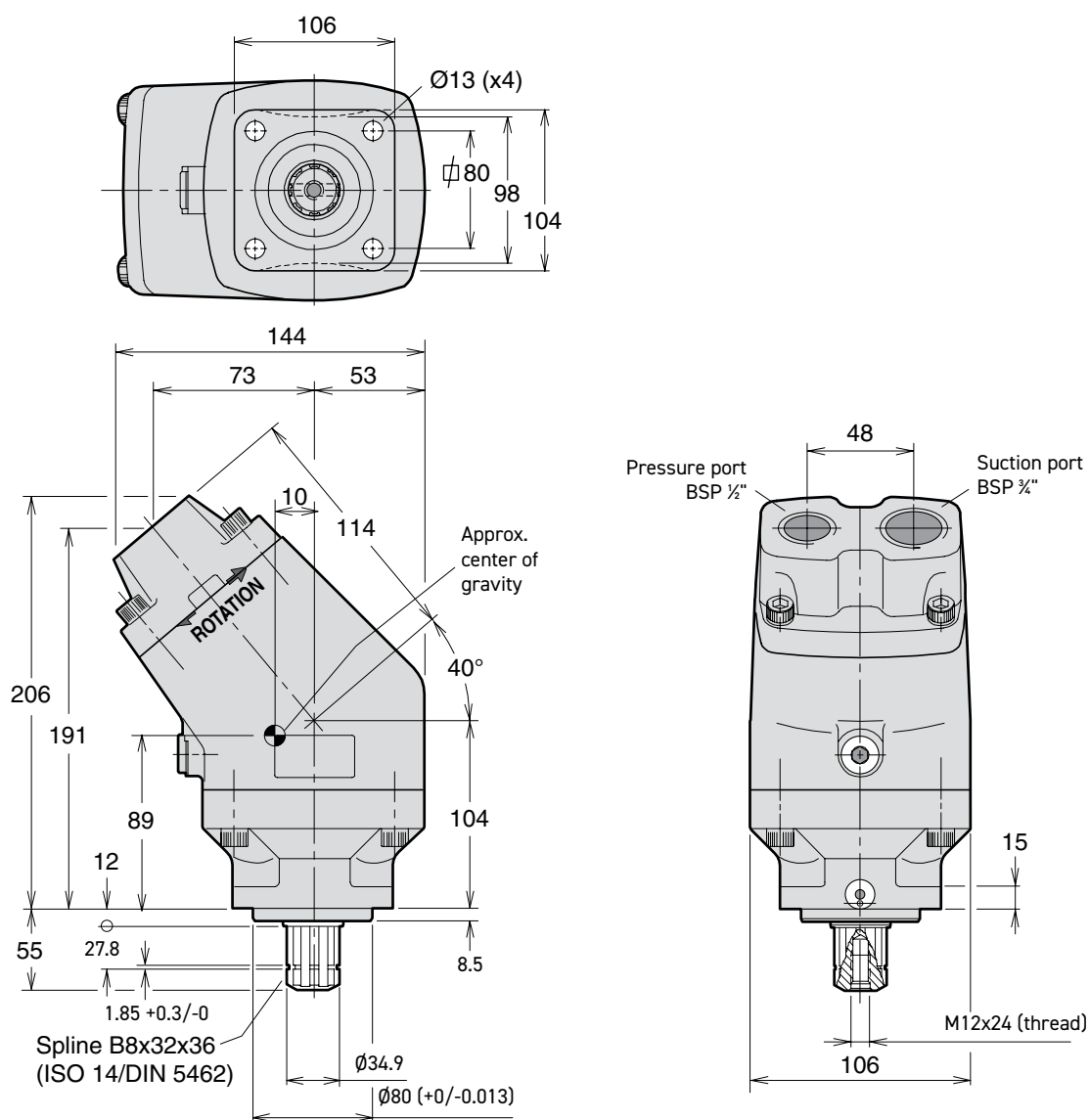

Ordering code

Example: **F1-12-R**

F1 frame size **12**

Shaft rotation

R Right hand

L Left hand

NOTE: The pump does not include a suction fitting; it must be ordered separately. See page 72ff.

Standard versions

Designation	Ordering no.
F1-12-R	378 2212
F1-12-L	378 2211

F1-25, -41, -51 and -61 with BSP port treads

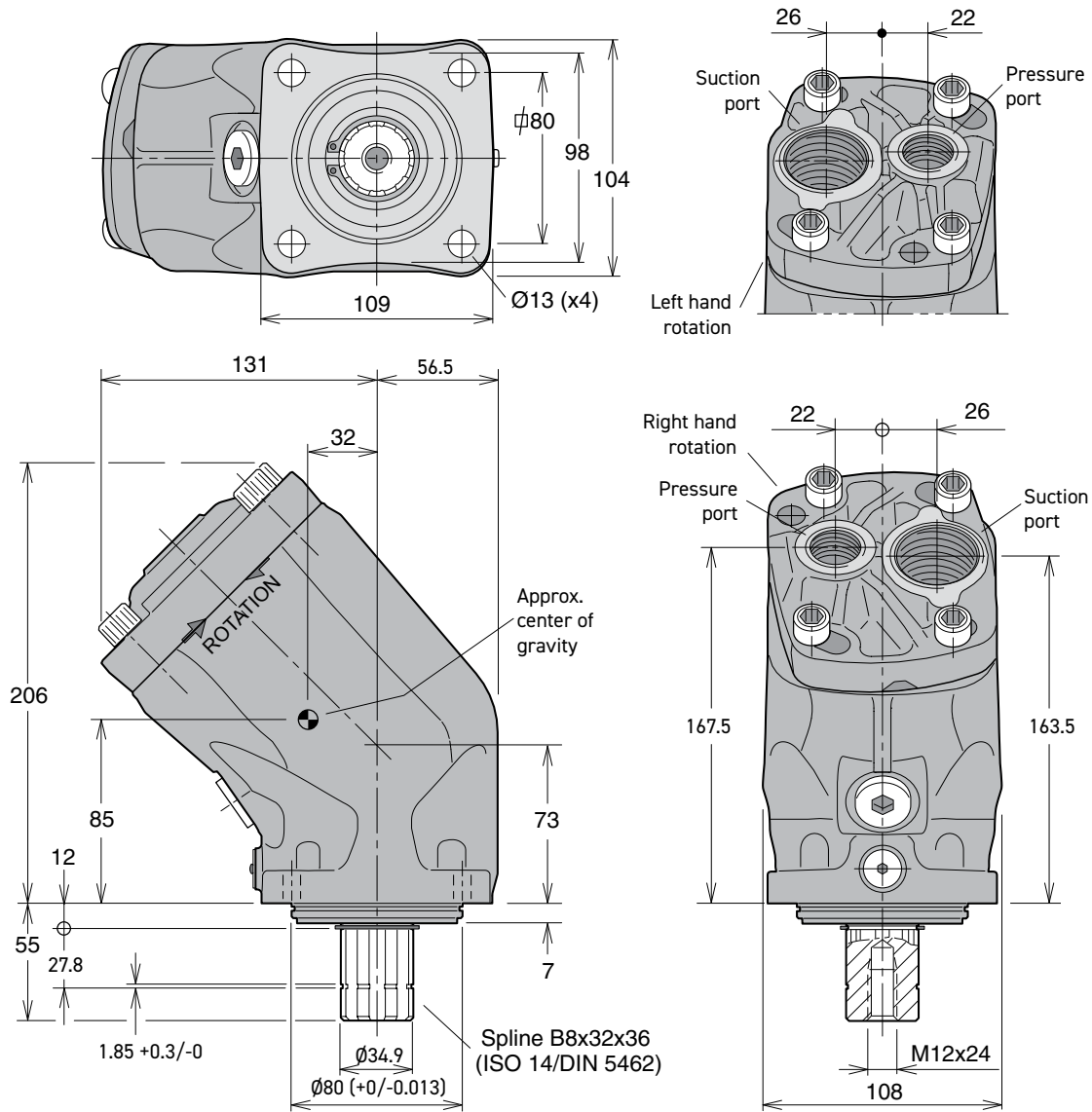

Port size (all ports are BSP)

F1 frame size	Pressure port1)	Suction port
-25	3/4"	1"
-41	3/4"	1"
-51	3/4"	1"
-61	3/4"	1"

Ordering code

Example:

F1- 61 - RB

F1 frame size **25, 41, 51, 61, 81 or 101**

Shaft rotation/port threads

RB Right hand/BSP

LB Left hand/BSP

Standard versions

Designation	Ordering no.
F1-25-RB	378 4024
F1-25-LB	378 4025
F1-41-RB	378 4040
F1-41-LB	378 4041
F1-51-RB	378 4050
F1-51-LB	378 4051
F1-61-RB	378 4060
F1-61-LB	378 4061

NOTE: The pump does not include a suction fitting; it must be ordered separately. See page 72ff.

F1-81 and -101 with BSP port treads

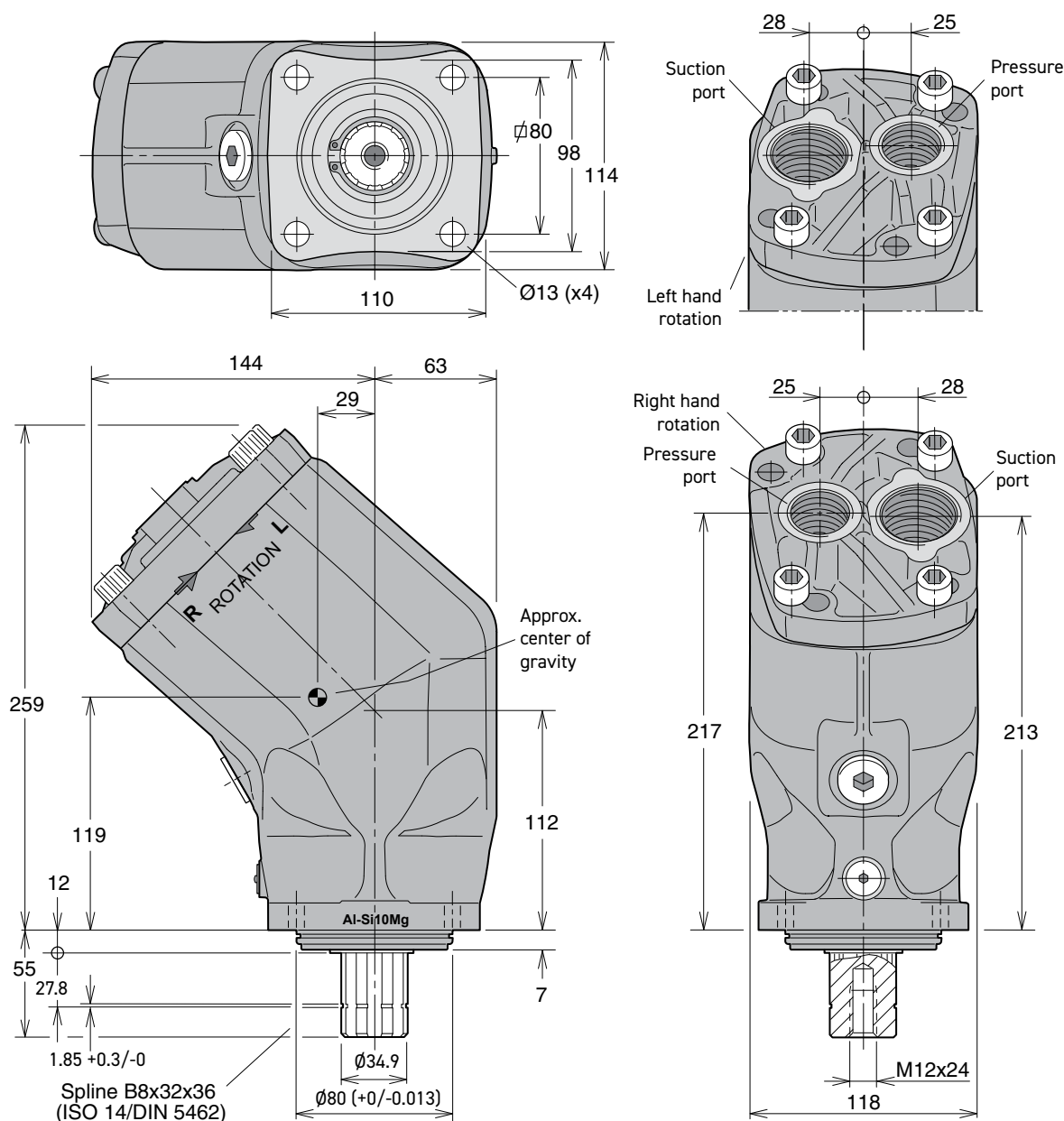

Port size (all ports are BSP)

F1 frame size	Pressure port1)	Suction port
-81	1"	1¼"
-101	1"	1¼"

Ordering code

Example:

F1-81-RB

F1 frame size

25, 41, 51, 61, 81 or 101

Shaft rotation/port threads

RB Right hand/BSP

LB Left hand/BSP

Standard versions

Designation	Ordering no.
F1-81-RB	378 4080
F1-81-LB	378 4081
F1-101-RB	378 4100
F1-101-LB	378 4101

NOTE: The pump does not include a suction fitting; it must be ordered separately. See page 72ff.

CONTENTS

F1 Pump, SAE



Contents	Page
Pump and Line selection	14
Specifications	35
Pump cross section	35
Installation Dimensions, F1-25, -41, -51 and -61 (SAE)	36
Ordering code (SAE)	36
Port size and standard versions	36
Suction fittings	71
Installation and start up	87

TECHNICAL INFORMATION

Specifications

Frame size F1-	25	41	51	61
Displacement [cm ³ /rev]	25.6	40.9	51.1	59.5
[cu in/rev]	1.56	2.50	3.12	3.63
Max flow ¹⁾ [l/min]	78	104	125	143
[gpm]	20.6	27.5	33.0	37.8
Max operating pressure [bar]	350	350	350	350
[psi]	5000	5000	5000	5000
Shaft speed [rpm]				
- short circuited pump (low press.)	3100	2700	2700	2700
- max selfpriming speed ²⁾	3050	2550	2450	2400
Torque ¹⁾				
at 350 bar [Nm]	142	227	284	331
at 5000 psi [lbf ft]	105	168	210	244
Input power				
[kW]	45	61	73	83
[hp]	60	82	98	111
Weight [kg]	8.5	8.5	8.5	8.5
[lbs]	18.7	18.7	18.7	18.7

1) Theoretical values

2) Valid at an inlet pressure of 1.0 bar/15 psi (abs.) when operating on mineral oil at a viscosity of 30 mm²/s (cSt)/150 SUS.

Pump cross section

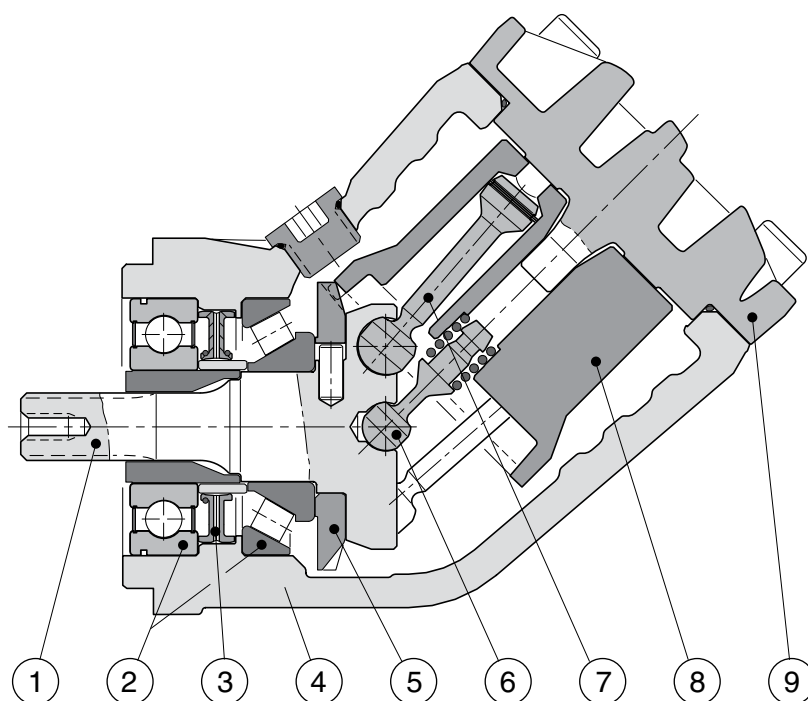

1. Input shaft
2. Bearings
3. Shaft seal
4. Housing
5. Timing gear
6. Barrel support
7. Piston with piston ring
8. Cylinder barrel
9. End cap

INSTALLATION DIMENSIONS

F1-25, -41, -51 and -61 (SAE)

Dimensions in mm [inches]

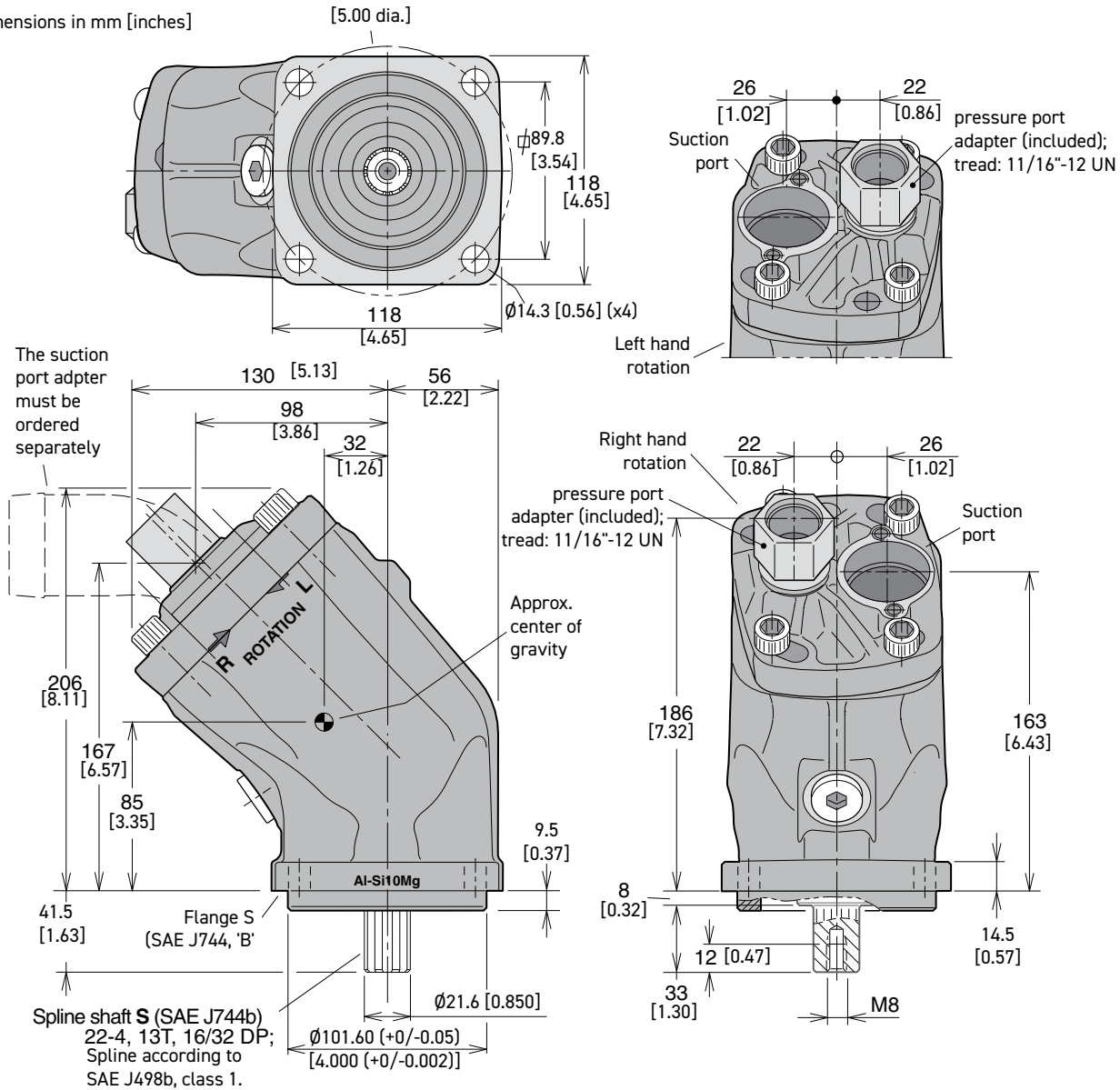

Ordering code (SAE)

Example:

F1-61-RU-SV-S

F1 frame size
25, 41, 51 or 61

Shaft rotation
R Right hand
L Left hand

Main port
U SAE O-ring, UN threads

Shaft end
S SAE spline
"B" spline

Shaft seal
V FPM

Mounting flange
S SAE "B"

Port size

F1 frame size	Pressure port ¹⁾
-25	1 1/16"-12 UN
-41	1 1/16"-12 UN
-51	1 1/16"-12 UN
-61	1 1/16"-12 UN

¹⁾ BSP-to-SAE adapter (included)

Standard SAE versions

Designation	Ordering no.
F1-25-RU	378 1424
F1-25-LU	378 1425
F1-41-RU	378 1440
F1-41-LU	378 1441
F1-51-RU	378 1450
F1-51-LU	378 1451
F1-61-RU	378 1460
F1-61-LU	378 1461

NOTE: The pump does not include a suction fitting; it must be ordered separately. See page 72ff.

CONTENTS

T1 Pump



Contents	Page
Pump and Line selection.....	14
Specifications.....	38
Pump cross section.....	38
Installation Dimensions.....	39 – 40
Ordering code	39
Standard versions	39
Port size	39
Suction fittings.....	71
Installation and start up	87

TECHNICAL INFORMATION

Specifications

Frame size T1-	81	121
Displacement [cm ³ /rev]	81.5	118.5
Max flow ¹⁾ [l/min]	163	190
Max operating pressure [bar]		
continuous	250	250
intermittent ³⁾	350	350
Shaft speed [rpm]		
- short circuited pump (low press.)	2300	2300
max speed ²⁾	2000	1600
Torque ¹⁾ [Nm]		
at 200 bar	258	376
at 350 bar	453	658
Max input power ³⁾ [kW]	95	111
Weight [kg]	8.5	12.5

1) Theoretical values

2) Valid at an inlet pressure of 1.0 bar (abs.) when operating on mineral oil at a viscosity of 30 mm²/s (cSt).

3) Max 6 seconds in any one minute.

NOTE: For noise level information, contact Parker Hannifin.

Pump cross section

(T1-121 shown)

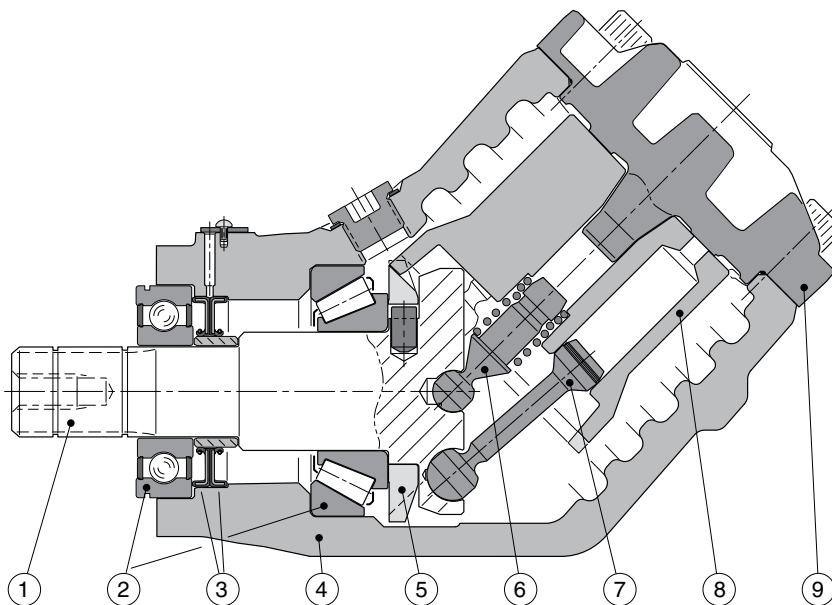

1. Input shaft

2. Bearings

3. Shaft seals

4. Housing

5. Timing gear

6. Barrel support

7. Piston with piston ring

8. Cylinder barrel

9. End cap

INSTALLATION DIMENSIONS

T1-81

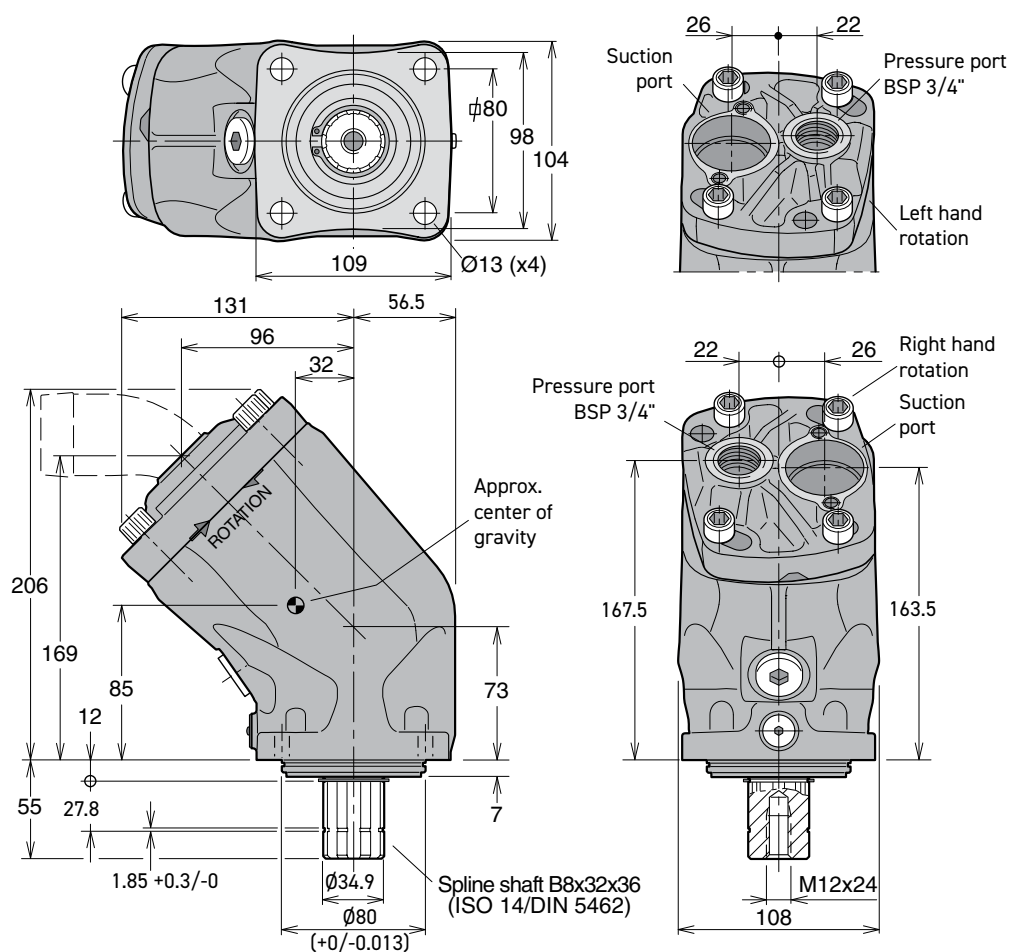

Ordering code

Example: **T1 - 81 - R**

T1 frame size **81 or 121**

Shaft rotation **RB** Right hand
LB Left hand

NOTE: The pump does not include a suction fitting; it must be ordered separately. See page 72ff.

Port size

T1 frame size	Pressure port ¹⁾
-81	3/4"
-121	1"

¹⁾ BSP thread (fitting not included).

Standard versions

Designation	Ordering no.
T1-81-R	378 2180
T1-81-L	378 2181
T1-121-R	378 2120
T1-121-L	378 2121

T1-121

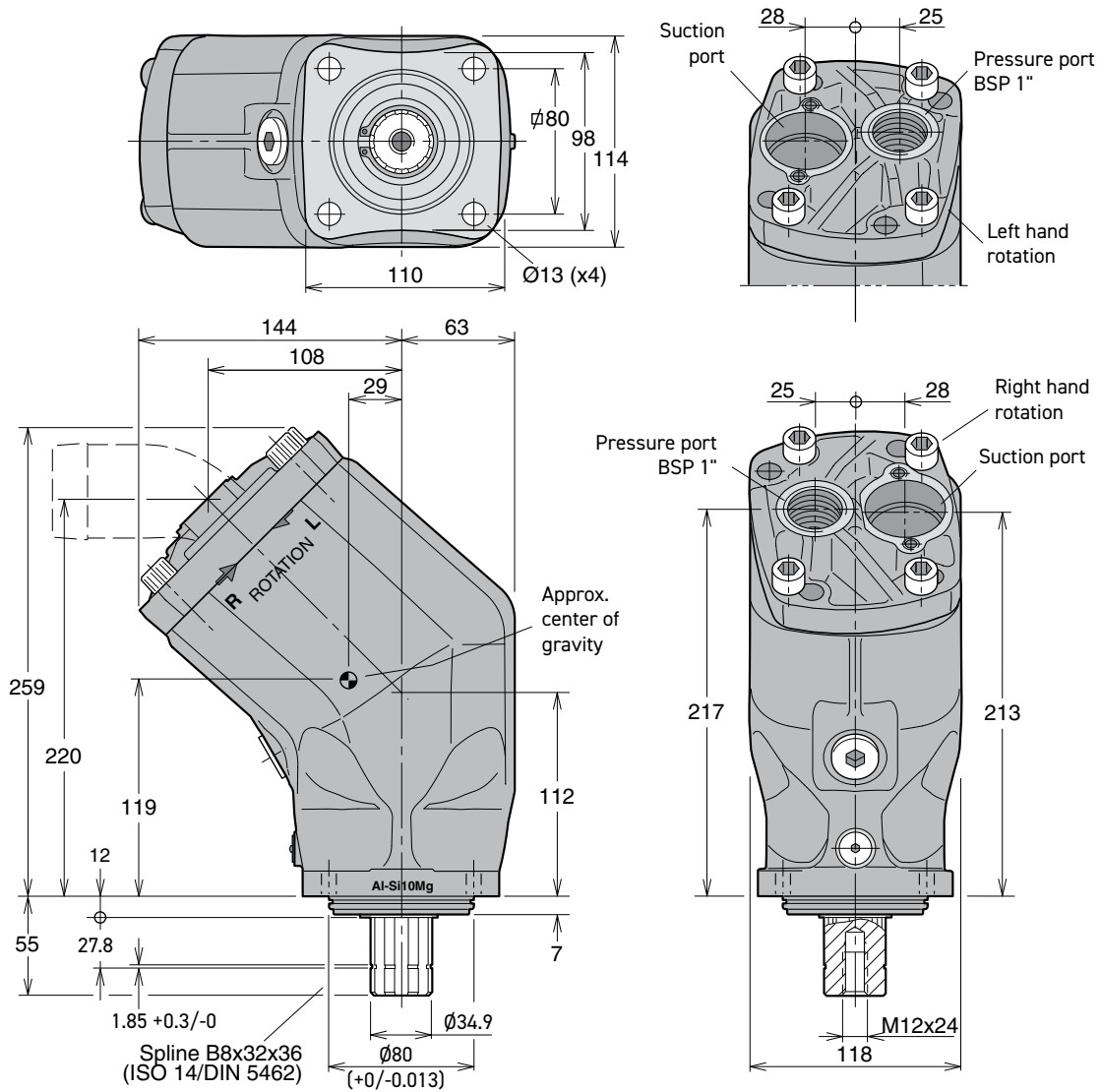

CONTENTS

F1 Motor



Contents	Page
Pump and Line selection.....	14
Specifications.....	42
Ordering code	42
Installation.....	42
Port size	42
Standard versions	42
Suction fittings.....	71
Installation and start up	87

TECHNICAL INFORMATION

Specifications

Motor frame size F1-	25-M	41-M	51-M	61-M	81-M	101-M	121-M
Displacement [cm ³ /rev]	25.6	40.9	51.1	59.5	81.6	102.9	118.5
Max operating pressure [bar]							
continuous	250	250	250	250	250	250	250
intermittent ¹⁾	350	350	350	350	350	350	350
Max Shaft speed [rpm]							
- continuous	2 300	2 000	1 800	1 700	1 500	1 400	1300
- intermittent	3 000	2 700	2 400	2 200	2 000	1 800	1700
Torque (theor.) [Nm]							
at 200 bar	81	130	162	189	259	327	376
at 350 bar	142	227	284	331	453	572	658
Max output power [kW]	45	64	72	76	95	108	117
Weight [kg]	8.5	8.5	8.5	8.5	12.5	12.5	12.5

1) Max 6 seconds in any one minute.

Ordering code

Example: **F1 - 81 - M**

F1 Motor frame size

25, 41, 51, 61, 81, 101 or 121

Port size

F1 motor frame size	Pressure port ¹⁾
F1-25/41/51/61	¾"
-81/101/121	1"

Standard versions

Designation	Ordering no.
F1-25-M	378 1724
F1-41-M	378 1740
F1-51-M	378 1750
F1-61-M	378 1760
F1-81-M	378 1780
F1-101-M	378 1800
F1-121-M	378 4120

Installation dimensions

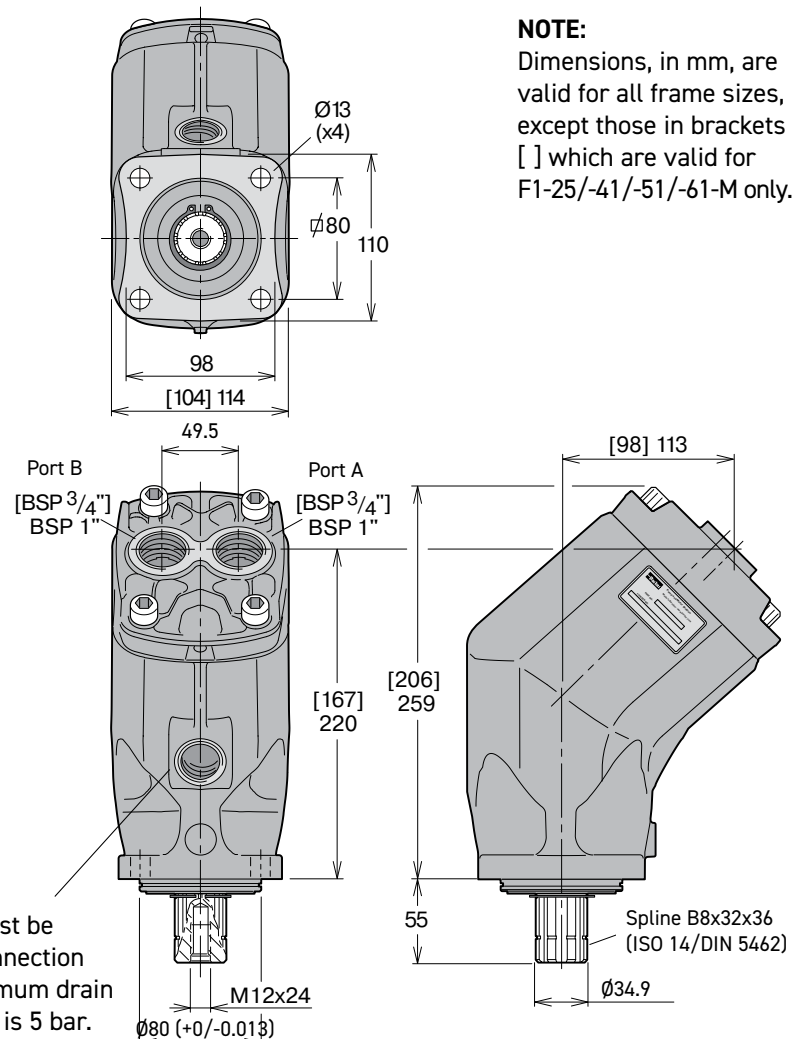

CONTENTS

F2 Twin-flow Pump



Contents	Page
Pump and Line selection.....	14
Specifications.....	44
Installation Dimensions.....	45
Ordering code	45
Standard versions	45
Suction fittings.....	71
Installation and start up	87

TECHNICAL INFORMATION

Specifications

Frame size F2-	42/42	45/45	53/53	55/28	57/57	70/35	70/70
Displacement [cm ³ /rev]							
Port A	43	43	55	55	55	69	68
Port B	41	43	52	28	55	36	68
Max operating pressure [bar] ⁵⁾							
continuous	350	350	350	350	250	350	300
intermittent ²⁾	400	400	400	400	400	400	350
Mass moment of inertia J [kgm ²]	0.0092	0.0092	0.0091	0.0091	0.0090	0.0090	0.0104
Max Shaft speed [rpm]							
(unloaded pump; low pressure)	2550	2550	2550	2550	2550	2550	- ³⁾
Max selfpriming speed [rpm]							
Ports A ¹⁾ and B ¹⁾ pressurised	1800	1800	1800	1800	1800	1800	1650 ⁴⁾
Port A ¹⁾ unloaded, pressure in port B	2100	2100	2100	2100	2100	2100	2100
Max input power ²⁾ [kW]	100	100	127	100	127	126	131
Weight [kg]	19	19	19	19	19	19	19

- Valid at an inlet pressure of 1.0 bar (abs.) when operating on mineral oil at a viscosity of 30 mm²/s (cSt).
- Max 6 seconds in any one minute.
- Not suitable for engine-PTO
- Valid with 3" inlet (suction) line
- We recommend to have the functions with the highest pressure levels on the inner circle, port B.

'Left hand' and 'right hand' end caps

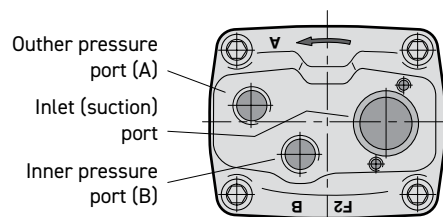

End cap for right hand rotating pump

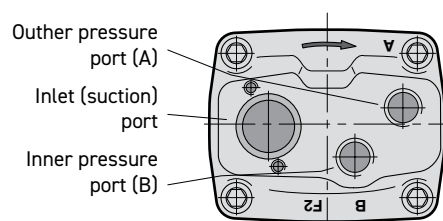

End cap for left hand rotating pump

Flow vs. shaft speed (theoretical)

Pump speed [rpm]	800	1000	1200	1400	1600	1800	1900	2000	2100
F2-53/53 flow [l/min]									
Port A	43	54	65	76	86	97	-	-	-
Port B	42	52	62	73	83	94	99	104	109
Total (ports A + B)	85	106	127	149	169	191	-	-	-
Note: 42/42 values is 80 % of 53/53 values 70/70 values is 130 % of 53/53 values									
F2-70/35 flow [l/min]									
Port A	55	69	83	97	110	124	-	-	-
Port B	29	36	43	50	58	65	68	72	76
Total (ports A + B)	84	105	126	147	168	189	-	-	-
Note: 55/28 values is 80 % of 70/35 values									

Shaft torque vs. pressure (theoretical)

Pressure [bar]	150	200	250	300	350
F2-53/53 torque [Nm]					
Port A	129	171	214	257	300
Port B	124	165	206	248	289
Total (ports A + B)	253	336	420	505	589
Note: 42/42 values is 80 % of 53/53 values 70/70 values is 130 % of 53/53 values					
F2-70/35 torque [Nm]					
Port A	164	219	274	329	383
Port B	86	114	143	171	200
Total (ports A + B)	250	333	417	500	583
Note: 55/28 values is 80 % of 70/35 values					

INSTALLATION DIMENSIONS

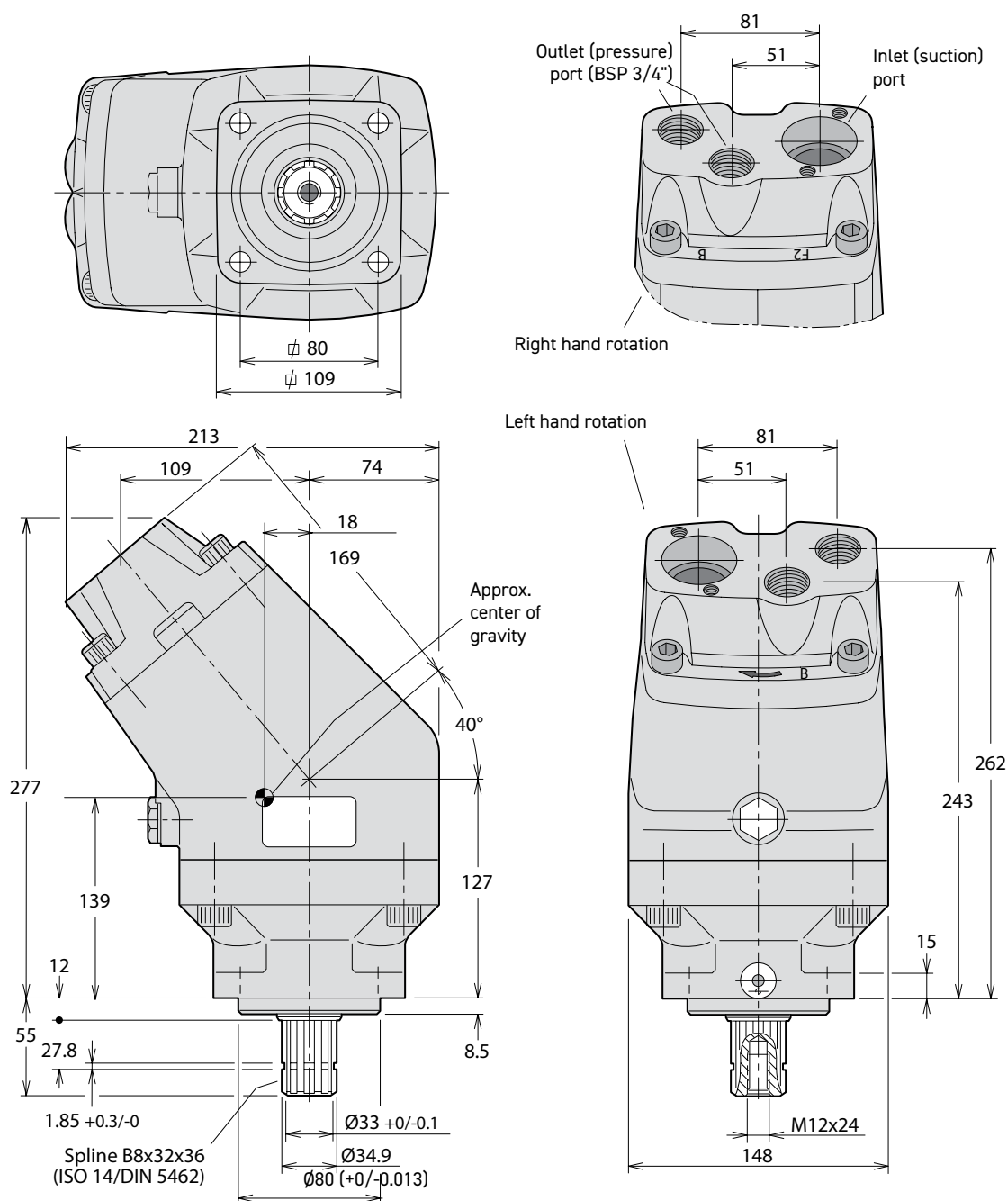

Ordering code

Example: **F2 - 53/53 - L**

Frame size [cm³/rev]

42/42

45/45

53/53

55/28

57/57

70/35

70/70

Direction of rotation

L Left hand

R Right hand

NOTE:

- Before start-up, tighten the inspection port plug to 70 – 100 Nm.
- To change the direction of rotation, the end cap must be replaced.

NOTE:

The pump does not include a suction fitting; it must be ordered separately. See page 72ff.

Standard versions

Designation	Ordering no.
F2-42/42-R	378 4042
F2-42/42-L	378 4043
F2-45/45-R	3725444
F2-45/45-L	3725391
F2-53/53-R	378 1453
F2-53/53-L	378 1454
F2-55/28-R	378 4128
F2-55/28-L	378 4129
F2-57/57-R	3725408
F2-57/57-L	3725389
F2-70/35-R	378 1470
F2-70/35-L	378 1471
F2-70/70-R	378 4070
F2-70/70-L	378 4071

CONTENTS

F3 Pump



Contents	Page
Pump and Line selection	14
Specifications F3-81 and -101	47
Pump cross section	47
BPV-F3 Bypass valve 12 or 24 VDC without manual override	47
Installation Dimensions, F3-81 and -101	48 – 49
Port size	48 – 49
Standard versions	48 – 49
Block diagram engaging the F3 pump and Product Demand	50
Interface	50
Suction fittings	71
Installation and start up	87

TECHNICAL INFORMATION

F3-81 and -101, ISO

Specifications

Frame size F3-	81	101
Displacement [cm ³ /rev]	81.6	102.9
Max flow ¹⁾ [l/min]	180	216
Max operating pressure [bar]	400	400
Shaft speed [rpm]		
- short circuited pump (low press.)	2300	2300
- max selfpriming speed ²⁾	2200	2100
Torque ¹⁾ [Nm]	518	653
Max input power ³⁾ [kW]	105	126
Weight [kg]	20.3	20.1

1) Theoretical values

2) Valid at an inlet pressure of 1.0 bar (abs.) when operating on mineral oil at a viscosity of 30 mm²/s (cSt).

3) Max 6 seconds in any one minute.

NOTE: For noise level information, contact Parker Hannifin.

BPV-F3 Bypass valve 12 or 24 VDC

Without manual override

Bypass valve, type	BPV-F3
Max pressure, continuous	350 bar
intermittent	400 bar
Solenoid voltage	12 or 24 VDC,
Power requirement	14 W
Operating mode	Activated solenoid: Check valve closed

Accessories / Spare Parts see page 73

- As the BPV valve is symmetrical, it can be 'turned 180°' to prevent interference with chassis components; it can be utilised for either left hand or right hand pumps.
- The valve function must only be activated or released (by means of the 24 VDC solenoid) at no-load (below 20 bar) system pressure.

Pump cross section

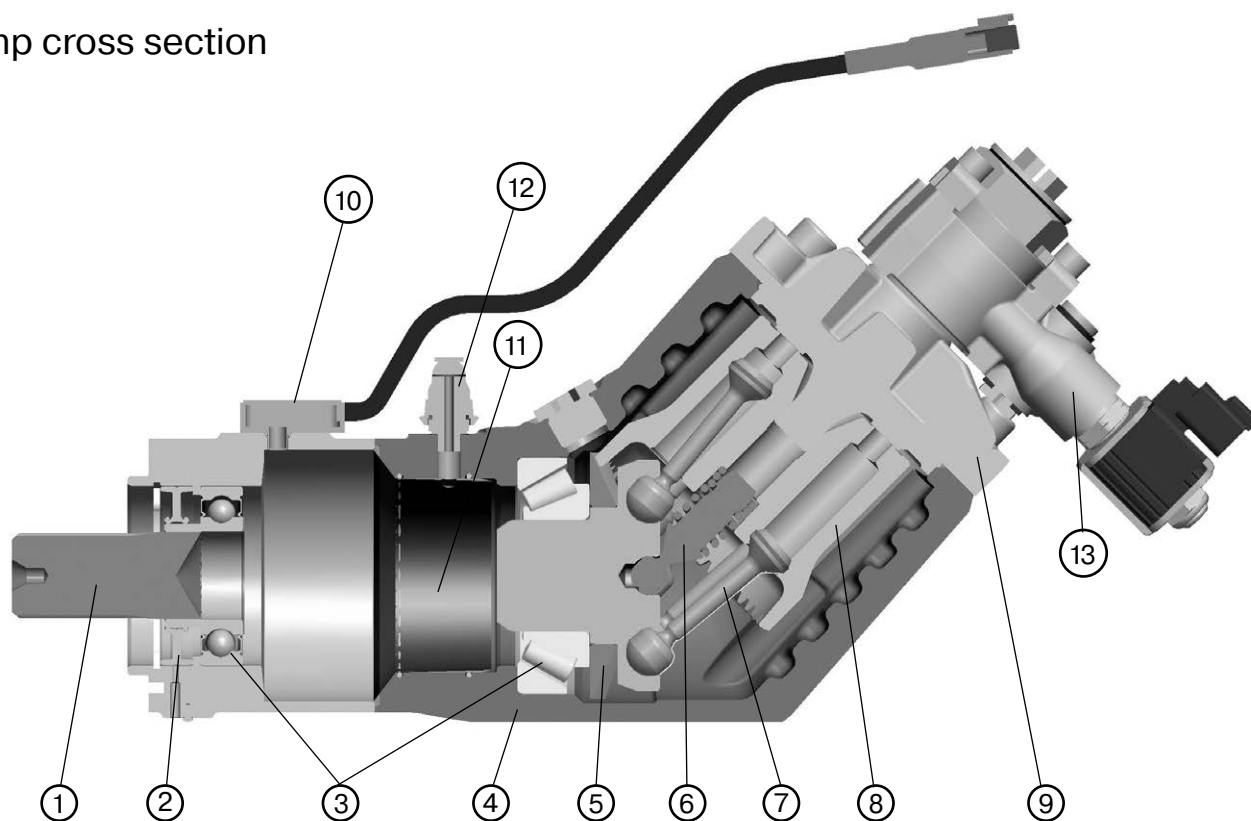

- | | | | |
|----------------|----------------------------|---------------------|------------------|
| 1. Input shaft | 5. Timing gear | 9. End cap | 13. Bypass Valve |
| 2. Shaft seals | 6. Barrel support | 10. Position sensor | |
| 3. Bearings | 7. Piston with piston ring | 11. Air cylinder | |
| 4. Housing | 8. Cylinder barrel | 12. Air fitting | |

INSTALLATION DIMENSIONS

F3-81 and -101

Right hand rotation

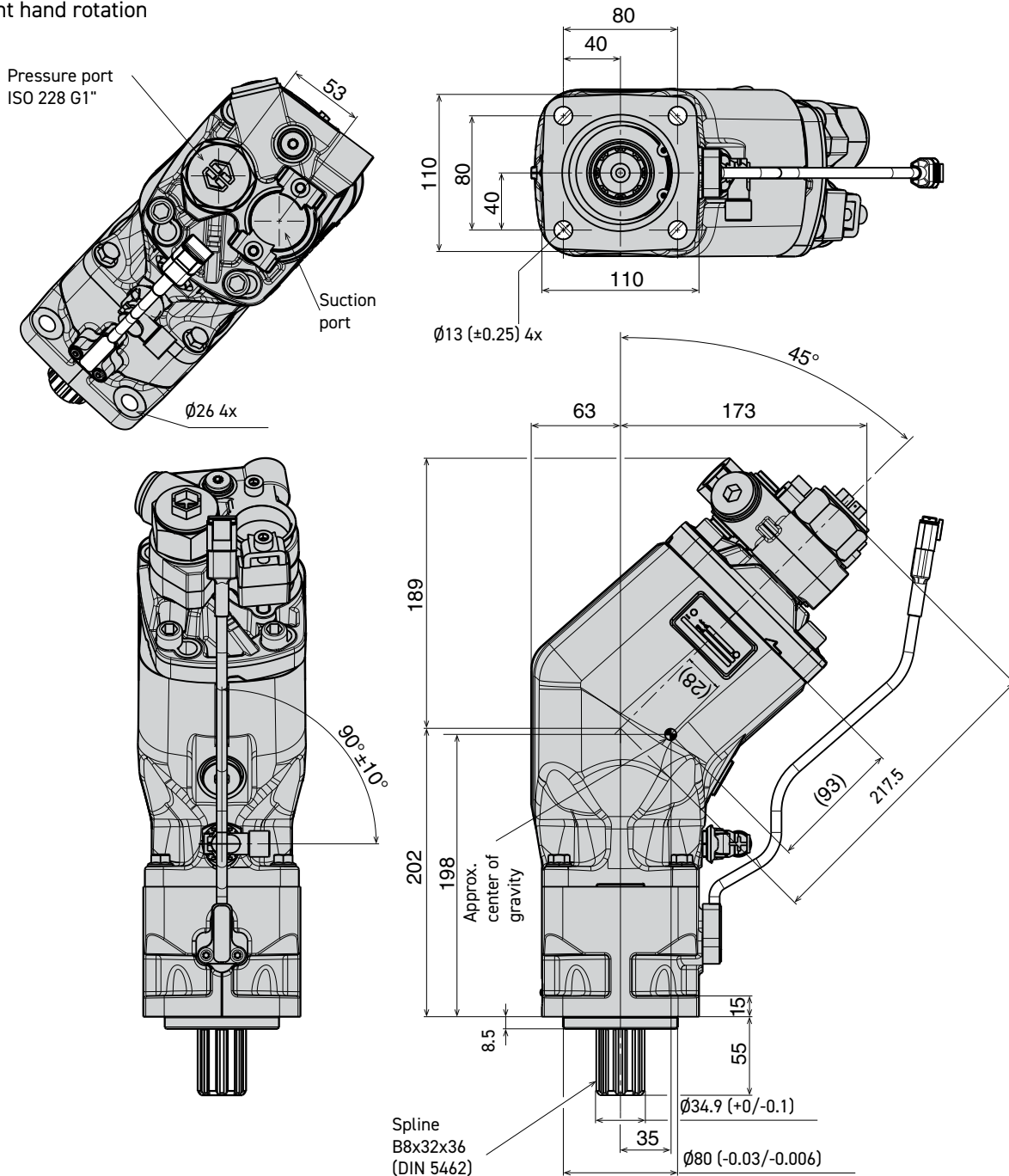

Port size

F3 frame size	Pressure port ¹⁾
-81	1"
-121	1"

1) BSP thread (fitting not included).

Standard versions

Designation	Ordering no. 24 VDC	Ordering no. 12 VDC
F3-81-R-	372 0091	3720382
F3-101-R-	372 0093	3720384

NOTE: The pump does not include a suction fitting; it must be ordered separately. See page 72ff.

F3-81 and -101

Left hand rotation

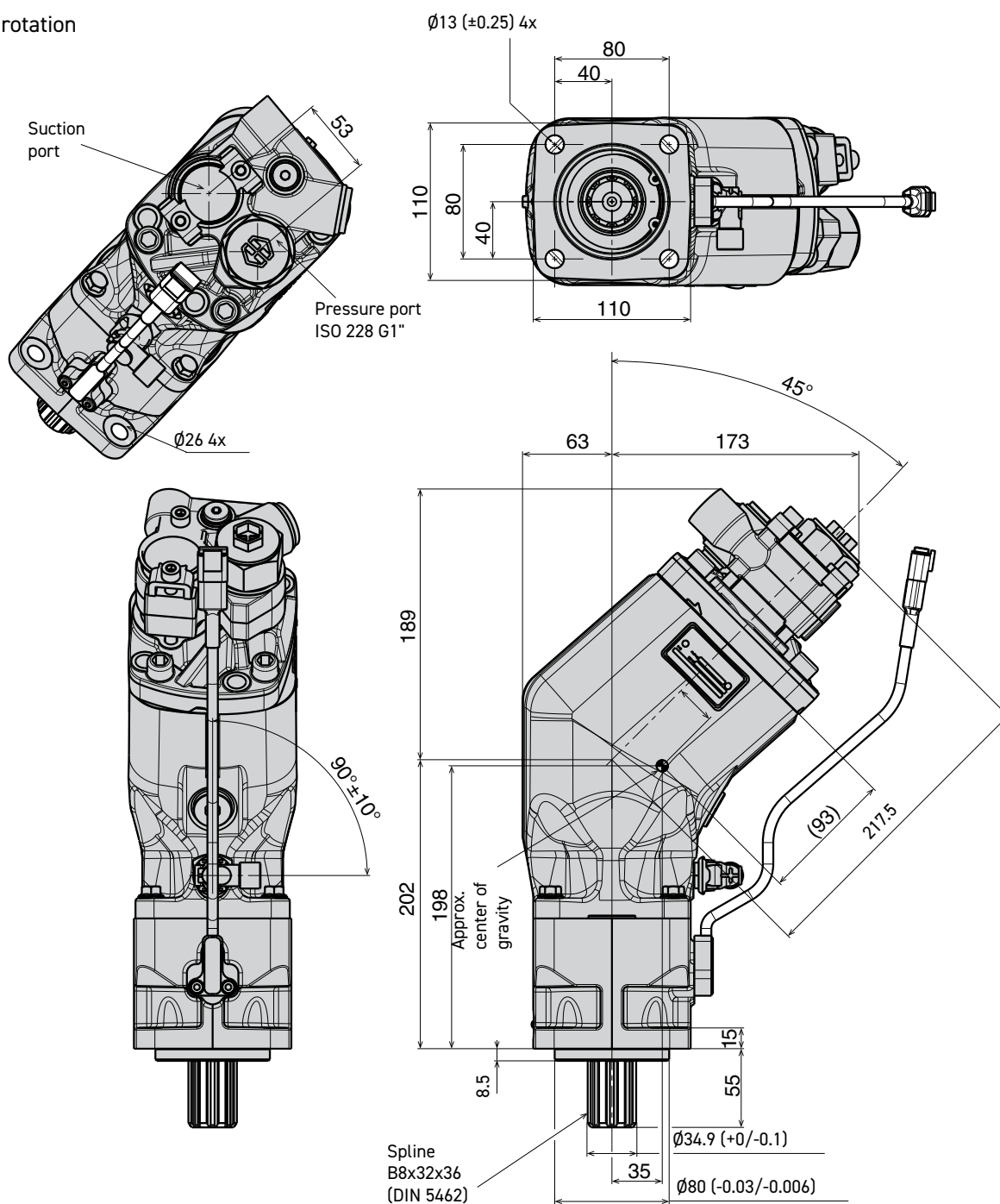

Port size

F3 frame size	Pressure port ¹⁾
-81	1"
-121	1"

1) BSP thread (fitting not included).

Standard versions

Designation	Ordering no.	Ordering no.
	24 VDC	12 VDC
F3-81-L-	372 0092	3720383
F3-101-L-	372 0094	3720385

NOTE: The pump does not include a suction fitting; it must be ordered separately. See page 72ff.

BLOCK DIAGRAM AND PRODUCT DEMAND

Block diagram engaging the F3 pump

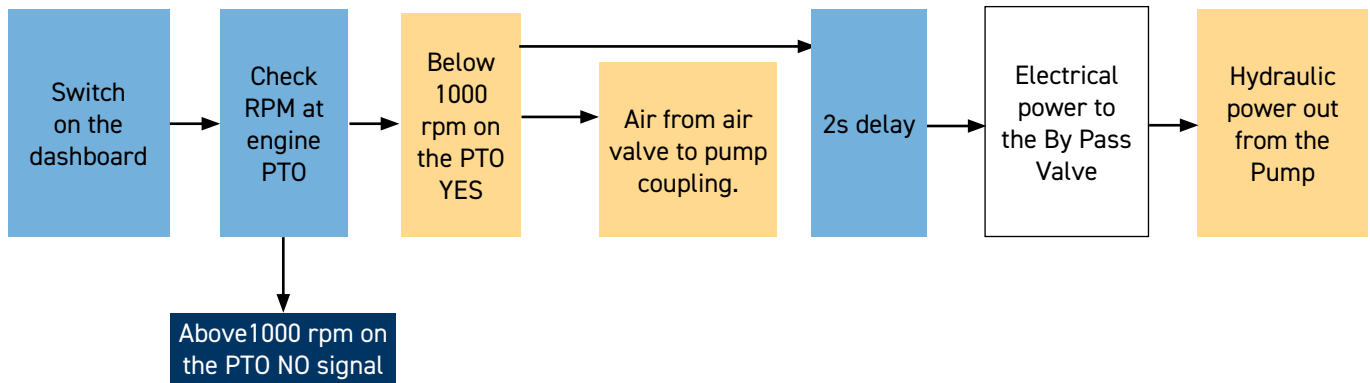

Product Demand

- Max pump shaft speed before the F3 can be engaged is 1000 rpm. (verify engine PTO speed)
- Air pressure > 5 bar before the clutch can start to engage the pump

- * For electrical diagram, contact Parker Hannifin
- * Check the bending torque limit on the PTO mount.
F3 - Bending torque 33 Nm

Interface

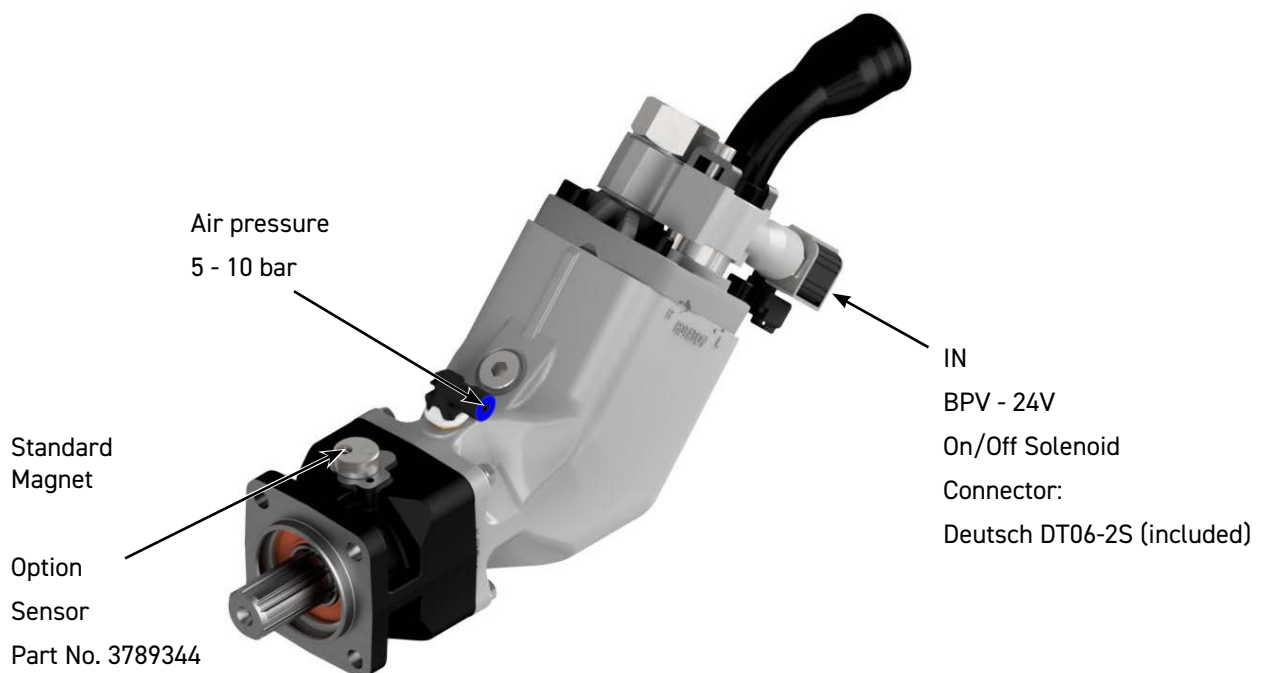

CONTENTS

F4 Pump



Contents	Page
Pump and Line selection.....	14
Specifications.....	52
Pump cross section.....	53
Installation Dimensions and Ordering Code.....	54
Block diagram engaging the F4 pump and Product Demand.....	55
Interface.....	55
Suction fittings.....	71
Installation and start up.....	87

TECHNICAL INFORMATION

Specifications

Frame size F4-	45/45	53/53	57/57	70/35
Displacement [cm ³ /rev]				
Port A	43	55	55	69
Port B	43	52	55	36
Max operating pressure [bar]				
continuous	350	350	350	350
intermittent ²⁾	400	400	400	400
Mass moment of inertia J [kgm ²]	0.0092	0.0091	0.0091	0.0090
Max Shaft speed [rpm]				
(unloaded pump; low pressure)	2550	2550	2550	2550
Max selfpriming speed [rpm]				
Ports A ¹⁾ and B ¹⁾ pressurised	1800	1800	1800	1800
Port A ¹⁾ unloaded, pressure in port B	2100	2100	2100	2100
Max input power ²⁾ [kW]	127	127	127	110
Weight [kg]	29.5	29.5	29.5	29.5

1) Valid at an inlet pressure of 1.0 bar (abs.) when operating on mineral oil at a viscosity of 30 mm²/s (cSt).

2) Max 6 seconds in any one minute.

BPV-F4 Bypass valve 12 or 24 VDC

Without manual override

Bypass valve, type	BPV-F4
Max pressure, continuous	350 bar
intermittent	400 bar
Solenoid voltage	24 VDC,
Power requirement	14 W
Operating mode	Activated solenoid: Check valve closed

Accessories / Spare Parts see page 64.

- It can be utilised for either left hand or right hand pumps.
- The valve function must only be activated or released (by means of the 24 VDC solenoid) at no-load (below 20 bar) system pressure.

Flow vs. shaft speed (theoretical example)

Pump speed [rpm]	800	1000	1200	1400	1600	1800	1900	2000	2100
F4-53/53 flow [l/min]									
Port A	43	54	65	76	86	97	-	-	-
Port B	42	52	62	73	83	94	99	104	109
Total (ports A + B)	85	106	127	149	169	191	-	-	-
F4-70/35 flow [l/min]									
Port A	55	69	83	97	110	124	-	-	-
Port B	29	36	43	50	58	65	68	72	76
Total (ports A + B)	84	105	126	147	168	189	-	-	-

Shaft torque vs. pressure (theoretical example)

Pressure [bar]	150	200	250	300	350
F4-53/53 torque [Nm]					
Port A	129	171	214	257	300
Port B	124	165	206	248	289
Total (ports A + B)	253	336	420	505	589
F4-70/35 torque [Nm]					
Port A	164	219	274	329	383
Port B	86	114	143	171	200
Total (ports A + B)	250	333	417	500	583

Pump cross section

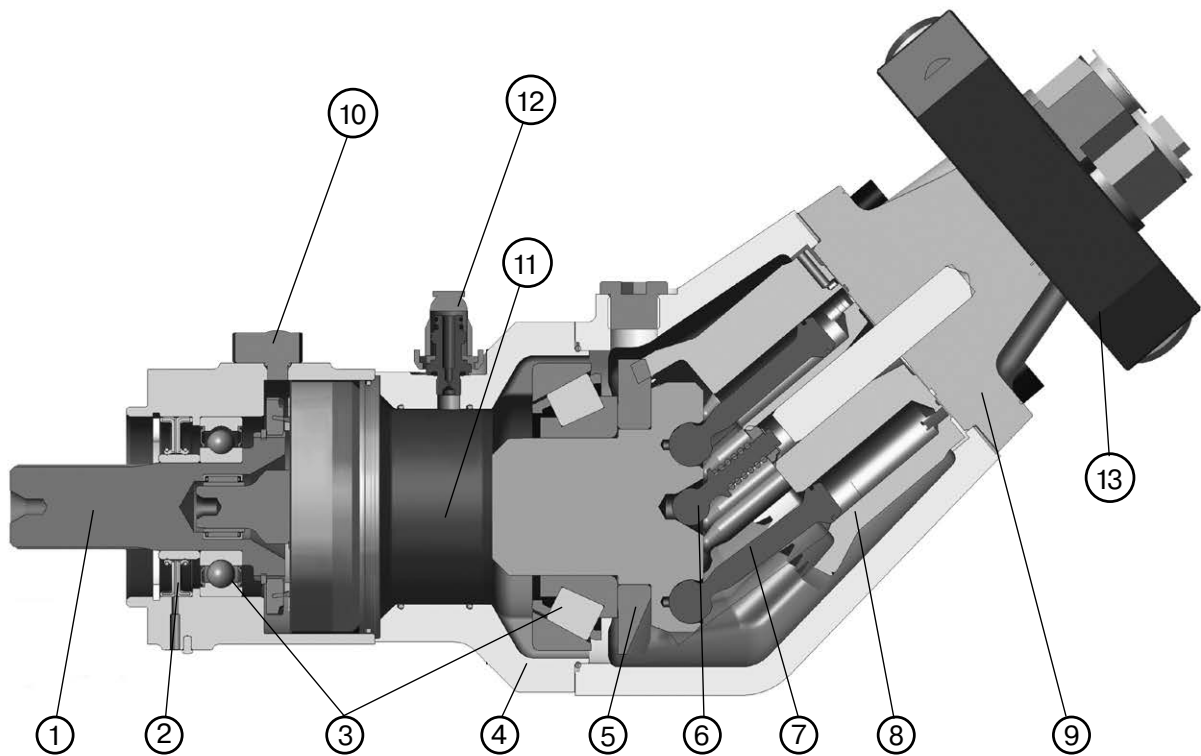

1. Input shaft
2. Shaft seals
3. Bearings
4. Housing

5. Timing gear
6. Barrel support
7. Piston with piston ring
8. Cylinder barrel

9. End cap
10. Magnet
11. Air cylinder
12. Air fitting

13. Bypass Valve

INSTALLATION DIMENSIONS

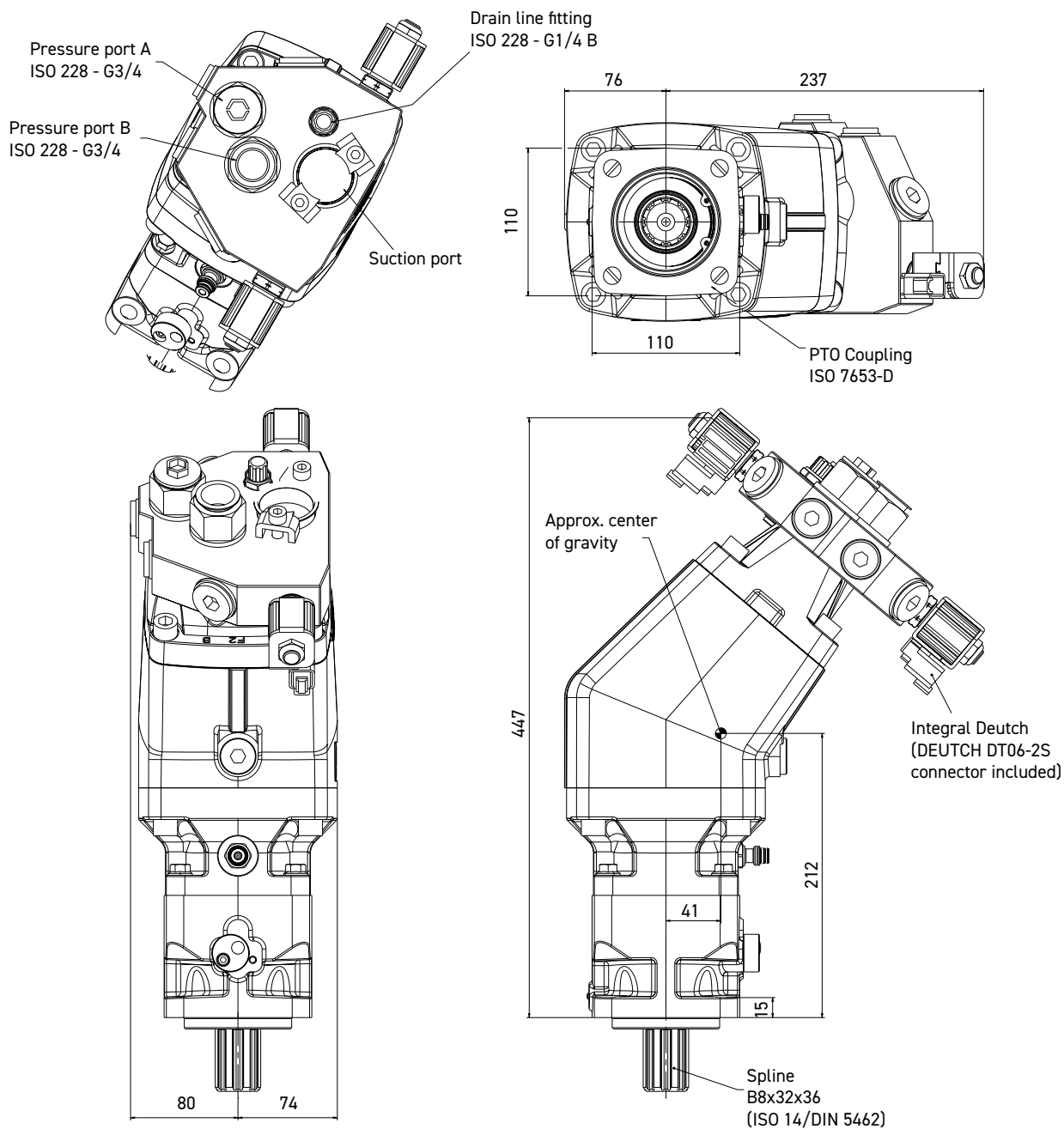

Ordering code

Example: **F4 - 53/53 - L**

Frame size [cm³/rev] ————

53/53

45/45

57/57

70/35

Direction of rotation ————

L Left hand

R Right hand

NOTE:

- Before start-up, tighten the inspection port plug to 70 – 100 Nm.
- To change the direction of rotation, the end cap must be replaced.

NOTE:

The pump does not include a suction fitting; it must be ordered separately. See page 72ff.

Standard versions

Designation	Ordering no.
F4-45/45-L	3725443
F4-45/45-R	3725442
F4-53/53-L	3724263
F4-53/53-R	3724262
F4-57/57-L	3725241
F4-57/57-R	3725407
F4-70/35-L	3724264
F4-70/35-R	3724153

BLOCK DIAGRAM AND PRODUCT DEMAND

Block diagram engaging the F4 pump

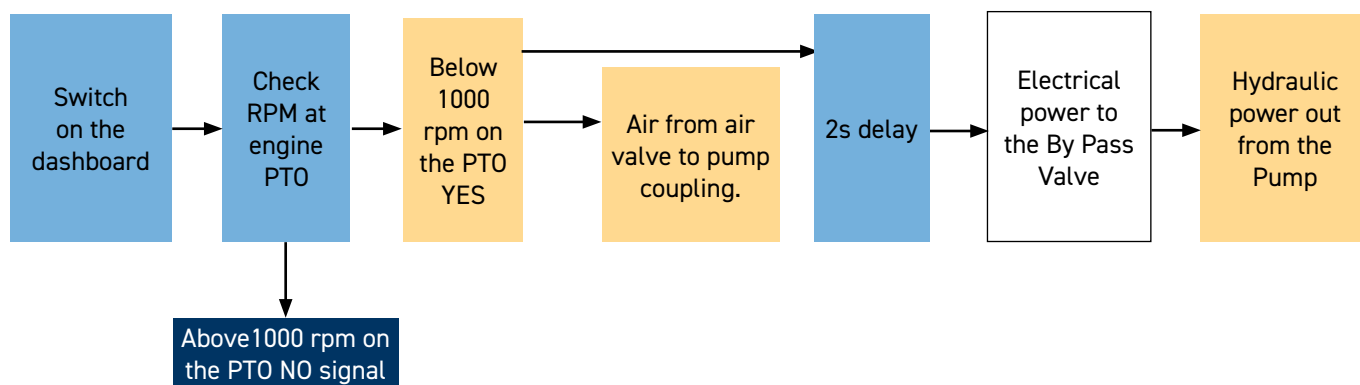

Product Demand

- Max pump shaft speed before the F4 can be engaged is 1000 rpm. (verify engine PTO speed)
- Air pressure > 5 bar before the clutch can start to engage the pump

- * For electrical diagram, contact Parker Hannifin
- * Check the bending torque limit on the PTO mount.
F4 - Bending torque 60 Nm

Interface

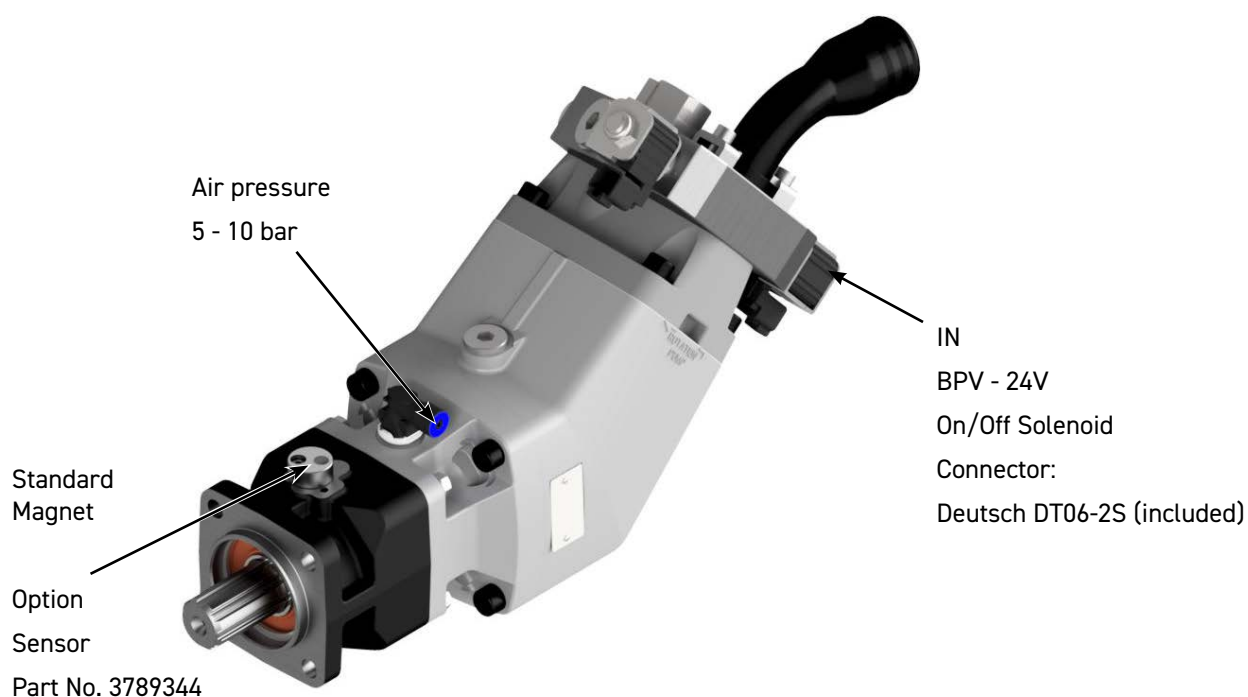

CONTENTS

VP1 Pump



Contents	Page
Pump and Line selection.....	14
Specifications.....	58
VP1-045/-060/-075 cross section	58
LS valve block VP1-045/-060/-075	59
Through-shaft coupling VP1-045/-060/-075	59
Installation Dimensions, VP1-045, -060 and -075.....	60
VP1-095/-110/-130 cross section.....	61
Installation Dimensions, VP1-095/-110/-130.....	62
LS control (for VP1-095/-110/-130)	63
Ordering information	66
System Information	67
VP1 in load sensing systems and Systems comparison	67
LS load sensing control function and LS control adjustments	68
Suction fittings.....	71
Installation and start-up for VP1	91

TECHNICAL INFORMATION

Specifications

Frame size VP1-	045	060	075	095	110	130
Displacement [cm ³ /rev]	45	60	75	95	110	128
Max operating pressure [bar]						
continuous	350	350	350	400	400	400
intermittent ¹⁾	400	400	400	420	420	420
Mass moment of inertia J [kgm ²]	0.00606	0.00606	0.00606	0.00681	0.00690	0.00690
Shaft speed ²⁾ [rpm]						
- short circuited pump (low press.)	3000	3000	3000	3000	3000	3000
- max selfpriming speed ²⁾	3000	2700	2500	2300 ³⁾	2200 ³⁾	2100 ³⁾
Control type	LS					
Shaft end spline	DIN 5462					
Mounting flange	ISO 7653-1985					
Weight (with control) [kg]	27					

1) Max 6 seconds in any one minute.

2) At an inlet pressure of 1.0 bar (abs.) with mineral oil at a viscosity of 30 mm²/s (cSt).

3) Valid with 3" inlet (suction) line

VP1-045/-060/-075 cross section

1. Inlet port
2. 'Top' purge plug
3. Return spring
4. Control
5. Setting piston (one of two)
6. Swash plate
7. Bearing shell
8. End cover
9. Spline (for mounting an auxiliary pump)
10. Plain bearing
11. Hold-down plunger
12. Valve plate
13. Cylinder barrel
14. Barrel housing
15. 'Bottom' purge plug
16. Piston with piston shoe
17. Retainer plate
18. Bearing housing
19. Roller bearing
20. Shaft seals with carrier
21. Input shaft

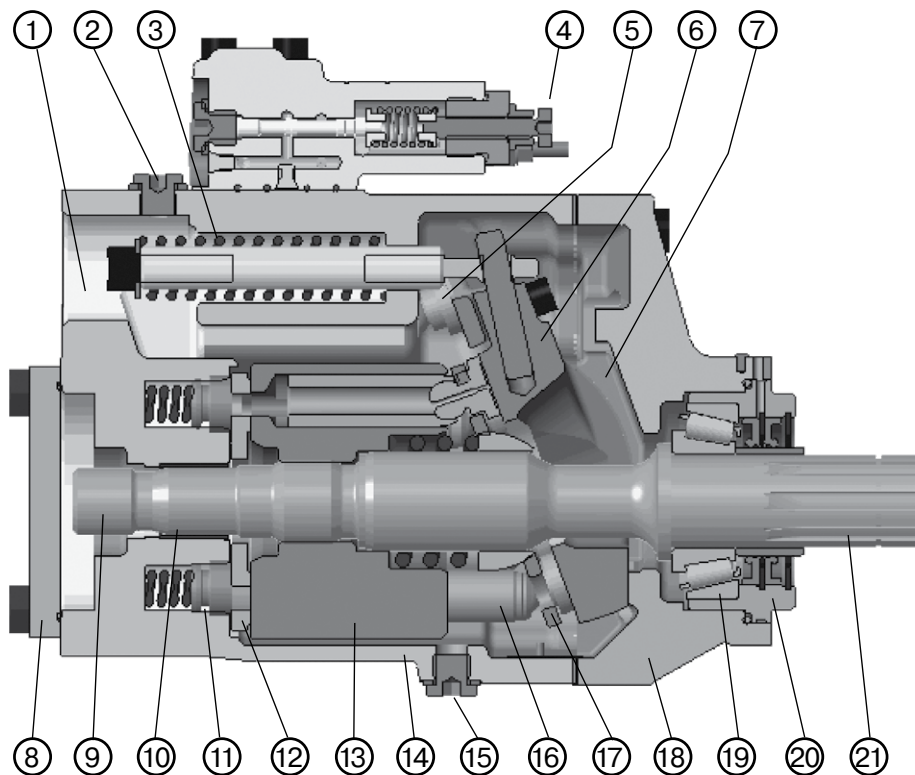

LS valve block VP1-045/-060/-075

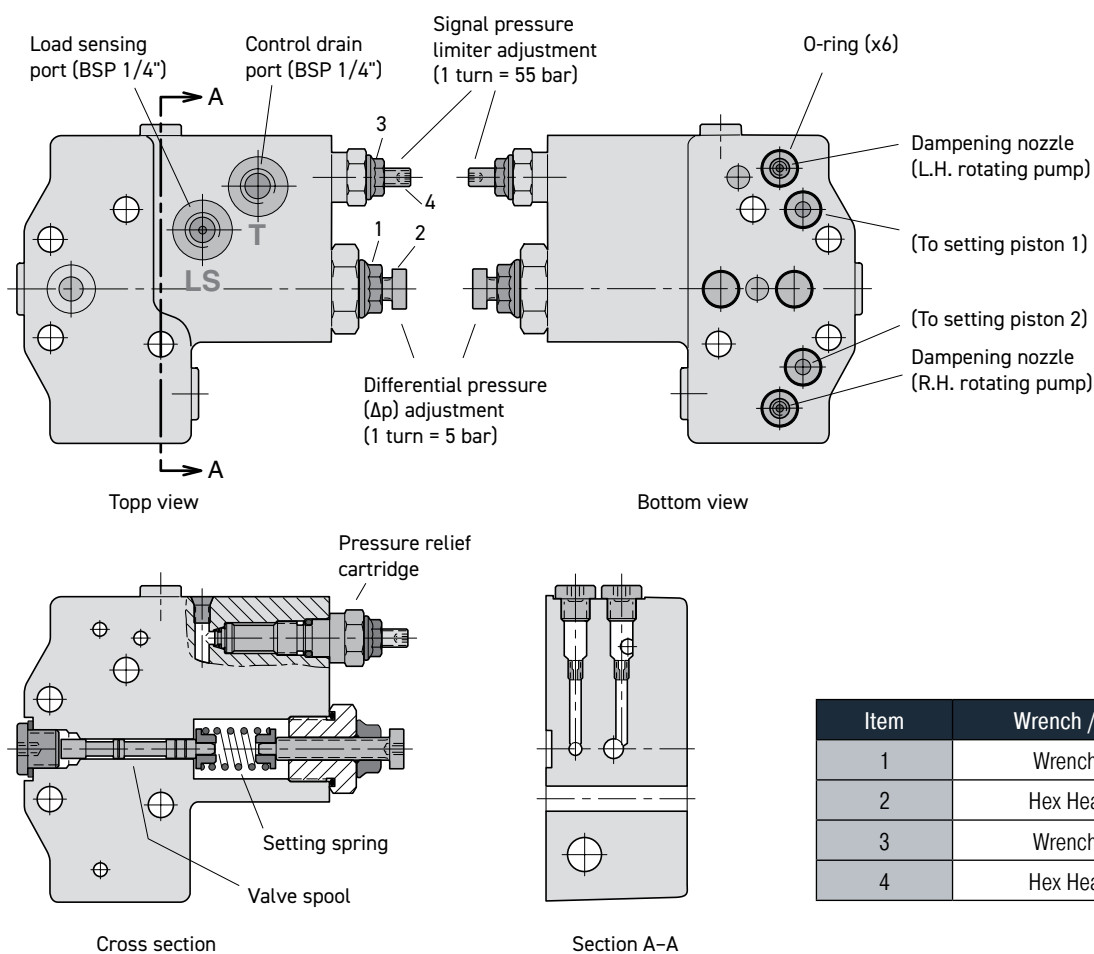

Fig. 2. LS valve block.

Through-shaft coupling VP1-045/-060/-075

The VP1 pump has a through-shaft which means that an additional pump, such as a fixed displacement F1, can be installed in tandem with the VP1 by means of an adaptor kit (fig. 3).

NOTE:

The bending moment caused by the weight of a tandem assembly normally exceeds that allowed by the PTO.

To prevent damage, the auxiliary pump should be supported by a bracket attached to the gearbox; it must not be fastened to the truck chassis.

Likewise, when the tandem assembly is installed on a separate bracket and driven by a cardan shaft, the auxiliary pump should have a support attached to the pump bracket.

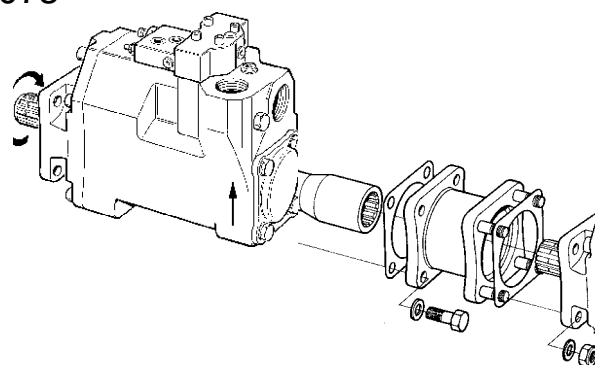

Fig. 3. Adaptor kit (P/N 379 7795) for tandem coupling.

IMPORTANT

Contact Parker Hannifin for additional information when considering tandem mounting a second VP1 pump.

The maximum torque that can be transmitted through the first pump VP1-045/-060/-075 in tandem is 420 Nm.

INSTALLATION DIMENSIONS

VP1-045, -060 and -075

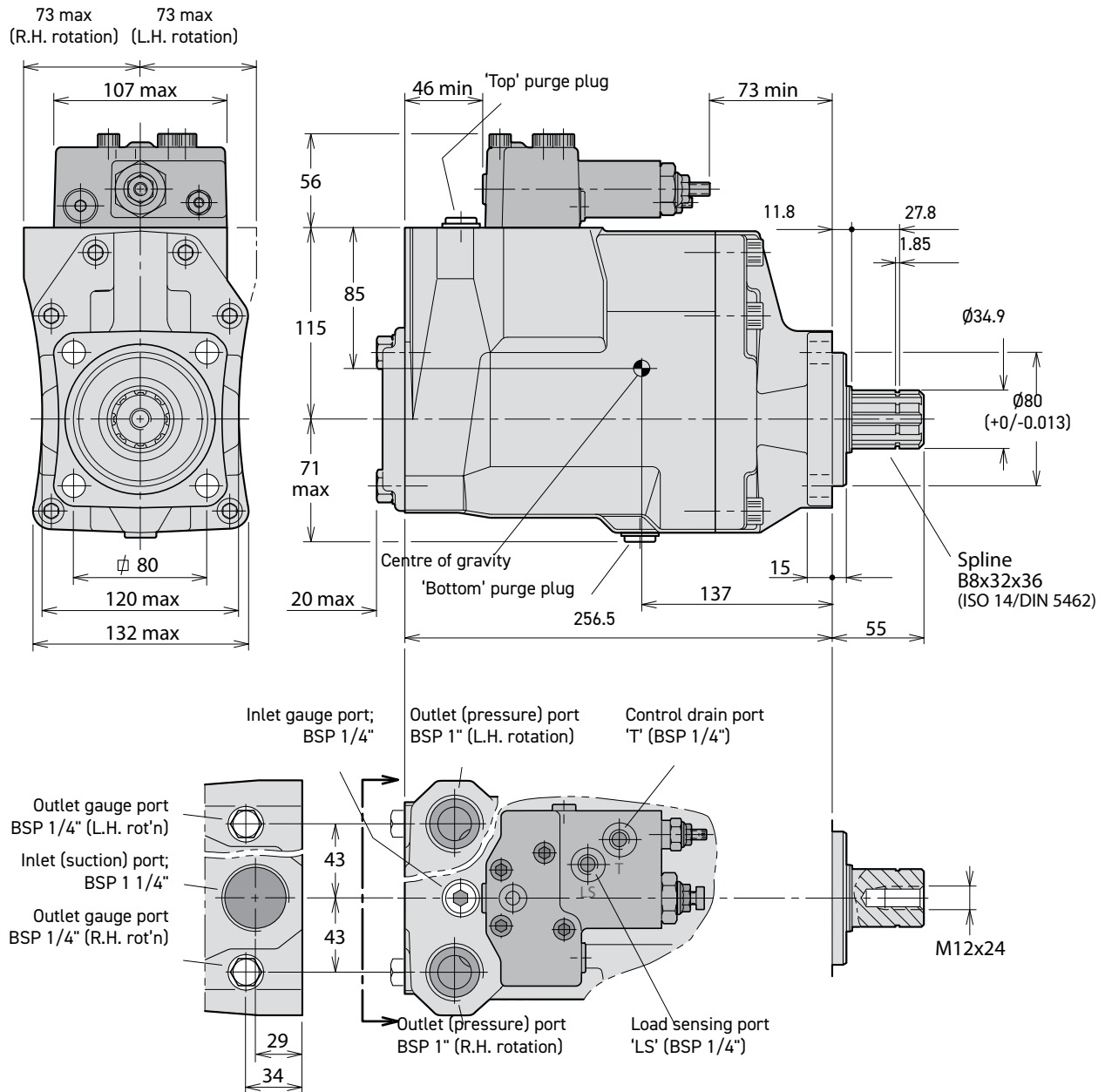

IMPORTANT

The control is not drained through the pump case. An external line must be installed between the control drain port 'T' and the reservoir.

NOTE: The pump does not include a suction fitting; it must be ordered separately. See page 72ff.

TECHNICAL INFORMATION

VP1-095/-110/-130

VP1-095/-110/-130 cross section

1. Shaft seal
2. Roller bearing
3. 'Upper' purge plug
4. Bearing shell
5. Setting screw (pressure relief valve)
6. Setting bushing (standby pressure)
7. Control
8. Piston with piston shoe
9. 'Upper' setting piston (control pressure)
10. Needle bearing
11. Shaft
12. Drain hole, shaft seals
13. 'Lower' purge plug
14. Bearing housing
15. Swash plate
16. Retainer plate
17. 'Lower' setting piston (pump pressure)
18. Cylinder barrel
19. Valve plate
20. Barrel housing

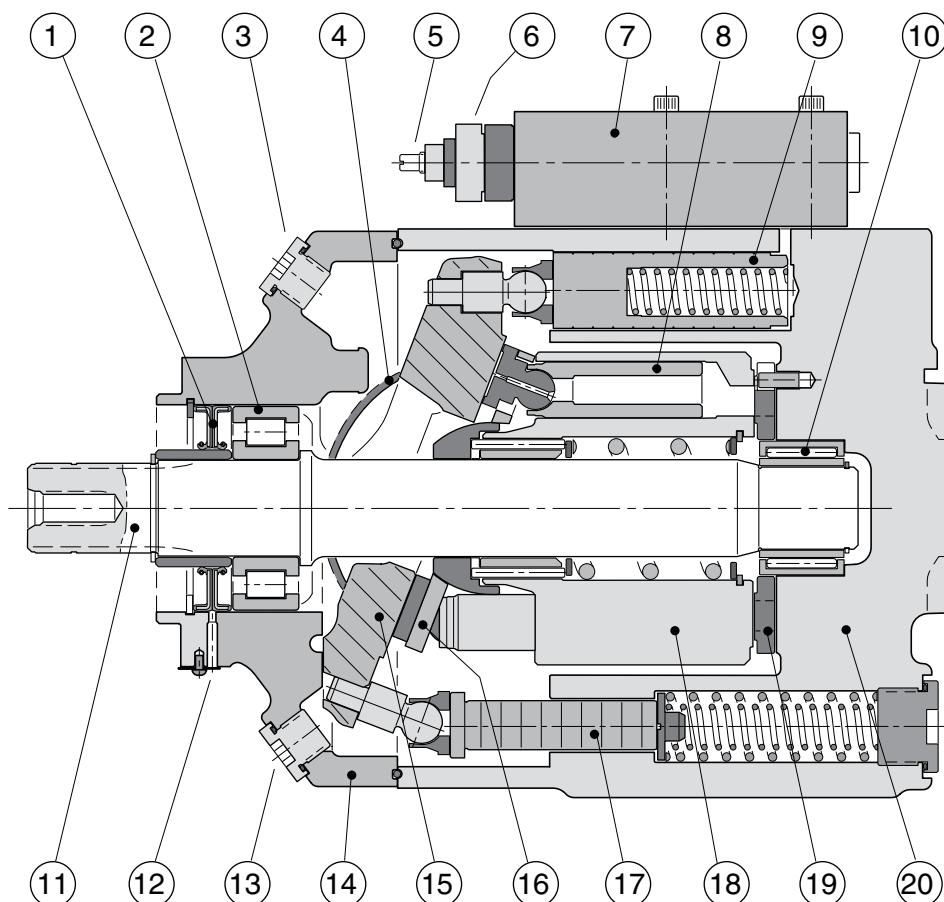

INSTALLATION DIMENSIONS

VP1-095/-110/-130

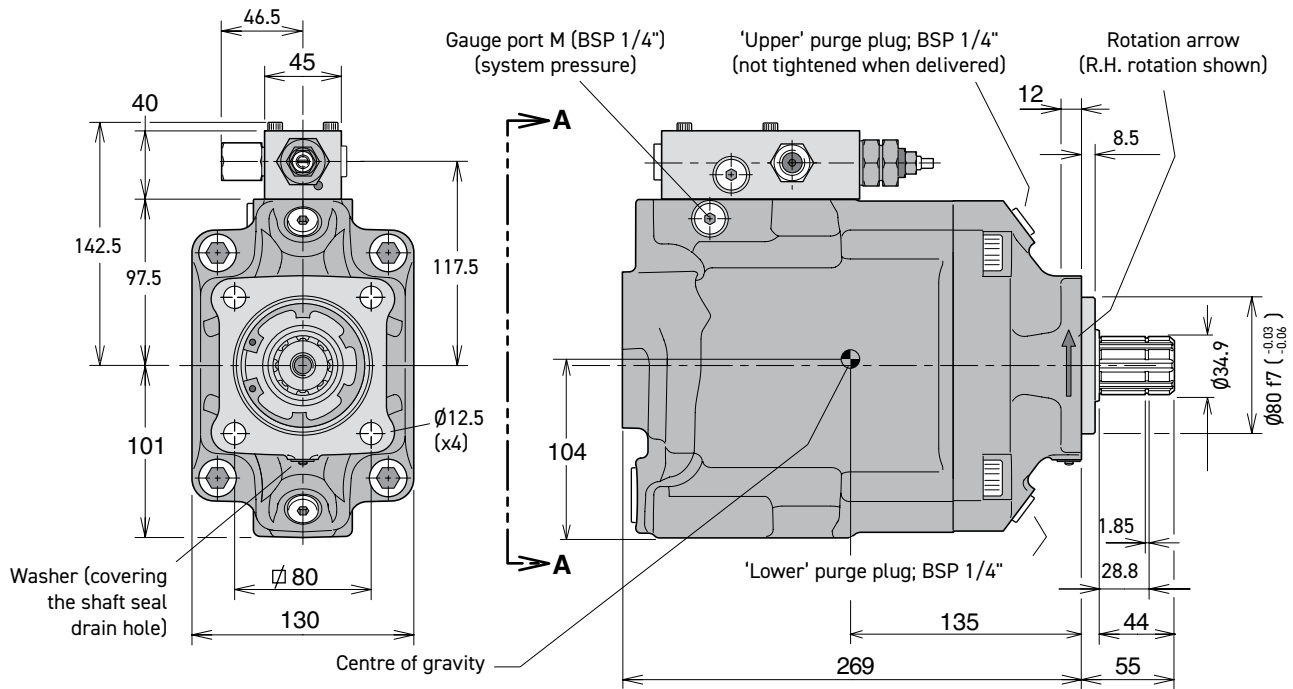

NOTE:

The pump does not include a suction fitting; it must be ordered separately. See page 63ff.

IMPORTANT!

The control is not drained through the pump case; an external drain line must be installed from control port T and, directly, to the oil tank.

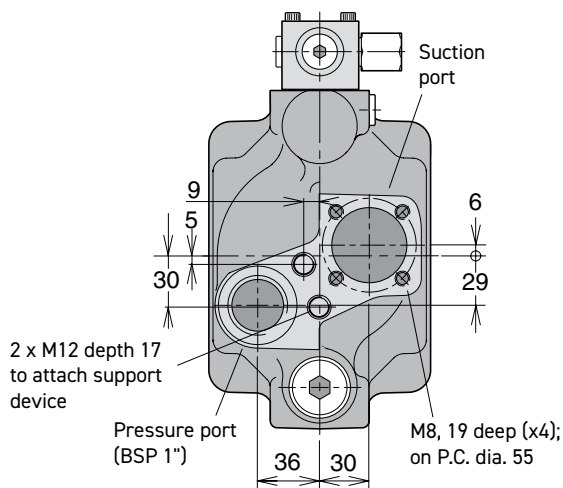
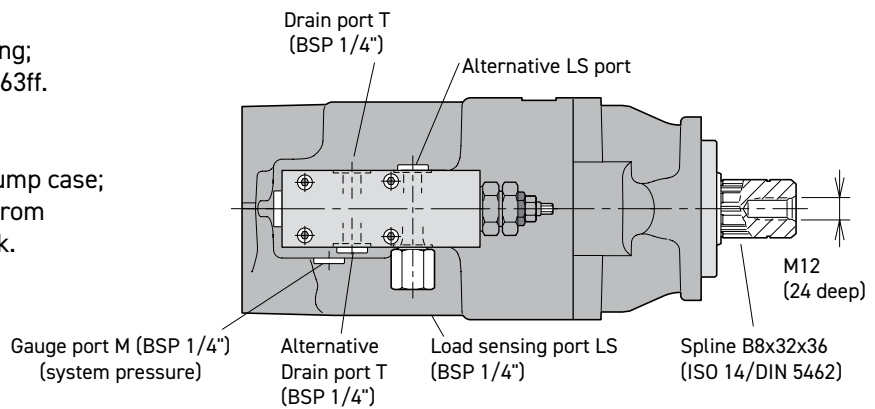

View A-A

Left hand rotating pump

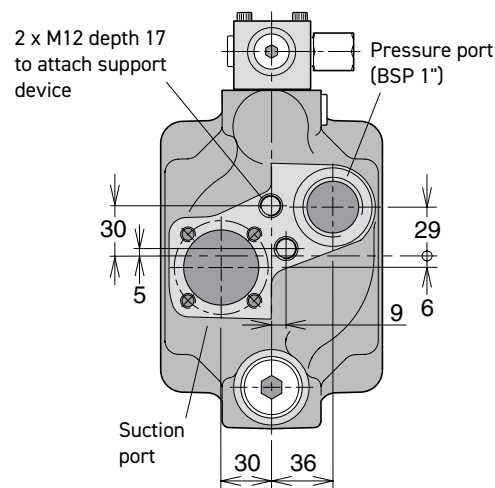

View A-A

Right hand rotating pump

LS control (for VP1-095/-110/-130)

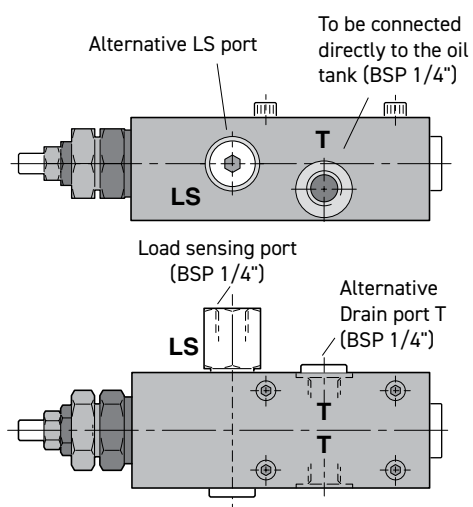

LS control ports.

NOTE:

Always run a function, after adjusting the standby pressure or the max pressure setting, before you read the value.

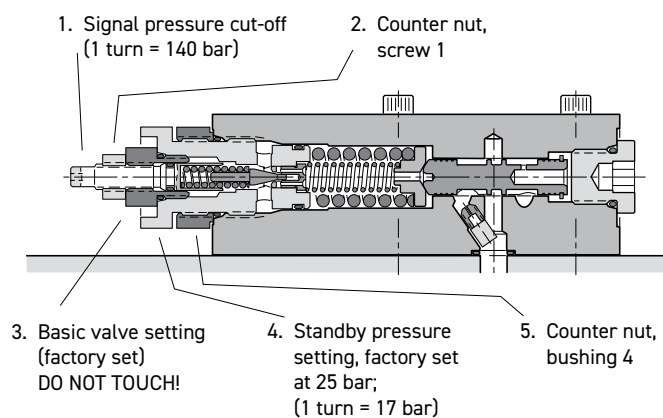

LS control cross section.

Item	Wrench / dimension
1	Hex Head Wrench / 4 mm
2	Wrench / 13 mm
3	DO NOT TOUCH
4	Wrench / 27 mm
5	Wrench / 27 mm

TECHNICAL INFORMATION

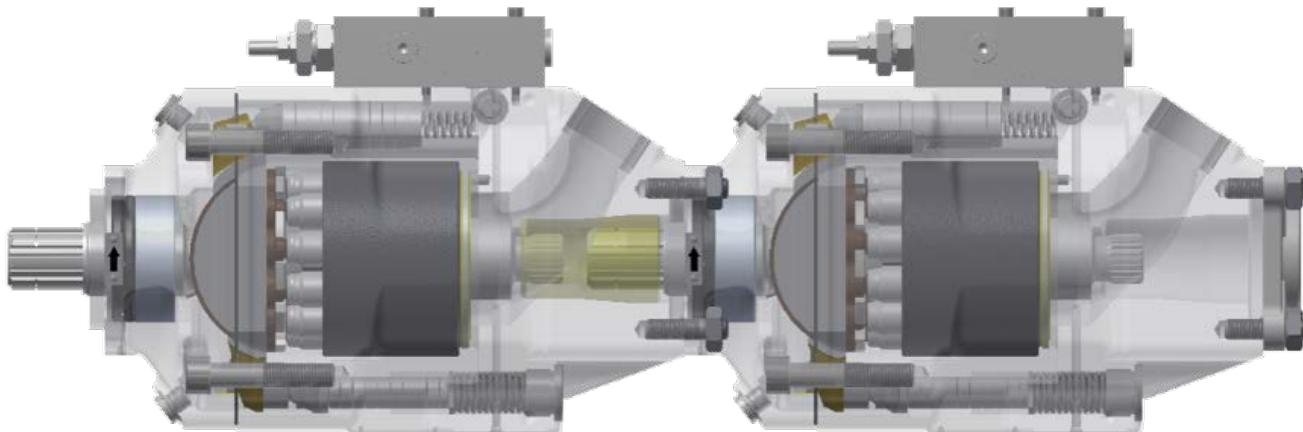

95/110/130 With Through Drive

VP1 Axial Piston Pump: Elevate your mobile hydraulics! Unlock the full potential of your hydraulic systems with the VP1 axial piston pump. Designed specifically for open circuits in mobile hydraulics, this pump operates seamlessly according to the swash plate principle, ensuring optimal performance and efficiency.

New Feature! The VP1 is now available with an innovative thru-shaft option, allowing you to operate additional hydraulic pumps in series. This enhancement not only increases versatility but also maximizes your system's capabilities.

Upgrade to the VP1 axial piston pump today and experience the perfect blend of reliability and advanced engineering for your mobile hydraulic applications.

Features and benefits:

- Optimized power-to-weight ratio
- Slim design
- Thru-shaft compatibility
- High selfpriming speed

Intended applications:

- Municipal trucks
- Loading cranes and elevating work platforms
- Tipper trucks and skip trucks
- Suction dredgers and sewer cleaning vehicles
- Refuse collection vehicles

Specifications

Frame size VP1-	095	110	130
Displacement [cm ³ /rev]	95	110	128
Max operating pressure [bar]			
continuous	400	400	400
intermittent	420	420	420
Mass moment of inertia J [kgm ²]	0.00696	0.00705	0.00705
Shaft speed [rpm]			
- short circuited pump (low press.)	3000	3000	3000
- max selfpriming speed	2300	2200	2100
Max input torque [Nm]	900	900	900
Max through drive torque [Nm]	720	720	720
Control type	LS		
Shaft end spline	DIN 5462		
Through drive spline	DIN 5462		
Mounting flange	ISO 7653-1985		
Weight (with control) [kg]	32		

INSTALLATION DIMENSIONS

95/110/130 With Through Drive

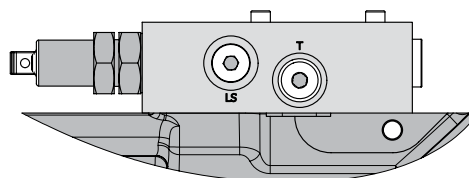
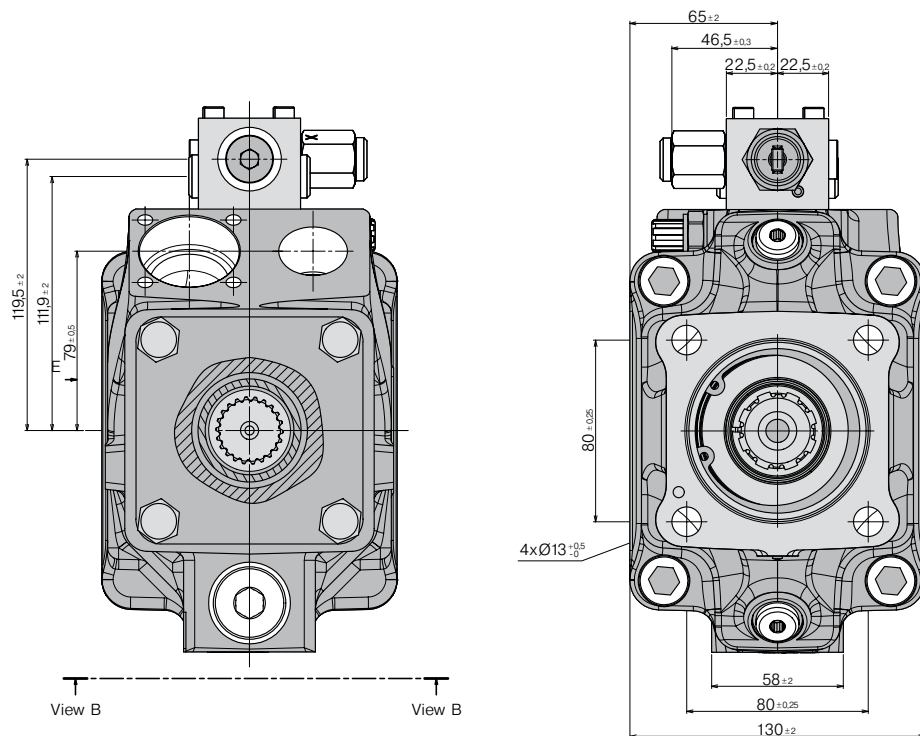
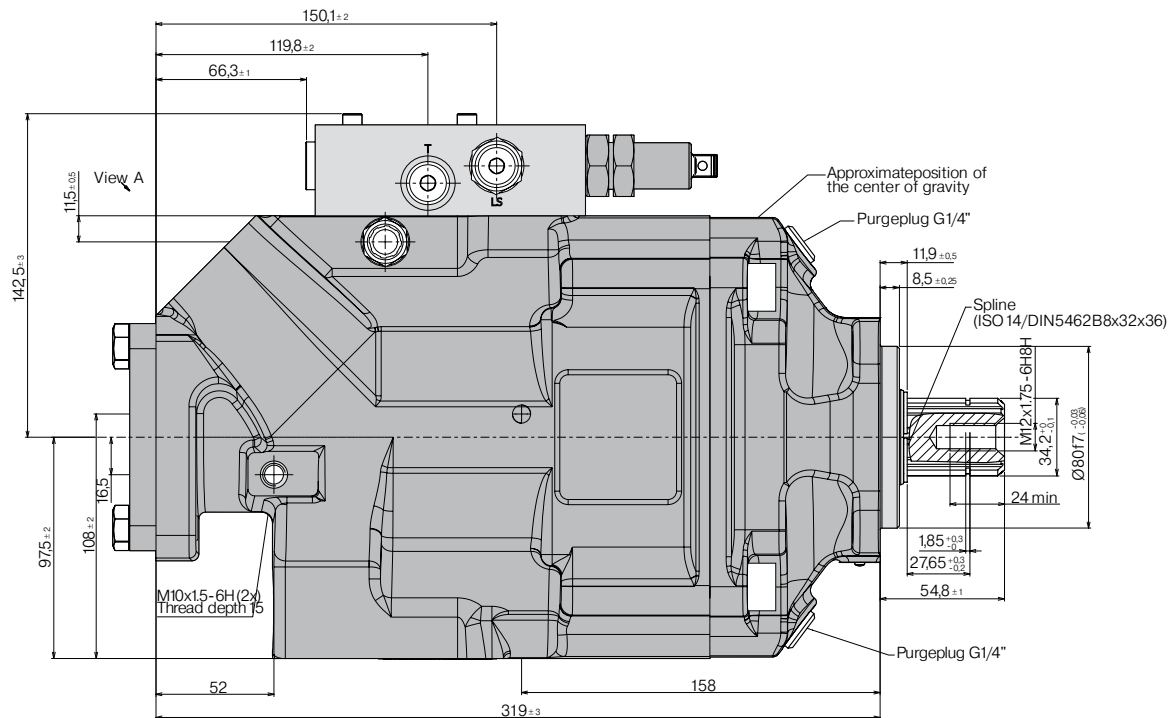

PRODUCT DESIGNATION

Ex **VP1** **130** **R** **A** - **Z** **O** - **T** - **000** - **350 / 25** - **LS**

Frame Size Rotation Ports Interface Housing Paint Special-number Pressure cut-off Pressure Standby Regulator

Frame Size	
Code	Dicplacement
45	45
60	60
75	75
95	95
110	110
130	130

Frame Size	
Code	Dicplacement
R	Right
L	Left

Frame Size		45	60	75	95	110	130
Code	Dicplacement						
G	BSP Therds	S	S	S	O	O	O
A	No Therds	-	-	-	S	S	S

Frame Size		45	60	75	95	110	130
Code	Interface						
Z	ISO flange & shaft. G1 thread in press. Port	S	S	S	O	O	O
C	SAE C flange & shaft. UNI thread in press. Port	-	-	-	S	S	S
B	*SAE B flange, SAE B-B shaft. UNI thread in press. Port	-	-	-	S	S	S

* 210 bar pressure cut-off limit

Frame Size		45	60	75	95	110	130
Code	Housing						
P	Through shaft	S	S	S	O	O	O
O	Singel pump	-	-	-	S	S	S

Frame Size	
Code	Paint
T	Standard Black
O	No Paint

Frame Size		45	60	75	95	110	130
Code	Regulator						
LS	Std. LS	S	S	S	S	S	S
E1	EPC1 *	O	O	O	O	O	O
E2	EPC2 **	O	O	O	O	O	O

* 24V, Normally Open, Deutsch contact

** 24V, Normally Closed, Deutsch contact

(S) = Standard (O) = Option (-) = Not Available

* Customer specific demands, please contact Parker Hannifin

SYSTEM INFORMATION

Standard model numbers

Designation	Ordering no. No Paint	Ordering no. Black Paint
VP1-045-R-LS	378 0334	378 6169
VP1-045-L-LS	378 0335	378 6170
VP1-060-R-LS	372 2283	372 2285
VP1-060-L-LS	372 2284	372 2286
VP1-075-R-LS	378 0336	378 6171
VP1-075-L-LS	378 0337	378 6172
VP1-095-R-LS	378 6000	378 6003
VP1-095-L-LS	378 6001	378 6002
VP1-110-R-LS	378 4110	378 3814
VP1-110-L-LS	378 4111	378 3815
VP1-130-R-LS	378 4500	378 4507
VP1-130-L-LS	378 4501	378 4508

* LS = Hydraulic Load Sensing

VP1 in load sensing systems

When installed in a load sensing system, the VP1 supplies the correct amount of flow required by the various work functions currently engaged.

This means that energy consumption and heat generation are minimised and much reduced in comparison with a fixed displacement pump used in the same system.

Diagram 1 shows the required power (flow times pressure) in a constant flow system with a fixed displacement pump.

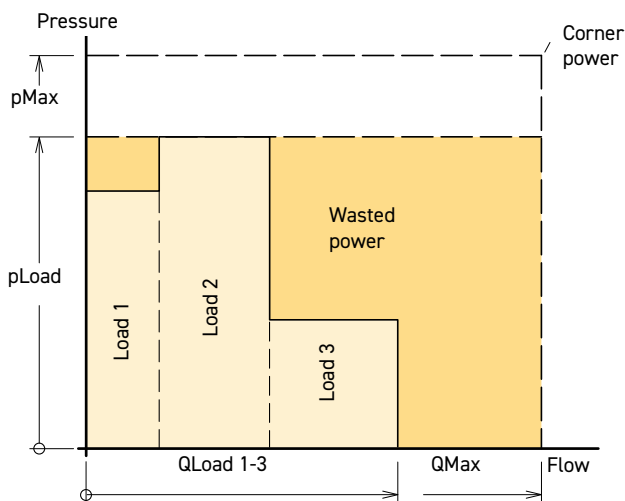

Diagram 1. Constant flow system with a fixed displacement pump.

VP1- Through Shaft

Designation VP1- Through Shaft	Ordering no. Black Paint
VP1-095-R-LS	3723519
VP1-095-L-LS	3723520
VP1-110-R-LS	3723521
VP1-110-L-LS	3723522
VP1-130-R-LS	3724134
VP1-130-L-LS	3724135

* LS = Hydraulic Load Sensing

Diagram 2 shows the sharply reduced power requirement in a load sensing system with a variable displacement pump such as the VP1.

In both cases the pump pressure is slightly higher than what is required by the heaviest load ('Load 2') but the VP1, because of the much smaller flow being delivered, needs only the power indicated by the shaded area 'Load power'.

In a constant flow system, on the other hand, excess fluid is shunted to tank and the corresponding power, 'Wasted power' (shown in diagram 1), is a heat loss.

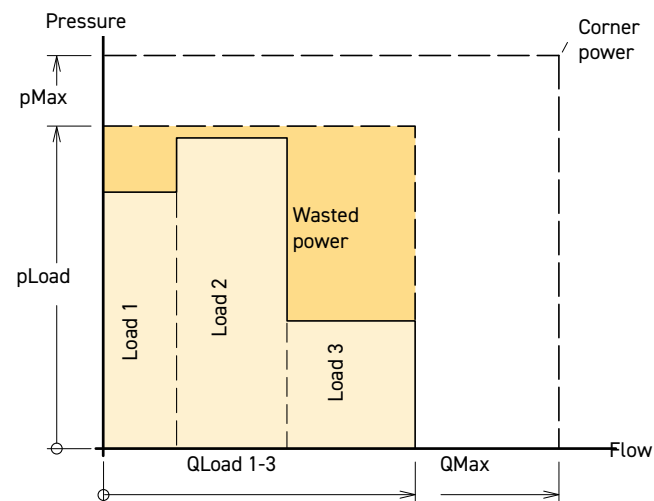

Diagram 2. Constant flow system with a variable displacement pump (e.g. VP1).

Systems comparison

System	Constant flow	Load-sensing
Pump	Fixed displ.	VP1 variable displ.
Pump adjustments	Pressure only	Pressure and flow
Load*	Some influence	Some influence
Energy consumption	High	Low
Heat generation	High	Low

* Simultaneous operation of loads with non-equal flows and pressures; refer to the above diagrams.

LS load sensing control function

Refer to corresponding hydraulic schematic below.

A selected 'opening' of the directional control valve spool corresponds to a certain flow to the work function. This flow, in turn, creates a pressure differential over the spool and, consequently, also a Δp between the pump outlet and the LS port.

When the differential pressure decreases (e.g. the directional valve is 'opened' further) the Δp also decreases and the LS valve spool moves to the left. The pressure to the setting pistons then decreases and the pump displacement increases.

The increase in pump displacement stops when the Δp finally reaches the setting (e.g. 25 bar) and the forces acting on the valve spool are equal.

If there is no LS signal pressure (e.g. when the directional valve is in the neutral, no-flow position) the pump only delivers sufficient flow to maintain the standby pressure as determined by the Δp setting.

Hydraulic schematic for VP1-45/-060/-075

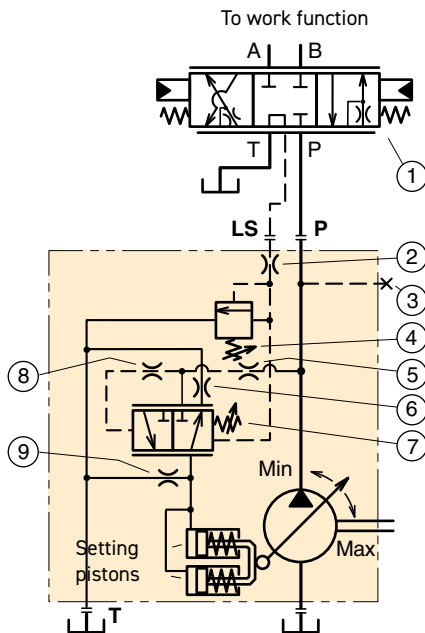

1. Directional, load sensing control valve
2. Load signal orifice (1.0 mm; fixed)
3. Gauge port
4. Signal pressure limiter adjustment
5. System pressure dampening nozzle (2.0 mm)
6. Return line nozzle (0.6 mm)
7. Standby (Δp) pressure adjustment
8. System pressure dampening orifice (fixed)
9. Bleed-off nozzle (0.6 mm).

LS control adjustments

Pressure limiter

Pump size	Factory setting [bar]	Max pressure intermittent [bar]
VP1-045/060/075	350	400
VP1-095/110/130	350	420

LS load sensing valve

Pump size	Factory setting [bar]	Min pressure [bar]	Max pressure [bar]
VP1-045/060/075	25	20	35
VP1-095/110/130	25	15	40

The factory setting, and the standard orifice sizes shown in the corresponding schematic below, will usually provide an acceptable directional valve characteristic as well as system stability.

For additional information, contact Parker Hannifin.

Hydraulic schematic for VP1-095/-110/-130

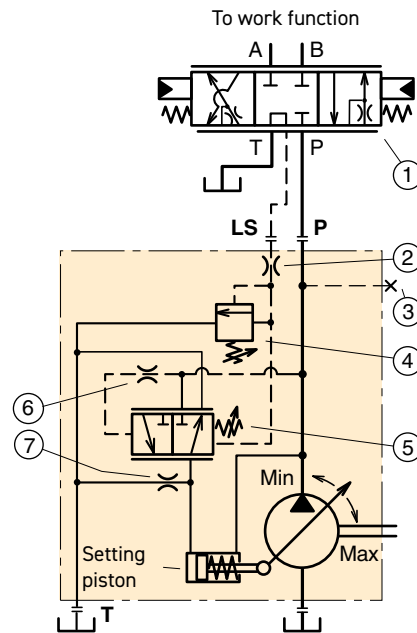

1. Directional, load sensing control valve
2. Load signal orifice (1.0 mm)
3. Gauge port
4. Signal pressure limiter adjustment
5. Standby (Δp) pressure adjustment
6. System pressure dampening orifice (fixed)
7. Bleed-off nozzle (1.2 mm)

Specifications

Frame size VP1 with e-reg.-	045	060	075	095	110	130
Displacement [cm ³ /rev]	45	60	75	95	110	128
Max operating pressure [bar]	350					
Max Speed unloaded [rpm]	3000					
Control type	EPC					
Shaft end spline	DIN 5462					
Mounting flange	ISO 7653-1985					
Weight (with control) [kg]	27					

Electric Proportional Control

The VP1 with e-regulator provides the hydraulic system with the correct amount of fluid at precisely the right moment, effectively reducing energy consumption and heat generation. This means a smoother and fuel saving hydraulic system with reduced CO2 emissions.

The VP1 with e-regulator is designed for electrical pressure control regulator. It is sturdy, yet simple, with few moving parts. The result is a reliable pump with long service life. The factory setting, and the standard orifice sizes shown in the corresponding schematic below, will usually provide an acceptable directional valve characteristic as well as system stability.

For additional information, contact Parker Hannifin.

Hydraulic schematic for VP1-045/-060/-075 EPC1

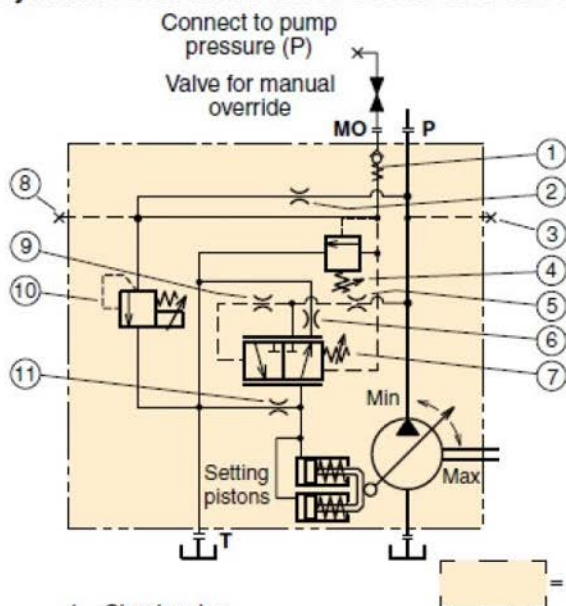

1. Check valve
2. Electric pilot valve orifice
3. Gauge port - pump pressure
4. Signal pressure limiter adjustment
5. System pressure dampening nozzle (2.0 mm)
6. Return line nozzle (0.6 mm)
7. Standby (Δp) pressure adjustment
8. Gauge port - pilot valve
9. System pressure dampening orifice (fixed)
10. Electric pilot valve
11. Bleed-off nozzle (0.6 mm).

Hydraulic schematic for VP1-095/110/130 EPC1

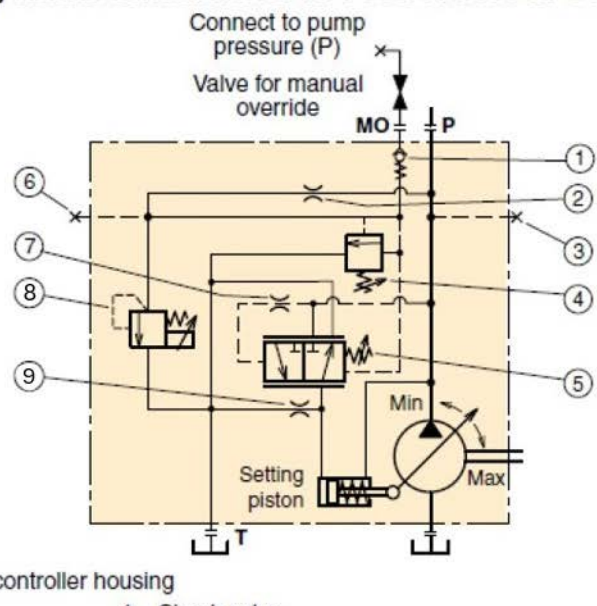

1. Check valve
2. Electric pilot valve orifice
3. Gauge port - pump pressure
4. Signal pressure limiter adjustment
5. Standby (Δp) pressure adjustment
6. Gauge port - LS-pressure
7. System pressure dampening orifice (fixed)
8. Electric pilot valve
9. Bleed-off nozzle (1.2 mm).

Hydraulic schematic for VP1-045/-060/-075 EPC2

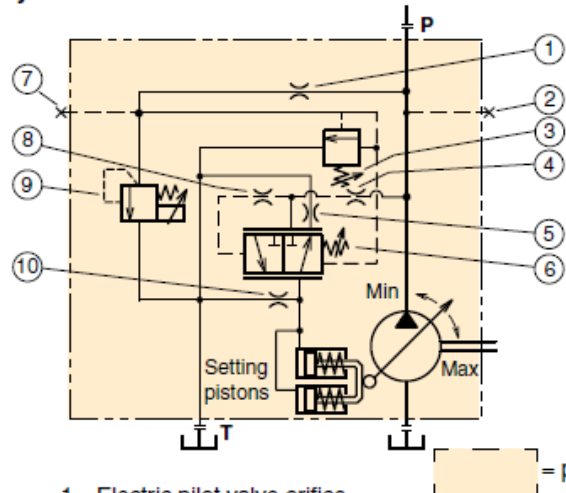

1. Electric pilot valve orifice
2. Gauge port - pump pressure
3. Signal pressure limiter adjustment
4. System pressure dampening nozzle (2.0 mm)
5. Return line nozzle (0.6 mm)
6. Standby (Δp) pressure adjustment
7. Gauge port - LS-pressure
8. System pressure dampening orifice (fixed)
9. Electric pilot valve -negative characteristic
10. Bleed-off nozzle (0.6 mm).

Hydraulic schematic for VP1-095/110/130 EPC2

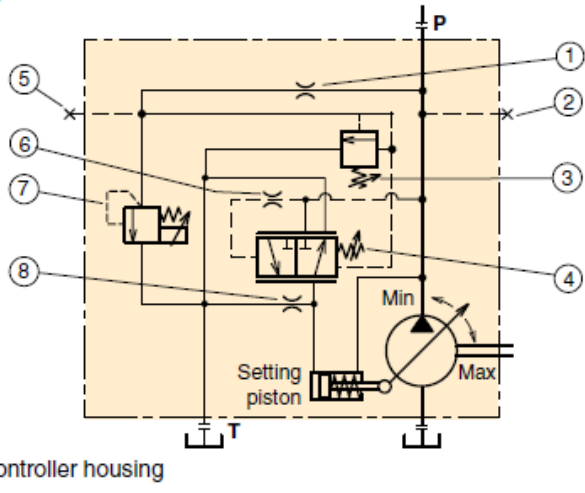

1. Electric pilot valve orifice
2. Gauge port - pump pressure
3. Signal pressure limiter adjustment
4. Standby (Δp) pressure adjustment
5. Gauge port - LS-pressure
6. System pressure dampening orifice (fixed)
7. Electric pilot valve
8. Bleed-off nozzle (1.2 mm).

INSTALLATION DIMENSIONS

Suction fittings for series F1, F2, F3, F4 and T1 pumps also VP1-095, -110 and -130

NOTE: A suction fitting must be ordered separately (not included with the pump). To choose the correct dimension of suction connection, see page 15 ff.

Suctions fittings for VP1-045/075 see page 59.

'Straight' suction fittings for F1, T1, F2, F3, F4, VP1-095/-110/-130

Ordering no.	A mm	B mm	ØC dia. mm (in.)
378 0635 ¹⁾	0	85	38 (1 1/2")
378 0636 ²⁾	17	136	50 (2")
378 0637 ³⁾	25	145	63 (2 1/2")
378 3523 ³⁾	32	174	75 (3")

45° suction fittings for F1, T1, F2, F3, F4 VP1-095/-110/-130

Ordering no.	A mm	B mm	ØC dia. mm (in.)
378 1234 ¹⁾	60	104	32 (1 1/4")
378 0633 ¹⁾	60	104	38 (1 1/2")
378 0364 ²⁾	67	110	50 (2")
378 0634 ³⁾	75	117	63 (2 1/2")
378 3367 ³⁾	95	138	75 (3")
378 1062	67	110	40
378 0975	67	110	45

90° suction fittings for F1, T1, F2, F3, F4 VP1-095/-110/-130

Ordering no.	A mm	B mm	ØC dia. mm (in.)
378 0978 ¹⁾	126	83	38 (1 1/2")
378 0979 ²⁾	135	83	50 (2")
378 1980 ³⁾	147	83	63 (2 1/2")
378 0976	135	83	45
378 8690 ³⁾	185	83	75 (3")

145° suction fitting for F1, T1, F2, F3, F4 VP1-095/-110/-130

Ordering no.	A mm	B mm	ØC dia. mm (in.)
378 1867	165	73	50 (2")

- 1) Recommended for frame size F1-25.
- 2) Recommended for frame size F1-41,-51,-61,-81, -101.
- 3) (3 clamps and 3 screws)

Spare parts

Additional Hold-down-clamp kit consists of:
hold-down-clamp cap screw and O-ring
Ordering no. 378 1321

Additional Hold-down-clamp kit for mounting on BPV
Ordering no. 378 2439

A 'suction fitting' consists of a straight, 45°, 90° or 145° suction fitting, clamps, cap screws and O-ring.

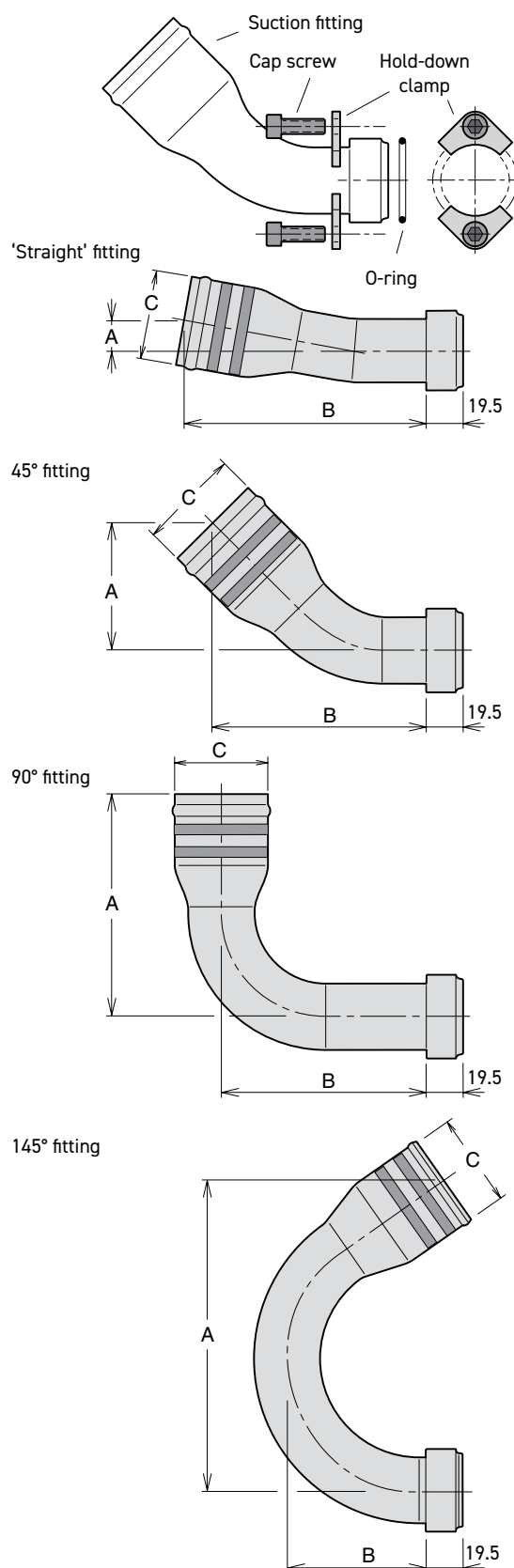

Suitable suction fittings for F1 and VP1-045/-060/-075 with BSP port treads

NOTE: A suction fitting must be ordered separately (not included with the pump). To choose the correct dimension of suction connection, see page 15 ff.

45° suction fittings

Ordering no.	ØA	ØB inch	C mm
00509035016	BSP 1" ¹⁾	2"	18
00509035116	BSP 1 ¼"	2"	18
00509021916	BSP 1 ¼"	2 ½"	18

¹⁾ Not for VP1-045/-060/-075

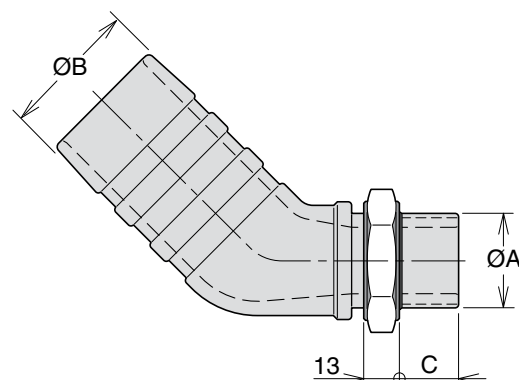

90° suction fittings

Ordering no.	ØA	ØB inch	C mm
00509034516	BSP 1" ¹⁾	2"	18
00509034616	BSP 1 ¼"	2"	18

¹⁾ Not for VP1-045/-060/-075

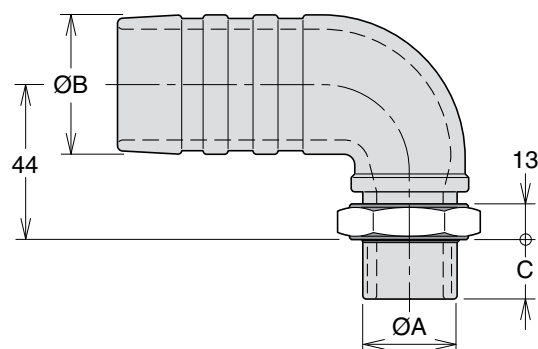

Fitting kits for VP1-045/-060/-075 pumps

Kits with 45° suction fitting

Ordering no.	C ₁	ØC ₂ inch	A mm	B mm
379 9563	BSP ¾"	2"	71	154
379 9562	BSP 1" *	2 ¾"	64	147

* Above 100 l/min

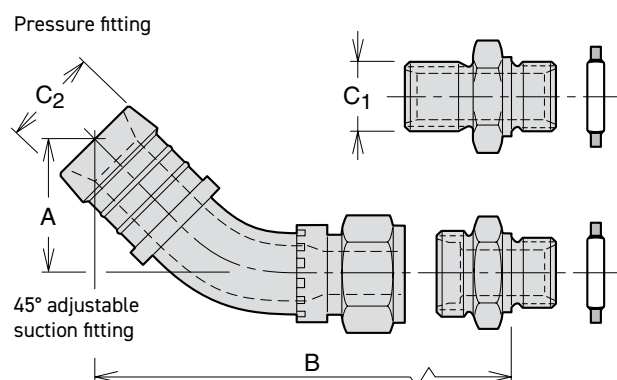

CONTENTS

Auxiliary Valves

Bypass Valves and Unloading Valves for F1, F2, F3, F4, T1 and VP1 pumps

Contents	Page
BPV-F1 and BPV-T1 bypass valve.....	74
Technical Information.....	74
Ordering information and Drawings	75
BPV-F1 and BPV-T1 Bypass valve without manual override ...	75
BPV-F1 and BPV-T1 Bypass valve with manual override	75
BPV-F2 bypass valve	76
Ordering information and Drawings	77
BPV-F2 Bypass valve without manual override.....	77
BPV-F2 Bypass valve with manual override	78
BPV-F1, -T1, -F2, -F3 and -F4 Accessories / Spare Parts	79
BPV-L line mounted bypass valve	80
BPV-VP1 unloading valve.....	81

TECHNICAL INFORMATION

Auxiliary Valves

BPV-F1 and BPV-T1 bypass valve

- The bypass valve is mainly utilised in applications where the F1 pump is driven from the crank-shaft through a cardan shaft, or when it is installed on an engine PTO.
- The BPV bypass valve should be disengaged during transportation when the pump is operating constantly and the engine is running at max rpm; the hydraulic system is not sized for the large flow that would otherwise go through it.
- The BPV valve substantially reduces the energy loss during transportation.
- The valve installs directly on top of the pump end cap with a pressure port 'banjo' fitting and an inlet port spacer bushing with two cap screws; refer to the illustration to the right.
- As the BPV valve is symmetrical, it can be 'turned 180°' to prevent interference with chassis components; it can be utilised for either left hand or right hand pumps.
- The valve function must only be activated or released (by means of the 24 VDC solenoid) at no-load (below 20 bar) system pressure.

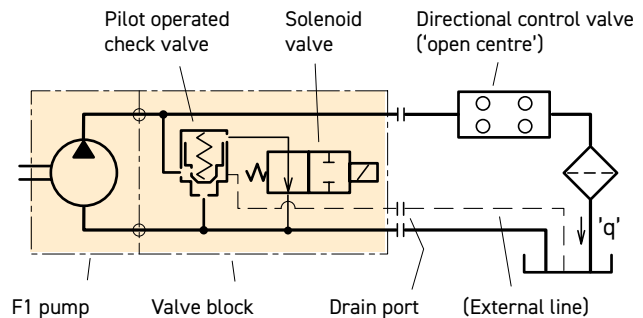

Bypass valve schematic.

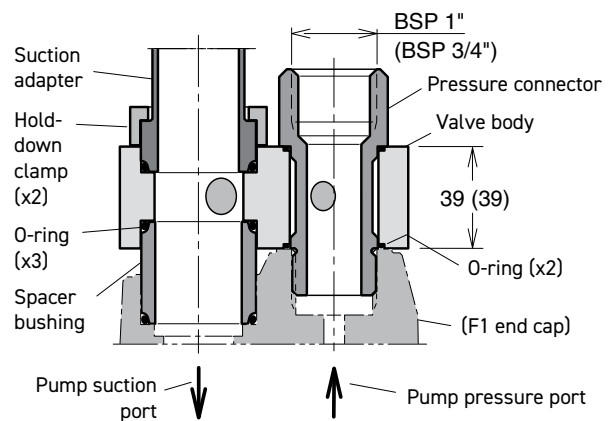

IMPORTANT INFORMATION

- In order to secure a cooling flow through the system, a separate drain line must be connected from the BPV-F1 drain line fitting directly to tank; (shown in the Installation Information Bulletin MSG30-8227-INST/UK/DE) refer also to the schematic.
- The pressure connector must be tightened (to 50 Nm) before the suction fitting clamp screws are tightened.

ORDERING INFORMATION AND DRAWINGS

BPV-F1 and BPV-T1 Bypass valve

Without manual override

Bypass valve, type	BPV-F1-25 to -101 and BPV-T1-81 and -121
Max pressure, continuous	350 bar
intermittent	400 bar
Solenoid voltage (option)	24 VDC, (12 VDC)
Power requirement	14 W
Operating mode	Activated solenoid: Check valve closed

Bypass valve	Voltage	Ordering number	For F1 and T1 size	Torque ¹⁾
BPV-F1, BPV-T1	24 VDC	378 7201	F1-25 ²⁾ , -41, -51, -61 and T1-81	50 Nm
	12 VDC	378 7202		
BPV-F1, BPV-T1	24 VDC	378 7203	F1-81, -101 and T1-121	100 Nm
	12 VDC	378 7204		
Drain fitting kit ²⁾ F1-025		378 1640	Contains a drain line fitting a bonded seal and nozzle.	
Drain fitting kit other F1, T1 and F2		378 3039	Contains a drain line fitting and a bonded seal. N.B. Included in the complete bypass valve.	

1) Torque pressure connector to:

2) Drain fitting kit 378 1640 must be ordered separately for F1-025.

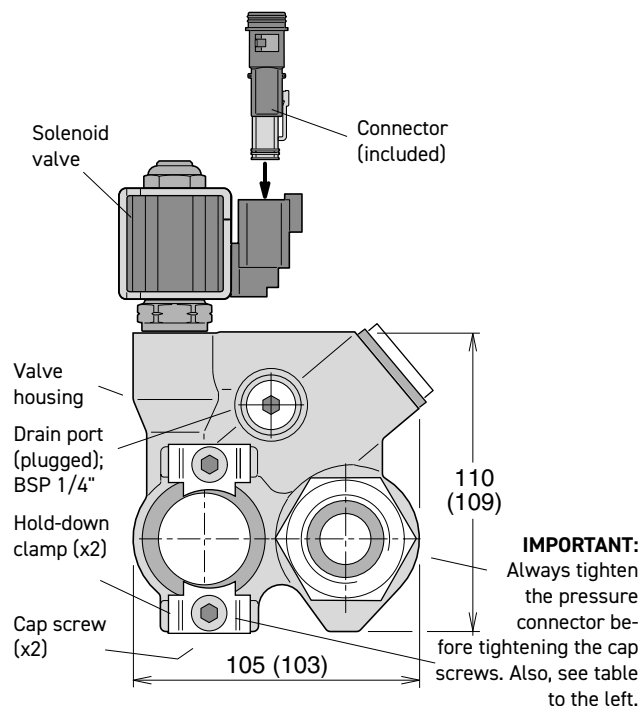

NOTE: Dimensions are shown for BPV-F1-81 (those for BPV-F1-25 are in parenthesis)

BPV-F1 and -T1 installation and cross section without manual override

BPV-F1 and BPV-T1 Bypass valve

With manual override

Bypass valve, type	BPV-F1-25 to -101 and BPV-T1-81 and -121
Max pressure, continuous	350 bar
intermittent	400 bar
Solenoid voltage	24 VDC
Power requirement	14 W
Operating mode	Activated solenoid: Check valve closed

Bypass valve	Voltage	Ordering number	For F1 and T1 size	Torque ¹⁾
BPV-F1, BPV-T1	24 VDC	378 04179	F1-25 ²⁾ , -41, -51, -61 and T1-81	50 Nm
	24 VDC	37804180		
Drain fitting kit ²⁾ F1-025		378 1640	Contains a drain line fitting a bonded seal and nozzle.	
Drain fitting kit other F1, T1 and F2		378 3039	Contains a drain line fitting and a bonded seal. N.B. Included in the complete bypass valve.	

1) Torque pressure connector to:

2) Drain fitting kit 378 1640 must be ordered separately for F1-025.

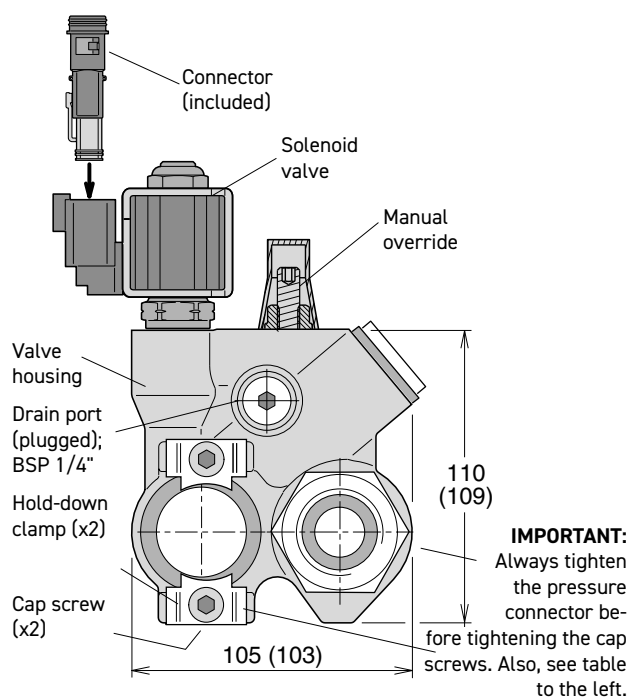

NOTE: Dimensions are shown for BPV-F1-81 (those for BPV-F1-25 are in parenthesis)

BPV-F1 installation and cross section with manual override

TECHNICAL INFORMATION

BPV-F2 bypass valve

- An F2 twin pump fitted with a bypass valve can be utilised in applications where the pump is operating constantly i.e. when the pump is driven from the crankshaft through a cardan shaft, or when it is installed on an engine-PTO. In addition, it can be used when, temporarily, one of the two circuits is not required; the power loss is thus reduced as the non-required flow is not forced through lines and 'open center' valves.
- The BPV bypass valve should be disengaged during transportation when the pump is operating constantly and the engine is running at max rpm; the hydraulic system is not sized for the large flow that would otherwise go through it.
- The BPV valve connects the outlet and inlet ports of the pump, and only a small oil flow goes through the system and to the reservoir.
- The valve is installed directly on top of the pump port surface with 'banjo' fittings and two cap screws (refer to the split view to the right).
- As the BPV valve is symmetrical it can be 'turned 180°' so as not to interfere with chassis components. The valve can accommodate left hand as well as right hand rotating pumps.
- The valve can only be engaged or disengaged (through the 24 or 12 VDC solenoid) at low system pressures (below 20 bar).

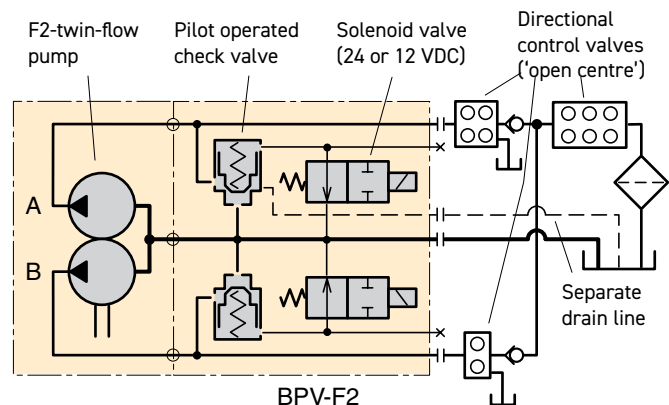

Bypass valve circuit schematic (example).

IMPORTANT INFORMATION

- In order to secure a cooling flow through the system, a separate drain line must be connected from the BPV-F2 drain line fitting (shown in the split view) directly to tank; refer also to the schematic.
- The pressure connectors must be tightened (to 50 Nm) before the suction fitting clamp screws are tightened.

ORDERING INFORMATION AND DRAWINGS

BPV-F2 Bypass valve

Without manual override

Bypass valve, type	BPV-F2
Max pressure, continuous	350 bar
intermittent	400 bar
Solenoid voltage (option)	24 VDC, (12 VDC)
Power requirement	14 W (each solenoid)
Operating mode	Activated solenoid: Check valve closed

Bypass valve ¹⁾	Voltage	Ordering number	For F2 size	Torque ³⁾
BPV-F2,	24 VDC 12 VDC	378 7424 378 7425	All Sizes	50 Nm

1) The BPV-F2 valve kit contains parts designated '1' in the split view to the right.

2) A suction fitting kit (parts designated '2' in the split view) is not included with the F2 pump; it must be ordered separately (refer to page 72).

3) Torque pressure connector to:

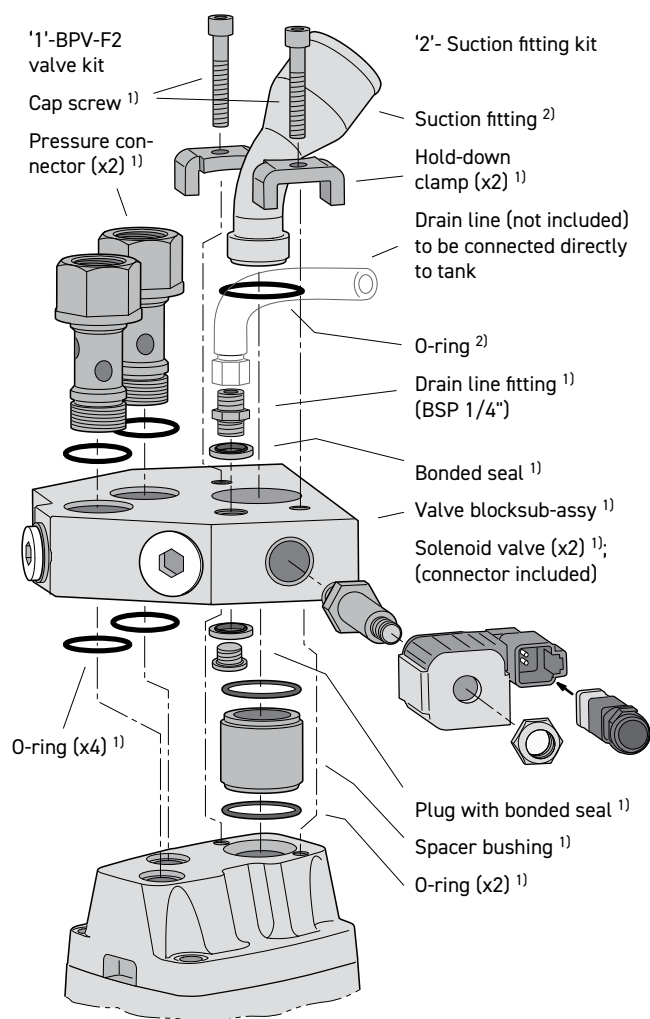

Bypass valve split view without manual override (with F2 end cap).

NOTE: A suction fitting kit (parts designated '2' in the split view) is not included with the F2 pump; it must be ordered separately (refer to cpage 72ff).

BPV-F2 Bypass valve

With manual override

Bypass valve, type	BPV-F2
Max pressure, continuous	350 bar
intermittent	400 bar
Solenoid voltage (option)	24 VDC
Power requirement	14 W (each solenoid)
Operating mode	Activated solenoid: Check valve closed

Bypass valve ¹⁾	Voltage	Ordering number	For F2 size	Torque ³⁾
BPV-F2,	24 VDC	378 4377	All Sizes	50 Nm

- 1) The BPV-F2 valve kit contains parts designated '1' in the split view to the right.
- 2) A suction fitting kit (parts designated '2' in the split view) is not included with the F2 pump; it must be ordered separately (refer to page 72).
- 3) Torque pressure connector to:

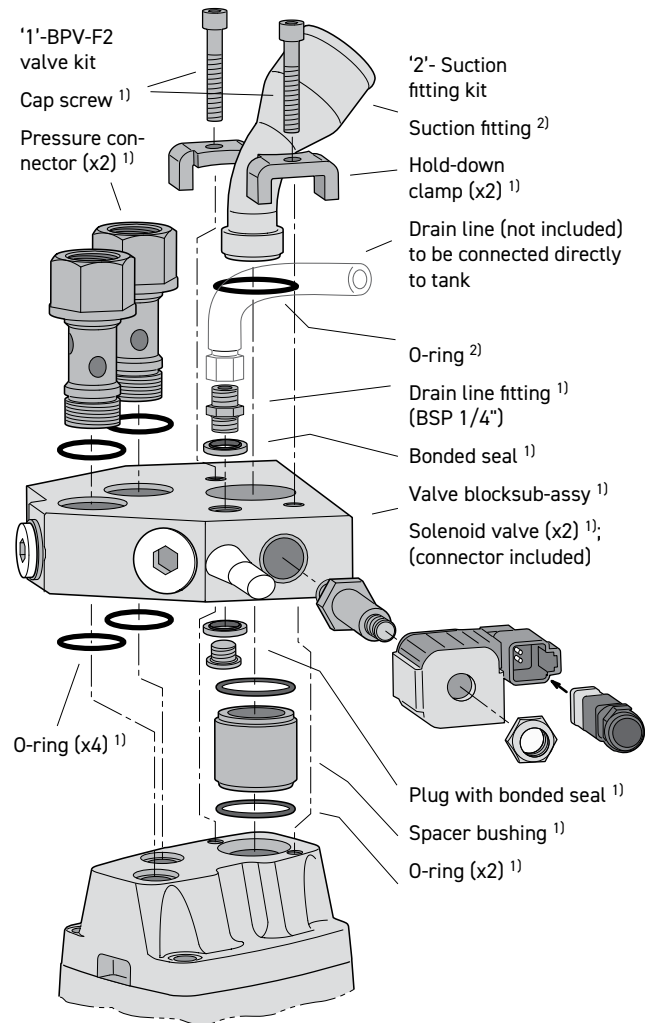
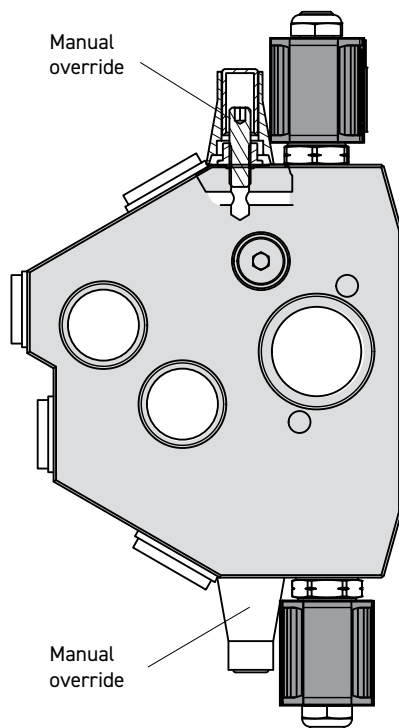

Bypass valve split view with manual override (with F2 end cap).

NOTE: A suction fitting kit (parts designated '2' in the split view) is not included with the F2 pump; it must be ordered separately (refer to page 59 ff).

TECHNICAL INFORMATION

BPV-F1, -T1, -F2, -F3 and -F4 Accessories / Spare Parts

Part No	Description	Remarks
3787496	Solenoid 24 V	Incl. new connector
3787497	Solenoid 12 V	Incl. new connector
3787494	Cartridge valve assy 24 V	Incl. new connector
3787495	Cartridge valve assy 12 V	Incl. new connector
3785948	Nut for cartridge valve	
3787488	Male contact kit	

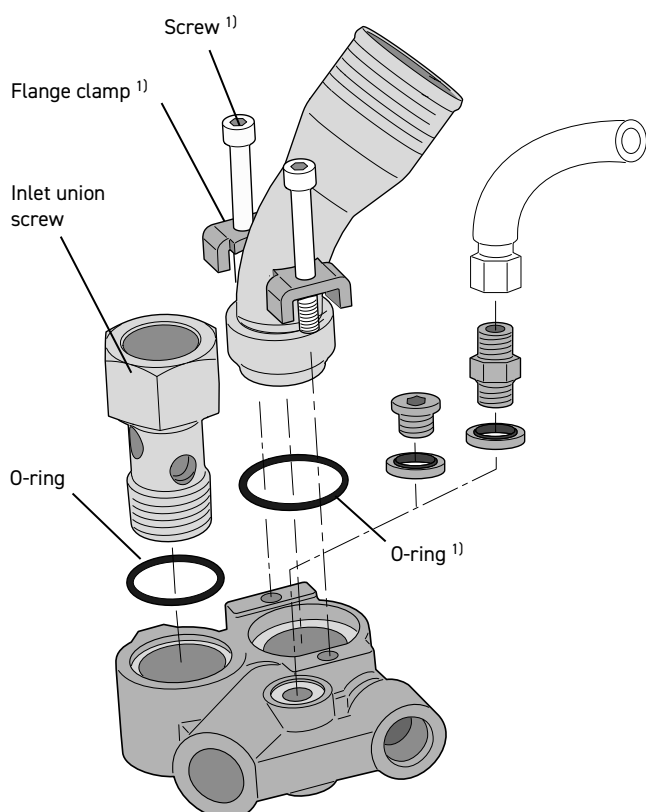
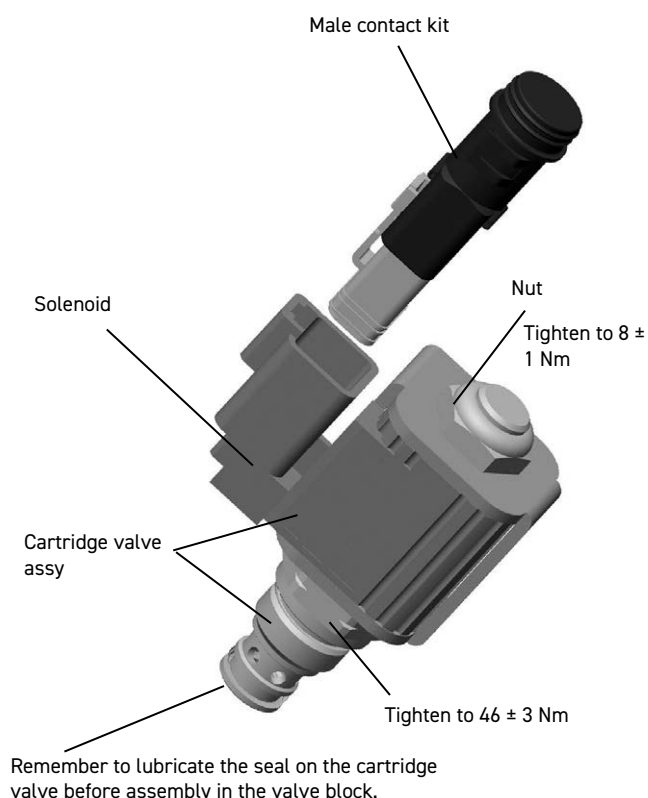

Part No	Description	Remarks
3781480	Inlet union screw	F2 (all sizes)
3781082	Inlet union screw	F1-25, -41, -51, -61 and T1-81
3781094	Inlet union screw	F1-81, -101, T1-121, and F3-81, -101
3780641	O-ring kit	For F1, T1, F2, F3 and F4 (all sizes)
3782439	Hold-down clamp Suction fitting ¹⁾	For BPV F1, T1, F2, F3 and F4

¹⁾ Hold-down clamp for suction fitting on bypass valve for F1, T1, F2 and F3 (parts designated '1' in the split view).

BPV-L line mounted bypass valve

- The unloading valve BPV-L is utilised in hydraulic systems where the fixed displacement pump is engaged constantly and no flow is required, i.e. during transportation. The flow is directed through the unloading valve which has a low pressure loss and less heat is being generated in the system.
- When the solenoid is activated the unloading valve closes and the pump flow is directed to the directional control valve or other user.

Unloading valve, type	BPV-L
Max operating pressure [bar]	350
Max flow [l/min]	250
Solenoid voltage [VDC]	24
Required power [W]	14
Operating mode	Activated solenoid: Check valve closed
Ordering number	378 1487

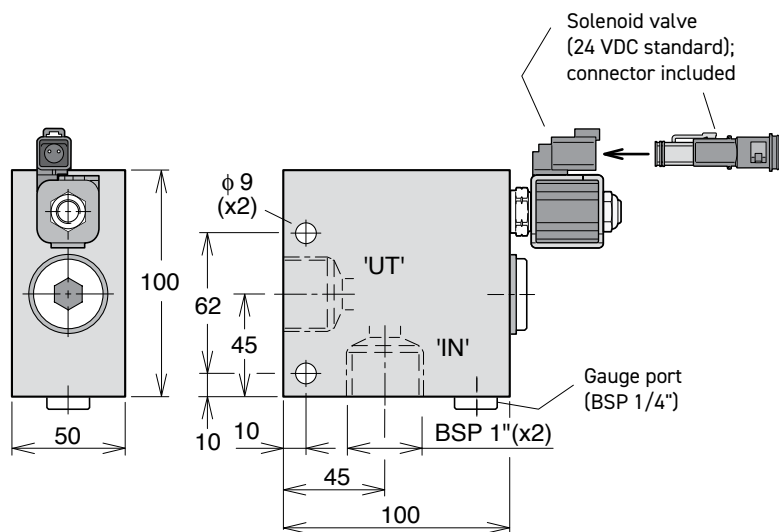
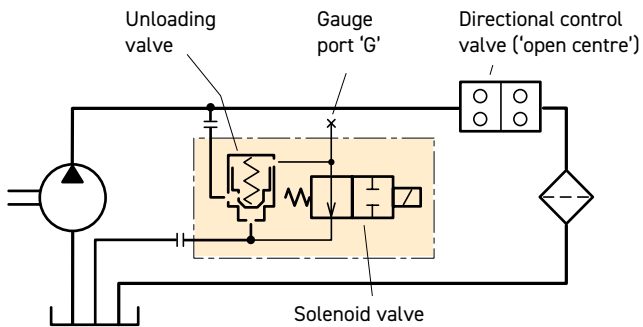

VP1 installation on an engine PTO

BPV-VP1 unloading valve

The BPV-VP1 unloading valve is utilized in hydraulic systems where the pump is in constant operation.

- The valve protects the pump from being overheated in the off-load mode by allowing a small flow through the pump. When load sensing valve function is engaged, the bypass flow is cut off (as port 'X' is being pressurized).
- The valve will also de-air the suction line and the pump body after a long standstill.
- (The pump is assembled above the oil-tank and during the standstill some of the oil in the pump housing has been drained back to the oil-tank)

Valve type	Ordering number
BPV-VP1	379 8799

NOTE: - BPV-VP1 with VP1-045, -060 or -075 and
- BPV-VP1 with VP1-095, -110 or -130,
see next page.

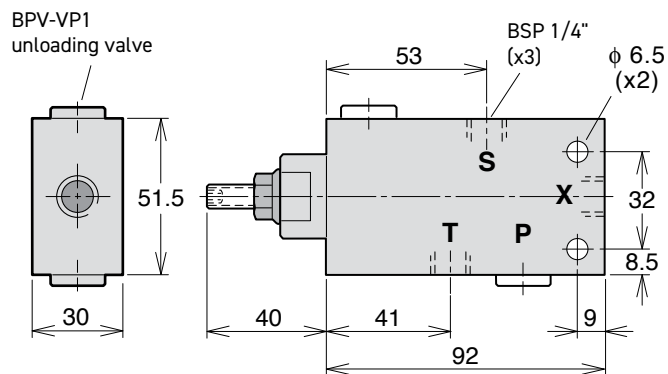

BPV-VP1 unloading valve.

For more information also see MSG30-8226-INST/UK, Installation Information Unloading Valve BPV for VP1

BVP-VP1 with VP1-045/-060/-075 pumps

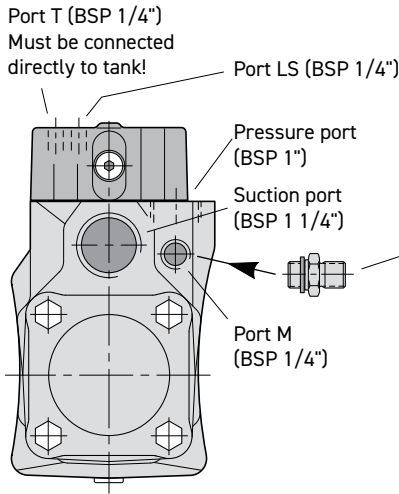

NOTE:

- Install the fitting (included) in port M and connect it, in turn, to port S of the unloading valve (see schematic).
- An orifice is included in the fitting. Connection on the fitting is 1/4" BSP threads. Size of orifice in the fitting is \varnothing 1.5 mm.

VP1-045/-060/-075 end view (showing ports).

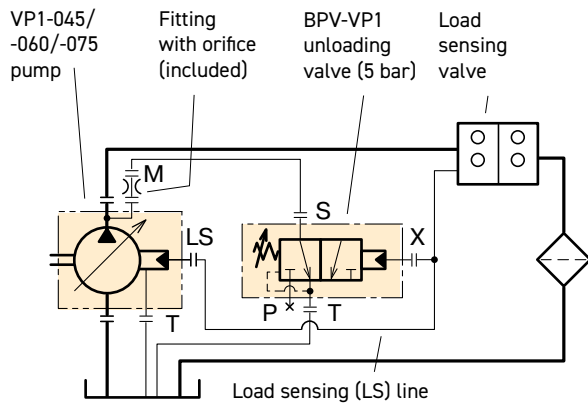

BPV-VP1 installation schematic with VP1-045/-060/-075 pump.

BPV-VP1 with VP1-095/-110/-130 pumps

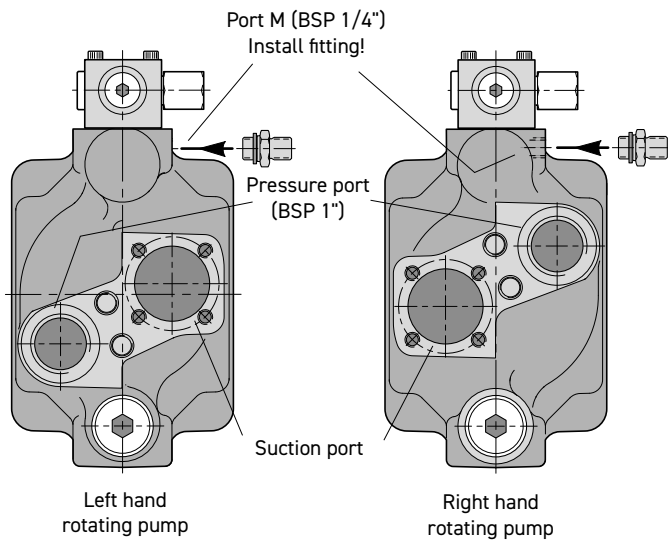

VP1-095/-110/-130 main ports (with fitting installation).

NOTE:

- Install the fitting (included) in port M and connect it, in turn, to port S of the unloading valve (see schematic).
- An orifice is included in the fitting. Connection on the fitting is 1/4" BSP threads. Size of orifice in the fitting is \varnothing 1.5 mm.

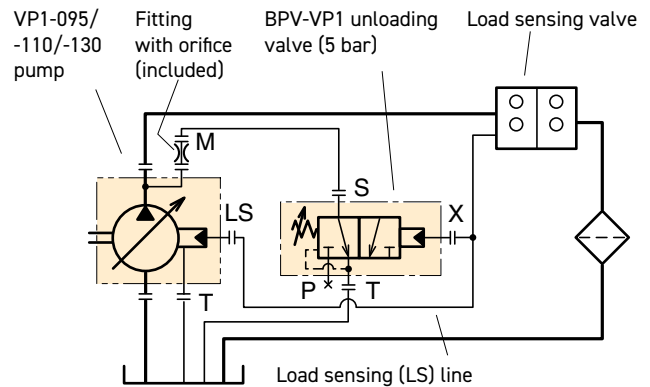

BPV-VP1 installation schematic with VP1-095/-110/-130 pump.

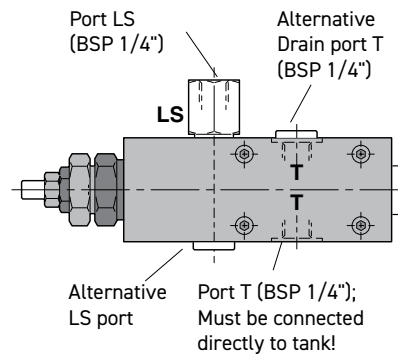

VP1-095/-110/-130 control valve ports.

CONTENTS

Accessories

Contents	Page
PTO Adapter Kits:	
PTO adapter kit for Scania ED 120 and 160 engine - PTO	84
PTO adapter kit for Mercedes engines (R6)	85
PTO adapter kit for Mercedes engines (V6, V8)	85
PTO adapter kit for MAN (D20, D26)	85
Pump couplings and mounting brackets	86
PTO flange adapters	86
Pump couplings	87

TECHNICAL INFORMATION

PTO adapter kit for Scania ED 120 and 160 engine - PTO

- With the adapter kit, a hydraulic pump (e.g. F1 or VP1) that meets the ISO standard can be installed on the PTO of the Scania engine.
- The PTO gear is supplied with the chassis.
- **Please note:** The engine must be ordered with a PTO.

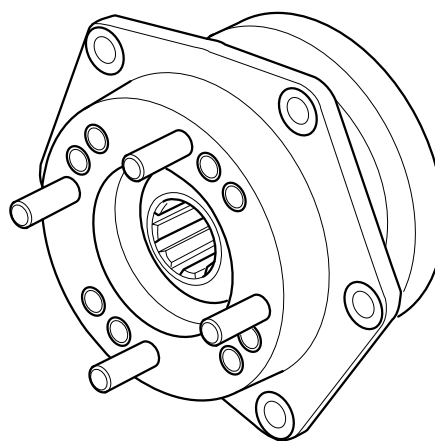
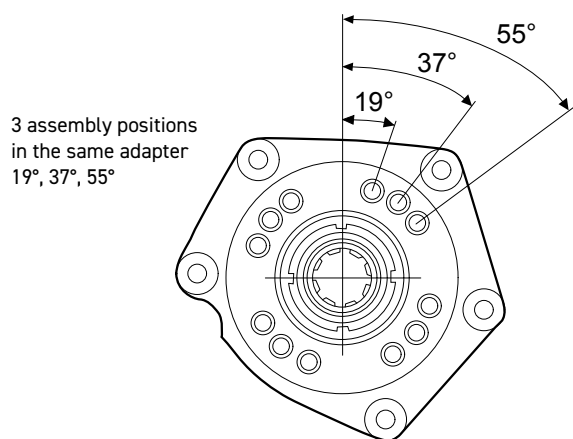

ED 120

Technical Information	
Max. torque [Nm]	600
Gear ratio (engine:pump)	1 : 1.19
Pump rotation	Right hand (clockwise)
PTO adapter kit	Ordering number
ED120, bearing supported 19°, 37°, 55°	378 9592

ED 160

Technical Information	
Max. torque [Nm]	600
Gear ratio (engine:pump)	1 : 1.19
Pump rotation	Left hand (counter clockwise)
PTO adapter kit	Ordering number
ED-160, bearing supported 19°, 37°, 55°	378 9970

PTO adapter kit for Mercedes engines (R6)

With the adapter kit, a hydraulic pump that meets the ISO standard can be installed on the PTO of the Mercedes R6 engines.

Torque continuous	300 Nm
Torque intermittent	330 Nm
Gear ratio (engine to pump)	1 : 1.071
Pump rotation	Right hand
Ordering No.	0050706404

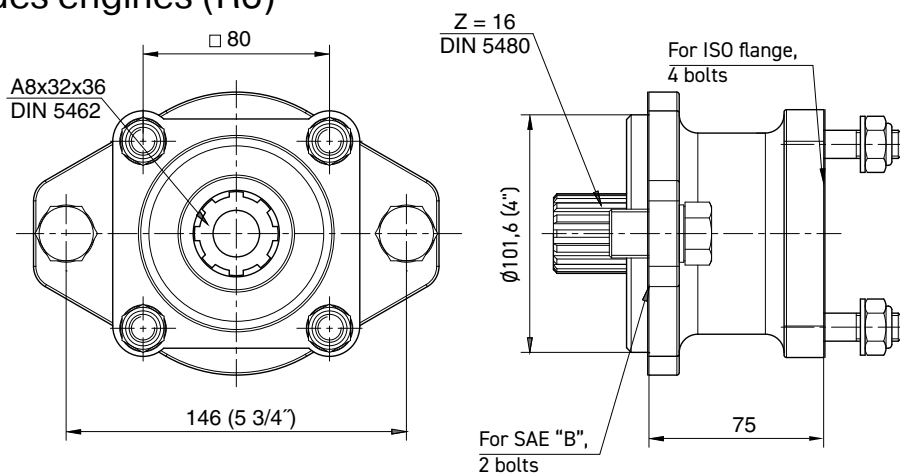

PTO adapter kit for Mercedes engines (V6, V8)

With the adapter kit, a hydraulic pump that meets the ISO standard can be installed on the PTO of the Mercedes V6 and V8 engines.

This adapter (7012104), can be fitted on the original DC SAE-A adapter, delivered together with the new ACTROS from DC factory.

Torque continuous	390 Nm
Torque intermittent	470 Nm
Gear ratio (engine to pump)	1 : 1.15
Pump rotation	Right hand
Ordering No.	00507012104

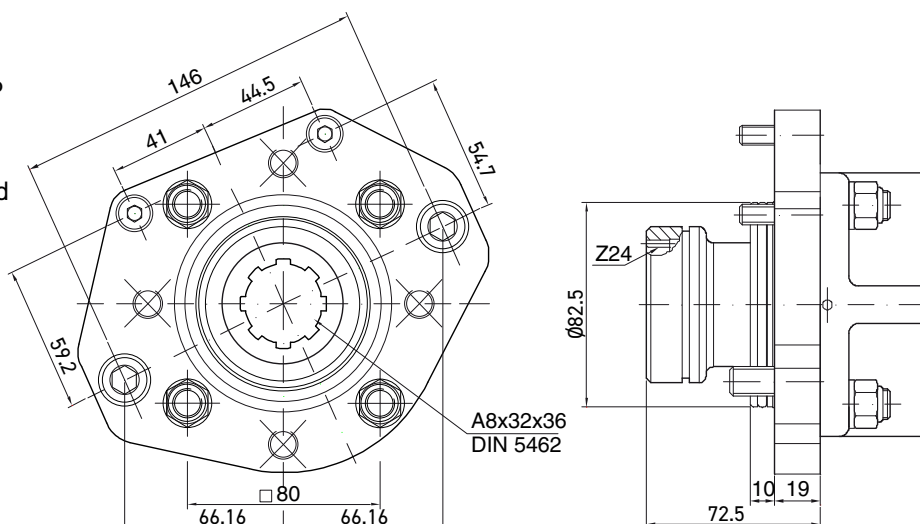

PTO adapter kit for MAN (D20, D26)

With the adapter kit, a hydraulic pump that meets the ISO standard can be installed on the PTO of the MAN D20 engines.

PTO adapter	D20, D26
Torque continuous	400 Nm
Torque intermittent	570 Nm
Gear ratio (engine to pump)	1 : 1.233
Pump rotation	Right hand

PTO adapter	Ordering No.
D20, D26	0050081903

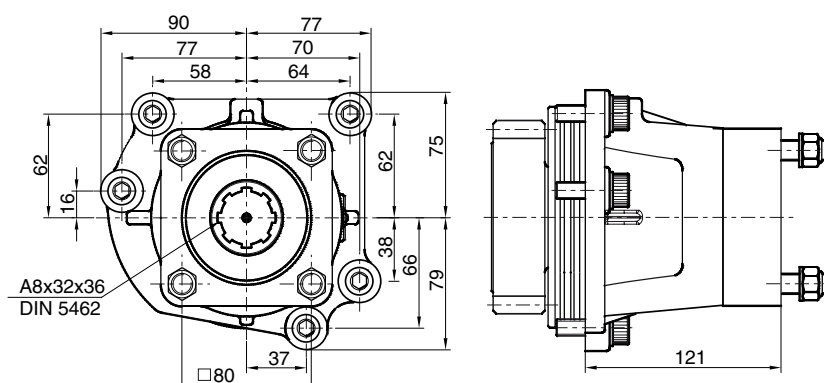

Pump couplings

Designation	DIN 90 (fig. 1)
A	90
B	74.5
C	47 h7
D	M8
E ₁	61.5
E ₂ (F1)	57.2
VP1, F2, F1*	370 4634
F1	378 0642

NOTE: Max torque is limited by the cardan shaft.

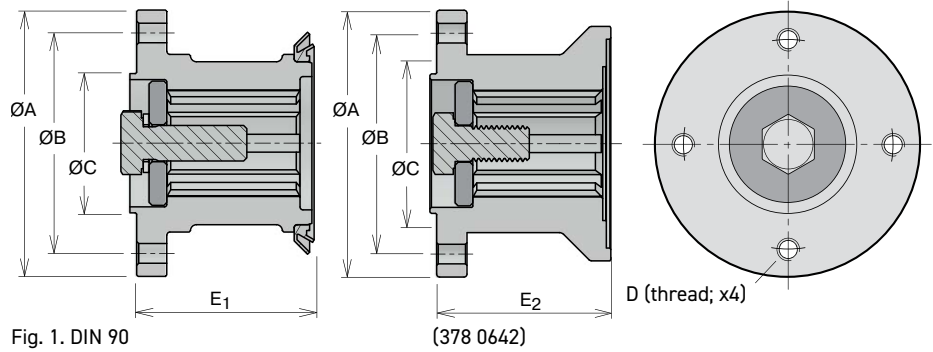

Fig. 1. DIN 90

Designation	DIN 90 (fig. 1)
A	90
B	74.5
C	47 h7
D	8.2
E ₁	61.5
VP1, F2, F1*	370 7423

NOTE: Max torque is limited by the cardan shaft.

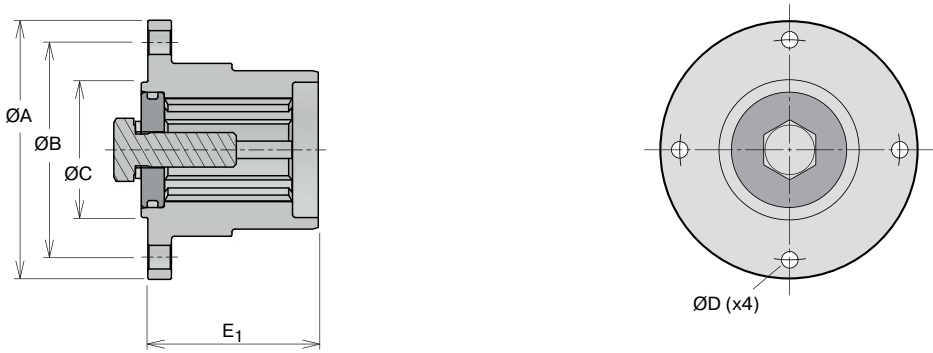

Fig. 2. DIN 90 (370 7423)

Designation	SAE88 (fig. 3)
A	88
B	69.9
C	57.15 H8
D	5/16" UNC
E ₁	59.5
Max torque [Nm] interm./contin.	600/ 300
F1	378 0644



Fig. 3. SAE 88 (378 0644)

Designation	SAE97 (fig. 4)
A	97
B	79.4
C	60.33 H8
D	3/8" UNC
E ₁	65
E ₂ (F1)	59.5
Max torque [Nm] interm./contin.	1000/500
VP1, F2, F1*	370 4631
F1	378 0645

F1* Old versions

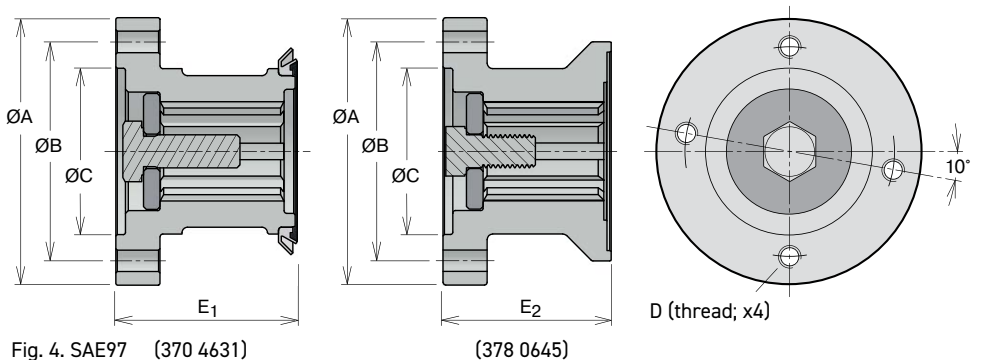

Fig. 4. SAE97 (370 4631)

INSTALLATION AND START UP

Installing couplings, sleeves, and gears on the pump shaft.

This is a short installation and start up information. To have the complete and latest installation information, always see the installation info supplied together with the pump.

PTO installation

- 'Left hand' and 'Right hand' rotation defined in the illustrations on page 77.
- The driving gear of the PTO and the driven gear of the pump are shown in the illustration below. (A right hand rotating pump is shown).

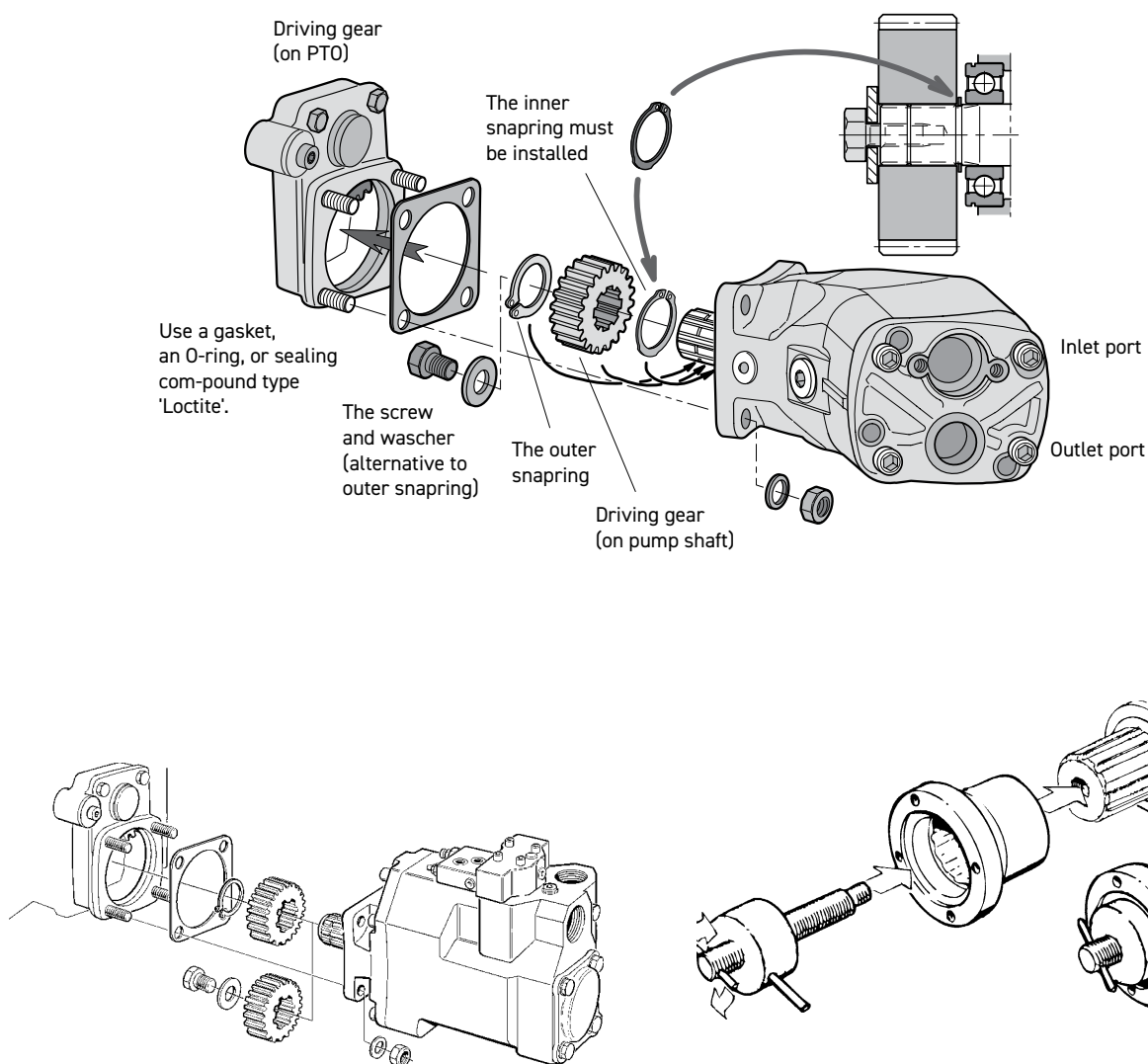

IMPORTANT

Use some kind of special tool when you install couplings, sleeves, and gears on the pump shaft. Force must never be used when installing these parts on the F1 shaft.

INSTALLATION AND START UP

GPA and GP1

1) Flow vs. shaft rotation

- The gear pumps are bi-directional (and internally drained)
- Port connector assembly:
 - Screw in the connector until it firmly touches the pump housing; then tighten the connector 30° (1/12 turn).

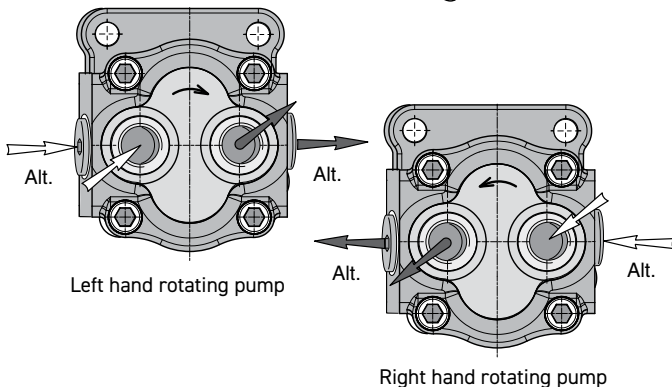
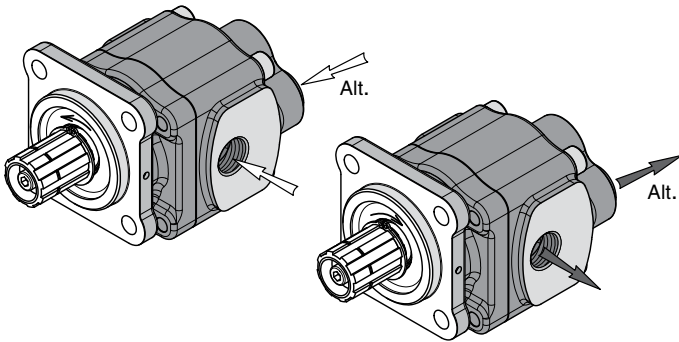
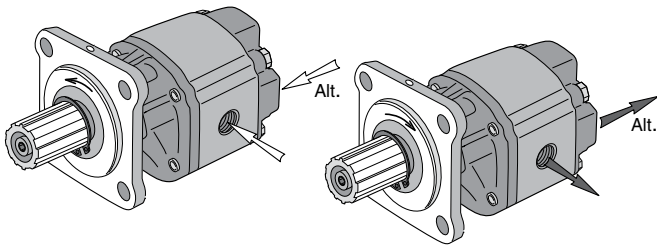

2) Suction fitting selection

Flow speed [m/s] at indicated line size [mm/in]

[l/min]	19/3/4"	25/1"	32/1 1/4"	38/1 1/2"	50/2"
5	0.3	0.2	0.1	< 0.1	< 0.1
15	0.9	0.5	0.3	0.2	0.1
25	1.5	0.8	0.5	0.4	0.2
40	-	1.4	0.8	0.6	0.3
60	-	2.0	1.2	0.9	0.5
80	-	-	1.7	1.2	0.7
100	-	-	-	1.5	0.8

The gearpump must not be installed more than 0.5 m above the min. oil level in the reservoir.

3) Lubricate the spline

When the PTO has a sealed-off output sleeve (as shown in the illustration), the gearpump shaft spline must be lubricated with a heat-resistant grease before start-up; repeat periodically (at least once a year).

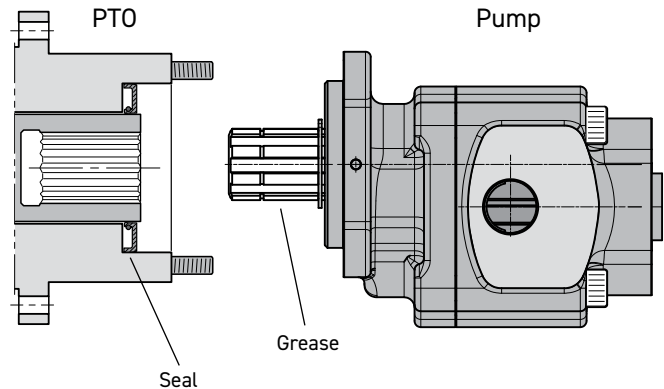

4) No external shaft loads

- No external radial or axial shaft loads are allowed on the pump shaft.
- In case of radial and/or axial shaft loads an external, bearing supported coupling must be utilized.

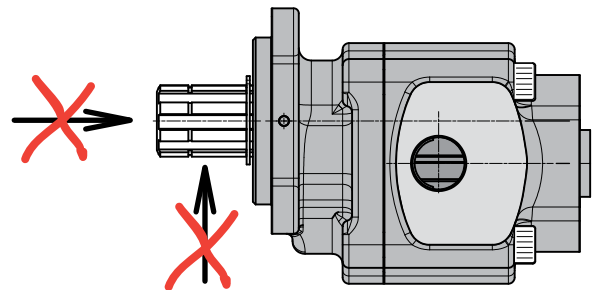

5) Hydraulic fluid

Use, exclusively, good quality hydraulic fluid with anti-foam and anti-wear additives. The fluid must meet the following specifications: DIN 51 524 / 51 525 (type HLP).

Viscosity

Acceptable:

- 8 - 1000 cSt (mm²/s)

Recommended:

- 22 cSt (in cold climate)
- 37 cSt (in temperate climate)
- 46 cSt (in hot climate)

Temperature

- Min. - 15 °C
- Max. + 80 °C

Filtration

- Suction line: Not recommended
- Pressure line: 10 to 25 µm.

INSTALLATION AND START UP

F1, T1, F2, F3 and F4

Installation and start-up for F1, T1, F2, F3 and F4

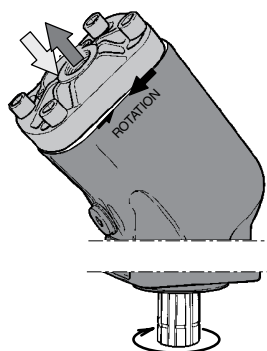

Left hand (L.H.; counter clockwise) rotating pump.

Direction of rotation

The pictures above show direction of flow vs. shaft rotation.

The direction of rotation can be changed (i.e. from right hand to left hand) by turning the end cap.

Remove the four cap screws and turn the end cap about half a turn while making sure it stays in contact with the barrel housing.

Re-fit the cap screws and torque to 80 – 100 Nm.

Installation

Make sure max torque and bending moment (due to the weight of the pump) of the utilised PTO are not exceeded. (The approx. center of gravity of the various pump sizes are shown in the installation drawings).

The top illustration on page 87 shows two ways of installing a gear on the shaft of fixed displacement pumps. The pump shaft spline end usually fits directly in the PTO internal spline coupling.

NOTE: In order to obtain the longest bearing life, the pump should be installed according to the information shown on page 85 "Pump bearing life".

Fluid viscosity

Recommended viscosity:
20 to 30 mm²/s (cSt).

Operating viscosity limits:

- Min 10 mm²/s; max 400 mm²/s.
- At start-up, max 4000 mm²/s.

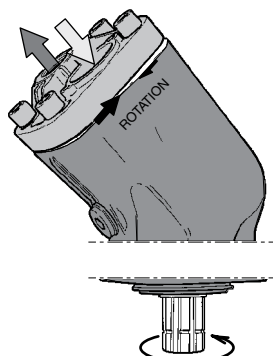

Right hand (R.H.; clockwise) rotating pump.

Fluids

The fixed displacement pumps data shown in the specifications for each pump are valid when operating on high quality, mineral based hydraulic oil.

Type HLP (according to DIN 51524) hydraulic oil is suitable as well as biologically degradable fluids like natural and synthetic esters and polyalphaolefins.

The utilised hydraulic fluid shall meet one of the following Swedish standards:

- SS 15 54 34
- SMR Hydraulic Oil Standard 1996-2.

Contact Parker Hannifin for further information.

NOTE: - ATF (automatic transmission fluid) and API type CD engine oils may also be useable.

- Seals are made of nitrile rubber; make sure the utilised fluid is compatible with this material.

Fluid temperature

Main circuit: Max 75 °C.

Drain line

Fixed displacement pumps don't need an external drain line as they are internally drained.

When the pump is mounted in a Engine-PTO we recommend a drain line from the bypass valve directly to oil tank.

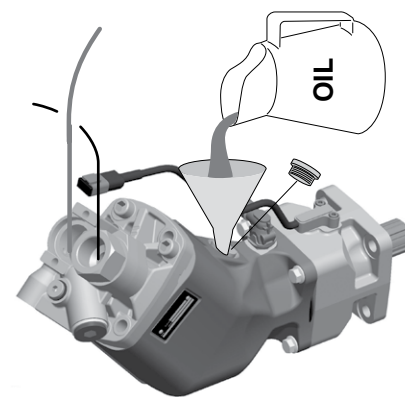

Before start-up, the housing must be filled with hydraulic fluid.

Filtration

Filtration should follow ISO standard 4406, code 20/18/13.

To obtain the longest life of fixed displacement pumps, we recommend an oil cleanliness of 10 µm (absolute).

Start-up

Make sure the entire hydraulic system is clean before filling it with a recommended hydraulic fluid.

In particular, make sure the pump is filled (to at least 50 %) as the internal leakage does not provide sufficient lubrication at start-up.

NOTE: - The suction port should always be above the pressure port when the pump is installed above the reservoir oil level.

- During operation, the pump must be filled with oil to at least 50 %.

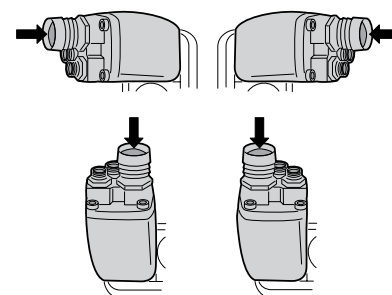

If any oil should drop out of the indication-hole on the pump;

- Stop the system immediately.
- Determine the cause of leakage.
- Replace damaged parts.
- Make sure you have corrected the source of the problem, not only the symptom.

Parker can not be held responsible for damage to PTO, engine and gearbox caused by improper maintenance of the hydraulic system.

F3

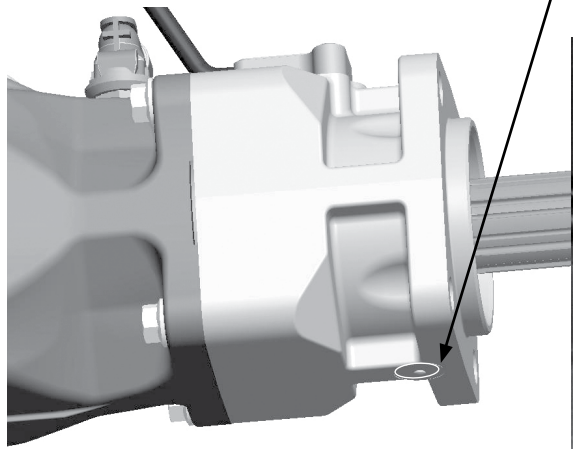

F1

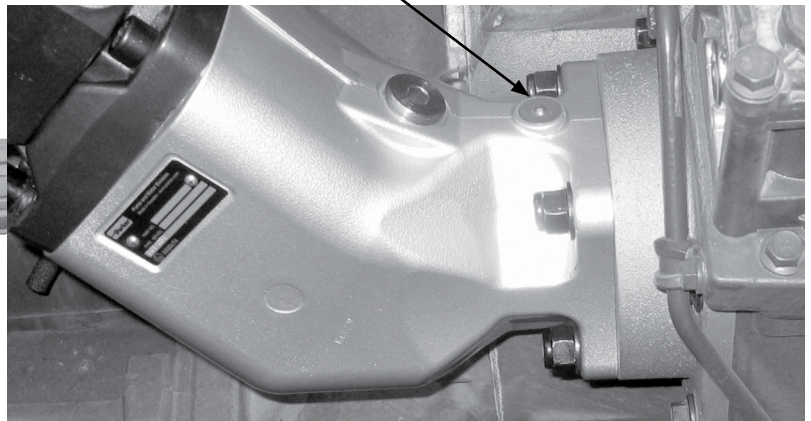

Pump bearing life

Bearing life is dependent on how the pump is installed on the PTO as shown in the illustrations below.

A pump mounted according to fig. 1 gives the lowest bearing life; the highest is obtained when installed according to fig. 3.

Parker Hannifin will assist in determining bearing life in a particular application.

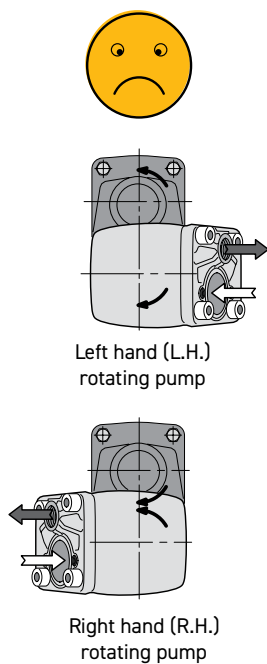

Fig. 1.

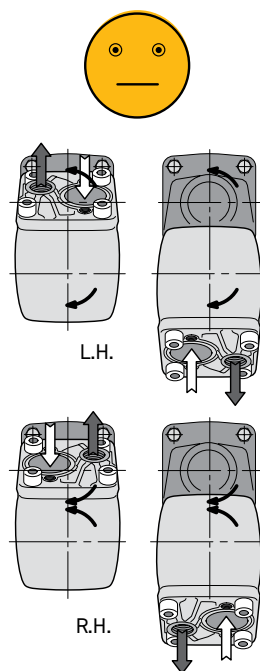

Fig. 2.

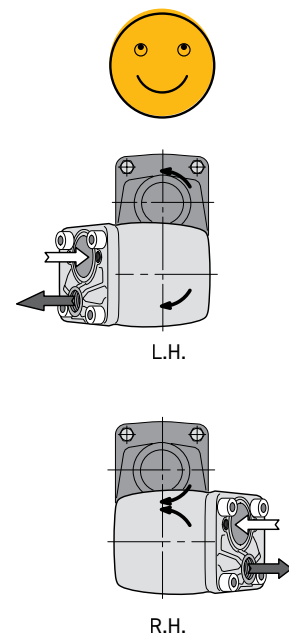

Fig. 3.

INSTALLATION AND START UP

VP1

Installation and start-up for VP1

Direction of rotation

The basic VP1 pump is uni-directional; there is a left hand and a right hand version (indicated by the arrow on the side of the VP1 pump (fig. 4 and 5).

Consequently, the required direction of rotation must be stated when ordering the pump.

Installation

The VP1 can be installed (close-coupled) directly on a PTO (which meets ISO DIN 5462).

Before start-up, the pump must be filled with hydraulic fluid and purged. Utilise the uppermost purge plug (refer to the installation drawing on pages 60 and 61).

Figure 6 (page 80) shows two ways of installing a gear on the VP1 shaft. On a non-gear or a geared PTO with support bearings, the pump shaft is usually installed directly in the internally splined PTO output shaft.

Make sure max torque and bending moment (due to the weight of the pump) of the utilised PTO are not exceeded. (The approx. center of gravity of the various pump sizes are shown in the installation drawings).

Hydraulic fluids

The VP1 data shown in the specifications on page 58, are valid when operating on a high quality, mineral based fluid.

Hydraulic fluids type HLP (DIN 51524), ATF (automatic transmission fluids), and API type CD engine oils are suitable.

Fluid temperature

Main circuit: Max 75 °C.

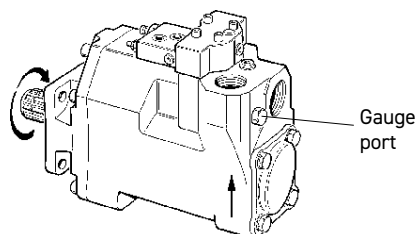

Fig. 4. Left hand rotating pump.

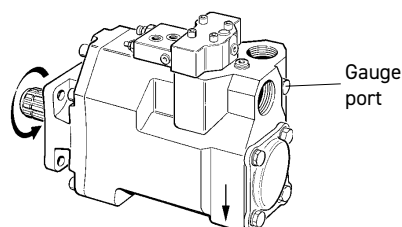

Fig. 5. Right hand rotating pump.

Viscosity

Recommended viscosity: 20 to 30 mm²/s (cSt).

Operating viscosity limits: 10 to 400 mm²/s.

At start-up: Max 1000 mm²/s.

Filtration

To obtain long VP1 life, we recommend a filtration level of:

- 25 µm (absolute) in clean environment or at low pressures.
- 10 µm (absolute) in contaminated environment or at high pressures.

Filtration should meet ISO standard 4406: code 20/18/13.

Drain line

The LS valve requires a separate drain line; it should be routed directly to the reservoir (refer to fig. 8).

Start-up

Make sure the entire hydraulic system is clean before filling it with a recommended fluid.

In addition, the VP1 pump must be purged to remove any entrapped air in the pump housing; utilise the uppermost purge port (fig. 8).

IMPORTANT

As shown in fig. 8, the pump inlet must always be below the lowest reservoir oil level.

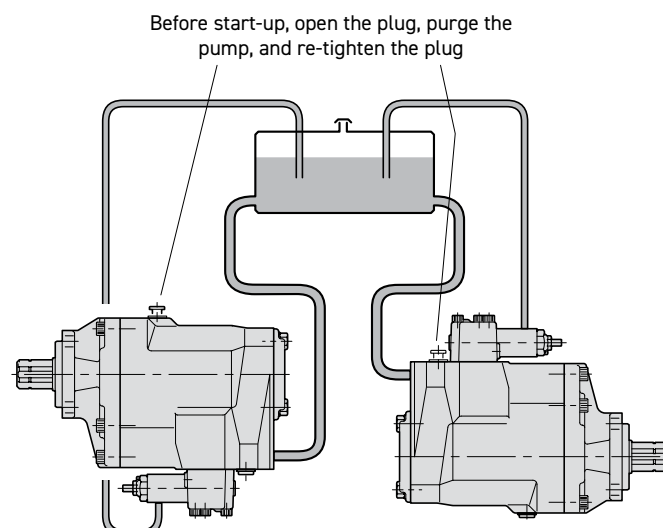

Fig. 8. VP1 should be installed below the reservoir fluid level. Purging should be performed when the pump is connected to the reservoir and the system is filled with fluid.

