

A-LOK® ASSEMBLY & REMAKE INSTRUCTIONS

1 Insert the tube into the fitting until it is fully bottomed.

2 Rotate the nut until it is finger tight.

3 Mark the nut in the 6 o'clock position.

4 Tighten the nut with a suitable wrench an additional 1-1/4 turns to the 9 o'clock position.

For sizes below 6mm/1/4" - 3/4 turn only.

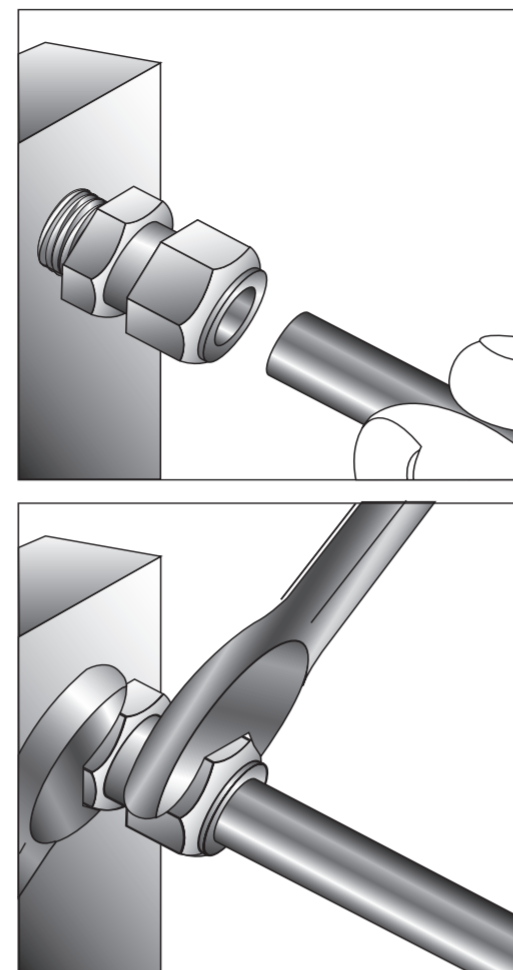

1-1/4 TURN

From the marked position

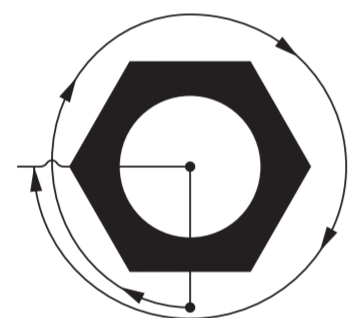

1/4" - 1"
6 - 25mm

3/4 TURN

From the marked position

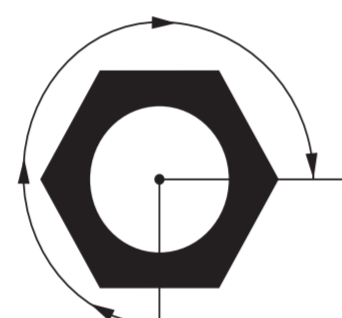

1/16" - 3/16"
2 - 4mm

GAUGEABILITY

Use Parker Inspection Gauge to ensure that correct turns of the nut are made.

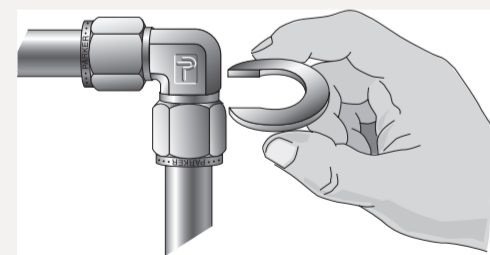

Place the gauge between the nut and the body hex. If gauge does not fit between them, you have correctly tightened the nut. If you can slip the gauge into the space, the fitting is not properly made up, and you must repeat the assembly procedure.

NOTE: Parker Inspection Gauge should only be used on original make up.

RETIGHTENING AND DISASSEMBLY

Parker tube fittings can be disassembled and re-tightened many times and the same reliable, safe, leak-proof connection obtained.

1 Re-insert the tube back into the fitting body. Ensure it is fully seated. The mark on the nut will return to approximately the 7 o'clock position.

Turn the nut back with a wrench to the original 9 o'clock position or nearly 1/4 of a turn.

2 A noticeable increase in mechanical resistance will be felt indicating the ferrule is being re-sprung into sealing position.



Parker Double Ferrule Compression Tube Fitting A-LOK®

The fitting is remade.

For sizes above 16 (1"), the Parker IPD Hydraulic Presetting Tool or Rotary Wrench Tool should be used.

SPECIAL ASSEMBLY

Plugs and Port Connectors only



PLUG

For plugs and this end of port connectors, only 1/4 turn from finger tight is necessary.



PORT CONNECTOR

Tighten this end of port connector 1-1/4 turns from finger tight.

NOTE: Lubrication of the nut is REQUIRED for proper assembly on all LARGER size fittings in both inch and metric sizes. This requirement applies to:

- inch sizes of 20 and higher
- metric sizes of 25 and higher

CAUTION: Do not make up Parker fittings or any instrumentation tube fitting by torque or 'feel' since variables in all fitting connections such as tubing and fitting tolerances, wall thickness of the tubing and lubricity of nut lubricants can result in improperly assembled tubing connections.



Parker Hannifin Manufacturing Ltd.
Instrumentation Products Division Europe
Riverside Road, Pottington Business Park
Barnstaple, Devon, EX31 1NP
United Kingdom
Tel.: +44 (0) 1271 31 31 31

You Tube Watch How to Assemble A-LOK Fittings on YouTube
youtube.com/ParkerHannifinCorp

www.parker.com/ipd