

ecodry K-MT 1-4

Efficient compressed air adsorption dryers



In any manufacturing facility, equipment up-time is essential for high productivity and low operational costs. Clean, dry compressed air ensures that a manufacturing plant is kept running efficiently and cost effectively by helping to eliminate contamination related equipment failures.

Compressed air contamination problems can be simply avoided by installing Parker's ecodry K-MT Series high efficiency compressed air adsorption dryer package fitted with Parker donnick hunter OIL-X Series filtration, which are 3rd party validated for performance. These compact packages are suitable for use with any compressor type and are well-matched with point of use applications.

For applications that fluctuate in operating pressure, temperature and flow, the K-MT adsorption dryer series offers an optional energy saving technology called dewpoint dependent switching (DDS). This feature automatically adapts the dryer operation to the inlet conditions and compressed air demand. This energy savings technology ensures energy consumed by the dryer is proportional to the amount of water vapor present, which in turn limits the number of cycles on the dryer's valves and significantly reduces the purge air usage required for regeneration.



Features

- Efficient removal of water vapor from compressed air
- Delivered air quality is in accordance with all editions of ISO 8573-1, the international standard for compressed air quality
- Achieve pressure dew points of -13°F to -100°F
- Low noise level <75 db (A)
- Optional energy saving dew point dependent switching (DDS)

Benefits

- Highest quality air – meeting ISO8573-1:2010 Class 2.2.2 as standard
- Dry air eliminates corrosion and microbiological growth
- Improves production efficiency and reduces maintenance costs and downtime
- Easy and flexible installation
- Simple maintenance
- Reduced noise pollution



ENGINEERING YOUR SUCCESS.

Product Specification

ecodry K-MT 1-4 adsorption dryer series

Dryer Performance

Dryer Models	Dewpoint (Standard)		ISO8573-1:2010 Classification (Standard)	Dewpoint (Option 1)		ISO8573-1:2010 Classification (Option 1)
	°C	°F		°C	°F	
K-MT	-40	-40	Class 2.2.2	-25	-13	Class 2.3.2

ISO8573-1 Classifications when used with Parker domnick hunter OIL-X pre / post filtration

Technical Data

Dryer Models	Min Operating Pressure		Max Operating Pressure		Min Operating Temperature		Max Operating Temperature		Max Ambient Temperature		Electrical Supply (Standard)	Electrical Supply (Optional)	Filter Thread Connections (standard)	Filter Thread Connections (optional)	Noise Level
	bar g	psi g	bar g	psi g	°C	°F	°C	°F	°C	°F					
K-MT	5	73	15	218	5	41	50	122	50	122	115 1ph 50/60Hz	230V 1ph 50/60Hz	NPT	BSPP	<75

Flow Rates

Model	Pipe Size NPT (in)	Inlet Flow Rate			
		cfm	L/s	m ³ /min	m ³ /hr
K-MT 1	1/4	5	2	0.13	8
K-MT 2	1/4	9	4	0.25	15
K-MT 3	1/4	15	7	0.42	25
K-MT 4	1/4	21	10	0.58	35

Stated flows are for operation at 7 bar (g) [102 psi (g)] with reference to 20°C, 1 bar (a), 0% relative water vapor pressure. For flows at other pressures, apply the correction factors shown below.

Air quality classes, in accordance with ISO 8573-1:2010

Particulate	Class 2
Humidity / gaseous	Class 2 and Class 1 (depending upon sizing and dew point setting)
Total oil contamination	Class 2

Optional dew point sensor ZHM100

Pressure dew point at 100 psig	-40 °F factory setting; adjustable via the menu from -13 to -100 °F
--------------------------------	---------------------------------------------------------------------

Materials of construction

Filters	See product-specification regarding domnick hunter OIL-X filters
Pressure vessels	Aluminium
Valve blocks	Aluminium
Seals	NBR
Filling	100 % Molecular sieve

Pressure vessel approvals

EU	Approval for fluid group 2 in accordance with the Pressure Equipment Directive 97/23/EC. Product range K-MT1 to 2, in accordance with article 3, paragraph 3; product range K-MT3 to 4 in accordance with category I (module A).
USA	Approval to ASME VIII Div. 1 not required
AUS	Approval to AS1210 not required
GUS	TR (formerly GOST-R)

Product Specification

ecodry K-MT 1-4 adsorption dryer series

Dimensions (in) and weight (lb)

Model	A	B	C	D	E	Weight
K-MT 1	12.8	15.7	8.5	14.8	4	25.4
K-MT 2	12.8	22.6	8.5	21.7	4	34.2
K-MT 3	12.8	32.5	8.5	31.5	4	44.1
K-MT 4	12.8	42.3	8.5	41.4	4	55.1

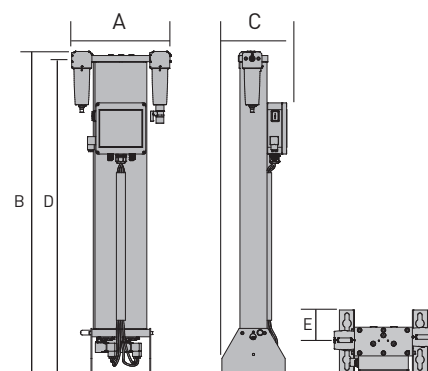

Quality assurance

Development/Manufacture	DIN EN ISO 9001, DIN EN ISO 14001
-------------------------	-----------------------------------

Product Selection & Correction Factors

CFIT - Correction Factor Maximum Inlet Temperature

Maximum Inlet Temperature	°C	25	30	35	40	45	50
	°F	77	86	95	104	113	122
Correction Factor		0.94	0.95	1.00	1.15	1.22	1.28

CFAT - Correction Factor Maximum Ambient Temperature

Maximum Ambient Temperature	°C	25	30	35	40	45	50
	°F	77	86	95	104	113	122
Correction Factor		1.00	1.00	1.00	1.00	1.00	1.00

CFP - Correction Factor Minimum Inlet Pressure

Minimum Inlet Pressure	bar g	5	6	7	8	9	10	11	12	13	14	15
	psi g	73	87	100	116	131	145	160	174	189	203	218
Correction Factor		1.33	1.12	1.00	0.88	0.79	0.76	0.74	0.67	0.62	0.59	0.56

CFD - Correction Factor Dewpoint

Required Dewpoint	°C	-25	-40
	°F	-13	-40
Correction Factor		1.00	1.00

For correct operation, compressed air dryers must be sized using for the minimum pressure, maximum temperature and maximum flow rate of the installation. To select a dryer, first calculate the MDC (Minimum Drying Capacity) using the formula below then select a dryer from the flow rate table above with a flow rate equal to or above the MDC.

$$\text{Minimum Drying Capacity} = \text{System Flow} \times \text{CFIT} \times \text{CFAT} \times \text{CFP} \times \text{CFD}$$

Product key

Series	Range*	Nominal pressure	Version	Generation	Connections*	Mains voltage*	Controls	Options*
K	1 - 4	/16	D	3	- G	230	M	T
K	1 - 4	/16	D	3	- G	24D	M	
K	1 - 4	/16	D	3	- N	115	M	

Examples

K	3	/16	D	3	- G	230	M	
K-MT 3 standard version with G1/4" (BSP-P) connections, 230V/50-60Hz Multitronic -plus control.								
K	3	/16	D	3	- N	115	M	T
K-MT 3 with NPT1/4" connections, 115V/50-60Hz Multitronic-plus control and dewpoint sensor ZHM100								

* variable information

- Note: Option T for dewpoint sensor ZHM100 provides dewpoint dependent switching (DDS) and dewpoint display

Product Specification

ecodry K-MT 1-4 adsorption dryer series

Product Catalog Numbers for Dryers and Filters

For Dryer Model	Catalog Number	Inlet General Purpose Pre-filter (optional)	Inlet High Efficiency Filter (included)	Outlet Dust Filter (included)
K-MT 1	K1/16D3-N115M	AOP010ANFI	AAP010ANFI	AOP010ANMI
K-MT 2	K2/16D3-N115M	AOP010ANFI	AAP010ANFI	AOP010ANMI
K-MT 3	K3/16D3-N115M	AOP010ANFI	AAP010ANFI	AOP010ANMI
K-MT 4	K4/16D3-N115M	AOP010ANFI	AAP010ANFI	AOP010ANMI

For correct operation and to ensure the ISO8573-1 air quality classifications are met, the above Parker domnick hunter filtration must also be installed. Filtration should be ordered separately.

Service Kits for Preventative Maintenance

Order No.	Suitability	Voltage	Interval	Scope of supply
SKK1-K4/D3/12	K-MT 1 - K-MT 4	115V & 230V	12/36 months	Reset module, silencer, and filter elements
SKK1-K4/D3/24	K-MT 1 - K-MT 4	115V & 230V	24 months	Reset module, wear part set for in-/outlet valves, silencer, and filter elements
SKK1-K4/D3/48/115	K-MT 1 - K-MT 4	115V	48 months	Reset module, wear part set for in-/outlet valves, solenoid coils, non-return valves, demister, perforated plate, perforated plate gaskets, silencer, and filter elements
SKK1-K4/D3/48	K-MT 1 - K-MT 4	230V		

DESPACs: Amount of required desiccant packs for each model - for preventative maintenance after 48 months

Order No.	K-MT 1	K-MT 2	K-MT 3	K-MT 4
DESPAC1MS	1		1	
DESPAC4MS		1	1	2

Loose accessories

Order No.	Function	Suitability	Order No.	Function	Suitability
VASRGR/K1-K8	Regeneration gas return	K-MT 1 - K-MT 4	VASNOZ/K1-K95	Nozzle kit	K-MT 1 - K-MT 4
VASDPDP/K1-K95	Dew point measurement	K-MT 1 - K-MT 4	VASVPB/K1-K4/08	Start-up device G1/4i	K-MT 1 - K-MT 4
VASMBS420	Signal duplicator 4-20 mA	K-MT 1 - K-MT 4	VASF3/K1-K4	Fine filter muffler	K-MT 1 - K-MT 4

