



SENSORS AND SWITCHES

for pressure, temperature, level and flow.

All the instruments meet the guidelines of the European Community (EU).
It is confirmed that these products are approved acc. to following standards.



DIN/EN 61000-6-2
DIN/EN 61000-6-3



Note!

This document and other information from Parker Hannifin GmbH, provide product or system options for further investigation by users having technical expertise. Before you select or use any product or system it is important that you analyse all aspects of your application and review the information concerning the product or system in the current product catalogue. Due to the variety of operating conditions and applications for these products or systems, the user, through his own analysis and testing, is solely responsible for making the final selection of the products and systems and assuring that all performance and safety requirements of the application are met. The products are subject to change by Parker Hannifin GmbH at any time without notice.

Technical subject to change. May 2026.

© Copyright 2026, Parker Hannifin Corporation. All Rights Reserved.







Table of Contents

| | Page |
|---|--------------|
| Product overview | 4-5 |
| Selection guide pressure sensors | 6 |
| Selection guide pressure controller | 7 |
| Pressure sensors | 9-38 |
| SCP03 pressure sensor | 10-13 |
| SCP04 pressure sensor | 15-19 |
| SCP08 pressure sensor | 20-21 |
| SCP09 pressure sensor | 22-26 |
| SCP10 pressure sensor | 27-31 |
| SCP11 pressure sensor | 32-35 |
| SCPSi pressure switch | 36-38 |
| Temperature sensors | 39-43 |
| SCT03 temperature sensor | 39-43 |
| Volumetric flow rate sensors | 43-59 |
| SCQ flow meter | 46-49 |
| SCFT measurement turbine | 50-53 |
| SCVF volume counter | 54-59 |
| I/O-Link Switch Family | 60-82 |
| SCPSDI Pressure Switch | 62-65 |
| SCTSDI Temperature Switch | 66-69 |
| SCTSDI Modular Temperature Switch | 70-74 |
| SCLSDI Level Switch | 75-78 |
| SCLTSDI Level/Temperature Switch | 79-82 |
| Accessories | 83-86 |
| SCK cable | 83-84 |
| SCA adapter | 85-86 |
| Installation and safety instructions | 87 |
| EMC | 87 |
| Compatibility with media (substances) | 87 |
| Pressure range selection | 87 |
| Appendix | 88 |
| Conversion charts | 88 |
| Index | 88 |
| Old and new references | 88 |

Product overview

Measurement

Pressure and temperature sensors

| SCP03 | SCP04 | SCP08 |
|---|---|---|
|  |  |  |
| Pressure sensor for mobile and industrial applications | Pressure transmitter for hydrogen applications | Pressure sensor for press construction and die-casting |
| Page 10-13 | Page 15-19 | Page 20-21 |
| SCP09 | SCP10 | SCP11 |
|  |  |  |
| Pressure sensor for industrial applications in the mid and high pressure ranges | For explosive environment with ATEX | Pressure Transmitter for hydrogen applications with ATEX approval |
| Page 22-26 | Page 27-31 | Page 32-35 |



SCPSi



Pressure switch with IO-Link

Page 36-38

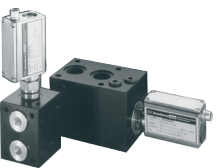

Volumetric flow rate sensors



| SCQ | SCFT | SCVF |
|---|--|---|
|  |  |  |
| For quick flow changes Measures in both directions | Low loss measuring of volume flow | Measures different substances Measures lower volume flows (leakage measurements) |
| Page 46-49 | Page 50-53 | Page 54-59 |

Product overview

Measurement, display and switching

I/O-Link Switch Family

| SCPSDI | SCTSDI | SCLSDI |
|---|---|---|
|  |  |  |
| Pressure display and monitoring | Temperature display and level monitoring | Level display and monitoring |
| Page 62-65 | Page 66-69 | Page 74-78 |

| SCLTSDI | SCTSDI Modular |
|---|---|
|  |  |
| Level/temperature display and monitoring | |
| Page 79-82 | Page 70-73 |

Accessories

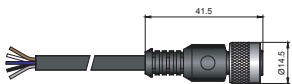
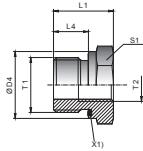
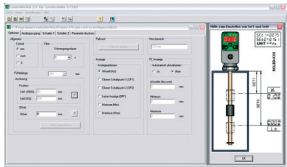
| SCK cable | SCA adapter | Software ControllerWIN |
|---|---|---|
|  |  |  |
| Page 83-84 | Page 85-86 | Page 87-88 |

Selection guide pressure sensors

| | | SCP03 | SCP04 | SCP08 | SCP09 |
|------------------------|------------------------------------|----------------------------|----------------------------|-------------------------------------|--------------------------|
| Pressure-range | 0...bar / (psi) relative | 04...1000 (58...14,504) | 04...1000 (58...14,504) | 250/400/600/1000 (3626...14,504) | 10...600 (145...8702) |
| | -1...bar / -14.5 (psi) relative | 3...24 (43,5...348) | | | |
| | 0...bar / (psi) absolut | | | | |
| Order qty. | | 50 pcs | 50 pcs | 1 / 5 / 50 pcs | |
| Accuracy | | 0,5 % | 0,5 % | 0,5 % | 0,5 % |
| Display | | | | | |
| Output | Switching Output | | | | |
| | IO-Link | | | | |
| | 0,5...4,5 V (ratiometric 5V) | • | • | | • |
| | 0,5...4,5 V (nominal 24V) | • | | | • |
| | 0...5 V | • | | | • |
| | 1...6 V | • | | | |
| | 0...10 V | • | • | • | • |
| | 0...20 mA | • | | | |
| | 4...20 mA (3-wire) | • | | | |
| | 4...20 mA (2-wire) | • | • | • | • |
| CAN | | | | | |
| Electrical Plug | M12 | • | • | • | • |
| | DIN EN 175301-803 Form A | • | • | • | • |
| | DIN Micro 9.4 | | | | |
| | AMP Superseal | • | | | |
| | Deutsch DT04 4-pin | • | | | |
| | Deutsch DT04 3-pin | • | • | | |
| | Junior Timer | • | | | |
| | Cable 2m | • | | | |
| Thread | G1/4 BSPP ED | • | • | • | • |
| | G 1/4 O-ring | • | | | |
| | 1/4 NPT | • | • | | • |
| | 7/16-20 UNF | • | • | | • |
| | 9/16-20 UNF | • | | | |
| Wetted parts | Stainless steel/ Soft sealing | FKM | | FKM | FKM |
| | Stainless steel/ Metall sealing | | • | | |
| Approvals | CE | • | | • | • |
| | Marine | | | | |
| | Safety SIL / PL | | | | |

Pressure sensors

Device features

- Long-term stability
- Immune to interference
- Rugged design
- Reliable



SensoControl[®] sensors feature long-term stability, interference immunity, a sturdy high-quality construction and a wide range of variants.

The sensors are designed and manufactured in our own production facilities under established standards for the industrial instrumentation and control systems. This allows us to easily adapt them to customer requirements or to critical applications.

We carefully consider the special requirements for automation and mobile hydraulics during the design phase. So our **SensoControl**[®] sensors are ideally suitable for the permanent series use in industrial and mobile applications.

Pressure sensors

The housing and all parts of the pressure sensors that touch the substances are manufactured from stainless steel. This provides a large range of media tolerability. A wide range of applications is possible due to the combination of high interference immunity and high resistance to external influences (shock, vibration and temperature).

The application areas are varied: from process engineering test rigs, conveying and lifting equipment, mobile hydraulics, general machine construction, pneumatic construction and hydraulic plant construction.

The SCP should be used when the pressure needs to be monitored reliably for long periods.

In this case the optimal sensor type can be selected from different product series according to the needs of the application. Different connecting plugs, output signals and connection threads are also available.

Pressure sensors - Overview

SCP03



Range of use Pressure sensor for mobile and industrial applications

- Up to 1000 bar
- G1/4 DIN 3852-11 (E)
- Compact design
- Long term stability
- Wide temperature range -40...125°C

SCP04



Range of use Pressure sensor for hydrogen applications

- Stainless steel measuring cell
- Small design
- Stainless steel housing
- Up to 1000 bar
- EC79/2009 (up to 600 bar)
- High protection degree
- Resistant to shock and vibration

SCP08



Range of use Pressure sensor for press construction and die-casting

- 250 / 400 / 600 / 1000 bar G1/4"
- 0-10 V / 4...20 mA 2-wire
- M12x1 / DIN
- Reinforced internal design
- Persistence against shock & vibration
- Made for high pressure acceleration
- High dynamic signal

Application

- | | | |
|--|---|---|
| <ul style="list-style-type: none"> ■ Mobile hydraulic ■ Transport vehicles ■ Conveyor vehicles ■ Commercial vehicles ■ Automotive technology ■ Brake systems ■ Oil pressure ■ Test equipment and technology ■ Gearbox control | <ul style="list-style-type: none"> ■ Hydrogen applications | <ul style="list-style-type: none"> ■ Press construction ■ Die-casting |
|--|---|---|

Order code

SCP03-xxx-xx-xx

SCP04-xxx-xx-0xQ8

SCP08-xxxx-x4-0x

Refer to page

10-13

15-19

20-21

SCPSi



Range of use

IO-Link Pressure sensor or switch

- Pressure sensor / -switch
- Temperature measurement
- Industry 4.0-ready
- IO-Link 1.1
- Smart Sensor Profile 2nd edition
- Plug & Play
- Compact
- Optimized design
- Adjustable via IO-link
- Readable via IO-Link
- Useable as IO-Link sensor or switch
- Monolithic pressure cell

Application

- Injection-mould machines
- Tool-making machines
- Power packs
- Special machine construction
- Replacement for mechanical pressure switches



Order code

SCPSi-xxx-04-07

Refer to page

29-31

Pressure sensors - Overview

| | SCP09 | SCP10 | SCP11 |
|----------------------|---|--|---|
| |  |  |  |
| Range of use | <p>Pressure sensor for industrial applications, inc. injection molding</p> <ul style="list-style-type: none"> ■ Up to 600 bar ■ G1/4 DIN 3852-11 (E)" ■ 0-10 V / 4...20 mA 2-wire ■ M12x1 / DIN ■ Reinforced internal design ■ Extreme persistence against shock & vibration ■ Made for mid and high pressure acceleration | <p>Pressure transmitter for use with liquid and gaseous media in hazardous areas</p> <ul style="list-style-type: none"> ■ Up to 1000 bar ■ Monolithic design ■ High media compatibility ■ Negative pressure resistant ■ ATEX approved | <p>Pressure transmitter for chemical and physical requirements of hydrogen</p> <ul style="list-style-type: none"> ■ For Hydrogen ■ Optimized media connections ■ High media compatibility ■ EC79/2009 (up to 600 bar) ■ Negative pressure resistant ■ Monolithic design |
| Application | <ul style="list-style-type: none"> ■ Hydraulics and pneumatics ■ Mobile hydraulics and Off-Highway Vehicles ■ Pumps and Compressors ■ Air Conditioning and Refrigeration Systems ■ Plant Engineering and Automation | <ul style="list-style-type: none"> ■ For explosive environment ■ ATEX approved ■ Universal applicable ■ Mobile hydraulic ■ Industrial hydraulic ■ Off and onshore | <ul style="list-style-type: none"> ■ Hydrogen application with ATEX approval |
| Order code | SCP09-xxx-xx-xx | SCP10-xxx-xx-xx | SCP11-xxx-xx-xx |
| Refer to page | 22-26 | 27-31 | 32-35 |

SCP03 pressure sensor

Device features

- Monolithic design
 - No internal seal
 - No material mix
 - No weld seam
- High media compatibility
- Measuring range from -1 to 1000 bar / -14.5 to 14,504 psi
- Negative pressure resistant
- Many connections



The SCP03 is a pressure sensor for liquid and gaseous media.

The digitally calibrated piezoresistive measuring cell detects negative pressures from -1 bar up to high pressures of 1000 bar.

The pressure connection in contact with the medium has a monolithic design. This eliminates the need for internal seals and weld seams. A mix of materials is avoided.

The resulting low permeability in combination with the stainless steel results in broad media resistance.

The compact stainless-steel housing allows space-saving use, even in harsh environmental conditions. With its wide range of pressure ranges, output signals and connectors, the SCP03 can be used in industrial and mobile applications.

The packaging variant optimized for OEM's is environmentally friendly, cost-optimized and facilitates handling.

Typical application range

- Mobile hydraulics
- Transport vehicles
- Conveyor vehicles
- Commercial vehicles
- Automotive technology
- Brake systems
- Oil pressure
- Test equipment and technology
- Gearbox control

SCP03 pressure sensor

Technical data

| SCP03- | 004R | 010R | 010R | 025R |
|--|-------------|------------|-------------|-------------|
| Pressure range -1 ... bar P _n relative (-14.5 ... psi) | 3 (43,5) | 9 (130) | 15 (218) | 24 (348) |

| SCP03- | 004 | 010 | 016 | 025 | 035 | 040 | 060 | 100 | 250 | 400 | 500 | 600 | 1000 |
|--|--------------------|-------------|-------------|-------------|-------------|-------------|-------------|---------------|---------------|---------------|---------------|---------------|------------------|
| Pressure range P _n relative 0 ... bar / (psi) | 4 (58) | 10 (145) | 16 (232) | 25 (363) | 35 (500) | 40 (580) | 60 (870) | 100 (1450) | 250 (3626) | 400 (5800) | 500 (7300) | 600 (8702) | 1000 (14,504) |
| Overload pressure P _{max} DIN EN 60770-1 (bar) relative | 2 x P _n | | | | | | | | | | | | |
| Burst pressure P _{burst} DIN EN 60770-1 (bar) relative | 3 x P _n | | | | | | | | | | | | |

| SCP03- | 0150P | 0250P | 1000P | 3000P | 5000P | 9000P |
|--|--------------------|-------|-------|-------|-------|-------|
| Pressure range P _n relative 0... (psi) | 150 | 250 | 1000 | 3000 | 5000 | 9000 |
| Overload pressure* P _{max} | 2 x P _n | | | | | |
| Burst pressure** P _{burst} | 3 x P _n | | | | | |

| General | | |
|---|-----------------------|-----------------------|
| Response time | ≤1 ms | |
| Load change | > 100 million | |
| Material Housing | EN/DIN 1.4301 | |
| Material Electr. Connector | PBT-GF30 black | |
| Weight | Approx. 80 g | |
| Accuracy parameter | | |
| Non-linearity + Hysteresis + Repeatability | ≤0.35 %FS | |
| Long-term stability | ≤ ± 0.25 %FS / year | |
| Overall Accuracy | | |
| | < 10 bar (145 psi) | ≥ 10 bar (145 psi) |
| @ 25°C | ≤ 0.5 %FS | ≤ 0.5 %FS |
| -40°C bis 105°C | +/-2,5% | |
| @ 0°C...+85°C | ≤ 2 %FS | ≤ 1 %FS |

| Ambient conditions | |
|---------------------------------|----------------------------------|
| Media temperature | -40...+125 °C / (-40...257°F) |
| Operation / Ambient temperature | -40...+105 °C / (-40...221°F) |
| Storage temperature | -40...+125 °C / (-40...257°F) |
| Vibration resistance | IEC 60068-2-6: 20 g |
| Shock resistance | IEC 60068-2-27: 1000 g |
| Conformity | |
| CE | EN 61326-1 EN61326-3-1 |
| RoHs | Yes |
| MTTFd | > 100 years |

| Process connection | Torque | Seal | Wetted parts |
|----------------------------------|--------|-----------------|---------------------|
| G1/4A BSPP; DIN 3852 T11, Form E | 25 Nm | DIN 3869-14-FKM | EN/DIN 1.4404 / FKM |
| SAE-4: 7/16-20 UNF O-ring | 25 Nm | FKM | EN/DIN 1.4404 / FKM |
| SAE 6: 9/16-18 UNF O-ring | 25 Nm | FKM | EN/DIN 1.4404 / FKM |
| G1/4 DIN ISO 228-1 O-ring | 25 Nm | FKM | EN/DIN 1.4404 / FKM |
| 1/4 NPT | 25 Nm | | EN/DIN 1.4404 |

SCP03 pressure sensor

Pin assignment

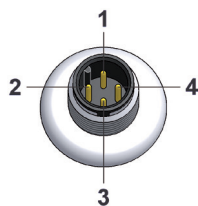

| Output signal | (2 wire) 4...20 mA | 0...20 mA 4...20 mA | 0.5...4.5 V 0...5 V | 1...6 V 0...10 V | 0.5...4.5 V ratio. |
|--|--|------------------------|------------------------|---------------------|-----------------------|
| Supply Voltage V_+ | 10...32 VDC | 12...32 VDC | 8...32 VDC | 12...32 VDC | 5 V \pm 10% |
| Load _{max} | $\leq (V_+ - 10V) / 20 \text{ mA}$ [k Ω] | | 4.7 [k Ω] | | |
| Overvoltage | 50 VDC | | | | |
| Short circuit | Yes | | | | |
| Reverse polarity | Yes | | | | |
| Signal on GND / V_+ | Yes | | | | |
| M12x1 4-pole | | | | | |
| Pin 1 | V_+ | | | | |
| Pin 2 | P-Signal | | | | |
| Pin 3 | n.c. | 0 V / GND | | | |
| Pin 4 | n.c. | n.c. | | | |
| IP65 (for $p \geq 60$ bar IP67)* | | | | | |
| DIN EN 175301-803 Form A 4-pole (old 43650) | | | | | |
| Pin 1 | P-Signal | | | | |
| Pin 2 | n.c | 0 V / GND | | | |
| Pin 3 | V_+ | | | | |
| Pin 4 / GND | n.c | | | | |
| IP54 | | | | | |
| AMP Superseal 1.5 | | | | | |
| Pin 1 | P-Signal | 0 V / GND | | | |
| Pin 2 | n.c | P-Signal | | | |
| Pin 3 | V_+ | | | | |
| IP65 (for $p \geq 60$ bar IP67)* | | | | | |
| DT04-4P | | | | | |
| Pin 1 | V_+ | | | | |
| Pin 2 | P-Signal | 0 V / GND | | | |
| Pin 3 | n.c | P-Signal | | | |
| Pin 4 / GND | n.c | | | | |
| IP65 (for $p \geq 60$ bar IP67)* | | | | | |
| DT04-3P | | | | | |
| A | V_+ | | | | |
| B | n.c | P-Signal | | | |
| C | P-Signal | 0 V / GND | | | |
| IP 67 | | | | | |
| Junior Timer | | | | | |
| Pin 1 | P-Signal | 0 V / GND | | | |
| Pin 2 | n.c | P-Signal | | | |
| Pin 3 | V_+ | | | | |
| IP65 (for $p \geq 60$ bar IP67)* | | | | | |
| Cable | | | | | |
| Bn | V_+ | | | | |
| Black | P-Signal | | | | |
| Blue | n.c | 0 V / GND | | | |
| IP 67 | | | | | |

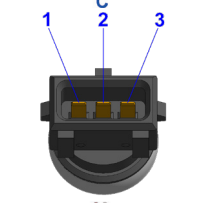
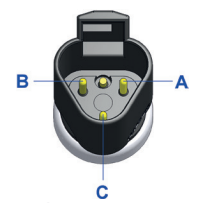
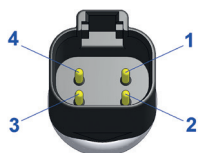
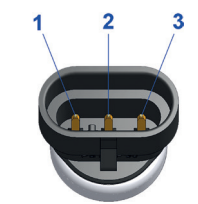
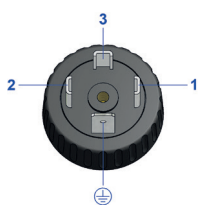

*IP67 when plugged

SCP03 pressure sensor

Pin assignment

Connectors & Ports

SCP03-...-x7

M12 4P

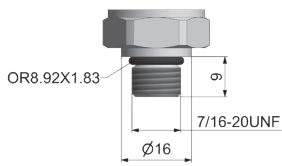

SCP03-...-x6

DIN EN 175301-803
Form A

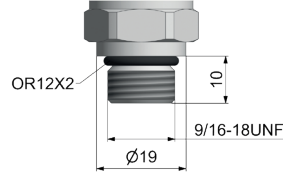

SCP03-...-xD

DT04 4P

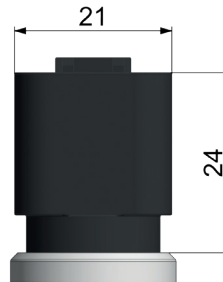

SCP03-...-xE

DT04 3P

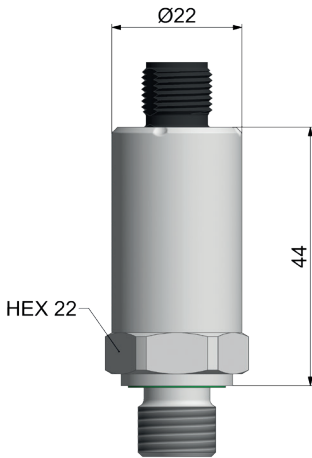
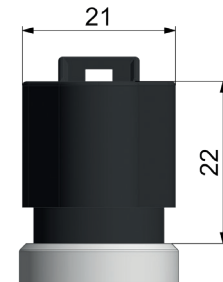

SCP03-...-xA

Superseal

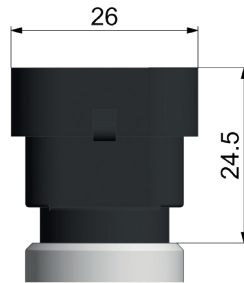

SCP03-...-xJ

Junior Timer 3P

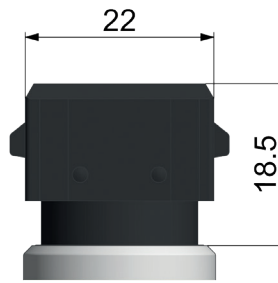

SCP03-...-x0

Kabel

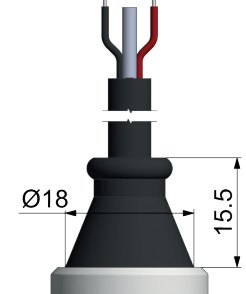

SCP03-xxx-x6-xx

SAE 06 - O-ring

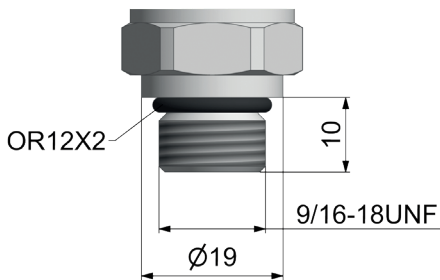

SCP03-xxx-x7-xx

SAE 04 - O-ring

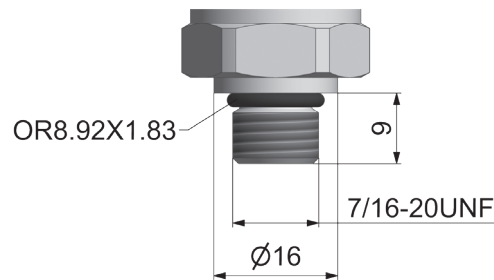

SCP03-xxx-x5-xx

1/4 NPT

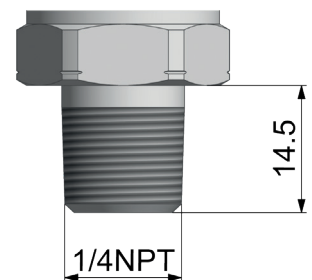

SCP03-xxx-x4-xx

G 1/4, DIN 3852 T 11 (Form E)

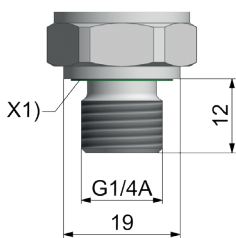

SCP03-xxx-x8-xx

G 1/4, O-ring

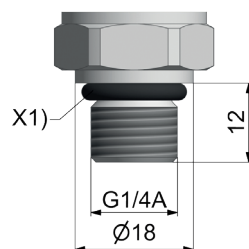

SCP03-xxx-xx-Dx

G 1/4, with damping

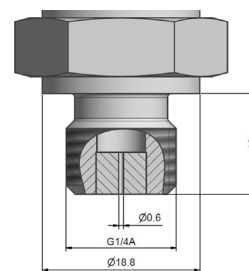

SCP03-xxx-xx-xx

G 1/4, without damping

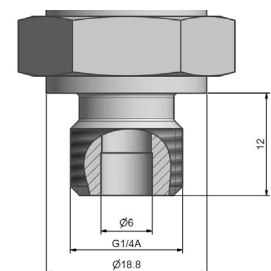

X1) = ED-Seal

X1) = O-ring



SCP03 pressure sensor

Order code

Order quantity

Available single versions

Pressure sensor SCP03 Industrial SCP03-xxx-xx-Dx

| Pressure range | Code |
|----------------|------|
| 0...10 bar | 010 |
| 0...25 bar | 025 |
| 0...60 bar | 060 |
| 0...250 bar | 250 |
| 0...400 bar | 400 |
| 0...600 bar | 600 |

Output signal

| | |
|--------------------|---|
| 4...20 mA (3-wire) | 2 |
| 4...20 mA (2-wire) | 3 |
| 0...10 V | 4 |

Process connection

| | |
|-----------|---|
| G1/4 BSPP | 4 |
|-----------|---|

With damping **D**

Connecting plug

| | |
|--|---|
| Device connector DIN EN 175301-803 Form A 4-pole | 6 |
| Circular connector M12x1 4-pole | 7 |

Pressure sensor SCP03 Mobile SCP03-xxx-xx-Dx

| Pressure range | Code |
|----------------|------|
| 0...10 bar | 010 |
| 0...25 bar | 025 |
| 0...60 bar | 060 |
| 0...250 bar | 250 |
| 0...400 bar | 400 |
| 0...600 bar | 600 |

Output signal

| | |
|---------------------------|---|
| 4...20 mA (2-wire) | 3 |
| 0.5...4.5 V (ratiometric) | R |

Process connection

| | |
|-----------|---|
| G1/4 BSPP | 4 |
|-----------|---|

With damping **D**

Connecting plug

| | |
|-------------------------|---|
| Device plug DT04 4 pole | D |
|-------------------------|---|

Order example

150x SCP03-400-34-07Q8

150 Single sensors (multiple of 50's)

Pressure range 0...400 bar

Output signal 4 to 20 mA (2-wire)

G1/4 BSPP

Without damping

M12 connecting plug 4-pole



Pressure sensor SCP03

Pressure range

| Pressure range | Code |
|----------------|-------|
| -1...3 bar | 004R |
| -1...9 bar | 010R |
| -1...15 bar | 016R |
| -1...24 bar | 025R |
| 0...4 bar | 004 |
| 0...10 bar | 010 |
| 0...16 bar | 016 |
| 0...25 bar | 025 |
| 0...35 bar | 035 |
| 0...60 bar | 060 |
| 0...100 bar | 100 |
| 0...160 bar | 160 |
| 0...250 bar | 250 |
| 0...400 bar | 400 |
| 0...500 bar | 500 |
| 0...600 bar | 600 |
| 0...1000 bar | 1000 |
| 0...150 psi | 0150P |
| 0...250 psi | 0250P |
| 0...1000 psi | 1000P |
| 0...3000 psi | 3000P |
| 0...5000 psi | 5000P |
| 0...9000 psi | 9000P |

Output signal

| | |
|---------------------------|---|
| 0...20 mA | 1 |
| 4...20 mA (3-wire) | 2 |
| 4...20 mA (2-wire) | 3 |
| 0...10 V | 4 |
| 0...5 V | A |
| 1...6 V | B |
| 0.5...4.5 V (ratiometric) | R |
| 0.5...4.5 V (nom.) | S |

Process connection

| | |
|---|---|
| G1/4 BSPP | 4 |
| 1/4 NPT (P _n max. = 600 bar) | 5 |
| 9/16-18 UNF, SAE 6 O-ring (P _n max. = 400 bar) | 6 |
| 7/16-20 UNF SAE-4 O-ring (P _n max. = 400 bar) | 7 |
| G1/4 O-ring (P _n max. = 600 bar) | 8 |

Damping

| | |
|-----------------|---|
| Without damping | 0 |
| With damping | D |

Connecting plug

| | |
|--|---|
| Device connector DIN EN 175301-803 Form A 4-pole | 6 |
| Circular connector M12x1 4-pole | 7 |
| Stationary cable 2 m | 0 |
| Device plug AMP Superseal | A |
| Device plug DT04 4 pole | D |
| Device plug DT04 3 pole | E |
| Junior Timer 3-pole | J |

Minimum order qty:

Q8: Multiple of 50 pcs.

SCP04 pressure sensor

Device features

- Monolithic design
 - No internal seal
 - No material mix
 - No weld seam
- EC79/2009 approved (up to 600 bar)
- High media compatibility (hydrogen)
- Up to 1000 bar (up to 14,504 psi)
- Negative pressure resistant
- Special connections



The SCP04 pressure sensor is designed to meet the chemical and physical requirements of hydrogen applications.

The digitally calibrated piezoresistive stainless steel measuring cell detects pressures up to 1000 bar. The connection to the sensing elements is made via a special bonding and thus remains stable even at low temperatures, shocks or vibrations.

The measuring cell and the pressure connection in contact with the medium are made in one piece. This eliminates the need for internal seals and weld seams. A mix of materials is avoided. The construction was designed to prevent embrittlement of the metal surface by ionized hydrogen.

The monolithic design eliminates leakage due to material fatigue at internal seals. The SCP04 has no pressure transfer fluid, no large pressurized areas, and is vacuum-tight and elastomer-free.

The resulting low permeability in combination with the stainless steel results in a wide media resistance. The process connections have been designed to be gasket-free for hydrogen applications.

The compact stainless steel housing allows space-saving use, even under harsh environmental conditions.

Typical application range

- Hydrogen applications

SCP04 pressure sensor

Technical data

| SCP04- | 004 | 025 | 400 | 500 | 600 | 1000 |
|---|-----------|-------------|---------------|---------------|---------------|------------------|
| Pressure range P_n relative 0 ... bar / (psi) | 4 (58) | 25 (363) | 400 (5800) | 500 (7300) | 600 (8702) | 1000 (14,504) |
| Overload pressure P_{max} DIN EN 60770-1 (bar) relative | 2 x P_n | | | | | 1,4 x P_n |
| Burst pressure P_{burst} DIN EN 60770-1 (bar) relative | 3 x P_n | | | | | 2 x P_n |

| General | | |
|--|-----------------------|-----------------------|
| Response time | ≤1 ms | |
| Load change | > 10 million | |
| Material Housing | EN/DIN 1.4301 | |
| Weight | Approx. 120 g | |
| MTTFd | > 100 years | |
| Accuracy parameter | | |
| BFSL: Non-linearity, Zero-point error, Hysteresis, Repeatability | ≤0.35 %FS | |
| Limit-point setting | ≤0.5 %FS | |
| Resolution | FS/1500 digit | |
| Long-term stability | ≤0.3 %FS / year | |
| Overall Accuracy | | |
| | < 10 bar (145 psi) | ≥ 10 bar (145 psi) |
| @ 25°C | ≤0.5 %FS | ≤0.5 %FS |
| @ -5°C...+85°C | ≤2 %FS | ≤1.5 %FS |
| @ -40°C...+105°C | ≤3 %FS | ≤2 %FS |

| Ambient conditions | |
|---------------------------------|----------------------------------|
| Media temperature | -40...+125 °C / (-40...257°F) |
| Operation / Ambient temperature | -40...+105 °C / (-40...221°F) |
| Storage temperature | -40...+125 °C / (-40...257°F) |
| Vibration resistance | IEC 60068-2-6: 20 g |
| Shock resistance | IEC 60068-2-27: 100 g |
| Conformity | |
| CE | EN 61326-1 EN 61326-2-3 |
| RoHs | 2011/65/EU |

| Process connection | Torque | Wetted parts |
|----------------------|--------|---------------------------|
| 7/16"-20UNF-2A | 25 Nm | 316L; EN/DIN 1.4404 / FKM |
| 9/16"-18UNF-2A | 35 Nm | 316L; EN/DIN 1.4404 / FKM |
| 9/16"-18UNF-2A / 59° | 25 Nm | 316L; EN/DIN 1.4404 |
| G1/4 B (EN 837) | 25 Nm | 316L; EN/DIN 1.4404 |
| 1/4 NPT | 25 Nm | 316L; EN/DIN 1.4404 |

SCP04 pressure sensor

Pin assignment



M12x1 (S763)



DIN EN 175301-803
Form A



DT04-3P

| Output signal | (2 wire) 4...20 mA | 0...10 V | 0.5...4.5 V ratio. |
|--|--|-------------|--------------------|
| Supply Voltage V_+ | 10...32 VDC | 12...32 VDC | 5 V \pm 10% |
| Load _{max} | $\leq (V_+ - 10V) / 20 \text{ mA}$ [k Ω] | | 4,7 [k Ω] |
| Overvoltage | 50 VDC | | |
| Short circuit | Yes | | |
| Rever polarity | Yes | | |
| Signal on GND / V_+ | Yes | | |
| M12x1 4-pole | | | |
| Pin 1 | V_+ | | |
| Pin 2 | P-Signal | | |
| Pin 3 | n.c. | 0 V / GND | |
| Pin 4 | n.c. | n.c. | |
| IP65 (for $p \geq 50$ bar IP67)* | | | |
| DIN EN 175301-803 Form A 4-pole (old 43650) | | | |
| Pin 1 | P-Signal | | |
| Pin 2 | n.c | 0 V / GND | |
| Pin 3 | V_+ | | |
| Pin 4 / GND | n.c | | |
| IP 54 | | | |
| DT04-3P | | | |
| A | V_+ | | |
| B | n.c | P-Signal | |
| C | P-Signal | 0 V / GND | |
| IP 67 | | | |

*IP67 when plugged

SCP04 pressure sensor

Pin assignment

Connectors & Ports

SCP04-...-...-07

M12 4P

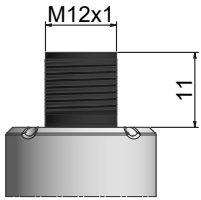

SCP04-...-...-06

DIN EN 175301-803

Form A

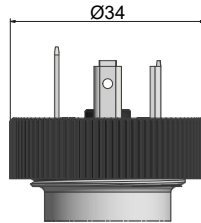

SCP04-...-...-0E

DT04 3P

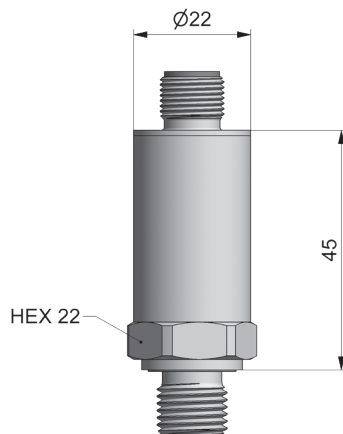
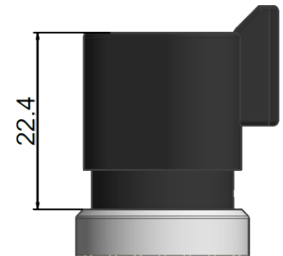

SCP04-xxx-x7-0x

7/16"-20UNF-2A

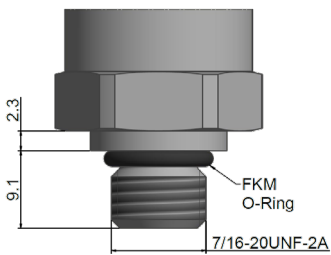

SCP04-xxx-x6-0x

9/16"-18UNF-2A

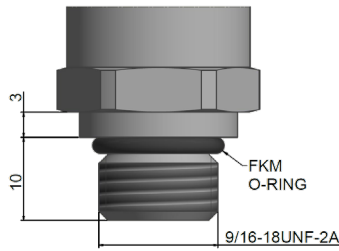

SCP04-xxx-x6M-0x

9/16"-18UNF-2M / 59°

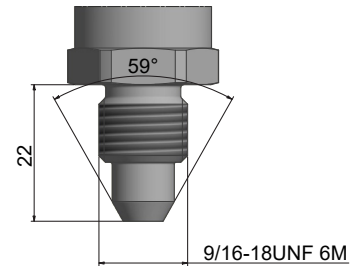

SCP04-xxx-xA-0x

G 1/4 B (EN 837)

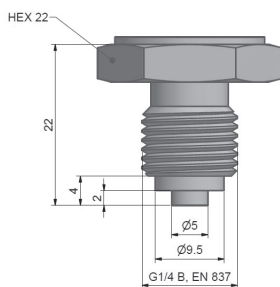

SCP04-xxx-x5-0x

1/4 NPT

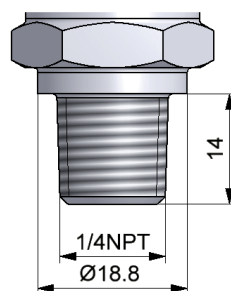

SCP04 pressure sensor

Order code

| Pressure sensor SCP04 | SCP04-xxx-xx-0xQ8 |
|--|-------------------|
| Pressure range (bar) | |
| 0...4 bar | 004 |
| 0...25 bar | 025 |
| 0...400 bar | 400 |
| 0...500 bar | 500 |
| 0...600 bar | 600 |
| 0...1000 bar**/** | 1000 |
| Output signal | |
| 4...20 mA (2-wire) | 3 |
| 0...10 V | 4 |
| 0.5...4.5 V (ratiometric) | R |
| Process connection | |
| G1/4 B (EN 837) | A |
| 1/4 NPT | 5 |
| 7/16"-20UNF-2A | 7 |
| 9/16"-18UNF-2A | 6 |
| 9/16"-18UNF-2A / 59° | M |
| Connecting plug | |
| Device connector DIN EN 175301-803 Form A 4-pole | 6 |
| Circular connector M12x1 4-pole | 7 |
| Device plug DT04 3 pole | E |
| Minimum order qty: | |
| Q8: Multiple of 50 pcs. | |

Additional Variances

| | |
|--|-----------|
| Individual Pressure-ranges / calibration | available |
| Additional Ports | available |
| Individual Pin configuration | available |
| Brand label | available |

*Up to EC79 600 bar approved

**Only thread 9/16"-18UNF-2M / 59°

Pressure sensor SCP08 for presses

Device features

- 250 / 400 / 600 / 1000 bar
(3,626 / 5,802 / 8,702 / 14,504 psi)
- G1/4"
- 0-10V / 4...20mA 2-wire
- M12x1 / DIN
- Reinforced internal design
- Persistence against shock & vibration
- Made for high pressure acceleration
- High dynamic signal



Particularly in die-casting applications the controlling for the piston requires a high dynamic pressure sensor. During this fast, high energetic process the components are stressed by shock, vibration and pressure acceleration.

The pressure sensor SCP08 measures the pressure via a special designed measurement cell and has a high adapted overload pressure to withstand the pressure peaks.

To avoid abrasion of the cell due to Diesel or similar effects, the process connection is protected by an adjusted drilling. The dimension of the drilling still guarantees an instantaneous pressure response.

To increase shock and vibration resistance, the relevant internal components are covered and reinforced. The speed of the sensor influences directly the quality of the production process.

The unique combination of accuracy, durability and high dynamic response makes the SCP08 ideal for the requirements of die-casting applications.

Typical applications

- Press construction
- Die-casting

Pressure sensor SCP08

Technical data

| SCP08- | 250 | 400 | 600 | 1000 |
|--|------------------|------------------|------------------|------------------|
| Pressure range P_n 0... bar / (psi) relative | 250 (3626) | 400 (5802) | 600 (8702) | 1000 (14,504) |
| Overload pressure P_{max} bar / (psi) relative | 1000 (14,504) | 1200 (17,405) | 1200 (17,405) | 1500 (21,756) |
| Burst pressure P_{burst} bar / (psi) relative | 1500 (21,756) | 1500 (21,756) | 1800 (26,107) | 2000 (29,008) |

General

| | |
|------------------|---|
| Response time | 0...10 V $\leq 0,3$ ms 4...20 mA 2-Leiter $\leq 0,5$ ms* |
| Load change | >10 million. |
| Material Housing | Stainless steel 304 |
| Weight | Approx. 80 g |

Ambient Conditions

| | |
|----------------------------------|------------------------------|
| Media temperature | -40...125°C / (-40...257°F) |
| Operation- / Ambient temperature | -40 to 105°C / (-40...221°F) |
| Storage temperature | -40 to 125°C / (-40...257°F) |
| Vibration | 20 g rms |
| Shock | 1 m on concrete |

Conformity

| | |
|----|-----|
| CE | yes |
|----|-----|

Overall Accuracy

| | |
|----------------------|-----------------------|
| @ RT *1 | $\leq 0,5$ %FS |
| @ -10°C...85°C *1 *2 | ≤ 2 %FS |
| @ -40...105°C *1 *2 | $\leq 2,5$ %FS |
| Long-term stability | $\leq 0,2$ %FS / year |

*1 incl. Non-linearity + Hysteresis + Offset + Gain

*2 incl. Repeatability + Temperature effects

RT = Room Temperature 20°C

Process Connection

| | |
|--------------------|-----------------------------|
| Thread | G1/4, DIN 3852 T11 (E) |
| Eroding milling | 0,6 mm |
| Volume measured | < 1 mm ³ |
| Seal | ED Type: FKM |
| Material | Stainless steel 17-4 PH |
| Material diaphragm | Stainless steel 17-4 PH |
| Wetted parts | FKM Stainless steel 17-4 PH |

Installation

| | |
|---------------------|----------------|
| Installation torque | Max. 35 Nm |
| General | no restriction |

Recommended preventive activities to avoid air inclusion:

- Bleed air
- Installation with Process connection on top

*with 2 m cable



| Output signal | 0...10 V | 4...20 mA 2-wire |
|----------------------|----------------------|-------------------------|
| Supply voltage V_+ | 12...32 VDC | 10...32 VDC |
| Load _{max} | 10 k Ω | $(V_+ - 10$ V) / 20 mA |
| Protection | Overvoltage | 36 signal on GND/ V_+ |
| | Short circuit | yes |
| | Reverse polarity | yes |
| | Signal on GND/ V_+ | yes |

M12x1

| Protection class (mounted connector) | IP67 | 0...10 V | 4...20 mA 2-wire |
|--------------------------------------|----------------|----------------|------------------|
| Pin 1 | V_+ | V_+ | V_+ |
| Pin 2 | P-signal | P-signal | P-signal |
| Pin 3 | V_- | Do not connect | Do not connect |
| Pin 4 | Do not connect | Do not connect | Do not connect |

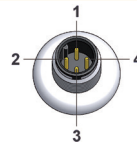

DIN EN 175301-803 Form A

| Protection class (mounted connector) | IP65 | 0...10 V | 4...20 mA 2-wire |
|--------------------------------------|----------------|----------------|------------------|
| Pin 1 | V_+ | V_+ | V_+ |
| Pin 2 | V_- | P-signal | P-signal |
| Pin 3 | P-signal | Do not connect | Do not connect |
| Pin 4 | Do not connect | Do not connect | Do not connect |

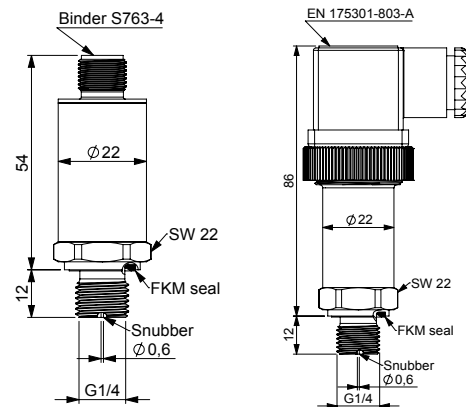
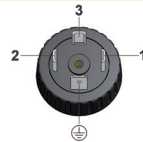

Order code

Pressure sensor SCP-08

4...20 mA; 2-wire

Pressure range (bar)

| | |
|--------------|------|
| 0...250 bar | 250 |
| 0...400 bar | 400 |
| 0...600 bar | 600 |
| 0...1000 bar | 1000 |

Output signal

| | |
|--------------------|---|
| 4...20 mA (2-wire) | 3 |
| 0...10V | 4 |

Connecting plug

| | |
|---------------------------------|---|
| DIN EN 175301-803 Form A 4 pole | 6 |
| M12x1 4 pole | 7 |

Order quantity

| | |
|-------------------------|--|
| Q2: Multiple of 5 pcs. | |
| Q8: Multiple of 50 pcs. | |

SCP08-xxxx-x4-0xQ

Pressure sensor SCP09

Device features

- Measuring range
 - from 0-10 bar to 0-600 bar (0-145 psi to 0-8700 psi)
- Wide range of
 - Ports
 - Connectors
 - Electrical outputs
- Stainless steel design
- Hermetic port
- Storage and operating media temperature
 - -40 to 125°C
- Operating ambient temp. range
 - -40 to 100°C
- Snubber option
- REACH/RoHS/CE/UKCA



The SCP09 pressure sensor is the ideal solution for customers with challenging measuring requirements for general industrial applications in the mid and high pressure ranges. The SCP09 features a wide range of ports, connectors, and analog electrical outputs for ease of integration in various industrial applications.

The SCP09's high quality stainless steel design features a hermetic port with no internal O-ring seals making it compatible with most media and suitable for harsh environments. With extreme shock and vibration capabilities, a wide operating temperature range, and high proof and burst pressures; the SCP09 is ideal for industrial applications including injection molding, CO₂, HVAC systems, and other hydraulic or pneumatic applications.

For dampening of pressure spikes due to hammer and cavitation a optional damping (Snubber) can be provided.

Typical applications

- Hydraulics and Pneumatics
- Mobile Hydraulics and Off-Highway Vehicles
- Pumps and Compressors
- Air Conditioning and Refrigeration Systems
- Plant Engineering and Automation

Pressure sensor SCP09

Technical data

| SCP09- | 010 | 016 | 025 | 040 | 050 | 060 | 100 | 160 | 200 | 250 | 350 | 400 | 500 | 600 |
|--|---------------|---------------|---------------|-----------------|-----------------|-----------------|-----------------|-----------------|-----------------|-----------------|-----------------|-----------------|-----------------|-----------------|
| Pressure range P_n relative 0 ... bar / (psi) | 10 (145) | 16 (232) | 25 (363) | 40 (580) | 50 (725) | 60 (870) | 100 (1450) | 160 (2321) | 200 (2901) | 250 (3626) | 350 (5076) | 400 (5802) | 500 (7252) | 600 (8702) |
| Overload pressure P_{max} DIN EN 60770-1 (bar) relative | 60 (870) | 60 (870) | 60 (870) | 200 (2901) | 200 (2901) | 200 (2901) | 200 (2901) | 500 (7252) | 500 (7252) | 500 (7252) | 800 (11603) | 800 (11603) | 1200 (17405) | 1200 (17405) |
| Burst pressure P_{burst} DIN EN 60770-1 (bar) relative | 200 (2901) | 200 (2901) | 200 (2901) | 2000 (29008) | 2000 (29008) | 2000 (29008) | 2000 (29008) | 2500 (36259) | 2500 (36259) | 2500 (36259) | 4000 (58015) | 4000 (58015) | 4000 (58015) | 4000 (58015) |

| General | |
|--|--|
| Response time | ≤2 ms |
| Durability | > 10 million |
| Accuracy parameter | |
| Basic Accuracy IEC 61298-2 (Non-linearity + Hysteresis + zero & span) | ± 0.5 %FS @ 25°C |
| BFSL Accuracy IEC 60770-1 (Non-linearity + Hysteresis + repeatability, excluding zero & span) | ± 0.25 %FS @ 25°C |
| Non-linearity BFSL | ± 0.2 % FS |
| Non-repeatability | ± 0.1 % FS |
| Overall Accuracy | |
| @ -20°C...+85°C | ± 1.5 %FS |
| Ambient conditions | |
| Media temperature | -40...+125 °C / (-40...257°F) |
| Operation temperature | -40...+100 °C / (-40...212°F) |
| Storage temperature | -40...+125 °C / (-40...257°F) |
| Vibration resistance | IEC 60068-2-6: 30 g (10...2000Hz) |
| Shock resistance | IEC 60068-2-27: 500 g |
| Conformity | |
| CE Emission / Immunity | EN 61326 |
| RoHs / REACH | Yes |
| UKCA | Yes |
| Radiated Immunity | 100V/m @80...200MHz 200V/m @200...2700MHz |

| Process connection | Torque | Seal | Wetted parts |
|-------------------------------|--------|------|-----------------------------|
| G1/4A DIN3852 T11, Form E | 25 Nm | FKM | 17-4PH EN/DIN 1.4542 ; FKM |
| 7/16-20 UNF-2A J1926-3 O-ring | 25 Nm | HNBR | 17-4PH EN/DIN 1.4542 ; HNBR |
| 1/4-19 PT (BSPT) (R1/4) | 25 Nm | – | 17-4PH EN/DIN 1.4542 |
| 1/4-18 NPTF | 25 Nm | – | 17-4PH EN/DIN 1.4542 |

Pressure sensor SCP09

Pin assignment

| Output signal | (2 wire) 4...20 mA | 0.5...4.5 V 0...5 V 1...5 V | 0...10 V | 0.5...4.5 V ratio. |
|--|--|-----------------------------------|--------------------------|--------------------------|
| Supply Voltage V_+ | 8...32 VDC | 8...32 VDC | 12...32 VDC | 5 V \pm 0.25 VDC |
| Overvoltage | 36 VDC | 36 VDC | 36 VDC | – |
| Short circuit | – | Yes | Yes | Yes |
| Reverse polarity | Yes | Yes | Yes | Yes |
| Load _{max} | $\leq (V_+ - 8V) / 20mA$ [k Ω] | ≥ 4.7 [k Ω] | ≥ 4.7 [k Ω] | ≥ 4.7 [k Ω] |
| M12x1 4-pole | | | | |
| Pin 1 | V_+ | V_+ | V_+ | V_+ |
| Pin 2 | n.c. | n.c. | n.c. | n.c. |
| Pin 3 | P-Signal | 0 V / GND | 0 V / GND | 0 V / GND |
| Pin 4 | n.c. | P-Signal | P-Signal | P-Signal |
| IP 67 | | | | |
| DIN EN 175301-803 Form A 4-pole (old 43650) | | | | |
| Pin 1 | V_+ | V_+ | V_+ | V_+ |
| Pin 2 | P-Signal | 0 V / GND | 0 V / GND | 0 V / GND |
| Pin 3 | n.c. | P-Signal | P-Signal | P-Signal |
| Pin 4 / GND | n.c. | n.c. | n.c. | n.c. |
| IP 65 | | | | |
| DT04-3P | | | | |
| A | V_+ | V_+ | V_+ | V_+ |
| B | P-Signal | 0 V / GND | 0 V / GND | 0 V / GND |
| C | n.c. | P-Signal | P-Signal | P-Signal |
| IP 67 | | | | |
| Metri-Pack 150 | | | | |
| A | P-Signal | 0 V / GND | 0 V / GND | 0 V / GND |
| B | V_+ | V_+ | V_+ | V_+ |
| C | n.c. | P-Signal | P-Signal | P-Signal |
| IP 67 | | | | |

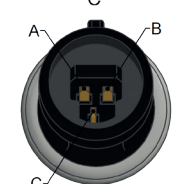
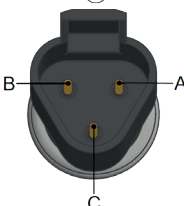
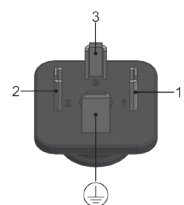
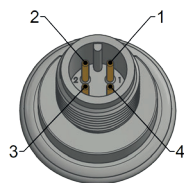

Pressure sensor SCP09

Pin assignment Connectors & Ports

SCP09-...-...-07
M12 4P

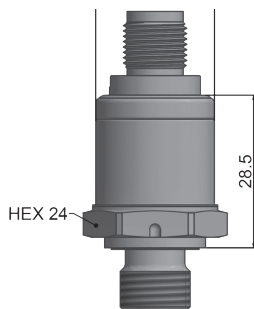

SCP09-...-...-07
M12x1 4-pole

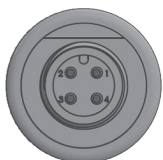
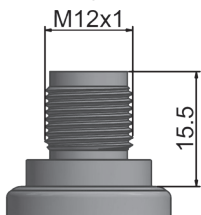

M12 4P

SCP09-...-...-06
DIN EN 175301-803 - Form A



DIN EN 175301-803
FORM A

SCP09-...-...-0E
DT04 3P

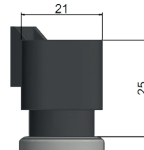

DT04 3P

SCP09-...-...-0P
Packard Metri Pack 150

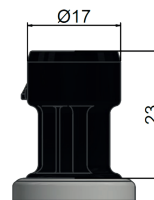

Packard Metri Pack 150

SCP09-xxx-x4-xx
G 1/4, DIN 3852 T 11 (Form E)

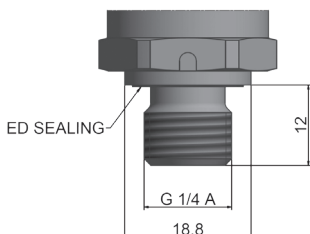

G1/4A (MALE) DIN 3852-E

SCP09-xxx-x7-xx
7/16-20 UNF-2A

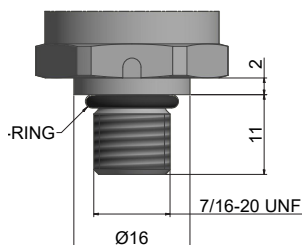

7/16-20 UNF J1926-3

SCP09-xxx-xR-xx
1/4-19PT (R1/4)

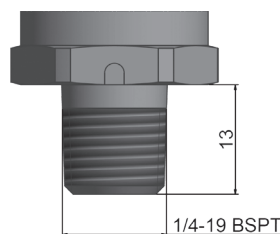

1/4-19 PT(BSPT) (R1/4)

SCP09-xxx-x5-xx
1/4-18NPT

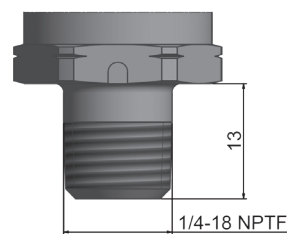

1/4-18 NPTF

Optional with damping (Snubber)

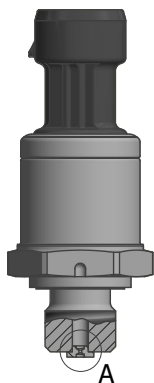
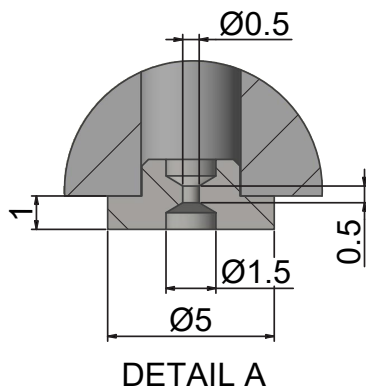

Pressure sensor SCP09

Order code

| Pressure sensor SCP09 | SCP09-xxx-xx-xxQ |
|--|------------------|
| Pressure range | |
| 0...10 bar | 010 |
| 0...16 bar | 016 |
| 0...25 bar | 025 |
| 0...40 bar | 040 |
| 0...50 bar | 050 |
| 0...60 bar | 060 |
| 0...100 bar | 100 |
| 0...160 bar | 160 |
| 0...250 bar | 250 |
| 0...350 bar | 350 |
| 0...400 bar | 400 |
| 0...500 bar | 500 |
| 0...600 bar | 600 |
| Output signal | |
| 4...20 mA (2-wire) | 3 |
| 0...10 V | 4 |
| 0...5 V | A |
| 1...5 V | D |
| 0.5...4.5 V @ 5±0.25VDC (ratiometric) | R |
| 0.5...4.5 V @ 8-32VDC (nom.) | S |
| Process connection | |
| G1/4A DIN 3852-E | 4 |
| 1/4-18 NPT | 5 |
| 7/16-20 UNF -2A | 7 |
| 1/4 -19PT (R1/4) | R |
| Damping | |
| Without damping | 0 |
| With damping | D |
| Connecting plug | |
| Device connector DIN EN 175301-803 Form A 4-pole | 6 |
| Circular connector M12x1 4-pole | 7 |
| DT04 3 pole | E |
| Packard | P |
| Order quantity: | |
| Q8: Multiple of 50 pcs. | |
| Q10: Multiple of 500 pcs. | |

Pressure transmitter SCP10

Device features

- ATEX
 - II 1G Ex ia IIC T4 Ga
 - II 2G Ex ia IIC T4 Gb
 - II 1G Ex ia IIB T4 Ga
- Monolithic design
 - No internal seal
 - No material mix
 - No weld seam
- High media compatibility
- Up to 1000 bar
- Negative pressure resistant



The intrinsically safe pressure sensor SCP10 has been specially developed for use with liquid and gaseous media in hazardous areas. It fulfills the requirements for conditions in:

Zone 0: II 1G Ex ia IIC T4 Ga

II 1G Ex ia IIB T4 Ga

Zone 1: II 2G Ex ia IIC T4 Gb

This sensor ensures maximum safety in critical environments.

The digitally calibrated piezoresistive stainless steel measuring cell detects pressures from 4 bar up to 1000 bar. The connection to the sensing elements is made via a special bonding and therefore remains stable even at low temperatures, shocks or vibrations.

The measuring cell and the pressure connection in contact with the medium are made from a single piece. This eliminates the need for internal seals and weld seams. A mix of materials is avoided.

Due to the monolithic design, leaks caused by material fatigue at joints are excluded by design.

The SCP10 has no pressure transmission fluid, no large pressurized surfaces and is absolutely vacuum-tight and elastomer-free.

The resulting low permeability in combination with the stainless steel results in broad media resistance.

The compact stainless steel housing enables space-saving use, even in harsh environmental conditions.

With the wide range of pressure ranges, output signals and connectors, the SCP10 can be used in industrial and mobile applications.

Pressure transmitter SCP10

Technical data

| SCP10- | 004 | 010 | 016 | 025 | 060 | 100 | 250 | 400 | 600 | 1000 |
|---|------------|-------------|-------------|-------------|-------------|---------------|---------------|---------------|---------------|-----------------|
| Pressure range 0... bar P _n relative 0... (psi) | 4 (580) | 10 (145) | 16 (232) | 25 (362) | 60 (870) | 100 (1450) | 250 (3625) | 400 (5801) | 600 (8702) | 1000 (14503) |
| Overload pressure P _{max} (bar) relative | 8 | 20 | 32 | 50 | 120 | 200 | 500 | 800 | 1200 | 1400 |
| Burst pressure P _{burst} (bar) relative | 12 | 30 | 48 | 75 | 180 | 500 | 1000 | 1400 | 1800 | 2000 |

| Accuracy | |
|---------------------------------|--|
| Long-term stability | ± 0.5 %FS @ 25°C |
| Overall Accuracy | @ 25°C ≤ ± 0,5 %FS |
| | @ -5°C ...+85°C ≤ ± 1.5 %FS |
| | @ -40°C...+85 °C ≤ ± 2.5 %FS |
| General | |
| Response time | ≤2 ms |
| Pressure cycles | > 100 million |
| Material Housing | EN/DIN 1.4301 |
| Weight | Approx. 100 g |
| RoHs | Yes |
| MTTFd | >100 years |
| ATEX | |
| M12 metallic connector | II 1G Ex ia IIC T4 Ga |
| Other connector | II 1G Ex ia IIB T4 Ga II 2G Ex ia IIC T4 Gb |
| Certificate | IBExU24ATEX1042 EN IEC 60079-0 EN 60079-11 |
| Ambient conditions | |
| Media temperature | -40 to 100 °C (-40 to 212 °F) |
| Operation / Ambient temperature | |
| Zone 0 | -20 to 60 °C |
| Zone 1 / 2 | -40 to 85 °C (-40 to 185 °F) |
| Storage temperature | -40 to 85 °C (-40 to 185 °F) |
| Vibration | IEC 60068-2-6: 20 g / 3 axes |
| Shock | IEC 60068-2-31 (1m free fall) |
| CE emission | EN 61326-1:2013 - section 7 EN 61326-2-3:2013 |
| CE susceptibility | EN 61326-1:2013 - section 6 EN 61326-2-3:2013 |

| Process connection | Torque | Seal | Wetted parts |
|--------------------|--------|------|----------------------------|
| 7/16-20UNF-2A | 25 Nm | FKM | 316L (EN/DIN 1.4404) / FKM |
| 9/16-18UNF-2A | 35 Nm | FKM | 316L (EN/DIN 1.4404) / FKM |
| G1/4 Form E | 25 Nm | FKM | 316L (EN/DIN 1.4404) / FKM |
| G1/4 O-ring | 25 Nm | FKM | 316L (EN/DIN 1.4404) / FKM |
| G1/4 B | 25 Nm | none | 316L (EN/DIN 1.4404) |
| ¼ NPT | 25 Nm | none | 316L (EN/DIN 1.4404) |

Pressure transmitter SCP10

Electrical Connection



| Output signal | 4....20 mA (2wire) |
|--|-----------------------------------|
| Supply Voltage V ₊ | 20 ... 27 VDC |
| Load _{max} | < (V _{cc} -10 V) / 20 mA |
| Current consumption | 3.6 ... 21.4 mA |
| Reverse polarity | Yes |
| Oversvoltage protection | Yes |
| M12x1 4-pole | |
| Pin 1 | V+ |
| Pin 2 | P-Signal |
| Pin 3 | n.c. |
| Pin 4 | n.c. |
| Protection Class (connected) | IP 67 |
| ATEX | II 1G Ex ia IIC T4 Ga |
| DT04-3P | |
| A | V+ |
| B | n.c. |
| C | P-Signal |
| Protection Class (connected) | IP 67 |
| ATEX | II 2G Ex ia IIC T4 Gb |
| | II 1G Ex ia IIB T4 Ga |
| DIN EN 175301-803 Form A 4-pole | |
| 1 | P-Signal |
| 2 | n.c. |
| 3 | V+ |
| GND | n.c. |
| Protection Class (connected) | IP 65 |
| ATEX | II 2G Ex ia IIC T4 Gb |
| | II 1G Ex ia IIB T4 Ga |
| Conduit | |
| Red | V+ |
| Black | P-Signal |
| Protection Class (connected) | IP68 |
| ATEX | II 2G Ex ia IIC T4 Gb |
| | II 1G Ex ia IIB T4 Ga |
| Cable | |
| Red | V+ |
| Black | P-Signal |
| Protection Class (connected) | IP 67 |
| ATEX | II 2G Ex ia IIC T4 Gb |
| | II 1G Ex ia IIB T4 Ga |

Pressure transmitter SCP10

Drawings

M12x1

Metallic

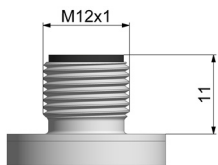

EN 175301

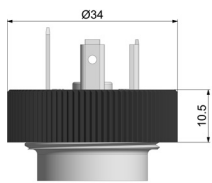

DT04

3pole

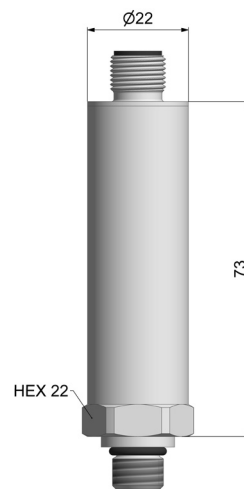
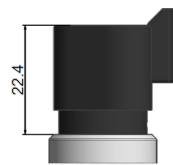

Cable (2m)

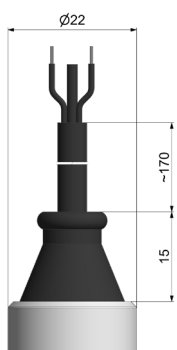

Conduit

1/2"-14 NPT (2m)

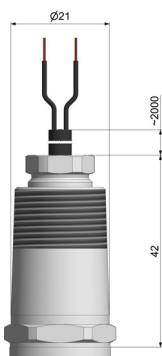

G1/4" A Form E

DIN EN ISO 1179-2

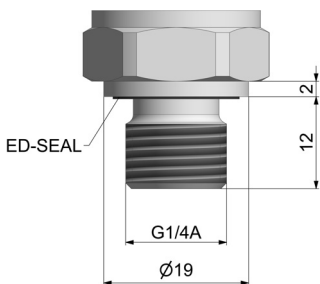

1/4"-18 NPT

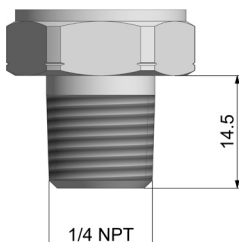

9/16-18UNF-2A

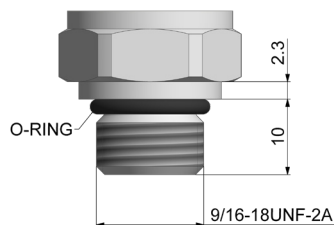

7/16-20UNF-2A

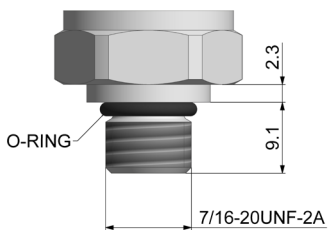

G1/4" A Form G

DIN EN ISO 1179-3

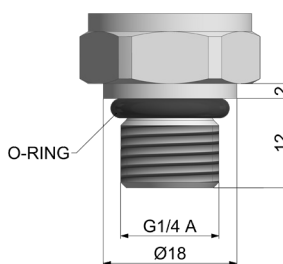

G1/4" B

EN 827

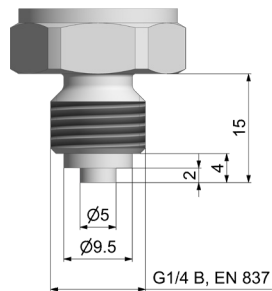

Snubber

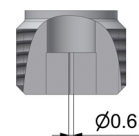

Pressure transmitter SCP10

Order code

| Pressure sensor SCP10 | SCP10-xxx | -3x | -x x | -EXi0S |
|---------------------------------|-----------|-----|------|--------|
| Pressure range | | | | |
| 0...4 bar | 004 | | | |
| 0...10 bar | 010 | | | |
| 0...16 bar | 016 | | | |
| 0...25 bar | 025 | | | |
| 0...60 bar | 060 | | | |
| 0...100 bar | 100 | | | |
| 0...250 bar | 250 | | | |
| 0...400 bar | 400 | | | |
| 0...600 bar | 600 | | | |
| 0...1000 bar | 1000 | | | |
| Output signal | | | | |
| 4...20 mA (2-wire) | | 3 | | |
| Process connection | | | | |
| G1/4"A DIN EN ISO 1179-2 Form E | | | 4 | |
| 1/4-18 NPT | | | 5 | |
| 9/16-18UNF-2A | | | 6 | |
| 7/16-20UNF-2A | | | 7 | |
| G1/4"A DIN EN ISO 1179-3 Form G | | | 8 | |
| G1/4"B EN 827 | | | A | |
| Damping | | | | |
| Without damping | | | | 0 |
| With damping | | | | D |
| Connecting plug | | | | |
| Cable 2m | | | | 0 |
| Cable 5m | | | | 005 |
| Cable 10m | | | | 010 |
| DIN EN 175301-803 Form A 4-pole | | | | 6 |
| M12x1 4-pole metallic | | | | 7 |
| DT04 3pole | | | | E |
| Conduit 1/2"-14 NPT (2m) | | | | K |

Pressure transmitter SCP11

Device features

- ATEX
 - II 1G Ex ia IIC T4 Ga
 - II 2G Ex ia IIC T4 Gb
- Monolithic design
 - No internal seal
 - No material mix
 - No weld seam
- EC79/2009 (up to 600 bar)
- High media compatibility (hydrogen)
- Up to 1000 bar
- Negative pressure resistant
- Special connections



The intrinsically safe SCP11 pressure sensor is designed to meet the chemical and physical requirements of hydrogen applications. It fulfills the requirements for conditions in:

Zone 0: II 1G Ex ia IIC T4 Ga

Zone 1: II 2G Ex ia IIC T4 Gb

This sensor ensures maximum safety in critical environments.

The digitally calibrated piezoresistive stainless steel measuring cell detects pressures from 4 bar up to 1000 bar. The connection to the sensing elements is made via a special bonding and thus remains stable even at low temperatures, shocks or vibrations.

The measuring cell and the pressure connection in contact with the medium are made in one piece. This eliminates the need for internal seals and weld seams. A mix of materials is avoided. The construction was designed to prevent embrittlement of the metal surface by ionized hydrogen.

The monolithic design eliminates leakage due to material fatigue at internal seals.

The SCP11 has no pressure transfer fluid, no large pressurized areas, and is vacuum-tight and elastomer-free.

The resulting low permeability in combination with the stainless steel results in a wide media resistance. Specifically for hydrogen applications, a seal-free process connection has been implemented.

The compact stainless steel housing allows space-saving use, even under harsh environmental conditions.

Pressure transmitter SCP11

Technical data

| SCP11- | 004 | 025 | 400 | 500 | 600 | 1000 |
|--|--------------------|-------------|---------------|---------------|---------------|----------------------|
| Pressure range 0... (bar) P _n relative 0 ... (psi) | 4 (58) | 25 (363) | 400 (5800) | 500 (7300) | 600 (8702) | 1000*1 (14503) |
| Overload pressure P _{max} (bar) relative | 2 x P _n | | | | | 1,4 x P _n |
| Burst pressure P _{burst} (bar) relative | 3 x P _n | | | | | 2 x P _n |

*1 Only in combination with 9/16-18UNF-6M / 59°

| Accuracy | |
|---------------------------------|--|
| Long-term stability | ≤ ± 0.25 %FS / year |
| Overall Accuracy | @ 25°C ≤ ± 0,5 %FS |
| | @ -5°C ...+85°C ≤ ± 1.5 %FS |
| | @ -40°C...+85 °C ≤ ± 2,5 %FS |
| General | |
| Response time | ≤2 ms |
| Pressure cycles | >100 million |
| Material Housing | EN/DIN 1.4301 |
| Weight | Approx. 100 g |
| RoHs | Yes |
| MTTFd | >100 years |
| ATEX | |
| M12 metallic connector | II 1G Ex ia IIC T4 Ga |
| Other connector | II 2G Ex ia IIC T4 Gb |
| Certificate | IBExU24ATEX1042 EN IEC 60079-0 EN 60079-11 |
| Ambient conditions | |
| Media temperature | -40 to 100 °C (-40 to 212 °F) |
| Operation / Ambient temperature | Zone 0 -20 to 60 °C |
| | Zone 1 / 2 -40 to 85 °C (-40 to 185 °F) |
| Storage temperature | -40 to 85 °C (-40 to 185 °F) |
| Vibration | IEC 60068-2-6 : 20 g / 3 axes |
| Shock | IEC 60068-2-31 (1m free fall) |
| CE emission | EN 61326-1:2013-section 7 EN 61326-2-3:2013 |
| CE susceptibility | EN 61326-1:2013 - section 6 EN 61326-2-3:2013 |

| Process connection | Torque | Seal | Wetted parts |
|--------------------|--------|------|-----------------------------|
| 7/16-20UNF-2A | 25 Nm | HNBR | 316L (EN/DIN 1.4404) / HNBR |
| 9/16-18UNF-2A | 35 Nm | HNBR | 316L (EN/DIN 1.4404) / HNBR |
| 9/16-18UNF 6M | 25 Nm | none | 316L (EN/DIN 1.4404) |
| 1/4 NPT | 25 NM | none | 316L (EN/DIN 1.4404) |

Pressure transmitter SCP11

Electrical Connection

| Output signal | 4....20 mA (2wire) |
|------------------------------|---------------------------------|
| Supply Voltage V_+ | 20 ... 27 VDC |
| Load _{max} | $< (V_{cc}-10 V)/20 \text{ mA}$ |
| Current consumption | 3.6 ... 21.4 mA |
| Reverse polarity | Yes |
| Overvoltage protection | Yes |
| M12x1 4-pole | |
| Pin 1 | V+ |
| Pin 2 | P-Signal |
| Pin 3 | n.c. |
| Pin 4 | n.c. |
| Protection Class (connected) | IP 67 |
| ATEX | II 1G Ex ia IIC T4 Ga |
| DT04-3P | |
| A | V+ |
| B | n.c. |
| C | P-Signal |
| Protection Class (connected) | IP 67 |
| ATEX | II 2G Ex ia IIC T4 Gb |

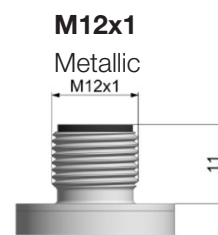
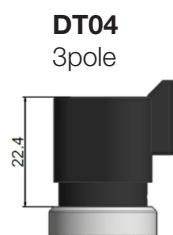

1/4"-18 NPT

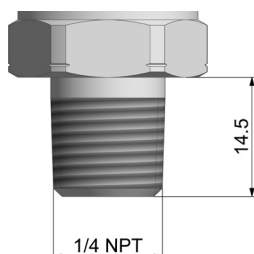

7/16-20UNF-2A

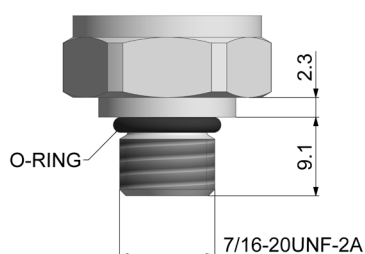

9/16-18UNF-6M

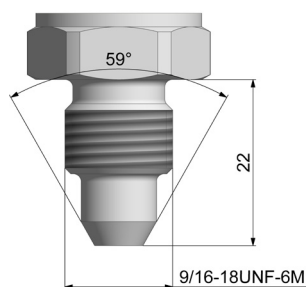

9/16-18UNF-2A

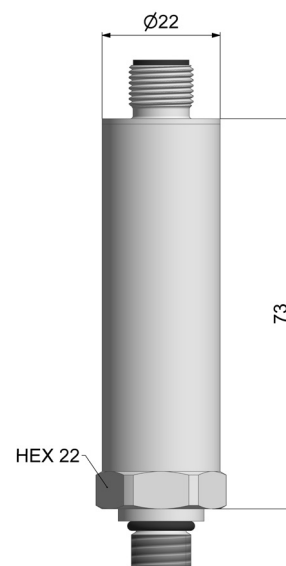
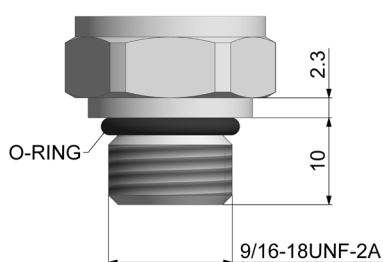

Pressure transmitter SCP11

Order code

| | | | | |
|------------------------------|--------------------|------------|--------------|--------------|
| Pressure sensor SCP11 | SCP11-xxx - | -3x | 0 x - | EXi0S |
| Pressure range | | | | |
| 0...4 bar | 004 | | | |
| 0...25 bar | 025 | | | |
| 0...400 bar | 400 | | | |
| 0...600 bar | 600 | | | |
| 0...1000 bar*1 | 1000 | | | |
| Output signal | | | | |
| 4...20 mA (2-wire) | | 3 | | |
| Process connection | | | | |
| 1/4"-18 NPT | | | 5 | |
| 7/16-20UNF-2A | | | 7 | |
| 9/16-18UNF-2A | | | 6 | |
| 9/16-18UNF-6M / 59° | | | M | |
| Connecting plug | | | | |
| M12x1 4-pole metallic | | | | 7 |
| DT04 3pole | | | | E |

*1 Only in combination with 9/16-18UNF-6M / 59°

SCPSi pressure switch

Device features

- Pressure sensor / -switch
- Temperature measurement
- Industry 4.0-ready
- IO-Link 1.1
- Smart Sensor Profile 2nd edition
- Plug & Play
- Compact
- Optimized design
- Adjustable via IO-Link
- Readable via IO-Link
- Useable as IO-Link sensor or switch
- Monolithic pressure cell



The fully electronic pressure switch SCPSi is adjustable and free from susceptible mechanical and moving components.

With its digital interface and smart functions, the SCPSi is future-proof for the increasing demands of automation solutions.

The 2 switching outputs are individually and safely parameterized from the machine control system via the standardized digital IO-Link interface (IEC 61131-9). This replaces manual programming and the commissioning phase is considerably shortened. Devices can be replaced during operation without the need for reparameterization. In order to react promptly to machine status changes or process adjustments, the re-parameterization is carried out during operation.

As an alternative to the switching functions, diagnostic values, process data and status messages are recorded directly via IO-Link and enable subsequent more complex analyses. Via the integrated temperature measurement of the pressure measuring cell, the media or ambient temperature is recorded.

IO-Link replaces time-consuming manual programming and eliminates the need for a sensitive key display with the manufacturer-dependent setting menu. This more compact, more resistant design without key display, in combi-

nation with the smart functions & setting options, opens up new possibilities in machine design for the machine designer, with considerable savings potential.

The compact stainless steel housing allows space-saving use, even in harsh environments.

The proven stainless steel measuring cell with the wide pressure range (from -1 up to 600 bar) allows a wide range of applications for liquid and gaseous media. The media-contacting pressure connection with the pressure measuring cell is monolithically manufactured from a stainless steel without welds and sets new standards in media compatibility and pressure resistance.

The packaging variant optimized for OEM's is environmentally friendly, cost-optimized and facilitates handling.

Application examples

- **Injection-mould machines**
- **Tool-making machines**
- **Power packs**
- **Special machine construction**
- **Replacement for mechanical pressure switches**

SCPSi pressure switch

Technical data

| SCPSi | | 001 | 004 | 010 | 025 | 060 | 100 | 250 | 400 | 600 |
|--|-------|---------------------------------|------------|-----------------------|-------------|-----------|------------|------------|------------|------------|
| Pressure range P _n | bar | -1...1 | -1...4 | -1...10 | -1...25 | 0...60 | 0...100 | 0...250 | 0...400 | 0...600 |
| vacuum tight / relative P _n | (psi) | (-14...14) | (-14...58) | (14...145) | (-14...362) | (0...870) | (0...1450) | (0...3625) | (0...5801) | (0...8702) |
| Overload pressure | bar | 6 | 10 | 030 | 80 | 200 | 300 | 750 | 1200 | 1400 |
| relative P _{max} | (psi) | (87) | (145) | (435) | (1160) | (2900) | (4351) | (10877) | (17404) | (20305) |
| Burst pressure | bar | 9 | 15 | 100 | 150 | 500 | 800 | 1000 | 2000 | 2200 |
| relative P _{burst} | (psi) | (130) | (217) | (1450) | (2175) | (7251) | (11603) | (14504) | (29007) | (31908) |
| Wetted parts | | 1.4542 (17-4PH); 1.4548; FKM | | Monolitisch 316L; FKM | | | | | | |
| Set point SP Range | | 1 - 100 % | | | | | | | | |
| Reset point rP Range | | 0 - 99 % | | | | | | | | |
| Steps / Incremental | mbar | 0,1 | 1 | 1 | 1 | 10 | 10 | 10 | 100 | 100 |
| Smallest hysteresis (SP-rP) & (FH-FL) | bar | 0,001 | 0,01 | 0,01 | 0,01 | 0,1 | 0,1 | 0,1 | 1 | 1 |

| General | |
|---------------------------------|-----------------------------|
| Overall Accuracy @ RT [°1] | ≤ 0,5 %FS |
| Min. pressure cycles | > 100 million |
| Material housing | Stainless steel 1.4404 |
| Weight | approx. 80 g |
| Conformity | |
| RoHS | 2011/65/EU, 2015/863 |
| CE | Yes |
| UKCA | Yes |
| Process connection | |
| Thread | G1/4, DIN 3852 T11 (E) |
| Seal | ED type: FKM |
| Installation torque | Max. 35 Nm |
| Ambient conditions | |
| Media temperature | -25 to 85 °C (-13 to 185°F) |
| Operation / Ambient temperature | -25 to 85 °C (-13 to 185°F) |
| Storage temperature | -40 to 85 °C (-40 to 185°F) |
| Vibration | DIN EN 60068-2-6, 20 g |
| Shock | DIN EN 60068-2-27, 500 g |
| MTTFd | >100 year |
| Accuracy | |
| @ -40°C...-25°C | ≤ 2,5 %FS |
| @ -25...0°C | ≤ 1,5 %FS |
| @ 0...85°C | ≤ 1 %FS |
| Temperature signal | |
| Output | Via IO-Link |
| Short circuit | -40 to 125 °C |
| Resolution | 1 K |
| Accuracy | ± 10°K |
| t _{0,9} | 80 sek. |
| Protection | |
| Overvoltage | 70 V |
| Short circuit | yes |
| Reverse polarity | yes |
| Signal on GND/V ₊ | yes |
| Factory setting | |
| SP1 / rP1 | 40 / 60% FS; Hno |
| SP2 / rP2 | 30 / 70% FS; Hno |

| Electronic Connectivity | |
|---|--|
| Power supply voltage V ₍₊₎ | 18...30VDC |
| Connector | M12 |
| Consumption | < 15 mA @ 24V |
| Output | 2 switching outputs, NPN / PNP, 1 IO-Link output |
| Switch current | Max. 200mA |
| Max. switch frequency | 200 Hz |
| Response time | ≥ 3 ms |
| IO-Link Interface | |
| Revision | IO-Link V1.1 Process Data Variable; Device Identification; Device Diagnosis |
| Min. process cycle time | 4 ms |
| Transmission type | COM2, 38.4kBaud |
| Profile | Smart Sensor Profile 2 nd Edition v1.1.2 |
| SIO-Mode | yes |
| Master port type | A |
| Process data analogue (in Pa) | 2 Byte Process data 1 Byte scaling factor |
| Process data binary | 1 byte |
| SDCI Standard | IEC 61131-9 |
| Vendor ID | 271 / 10f (hex) |
| Device IODD | https://ioddfinder.io-link.com/#/ |
| M12x1 | |
| Protection class (mounted connector) | IP67 |
|  | Pin 1 V ₍₊₎ |
| | Pin 2 S2 out |
| | Pin 3 0V / GND |
| | Pin 4 S1 out / IO-Link |

SCPSi pressure switch

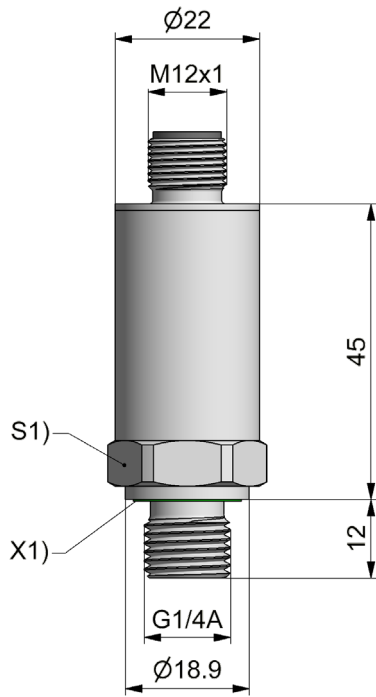

Order code

SCPSi Pressure switch

SCPSi-xxx-04-07

Druckbereich

| | |
|-------------|-----|
| 0...001 bar | 001 |
| 0...004 bar | 004 |
| 0...010 bar | 010 |
| 0...025 bar | 025 |
| 0...060 bar | 060 |
| 0...100 bar | 100 |
| 0...250 bar | 250 |
| 0...400 bar | 400 |
| 0...600 bar | 600 |

SCT03 temperature sensor

Device features

- Temperature sensor
- Wide temperature range
-50 ... +150°C
- Easy integration
 - Electrical outputs
 - Process connections
 - Electrical connectors
- High pressure resistance
 - Design
 - Robust
 - Compact
- Broad media compatibility
 - Stainless steel process connection
 - Liquids & gases

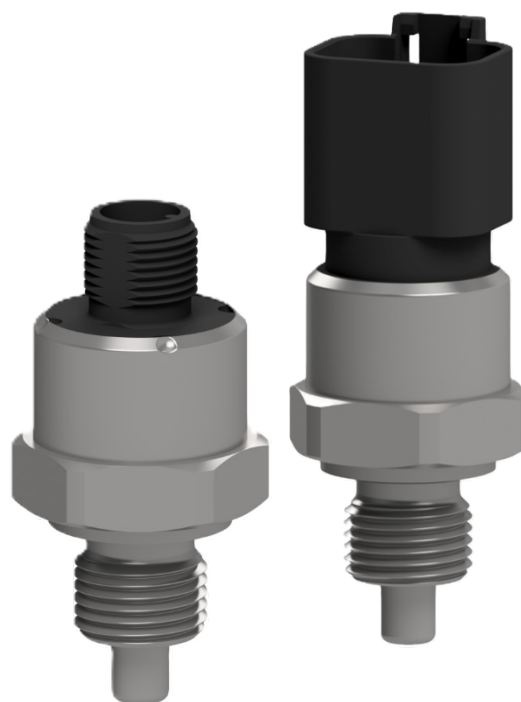

The SCT03 temperature sensor is engineered for the thermal and mechanical demands of mobile and industrial applications. It covers media temperatures from -50 to +150 °C and ambient conditions from -40 to +125 °C. With the high system pressure capability and IP67 ingress protection (mated), it is ready for harsh environments.

Industry-standard output signals and common connector/port options simplify integration.

Stainless-steel process connections enable broad media compatibility with liquids and gases.

The compact, robust metal housing makes the SCT03 well-suited for demanding applications such as mobile hydraulics.

Application examples

- Industrial hydraulics
- Mobile hydraulics
- Thermal management

SCT03 temperature sensor

Technical data

| SCT03 | 007 |
|------------------------|---------------------|
| Temperature range | -50 ... + 150°C |
| Max Pressure Pmax | 600 bar |
| Response T05 / T90 [s] | < 10 / < 30 |
| Material Housing | EN/DIN 1.4404; 316L |
| Weight | Approx. 45 g |
| RoHs | Yes |
| MTTFd | >100 years |

| Ambient conditions | |
|-----------------------|--|
| Media temperature | -50 to 150 °C |
| Operation temperature | -40 to 125 °C |
| Storage temperature | -40 to 125 °C |
| Vibration resistance | IEC 60068-2-6 : 20 g / 3 axes |
| Shock resistance | IEC 60068-2-31 (1m free fall) |
| CE Emission | EN 61326-1:2013-section 7 EN 61326-2-3:2013 |
| CE susceptibility | EN 61326-1:2013 - section 6 EN 61326-2-3:2013 |

| Process connection | Torque | Seal | Wetted parts | Pressure Range |
|----------------------------------|--------|-------------------|---------------------------------|----------------|
| G1/4A BSPP; DIN 3852 T11, Form E | 25 Nm | FKM (green) *1 *2 | 316L (EN/DIN 1.4404) / FKM*1 *2 | 700bar |
| M10x1 | 25 Nm | | | 350bar |
| 9/16"-18 UNF, SAE 6 | 35 Nm | | | 1000bar |

*1 standard sealing FKM

*2 EPDM for SCT03-XXX-XX-XX-EPDM instead of FKM

SCT03 temperature sensor

Electrical Connection

| Output signal | 4...20 mA | 0,5...4,5 V ratio. | Pt100 | Pt1000 |
|-------------------------|---------------------------------|--------------------|---|---|
| Supply Voltage V+ | 10...32 VDC | 5 V ±10% | - | - |
| Element | Pt100, class B | Pt100, class B | Pt100, class B | Pt1000, class A |
| Accuracy | @25°C ≤1% FS | @25°C ≤1% FS | DIN EN 60751 ± 0,3°C ± 0,005 x ΔT _{0-C} | DIN EN 60751 ±0,15°C±0,002 x ΔT _{0-C} |
| Accuracy @FS | ≤2% FS | ≤2% FS | | |
| Load _{max} | < (V _{cc} -10 V)/20 mA | >4,7 kΩ | | |
| Current consumption | ≤22mA | max. 10 mA | | |
| Reverse polarity | yes | yes | | |
| Oversvoltage protection | ≤ 34V | ≤ 32V | | |

M12 x 1 4 pole

| | | | | |
|--------------------|----------|----------|--------|--------|
| Pin 1 | V+ | V+ | 1/2 R+ | 1/2 R+ |
| Pin 2 | P-Signal | P-Signal | 1/2 R+ | 1/2 R+ |
| Pin 3 | n.c. | 0V / GND | 3/4 R- | 3/4 R- |
| Pin 4 | n.c. | n.c. | 3/4 R- | 3/4 R- |
| Protection Class * | IP 67 | | | |

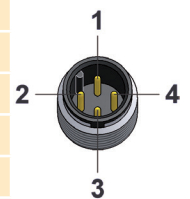

DT04-4P

| | | | | |
|--------------------|----------|----------|--------|--------|
| Pin 1 | V+ | V+ | 1/2 R+ | 1/2 R+ |
| Pin 2 | P-Signal | 0V / GND | 1/2 R+ | 1/2 R+ |
| Pin 3 | n.c. | P-Signal | 3/4 R- | 3/4 R- |
| Pin 4 | n.c. | n.c. | 3/4 R- | 3/4 R- |
| Protection Class * | IP 67 | | | |

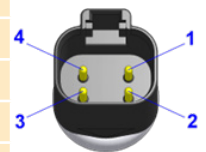

AMP JuniorTimer

| | | | | |
|--------------------|----------|----------|---|---|
| Pin 1 | P-Signal | 0V / GND | - | - |
| Pin 2 | n.c. | P-Signal | - | - |
| Pin 3 | V+ | V+ | - | - |
| Protection Class * | IP 67 | | | |

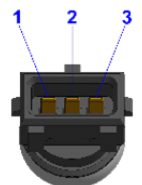

*connected/when plugged

SCT03 temperature sensor

Drawings

SCT03-007-X4-07

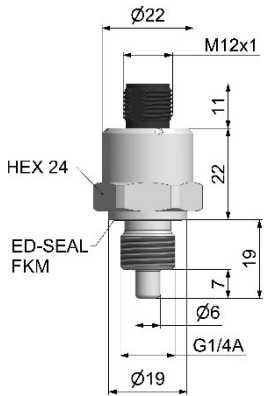

SCT03-007-XJ-07

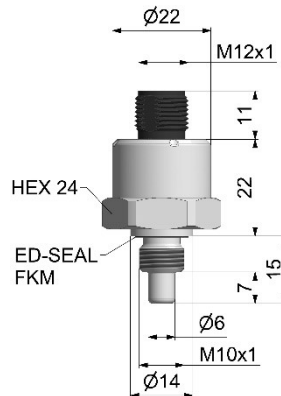

SCT03-007-X6-07

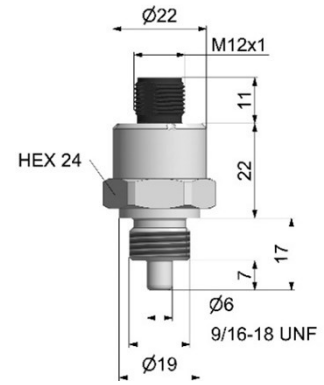

SCT03-007-X4-0D

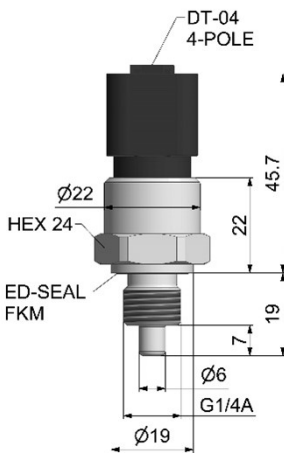

SCT03-007-XJ-0D

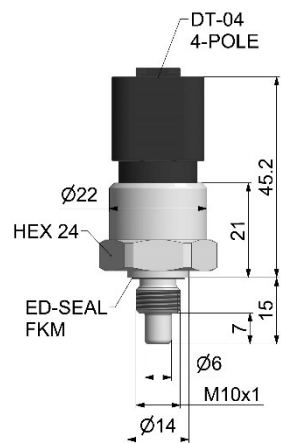

SCT03-007-X6-0D

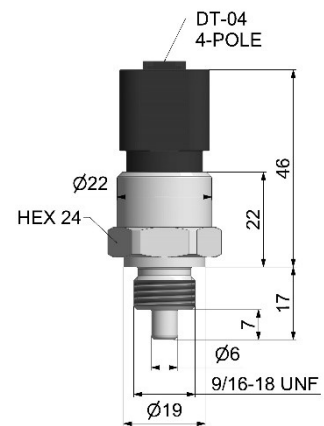

SCT03-007-X4-0J

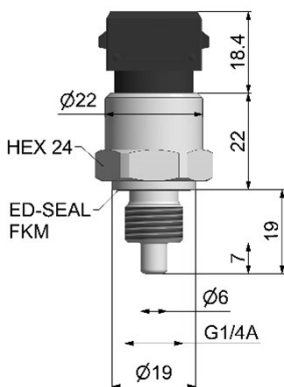

SCT03-007-XJ-0J

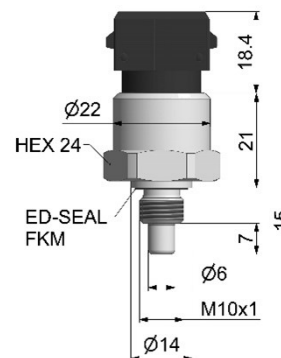

SCT03-007-X6-0J

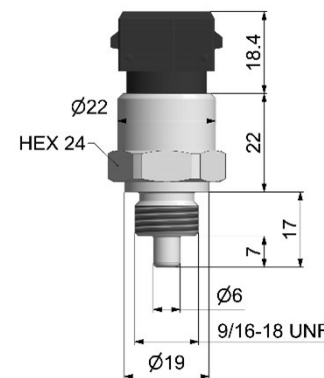

SCT03 temperature sensor

Order code

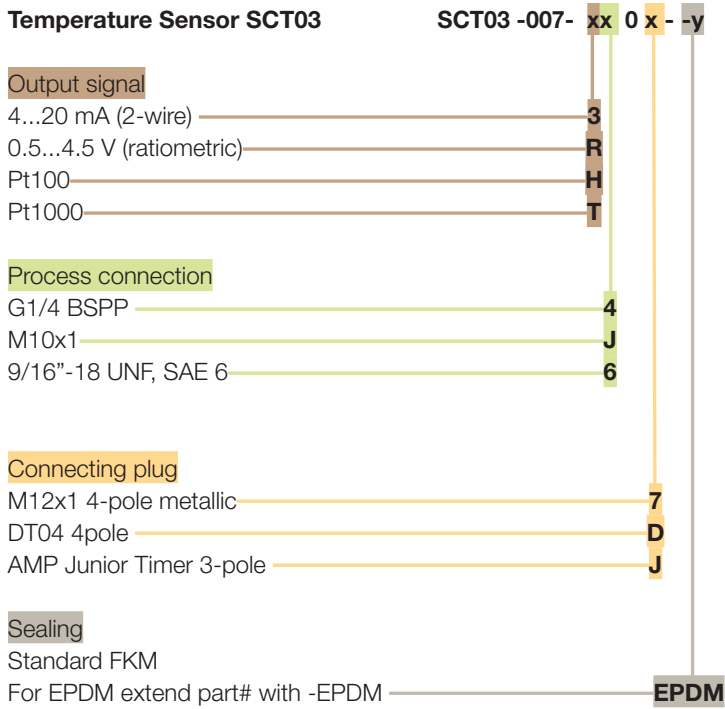

*1 Only in combination with 9/16-18UNF-6M / 59°

Volumetric flow rate sensors

Device features

- Different measurement techniques
 - Quick
 - Not dependent on viscosity
 - Without loss
- Many measurement ranges
- Analogue output signal
- M12 connecting plug
- 24 VDC



The flow sensors used in **SensoControl®** provide accurate volume flow information in hydraulic systems (e.g. in testing equipment).

The sensors deliver a output signal that is proportional to the volumetric flow rate for further processing to an electronic system. They are compatible with conventional, well-known standards.

- M12 connecting plug
- 24 VDC
- 0/4 to 20 mA

The volumetric flow rate can be easily displayed when using the **SCE-020** panel meter.



In order to meet the many different application requirements, three different measuring principles are available:

- **SCVF** geared counter
- **SCFT** turbine
- **SCQ** spring/piston

The volumetric flow rate sensors are used in control, regulation or monitoring systems where analogue signals are needed to capture the volume flow.

Volumetric flow rate sensors

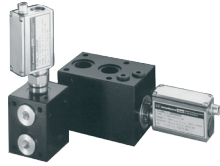
Overview

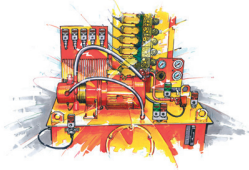
| | SCQ | SCFT | SCVF |
|----------------------|--|--|---|
| |  |  |  |
| Range of use | <p>For quick flow changes Measures in both directions</p> <ul style="list-style-type: none"> Response speed ≤ 2 ms Reverse operation Wide viscosity range Compact size Up to 420 bar (6092 psi) | <p>Low loss measuring of volume flow</p> <ul style="list-style-type: none"> Response speed ≤ 50 ms Many measurement ranges Low flow resistance Up to 800 l/min Up to 420 bar (6092 psi) | <p>Measures different substances Measures lower volume flows (leakage measurements)</p> <ul style="list-style-type: none"> Very wide measurement range Not dependent on viscosity Up to 400 bar (5802 psi) |
| Applications | <ul style="list-style-type: none"> Test rigs General machine construction Hydraulic plant construction | |  |
| Order code | SCQ-xxx-10-07 | SCFT-xxx-22-07 | SCVF-xxx-10-07 |
| Refer to page | 46-49 | 50-53 | 54-59 |

SCQ flow meter

Device features

- Measurement principle Spring/piston principle
- Response time ≤ 2 ms
- Measurement in both directions
- Wide viscosity range
- Compact design
- Withstands pressures up to 420 bar (6092 psi)

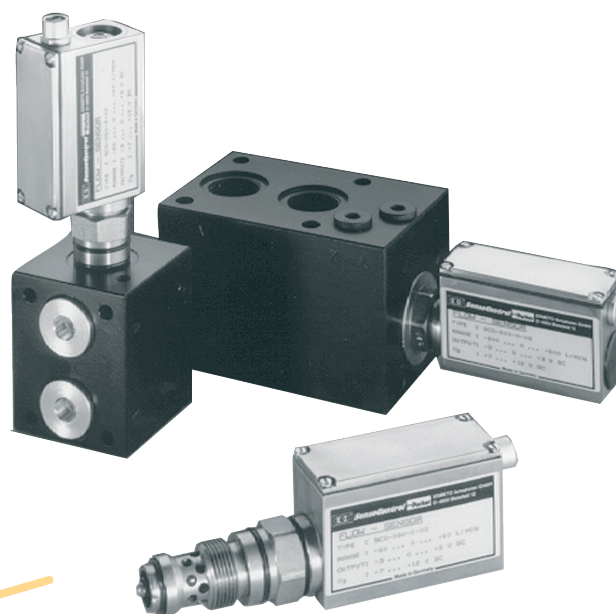

Function

The piston (K) is moved due to a flow from A to B or from B to A. In the idle state, the spring (F) and the piston (K) are in equilibrium. The delta (S) is proportional to the flow and is converted to a value through the built-in electronics. Through the change in direction of the piston (B to A), the flow direction can be indicated. (e.g. -45.8 l/min) The reaction time of the piston movement is less than 2 ms.

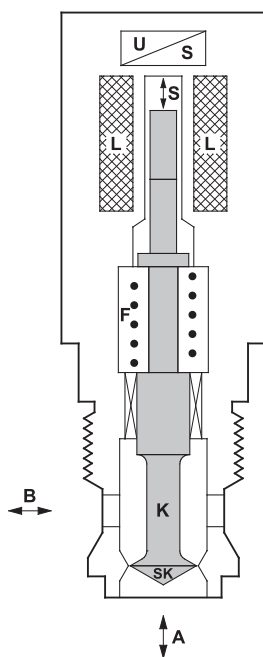

SCQ measurement principle

Application

When working with high-pressure hydraulics, it is very important to be able to quickly detect the flow rate.

Installation with a connection block permits the combined measurement of p, T and Q. Rapid assembly of the **SCQs** is achieved with an in-line adaptor for tube or hose installation. Use under extreme conditions (such as high load changes or rapid pressure increases) is possible because of the sturdy construction.

The **SCQ** is the perfect solution when recording highly dynamic volume flow changes. Rapid load changes, which can cause damage for example in valves and pumps, can be safely detected. Due to its unique measurement process, the **SCQ** can capture volume flow in both directions.

SCQ flow meter

Technical data

| SCQ- | 150 |
|----------------------|-------------------|
| Measuring range QN | -150...+150 l/min |
| Qmax | -165...+165 l/min |
| Substance connection | M42 (NG16) |
| Weight (g) | 1050 |

| Accuracy | |
|-------------------------------------|-----------------------------|
| Deviation from characteristic curve | ±2 % FS @ 46cSt. |
| Response time | 2 ms |
| Thermal drift | ±0.05 % FS/°C |
| Repeat accuracy | ± 0.5 % FS |
| Resistance to pressure | |
| Pressure range | 3...420 bar |
| Operating pressure P _n | 315 bar / (4569 psi) |
| Overload pressure P _{max} | 420 bar / (6092 psi) |
| Pressure drop ΔP (bar) @ (FS) | Refer to diagram |
| Material | |
| Housing | Steel |
| Seal | NBR |
| Parts in contact with substances | Steel, NBR |
| Ambient conditions | |
| Operating temperature | +10...+60 °C / (50...140°F) |
| Storage temperature | -20...80 °C / (-4...176°F) |
| Tmax Fluid | +80 °C / (176°F) |
| Filtration | 25 μm |

| Viscosity range | 15...100 cSt. |
|----------------------------|--|
| Protection degree | IP67 DIN EN 60529 |
| Electrical connection | |
| Plug | M12x1; 4-pole |
| Supply voltage | +18...+30 VDC |
| Current consumption | 40 mA |
| Output | 0...20 mA = -FS...+FS (10 mA = 0 l/min) |
| Load | ≤ 150 Ω |
| Signal noise | < 5 mV |
| EM compatibility | |
| Disturbance emissions | EN 61000-6-3 |
| Resistance to interference | EN 61000-6-2 |

Pin assignment

M12x1; 4-pole

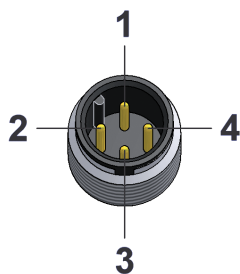

| PIN | Assignment |
|-----|----------------|
| 1 | V ₊ |
| 2 | Q signal |
| 3 | 0 V/GND |
| 4 | - |

SCQ flow meter

Screw plug hole and pressure-drop curve **SCQ-150**

30 Nm torque

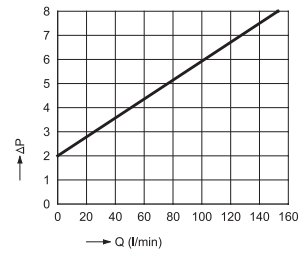
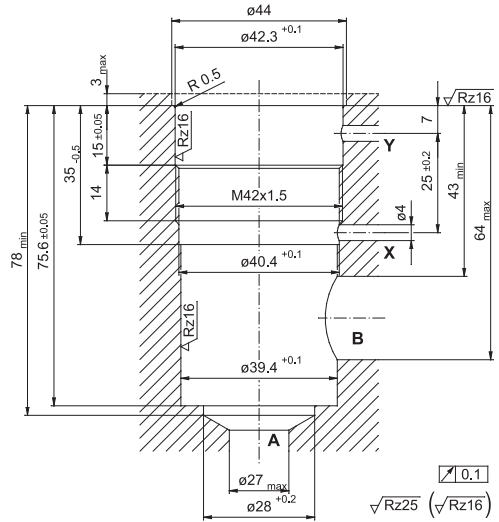
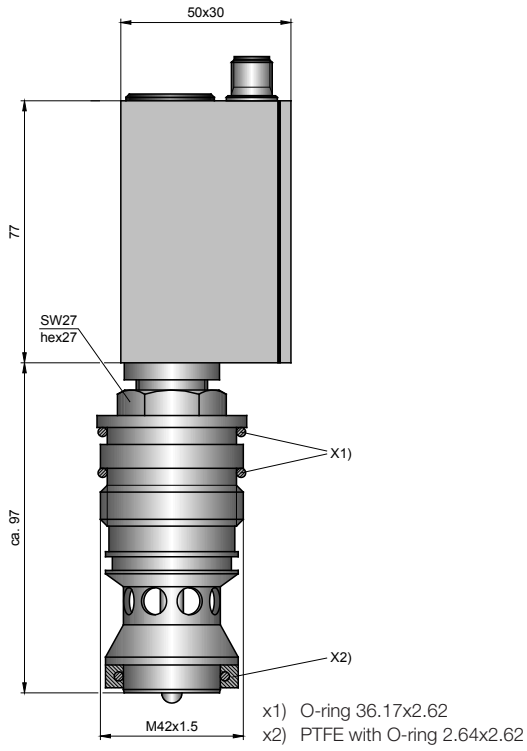

SCQ flow meter

SCAQ-GI-R1/2

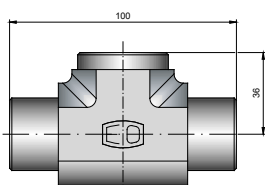

SCAQ-150

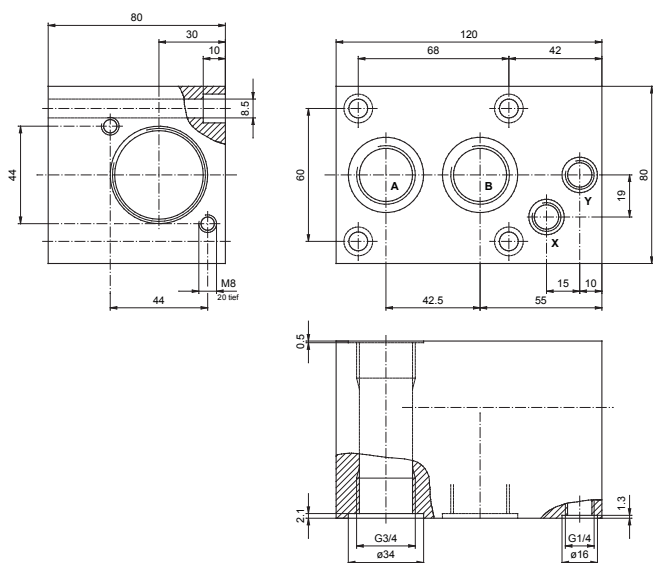

Order code

SCQ-150 (-150 to +150 l/min)

M12x1, 4-pole; connecting plug; IP67
0 to 20 mA; -150...+150 l/min

SCQ-150-10-07

Accessories SCQ-150

Connector block
G3/4 BSPP inner (A-B) and M42 inner
With screw plug:
M42 outer and
G3/4 BSPP outer (A-B)

SCAQ-150

Spare parts

Spacer ring for SCQ-060
Seal kit for SCQ-060
Seal kit for SCQ-150

SC-910

SC-911

SC-912

Connection cable and single plug

Connection cable, assembled

(open cable end)

SCK-400-xx-xx

Cable length (m)

| | |
|------|----|
| 2 m | 02 |
| 5 m | 05 |
| 10 m | 10 |

Connecting plug

| | |
|----------------------------|----|
| M12 cable jack; straight | 45 |
| M12 cable jack; 90° angled | 55 |

Single connector

M12 cable jack; straight
M12 cable jack; 90° angled

SCK-145

SCK-155

SCFT measurement turbine

Device features

- Measurement principle: Turbine
- Response speed ≤ 50 ms
- Measurement range from 1 to 800 l/min
- Low flow resistance
- Suitable for reverse operation
- Built-in pressure and temperature ports

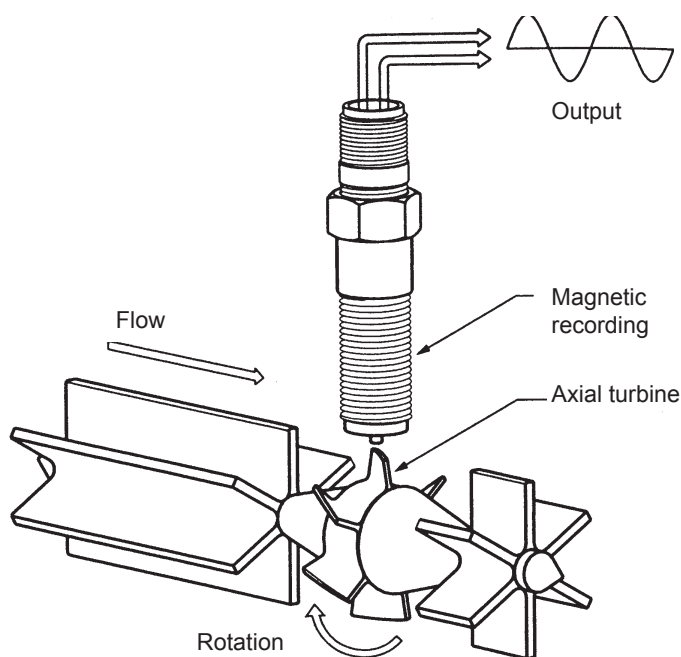

Function

The turbine wheel is driven by the oil flow. The generated frequencies are processed through the digital electronics and influences from the disturbing flow effects are compensated for. Because of the low flow resistance Q_R , the hydraulic circuit operates with very low losses.

Reverse operation is also possible because of the special vane (winged) design - so the turbine can be operated in both directions.

The turbine is fitted with an EMA-3 screw coupling for measuring pressure. Oil temperature can be measured directly in the oil flow of the turbine by connecting the temperature sensor (**SCT-150**). This provides all important measurements at the installation location.

Application

The **SCFT** is the ideal solution if the volumetric flow rate needs to be recorded loss-free across a wide flow range (up to 800 l/min.).

SCFT measurement turbine

Technical data

| SCFT- | 015 | 060 | 150 | 300 | 600 | 800 |
|--|----------------------|----------------------|-----------------------|---------------------|-----------------------|-----------------------|
| Flow measuring range Q _n (l/min) (US Gal/min) | 1...15 (0.25...4) | 3...60 (0.8...16) | 5...150 (1.3...40) | 8...300 (2...80) | 15...600 (4...160) | 20...800 (5...210) |
| Accuracy (± %) FS/IR @ 21cSt. | ± 1 % FS | ± 1 % IR | ± 1 % IR | ± 1 % IR | ± 1 % IR | ± 1 % IR |
| Operating pressure P _n bar / (psi) | 350 (5076) | 350 (5076) | 350 (5076) | 350 (5076) | 290 (4206) | 400 (5801) |
| Ports (A - B) | G1/2 BSPP | G3/4 BSPP | G3/4 BSPP | G1 BSPP | G1 1/4 BSPP | G1 7/8 UNF |
| Pressure drop ΔP (bar) @ (FS) | 1.5 | 1.5 | 1.5 | 4 | 4 | 5 |
| Weight (g) | 700 | 1600 | 1600 | 1700 | 2700 | 5000 |

FS = Full Scale
IR = Indicated Reading

| Accuracy | |
|------------------------------------|-----------------------------|
| Response time | 50 ms |
| Thermal drift | ±0.05 % FS/°C |
| Repeat accuracy | ± 0.5 % FS |
| Resistance to pressure | |
| Q _{max} (l/min) | Q _N x 1.1 |
| Overload pressure P _{max} | P _N x 1.2 |
| Material | |
| Housing | Aluminium |
| Seal | FKM |
| Parts in contact with substances | Aluminium, steel, FKM |
| Ambient conditions | |
| Ambient temperature | -10...+50 °C / (14...122°F) |
| Storage temperature | -20...+80 °C / (-4...176°F) |
| T _{max} Fluid | -20...+80 °C / (-4...176°F) |
| Filtration | 25 μm (10 μm for SCFT-015) |
| Viscosity range | 15...100 cSt. |
| Protection class | IP66 EN60529 |

| Ports | |
|--|--------------------------|
| Temperature measurement (SCT-150-14-07) | M10x1 OR |
| Pressure connection | EMA3 |
| Pressure (VSTI) | G1/4 BSPP |
| Electrical connection | |
| Plug | M12x1; 5-pole |
| Power supply V ₊ | 18...30 V |
| Output signal | 4...20 mA ± 0...FS l/min |
| Complete output current range | 0...21 mA |
| Current consumption | < 30 mA |
| Protection degree | IP66 EN60529 |

Pin assignment

M12x1; 5-pole

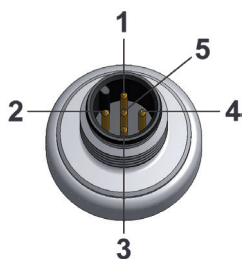

| PIN | Assignment |
|-----|----------------|
| 1 | V ₊ |
| 2 | n.c. |
| 3 | Q signal |
| 4 | n.c.* |
| 5 | 0 V / GND |

*n.c. = do not connect



SCFT measurement turbine

Volumetric flow rate sensors

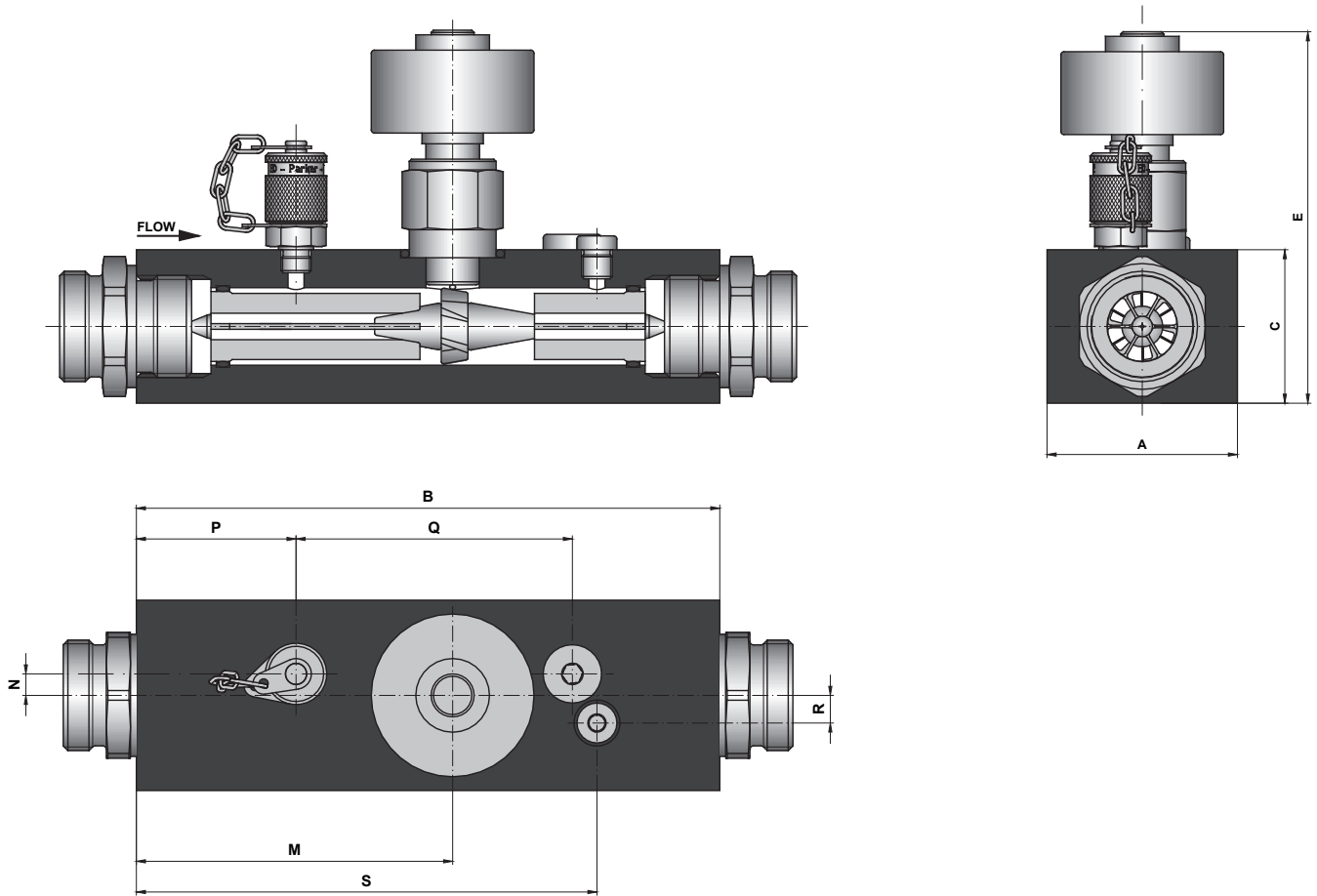

| # | SCFT-015 | SCFT-060 | SCFT-150 | SCFT-300 | SCFT-600 | SCFT-800 |
|---|----------|----------|----------|----------|----------|----------|
| A | 37 | 62 | 62 | 62 | 62 | 100 |
| B | 136 | 190 | 190 | 190 | 212 | 212 |
| C | 37 | 50 | 50 | 50 | 75 | 75 |
| E | 115 | 130 | 130 | 134 | 149 | 152 |
| M | 70 | 103 | 103 | 103 | 127 | 126 |
| N | 0 | 5 | 5 | 7 | 9 | 10 |
| P | 25 | 50 | 50 | 52 | 62 | 60 |
| Q | N/A | 92 | 92 | 90 | 106 | 104 |
| R | 0 | 5 | 5 | 9 | 11 | 10 |
| S | 115 | 157 | 157 | 150 | 168 | 181 |

SCFT measurement turbine

Order code

SCFT

M12x1, 5-pole; connecting plug; IP66

4...20 mA (3-wire)

BSPP:

| | |
|----------------|-----------------------|
| 1...15 l/min | SCFT-015-22-07 |
| 3...60 l/min | SCFT-060-22-07 |
| 5...150 l/min | SCFT-150-22-07 |
| 8...300 l/min | SCFT-300-22-07 |
| 15...600 l/min | SCFT-600-22-07 |
| 20...800 l/min | SCFT-800-22-07 |

UNF:

| | |
|---------------------|------------------------|
| 0.25...4 US Gal/min | SCFT-004G-2U-07 |
| 0.8...16 US Gal/min | SCFT-016G-2U-07 |
| 1.3...40 US Gal/min | SCFT-150G-2U-07 |
| 2...80 US Gal/min | SCFT-080G-2U-07 |
| 4...160 US Gal/min | SCFT-160G-2U-07 |
| 5...210 US Gal/min | SCFT-210G-2U-07 |

Connection cable and single plug

Connection cable, assembled

(open cable end)

SCK-400-xx-xx

Cable length (m)

| | |
|------|-----------|
| 2 m | 02 |
| 5 m | 05 |
| 10 m | 10 |

Connecting plug

| | |
|----------------------------|-----------|
| M12 cable jack; straight | 45 |
| M12 cable jack; 90° angled | 55 |

Single connector

| | |
|----------------------------|----------------|
| M12 cable jack; straight | SCK-145 |
| M12 cable jack; 90° angled | SCK-155 |

SCVF volume counter

Device features

- Measurement principle: Volume/geared counter
- Eight measurement ranges from 0.01 - 2 to 1 - 300 l/min
- Accuracy $\pm 0.5\%$ FS
- Withstands pressures up to 400 bar (5802 psi)
- High viscosity range
- Low noise
- Exact flow rate measurement over a wide viscosity range
- Versatile usage for different substances

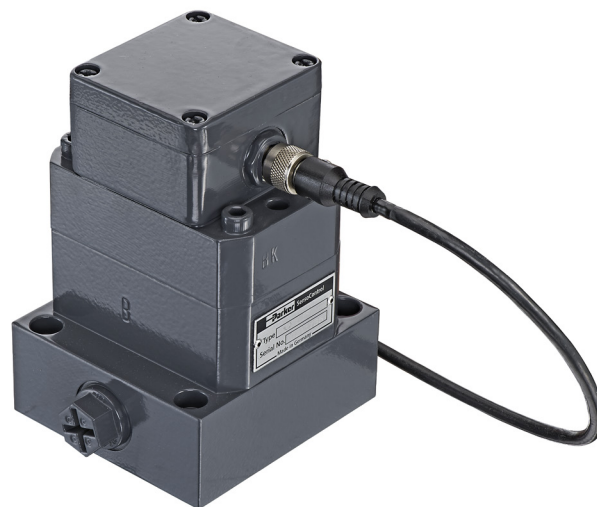

Gear counter for highly accurate flow rate measurements in hydraulic systems

Function

The SCVF geared counter functions as a volume flow meter. A very precisely crafted pair of geared wheels is driven by the fluid flow.

The SCVF works over a wide viscosity range. Different seals permit usage in many different applications.

Applications

Due to the wide viscosity range, any liquid can be measured that can be pumped and has a certain degree of lubricating capability.

- Brake fluid (EPDM seal)
- Skydrol
- Mineral oils
- Hydraulic oil and
- Grease

The SCVF is the ideal solution when carrying out precise flow rate measurements over a wide viscosity range.

SCVF volume counter

Technical data

| SCVF- | 002 | 004 | 015 | 040 | 060 | 080 | 150 | 300 |
|--|------------|------------|------------|------------|------------|------------|------------|------------|
| Flow measuring range (l/min) | 0.01...2.0 | 0.02...4.0 | 0.2...15 | 0.4...40 | 0.4...60 | 0.4...80 | 0.6...150 | 1.0...300 |
| Pressure range P _N bar / (psi) | 400 (5802) | 315 (4569) | 400 (5802) | 400 (5802) | 400 (5802) | 400 (5802) | 315 (4569) | 315 (4569) |
| Overload pressure P _O bar / (psi) | 480 (6962) | 400 (5802) | 480 (6962) | 480 (6962) | 480 (6962) | 480 (6962) | 350 (5076) | 350 (5076) |
| Connection | G3/8 BSPP | G3/8 BSPP | G3/8 BSPP | G1/2 BSPP | G1/2 BSPP | G1/2 BSPP | G1 BSPP | G1 BSPP |
| Sound level dB (A) | < 60 | < 60 | < 60 | < 70 | < 70 | < 70 | < 70 | < 72 |
| Resolution (pulses / litre) | 40,000 | 25,000 | 4082 | 965 | 965 | 965 | 333.33 | 191 |

Accuracy

| | |
|-------------------------------------|--|
| Deviation from characteristic curve | ± 0.3 % FS ≥ 20 cSt. ± 0.5 % FS ≥ 20 cSt. |
| Response time | < 10 ms |
| Repeat accuracy | 0.01 % FS |
| Substance *) | Hydraulic oil (25 micron filter) |

Material

| | |
|---------|--|
| | Material 1.7139 Contains no non-ferrous metal or silicone |
| Housing | Steel |
| Seal | FKM EPDM on request |

Ambient conditions

| | |
|---------------------|------------------------------|
| Ambient temperature | 0...+55 °C / (32...131°F) |
| Storage temperature | -25...+85 °C / (-13...185°F) |
| Fluid temperature | -30...120 °C / (-22...148°F) |
| Viscosity range | Refer to diagram p. 44 |
| Protection degree | IP65 DIN EN 60529 |

FS = Full scale value

*) When using other substances, please state the viscosity range and the type of seals. (Attach the data sheet of the substance if possible)

Electrical connection

| | |
|-----------------------------|--------------------------|
| Plug | M12x1; 4-pole |
| Power supply V ₊ | +18...+30 VDC |
| Current consumption | < 28 mA |
| Output signal | 0...20 mA ± 0...FS l/min |
| Load | ≤ 150 Ω |

EM compatibility

| | |
|----------------------------|--------------|
| Disturbance emissions | EN 61000-6-3 |
| Resistance to interference | EN 61000-6-2 |

Pin assignment

M12x1; 4-pole

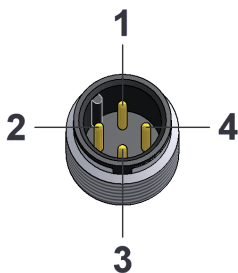

| PIN | Assignment |
|-----|----------------|
| 1 | V ₊ |
| 2 | Q-signal |
| 3 | 0 V / GND |
| 4 | - |

SCVF volume counter

Technical data

SCVF-002 Δp - Viscosity

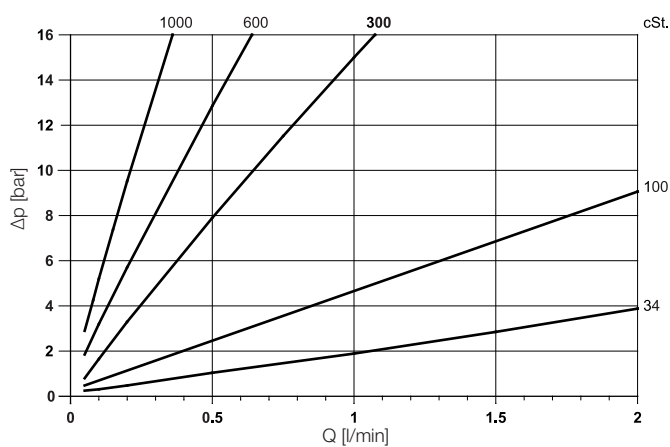

SCVF-004 Δp - Viscosity

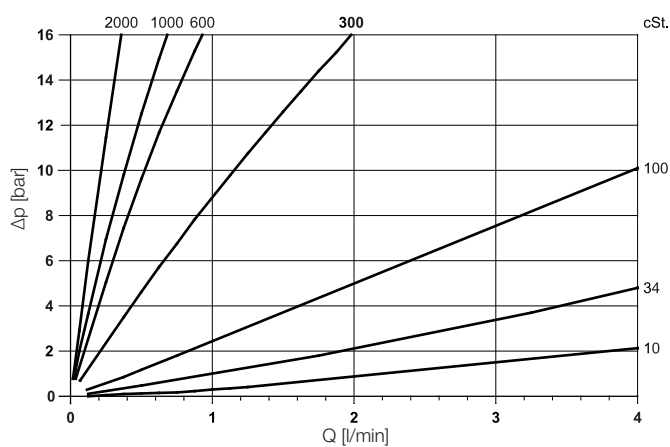

SCVF-015 Δp - Viscosity

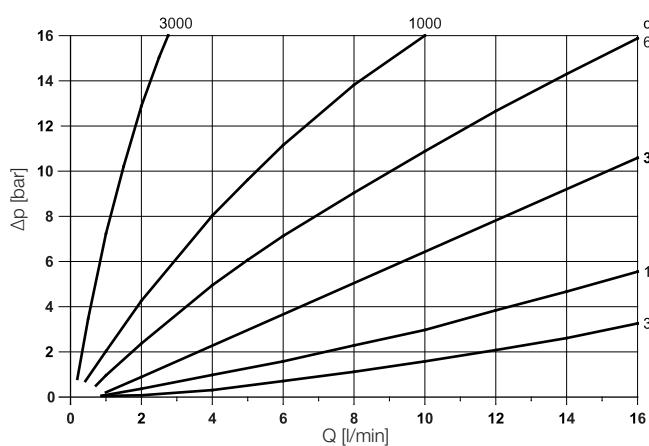

SCVF-040/060/080 Δp - Viscosity

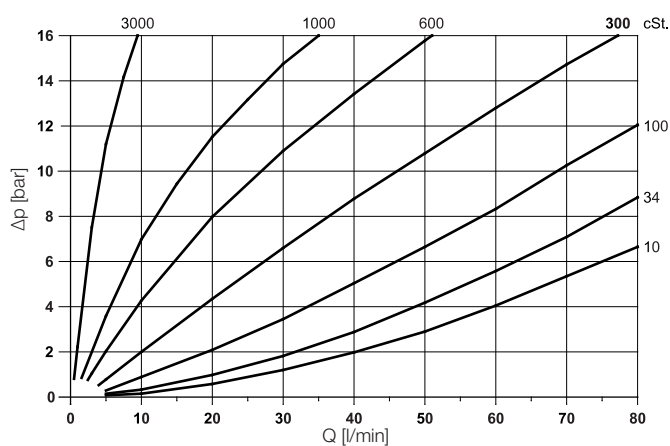

SCVF-150 Δp - Viscosity

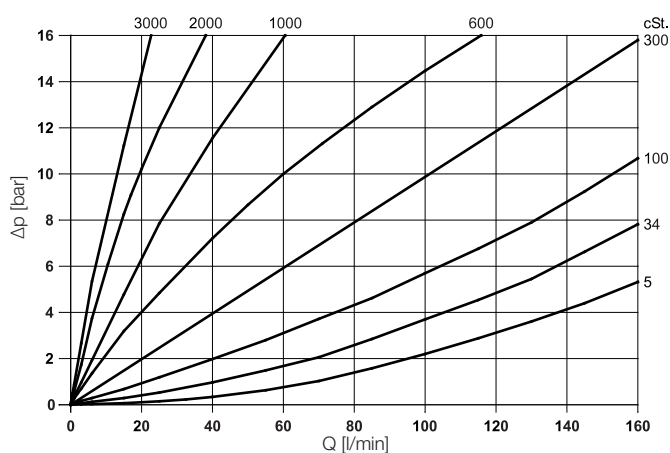

SCVF-300 Δp - Viscosity

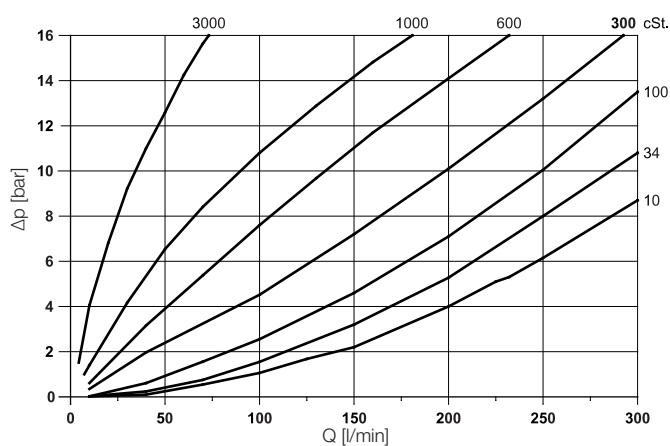

Δp = pressure loss



SCVF volume counter

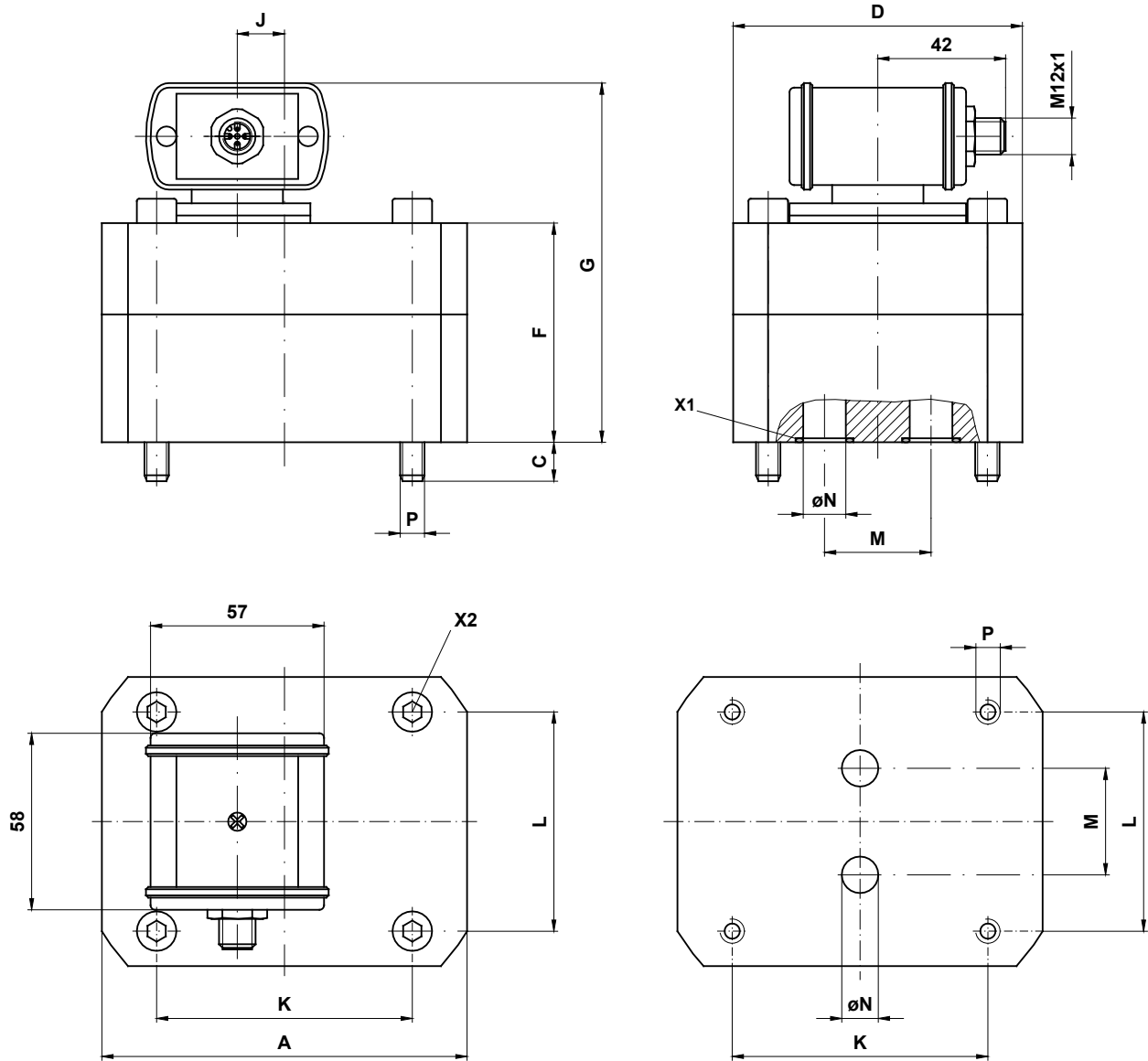

| Type | Weight [kg] | Torque [Nm] | A | C | D | F | G | J | K | L | M | øN | P |
|----------|-------------|-------------|-----|----|-----|-----|-----|------|----|----|----|-----|-----|
| SCVF-002 | 1.8 | 14 | 85 | 10 | 60 | 50 | 87 | - | 70 | 40 | 20 | 6.5 | M6 |
| SCVF-004 | 2 | 14 | 85 | 9 | 60 | 56 | | - | 70 | 40 | 20 | 6.5 | M6 |
| SCVF-015 | 2 | 14 | 85 | 13 | 60 | 57 | 94 | - | 70 | 40 | 20 | 9 | M6 |
| SCVF-040 | 5.2 | 35 | 120 | 13 | 95 | 72 | 109 | 10.5 | 84 | 72 | 35 | 16 | M8 |
| SCVF-060 | | | | | | | | | | | | | |
| SCVF-080 | | | | | | | | | | | | | |
| SCVF-150 | 9 | 120 | 170 | 18 | 120 | 89 | 140 | 46.5 | 46 | 95 | 50 | 25 | M12 |
| SCVF-300 | 13 | 120 | 170 | 22 | 120 | 105 | 142 | 40 | 46 | 95 | 50 | 25 | M12 |

All measurements in mm

SCVF volume counter

Dimensioned drawings connection plate

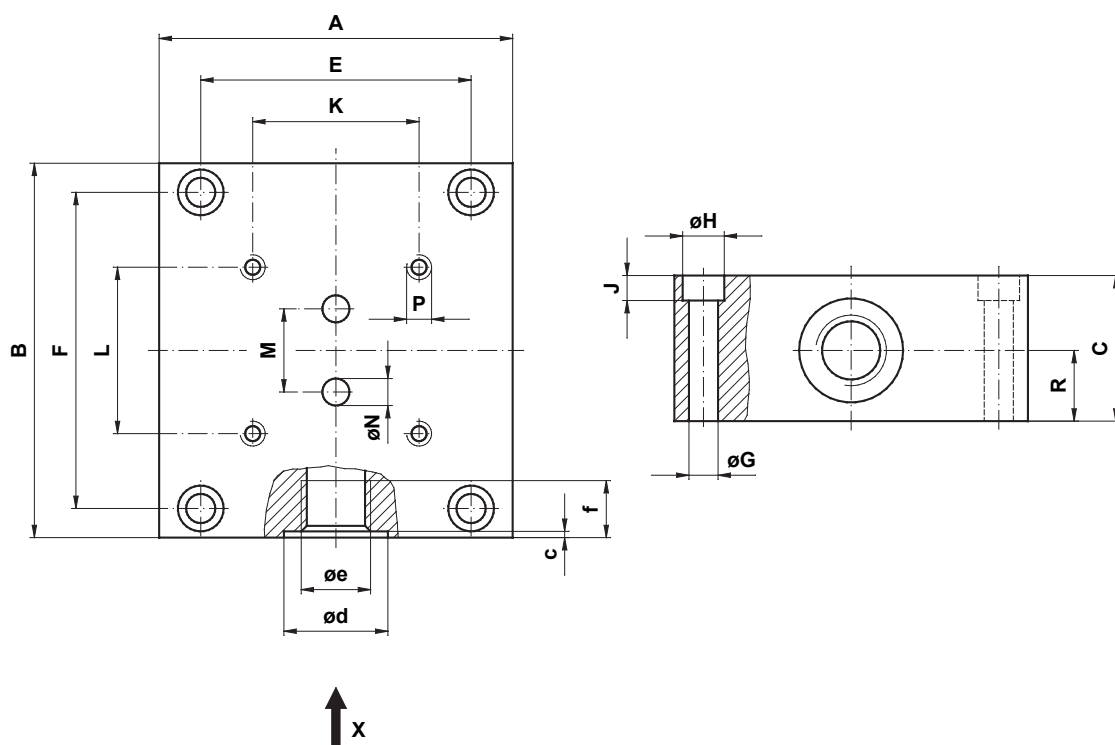

| Type | kg | A | B | C | E | F | øG | øH | J | K | L | M | øN | P | R | c | ød | øe BSPP | f |
|----------------------------------|-----|-----|-----|----|-----|-----|----|----|---|----|----|----|-----|------------|------|-----|----|------------|----|
| SCVF-002 SCVF-004 SCVF-015 | 1.8 | 85 | 90 | 35 | 65 | 76 | 7 | 11 | 7 | 70 | 40 | 20 | 6.5 | M6/t = 14 | 17 | 0.7 | 25 | G3/8 | 13 |
| SCVF-040 SCVF-060 SCVF-080 | 2.9 | 100 | 120 | 37 | 80 | 106 | 7 | 11 | 7 | 84 | 72 | 35 | 12 | M8/t = 18 | 17.5 | 0.7 | 29 | G 1/2 | 15 |
| SCVF-150 SCVF-300 | 14 | 160 | 165 | 80 | 140 | 145 | 9 | 15 | 9 | 46 | 95 | 50 | 25 | M12/t = 24 | 28 | 1 | 42 | G1 | 19 |

All measurements in mm

SCVF volume counter

Order code

SCVF

M12x1, 4-pole; connecting plug; IP65; incl. connection plate

0...20 mA

0.01...2 l/min

SCVF-002-10-07

0.02...4 l/min

SCVF-004-10-07

0.2...15 l/min

SCVF-015-10-07

0.4...40 l/min

SCVF-040-10-07

0.4...60 l/min

SCVF-060-10-07

0.4...80 l/min

SCVF-080-10-07

0.6...150 l/min

SCVF-150-10-07

1...300 l/min

SCVF-300-10-07

Connection cable and single plug

Connection cable, assembled

SCK-400-xx-xx

(open cable end)

Cable length (m)

2 m

02

5 m

05

10 m

10

Connecting plug

M12 cable jack; straight

45

M12 cable jack; 90° angled

55

Single connector

M12 cable jack; straight

SCK-145

M12 cable jack; 90° angled

SCK-155

I/O-Link Switch Family

Device features

- Large display
- Freely adjustable
- Rugged metal construction
- Compact size
- Long-term stability
- Dependable
- Immune to interference



This switch is used in control, regulation or monitoring systems where switching signals or analogue signals are used or a display is required.

The switch can replace the following:

- Mechanical switches
- Mechanical displays
(pressure gauges, thermometers, inspection glass)
- Sensors

All the above mentioned functions can be combined in one device.

All switch devices have a compact and pivoting metal housing so that they can be mounted optimally under adverse installation conditions. The large display can always be perfectly positioned so that it is easy to read even at longer distances.

Both of the switching outputs can be set individually either as NO or NC. They also both have hysteresis and the window functions. Therefore the on and off switching values as well as delay times (attenuation) for each of the switching points can be chosen freely.

Thanks to these easy switching functions, intelligent adjustments can be set which are normally not possible using a mechanical switch. Therefore, many switches can be replaced with one product of the I/O-Link switch family.

The switches offer good practical characteristics combined with diverse mounting and setting options.

Because of its compact design, long lifespan and high functionality, this controller is ideal for the permanent series use in hydraulic and pneumatic applications.

I/O-Link Switch Family

Overview

SCPSDI



SCTSDI (Modular)



Range of use Pressure display and monitoring

- Compact size
- Resistant to pressure peaks
- Resistant to shock and vibration
- IO-Link interface

Temperature display and monitoring

- Temperature display
- Fixed level contacts

Applications

- Test benches
- Processing equipment
- Conveying and lifting equipment
- General machine construction
- Pneumatic plant construction
- Hydraulic plant construction

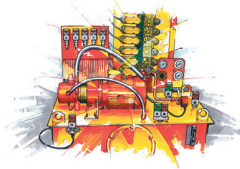

Order code SCPSDI-xxx-x4-xx

SCTSDI-150-1T-05

Refer to page 67-70

75-79

SCLSDI



SCLTSDI



SCTSDI



Range of use Level indication and monitoring

- Level display
- Practical monitoring with window function
- Continuous level measurement

Level/temperature display and monitoring

- Level display
- Temperature display
- Continuous level measurement
- One bore hole

Temperature display and monitoring

- Temperature display
- Practical monitoring with window function
- Continuous temperature measurement

Applications

- Test benches
- Processing equipment
- Conveying and lifting equipment
- General machine construction
- Pneumatic plant construction
- Hydraulic plant construction

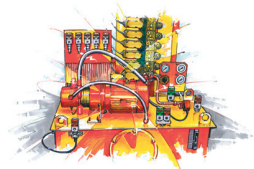

Order code SCLSDI-xxx-x0-xx

SCLTSDI-xxx-x0-xx

SCTSDI-xxx-x0-xx

Refer to page 80-83

84-87

71-74

SCPSDI Pressure Switch

Device features

Display

- Large Display
- 2-color switching status display
- Reversal of viewing direction by 180°
- Beveled for better readability
- Units in bar, MPa and psi

Easy to use

- 3 tactile buttons
- VDMA-Menu navigation

Outputsignal

- IO-Link interface
- Stable metallic M12x1 thread
- Pin assignment according to VDMA
- Can be selected between switching output, current output and voltage output

Measuring element

- Pressure range up to 600 bar possible
- High compressive strength
- High accuracy up to 0,5% FS
- Long-term stable measuring cell

Thread

- G1/4 internal and external thread
- Stainless steel 17-4PH = /1.4542
- Broad media compatibility

Housing

- Metallic housing
- High quality surface
- 240° rotatable
- IP67 protection
- Increased temperature range between -40°C up to +85°C



SCPSDI Pressure Switch

Technical data

| SCPSDI- | 004 | 010 | 016 | 060 | 100 | 250 | 400 | 600 |
|---------------------------------------|--------|---------|---------|--------|---------|---------|---------|---------|
| Pressure range P_n | -1...4 | -1...10 | -1...16 | 0...60 | 0...100 | 0...250 | 0...400 | 0...600 |
| Overload pressure P_{max} | 50 | 50 | 50 | 500 | 500 | 800 | 1200 | 1200 |
| Burst pressure P_{burst} | 1500 | 1500 | 1500 | 2500 | 2500 | 3000 | 3500 | 3500 |
| Display resolution | 0,001 | 0,01 | 0,01 | 0,01 | 0,1 | 0,1 | 0,1 | 0,1 |
| Min. adjustable difference SP and rSP | 0,01 | 0,01 | 0,01 | 0,1 | 0,1 | 0,1 | 1 | 1 |

All units in bar

Process connection

| | |
|--------------------|-----------------------------|
| Process connection | G1/4 BSPP Internal/External |
| Tightening torque | 35 Nm |

Parts in contact with media

| | |
|--------------------|------------------------------------|
| Internal thread | Stainless Steel: 17-4PH = / 1.4542 |
| External thread | Stainless Steel: 17-4PH = / 1.4542 |
| | Sealing: ED FKM SH75 |
| Sampling rate | ≤3 ms |
| Medium temperature | -40...+85 °C |
| Switching cycles | ≥10 Mio. |

Output variables

| | |
|----------------|-----------------------------------|
| Current output | 0..20mA or 4..20mA (programmable) |
| Voltage output | 0..10V |

Switching point

| | |
|-------------------------|---|
| Switching current: | max. 200 mA |
| Short circuit current: | 400mA (short term), short circuit proof |
| Switching voltage: | Supply voltage - 0,5 VDC |
| Execution: | PNP/ NPN (programmable) |
| Max switching frequency | 250 Hz |

Accuracy

| | |
|---------------|----------|
| @ 25°C | ±0,5% FS |
| @ -20...+85°C | ±1,5% FS |

Display accuracy

| | |
|---------------|-------------------|
| @ 25°C | ±0,5% FS ±1 Digit |
| @ -20...+85°C | ±1,5% FS ±1 Digit |

Response speed

| | |
|------------------|-------|
| Switching output | ≤3 ms |
| Analogue output | ≤3 ms |

Electrical connection

| | |
|-----------------------------|---------------------------|
| Supply voltage V_+ | 18...30 VDC |
| Connector | M12x1; 4pol / M12x1; 5pol |
| Short circuit protection | Yes |
| Reverse polarity protection | Yes |
| Overload protection | Yes |
| Overvoltage | 50 V |
| Current consumption | <40 mA @24V |
| Inrush current | <100 mA @24V |

IO-Link

| | |
|-----------------------|---|
| Profile: | Smart Sensor Profile 2nd Edition V1.1.2 |
| Process Cyklustime | 4 ms |
| SIO-Mode | Yes |
| SIO-Mod | A |
| Process data analogue | 2 Byte Process data 1 Byte Scaling factor |
| Process data binary | 1 Byte |
| SDCI Standard | IEC 61131-9 |
| Vendor ID | 271 (dec) / 10f (hex) |
| Device IODD | https://parker.com/ |

SCPSDI Pressure Switch

Technical data

| Housing | |
|--------------------------|--|
| Rotatability | >240° |
| Readability display | Reversal of viewing direction by 180° (programmable) |
| Display | 7-Segment-LED (4-digit) |
| | 2-color switching status display (red/yellow) |
| | Digit height : 8 mm |
| Buttons | 3 tactile buttons for up, down, enter |
| Material | |
| Housing | Zinc die-cast (bright nickel-plated) |
| Display cover | Polyester Autotex V207 |
| Protection class | IP67 |
| Weight | 150 g |
| Environmental conditions | |
| Ambient temperature | -40...+85 °C |
| Operating temperature | -40...+85 °C |
| Storage temperature | -40...+85 °C |
| Vibration resistance | DIN EN 60068-2-6, 20 g |
| Shock resistance | DIN EN 60068-2-27, 50 g |

| EM compatibility | |
|---|----------------------|
| Immunity to interference | |
| Emission of interference | EN 55011 |
| ESD | EN 61000-4-2 |
| high-frequency electro-magnetic fields | EN 61000-4-3 |
| fast transient electrical disturbances | EN 61000-4-4 |
| Conducted disturbances induced by high-frequency fields | EN 61000-4-6 |
| General | |
| MTTFd | >100 Jahre |
| RoHS-Conformity | 2011/65/EU, 2024/232 |

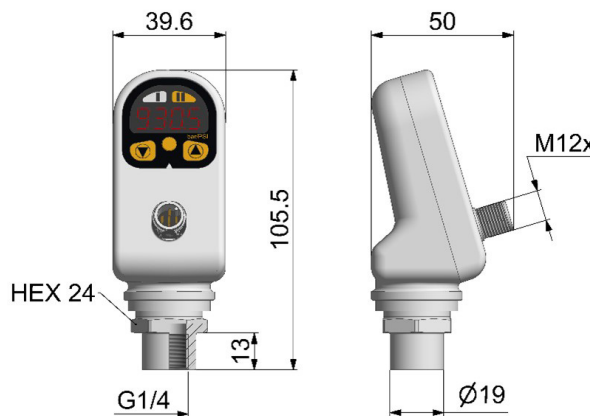
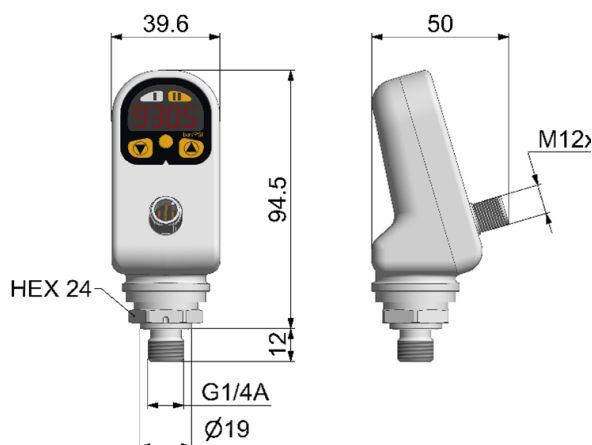

SCPSDI Pressure Switch

Order code

Digital PressureSwitch SCPSDI

2 switching points; no analogue output SCPSDI-xxx - 04 - x7
M12x1 connector; 4-Pin

1 switching point; with current output SCPSDI-xxx - 14 - x7
M12x1 connector; 4-Pin

2 switching points; with current output or voltage output SCPSDI-xxx - x4 - x5
M12x1 connector; 5-Pin

Pressure range

| | |
|---------|-----|
| 004 bar | 004 |
| 010 bar | 010 |
| 016 bar | 016 |
| 025 bar | 025 |
| 060 bar | 060 |
| 100 bar | 100 |
| 250 bar | 250 |
| 400 bar | 400 |
| 600 bar | 600 |

Analogue output

| | |
|---------------------|---|
| No analogue output | 0 |
| 0..20 mA / 4..20 mA | 1 |
| 0..10 V | 4 |

Version

| | |
|---------------------------|---|
| G1/4 BSPP External thread | 1 |
| G1/4 BSPP Internal thread | 2 |

Accessory

Securing clamp
Reducing adapter M22x1,5
Reducing adapter G1/2 BSPP
Attenuation adapter

SCSD-S24
RI22X1.5EDX1/4CF
SCA-1/4-ED-1/2-ED
SCA-1/4EDX1/4-D

Order example

SCPSDI-100-04-27

Pressure range 100 bar
2 switching points
G1/4 BSPP Internal thread
M12 Connector 4-Pin

SCPSDI-004-44-15

Pressure range 4 bar
2 switching points
1 analogue output 0..10V
G1/4 BSPP External thread
M12 Connector 5-Pin

Connection cable and single plug

Connection cable, assembled SCK-400 - xx - xx
(open cable end)

Cable length (m)

| | |
|------|----|
| 2 m | 02 |
| 5 m | 05 |
| 10 m | 10 |

Connector

| | |
|---------------------------|----|
| M12 cable jack; straight | 45 |
| 12 cable jack; 90° angled | 55 |

Single connector

| | |
|----------------------------|----------------|
| M12 cable jack; straight | SCK-145 |
| M12 cable jack; 90° angled | SCK-155 |

Connection

| PIN | Assignment SCPSDI-xxx-x4-x7 |
|-----|-----------------------------|
| 1 | V ₊ |
| 2 | Analogue out |
| 3 | 0 V/GND |
| 4 | S1 out / IO-Link |

| PIN | Assignment SCPSDI-xxx-04-x7 |
|-----|-----------------------------|
| 1 | V ₊ |
| 2 | S2 out |
| 3 | 0 V/GND |
| 4 | S1 out / IO-Link |

| PIN | Assignment SCPSDI-xxx-x4-x5 |
|-----|-----------------------------|
| 1 | V ₊ |
| 2 | S2 out |
| 3 | 0 V/GND |
| 4 | S1 out / IO-Link |
| 5 | Analogue out |



SCTSDI Temperature Switch

Device features

Display

- Large displays for temperature
- 2-color switching status display
- Reversal of viewing direction by 180°
- Bevelled for better readability
- Units in °C and °F

Easy to use

- 3 tactile buttons
- VDMA-Menu navigation

Outputsignal

- IO-Link interface
- Stable metallic M12x1 thread
- Pin assignment according to VDMA
- With 2 switching outputs and switchable current output between 0..20 and 4..20mA

Housing

- Metallic housing
- High quality surface
- 240° rotatable
- IP67 protection

Measuring element

- Fixed PT1000 element
- Measuring range between -20°C to 85°C

Temperature probe

- Temperature probe in following length 250, 370 and 520mm
- High accuracy up to 0,35% FS
- Long-term stable measuring probe

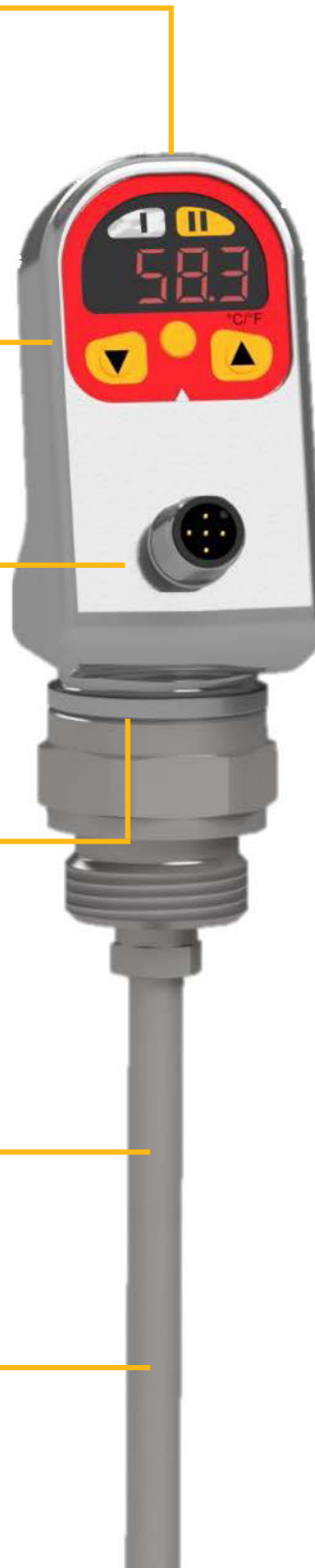

SCTSDI Temperature Switch

Technical data

| Ordercode temperature switch | SCTSDI-XXX-10-05 | | |
|---------------------------------------|------------------|-----|-----|
| Measuring range temperature | -20... 85 | | |
| Length (xxx in mm) | 250 | 370 | 520 |
| Lowest Reset point RSP | -20 | | |
| Highest Switching Point SP | 85 | | |
| Display resolution | 0,1 | | |
| Min. adjustable difference SP and rSP | 1 | | |

All units in bar

| Process connection | |
|--------------------|---------------|
| Process connection | G3/4 external |
| Tightening torque | 105 Nm |

| Output variables | |
|------------------|---------------------------------|
| Strom | 0..20mA or 4..20mA (switchable) |

| Switching point | |
|-------------------------|---|
| Switching current | max. 200 mA |
| Short circuit current | 400mA (short term), short circuit proof |
| Switching voltage | Supply voltage - 0,5 VDC |
| Execution | PNP/ NPN (programmable) |
| Max switching frequency | 250 Hz |

| Accuracy (temperature) | |
|------------------------|--------------------|
| @ 25°C | ±0,35% FS ±1 Digit |
| @ -20..+150°C | ±1,5% FS ±1 Digit |
| Response speed | |
| Switching output | ≤3 ms |
| Analogue output | ≤3 ms |
| Sample rate | ≤3 ms |

| Electrical connection | |
|-------------------------------|--------------|
| Supply voltage V ₊ | 18...30 VDC |
| Connector | M12x1; 5pin |
| Short circuit protection | Yes |
| Reverse polarity protection | Yes |
| Overload protection | Yes |
| Overvoltage | 50 V |
| Current consumption | <40 mA @24V |
| Inrush current | <100 mA @24V |

| IO-Link | |
|-----------------------|---|
| Profile | Smart Sensor Profile 2nd Edition V1.1.2 |
| Prozess Zykluszeit | 4 ms |
| SIO-Mode | Yes |
| Master port type | A |
| Process data analogue | 2 Byte Process data 1 Byte Scaling factor |
| Process data binary | 1 Byte |
| SDCI Standard | IEC 61131-9 |
| Vendor ID | 271 (dec) / 10f (hex) |
| Device IODD | https://parker.com/ |

SCTSDI Temperature Switch

Technical data

| Housing | |
|---------------------|--|
| Rotatability | >240° |
| Readability display | Reversal of viewing direction by 180° (programmable) |
| Display | 7-Segment-LED (4-digit) |
| | 2-color switching status display (red/yellow) |
| | Digit height : 8 mm |
| Buttons | 3 tactile buttons for up, down, enter |
| Material | |
| Housing | Zinc die-cast (bright nickel-plated) |
| Display cover | Polyester Autotex V207 |
| Protection class | IP67 |
| Weight | 300 g |
| General | |
| MTTFd | >100 years |
| RoHS-Conformity | 2011/65/EU, 2024/232 |

| EM compatibility | |
|---|------------------------|
| Immunity to interference | |
| Emission of interference | EN 55011 |
| ESD | EN 61000-4-2 |
| high-frequency electromagnetic fields | EN 61000-4-3 |
| fast transient electrical disturbances | EN 61000-4-4 |
| Conducted disturbances induced by high-frequency fields | EN 61000-4-6 |
| Environmental conditions | |
| Ambient temperature | -20...+85 °C |
| Operating temperature | -20...+85 °C |
| Storage temperature | -40...+85 °C |
| Medium temperature | -20...+85 °C |
| Vibration resistance | DIN EN 60068-2-6, 20 g |
| Shock resistance | DIN EN 60068-2-27, 50g |

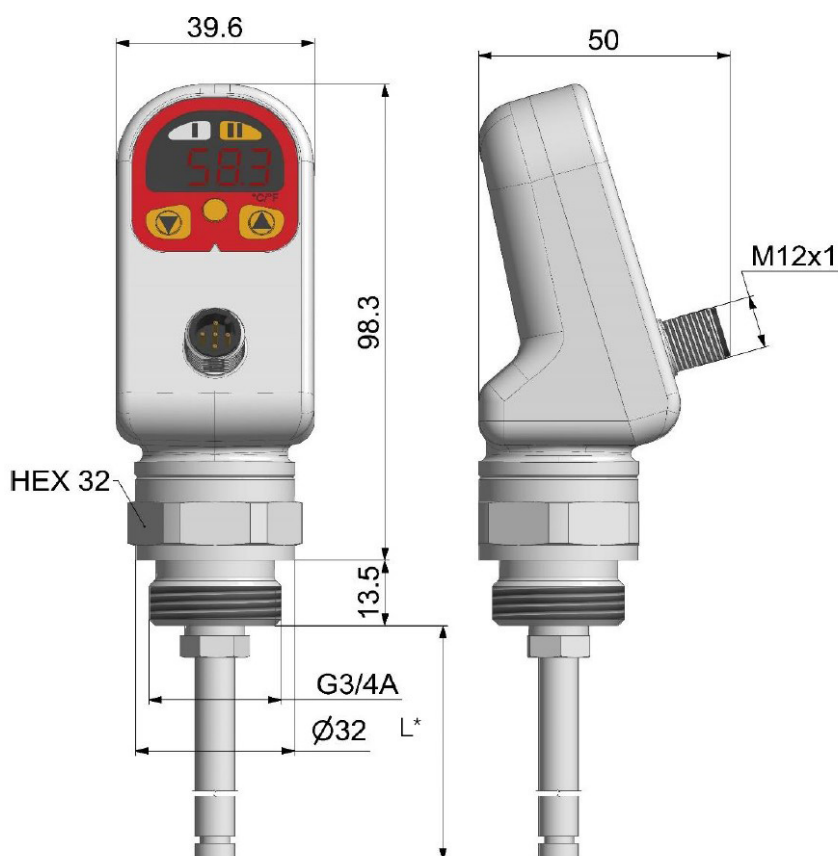

L^* = Probelength

SCTSDI Temperature Switch

Order code

SCTSDI Digital Temp Switch — **SCTSDI-250-10-05**

Probelength 250 mm

2 switching points; with current output

M12x1 connector; 5-Pin

SCTSDI Digital Temp Switch — **SCTSDI-370-10-05**

Probelength 370 mm

2 switching points; with current output

M12x1 connector; 5-Pin

SCTSDI Digital Temp Switch — **SCTSDI-520-10-05**

Probelength 520 mm

2 switching points; with current output

M12x1 connector; 5-Pin

| PIN | SCxSDI-xxx-x4-x5 |
|-----|------------------|
| 1 | V+ |
| 2 | S2 out |
| 3 | 0 V/GND |
| 4 | S1 out / IO-Link |
| 5 | Analogue out |

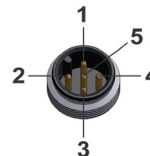

Accessories

Securing clamp

SCSD-S24

Reducing adapter M22x1,5

RI22X1.5EDX1/4CF

Reducing adapter G1/2 BSPP

RI1/2EDX1/4CF

Attenuation adapter

SCA-1/4EDX1/4-D

Connection cable and single plug

Connection cable, assembled **SCK-400 - xx - xx**

(open cable end)

Cable length (m)

| | |
|------|-----------|
| 2 m | 02 |
| 5 m | 05 |
| 10 m | 10 |

Connector

| | |
|----------------------------|-----------|
| M12 cable jack; straight | 45 |
| M12 cable jack; 90° angled | 55 |

Single connector

M12 cable jack; straight

SCK-145

M12 cable jack; 90° angled

SCK-155

SCTSDI Modular Temperature Switch

Device features

Display

- Large displays for temperature
- 2-color switching status display
- Reversal of viewing direction by 180°
- Bevelled for better readability
- Units in °C and °F

Easy to use

- 3 tactile buttons
- VDMA-Menu navigation

Outputsignal

- IO-Link interface
- Stable metallic M12x1 thread
- Pin assignment according to VDMA
- With 2 switching outputs and switchable current output between 0..20 and 4..20mA

Housing

- Metallic housing
- High quality surface
- 240° rotatable
- IP67 protection

Measuring element

- M12x1 - 5Pin Connector
- Designed for an external PT1000 input Signal (temperature probe sold separately)
- Measuring range between -50°C and 150°C

Temperature probe

- Installation-space independent: The existing sensor probe can be connected via cable, regardless of location
- Direct connection via M12x1 connector is possible
- Separately available sensor probe: see SCT03



SCTSDI Modular Temperature Switch

Technical data

| Ordercode temperature switch | SCTSDI-150-1T-05 |
|---------------------------------------|------------------|
| Measuring range temperature | -50... 150 |
| Lowest Reset point RSP | -50 |
| Highest Switching Point SP | 150 |
| Display resolution | 0,1 |
| Min. adjustable difference SP and rSP | 1 |

All units in bar

| Process connection | |
|--------------------|----------------|
| Process connection | M12x1 internal |
| Input signal | PT1000 |

| Response speed | |
|------------------|-------|
| Switching output | ≤3 ms |
| Analogue output | ≤3 ms |
| Sample rate | ≤3 ms |

| Output variables | |
|------------------|---------------------------------|
| Strom | 0..20mA or 4..20mA (switchable) |

| Switching point | |
|-------------------------|---|
| Switching current | max. 200 mA |
| Short circuit current | 400mA (short term), short circuit proof |
| Switching voltage | Supply voltage - 0,5 VDC |
| Execution | PNP/ NPN (programmable) |
| Max switching frequency | 250 Hz |

| Accuracy (temperature) | |
|------------------------|--------------------|
| @ 25°C | ±0,35% FS ±1 Digit |
| @ -20..+150°C | ±1,5% FS ±1 Digit |

| Electrical connection | |
|-----------------------------|--------------|
| Supply voltage V_{+} | 18...30 VDC |
| Connector | M12x1; 5pin |
| Short circuit protection | Yes |
| Reverse polarity protection | Yes |
| Overload protection | Yes |
| Overvoltage | 50 V |
| Current consumption | <40 mA @24V |
| Inrush current | <100 mA @24V |

| IO-Link | |
|-----------------------|---|
| Profile | Smart Sensor Profile 2nd Edition V1.1.2 |
| Prozess Zykluszeit | 4 ms |
| SIO-Mode | Yes |
| Master port type | A |
| Process data analogue | 2 Byte Process data 1 Byte Scaling factor |
| Process data binary | 1 Byte |
| SDCI Standard | IEC 61131-9 |
| Vendor ID | 271 (dec) / 10f (hex) |
| Device IODD | https://parker.com/ |

SCTSDI Modular Temperature Switch

Technical data

| Housing | | EM-compatibility | |
|---------------------|--|---|------------------------|
| Rotatability | >240° | Immunity to interference | |
| Readability display | Reversal of viewing direction by 180° (programmable) | Emission of interference | EN 55011 |
| Display | 7-Segment-LED (4-digit) | ESD | EN 61000-4-2 |
| | 2-color switching status display (red/yellow) Digit height : 8 mm | high-frequency electromagnetic fields | EN 61000-4-3 |
| Buttons | 3 tactile buttons for up, down, enter | fast transient electrical disturbances | EN 61000-4-4 |
| Material | | Conducted disturbances induced by high-frequency fields | EN 61000-4-6 |
| Housing | Zinc die-cast (bright nickel-plated) | Environmental conditions | |
| Display cover | Polyester Autotex V207 | Ambient temperature | -20...+85 °C |
| Protection class | IP67 | Operating temperature | -20...+85 °C |
| Weight | 300 g | Storage temperature | -40...+85 °C |
| General | | Medium temperature | -20...+85 °C |
| MTTFd | >100 years | Vibration resistance | DIN EN 60068-2-6, 20 g |
| RoHS-Conformity | 2011/65/EU, 2024/232 | Shock resistance | DIN EN 60068-2-27, 50g |

| Compatible temperature probe | SCT03-007-Tx-07 |
|------------------------------|----------------------------------|
| PT1000 | Class A |
| Accuracy | $\pm(0,15K+0,002 \times t)^{*1}$ |

*1 t = measured temperature in °C (DIN EN 60751)

More details: See chapter SCT03 - Catalogue 4083

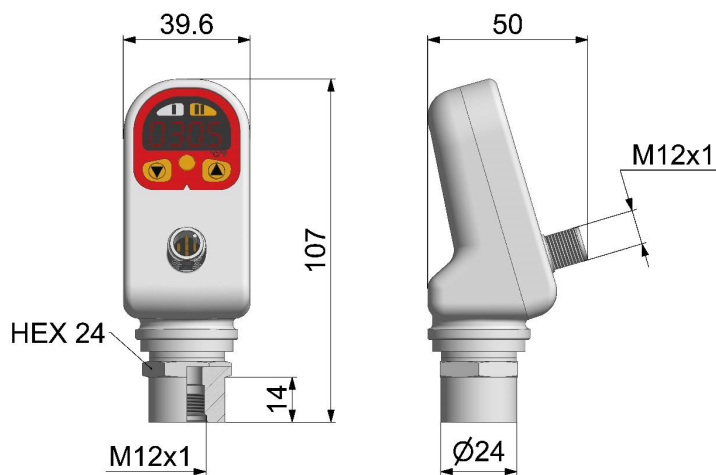

| PIN | Assignment SCTSDI-150-1T-05 (Plug on Top) |
|-----|---|
| 1 | V+ |
| 2 | S2 out |
| 3 | 0 V/GND |
| 4 | S1 out / IO-Link |
| 5 | Analogue out |

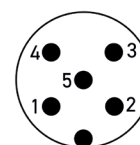

| PIN | Assignment SCTSDI-150-1T-05 (PT1000 socket below) |
|-----|---|
| 1 | PT1000 |
| 2 | - |
| 3 | PT1000 |
| 4 | - |
| 5 | - |

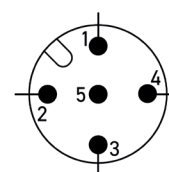

SCTSDI Modular Temperature Switch

Order code

SCTSDI Digital temperature switch

2 switching points; no analogue output **SCTSDI-150-1T-05**

M12x1 connector; 5-Pin

Accessory

Securing clamp

Reducing adapter M22x1,5

Reducing adapter G1/2 BSPP

Attenuation adapter

PT1000 temperature probe

SCSD-S24

RI22X1.5EDX1/4CF

SCA-1/4-ED-1/2-ED

SCA-1/4EDX1/4-D

SCT03 (see chapter SCT03 - catalogue 4083)

Connection cable and single plug

Connection cable, assembled

SCK-400-xx-xx

(open cable end)

Cable length (m)

2 m

5 m

10 m

02

05

10

Connector

M12 cable jack; straight

M12 cable jack; 90° angled

45

55

Single connector

M12 cable jack; straight

M12 cable jack; 90° angled

Adapter connector M12x1

SCK-145

SCK-155

SCK-401-4M

SCTSDI Modular Temperature Switch

Functional description



SCK-401-4M
(Adapter connector)



SCK-400-xx-xx
(Connection cable)

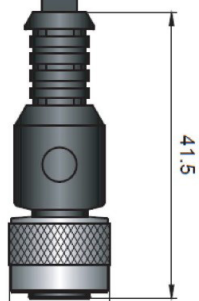

PT1000 from customer application

SCT03 (see chapter SCT03
catalogue 4083)

SCLSDI Level Switch

Device features

Display

- Large Display for level
- 2-color switching status display
- Reversal of viewing direction by 180°
- Beveled for better readability
- Units in mm, cm, m, inch und %

Easy to use

- 3 tactile buttons
- VDMA-Menu navigation

Outputsignal

- IO-Link interface
- Stable metallic M12x1 thread
- Pin assignment according to VDMA
- Can be selected between switching output, current output and voltage output

Housing

- Metallic housing
- High quality surface
- 240° rotatable
- IP67 protection

Installation

- G3/4" external thread
- Stainless Steel 1.4404
- One coupling hole

Float element

- Proven measuring system
- High float dynamics
- Small design
- Universal usage

Measuring element

- Measuring range up to 1000mm
- High Pressure rating up to 5bar
- High accuracy up to 0,5% FS
- Long-term stable measuring cell

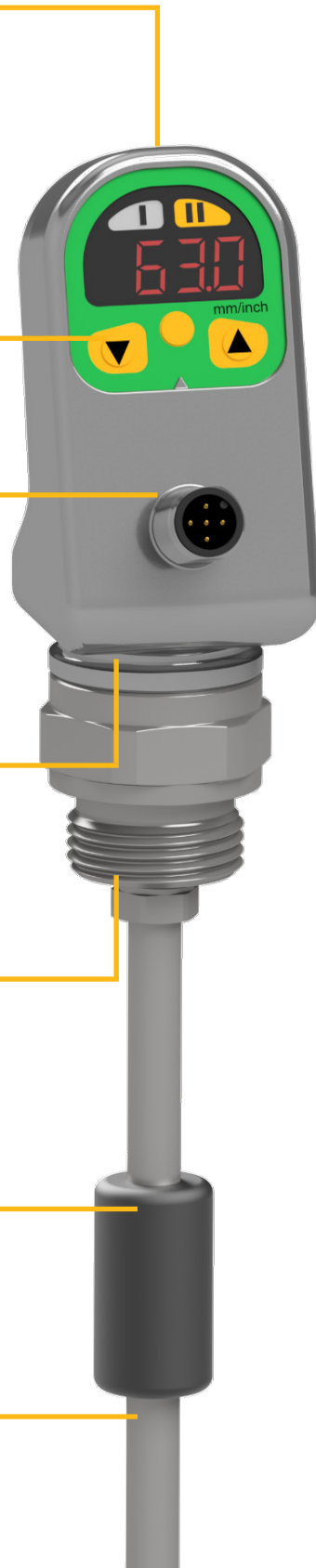

SCLSDI Level Switch

Technical data

| SCLSDI- | 250 | 370 | 520 | 800 | 1000 |
|-------------------------------|----------|----------|----------|----------|----------|
| Measuring range | 30...215 | 30...335 | 30...485 | 20...750 | 20...950 |
| Lowest reset point RSP | 30 | 30 | 30 | 20 | 20 |
| Highest switching point SP | 215 | 335 | 485 | 750 | 950 |
| Display resolution | 5 | 5 | 5 | 10 | 10 |
| Display resolution SP and rSP | 5 | 5 | 5 | 10 | 10 |

All units in mm

Process connection

| | |
|--------------------|--------------------|
| Process connection | G3/4 BSPP external |
| Tightening torque | 165 Nm |

Parts in contact with media

| | |
|-----------------|-------------------------|
| External thread | Stainless Steel: 1.4404 |
| | Sealing: ED NBR SH70 |
| Sliding tube | Stainless steel 1.4301 |
| Float element | NPR |
| Circlip | Bronze |

Output variables

| | |
|---------------|-----------------------------------|
| Current input | 0..20mA or 4..20mA (programmable) |
| Voltage input | 0..10V |

Switching point

| | |
|-------------------------|---|
| Switching current | max. 200 mA |
| Short circuit current | 400mA (short term), short circuit proof |
| Switching voltage | Supply voltage - 0,5 VDC |
| Execution | PNP/ NPN (programmable) |
| Max switching frequency | 250 Hz |

Accuracy (level)

| | |
|-------------|-------------------|
| @ 25°C | ±0,5% FS ±1 Digit |
| @ -20..+85C | ±1,5% FS ±1 Digit |

Electrical connection

| | |
|-----------------------------|---------------------------|
| Supply voltage V_{+} | 18...30 VDC |
| Connector | M12x1; 4pol / M12x1; 5pol |
| Short circuit protection | Yes |
| Reverse polarity protection | Yes |
| Overload protection | Yes |
| Overvoltage | 50 V |
| Current consumption | <40 mA @24V |
| Inrush current | <100 mA @24V |

IO-Link

| | |
|-----------------------|---|
| Profile: | Smart Sensor Profile 2nd Edition V1.1.2 |
| Process Cyklustime | 4 ms |
| SIO-Mode | Yes |
| Master port type | A |
| Process data analogue | 2 Byte Process data |
| | 1 Byte Scaling factor |
| Process data binary | 1 Byte |
| SDCI Standard | IEC 61131-9 |
| Vendor ID | 271 (dec) / 10f (hex) |
| Device IODD | https://parker.com/ |

Response speed

| | |
|------------------|-------|
| Switching output | ≤3 ms |
| Analogue output | ≤3 ms |
| Sample rate | ≤3 ms |

SCLSDI Level Switch

Technical data

| Housing | | EM compatibility | |
|---------------------|--|---|------------------------|
| Rotatability | >240° | Immunity to interference | |
| Readability display | Reversal of viewing direction by 180° (programmable) | Emission of interference | EN 55011 |
| Display | 7-Segment-LED (4-digit) | ESD | EN 61000-4-2 |
| | 2-color switching status display (red/yellow) Digit height : 8 mm | high-frequency electro-magnetic fields | EN 61000-4-3 |
| Buttons | 3 tactile buttons for up, down, enter | fast transient electrical disturbances | EN 61000-4-4 |
| Material | | Conducted disturbances induced by high-frequency fields | EN 61000-4-6 |
| Housing | Zinc die-cast (bright nickel-plated) | Environmental conditions | |
| Display cover | Polyester Autotex V207 | Ambient temperature | -20...+85 °C |
| Protection class | IP67 | Operating temperature | -20...+85 °C |
| Weight | ~470 g | Storage temperature | -40...+85 °C |
| General | | Medium temperature | -20...+85 °C |
| MTTFd | >100 years | Vibration resistance | DIN EN 60068-2-6, 20 g |
| RoHS-Conformity | 2011/65/EU, 2024/232 | Shock resistance | DIN EN 60068-2-27, 50g |
| Float dimensions | | | |
| M. Range<= 520mm | Ø17,8mm / length = 32mm | | |
| M. Range<= 520mm | Ø21mm/ length = 36mm | | |

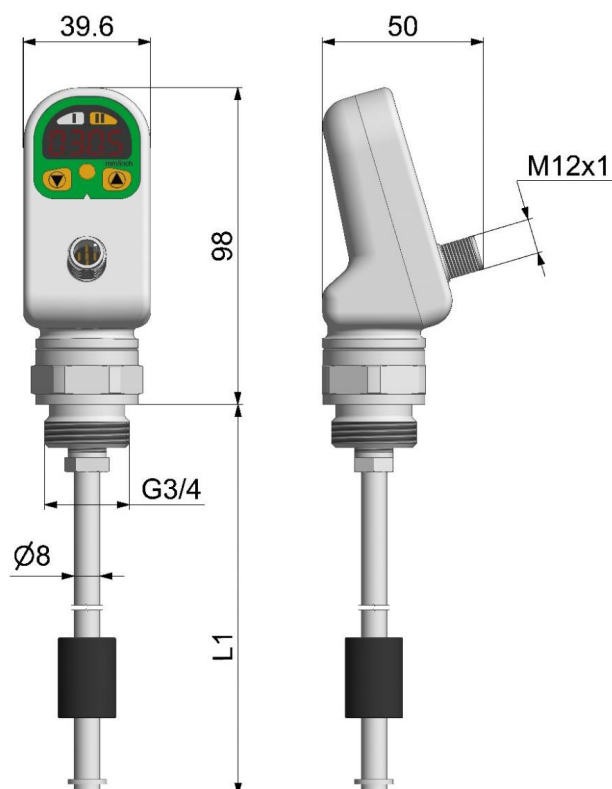

SCLSDI Level Switch

Order code

SCLSDI Digital Level switch

2 switching points; no analogue output SCLSDI-xxx-00-07
M12x1 connector; 4-Pin

1 switching point; with current output SCLSDI-xxx-10-07
M12x1 connector; 4-Pin

2 switching points; with current output or voltage output SCLSDI-xxx-x0-05
M12x1 connector; 5-Pin

Installation length L1

| | |
|---------|------|
| 250 mm | 250 |
| 370 mm | 370 |
| 520 mm | 520 |
| 800 mm | 800 |
| 1000 mm | 1000 |

Analogue output

| | |
|---------------------|---|
| No analogue output | 0 |
| 0..20 mA / 4..20 mA | 1 |
| 0..10 V | 4 |

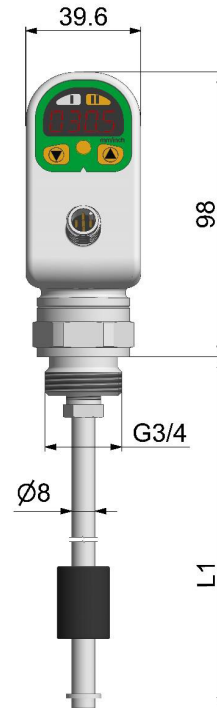

Accessory

| | |
|----------------------------|------------------|
| Securing clamp | SCSD-S24 |
| Reducing adapter M22x1,5 | RI22X1.5EDX1/4CF |
| Reducing adapter G1/2 BSPP | RI1/2EDX1/4CF |
| Attenuation adapter | SCA-1/4EDX1/4-D |

Connection cable and single plug

Connection cable, assembled (open cable end) SCK-400-xx-xx

| | |
|------------------|----|
| Cable length (m) | |
| 2 m | 02 |
| 5 m | 05 |
| 10 m | 10 |

Connecting plug

| | |
|----------------------------|----|
| M12 cable jack; straight | 45 |
| M12 cable jack; 90° angled | 55 |

Single connector

| | |
|----------------------------|---------|
| M12 cable jack; straight | SCK-145 |
| M12 cable jack; 90° angled | SCK-155 |

| PIN | SCxSDI-xxx-x4-x7 |
|-----|------------------|
| 1 | V ₊ |
| 2 | Analogue out |
| 3 | 0 V/GND |
| 4 | S1 out / IO-Link |

| PIN | SCxSDI-xxx-04-x7 |
|-----|------------------|
| 1 | V ₊ |
| 2 | S2 out |
| 3 | 0 V / GND |
| 4 | S1 out / IO-Link |

| PIN | SCxSDI-xxx-x4-x5 |
|-----|------------------|
| 1 | V ₊ |
| 2 | S2 out |
| 3 | 0 V/GND |
| 4 | S1 out / IO-Link |
| 5 | Analogue out |

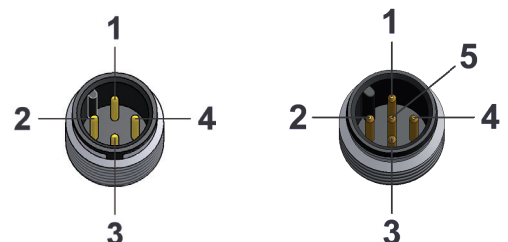

SCLTSDI Level/Temperature Switch

Device features

Display

- Large displays for level and temperature
- 2-color switching status display
- Reversal of viewing direction by 180°
- Bevelled for better readability
- Units:
 - Level = mm, cm, m, inch and %
 - Temp = °C and °F

Easy to use

- 3 tactile buttons
- VDMA-Menu navigation

Outputsignal

- IO-Link interface
- Stable metallic M12x1 thread
- Pin assignment according to VDMA
- Can be selected between switching output, current output and voltage output

Housing

- Metallic housing
- High quality surface
- 240° rotatable
- IP67 protection

Installation

- G3/4" external thread
- Brass: CW724R
- 2 in 1 concept
- One coupling hole

Float element

- Proven measuring system
- High float dynamics
- Small design
- Universal usage

Measuring element

- Measuring range up to 1000mm and 85°C
- Tempsensor element integrated in the rod end
- High Pressure rating up to 5 bar
- High accuracy up to 0,5% FS
- Long-term stable measuring cell

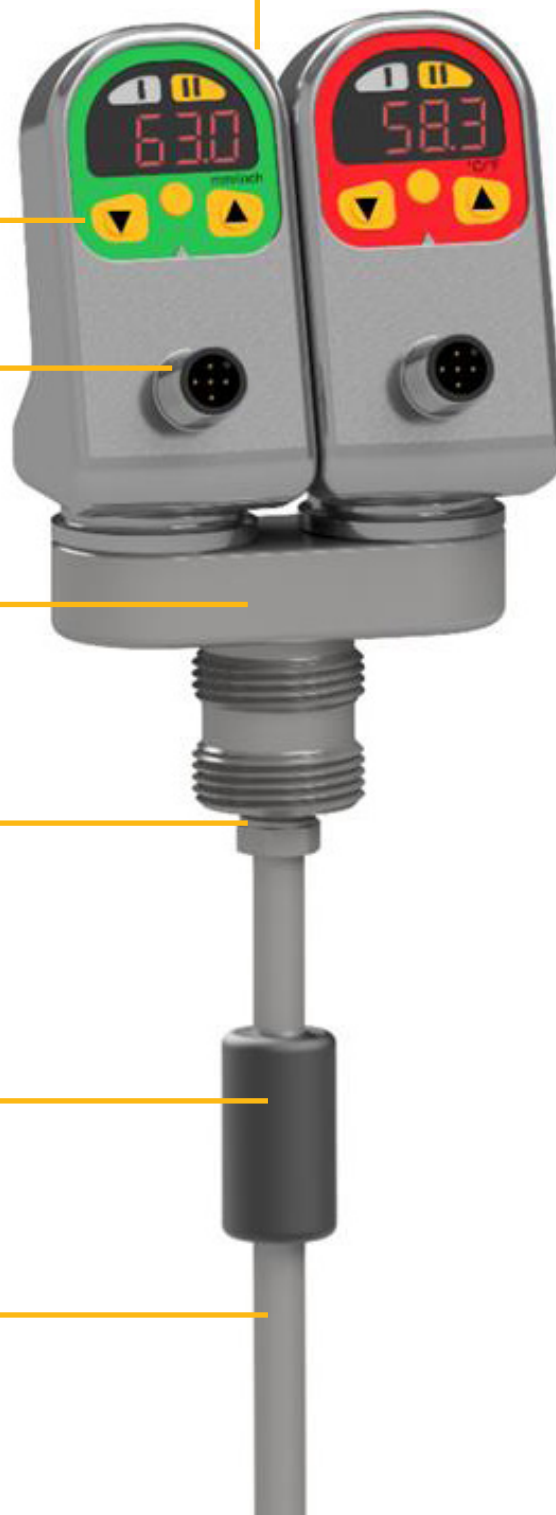

SCLTSDI Level/Temperature Switch

Technical data

| SCLSDI- | 250 | 370 | 520 | 800 | 1000 |
|-------------------------------|---------------|---------------|---------------|---------------|---------------|
| Measuring range | 30...215 | 30...335 | 30...485 | 20...750 | 20...950 |
| Lowest reset point RSP | 30 | 30 | 30 | 20 | 20 |
| Highest switching point SP | 215 | 335 | 485 | 750 | 950 |
| Display resolution | 5 | 5 | 5 | 10 | 10 |
| Display resolution SP und rSP | 5 | 5 | 5 | 10 | 10 |
| Measuring temperature range | -20°C .. 85°C | -20°C .. 85°C | -20°C .. 85°C | -20°C .. 85°C | -20°C .. 85°C |

All units in mm

| Process connection | |
|-----------------------------|--|
| Process connection | G3/4 BSPP external |
| Tightening torque | 105 Nm |
| Parts in contact with media | |
| External thread | Brass: CW724R (CuZn21Si3P) Sealing: ED NBR SH70 |
| Sliding tube | Stainless steel 1.4301 |
| Float element | NBR |
| Circlip | Bronze |

| Output variables | |
|-------------------------|---|
| Current input | 0..20mA or 4..20mA (programmable) |
| Voltage input | 0..10V |
| Switching point | |
| Switching current: | max. 200 mA |
| Short circuit current: | 400mA (short term), short circuit proof |
| Switching voltage: | Supply voltage - 0,5 VDC |
| Execution: | PNP/ NPN (programmable) |
| Max switching frequency | 250 Hz |

| Accuracy (level) | |
|------------------------|--------------------|
| @ 25°C | ±0,50% FS ±1 Digit |
| @ -20...+85C | ±1,5% FS ±1 Digit |
| Accuracy (temperature) | |
| @ 25°C | ±0,35% FS ±1 Digit |
| @ -20...+85C | ±1,5% FS ±1 Digit |

| Electrical connection | |
|-----------------------------|---------------------------|
| Supply voltage V_{+} | 18...30 VDC |
| Connector | M12x1; 4pol / M12x1; 5pol |
| Short circuit protection | Yes |
| Reverse polarity protection | Yes |
| Overload protection | Yes |
| Overvoltage | 50 V |
| Current consumption | <40 mA @24V |
| Inrush current | <100 mA @24V |

| IO-Link | |
|-----------------------|---|
| Profile: | Smart Sensor Profile 2nd Edition V1.1.2 |
| Process Cyklustime | 4 ms |
| SIO-Mode | Yes |
| Master port type | A |
| Process data analogue | 2 Byte Process data 1 Byte Scaling factor |
| Process data binary | 1 Byte |
| SDCI Standard | IEC 61131-9 |
| Vendor ID | 271 (dec) / 10f (hex) |
| Device IODD | https://parker.com/ |

| Response speed | |
|------------------|-------|
| Switching output | ≤3 ms |
| Analogue output | ≤3 ms |
| Sample rate | ≤3 ms |

SCLTSDI Level/Temperature Switch

Technical data

| Housing | |
|---------------------|--|
| Rotatability | >240° |
| Readability display | Reversal of viewing direction by 180° (programmable) |
| Display | 7-Segment-LED (4-digit) |
| | 2-color switching status display (red/yellow) Digit height : 8 mm |
| Buttons | 3 tactile buttons for up, down, enter |
| Material | |
| Housing | Zinc die-cast (bright nickel-plated) |
| Display cover | Polyester Autotex V207 |
| Protection class | IP67 |
| Weight | ~860 g |
| General | |
| MTTFd | >100 years |
| RoHS-Conformity | 2011/65/EU, 2024/232 |
| Float dimensions | |
| M. Range<= 520mm | Ø17,8mm / length = 32mm |
| M. Range<= 520mm | Ø21mm/ length = 36mm |

| EM compatibility | |
|---|------------------------|
| Immunity to interference | |
| Emission of interference | EN 55011 |
| ESD | EN 61000-4-2 |
| high-frequency electromagnetic fields | EN 61000-4-3 |
| fast transient electrical disturbances | EN 61000-4-4 |
| Conducted disturbances induced by high-frequency fields | EN 61000-4-6 |
| Environmental conditions | |
| Ambient temperature | -20...+85 °C |
| Operating temperature | -20...+85 °C |
| Storage temperature | -40...+85 °C |
| Medium temperature | -20...+85 °C |
| Vibration resistance | DIN EN 60068-2-6, 20 g |
| Shock resistance | DIN EN 60068-2-27, 50g |

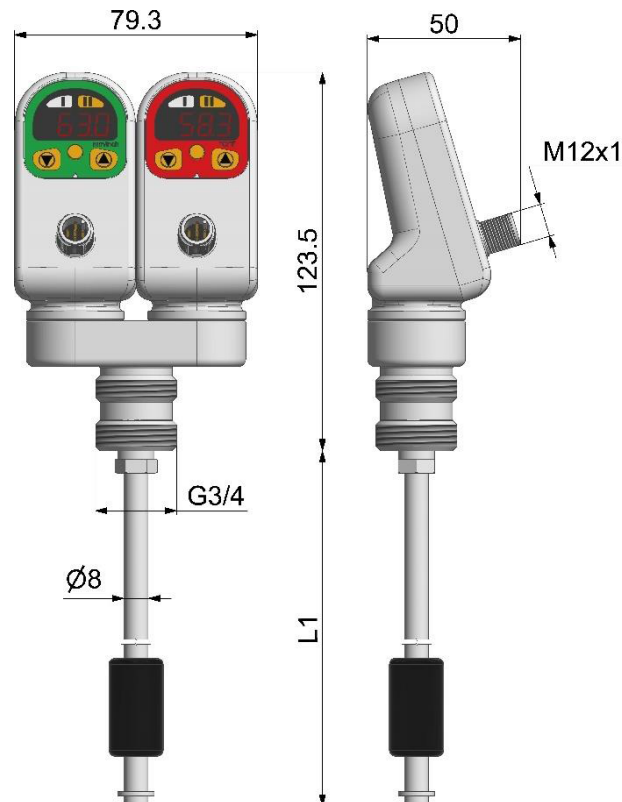

SCLTSDI Level/Temperature Switch

Order code

SCLTSDI Digital Level/Temp switch

2 switching points; no analogue output SCLTSDI-xxx-00-07
M12x1 connector; 4-Pin

1 switching point; with current output SCLTSDI-xxx-10-07
M12x1 connector; 4-Pin

2 switching points; with current output or voltage output SCLTSDI-xxx-x0-05
M12x1 connector; 5-Pin

Installation length L1 mm

| | |
|---------|------|
| 250 mm | 250 |
| 370 mm | 370 |
| 520 mm | 520 |
| 800 mm | 800 |
| 1000 mm | 1000 |

Analogue output

| | |
|---------------------|---|
| No analogue output | 0 |
| 0..20 mA / 4..20 mA | 1 |
| 0..10 V | 4 |

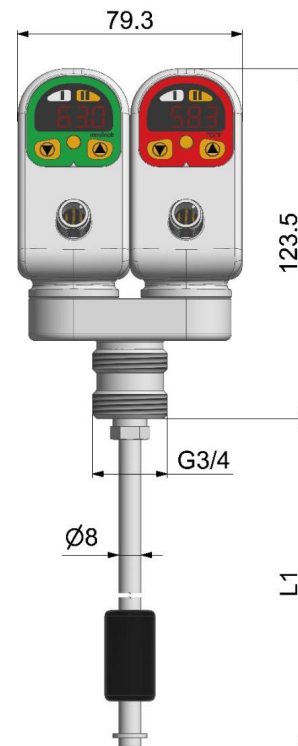

Accessory

Securing clamp
Reducing adapter M22x1,5
Reducing adapter G1/2 BSPP
Attenuation adapter

SCSD-S24
RI22X1.5EDX1/4CF
RI1/2EDX1/4CF
SCA-1/4EDX1/4-D

Connection cable and single plug

Connection cable, assembled

(open cable end)

SCK-400-xx-xx

Cable length (m)

| | |
|------|----|
| 2 m | 02 |
| 5 m | 05 |
| 10 m | 10 |

Connector

| | |
|----------------------------|----|
| M12 cable jack; straight | 45 |
| M12 cable jack; 90° angled | 55 |

Single connector

M12 cable jack; straight **SCK-145**
M12 cable jack; 90° angled **SCK-155**

| PIN | SCxSDI-xxx-x4-x7 |
|-----|------------------|
| 1 | V ₊ |
| 2 | Analogue out |
| 3 | 0 V/GND |
| 4 | S1 out / IO-Link |

| PIN | SCxSDI-xxx-04-x7 |
|-----|------------------|
| 1 | V ₊ |
| 2 | S2 out |
| 3 | 0 V/GND |
| 4 | S1 out / IO-Link |

| PIN | SCxSDI-xxx-x4-x5 |
|-----|------------------|
| 1 | V ₊ |
| 2 | S2 out |
| 3 | 0 V/GND |
| 4 | S1 out / IO-Link |
| 5 | Analogue out |

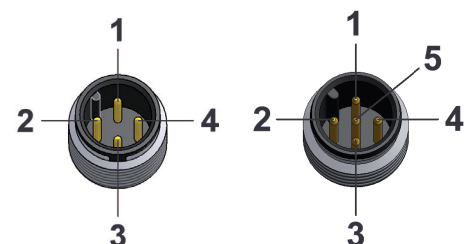

SCK cable

Device features

- One cable for all
- Compact size
- Interference-free
- Compatible to:
 - Sensors
 - Controllers
- M12 plug
- DIN EN 175301 (Device plug)
- Available in a variety of lengths



The **SensoControl®** cable was designed for use with the industrial sensors and switches.

Thus the M12 cable and M12 plug are

- Compact
- Shielded
- Five-pole

5-pole version

The 5-pole cable is suitable for both 4-pole and 5-pole connections. The sensor variants with a 4-pole connector are fully compatible with the 5-pole cable.

So despite different pin counts on the pressures switch (Controller Family SCxSD and SCOTC) and sensors, it is always possible to use just one cable version (5-pole) regardless of the plug version.

The SCK-400-xxx-x5 cables fit to all components in this catalogue using M12 connectors.

Shielding

Shielding protects against interference and ensures improved operational safety.

- Higher EMC protection

Pin assignment

SCK-400-xx-x5

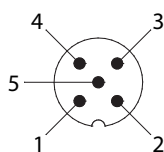

| PIN | | | |
|-----|----|-------|---------|
| 1 | bn | brown | braun |
| 2 | wh | white | weiß |
| 3 | bu | blue | blau |
| 4 | bk | black | schwarz |
| 5 | gy | grey | grau |

SCK-400-xx-56



| PIN | | | |
|-----|----|--------|-------|
| 1 | ye | yellow | gelb |
| 2 | gn | green | grün |
| 3 | bn | brown | braun |
| | | | |

SCK cable

Connection cable

SCK-400-xx-45

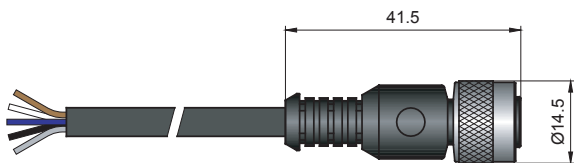

SCK-400-xx-55

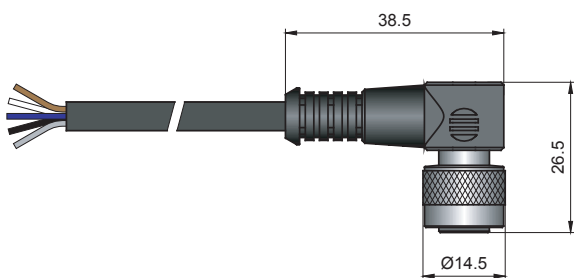

SCK-400-xx-56

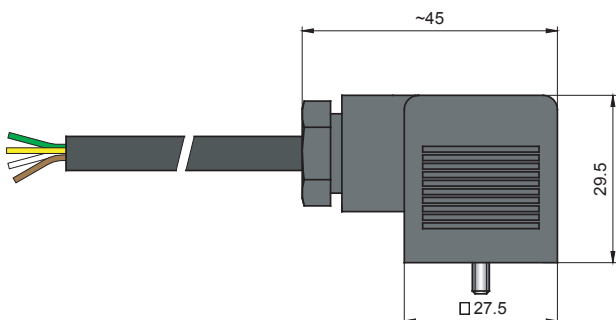

Single connector

SCK-006 (Device plug)

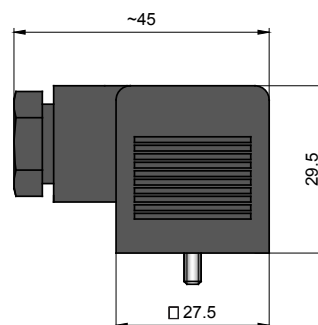

Single connector

SCK-145

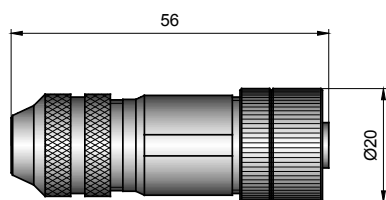

SCK-155

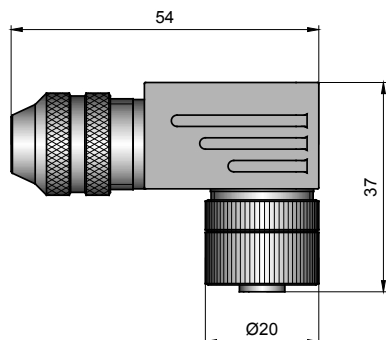

Connection cable and single plug

Connection cable, assembled

(open cable end)

Cable length (m)

| | |
|------|----|
| 2 m | 02 |
| 5 m | 05 |
| 10 m | 10 |

Connecting plug

| | |
|---|----|
| M12 cable jack; straight | 45 |
| M12 cable jack; 90° angled | 55 |
| Cable socket DIN EN 175301-803 Form A (old DIN 43650) | 56 |

Single connector

| | |
|---|---------|
| M12 cable jack; straight | SCK-145 |
| M12 cable jack; 90° angled | SCK-155 |
| Cable socket DIN EN 175301-803 Form A (old DIN 43650) | SCK-006 |

SCA adapter

SCA-1/4 reduction adapter

The SCA-1/4 provides compatibility for earlier sensor versions with the hydraulic connection M22x1.5 or G1/2 BSPP.

- When replacing earlier versions

This allows facilities to be updated without major planning overhead.

SCA-1/4-M22x1.5-ED
SCA-1/4-ED-1/2-ED

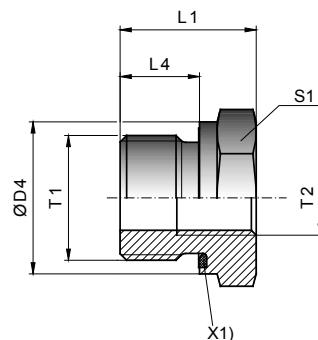

X1) EOLASTIC-seal

| | T1 | T2 | ØD4 | L1 | L4 | S1 | Weight (g/1 St) | PN (bar) ¹⁾ | DF ** |
|---------------------------|-----------|-----------|-----|----|----|----|-----------------|------------------------|-------|
| SCA-1/4-M22x1.5-ED | M22x1.5 | G1/4 BSPP | 27 | 24 | 14 | 27 | 56 | 400 | 4 |
| SCA-1/4ED1/2-ED | G1/2 BSPP | G1/4 BSPP | 27 | 24 | 14 | 27 | 56 | 400 | 4 |

SCA-1/4 attenuation adapter

System-related pressure spikes are reduced with the SCA-1/4-EDX-1/4-D.

- Attenuation for pressure peaks

The G1/2 BSPP version ensures compatibility for earlier sensor versions to the G1/2 BSPP hydraulic connection.

- When replacing earlier versions

SCA-1/4-EDX-1/4-D

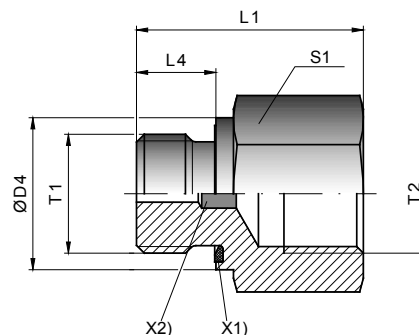

X1) EOLASTIC-seal

| | T1 | T2 | ØD4 | L1 | L4 | S1 | Weight (g/1 St) | PN (bar) ¹⁾ | DF ** |
|------------------------|------------|-----------|-----|----|----|----|-----------------|------------------------|-------|
| SCA-1/4EDX1/4-D | G1/4A BSPP | G1/4 BSPP | 19 | 34 | 12 | 22 | 61 | 630 | 3.5 |

SCA adapter

SCPSD flange adapter SCAF-1/4-40 for mechanical pressure switch

When replacing existing mechanical pressures switches SCAF-1/4-40 with 40x40mm flange connections

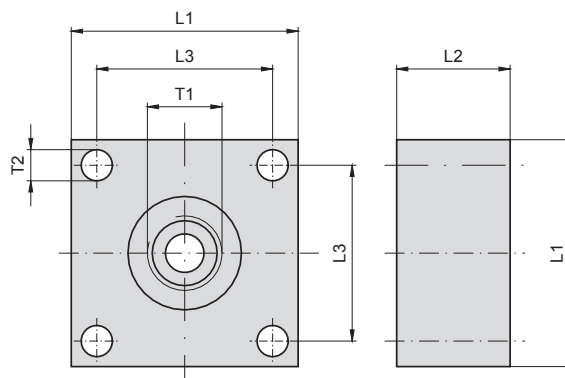

SCAF-1/4-40
for mechanical pressure switch

SCAF-1/4-40

| T1 | T2 | L1 | L2 | L3 | Weight (g/1 St) | PN (bar) ¹⁾ Alu | DF ** |
|-----------|-----|----|----|----|-----------------|----------------------------|-------|
| G1/4 BSPP | 5.5 | 40 | 20 | 31 | 15 | 400 | 4 |

SCLSD/SCLTSD flange adapter SCAF-3/4-90 6-hole connection DIN 24557, part 2

For LevelController and LevelTemp Controller (SCLSD and SCLTSD), a compatibility to the tank connections 6-hole DIN 24557, part 2, is ensured.

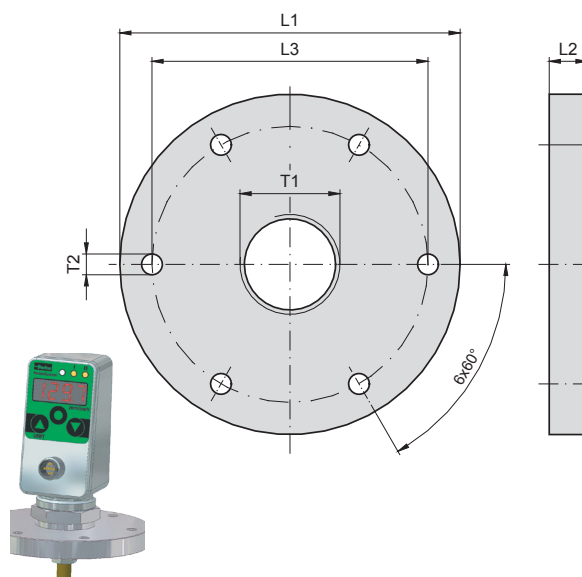

SCAF-3/4-90
6-hole connection DIN 24557, part 2

SCAF-3/4-90

| T1 | T2 | L1 | L2 | L3 | Weight (g/1 St) | Material |
|-----------|-----|----|----|----|-----------------|-----------------|
| G3/4 BSPP | 5.5 | 90 | 10 | 73 | 520 | Stainless steel |

** DF = Design Factor (safety factor)

Installation and safety instructions

 The CE mark indicates a high-quality device that complies with the European directive 89/336/EWG and EMVG.

We confirm that these products comply with the following standards:

EMC

- Electromagnetic emission: EN 61000-6-3
- Electromagnetic immunity: EN 61000-6-2

Important

- Electromagnetic disturbances can affect the desired signal.
- Apply all general EMC strategies when planning facilities and machines.
- We recommend using shielded cables (SCK-400-xx-x5) in order to achieve better EMC immunity.
- Make sure you route analogue and data cables so that there is a sufficient gap between them.
- An effective earthing strategy will help you to avoid measuring errors.

Always connect metal housings with the reference ground. The PE protective earth should have a low-ohm connection. According to VDE 0701, the PE resistance must be measured.

Power feed voltage



Each sensor series specifies the recommended feed voltage to be used when operating the standard sensor. We recommend using a low-noise, high-quality, constant voltage source. Certain specifications (such as sensitivity and thermal sensitivity shift) may change when other power feeds are used. Each sensor is trimmed to its peak performance. The sensor's performance may change when other power feed types are used. Make sure you comply with the polarity and earthing regulations.

Improperly connected feed wires can damage sensors and amplifiers!

If one pole of the sensor feed is automatically earthed via the sensor's processing system, then you should avoid an additional earth on the sensor signal wire. This would cause the sensor to short circuit and damage the sensor.

Do not apply feed-in voltage to the output wires. This will permanently damage the sensors!



The sensor will be damaged if the data sheet specifications and maximum recommended feed voltage levels are exceeded!

Compatibility with media (substances)

SensoControl® products which come into contact with the substance are not produced in an oil-free or fat-free environment.

Therefore these products are **not** suitable for use in applications which use explosive mixtures of oil and gas (e.g. oxygen or compression). This could lead to a danger of explosion!

Danger of explosion!

Only use substances which are compatible with the components that come into contact with the substance. (Refer to the data sheets)

Please consult with the plant manufacturer or the manufacturer of the substance if you have any questions. (Refer to catalogue 4100 chapter C).

Pressure range selection

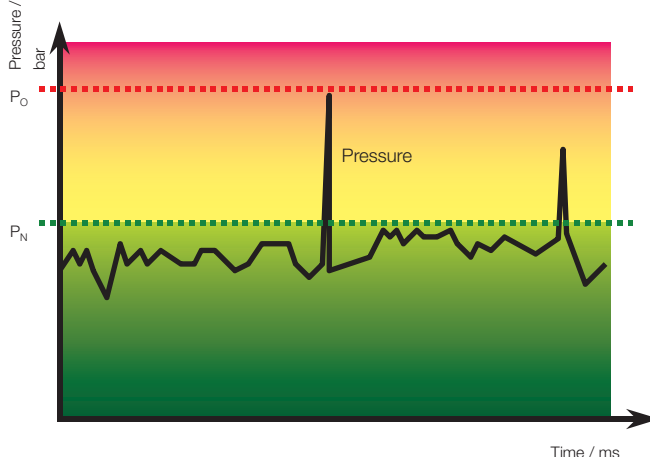

When selecting pressure components, ensure that the overload pressure P_{max} will not be exceeded.

It is possible that the pressure cell can be deformed when the overload pressure P_{max} is exceeded (depending on the duration, frequency and level of the pressure spike).

Note: The "diesel effect" caused by entrapped air can result in pressure spikes that far exceed the maximum pressure.

The nominal pressure P_N of the pressure component (sensor/switch) should be higher than the nominal pressure of the system to be measured.

Appendix

Temperature conversion table

Celsius to Fahrenheit

| °C | °F |
|-----|-----|
| 150 | 302 |
| 145 | 293 |
| 140 | 284 |
| 135 | 275 |
| 130 | 266 |
| 125 | 257 |
| 120 | 248 |
| 115 | 239 |
| 110 | 230 |
| 105 | 221 |
| 100 | 212 |
| 95 | 203 |
| 90 | 194 |
| 85 | 185 |
| 80 | 176 |
| 75 | 167 |
| 70 | 158 |
| 65 | 149 |
| 60 | 140 |
| 55 | 131 |
| 50 | 122 |
| 45 | 113 |
| 40 | 104 |
| 35 | 95 |
| 30 | 86 |
| 25 | 77 |
| 20 | 68 |
| 15 | 59 |
| 10 | 50 |
| 5 | 41 |
| 0 | 32 |
| -5 | 23 |
| -10 | 14 |
| -15 | 5 |
| -20 | -4 |
| -25 | -13 |
| -30 | -22 |
| -35 | -31 |
| -40 | -40 |
| -45 | -49 |
| -50 | -58 |

Fahrenheit to celsius

| °F | °C |
|-----|-----|
| 340 | 171 |
| 330 | 166 |
| 320 | 160 |
| 310 | 154 |
| 300 | 149 |
| 290 | 143 |
| 280 | 138 |
| 270 | 132 |
| 260 | 127 |
| 250 | 121 |
| 240 | 116 |
| 230 | 110 |
| 220 | 104 |
| 210 | 99 |
| 200 | 93 |
| 190 | 88 |
| 180 | 82 |
| 170 | 77 |
| 160 | 71 |
| 150 | 66 |
| 140 | 60 |
| 130 | 54 |
| 120 | 49 |
| 110 | 43 |
| 100 | 38 |
| 90 | 32 |
| 80 | 27 |
| 70 | 21 |
| 60 | 16 |
| 50 | 10 |
| 40 | 4 |
| 30 | -1 |
| 20 | -7 |
| 10 | -12 |
| 0 | -18 |
| -10 | -23 |
| -20 | -29 |
| -30 | -34 |
| -40 | -40 |
| -50 | -46 |
| -60 | -51 |

Pressure conversion table

bar to psi

| bar | psi |
|------|-------|
| 1000 | 14505 |
| 800 | 11604 |
| 600 | 8703 |
| 500 | 7253 |
| 400 | 5802 |
| 250 | 3626 |
| 160 | 2321 |
| 100 | 1451 |
| 60 | 870 |
| 40 | 580 |
| 35 | 508 |
| 25 | 363 |
| 16 | 232 |
| 10 | 145 |
| 6 | 87 |
| 4 | 58 |
| 2.5 | 36 |
| 1.6 | 23 |
| 1 | 15 |

psi to bar

| psi | bar |
|-------|------|
| 10000 | 689 |
| 9000 | 620 |
| 7000 | 483 |
| 6000 | 414 |
| 4000 | 276 |
| 3000 | 207 |
| 2500 | 172 |
| 1000 | 69 |
| 900 | 62 |
| 600 | 41 |
| 500 | 34 |
| 400 | 28 |
| 250 | 17 |
| 150 | 10.3 |
| 100 | 6.9 |
| 90 | 6.2 |
| 60 | 4.1 |
| 40 | 2.8 |
| 25 | 1.7 |
| 10 | 0.7 |

Examples

Temperature conversion

Initial value: 100

°C in °F: 212 °F

°F in °C: 37.78 °C

Pressure conversion

Initial value: 35

bar in psi: 507.675 psi

psi in bar: 2.41296 bar

Appendix

Index

| | | | |
|--------------------|-------|----------------|-------|
| SC-910 | 49 | SCTSDi | 66-69 |
| SC-911 | 49 | SCTSDi modular | 70-74 |
| SC-912 | 49 | SCQ-150-10-07 | 46-49 |
| SCA-1/4EDX1/2-ED | 85 | SCSD-PRG-KIT | 86 |
| SCA-1/4EDX1/4-D | 85 | SCT03 | 39-43 |
| SCA-1/4-M22x1.5-ED | 85 | SCVF-... | 54-59 |
| SCAF-1/4-40 | 86 | | |
| SCAF-3/4-90 | 86 | | |
| SCAQ-150 | 49 | | |
| SCAQ-GI-R1/2 | 49 | | |
| SCFT-... | 50-53 | | |
| SCK-006 | 84 | | |
| SCK-145 | 84 | | |
| SCK-155 | 84 | | |
| SCK-400-... | 84 | | |
| SCLSD-... | 75-78 | | |
| SCLTSD-... | 79-82 | | |
| SCP03-... | 10-13 | | |
| SCP04-... | 15-19 | | |
| SCP08 | 20-21 | | |
| SCP09 | 22-26 | | |
| SCP10 | 27-31 | | |
| SCP11 | 32-35 | | |
| SCPSD-... | 62-75 | | |
| SCPSi | 36-38 | | |

Old and new references

| Old order number | New order number | Old order number | New order number |
|------------------|------------------|------------------|--------------------------------------|
| SCK-007 | SCK-145 | SCP-xxx-x4-0x-MO | SCP03-xxx-x4-0x |
| SCK-045 | SCK-145 | SCP-xxx-x4-0x | SCP03-xxx-x4-0x |
| SCK-047 | SCK-145 | SCP-xxx-10-06 | SCP03-xxx-14-06 + SCA-1/4-M22x1.5-ED |
| SCK-055 | SCK-155 | SCP-xxx-10-07 | SCP03-xxx-14-07 + SCA-1/4-M22x1.5-ED |
| SCK-057 | SCK-155 | SCP-xxx-12-06 | SCP03-xxx-14-06 + SCA-1/4-ED-1/2-ED |
| SCK-147 | SCK-145 | SCP-xxx-12-07 | SCP03-xxx-14-07 + SCA-1/4-ED-1/2-ED |
| SCK-157 | SCK-155 | SCP-xxx-20-06 | SCP03-xxx-24-06 + SCA-1/4-M22x1.5-ED |
| SCK-200-xxx-45 | SCK-400-xxx-45 | SCP-xxx-20-07 | SCP03-xxx-24-07 + SCA-1/4-M22x1.5-ED |
| SCK-200-xxx-47 | SCK-400-xxx-45 | SCP-xxx-22-06 | SCP03-xxx-24-06 + SCA-1/4-ED-1/2-ED |
| SCK-200-xxx-55 | SCK-400-..55 | SCP-xxx-22-07 | SCP03-xxx-24-07 + SCA-1/4-ED-1/2-ED |
| SCK-200-xxx-56 | SCK400-xxx-56 | SCP-xxx-30-06 | SCP03-xxx-34-06 + SCA-1/4-M22x1.5-ED |
| SCK-200-xxx-57 | SCK-400-..55 | SCP-xxx-30-07 | SCP03-xxx-24-07 + SCA-1/4-M22x1.5-ED |
| SCK-400-xxx-06 | SCK-400-xxx-56 | SCP-xxx-32-06 | SCP03-xxx-34-06 + SCA-1/4-ED-1/2-ED |
| SCK-400-xxx-07 | SCK-400-xxx-45 | SCP-xxx-32-07 | SCP03-xxx-24-07 + SCA-1/4-ED-1/2-ED |
| SCK-400-xxx-47 | SCK-400-xxx-45 | SCP-xxx-40-06 | SCP03-xxx-44-06 + SCA-1/4-M22x1.5-ED |
| SCK-400-xxx-57 | SCK-400-..55 | SCP-xxx-40-07 | SCP03-xxx-44-07 + SCA-1/4-M22x1.5-ED |
| SCPSD-xxx-04-05 | SCPSD-xxx-04-17 | SCP-xxx-42-06 | SCP03-xxx-44-06 + SCA-1/4-ED-1/2-ED |
| SCPSD-xxx-04-06 | SCPSD-xxx-04-16 | SCP-xxx-42-07 | SCP03-xxx-44-07 + SCA-1/4-ED-1/2-ED |
| SCPSD-xxx-04-07 | SCPSD-xxx-04-17 | SCP01 | SCP03 |
| SCPSD-xxx-14-05 | SCPSD-xxx-14-15 | SCP02 | SCP03 |

Please ask about compatible products for non-listed items.

