

HD Series Linear Positioners

Features

- Pre-engineered package
- Performance matched components
- Two performance grades available – standard and industrial
- Protection from environment
- Robust design – exceptional beam strength

The HD Series linear table line is a robust, industrial positioner that is easy to apply, easy to install, and easy to maintain. The robust design begins with a deep channel extruded body and carriage that provide exceptional beam strength and carriage stiffness. The linear bearings and ballscrew are precision components selected for their long life at 100% duty operation. The HD Series also includes IP30 rated belt seals that protect the interior components from debris.



The HD Series is very easy to apply. As part of the configurable part number, users can select options such as screw lead, home and limit sensors, a fail safe brake, and motor orientation. With motors as part of the standard table, system-level performance is provided in the form of graphs to enable quick application without the need for a complex motor sizing exercise.

High Efficiency Ballscrew Drive
is precision ground or precision rolled and offered in 5, 10, 20, and 40 mm leads. Like the linear bearings the screw is self lubricating and is maintenance free for the life of the table.

IP30 Rated Belt Seals
protect the table's internal components from falling debris as well as enhance the overall appearance.

High-Performance Brushless Servo Motor
is performance-matched and included with the table in both in-line and parallel configurations. System level performance data is provided to minimize motor sizing requirements.

Dowel Holes
are provided in the base and carriage for repeatable mounting payloads and the table.

Limit/Home Sensors
Hall effect sensors establish "end of travel" and "home" locations and are easily adjustable over the entire travel length. (not shown)

T-Slot Mounting
is available along the entire body length for convenient attachment of accessories and for flexible toe clamp mounting.

Fail-safe Brake
is available to prevent "back driving" and halt carriage motion in vertical applications during power down. (not shown)

Square Rail Linear Bearing
support the carriage and payload to provide high load capacity with smooth, precise, dependable motion. The bearings are self lubricating and therefore maintenance free over the life of the table.

Deep Channel Extruded Body
Provides significant beam strength, stiffness and is machined to provide exceptional straightness and flatness.



HD Series Life/Load Performance

The following performance information is provided as a supplement to the product specifications pages. The following graphs are used to establish the table life relative to the applied loads. The useful life of a linear table at full catalog specifications is dependent on the forces acting upon it. These forces include both static components resulting from payload weight and dynamic components due to acceleration/deceleration of the load. In multi-axes applications, the primary positioner at the bottom of the stack usually establishes the load limits for the combined axes. When determining life/load, it is critical to include the weight of all positioning elements that contribute to the load supported by the primary axis.

These charts are to be used in conjunction with the corresponding formulas found in the product manuals at www.parker.com/emdusa to establish the life/load for each bearing (4 per table).

Several dimensions, which are specific to each linear positioning table model, and the load geometry are required for these computations. These dimensions are supplied in the catalog information for each positioner. The dimensions are referenced as follows:

- d1 – bearing block center-to-center longitudinal spacing
- d2 – bearing rail center-to-center lateral spacing
- d3 – Rail center-to-carriage mounting surface

Refer to Parker's website www.parkermotion.com for moment loading and other engineering data.

Table Life/Load Compression (Normal) Load

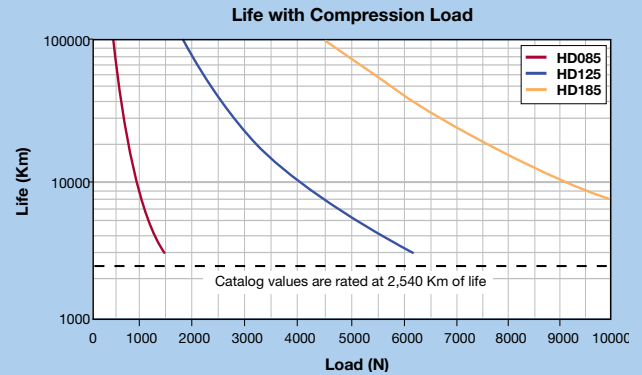

This graph provides evaluation of the support bearing life/load characteristics. The curves show the life/load relationship when the applied load is centered on the carriage, normal (perpendicular) to the carriage mounting surface.

For final evaluation of life vs load, including off center, tension, and side loads, refer to the charts and formulas found at www.parkermotion.com.

	d1	d2	d3
HD085	51	42	53.5
HD125	65	70	57.5
HD185	105	115	42.0

Screw Driven Tables

Bearing Life with Compression or Tension Load

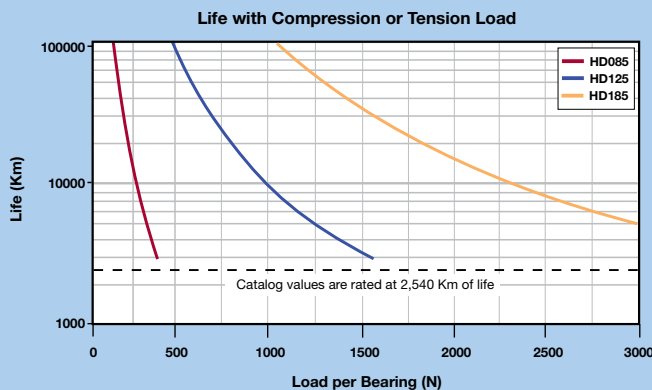

Bearing Life with Side Load

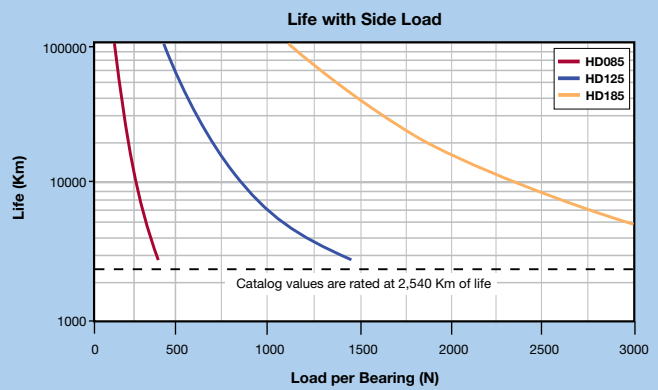

HD085 Series Linear Table
85 mm Wide Profile

Common Characteristics

Performance	Standard	Industrial
Bidirectional Repeatability ⁽¹⁾ – (µm)	±8.0	±50.0
Duty Cycle	100%	100%
Max Acceleration – m/sec ² (in/sec ²)	20 (773)	20 (773)
Rated Normal Load ⁽²⁾ – kgf (lbs)	170 (374)	170 (374)
Rated Axial Loading ⁽³⁾ – kgf (lbs)	90 (198)	90 (198)
Drive Screw Efficiency – %	90	90
Max. Breakaway Torque – Nm (ft-lbs)	0.21 (0.15)	0.21 (0.15)
Running Torque – Nm (ft-lbs)	0.18 (0.13)	0.18 (0.13)
Linear Bearing Coefficient of Friction	0.01	0.01
Carriage Weight – kg (lbs)	0.9 (1.98)	0.9 (1.98)



Travel Dependent Characteristics

Travel	Positional Accuracy ⁽¹⁾ (µm)		Straightness & Flatness Accuracy (µm)		Max. Velocity (mm/sec.) @ Specified Lead			Input Inertia (kg-m ² x 10 ⁻⁵) @ Specified Lead			Total Table Weight (kg)
	Standard	Industrial	Standard	Industrial	5 mm	10 mm	20 mm	5 mm	10 mm	20 mm	
100	25	50	10	20	370	740	1480	1.826	1.925	2.322	3.86
200	25	50	15	30	370	740	1480	2.214	2.313	2.710	4.56
300	30	75	20	40	370	740	1480	2.601	2.701	3.097	5.26
400	35	100	25	50	370	740	1480	2.989	3.088	3.485	5.96
500	40	120	30	60	370	740	1480	3.377	3.476	3.873	6.66
600	45	130	35	70	260	520	1040	3.764	3.864	4.260	7.36
800	55	150	45	90	180	360	720	4.540	4.639	5.036	8.76
1000	65	200	55	110	—	240	480	—	5.414	5.811	10.16
1200	75	250	65	130	—	170	340	—	6.190	6.586	11.56

Motor Characteristics

	M01x M02x SM232AE	M11x M12x SM232AQ	M100 Series* HV232	M100 Parallel* HV232
Max. Voltage	340	340	170	170
Peak Current	8.3	8.3	1.38	2.76
RMS Current	2.0	2.0	1.38	2.76
Resistance	7.50	7.50	3.41	0.85
Inductance	2.90	2.90	12.28	3.07
Recommended Drive	S025	AR-04	E-AC	E-AC

* Series/Parallel denotes wiring of step motor to drive

(1) Accuracy and Repeatability apply to in-line motors only. Contact factory for parallel motor configurations. The accuracy and repeatability shown are for mechanics only and assume no error contribution from the motor. With standard 4000 count encoders an additional error must be added to both the accuracy and repeatability. For 5 mm lead add 1.25 microns, for 10 mm leads add 2.5 microns and for 20 mm leads add 5 microns of error to the accuracy and repeatability value stated above.

(2) Normal load capacities apply to centralized load on the linear bearing to a life of 2540 Km. Refer to life/load charts to determine life of your particular application. Normal load capacity ratings are to be used as a reference of linear bearing load to life rating. This value SHOULD NOT be used as a safe loading value since other application factors (such as mounting) affect the safe load rating.

(3) Axial load capacities assumes an average axial load on a 10 mm lead ball screw and a life of 2540 Km. Refer to life/load charts to determine life of your particular application.



HD085 Thrust versus Velocity

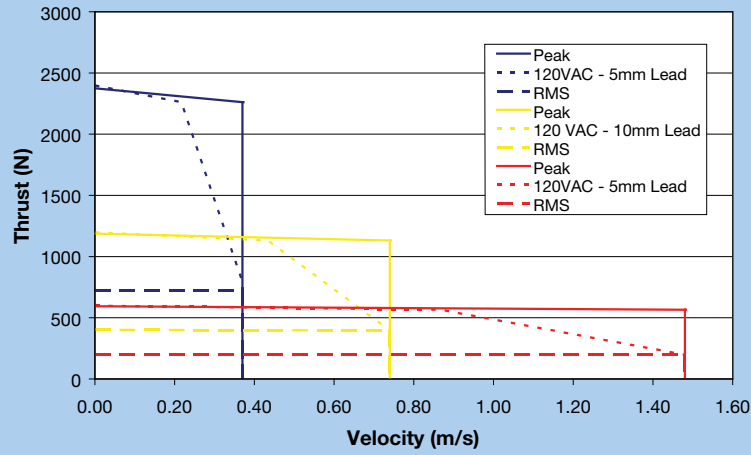

HD085 Inertia Ratios

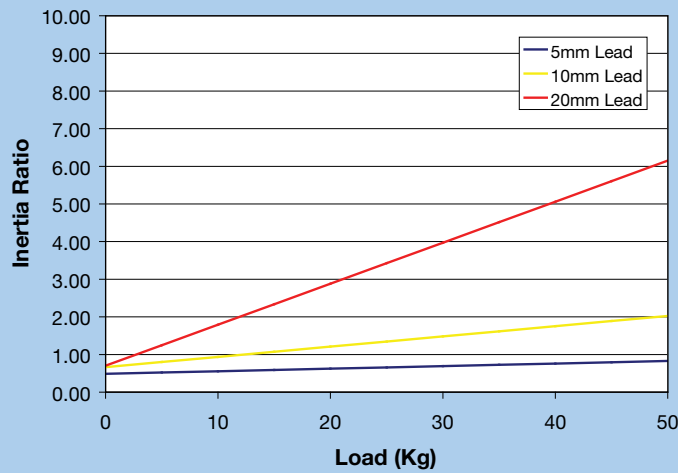

HD085 Acceleration Rates

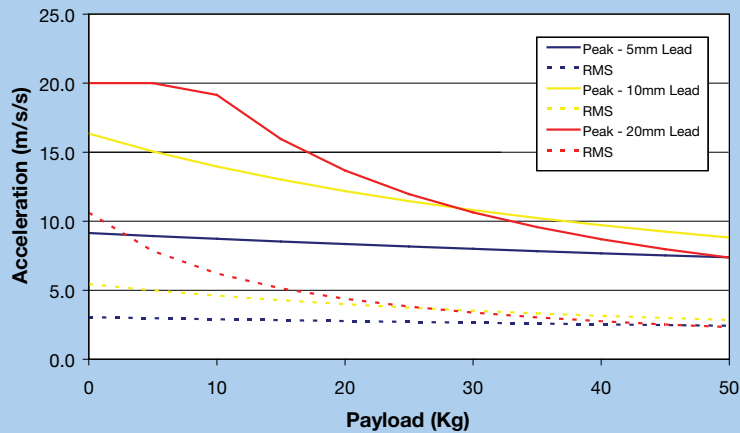

**HD125 Series Linear Table
125 mm Wide Profile**

Common Characteristics

Performance	Standard	Industrial
Bidirectional Repeatability ⁽¹⁾ – (µm)	±8.0	±50.0
Duty Cycle	100%	100%
Max Acceleration – m/sec ² (in/sec ²)	20 (773)	20 (773)
Rated Normal Load ⁽²⁾ – kgf (lbs)	630 (1390)	630 (1390)
Rated Axial Loading ⁽³⁾ – kgf (lbs)	90 (198)	90 (198)
Drive Screw Efficiency – %	90	90
Max. Breakaway Torque – Nm (ft-lbs)		
0 to 1000 mm Travel	0.25 (0.18)	0.25 (0.18)
1200 to 1500 mm Travel	0.35 (0.26)	0.35 (0.26)
Running Torque – Nm (ft-lbs)		
0 to 1000 mm Travel	0.21 (0.15)	0.21 (0.15)
1200 to 1500 mm Travel	0.32 (0.24)	0.32 (0.24)
Linear Bearing Coefficient of Friction	0.01	0.01
Carriage Weight – kg (lbs)	2.2 (4.84)	2.2 (4.84)



Travel Dependent Characteristics

Travel	Positional Accuracy ⁽¹⁾ (µm)		Straightness & Flatness Accuracy (µm)		Max. Velocity (mm/sec.) @ Specified Lead				Input Inertia (kg-m ² x 10 ⁻⁵) @ Specified Lead				Total Table Weight (kg)
	Std	Ind	Std	Ind	5 mm	10 mm	20 mm	40 mm	5 mm	10 mm	20 mm	40 mm	
200	25	50	15	30	370	740	1480	2240	3.061	3.416	4.834	14.386	11.50
300	30	75	20	40	370	740	1480	2240	3.449	3.804	5.222	15.612	12.75
400	35	100	25	50	370	740	1480	2240	3.837	4.191	5.610	16.837	14.00
500	40	120	30	60	315	630	1260	2240	4.224	4.579	5.997	18.062	15.25
600	45	130	35	70	240	480	960	1920	4.612	4.967	6.385	19.287	16.50
800	55	150	45	90	155	310	620	1240	5.387	5.742	7.160	7.936	19.00
1000	65	200	55	110	—	212	424	848	—	6.517	7.936	24.189	21.50
1200	75	200	65	130	—	—	420	840	—	—	21.577	27.251	24.00
1500	90	300	80	150	—	—	280	560	—	—	25.253	30.927	25.75

Motor Characteristics

	M01x M02x SM232AE	M11x M12x SM232AQ	M03x SM233AE	M13x SM233AQ	M04x MPP921B	M14x MPP921B	M100 Series* HV232	M100 Parallel* HV232
Max. Voltage	340	340	340	340	340	340	170	170
Peak Current	8.3	8.3	8.1	8.1	7.0	7.0	1.38	2.76
RMS Current	2.0	2.0	1.9	1.9	1.8	1.8	1.38	2.76
Resistance	7.50	7.50	9.65	9.65	11.0	11.0	3.41	0.85
Inductance	2.90	2.90	4.08	4.08	47.0	47.0	12.28	3.07
Recommended Drive	S025	AR-04	S025	AR-04	S025	AR-04	E-AC	E-AC

* Series/Parallel denotes wiring of step motor to drive

(1) Accuracy and Repeatability apply to in-line motors only. Contact factory for parallel motor configurations. The accuracy and repeatability shown are for mechanics only and assume no error contribution from the motor. With standard 4000 count encoders an additional error must be added to both the accuracy and repeatability. For 5 mm lead add 1.25 microns, for 10 mm leads add 2.5 microns and for 20 mm leads add 5 microns of error to the accuracy and repeatability value stated above.

(2) Normal load capacities apply to centralized load on the linear bearing to a life of 2540 Km. Refer to life/load charts to determine life of your particular application. Normal load capacity ratings are to be used as a reference of linear bearing load to life rating. This value SHOULD NOT be used as a safe loading value since other application factors (such as mounting) affect the safe load rating.

(3) Axial load capacities assumes an average axial load on a 10 mm lead ball screw and a life of 2540 Km. Refer to life/load charts to determine life of your particular application.



HD125 Series Performance

HD125 Thrust versus Velocity

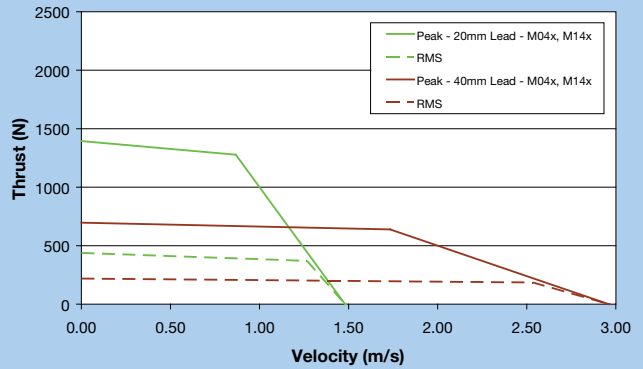
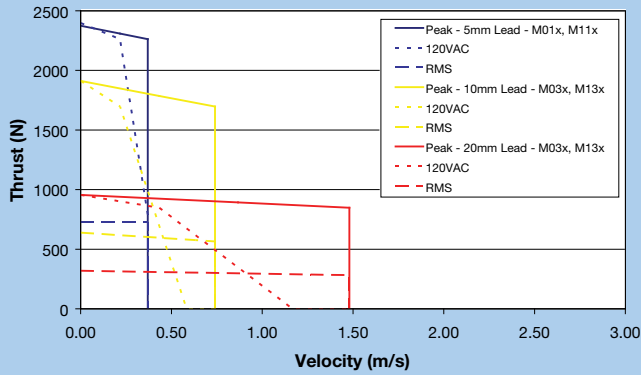

Screw Driven Tables

HD125 Inertia Ratios

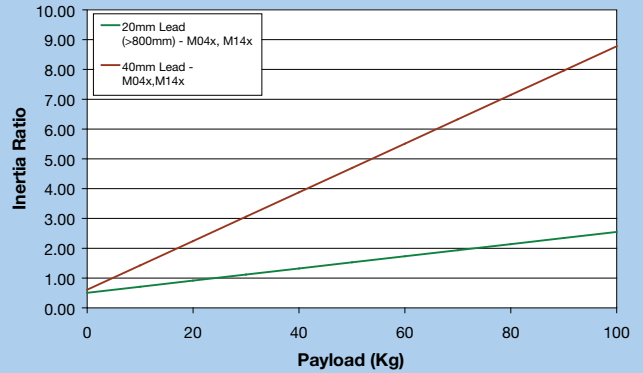
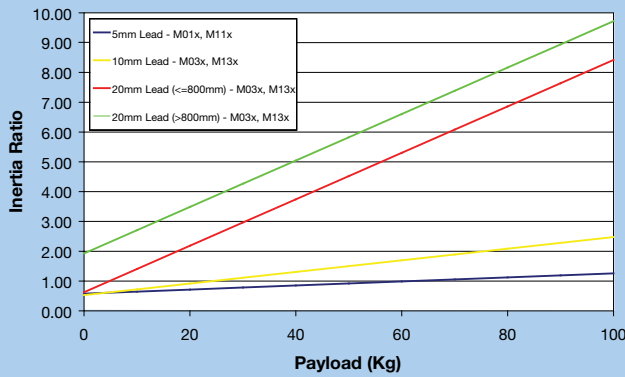

HD125 Acceleration Rates

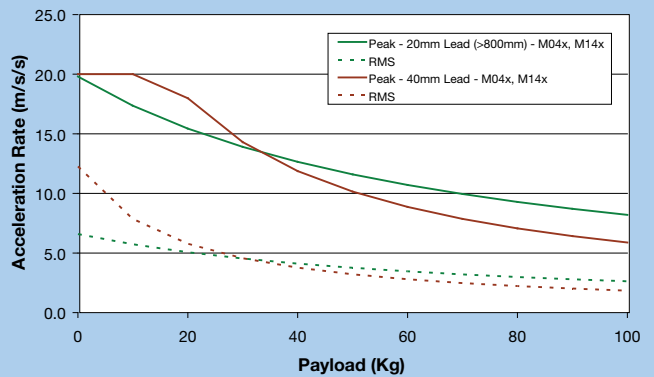
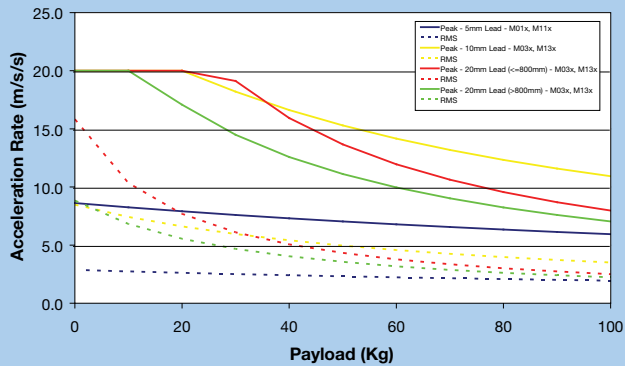

HD185 Series Linear Table
185 mm Wide Profile

Common Characteristics

Performance	Standard	Industrial
Bidirectional Repeatability ⁽¹⁾ – (µm)	±8.0	±50.0
Duty Cycle	100%	100%
Max Acceleration – m/sec ² (in/sec ²)	20 (773)	20 (773)
Rated Normal Load ⁽²⁾ – kgf (lbs)	1470 (3241)	1470 (3241)
Rated Axial Loading ⁽³⁾ – kgf (lbs)	90 (198)	90 (198)
Drive Screw Efficiency – %	90	90
Max. Breakaway Torque – Nm (ft-lbs)		
0 to 1000 mm Travel	0.32 (0.24)	0.32 (0.24)
1200 to 1600 mm Travel	0.38 (0.28)	0.38 (0.28)
Running Torque – Nm (ft-lbs)		
0 to 1000 mm Travel	0.21 (0.15)	0.21 (0.15)
1200 to 1600 mm Travel	0.35 (0.26)	0.35 (0.26)
Linear Bearing Coefficient of Friction	0.01	0.01
Carriage Weight – kg (lbs)	3.6 (7.92)	3.6 (7.92)



Travel Dependent Characteristics

Travel	Positional Accuracy ⁽¹⁾ (µm)		Straightness & Flatness Accuracy (µm)		Max. Velocity (mm/sec.) @ Specified Lead				Input Inertia (kg-m ² x 10 ⁻⁹) @ Specified Lead				Weight (kg) Total
	Std	Ind	Std	Ind	5 mm	10 mm	20 mm	40 mm	5 mm	10 mm	20 mm	40 mm	
300	30	75	20	40	370	740	1480	2240	3.446	4.174	7.087	23.178	22.9
400	35	100	25	50	370	740	1480	2240	3.833	4.562	7.475	24.403	24.6
500	40	120	30	60	355	710	1420	2240	4.221	4.949	7.862	25.628	26.4
600	45	130	35	70	270	540	1080	2000	4.609	5.337	8.250	26.854	28.2
800	55	150	45	90	165	330	660	1320	5.384	6.112	9.025	29.304	31.7
1000	65	200	55	110	—	230	460	920	—	6.888	9.801	31.754	35.2
1200	75	235	65	130	—	—	440	880	—	—	22.253	34.205	38.7
1400	85	250	75	150	—	—	340	680	—	—	25.003	36.655	42.2
1600	95	300	85	180	—	—	260	520	—	—	27.454	39.106	45.8

Motor Characteristics

	M01x SM232AE	M11x SM232AQ	M03x SM233AE	M13x SM233AQ	M04x MPP921B	M14x MPP921B
Max. Voltage	340	340	340	340	340	340
Peak Current	8.3	8.3	8.1	8.1	7.0	7.0
RMS Current	2.0	2.0	1.9	1.9	1.8	1.8
Resistance	7.50	7.50	9.65	9.65	11.0	11.0
Inductance	2.90	2.90	4.08	4.08	47.0	47.0
Recommended Drive	S025	AR-04	S025	AR-04	S025	AR-04

* Series/Parallel denotes wiring of step motor to drive

(1) Accuracy and Repeatability apply to in-line motors only. Contact factory for parallel motor configurations. The accuracy and repeatability shown are for mechanics only and assume no error contribution from the motor. With standard 4000 count encoders an additional error must be added to both the accuracy and repeatability. For 5 mm lead add 1.25 microns, for 10 mm leads add 2.5 microns and for 20 mm leads add 5 microns of error to the accuracy and repeatability value stated above.

(2) Normal load capacities apply to centralized load on the linear bearing to a life of 2540 Km. Refer to life/load charts to determine life of your particular application. Normal load capacity ratings are to be used as a reference of linear bearing load to life rating. This value SHOULD NOT be used as a safe loading value since other application factors (such as mounting) affect the safe load rating.

(3) Axial load capacities assumes an average axial load on a 10 mm lead ball screw and a life of 2540 Km. Refer to life/load charts to determine life of your particular application.



HD185 Series Performance

HD185 Thrust versus Velocity

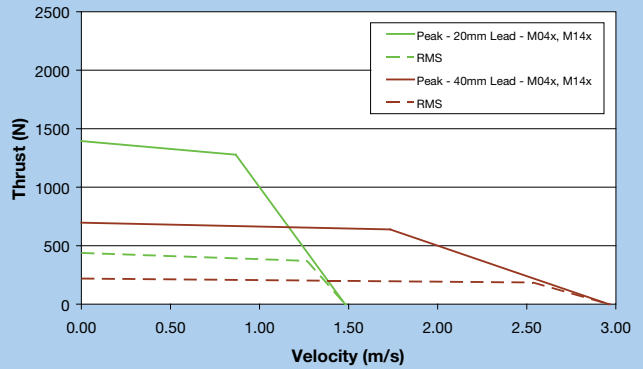
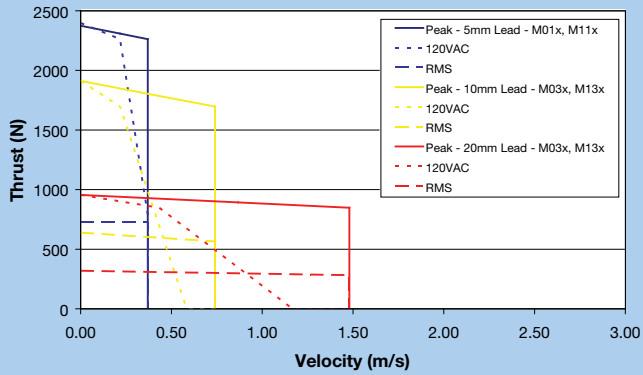

Screw Driven Tables

HD185 Inertia Ratios

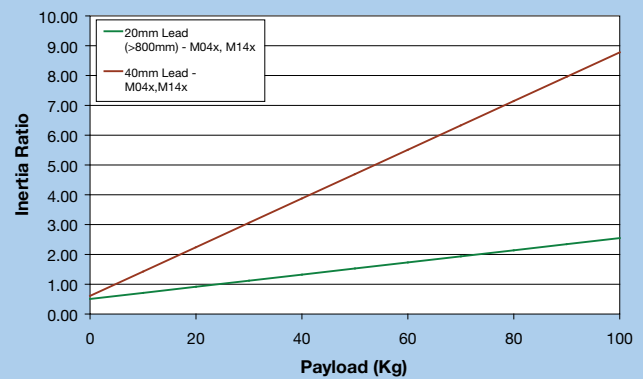
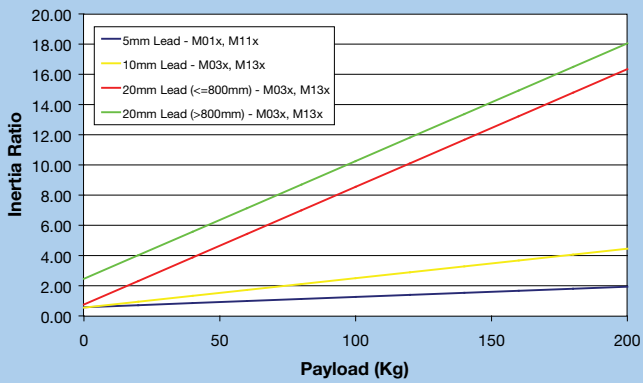

HD185 Acceleration Rates

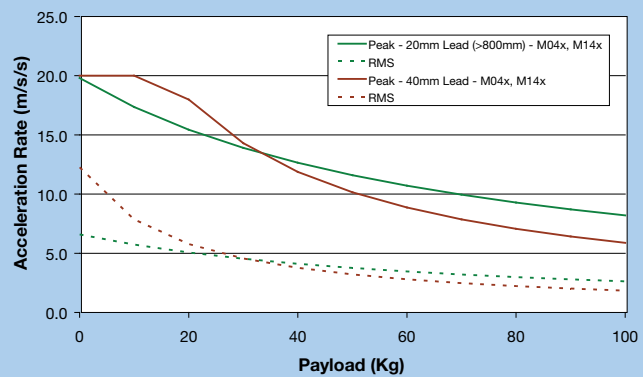
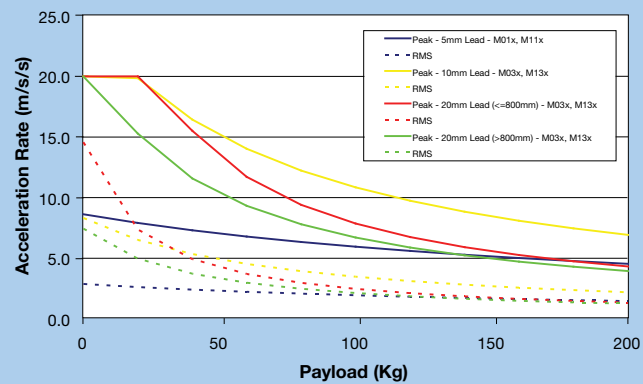

HD Series Features and Options

Deep Channel Extruded Body

The foundation of the HD Series is an extruded body, designed to provide exceptional beam strength and rigidity with ease of use features, yet be aesthetically appealing. The extrusion cross section has a high moment of inertia that strengthens and stiffens the unit. This enables users to span unsupported distances or cantilever the axis with minimal or no need for stiffening brackets. As an example, an HD may be toe clamped directly to the structural beams in a machine frame as opposed to having a plate cut to size and machined flat to serve as the positioner's mounting surface. The elimination of the mounting plate reduces overall design time and machine cost.



Precision Machined Tolerances

The extruded base provides the basic shape of the positioner but in its raw form, lacks the precision needed for most applications. Parker's proprietary machining processes are used to cut rail seats and flatten the bottom of the extrusion to specifications better than jig plate. Some manufacturers will skip machining the bottom mounting surface to save cost but sacrifice precision and risk binding and other application problems. With the HD Series you gain the feature benefits of an extruded base and through Parker's machining capability, gain precision better than jig plate designs can offer.



Maintenance Free Linear Bearings

Supporting the payload in the HD Series is a precision ground linear bearing set that offers precise, smooth motion. The two-rail, four-bearing truck design provides high load capacity and is structured to handle cantilevered load unlike single rail designs. The linear bearings are self lubricating and therefore will not require re-lubrication for the life of the table.



IP30 Rated Environmental Protection

Often automation applications can be in dirty environments. For this reason the HD Series includes environmental protection beyond just a simple plate. The HD Series uses a combination of hard cover and belt seal to provide a significant level of environmental protection for the tables internal components. This is ideal for larger objects like nuts, bolts, fingers, and larger debris. The sealing system will provide a measure of protection for dust but is not impervious. For these applications, pressurizing the HD positioner can be very effective.



High-Performance Brushless Servo Motors

Included with the HD Series are high-performance brushless servo motors. These motors are performance-matched with the mechanical drive train and are inertia matched to maintain good load-to-rotor inertia ratios. Together, these characteristics offer excellent dynamic performance and stability.



As standard, the motors are offered in an in-line configuration and for space constrained applications may be mounted in a parallel configuration. The parallel design utilizes a belt and pulley to transfer torque and includes additional pulley support bearings to protect the motor shaft and screw shank from over tension and fatigue failures.

Finally, because the motors are included, system performance can be pre-calculated and presented in graphical form. For most applications, motor sizing is as simple as looking at a graph.

Zero Backlash Shaft Coupling

Included with the HD Series to transfer motor torque to the ballscrew is a high-performance shaft coupling. The coupling design uses stainless steel disks to transfer torque yet provide a measure of flexibility for slight shaft misalignments. The design is very lightweight and adds minimal inertia. The combination of high stiffness and low inertia maintains high natural frequencies, which is important for high performance applications.





Ground Ballscrew Drive Train (Standard Grade)

At the heart of the HD Series drive train is a preloaded, precision ground ballscrew. This high-performance component offers high-speed, 100% duty cycle operation with long life, plus the better precision and surface finish of a ground screw compared with a rolled screw enables more accurate and quieter operation.



As standard, the HD Series offers 5 mm, 10 mm, and 20 mm lead options with a 40 mm lead available as a special. For most travels, the screws are 15 mm in diameter with the longer 20 mm lead and all 40 mm lead screws increasing to 20 mm in diameter. Like the linear bearings, the screws are self lubricating and will not require re-lubrication for the table's life.

Mounting Features

The HD Series is designed for easy mounting. There are two basic methods of mounting an HD module into a machine. First, toe clamps (Part Number 101-2577-01) provide an easy method of bolting the HD down to a surface. For maximum flexibility, the toe clamps can be placed anywhere along the body extrusion and enable aligning mounting points with structural members of the machine frame. The second method utilizes tapped holes in the base where the mounting hardware comes through the mounting surface into the HD module. The mounting pattern consists 4 tapped holes and 2 dowel holes and repeats at varying intervals depending on overall travel. See the HD Series drawings for hole location details.



Dowel Holes

As mentioned above the base of the HD Series includes dowel holes. These enable repeatable mounting within a machine. Further, the carriage of the HD also includes a set of dowel holes and is very useful for maintaining alignment if the payload is removed or replaced.



End Mounting

In many applications, the positioner may be mounted with the carriage stationary such that the body moves. For these applications, the end of the HD includes tapped and dowel holes for mounting of the payload to the HD body. In many cases this avoids the cost and time of designing an awkward bracket to wrap from the bottom of the positioner around to the end.



Home and Limit Sensors

As a standard option, home and end of travel limit sensors may be added to an HD positioner. These are industrially hardened, hall effect sensors that are triggered by a magnet mounted on the moving carriage. The sensors nest inside the extrusion T-slot and so do not add additional width or create obstructions. Further they are protected inside the T-slot which minimizes the opportunity for physical damage.



For maximum flexibility, sensors are adjustable over the entire length and magnets are included on both sides of the table so sensors can be attached on either side. The sensors are offered in 4 variants with NPN (sinking) or PNP (sourcing) outputs and in normally open (NO) or normally closed (NC) logic. The sensor cables extend 300 mm and terminate into a M3 connector. If purchased as part of the positioner (LH option) each sensor will include a 5 m extension cable (P/N: 003-2918-01).

Input Power	10-30VDC
Voltage Drop	<= 2.5V
Cont. Current	100mA
Electrical Protection	Short Circuit, Reverse Polarity, Power Up Pulse Suppression
Enclosure	IP67 Rated Polyamide Housing with PVC Cable Jacket
Wire Colors	Brown – Power (+) Black – Signal Blue – Ground (-)
Repeatability	0.1 mm max

Spare Part Number	Output Type	Logic	Cable Type
P8S-GNCHX	N.O.	NPN (Sinking)	300 mm to M3 connector
P8S-GPCHX	N.O.	PNP (Sourcing)	300 mm to M3 connector
P8S-GMCHX	N.C.	NPN (Sinking)	300 mm to M3 connector
P8S-GQCHX	N.C.	PNP (Sourcing)	300 mm to M3 connector
003-2918-01	—	—	5.0 m Extension Cable

Screw Driven Tables

HD085 Series Dimensions

Dimensions (mm)

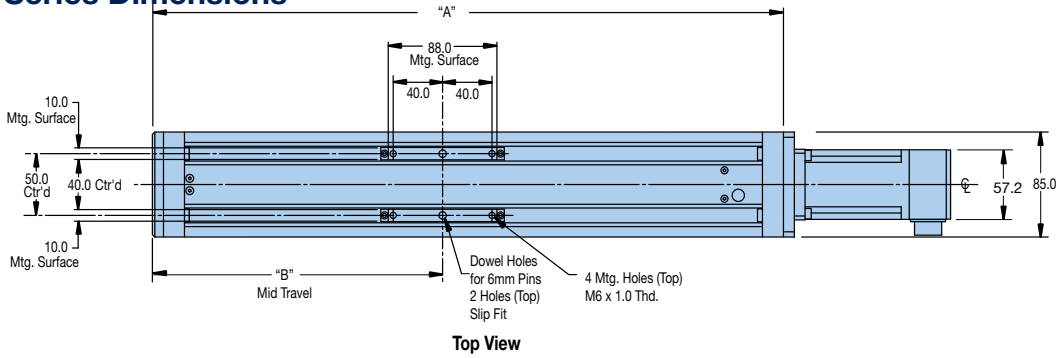

Top View

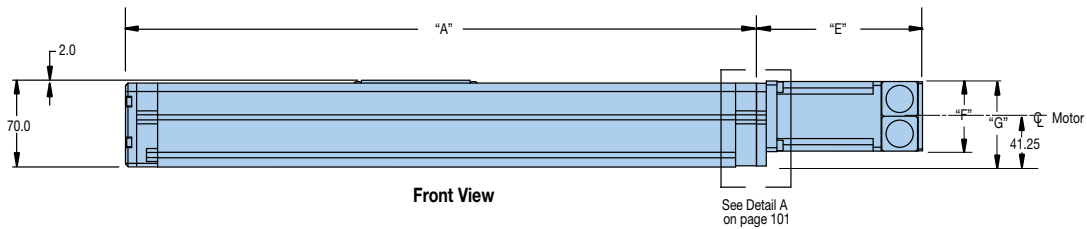

Front View

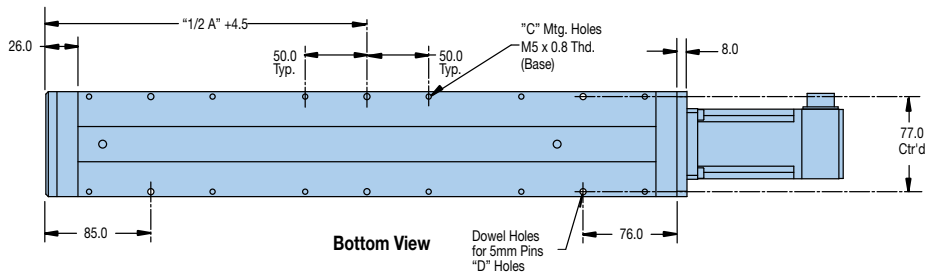

Bottom View

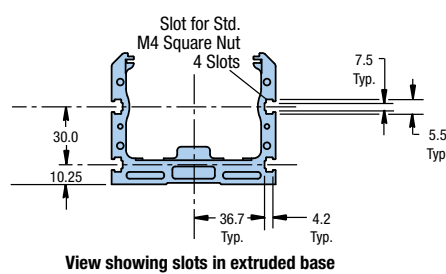
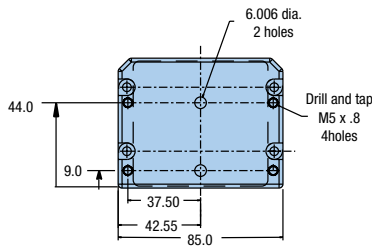

View showing slots in extruded base

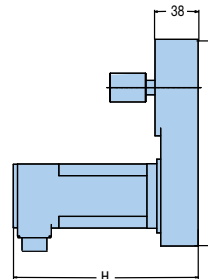

Parallel Motor Mounts for "M" Motor Codes Shown in Position A

Dimensions						
Model	Travel	A	B	C	D	E
HD085T01	100	311	135	4	2	160
HD085T02	200	411	185	12	6	210
HD085T03	300	511	235	12	6	260
HD085T04	400	611	285	12	6	310
HD085T05	500	711	335	12	6	360
HD085T06	600	811	385	12	6	410
HD085T07	700	911	435	12	6	460
HD085T08	800	1011	485	12	6	510
HD085T09	900	1111	535	12	6	560
HD085T10	1000	1211	585	12	6	610
HD085T11	1100	1311	635	12	6	660
HD085T12	1200	1411	685	12	6	710

Dimensions					
Motor Model		E	F	G	H
M000	No Motor	0	-	-	-
M010	SM232AE-TPSN	134.5	57.2	69.8	163
M020	SM232AE-TPSB	168.0	57.2	69.8	198
M100	HV232-D2-10	79.2	57.2	69.8	-
M110	SM232AQ-TPSN	134.5	57.2	69.8	163
M020	SM232AQ-TPSB	168.0	57.2	69.8	198



HD085 Parallel Motor Options

Dimensions (mm)

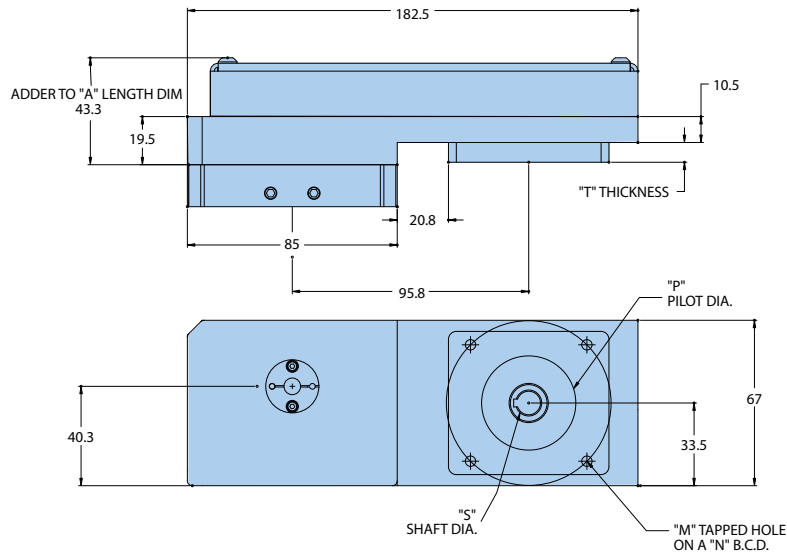

NOTE : SHOWN AS SIDE "A" ("B" IS MIRROR IMAGE . ROTATED 180° ABOUT TABLE SCREW CENTERLINE)

Motor Adapter Assembly Part Number	Dimensions				Example Motors
	M	P	S	T	
A011-HD085 or B011-HD085	M4 x 0.7	30.0	8.0	6.5	Yaskawa SGMAH-01, SGM-01 Kollmorgen AKM1X-AN Allen Bradley Y-1002, Y-1003
A232-HD085 or B232-HD085	M5 x 0.8	38.1	9.53	8.0	Parker SM23X , BE23X

Screw Driven
Tables

HD085 Motor Flange/Coupling Assembly Options

Dimensions (mm)

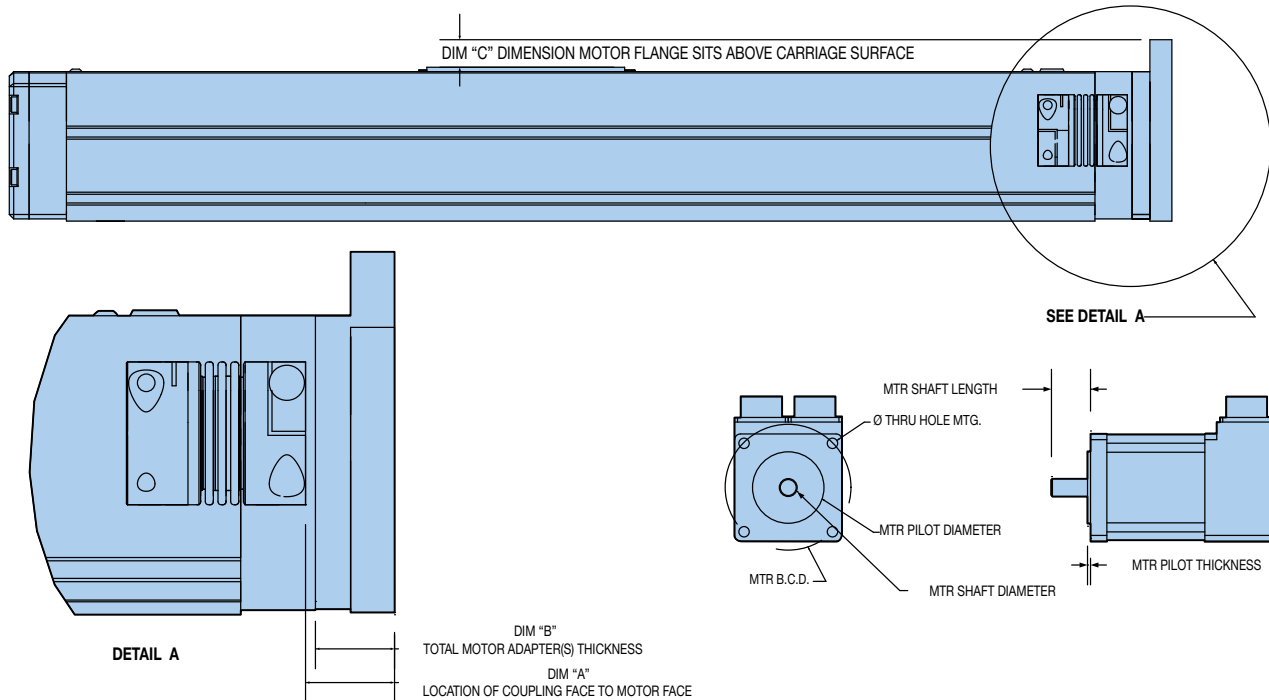

Motor Adapter Assembly Part Number	Dimensions			Required Motor Specifications						Example Motors
	A	B	C	Pilot Dia.	Pilot Depth	Bolt Circle Dia.	Bolt Hole Size	Shaft Dia.	Shaft Length	
F011-HD085	12.0	8.0	—	30.0	3.0	46.0	4.5	8.0	25.0	Yaskawa SGMAH-01, SGM-01 Kollmorgen AKM1X-AN Allen Bradley Y-1002, Y-1003
F012-HD085	12.0	8.0	—	30.0	3.0	46.0	4.5	6.0	25.0	Yaskawa SGMAH-A1XXF4, SGMAH-A3XXF4X, SGM-03,SGM-A5
F021-HD085	15.0	10.5	—	50.0	3.0	60.0	4.5	8.0	24.0	Allen Bradley LD-2003 Parker SMB60/HDY55
F031-HD085	12.0	8.0	—	40.0	3.0	63.0	5.5	9.0	20.0	Allen Bradley MPL1510/1520/1530 Kollmorgen AKM2X-AN Indramat MKD025
F041-HD085	12.0	8.0	—	40.0	3.0	63.0	4.5	9.0	20.0	Yaskawa SGMP-01, SGMPH-01-XXXX
F051-HD085	15.0	10.5	—	50.0	3.0	70.0	5.5	8.0	25.0	Yaskawa SGMAH-02XXF4X, SGMAH-04XXF4X, SGM-02, SGM-04
F061-HD085	20.0*	18.0	1.3	50.0	3.0	70.0	5.5	14.0	30.0	Allen Bradley Y-2006, Y-2012 Parker J070/NO70/HDY70
F071-HD085	10.0*	10.5	2.0	60.0	3.0	75.0	5.5	11.0	23.0	Allen Bradley MPL210/220/230 Kollmorgen B102/BH-122
F072-HD085	10.0*	10.5	2.0	60.0	3.0	75.0	5.5	14.0	30.0	Kollmorgen B104/B106, M-103/105/107, AKM3X-AN, BH-124/126
N231-HD085	12.0	8.0	—	38.1	3.0	66.675	5.5	6.35	20.0	Parker ES23X Allen Bradley N-2302, N-2304
N232-HD085	12.0	8.0	—	38.1	3.0	66.675	5.5	9.525	20.0-31.0	Animatics SM2310D, SM2320D Parker SM23X , BE23X
N233-HD085	10.0*	8.0	—	38.1	3.0	66.675	4.5	12.7	20.0	Yaskawa SGMAH-0XXN2XX, SGMAH-04XXN2XX NEMA 23 Face
N341-HD085	20.0*	18.0	12.6	73.03	3.0	98.425	5.5	12.5	37.0	Parker HV/LV34

* Note: Coupling must be mounted to motor first. Distance of coupling face to motor face.



HD125 Series Dimensions

Dimensions (mm)

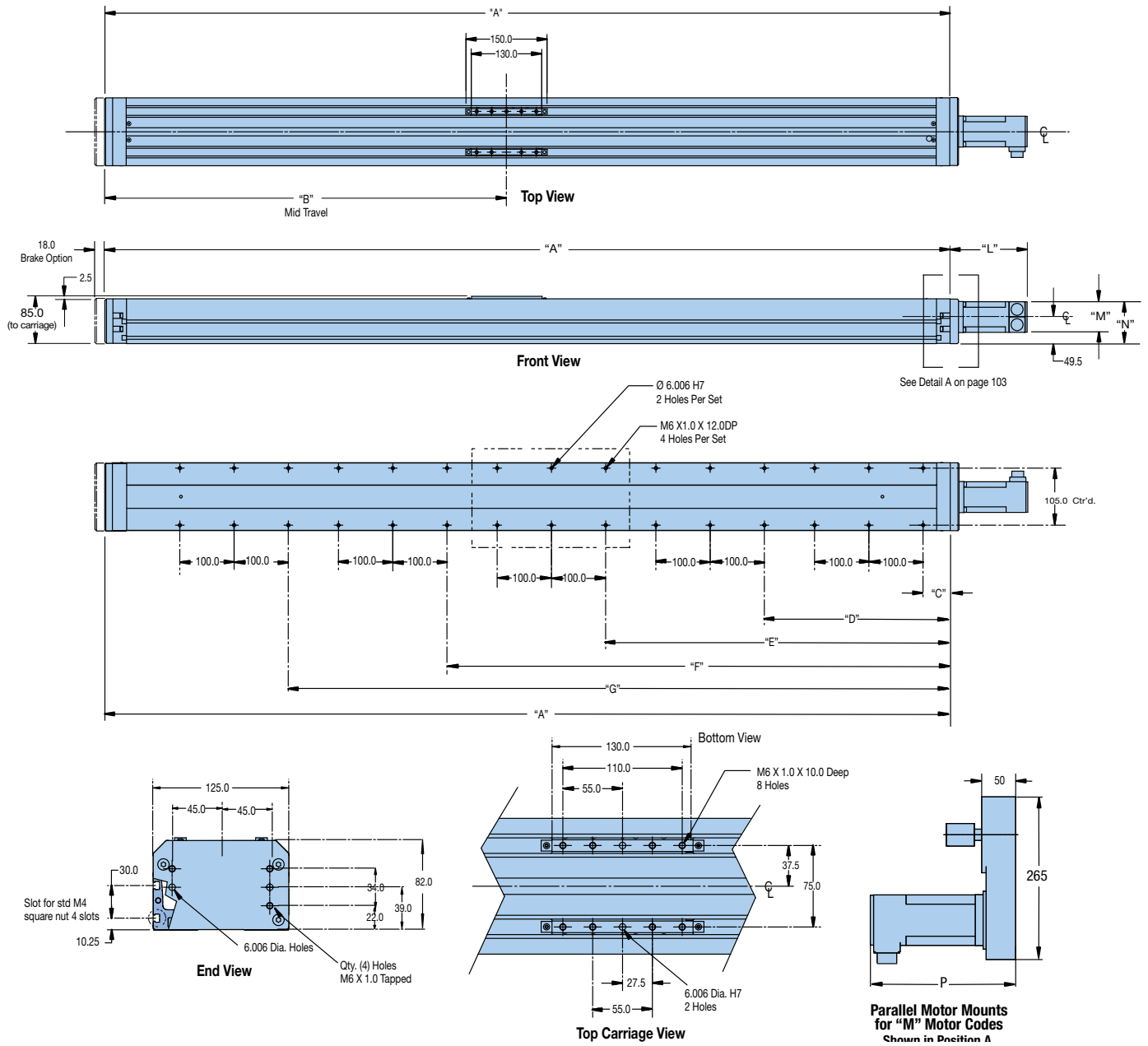

Dimensions								
Model	Travel	A	B	C	D	E	F	G
HD125T02	200	508.0	239.5	-	-	135.0	-	-
HD125T03	300	608.0	289.5	50.0	-	185.0	-	320.0
HD125T04	400	708.0	339.5	50.0	-	235.0	-	420.0
HD125T05	500	808.0	389.5	50.0	-	285.0	-	520.0
HD125T06	600	908.0	439.5	50.0	-	335.0	-	620.0
HD125T08	800	1108.0	539.5	50.0	-	435.0	-	820.0
HD125T10	1000	1308.0	639.5	50.0	-	535.0	-	1020.0
HD125T12	1200	1558.0	737.0	50.0	342.5	635.0	927.5	1220.0
HD125T15	1500	1858.0	887.0	50.0	417.5	785.0	1152.5	1520.0

Dimensions					
Motor Model		L	M	N	P
M000	No Motor	0	-	-	-
M010	SM232AE-TPSN	167	57.2	78.1	208
M030	SM233AE-TPSN	192	57.2	78.1	233
M040	CMP921B1E	195	89.4	94.2	-
M100	HV232-D2-10	102	57.2	78.1	-
M110	SM232AE-TPSN	167	57.2	78.1	208
M130	SM233AE-TPSN	192	57.2	78.1	233
M140	CMP921B3E	195	89.4	94.2	-



HD125 Parallel Motor Options

Dimensions (mm)

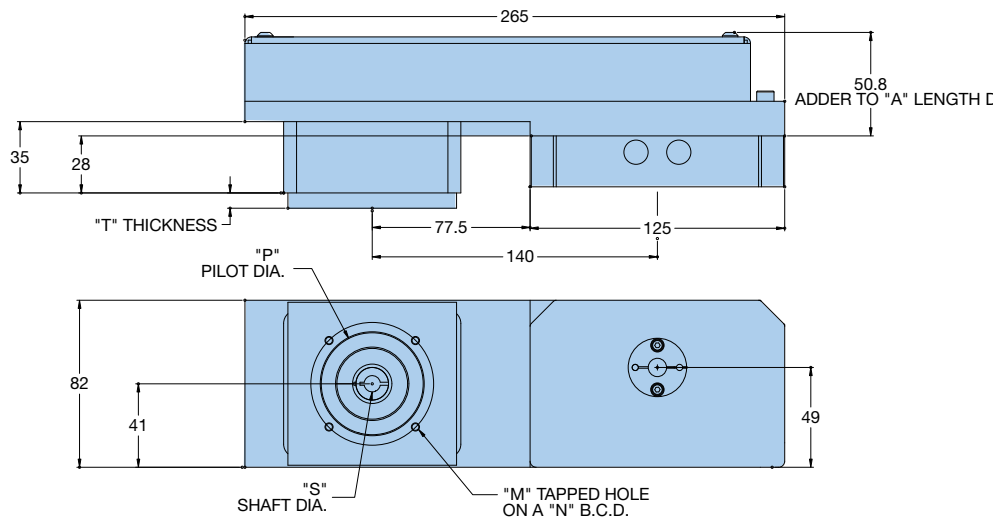

NOTE : SHOWN AS SIDE"B" ("A" IS MIRROR IMAGE . ROTATED 180' ABOUT TABLE SCREW CENTERLINE)

Motor Adapter Assembly Part Number	Dimensions					Example Motors
	M	N	P	S	T	
A021-HD125 or B021-HD125	M4 x 0.7	60.0	50.0	8.0	7.5	Allen Bradley LD-2003
A031-HD125 or B031-HD125	M5 x 0.8	63.0	40.0	9.0	7.5	Parker SMB60/HDY55 Allen Bradley MPL1510/1520/1530
A041-HD125 or B041-HD125	M4 x 0.7	63.0	40.0	9.0	7.5	Kollmorgen AKM2X-AN Indramat MKD025
A061-HD125 or B061-HD125	M5 x 0.8	70.0	50.0	8.0	10.0	Yaskawa SGMP-01, SGMPH-01-XXXX
A062-HD125 r B062-HD125	M5 x 0.8	70.0	50.0	14.0	10.0	Yaskawa SGMAH-02XXF4X, SGMAH-04XXF4X, SGM-02, SGM-04 Allen Bradley Y-2006, Y-2012
A071-HD125 or B071-HD125	M5 x 0.8	75.0	60.0	11.0	-	Parker J070/NO70/HDY70 Allen Bradley MPL210/220/230 Kollmorgen B102/BH-122
A081-HD125 or B081-HD125	M6 x 1.0	90.0	70.0	14.0	10.0	Yaskawa SGMPH-02XXX, SGMPH-04XXX, SGMP-02, SGMP-04
A101-HD125 or B101-HD125	M6 x 1.0	95.0	50.0	14.0	10.0	Indramat MKD041
A111-HD125 or B111-HD125	M6 x 1.0	100.0	80.0	14.0	10.0	Parker JO92X/NO92X
A121-HD125 or B121-HD125	M6 x 1.0	100.0	80.0	16.0	8.0*	Kollmorgen AKM4X-AN Mounting Code
A231-HD125 or B231-HD125	M5 x 0.8	66.68	38.1	6.35	10.0	Parker ES23X Allen Bradley N-2302, N-2304 Animatics SM2310D, SM2320D
A232-HD125 or B232-HD125	M5 x 0.8	66.68	38.1	9.53	10.0	Parker SM23X , BE23X
A233-HD125 or B233-HD125	M4 x 0.7	66.68	38.1	12.7	10.0	Yaskawa SGMAH-0XXN2XX, SGMAH-04XXN2XX NEMA 23 Face
A341-HD125 or B341-HD125	M5 x 0.8	98.43	73.03	6.35	15.0	Parker HV/LV34
A342-HD125 or B342-HD125	M5 x 0.8	98.43	73.03	12.7	15.0	Parker BE34

*Not outer support bearing assembly block (no 35 mm dimension pulley on motor shaft).

* Note: Coupling must be mounted to motor first. Distance of coupling face to motor face.

HD125 Motor Flange/Coupling Assembly Options

Dimensions (mm)

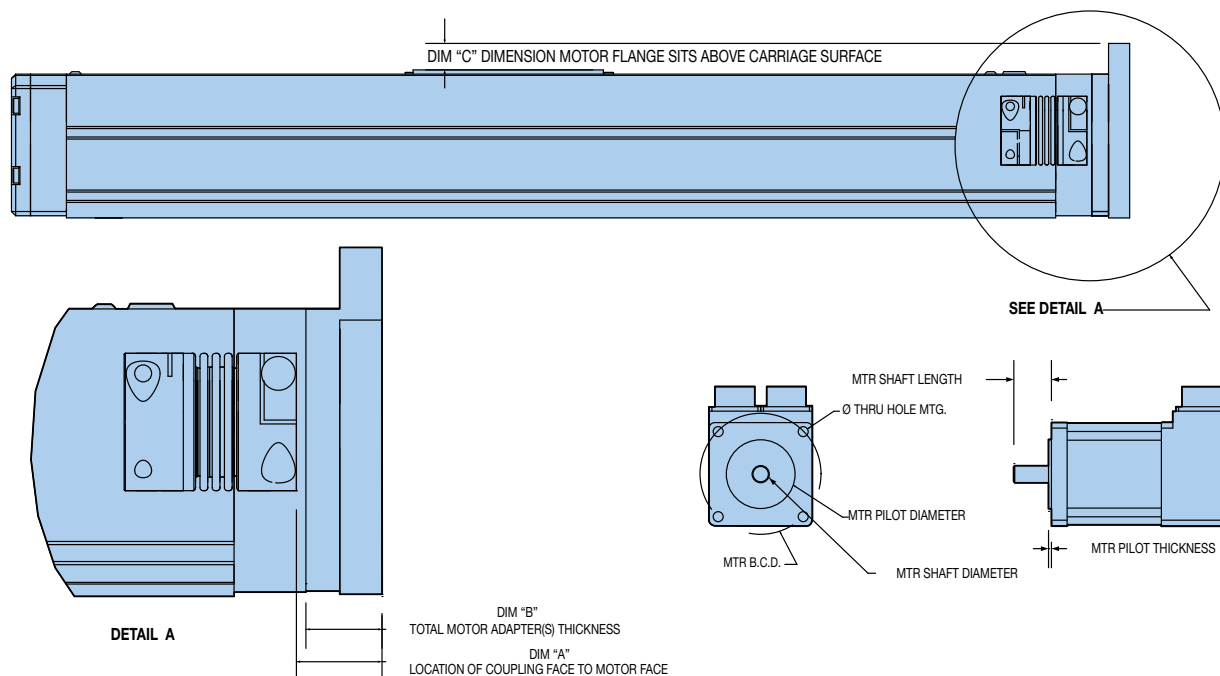

Motor Adapter Assembly Part Number	Dimensions			Required Motor Specifications						Example Motors
	A	B	C	Pilot Dia.	Pilot Depth	Bolt Circle Dia.	Bolt Hole Size	Shaft Dia.	Shaft Length	
F021-HD125	15.0	10.5	—	50.0	3.0	60.0	4.5	8.0	24.0	Allen Bradley LD-2003
F031-HD125	12.0	8.0	—	40.0	3.0	63.0	5.5	9.0	20.0	Parker SMB60/HDY55 Allen Bradley MPL1510/1520/1530
F041-HD125	12.0	7.5	—	40.0	3.0	63.0	4.5	9.0	20.0	Kollmorgen AKM2X-AN Indramat MKD025
F061-HD125	15.0	12.0	—	50.0	3.0	70.0	5.5	8.0	25.0	Yaskawa SGMP-01, SGMPH-01-XXXX
F062-HD125	15.0	12.0	—	50.0	3.0	70.0	5.5	14.0	30.0	Yaskawa SGMAH-02XXF4X, SGMAH-04XXF4X, SGM-02, SGM-04 Allen Bradley Y-2006, Y-2012
F071-HD125	12.0	10.5	—	60.0	3.0	75.0	5.5	11.0	23.0	Parker J070/NO70/HDY70 Allen Bradley MPL210/220/230 Kollmorgen B102/BH-122
F072-HD125	12.0	10.5	—	60.0	3.0	75.0	5.5	14.0	30.0	Kollmorgen B104/B106, M-103/105/107, AKM3X-AN, BH-124/126
F081-HD125	15.0*	22.0	4.5	70.0	3.5	90.0	6.6	14.0	30.0	Yaskawa SGMPH-02XXX, SGMPH-04XXX, SGMP-02, SGMP-04
F082-HD125	15.0*	22.0	4.5	70.0	3.5	90.0	6.6	16.0	30.0-40.0	Yaskawa SGMAH-08 SGM-08 Allen Bradley Y-3023
F091-HD125	15.0*	22.0	4.5	70.0	3.5	90.0	5.5	14.0	30.0	Allen Bradley LD-3009
F101-HD125	15.0*	22.0	7.0	50.0	3.5	95.0	6.6	14.0	30.0	Indramat MKD041
F111-HD125	15.0*	20.0	7.0	80.0	3.5	100.0	6.6	14.0	30.0	Parker JO92X/NO92X
F121-HD125	20.0*	28.0	7.0	80.0	3.5	100.0	6.6	16.0	30.0-40.0	Parker MPP92X Allen Bradley MPL310/320/330, LD-4012
F122-HD125	25.0*	33.0	7.0	80.0	3.5	100.0	6.6	19.0	40.0	Kollmorgen AKM4X-AN Mounting Code
N231-HD125	12.0	8.0	—	38.1	3.0	66.675	5.5	6.35	20.0	Parker ES23X Allen Bradley N-2302, N-2304 Animatics SM2310D, SM2320D
N232-HD125	12.0	8.0	—	38.1	3.0	66.675	5.5	9.525	20.0-31.0	Parker SM23X, BE23X
N233-HD125	10.0*	8.0	—	38.1	3.0	66.675	4.5	12.7	20.0	Yaskawa SGMAH-0XXN2XX, SGMAH-04XXN2XX NEMA 23 Face
N341-HD125	15.0	20.0	7.0	73.03	3.0	98.425	5.5	12.5	37.0	Parker HV/LV34
N342-HD125	15.0*	20.0	7.0	73.03	3.0	98.425	5.5	12.7	30.0	Parker BE34



HD185 Series Dimensions

Dimensions (mm)

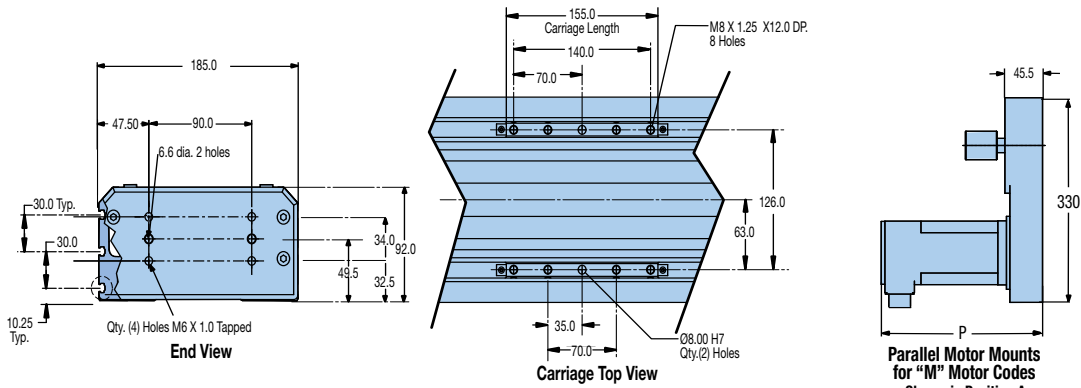
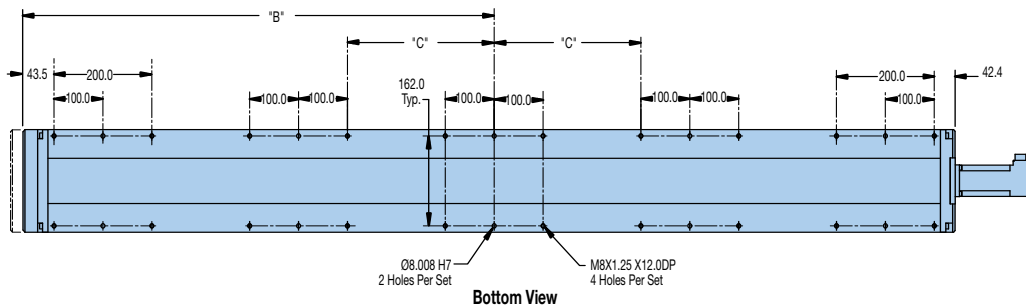
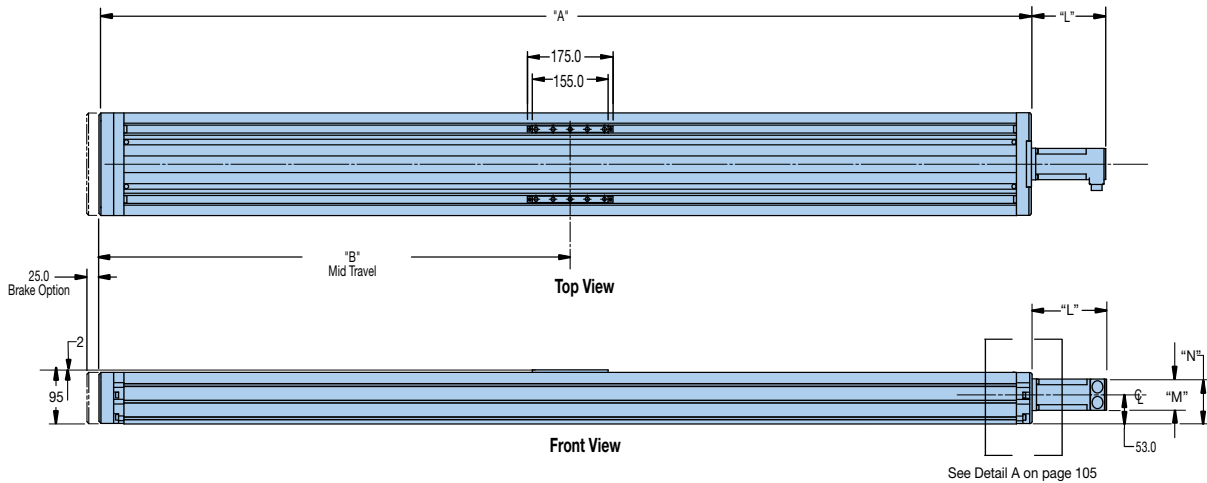

Model	Travel	Dimensions		
		A	B	C
HD185T03	300	585.9	293.5	—
HD185T04	400	685.9	343.5	—
HD185T05	500	785.9	393.5	—
HD185T06	600	885.9	443.5	—
HD185T08	800	1085.9	543.5	—
HD185T10	1000	1285.9	643.5	—
HD185T12	1200	1485.9	743.5	200.0
HD185T14	1400	1685.9	843.0	250.0
HD185T16	1600	1885.9	943.0	300.0
HD185T18	1800	2085.9	1043.0	350.0
HD185T20	2000	2285.9	1143.5	400.0

Motor Model	Motor Model	Dimensions			
		L	M	N	P
M000	No Motor	0	—	—	—
M010	SM232AE-TPSN	126.8	57.2	81.6	208
M030	SM233AE-TPSN	152.2	57.2	81.6	233
M040	CMP921B1E	170.1	89.4	91.7	207
M110	SM232AQ-TPSN	126.8	57.2	81.6	208
M130	SM233AQ-TPSN	152.2	57.2	81.6	233
M140	CMP921B3E	170.1	89.4	91.7	277



New HD185 Parallel Motor Options

Dimensions (mm)

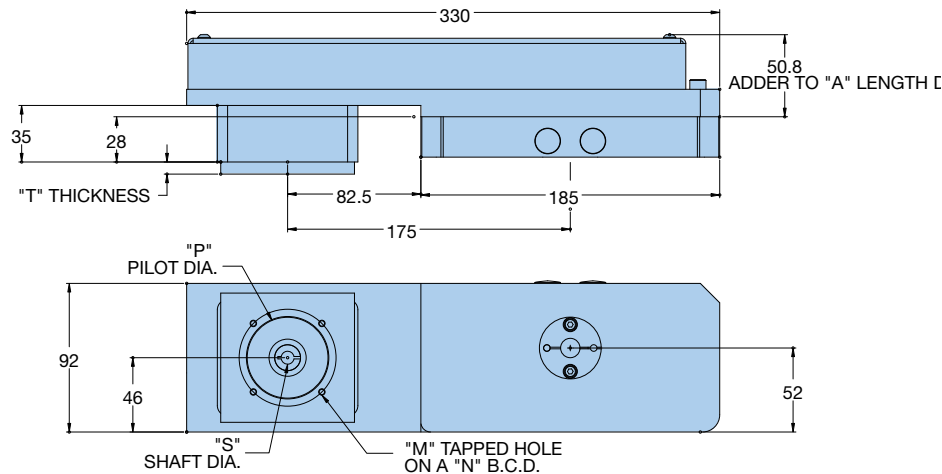

NOTE : SHOWN AS SIDE "B" ("A" IS MIRROR IMAGE . ROTATED 180° ABOUT TABLE SCREW CENTERLINE)

Screw Driven Tables

Motor Adapter Assembly Part Number	Dimensions					Example Motors
	M	N	P	S	T	
A021-HD185 or B021-HD185	M4 x 0.7	60.0	50.0	8.0	7.5	Allen Bradley LD-2003
A031-HD185 or B031-HD185	M5 x 0.8	63.0	40.0	9.0	7.5	Parker SMB60/HDY55 Allen Bradley MPL1510/1520/1530
A041-HD185 or B041-HD185	M4 x 0.7	63.0	40.0	9.0	7.5	Kollmorgen AKM2X-AN Indramat MKD025
A061-HD185 or B061-HD185	M5 x 0.8	70.0	50.0	8.0	10.0	Yaskawa SGMP-01, SGMPH-01-XXXX
A062-HD185 or B062-HD185	M5 x 0.8	70.0	50.0	14.0	10.0	Yaskawa SGMAH-02XF4X, SGMAH-04XF4X, SGM-02, SGM-04 Allen Bradley Y-2006, Y-2012
A071-HD185 or B071-HD185	M5 x 0.8	75.0	60.0	11.0	-	Parker J070/NO70/HDY70 Allen Bradley MPL210/220/230 Kollmorgen B102/BH-122
A081-HD185 or B081-HD185	M6 x 1.0	90.0	70.0	14.0	10.0	Yaskawa SGMPH-02XXX, SGMPH-04XXX, SGMP-02, SGMP-04
A082-HD185 or B082-HD185	M5 x 0.8	90.0	70.0	14.0	10.0	Yaskawa SGMAH-08 SGM-08 Allen Bradley Y-3023
A101-HD185 or B101-HD185	M6 x 1.0	95.0	50.0	14.0	10.0	Indramat MKD041
A111-HD185 or B111-HD185	M6 x 1.0	100.0	80.0	14.0	10.0	Parker JO92X/NO92X
A121-HD185 or B121-HD185	M6 x 1.0	100.0	80.0	16.0	8.0*	Parker MPP92X Allen Bradley MPL310/320/330, LD-4012
A231-HD185 or B231-HD185	M5 x 0.8	66.68	38.1	6.35	10.0	Parker ES23X Allen Bradley N-2302, N-2304 Animatics SM2310D, SM2320D
A232-HD185 or B232-HD185	M5 x 0.8	66.68	38.1	9.53	10.0	Parker SM23X , BE23X
A233-HD185 or B233-HD185	M4 x 0.7	66.68	38.1	12.7	10.0	Yaskawa SGMAH-0XXN2XX, SGMAH-04XXN2XX NEMA 23 Face
A341-HD185 or B341-HD185	M5 x 0.8	98.43	73.03	6.35	15.0	Parker HV/LV34
A342-HD185 or B342-HD185	M5 x 0.8	98.43	73.03	12.7	15.0	Parker BE34

*Not outer support bearing assembly block (no 35 mm dimension pulley on motor shaft).

HD185 Motor Flange/Coupling Assembly Options

Dimensions (mm)

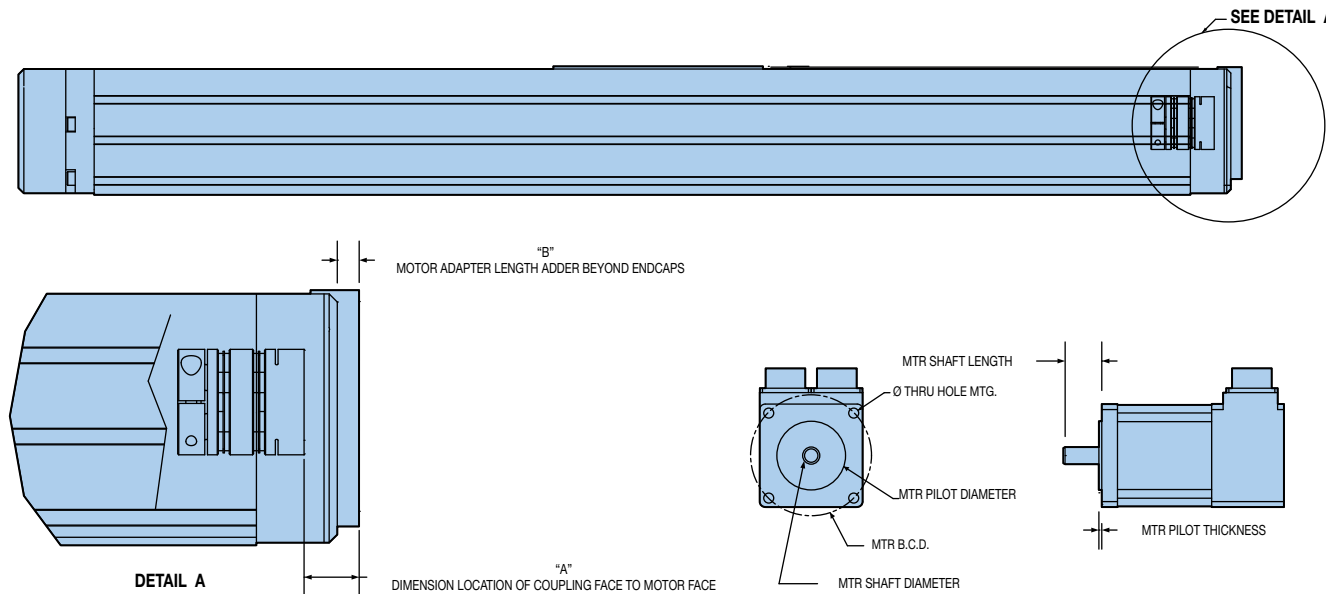

Motor Adapter Assembly Part Number	Dimensions		Required Motor Specifications						Example Motors
	A	B	Pilot Dia.	Pilot Depth	Bolt Circle Dia.	Bolt Hole Size	Shaft Dia.	Shaft Length	
F021-HD185	15.0	—	50.0	3.0	60.0	4.5	8.0	24.0	Allen Bradley LD-2003
F031-HD185	10.0	—	40.0	3.0	63.0	5.5	9.0	20.0	Parker SMB60/HDY55 Allen Bradley MPL1510/1520/1530
F041-HD185	10.0	—	40.0	3.0	63.0	4.5	9.0	20.0	Kollmorgen AKM2X-AN Indramat MKD025
F061-HD185	18.0	—	50.0	3.0	70.0	5.5	8.0	25.0	Yaskawa SGMP-01, SGMPH-01-XXXX
F062-HD185	18.0	—	50.0	3.0	70.0	5.5	14.0	30.0	Yaskawa SGMAH-02XXF4X, SGMAH-04XXF4X, SGM-02, SGM-04 Allen Bradley Y-2006, Y-2012
F071-HD185	10.0	—	60.0	3.0	75.0	5.5	11.0	23.0	Parker J070/NO70/HDY70 Allen Bradley MPL210/220/230 Kollmorgen B102/BH-122
F072-HD185	10.0	—	60.0	3.0	75.0	5.5	14.0	30.0	Kollmorgen B104/B106, M-103/105/107, AKM3X-AN, BH-124/126
F081-HD185	15.0	0.5	70.0	3.5	90.0	6.6	14.0	30.0	Yaskawa SGMPH-02XXX, SGMPH-04XXX, SGMP-02, SGMP-04
F082-HD185	15.0	0.5	70.0	3.5	90.0	6.6	16.0	30.0-40.0	Yaskawa SGMAH-08 SGM-08 Allen Bradley Y-3023
F083-HD185	20.0	0.5	70.0	3.5	90.0	5.5	14.0	30.0	Allen Bradley LD-3009
F101-HD185	12.0	0.5	50.0	3.5	95.0	6.6	14.0	30.0	Indramat MKD041
F111-HD185	15.0	0.5	80.0	3.5	100.0	6.6	14.0	30.0	Parker JO92X/NO92X
F121-HD185	20.0	8.0	80.0	3.5	100.0	6.6	16.0	30.0-40.0	Parker MPP92X Allen Bradley MPL310/320/330, LD-4012
F122-HD185	25.0	13.0	80.0	3.5	100.0	6.6	19.0	40.0	Kollmorgen AKM4X-AN Mounting Code
N231-HD185	12.0	—	38.1	3.0	66.675	5.5	6.35	20.0	Parker ES23X Allen Bradley N-2302, N-2304 Animatics SM2310D, SM2320D
N232-HD185	12.0	—	38.1	3.0	66.675	5.5	9.525	20.0-31.0	Parker SM23X, BE23X
N233-HD185	12.0	—	38.1	3.0	66.675	4.5	12.7	20.0	Yaskawa SGMAH-0XXN2XX, SGMAH-04XXN2XX NEMA 23 Face
N341-HD185	20.0	0.5	73.03	3.0	98.425	5.5	12.5	37.0	Parker HV/LV34
N342-HD185	15.0	0.5	73.03	3.0	98.425	5.5	12.7	30.0	Parker BE34



HD Series XY Adapter Dimensions

Dimensions (mm)

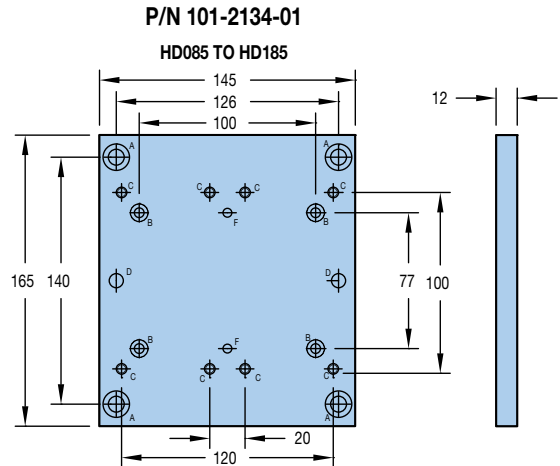
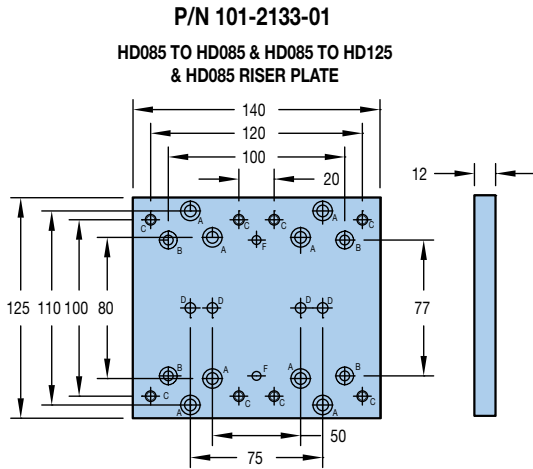

Screw Driven Tables

Hole	Description – mm in]	Qty
A	Ø 6.6 [0.256] Thru Hole with a counterbored Ø 11.0 [0.433] X 7.0 [0.276] deep hole	8
B	Ø 5.5 [0.217] Thru Hole with a counterbored Ø 10.0 [0.394] X 6.0 [0.236] Far Side	4
C	Drill & Tap Thru M6 X 1	8
D	Ø 6.006 ^{+0.006} / _{-0.000} [0.2365 ^{+0.0002} / _{-0.0000}]	4
F	Ø 5.006 ^{+0.006} / _{-0.000} [0.1971 ^{+0.0002} / _{-0.0000}]	2

Hole	Description – mm in]	Qty
A	Ø 9.0 [0.3541] Thru Hole with a counterbored Ø 15.0 [0.591] X 9.0 [0.354] deep hole	4
B	Ø 5.5 [0.217] Thru Hole with a counterbored Ø 10.0 [0.394] X 6.0 [0.236] Far Side	4
C	Drill & Tap Thru M6 X 1	8
D	Ø 8.006 ^{+0.006} / _{-0.000} [0.3150 ^{+0.0002} / _{-0.0000}]	4
F	Ø 5.006 ^{+0.006} / _{-0.000} [0.1971 ^{+0.0002} / _{-0.0000}]	2

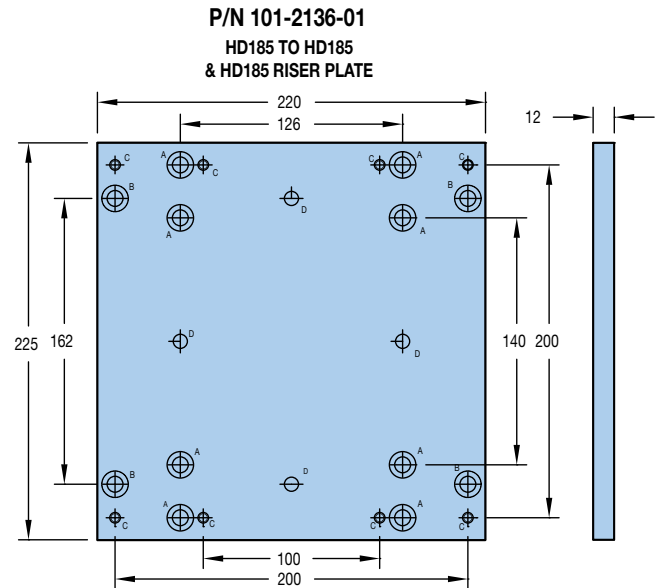
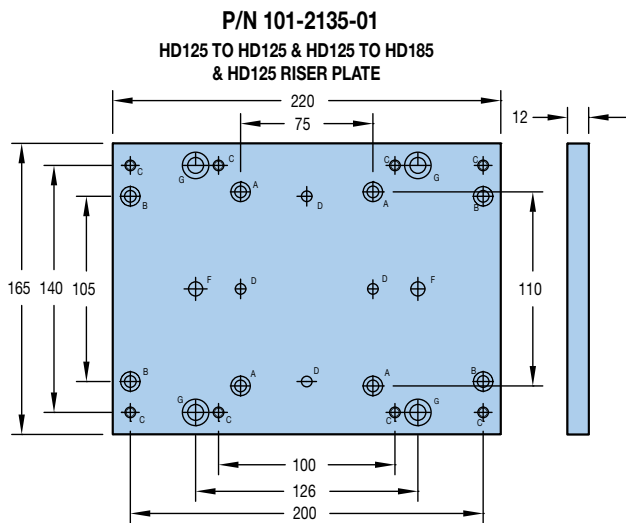

Hole	Description	Qty
A	Ø 6.6 [0.256] Thru Hole with a counterbored Ø 11.0 [0.433] X 7.0 [0.276] deep hole	4
B	Ø 6.6 [0.256] Thru Hole with a counterbored Ø 11.0 [0.433] X 7.0 [0.276] deep hole - Far Side	4
C	Drill & Tap Thru M6 X 1	8
D	Ø 6.006 ^{+0.006} / _{-0.000} [0.2365 ^{+0.0002} / _{-0.0000}]	4
F	Ø 8.006 ^{+0.006} / _{-0.000} [0.3150 ^{+0.0002} / _{-0.0000}]	2
G	Ø 9.0 [0.3541] Thru Hole with a counterbored Ø 15.0 [0.591] X 9.0 [0.354] deep hole	4

Hole	Description	Qty
A	Ø 9.0 [0.3541] Thru Hole with a counterbored Ø 15.0 [0.591] X 9.0 [0.354] deep hole	8
B	Ø 9.0 [0.3541] Thru Hole with a counterbored Ø 15.0 [0.591] X 9.0 [0.354] deep hole - Far Side	4
C	Drill & Tap Thru M6 X 1	8
D	Ø 8.006 ^{+0.006} / _{-0.000} [0.3150 ^{+0.0002} / _{-0.0000}]	4

HD015 Series Dimensions

Dimensions (mm)

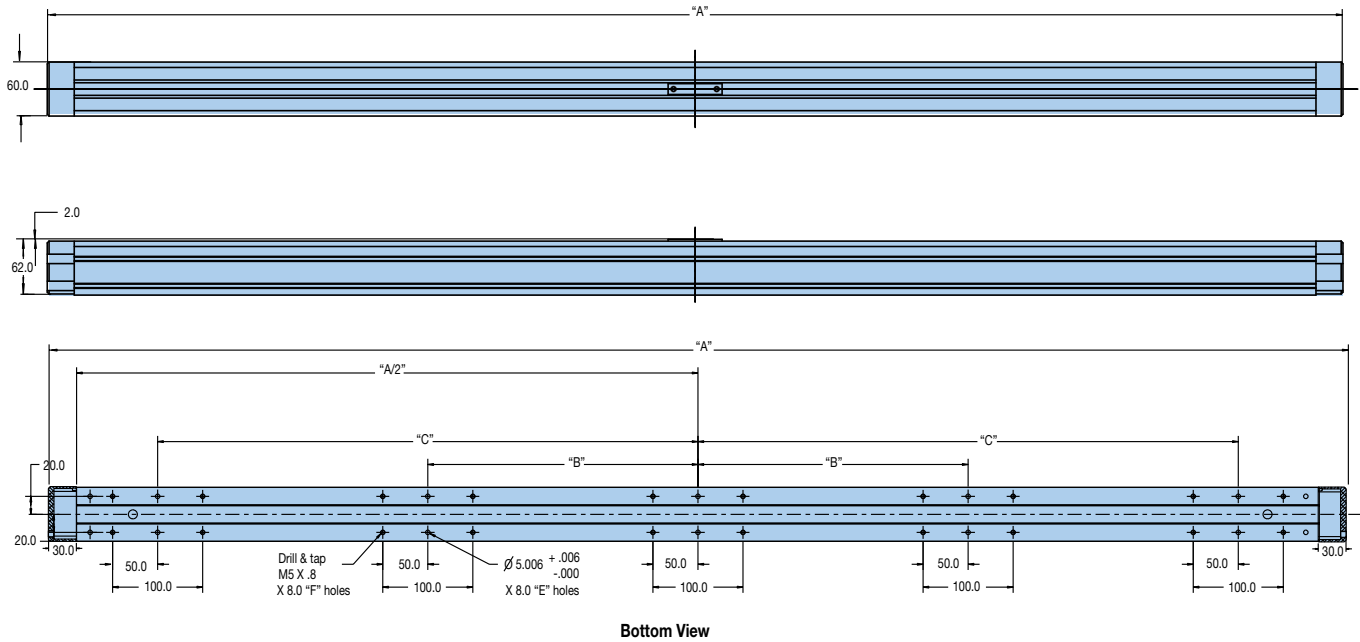

Model	Travel	Dimensions					
		A	B	C	D	E	F
HD015T01	100	340.0	-	-	5	2	4
HD015T02	200	440.0	-	-	6	2	4
HD015T03	300	540.0	-	150.0	8	6	12
HD015T04	400	640.0	-	200.0	10	6	12
HD015T05	500	740.0	-	250.0	11	6	12
HD015T06	600	840.0	-	300.0	13	6	12
HD015T07	700	940.0	-	345.0	15	6	12
HD015T08	800	1040.0	-	400.0	16	6	12
HD015T09	900	1140.0	-	450.0	18	6	12
HD015T10	1000	1240.0	-	500.0	20	6	12
HD015T11	1100	1340.0	-	550.0	21	6	12
HD015T12	1200	1440.0	300.0	600.0	23	10	20
HD015T13	1300	1540.0	325.0	650.0	25	10	20
HD015T14	1400	1640.0	350.0	700.0	26	10	20
HD015T15	1500	1740.0	375.0	750.0	28	10	20
HD015T16	1600	1840.0	400.0	800.0	30	10	20
HD015T17	1700	1940.0	425.0	850.0	32	10	20
HD015T18	1800	2040.0	450.0	900.0	33	10	20
HD015T19	1900	2140.0	475.0	950.0	35	10	20
HD015T20	2000	2240.0	500.0	100.0	36	10	20

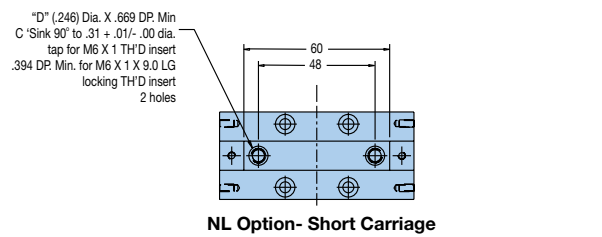
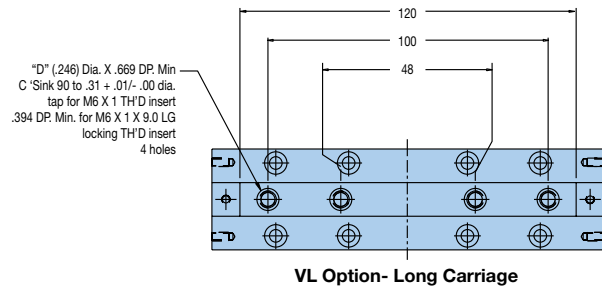



Fill in an order code from each of the numbered fields to create a complete model order code.

① ② ③ ④ ⑤ ⑥ ⑦ ⑧

Order Example: HD085 T08 S D02 M020 LH2 B1 R1

① Series

HD085 85 mm

② Travel*

T01 100 mm
T02 200 mm
T03 300 mm
T04 400 mm
T05 500 mm
T06 600 mm
T07 700 mm
T08 800 mm
T09 900 mm
T10 1000 mm
T11 1100 mm
T12 1200 mm

③ Grade

N Industrial Grade
S Standard Grade

④ Drive

D02* 5 mm lead
D03 10 mm lead
D04 20 mm lead

*Maximum travel for D02 (5 mm lead) = 800 mm (T08).

⑤ Motor Options*

F011 Yaskawa SGMAH-01, SGM-01
 Kollmorgen AKM1X-AN
 Allen Bradley Y-1002, Y-1003
F012 Yaskawa SGMAH-A1XXF4, SGMAH-A3XXF4X,
 SGM-03,SGM-A5
F021 Allen Bradley LD-2003
F031 Parker SMB60/HDY55
 Allen Bradley MPL1510/1520/1530
F041 Kollmorgen AKM2X-AN
 Indramat MKD025
F051 Yaskawa SGMP-01, SGMPH-01-XXXX
F061 Yaskawa SGMAH-02XXF4X, SGMAH-04XXF4X,
 SGM-02, SGM-04
 Allen Bradley Y-2006, Y-2012

F071 Parker J070/NO70/HDY70
 Allen Bradley MPL210/220/230
 Kollmorgen B102/BH-122
F072 Kollmorgen B104/B106, M-103/105/107,
 AKM3X-AN, BH-124/126
M010 Servo with standard encoder (SM232AE-TPSN),
 In-line
M011** Servo with standard encoder (SM232AE-TPSN),
 Parallel "A"
M012** Servo with standard encoder (SM232AE-TPSN),
 Parallel "B"
M020*** Servo with standard encoder (SM232AE-TPSB),
 In-line
M021*** Servo with standard encoder (SM232AE-TPSB),
 Parallel "A"
M022*** Servo with standard encoder (SM232AE-TPSB),
 Parallel "B"
M110 Servo with smart encoder (SM232AQ-TPSN),
 In-line
M100 Stepper (HV232-02-10), In-line only
M310 Servo motor mount and coupling only (SMB-F5-S9),
 inline
N231 Parker ES23X
 Allen Bradley N-2302, N-2304
 Animatics SM2310D, SM2320D
N232 Parker SM23X , BE23X
N233 Yaskawa SGMAH-0XXN2XX,
 SGMAH-04XXN2XX NEMA 23 Face
N341 Parker HV/LV34xx (motor sits above and below
 table)

*See page 101 for additional new "A" or "B" parallel motor codes.

** REQUIRES CUSTOM PART NO. CM232AE-115594

*** REQUIRES CUSTOM PART NO CM232AE-115638

⑥ Home/Limit Switch*

LH1 No sensors
LH2 NPN standard (NC limits, NO home)
LH3 PNP standard (NC limits, NO home)
LH4 PNP standard (NO limits, NO home)

*Includes 5 meter extension cables

⑦ Brake*

B1 No brake

*See motor options

⑧ Environmental Protection

R1 IP30, Maintenance free

Screw Driven
Tables

Fill in an order code from each of the numbered fields to create a complete model order code.

① ② ③ ④ ⑤ ⑥ ⑦ ⑧

Order Example: HD125 T04 S D02 M030 LH2 B1 R1

① **Series**

HD125 125 mm

② **Travel***

T02 200 mm
T03 300 mm
T04 400 mm
T05 500 mm
T06 600 mm
T08 800 mm
T10 1000 mm
T12 1200 mm
T14 1400 mm
T15 1500 mm

*Maximum travel for D02 (5 mm lead) = 800 mm (T08).
 Maximum travel for D03 (10 mm lead) = 1000 mm (T10)

③ **Grade**

N Industrial Grade
S Standard Grade

④ **Drive**

D02* 5 mm lead
D03 10 mm lead
D04 20 mm lead
D07** 40 mm lead

*D02 only with M01, M11 and M100 motors.
 **D07 option will lose 50 mm of travel below 1100 mm stroke units.

⑤ **Motor Options***

F021 Allen Bradley LD-2003
F031 Parker SMB60/HDY55
 Allen Bradley MPL1510/1520/1530
F041 Kollmorgen AKM2X-AN
 Indramat MKD025
F061 Yaskawa SGMAH-02XXF4X, SGMAH-04XXF4X,
 SGM-02, SGM-04
 Allen Bradley Y-2006, Y-2012
F062 Yaskawa SGMAH-02XXF4X, SGMAH-04XXF4X,
 SGM-02, SGM-04
 Allen Bradley Y-2006, Y-2012
F071 Parker J070/NO70/HDY70
 Allen Bradley MPL210/220/230
 Kollmorgen B102/BH-122
F072 Kollmorgen B104/B106, M-103/105/107,
 AKM3X-AN, BH-124/126
F081 Yaskawa SGMPH-02XXX,
 SGMPH-04XXX, SGMP-02, SGMP-04
F082 Yaskawa SGMAH-08 SGM-08
 Allen Bradley Y-3023
F091 Allen Bradley LD-3009
F101 Indramat MKD041

F111 Parker JO92X/NO92X
F121 Parker MPP92X
 Allen Bradley MPL310/320/330, LD-4012
F122 Kollmorgen AKM4X-AN Mounting Code
M010** Servo with standard encoder (SM232AE-TPSN),
 In-line
M011** Servo with standard encoder (SM232AE-TPSN),
 Parallel "A"
M012** Servo with standard encoder (SM232AE-TPSN),
 Parallel "B"
M030*** Servo with standard encoder (SM233AE-TPSN),
 In-line
M031*** Servo with standard encoder (SM233AE-TPSN),
 Parallel "A"
M032*** Servo with standard encoder (SM233AE-TPSN),
 Parallel "B"
M040 Servo with standard encoder (CMP0921B1E)
M100 Stepper (HV232-02-10)
M310 Servo motor mount and coupling only (SMB-
 F5-S11), inline
N231 Parker ES23X
 Allen Bradley N-2302, N-2304
 Animatics SM2310D, SM2320D
N232 Parker SM23X , BE23X
N233 Yaskawa SGMAH-0XXN2XX,
 SGMAH-04XXN2XX NEMA 23 Face
N341 Parker HV/LV34
N342 Parker BE34

*See page 105 for additional new "A" or "B" parallel motor codes.

**REQUIRES CUSTOM PART NO. CM232AE-115594

***REQUIRES CUSTOM PART NO CM232AE-115596

⑥ **Home/Limit Switch***

LH1 No sensors
LH2 NPN standard (NC limits, NO home)
LH3 PNP standard (NC limits, NO home)
LH4 PNP standard (NO limits, NO home)

*Includes 5 meter extension cables

⑦ **Brake***

B1 No brake
B2 Brake

⑧ **Environmental Protection**

R1 IP30, Maintenance free



Fill in an order code from each of the numbered fields to create a complete model order code.

① ② ③ ④ ⑤ ⑥ ⑦ ⑧

Order Example: HD185 T05 S D02 M030 LH2 B1 R1

① **Series**

HD185 185 mm

② **Travel***

T03 300 mm
T04 400 mm
T05 500 mm
T06 600 mm
T08 800 mm
T10 1000 mm
T12 1200 mm
T14 1400 mm
T16 1600 mm
T18 1800 mm
T20 2000 mm

③ **Grade**

N Industrial Grade
S Standard Grade

④ **Drive**

D02** 5 mm lead
D03 10 mm lead
D04 20 mm lead
D07 40 mm lead

*Maximum travel for D02 (5 mm lead) = 800 mm (T08).
 Maximum travel for D03 (10 mm lead) = 1000 mm (T10)
 **D02 only with M01 and M11 motors.

⑤ **Motor Options***

F021 Allen Bradley LD-2003
F031 Parker SMB60/HDY55
 Allen Bradley MPL1510/1520/1530
F041 Kollmorgen AKM2X-AN
 Indramat MKD025
F061 Yaskawa SGMAH-02XXF4X, SGMAH-04XXF4X,
 SGM-02, SGM-04
 Allen Bradley Y-2006, Y-2012
F062 Yaskawa SGMAH-02XXF4X, SGMAH-04XXF4X,
 SGM-02, SGM-04
 Allen Bradley Y-2006, Y-2012
F071 Parker J070/NO70/HDY70
 Allen Bradley MPL210/220/230
 Kollmorgen B102/BH-122
F072 Kollmorgen B104/B106, M-103/105/107,
 AKM3X-AN, BH-124/126
F081 Yaskawa SGMPH-02XXX,
 SGMPH-04XXX, SGMP-02, SGMP-04
F082 Yaskawa SGMAH-08 SGM-08
 Allen Bradley Y-3023
F083 Allen Bradley LD-3009
F101 Indramat MKD041
F111 Parker JO92X/NO92X

F121 Parker MPP92X
 Allen Bradley MPL310/320/330, LD-4012
F122 Kollmorgen AKM4X-AN Mounting Code
M010** Servo with standard encoder (SM232AE-TPSN), In-line
M011** Servo with standard encoder (SM232AE-TPSN),
 Parallel "A"
M012** Servo with standard encoder (SM232AE-TPSN),
 Parallel "B"
M030*** Servo with standard encoder (SM233AE-TPSN), In-line
M031*** Servo with standard encoder (SM233AE-TPSN),
 Parallel "A"
M032*** Servo with standard encoder (SM233AE-TPSN),
 Parallel "B"
M040 Servo with standard encoder (CMP0921B1E), In-line
M041 Servo with standard encoder (CMP0921B1E),
 Parallel "A"
M042 Servo with standard encoder (CMP0921B1E),
 Parallel "B"
M141 Servo (CMP0921B3E), Parallel "A"
M142 Servo (CMP0921B3E), Parallel "B"
N231 Parker ES23X
 Allen Bradley N-2302, N-2304
 Animatics SM2310D, SM2320D
N232 Parker SM23X, BE23X
N233 Yaskawa SGMAH-0XXN2XX,
 SGMAH-04XXN2XX NEMA 23 Face
N341 Parker HV/LV34
N342 Parker BE34

*See page 109 for additional new "A" or "B" parallel motor codes.

**REQUIRES CUSTOM PART NO. CM232AE-115594

***REQUIRES CUSTOM PART NO. CM232AE-115596

⑥ **Home/Limit Switch***

LH1 No sensors
LH2 NPN standard (NC limits, NO home)
LH3 PNP standard (NC limits, NO home)
LH4 PNP standard (NO limits, NO home)

*Includes 5 meter extension cables

⑦ **Brake***

B1 No brake
B2 Brake

⑧ **Environmental Protection**

R1 IP30, Maintenance free

Screw Driven
Tables

Fill in an order code from each of the numbered fields to create a complete model order code.

① ② ③ ④

Order Example: HD015 T04 NL R1

① **Series**

HD015 15 mm

② **Travel***

T03 300 mm

T04 400 mm

T05 500 mm

T06 600 mm

T08 800 mm

T10 1000 mm

T12 1200 mm

T14 1400 mm

T16 1600 mm

T18 1800 mm

T20 2000 mm

③ **Carriage Option**

NL Single bearing truck

VL Double bearing truck

④ **Environmental Protection**

R1 IP30, Maintenance free