

Chelsea® 524 Series

Two Gear Mechanically Shifted
Rear Mount PTO



Overview:

The two gear design rear mount PTO provides a compact housing which helps eliminate clearance issues along with three speed ratios to meet your application requirements. High capacity bearings and robust gear designs provide torque ratings up to 300 lbs-ft [407 Nm] for the ultimate performance. The superior design of this PTO provides all the power you will need. There is no need to derate the PTO for continuous duty applications. The 524 is designed to fit on many popular transmissions and features six shift options integrated into the PTO system for a space saving design. The two direct mount pump flanges and the 1410 Flange options provide increased extended PTO and pump shaft versatility. Power, ease of maintenance and installation make the 524 Series a great choice for your vocational truck requirements.

- Aerial
- Fire
- Tippers
- Refuse
- Sewer & Sanitation

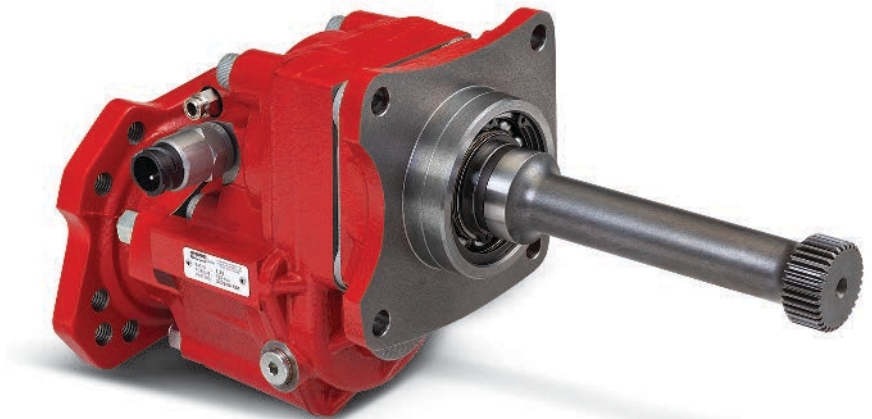

Contact Information:

Parker Hannifin Corporation
Chelsea Products Division
8225 Hacks Cross Road
Olive Branch, MS 38654 USA

Phone: 1-888-PH4-TRUK
(1-888-744-8785)

Fax: 1-662-895-1069
chelseacustserv@parker.com

www.parker.com/chelsea

Product Features and Benefits:

- **Torque** - Continuous torque rating up to 300 lbs-ft [407 Nm].
- **Rear Mount Design** - Requires less mounting space and simplifies installation.
- **Backlash** - None to set - simplifying installation.
- **Connection** - Sealed bayonet connector for Indicator Switch.
- **Pump Flange** - Two (2) Direct mount pump options. 1410 Flange for Driveline.
- **Shift Options** - Six (6) shift options.



ENGINEERING YOUR SUCCESS.

524 SERIES POWER TAKE-OFF SPECIFICATIONS AND TECHNICAL DATA

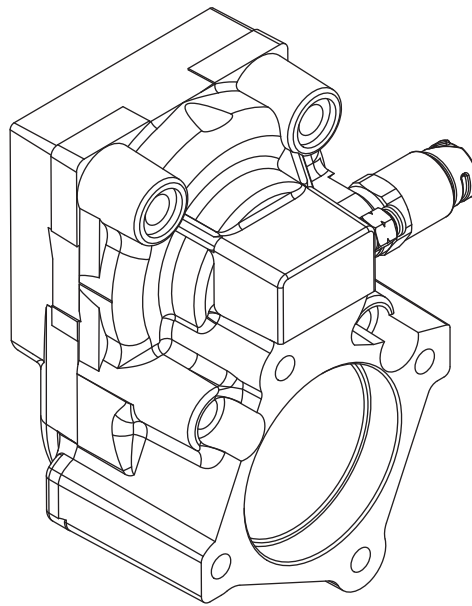
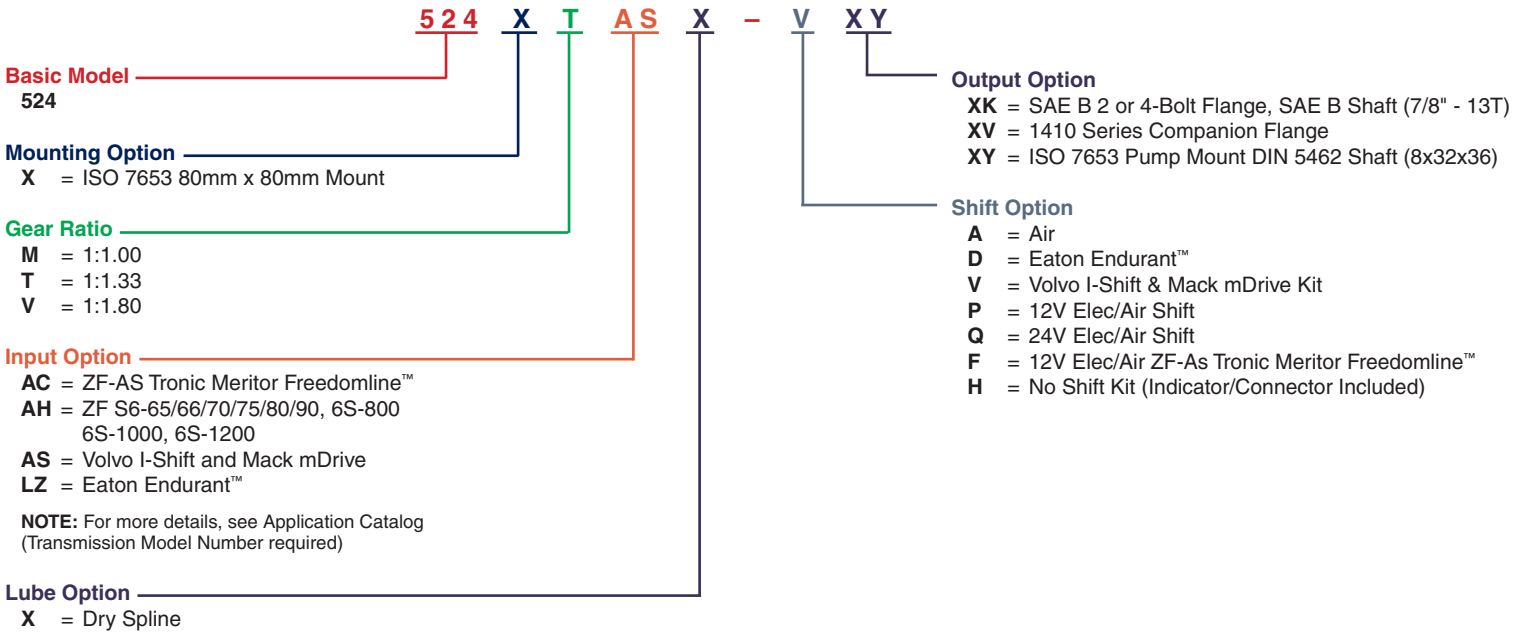

Specifications Chart	Approximate Weight: 22.3 lbs. [10.1 kg]		
	524*M	524*T	524*V
Intermittent & Continuous Torque Rating (lbs-ft) [Nm]	300 [407]	300 [407]	258 [350]
HP Rating for Intermittent & Continuous Duty			
At 500 RPM of Output Shaft (HP) [Kw]	29 [22]	29 [22]	25 [18]
At 1000 RPM of Output Shaft (HP) [Kw]	57 [43]	57 [43]	49 [37]