

Type SC1,SC2



November 2001
Installation Information

Solenoid Valve

TYPE SC1,SC2

Port Size 3/8"-2-5/8" (9-66mm)

Compact, wide range, solder mount solenoid valve for service with most refrigerants and their corresponding lubricants. Requires R/S commercial coils offered with 18 in. leads or DIN connector.

Purpose

A solenoid valve is an electrically operated device used to control the flow of liquids or gases in a fully open or fully closed configuration. Solenoid valves do not modulate; they either permit or prevent fluid flow in the normal direction.

Principles of Operation

The **SC1, and SC2**, are normally closed pilot operated solenoid valves that employ the Refrigerating Specialties Commercial operator and the corresponding selection of R/S commercial coils. Starting from the closed position, the plunger needle is seated in the pilot port preventing pilot stream flow. Energization of the solenoid coil forms a magnetic field, drawing the plunger upward lifting it off its seat. This permits pilot stream flow through the seat. De-energization of the solenoid coil breaks the magnetic field and permits the spring-assisted plunger to return to seat, interrupting the pilot stream

S81, S82

When energized, fluid flow through the pilot port forces the piston downward and pushes the main port plug open, thereby permitting flow of the refrigerant through the valve. The closing spring meanwhile is held in a compressed position. When de-energized, fluid flow through the pilot port is stopped. Bleed-off through the bleed hole in the piston decreases the pressure above the piston and allows the closing spring to force the main port plug upward into a close position to stop the flow. The pressure difference across the valve, acting upon the area of the valve seat, plus the force of the closing spring, holds the main port plug in a tightly closed position.

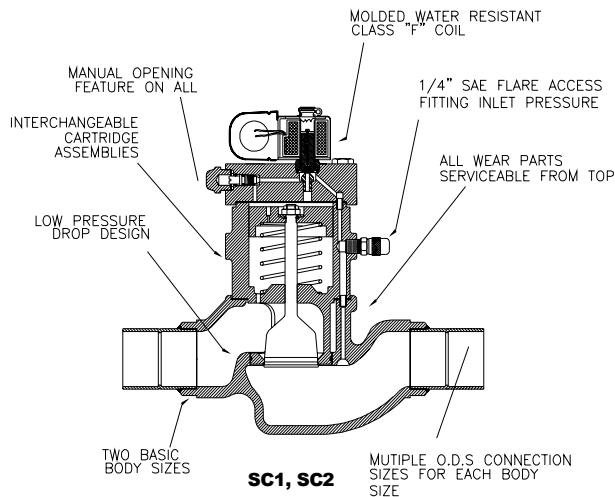

Fig. 1

Installation

Refer also to Safety Installation Bulletin RSBCV. Do not remove the protective covers from the inlet and outlet of the valve until ready to install. They protect the interior from dirt and other foreign matter.

Select a location for installation where the valve will be easily accessible for adjustment and maintenance. Avoid locations where personnel, traffic, material handling or other equipment may damage the valve. If the valve surfaces will be cold, avoid areas where ice may accumulate in the body.

Before installing the valve, check to see that all chips, scale, dirt and other foreign material are removed from the pipes; also be sure the arrow on the valve body is pointing in the flow direction. Remove the protective covers from the valve.

Valves with Commercial operators (SV, S81, and S82, SC) can be mounted in a horizontal or vertical line.

In a liquid line the Solenoid Valve should be near the expansion valve inlet. It is advisable to install the RSF strainer ahead of the valve for protection against dirt and chips.

Install with the arrow on the valve body in the direction of flow. If the valve is backwards, the flow will not be

stopped when the valve is electrically de-energized. Solenoid Valves can stop flow only in the direction from normal inlet to normal outlet (as shown by the arrow on the body). If reversal of pressure occurs in the system so the outlet pressure exceeds the inlet pressure the main valve plug will be blown away from its seat and reverse flow will occur. If a system has this type of pressure reversal (as encountered during hot gas defrost with liquid recirculation systems), a check valve such as Refrigerating Specialties Division Type CK4A will need to be added. Check valves must be installed downstream to avoid trapping liquid.

If the valve is to be insulated be sure to allow access to the manual opening stem and strainer cover.

Do not insulate the coil or coil housing.

Connect the solenoid lead wires only to an electrical supply source as indicated on the solenoid coil. The power source must be capable of supplying full, constant voltage. The wires to which the solenoid leads are connected must be of suitable gauge, and must be insulated and enclosed appropriate to the voltage and the environmental or conformity requirements.

For parts selection see Bulletin 33-00, latest edition.
For solenoid coil availability see RSBCV latest edition.

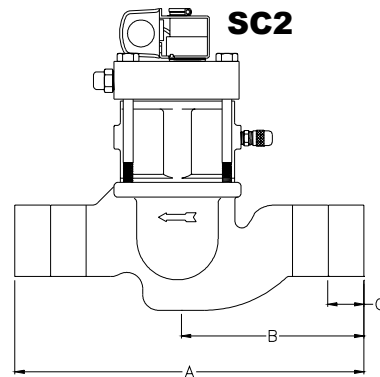
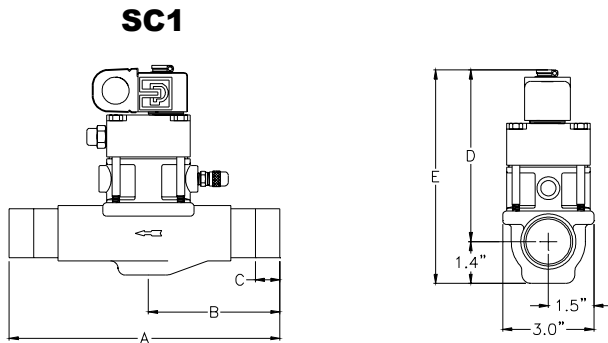

Type		SC1					SC2		
Connection Size		7/8" 22mm	1-1/8" 28mm	1-3/8" 35mm	1-5/8" 42mm	2-1/8" 54mm	1-5/8" 42mm	2-1/8" 54mm	2-5/8" 66mm
A	inch	9.6	9.6	9.4	9.9	11.1	11	12	13.5
	mm	244	244	239	251	282	279	305	343
B	inch	4.8	4.8	4.7	5	5.6	5.9	6.4	7.1
	mm	122	122	119	127	142	149	182	181
C	inch	0.8	0.9	1	1.1	1.2	1.1	1.4	1.7
	mm	20	23	25	28	30	38	36	44
D	inch	5.5	5.5	5.5	5.5	5.5	7.2	7.2	7.2
	mm	140	140	140	140	140	183	183	183
E	inch	6.9	6.9	6.9	6.9	6.9	9.4	9.4	9.4
	mm	175	175	175	175	175	239	239	239

