

GreenMAX 6600 Series

Installation and Service Instructions

- Read all instructions before beginning installation. Improper installation could cause personal injury or property damage.
- Mounting fasteners and inlet/outlet port fittings not included.

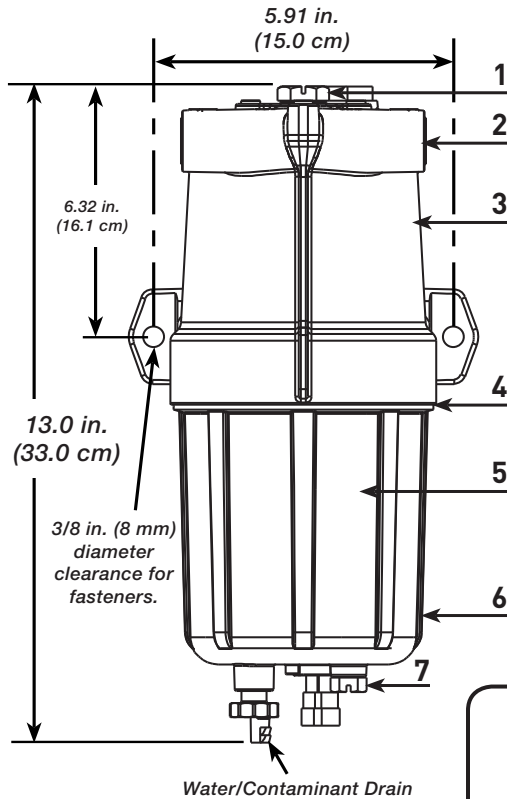

Specifications:

- Fuel Ports: 7/8"-14 UNF (SAE J1926)
- Return Fuel Heat Fittings: 8 SAE 45° Flare (3/4"-16)
- Max. Flow Rate: 150 GPH (568 LPH)
- Clean Pressure Drop (@150 GPH): 0.4 PSI (0.03 bar)
- Max. Allowable Pressure: 30 PSI (2.07 bar)
- Bowl Capacity: 10.1 oz (300 ml)
- Particulate Removal Efficiency (SAE J1985): greater than 95%
- Water Removal Efficiency (SAE J1839): min. 95%
- Ambient Temp. Range: -22° to +212°F (-30° to +100°C), Max. Fuel Temp: 158°F (70°C)
- Suction-side installations only
- Fuel compatibility: diesel fuel per ASTM D975 and biodiesel blends up to B20 per ASTM D7467
- Do not use on gasoline applications
- Properties of biodiesel vary greatly and can have an impact on water separation performance

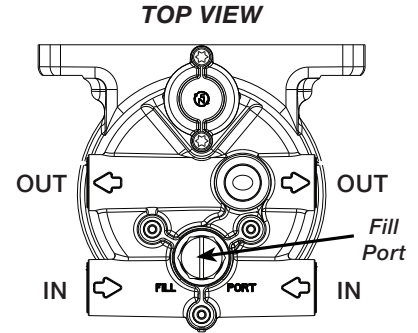

Plug any unused fuel ports.

Replacement Parts

1. RK22100 - Fill Port Plug Kit
2. RK61713 - Plug Kit
3. N/A - Housing/Head Assembly Kit (no service kit available)
4. N/A - Bowl O-ring Kit (included with replacement filter)
5. Replacement Filters (includes bowl O-ring)
R61691S (2 micron),
R61691T (10 micron),
R61691P (30 micron)
6. RK6166301 - Clear Bowl Kit, no heater
RK6166312 - Clear Bowl Kit, 12vdc heater
RK6166324 - Clear Bowl Kit, 24vdc heater
7. RK2012601 - Plug Kit
8. PFRK61730 - Bowl Wrench (not shown)
9. RK6165804 - Return Fuel Heat (not shown)
10. RK 30876 - Heater Harness (shown on page 2)

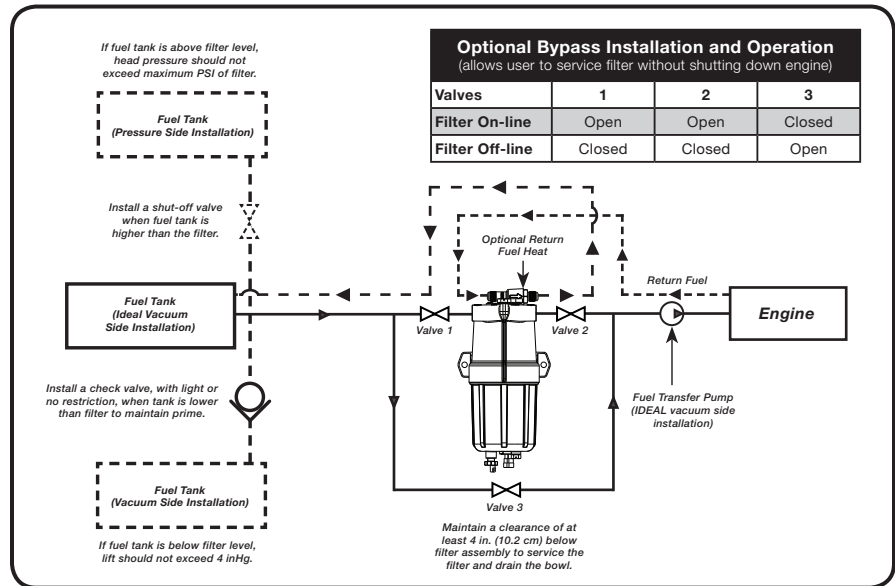

All products manufactured or distributed by Racor are subject to the following, and only the following, LIMITED EXPRESS WARRANTIES, and no others: For a period of one (1) year from and after the date of purchase of a new Racor product, Racor warrants and guarantees only to the original purchaser-user that such a product shall be free from defects of materials and workmanship in the manufacturing process. The warranty period for pumps and motors is specifically limited to ninety (90) days from date of purchase. A product claimed to be defective must be returned to the place of purchase. Racor, at its sole option, shall replace the defective product with a comparable new product or repair the defective product. This express warranty shall be inapplicable to any product not properly installed and properly used by the purchaser-user or to any product damaged or impaired by external forces.

THIS IS THE EXTENT OF WARRANTIES AVAILABLE ON THIS PRODUCT. RACOR SHALL HAVE NO LIABILITY WHATSOEVER FOR CONSEQUENTIAL DAMAGES FLOWING FROM THE USE OF ANY DEFECTIVE PRODUCT OR BY REASON OF THE FAILURE OF ANY PRODUCT. RACOR SPECIFICALLY DISCLAIMS ALL OTHER WARRANTIES, EXPRESS OR IMPLIED INCLUDING, WITHOUT LIMITATION, ALL WARRANTIES OF FITNESS FOR A PARTICULAR PURPOSE (EXCEPT FOR THOSE WHICH APPLY TO PRODUCT OR PART THEREOF THAT IS USED OR BOUGHT FOR USE PRIMARILY FOR PERSONAL, FAMILY, OR HOUSEHOLD PURPOSES), WARRANTIES OF DESCRIPTION, WARRANTIES OF MERCHANTABILITY, TRADE USAGE OR WARRANTIES OR TRADE USAGE.

Warning! Failure or improper selection or improper use of the products and/or systems described herein or related items can cause death, personal injury and property damage. This document and other information from Parker Hannifin Corporation, its subsidiaries and authorized distributors provide product and/or system options for further investigation by users having technical expertise. It is important that you analyze all aspects of your application and review the information concerning the product or system in the current product catalog. Due to the variety of operating conditions and applications for these products or systems, the user, through its own analysis and testing, is solely responsible for making the final selection of the products and systems and assuring that all performance, safety and warning requirements of the applications are met. The products described herein, including with limitation, product features, specifications, designs, availability and pricing, are subject to change by Parker Hannifin Corporation and its subsidiaries at any time without notice.

The following statement is required pursuant to proposition 65, applicable in the State of California: 'This product may contain a chemical known to the State of California to cause cancer or reproductive toxicity'.



Installation Guidelines

Refer to Mounting/Installation Diagrams on page one and install as follows (new install):

1. Engine must be off and cool to touch.
2. Apply motor oil to o-rings on UNF/SAE inlet/outlet fittings.
3. Thread fittings into appropriate fuel ports and tighten snugly. Plug unused ports (if any) with port plugs and tighten snugly.
4. Mount filter vertically in a protected area away from flying debris and heat sources. Maintain at least 4.0" (10.2 cm) of clearance below filter for draining water and servicing filter.
5. Attach fuel lines to filter port fittings. Avoid tight bends and rubbing areas when routing hose.
6. Connect water probe and heater wires, if equipped.
7. Proceed to 'Priming' section.

Priming

1. Use a 7/8" open-end wrench to remove fill port plug on top of assembly. Prime filter by filling assembly with fuel.
2. Thread fill port plug back into port and tighten snugly.
3. Verify all other connections are tight.
4. Start engine and check for leaks. Correct as necessary with engine off.

Service

Filter replacement frequency is determined by contamination level in fuels. Fuel flow to engine becomes restricted as filter gradually plugs with contaminants, resulting in noticeable power loss and/or hard starting. As a guideline, change filter every 500 hours, 10,000 miles, every other oil change, annually, or at first indication of power loss, whichever occurs first. **Always carry extra replacement filters as one tankful of excessively dirty fuel can quickly plug a filter.**

1. Engine must be off and cool to touch.
2. Close all fuel valves, if applicable, to make sure excess fuel does not spill during servicing.
3. Disconnect water probe and heater

- connectors, if equipped.
4. Open fill port plug on mounting head.
5. Drain unit of fuel, into a suitable container, by turning drain on bottom of bowl.
6. Remove bowl and filter. Dispose of filter properly. Bowl is reusable.
7. Lubricate new filter seals with motor oil or clean fuel and install with new filter.
8. Re-install bowl and tighten snugly by hand or using a bowl wrench.
9. Connect water probe and heater connectors, if equipped.
10. Open all fuel valves, if applicable.
11. Proceed to 'Priming' section.

Draining the Bowl

Water is heavier than fuel and will settle to bottom of the bowl and appear different in color if collected in a clear jar. In high humidity environments, check bowl frequently—daily if a poor fuel source is suspected. *Contact your local Racor distributor for water-in-fuel sensor options.*

1. Make sure engine is off and cool to touch.
2. Open fill port plug using a 7/8" wrench.
3. Drain water from filter by opening self-venting drain. Close as soon as all water has evacuated.

If drain is open too long, the entire filter may drain completely of water and fuel.

4. Follow 'Priming' section.

Troubleshooting

If filter fails to hold prime, first check vent plug, drain valve, fittings, head, filter, and bowl are properly tightened. Next, check fuel line connections and verify they are free of pinches or unnecessary bends and check to see if fuel tank strainer (or pick-up tube) is clogged. If problems persist and filter is new, call Technical Support at 800-344-3286, 7 AM to 4 PM, Pacific Time.

In-Bowl Heater

Warning! Do not active bowl heater unless the module is primed with fuel.

Note: Electric heaters must not be used in gasoline applications.

The in-bowl heater is a cold weather starting aid with an internal automatic thermostat that turns the heater on if fuel temperature drops below 45°F (7°C). Heat is supplied just below the filter to melt wax crystals and allow fuel to efficiently pass through. The heater will automatically turn off at about 75°F (24°C). The heater is available in 12 vdc (200 watt) or 24 vdc (200 watt). The heater is operated by turning on the ignition switch for a minimum of 5 minutes prior to starting the engine.

Customer Supplied Items

1. Due to heater power demand, 16.2 amps for 12 vdc and 8 amps for 24 vdc, an additional relay is recommended for safest method of installation. Racor offers two relay kits (sold separately), RK 11861 for 12 vdc systems or RK 11862 for 24 vdc systems. These kits include an in-line fuse holder (and fuse).
2. An on-off toggle switch may be used to control power to heater relay. This allows the operator to cut power to heater relay during summer or when servicing the filter in cold environments.
3. All wires should be 14 AWG (American Wire Gauge), minimum.

Installation

1. Pin/Wire 1 must be used for Ground (-), Pin/Wire 2 must be used for Hot (+). See RK 30876 illustration below.
2. Wire/terminal connections should be soldered and crimped.
3. Run wires in protected locations. Avoid hot surfaces and places that could pinch or rub on the wires.

