



aerospace
climate control
electromechanical
filtration
fluid & gas handling
hydraulics
pneumatics
process control
sealing & shielding



VB Hydraulic Clamp

Catalogue PDE2636TCUK May 2012



ENGINEERING YOUR SUCCESS.



Important !

Before carrying out any service work, ensure that the valve and manifold have been vented. Remove the primary supply air hose to ensure total disconnection of the air supply before dismantling valves or blank connection blocks.



NB !

All technical data in this catalogue is typical only. The air quality is decisive for the valve life: see ISO 8573.



WARNING

FAILURE OR IMPROPER SELECTION OR IMPROPER USE OF THE PRODUCTS AND/OR SYSTEMS DESCRIBED HEREIN OR RELATED ITEMS CAN CAUSE DEATH, PERSONAL INJURY AND PROPERTY DAMAGE.

This document and other information from Parker Hannifin Corporation, its subsidiaries and authorized distributors provide product and/or system options for further investigation by users having technical expertise. It is important that you analyze all aspects of your application and review the information concerning the product or system in the current product catalog. Due to the variety of operating conditions and applications for these products or systems, the user, through its own analysis and testing, is solely responsible for making the final selection of the products and systems and assuring that all performance, safety and warning requirements of the application are met. The products described herein, including without limitation, product features, specifications, designs, availability and pricing, are subject to change by Parker Hannifin Corporation and its subsidiaries at any time without notice.

SALE CONDITIONS

The items described in this document are available for sale by Parker Hannifin Corporation, its subsidiaries or its authorized distributors. Any sale contract entered into by Parker will be governed by the provisions stated in Parker's standard terms and conditions of sale (copy available upon request).

VB Hydraulic Clamp

Clamp cylinders are single acting pneumatic cylinders with built-in oleo-pneumatic intensifiers. They can be used to solve most clamping, tightening etc problems.

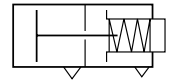

- Compact size for large forces (up to 2100 daN depending on the model and air pressure).
- Operated using a compressed air supply (no special installation required)
- Easy adjustment thanks to a fully threaded body
- Simple and rapid installation.



Clamping examples

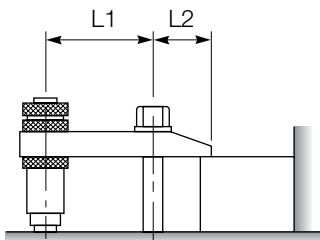

Clamping with intensified force
 $L1/L2 < 2$

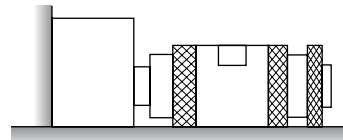

Horizontal clamping

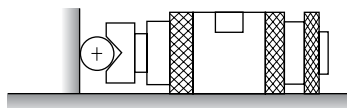

Clamping of cylindrical component using V groove clamp end

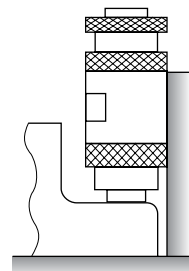

Vertical clamping

VB Hydraulic Clamp**Ordering references**

Order code	Max stroke (mm)	Ø external	Weight - g (lbs)
VB363C	3	36	570 (1.3)
VB366C	6	36	640 (1.4)
VB369C	9	36	890 (2.0)
VB483C	3	48	1050 (2.3)
VB486C	6	48	1350 (3.0)
VB489C	9	48	1152 (2.5)
VB4812C	12	48	1840 (4.0)
VBH483C	3	48	1240 (2.7)
VB606C	6	60	2360 (5.2)
VB609C	9	60	3120 (6.9)
VB6012C	12	60	3810 (8.4)
VBH603C	3	60	2360 (5.2)
VBH606C	6	60	3700 (8.1)

Mounting accessories

Mounting block

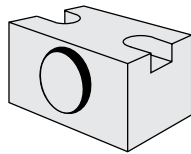

Rounded clamp piston end

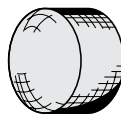

V groove clamp piston end

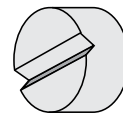

Mounting for VB	Mounting block	Rounded end	V groove end
Ø 36	FVA36-1	BVA36-16	BVA36-17
Ø 48	FVA48-1	BVA48-16	BVA48-17
Ø 60	FVA60-1	BVA60-16	BVA60-17
Seal kit for	VB Ø 36	VBH Ø 48	VB Ø 60
Order code	JJVB36	JJVBH48	JJVB60

Oil container suitable for all types of cylinder (250 ml capacity)

Model No.: **BH680VB**

Technical data**Material specification**

Body	Nickel plated steel
Piston rod	Hardened steel
Locking rings	Zinc plated steel
End cap	Zinc plated steel
Seals	Nitrile

Operation

Temperature range	+5°C to +50°C (41°F to 122°F)
Storage temperature	-20°C to +60°C (-4°F to 140°F)
Pressure range	1 to 9 bar (15 to 130 psi) (except VBH603 and VBH606 : 7 bar (101psi max.))
Air condition	Filtered air 40µ lubricated or non lubricated

Maintenance

For all operations see our maintenance instructions
All safety requirements must be observed.

VB Hydraulic Clamp

Technical data

Cylinder force

Note: The clamping time is given from the moment the clamp cylinder is pressurised to the time at when 90% of the clamping force is obtained, the cylinder completing a full stroke.

The release time is given from the moment the clamp cylinder starts to exhaust until the rod is fully retracted.

When the cylinder remains pressurised for more than 10 min. add 0,20 sec. to the release time.

These average times are given for information only. They will vary depending on the application and the cylinder inlet and exhaust circuits.

Order code	Max. stroke (mm)	Force at 6 bar daN (lbs)	Clamping time (s)	Release time (s)
VB363C	3	240 (540)	0,10	1,00
VB366C	6	240 (540)	0,15	1,30
VB369C	9	240 (540)	0,20	1,50
VB483C	3	530 (1190)	0,30	1,30
VB486C	6	530 (1190)	0,40	1,60
VB489C	9	530 (1190)	0,50	1,90
VB4812C	12	530 (1190)	0,60	2,20
VBH483C	3	1060 (2380)	0,50	0,70
VB606C	6	1140 (2560)	0,50	1,90
VB609C	9	1140 (2560)	0,60	2,30
VB6012C	12	1140 (2560)	0,70	2,50
VBH603C	3	1800 (4000)	0,50	0,70
VBH606C	6	1800 (4000)	0,60	1,05

Principle of operation

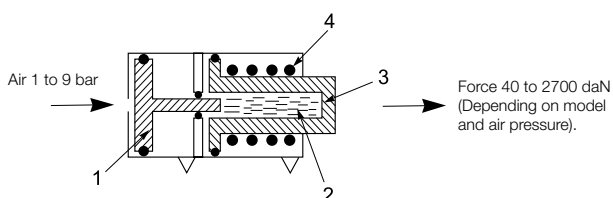

Air pressure applied to the pneumatic piston (1) causes the plunger to displace the enclosed oil in the hydraulic section of the cylinder (2). A high-pressure stroke results at the hydraulic piston (3) due to the differential areas of the two pistons.

The return of pistons (1) and (3) is caused by a return spring (4) when the air pressure is removed.

VB Hydraulic Clamp

Technical data

Working conditions

Clamp cylinders must be installed so that the force is directed along the axis. (Take care that the exhaust ports are not blocked and that they are protected from swarf, cutting oil, dust, etc.)

Do not operate the cylinder at no-load. The clamp cylinder must always be operated in conjunction with a clamping fixture (clamp or block) to limit the stroke to within the maximum length specified in the ordering reference table.

We recommend an effective stroke equal to the max. length minus 1mm.

Please contact us for applications requiring force during part of the stroke (marking, crimping, punching, etc.) and high speeds.

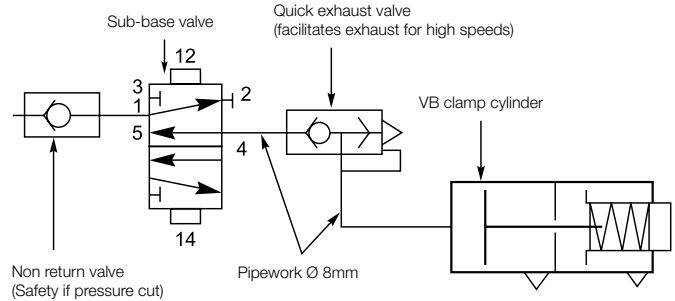

Pneumatic Circuit

For correct use of clamp cylinders, we recommend applications of the circuit diagram opposite:

Dimensions (mm)

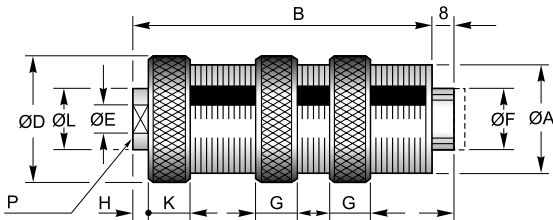

Order code	ØA	B	ØD	ØE	ØF	G	H	K	ØL	P
VB363C	M36 x 1,5	98,0	42	G1/8	22	12	4	13	22	17
VB366C	M36 x 1,5	127,5	42	G1/8	22	12	4	13	22	17
VB369C	M36 x 1,5	185,0	42	G1/8	22	12	4	13	22	17
VB483C	M48 x 1,5	111,0	56	G1/8	32	12	4	13	22	17
VBH483C	M48 x 1,5	148,0	56	G1/8	32	12	4	13	22	17
VB486C	M48 x 1,5	148,0	56	G1/8	32	12	4	13	22	17
VB489C	M48 x 1,5	188,0	56	G1/8	32	12	4	13	22	17
VB4812C	M48 x 1,5	234,0	56	G1/8	32	12	4	13	22	17
VBH603C	M60 x 2	175,0	70	G1/4	40	14	5	17	25	22
VB606C	M60 x 2	175,0	70	G1/4	40	14	5	17	25	22
VBH606C	M60 x 2	290,0	70	G1/4	40	14	5	17	25	22
VB609C	M60 x 2	249,0	70	G1/4	40	14	5	17	25	22
VB6012C	M60 x 2	314,0	70	G1/4	40	14	5	17	25	22

VB Hydraulic Clamp

Dimensions (mm)

Mounting accessories

Mounting block

For VB	Order code	A	B	C	ØD	E	F	G	P	R	ØV
Ø 36	FVA36-1	24,0	38,0	50,0	36,2	54,0	18,0	-	40,0	70,0	11,0
Ø 48	FVA48-1	30,0	47,0	60,0	48,2	70,0	20,0	-	50,0	90,0	13,5
Ø 60	FVA60-1	36,0	57,0	70,0	60,2	90,0	20,0	36,0	60,0	110,0	13,5

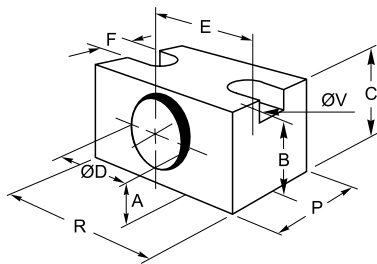

FVA 36 1
FVA 48 1

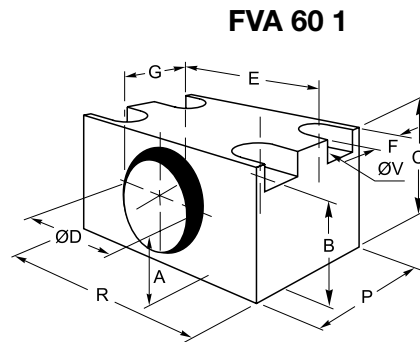

FVA 60 1

Rounded clamp piston end

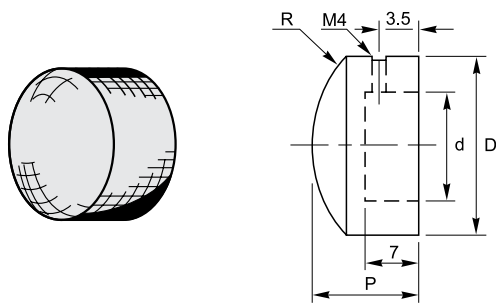

Dimensions (mm)

For VB	Order code	d	R	P	D
Ø 36	BVA36-16	22	25	15	30
Ø 48	BVA48-16	32	40	15	40
Ø 60	BVA60-16	40	50	18	50

V groove clamp piston end

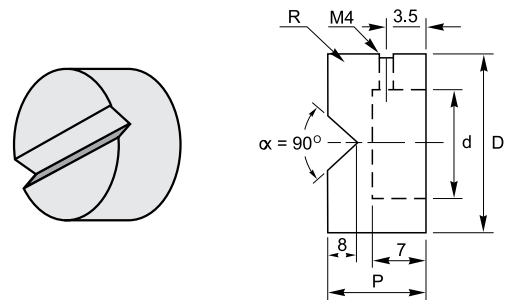

Dimensions (mm)

For VB	Order code	d	e	P	D
Ø 36	BVA36-17	22	5	15	30
Ø 48	BVA48-17	32	5	15	40
Ø 60	BVA60-17	40	8	18	50

Parker Worldwide

Europe, Middle East, Africa

AE – United Arab Emirates, Dubai

Tel: +971 4 8127100
parker.me@parker.com

AT – Austria, Wiener Neustadt

Tel: +43 (0)2622 23501-0
parker.austria@parker.com

AT – Eastern Europe, Wiener Neustadt

Tel: +43 (0)2622 23501 900
parker.easteurope@parker.com

AZ – Azerbaijan, Baku

Tel: +994 50 2233 458
parker.azerbaijan@parker.com

BE/LU – Belgium, Nivelles

Tel: +32 (0)67 280 900
parker.belgium@parker.com

BY – Belarus, Minsk

Tel: +375 17 209 9399
parker.belarus@parker.com

CH – Switzerland, Etoy

Tel: +41 (0)21 821 87 00
parker.switzerland@parker.com

CZ – Czech Republic, Klecany

Tel: +420 284 083 111
parker.czechrepublic@parker.com

DE – Germany, Kaarst

Tel: +49 (0)2131 4016 0
parker.germany@parker.com

DK – Denmark, Ballerup

Tel: +45 43 56 04 00
parker.denmark@parker.com

ES – Spain, Madrid

Tel: +34 902 330 001
parker.spain@parker.com

FI – Finland, Vantaa

Tel: +358 (0)20 753 2500
parker.finland@parker.com

FR – France, Contamine s/Arve

Tel: +33 (0)4 50 25 80 25
parker.france@parker.com

GR – Greece, Athens

Tel: +30 210 933 6450
parker.greece@parker.com

HU – Hungary, Budapest

Tel: +36 1 220 4155
parker.hungary@parker.com

IE – Ireland, Dublin

Tel: +353 (0)1 466 6370
parker.ireland@parker.com

IT – Italy, Corsico (MI)

Tel: +39 02 45 19 21
parker.italy@parker.com

KZ – Kazakhstan, Almaty

Tel: +7 7272 505 800
parker.easteurope@parker.com

NL – The Netherlands, Oldenzaal

Tel: +31 (0)541 585 000
parker.nl@parker.com

NO – Norway, Asker

Tel: +47 66 75 34 00
parker.norway@parker.com

PL – Poland, Warsaw

Tel: +48 (0)22 573 24 00
parker.poland@parker.com

PT – Portugal, Leca da Palmeira

Tel: +351 22 999 7360
parker.portugal@parker.com

RO – Romania, Bucharest

Tel: +40 21 252 1382
parker.romania@parker.com

RU – Russia, Moscow

Tel: +7 495 645-2156
parker.russia@parker.com

SE – Sweden, Spånga

Tel: +46 (0)8 59 79 50 00
parker.sweden@parker.com

SK – Slovakia, Banská Bystrica

Tel: +421 484 162 252
parker.slovakia@parker.com

SL – Slovenia, Novo Mesto

Tel: +386 7 337 6650
parker.slovenia@parker.com

TR – Turkey, Istanbul

Tel: +90 216 4997081
parker.turkey@parker.com

UA – Ukraine, Kiev

Tel: +380 44 494 2731
parker.ukraine@parker.com

UK – United Kingdom, Warwick

Tel: +44 (0)1926 317 878
parker.uk@parker.com

ZA – South Africa, Kempton Park

Tel: +27 (0)11 961 0700
parker.southafrica@parker.com

North America

CA – Canada, Milton, Ontario

Tel: +1 905 693 3000

US – USA, Cleveland

Tel: +1 216 896 3000

Asia Pacific

AU – Australia, Castle Hill

Tel: +61 (0)2-9634 7777

CN – China, Shanghai

Tel: +86 21 2899 5000

HK – Hong Kong

Tel: +852 2428 8008

IN – India, Mumbai

Tel: +91 22 6513 7081-85

JP – Japan, Tokyo

Tel: +81 (0)3 6408 3901

KR – South Korea, Seoul

Tel: +82 2 559 0400

MY – Malaysia, Shah Alam

Tel: +60 3 7849 0800

NZ – New Zealand, Mt Wellington

Tel: +64 9 574 1744

SG – Singapore

Tel: +65 6887 6300

TH – Thailand, Bangkok

Tel: +662 186 7000-99

TW – Taiwan, Taipei

Tel: +886 2 2298 8987

South America

AR – Argentina, Buenos Aires

Tel: +54 3327 44 4129

BR – Brazil, Sao Jose dos Campos

Tel: +55 800 727 5374

CL – Chile, Santiago

Tel: +56 2 623 1216

MX – Mexico, Apodaca

Tel: +52 81 8156 6000

European Product Information Centre

Free phone: 00 800 27 27 5374

(from AT, BE, CH, CZ, DE, DK, EE, ES, FI, FR, IE, IL, IS, IT, LU, MT, NL, NO, PL, PT, RU, SE, SK, UK, ZA)

Parker Hannifin Ltd.

Tachbrook Park Drive

Tachbrook Park,

Warwick, CV34 6TU

United Kingdom

Tel.: +44 (0) 1926 317 878

Fax: +44 (0) 1926 317 855

parker.uk@parker.com

www.parker.com

