

**⚠ WARNING**

To avoid unpredictable system behavior that can cause personal injury and property damage:

- Disconnect electrical supply (when necessary) before installation, servicing, or conversion.
- Disconnect air supply and depressurize all air lines connected to this product before installation, servicing, or conversion.
- Operate within the manufacturer's specified pressure, temperature, and other conditions listed in these instructions.
- Medium must be moisture-free if ambient temperature is below freezing.
- Service according to procedures listed in these instructions.
- Installation, service, and conversion of these products must be performed by knowledgeable personnel who understand how pneumatic products are to be applied.
- After installation, servicing, or conversion, air and electrical supplies (when necessary) should be connected and the product tested for proper function and leakage. If audible leakage is present, or the product does not operate properly, do not put into use.
- Warnings and specifications on the product should not be covered by paint, etc. If masking is not possible, contact your local representative for replacement labels.

**Introduction**

Follow these instructions when installing, operating, or servicing the product.

**Application Limits**

These products are intended for use in general-purpose compressed air systems only.

|                            |      |      |      |
|----------------------------|------|------|------|
| <b>Operating Pressure:</b> | kPa  | PSIG | bar  |
| Maximum Inlet Pressure     | 1035 | 150  | 10.0 |
| Minimum Inlet Pressure     | 210  | 30   | 2.0  |

**Ambient Temperature Range:** 4°C to 54°C (40°F to 130°F)

**Voltage Range:** Rated Voltage +10%, -15%

**Symbol**

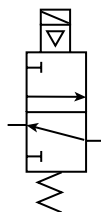

**Installation**

The Solenoid Quick Exhaust valves should be installed with reasonable accessibility for service. Keep pipe or tubing lengths to a minimum with inside clean and free of dirt and chips. Pipe joint compound should be used sparingly and applied only to the male pipe – never into the female port. Do not use PTFE tape to seal pipe joints – pieces have a tendency to break off and lodge inside the unit, possibly causing malfunction. Care should be taken to avoid undue strain on valve.

Air applied to the valve must be filtered with a 40 micron filter to realize maximum component life.

**Life Expectancy** - Normal multi-million cycle life expectancy of these valves is based on the use of properly filtered and lubricated air at room temperature. These valves are also designed to operate under non-lubricated conditions and will yield millions of maintenance free cycles.

**Factory Pre-Lubrication** - Valves are pre-lubricated at assembly with a petroleum based grease which has a lithium content.

**In-Service Lubrication** - In-service lubrication is not required; however, if lubrication is to be used, F442 oil is recommended. This oil is specially formulated to provide peak performance and maximum service life from all air operated equipment. Otherwise, use an air line lubricant (compatible with Nitrile & Polyurethane seals) which will readily atomize and be of the medium aniline type. Aniline point range must be between 180° and 220°F. Viscosity at 100°F: 140 - 170 SUS.

**⚠ CAUTION:** Do not use synthetic, reconstituted, or oils with an alcohol content or detergent additive.

**⚠ CAUTION:** Do not restrict the inlet of valves having an internal pilot supply. Pressure supply piping must be the same size as the inlet port or larger to insure that the pilot valve receives sufficient pressure supply during high flow conditions.

**Accessories**

| <u>Kit No.</u>          | <u>Description</u>     |
|-------------------------|------------------------|
| <b>Metal Mufflers</b>   |                        |
| ES50MB 1/2"             | Exhaust Muffler - S75  |
| ES75MB 3/4"             | Exhaust Muffler - S105 |
| <b>Plastic Mufflers</b> |                        |
| M60-04 1/2"             | Exhaust Muffler - S75  |
| M60-06 3/4"             | Exhaust Muffler - S105 |

**Function**

The Solenoid Quick Exhaust valve is a 3-Port normally closed 3-Way, 2-Position directional control valve, which supplies downstream pressure when the solenoid is energized. Upon de-energizing of the solenoid, the inlet air is blocked and the downstream air is exhausted. The bottom (exhaust) port is tapped 1/2" NPTF on the S75 and 3/4" NPTF on the S105 so that the exhaust may be piped away or fitted with a muffler.

**⚠ WARNING**

**FAILURE OR IMPROPER SELECTION OR IMPROPER USE OF THE PRODUCTS AND/OR SYSTEMS DESCRIBED HEREIN OR RELATED ITEMS CAN CAUSE DEATH, PERSONAL INJURY AND PROPERTY DAMAGE.**

This document and other information from The Company, its subsidiaries and authorized distributors provide product and/or system options for further investigation by users having technical expertise. It is important that you analyze all aspects of your application, including consequences of any failure and review the information concerning the product or systems in the current product catalog. Due to the variety of operating conditions and applications for these products or systems, the user, through its own analysis and testing, is solely responsible for making the final selection of the products and systems and assuring that all performance, safety and warning requirements of the application are met.

The products described herein, including without limitation, product features, specifications, designs, availability and pricing, are subject to change by The Company and its subsidiaries at any time without notice.

**EXTRA COPIES OF THESE INSTRUCTIONS ARE AVAILABLE FOR INCLUSION IN EQUIPMENT / MAINTENANCE MANUALS THAT UTILIZE THESE PRODUCTS. CONTACT YOUR LOCAL REPRESENTATIVE.**

**Wiring Instructions**

**⚠ CAUTION: An interruption of 10 milliseconds or greater to the power supplied to the solenoid of a solenoid operated valve may cause the valve to shift. Provision must be made to prevent power interruption of this duration to avoid unintended, potentially hazardous, consequences.**

**NOTE:** In addition to the following instructions, follow all requirements for local and national electrical codes.

**Electrical Connection**

Valves with 3-Pin male terminals should have power connected to the parallel terminals. Ground should be connected to the perpendicular terminal.

**Override Operation**

The flush non-locking manual override is located on the body of the solenoid pilot. To operate the override, place a small screwdriver in the slot of the override and turn approximately 45° in either direction until the solenoid pilot actuates. The solenoid pilot will remain actuated until the override is released. When released, the solenoid pilot de-actuates.

**Solenoid Replacement**

To replace the solenoid, remove the solenoid nut and pull solenoid off and replace with the correct voltage solenoid. Replace solenoid nut and tighten finger tight. See Figure 1.

| Voltage | Coil No. |
|---------|----------|
| 24VDC   | 2EV103   |
| 24VAC   | 2EV102   |
| 110VAC  | 2EV105   |

**Service**

**⚠ Caution: Disconnect or shut off air and electrical supply and exhaust pressure before servicing unit.**

**⚠ Caution: Grease packets are supplied with kits for lubrication of seals. Use only mineral based grease or oils. Do not use synthetic oils such as esters. Do not use silicones.**

**Dimensions:**

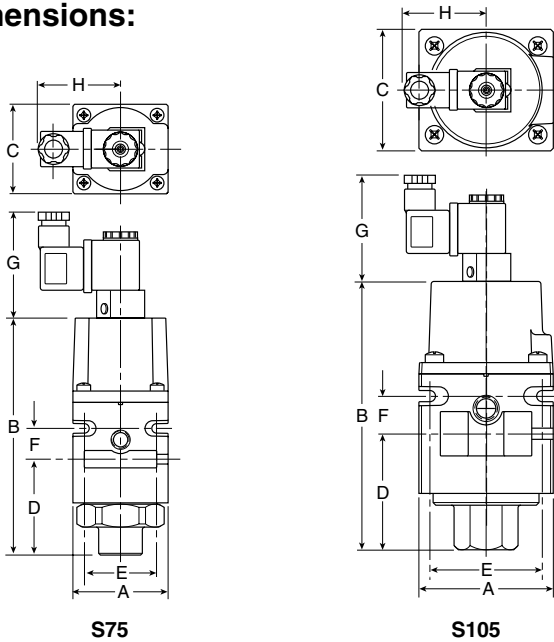

| Model | Port Size | A            | B             | C            | D            | E            | F           | G            | H            |
|-------|-----------|--------------|---------------|--------------|--------------|--------------|-------------|--------------|--------------|
| S75   | 3/8"      | 2.19<br>(56) | 4.72<br>(120) | 2.06<br>(52) | 1.50<br>(38) | 1.66<br>(42) | .72<br>(18) | 2.56<br>(65) | 1.90<br>(48) |
| S105  | 1/2"      | 3.03<br>(77) | 5.25<br>(133) | 2.75<br>(70) | 1.84<br>(47) | 2.53<br>(64) | .84<br>(21) | 2.56<br>(65) | 1.90<br>(48) |

Inches (mm)

Note: After servicing unit, turn on air and electrical supply and check for leaks. If leakage occurs, do not operate – conduct repairs and retest.

Note : Items marked with an \* are included in the service kit.

1. Remove the four Screws that retain the Cover and remove Cover. Next remove Plunger with Seals and Spring from Body.
2. Remove Bottom Plug by unscrewing it from the Body. Next remove Bottom Spring, Disc Holder Assembly and Gasket.
3. Clean, and carefully inspect parts for wear and / or damage. If replacement is necessary, use parts from service kit.
4. Lubricate O-rings and U-cup with grease (supplied with kit).
5. Install Gasket into Body. Then install Disc Holder, Bottom Spring and Bottom Plug into Body. See Figure 1 for torque value.
6. Install Plunger with Seals into the Body. Install two O-rings between Body and Cover (make sure air passages are aligned properly), install four Screws and tighten per Figure 1.

**Service Kits Available:**

| Description | S75   | S105   |
|-------------|-------|--------|
| Service Kit | RKS75 | RKS105 |

There may be extra parts in the kit.

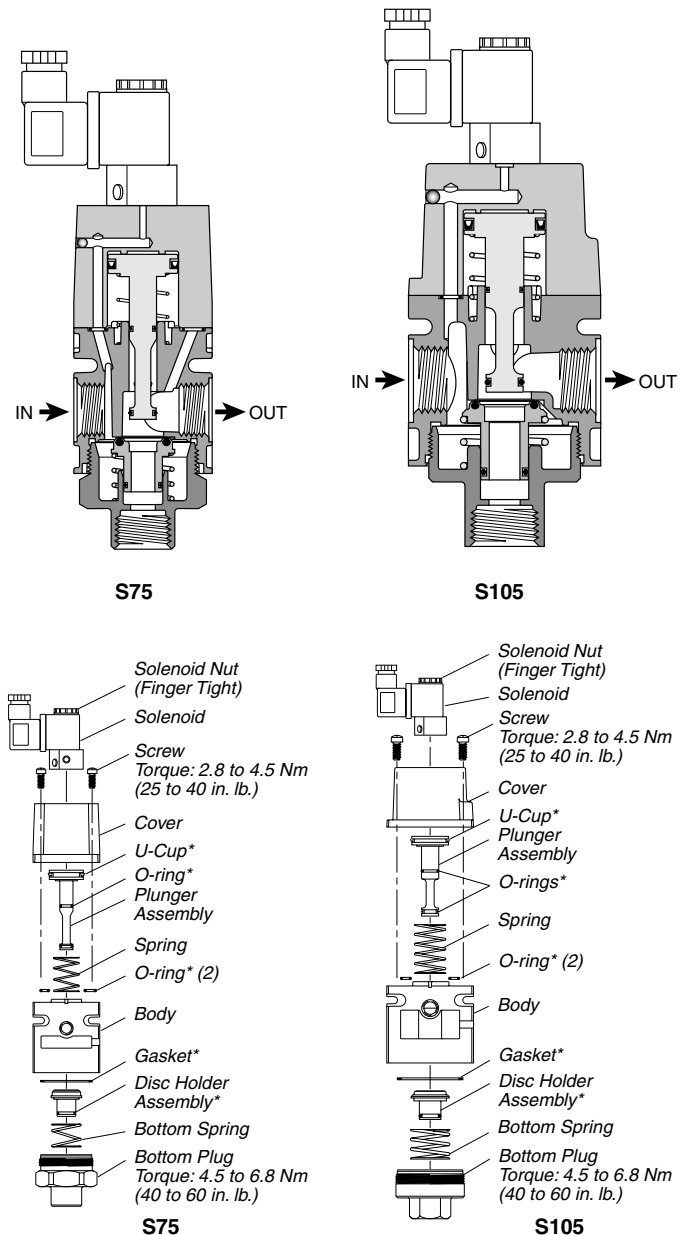

Figure 1