 **WARNING**

To avoid unpredictable system behavior that can cause personal injury and property damage:

- Disconnect electrical supply (when necessary) before installation, servicing, or conversion.
- Disconnect air supply and depressurize all air lines connected to this product before installation, servicing, or conversion.
- Operate within the manufacturer's specified pressure, temperature, and other conditions listed in these instructions.
- Medium must be moisture-free if ambient temperature is below freezing.
- Service according to procedures listed in these instructions.
- Installation, service, and conversion of these products must be performed by knowledgeable personnel who understand how pneumatic products are to be applied.
- After installation, servicing, or conversion, air and electrical supplies (when necessary) should be connected and the product tested for proper function and leakage. If audible leakage is present, or the product does not operate properly, do not put into use.
- Warnings and specifications on the product should not be covered by paint, etc. If masking is not possible, contact your local representative for replacement labels.

Introduction

Follow these instructions when installing, operating, or servicing the product.

Application Limits

These products are intended for use in general purpose compressed air systems only.

Operating Pressure:

	kPa	PSIG	bar
Maximum Inlet Pressure	2068	300	21.0

Operating Temperature Range: 4°C to 66°C (40°F to 150°F)

 **WARNING**

Product rupture can cause serious injury.
Do not connect regulator to bottled gas.
Do not exceed maximum primary pressure rating.

ANSI Symbols

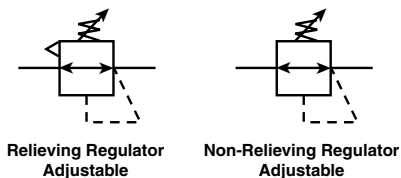

Installation

1. The regulator should be installed with reasonable accessibility for service whenever possible - repair service kits are available. Keep pipe and tubing lengths to a minimum with inside clean and free of dirt and chips. Pipe joint compound should be used sparingly and applied only

to the male pipe - never into the female port. Do not use PTFE tape to seal pipe joints - pieces have a tendency to break off and lodge inside unit, possibly causing malfunction.

2. Install regulator so that air flow is into port labelled "IN". Installation must be upstream (high pressure) side and as close to the devices it is to service (valve, cylinder, tool, etc.) as possible. Mounting may be in any position.
3. Gauge ports are located on both sides of the regulator body for your convenience. It is necessary to install a gauge or pipe plugs into each port during installation.
4. For protection against rust, pipe scale, and other foreign matter, install a filter on the upstream (high pressure) side as close to the regulator as possible.

Operation

1. Before turning on the air supply:
 - 1A. On R364, disengage the adjusting knob by pulling upward. Turn adjusting knob counterclockwise until the compression is released from the pressure control spring.
 - 1B. On R10, push down on the adjusting knob while turning knob counterclockwise until the compression is released from the pressure control spring. (Knob is locked when up.)
2. Then turn on air supply and adjust regulator to desired secondary pressure by turning adjusting knob clockwise. This permits pressure to build up slowly, preventing any unexpected operation of the valve, cylinders, tools, etc., attached to the line. Adjustment to desired secondary pressure can be made only with primary pressure applied to the regulator.
3. To decrease regulator pressure setting, always reset from a pressure lower than the final setting desired. For example, lowering the secondary pressure from 550 to 410 kPa (80 to 60 psig) is best accomplished by dropping the secondary pressure to 350 kPa (50 psig), then adjusting upward to 410 kPa (60 psig).

 **WARNING**

FAILURE OR IMPROPER SELECTION OR IMPROPER USE OF THE PRODUCTS AND/OR SYSTEMS DESCRIBED HEREIN OR RELATED ITEMS CAN CAUSE DEATH, PERSONAL INJURY AND PROPERTY DAMAGE.

This document and other information from The Company, its subsidiaries and authorized distributors provide product and/or system options for further investigation by users having technical expertise. It is important that you analyze all aspects of your application, including consequences of any failure and review the information concerning the product or systems in the current product catalog. Due to the variety of operating conditions and applications for these products or systems, the user, through its own analysis and testing, is solely responsible for making the final selection of the products and systems and assuring that all performance, safety and warning requirements of the application are met.

The products described herein, including without limitation, product features, specifications, designs, availability and pricing, are subject to change by The Company and its subsidiaries at any time without notice.

EXTRA COPIES OF THESE INSTRUCTIONS ARE AVAILABLE FOR INCLUSION IN EQUIPMENT / MAINTENANCE MANUALS THAT UTILIZE THESE PRODUCTS. CONTACT YOUR LOCAL REPRESENTATIVE.

Service

⚠ CAUTION:
SHUT OFF AIR SUPPLY and exhaust the primary and secondary pressure before disassembling regulator unit. (Turning the knob counterclockwise reduces regulator's setting, but does not vent downstream pressure on non-relieving regulators.)

⚠ CAUTION:
Lubricate parts with a mineral based grease / oil or silicone grease. DO NOT use synthetic grease / oils such as esters.

A. Servicing the Bonnet and Diaphragm Assembly-

- 1A. On R364, disengage the adjusting knob by pulling upward. Turn adjusting knob counterclockwise until the compression is released from the pressure control spring.
- 1B. On R10, push down on the adjusting knob while turning knob counterclockwise until the compression is released from the pressure control spring. (Knob is locked when up.)
2. Unscrew the threaded bonnet assembly. Next, disassemble, clean, and carefully inspect parts for wear and/or damage. If replacement is necessary, use parts from service kits.
3. Install diaphragm assembly into body. Then install bonnet assembly to body. See Figure 1 for torque value.

B. Servicing the Poppet Assembly-

1. Exhaust system air pressure as previously described. Then remove bottom plug by unscrewing it from body. Next, remove bottom plug o-ring, spring and poppet assembly.
2. Next, clean, and carefully inspect parts for wear and/or damage. If replacement is necessary, use parts from service kits.

3. Lubricate o-ring and sliding surfaces using grease supplied with service kit.
4. Lubricate bottom plug o-ring and install it in o-ring groove on bottom plug. Then screw bottom plug into body until the plug bottoms out in body. See Figure 1 for torque value.
5. Turn on air supply and adjust to desired secondary pressure as described in the **Operation** section.

Turn on air pressure and check regulator for leakage. If leakage occurs, DO NOT OPERATE — conduct repairs again.

If you have questions concerning how to service this unit, contact your local authorized dealer or your customer service representative.

Service Kits Available

Description	R364 (1/4")	R10 (1/2")
Spring Cage Assembly and Knob	CKR364YSS	CKR10YSS
Gauges	274Y160SS	275Y160SS
Panel Mount Nut	R05X51SS	R10X51SS
Regulator Repair Kit (Relieving)	RKR364YSS	RKR10YSS
Regulator Repair Kit (Non-Relieving)	RKR364KYSS	RKR10KYSS
Spring, 0-25 PSIG	SPR-375-2-SS	—
Spring, 0-60 PSIG	SPR-376-1-SS	SPR-388-1-SS
Spring, 0-125 PSIG	SPR-377-1-SS	SPR-389-1-SS
Spring, 0-250 PSIG	—	SPR-390-1-SS

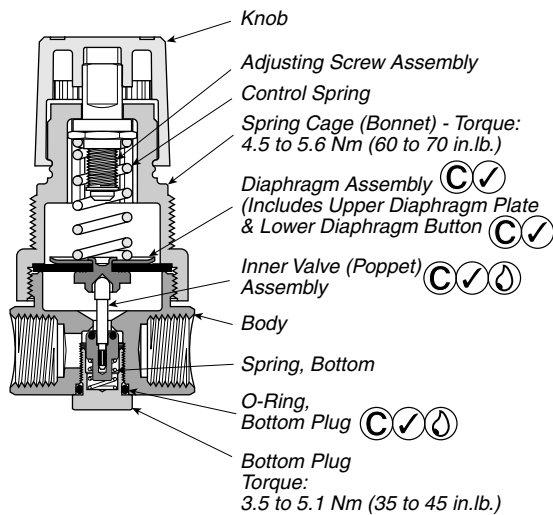

**R364-SS Regulator
(Non-Relieving Shown)**

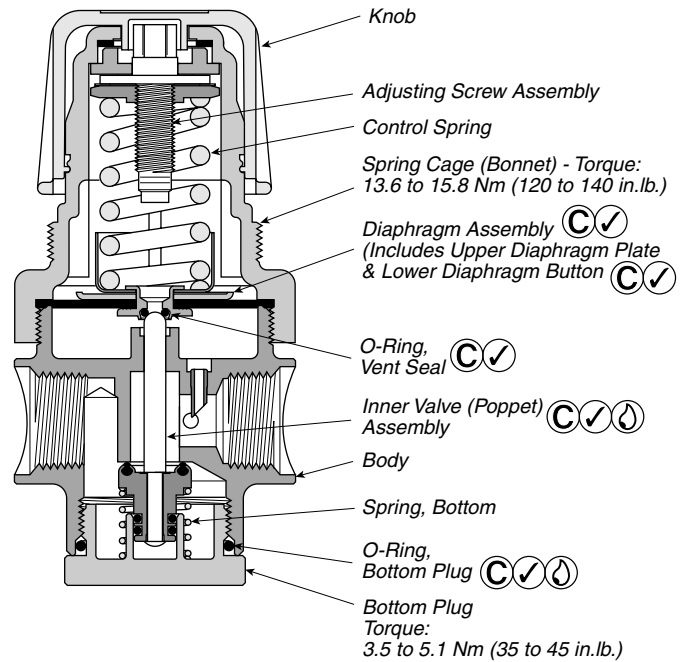

**R10-SS Regulator
(Relieving Shown)**

Figure 1

- ☽ Lightly grease with provided lubricant.
- ☑ Inspect for nicks, scratches, and surface imperfections. If present, reduced service life is probable and future replacement should be planned.
- Ⓒ Clean with lint-free cloth.