

⚠ WARNING

To avoid unpredictable system behavior that can cause personal injury and property damage:

- Disconnect electrical supply (when necessary) before installation, servicing, or conversion.
- Disconnect air supply and depressurize all air lines connected to this product before installation, servicing, or conversion.
- Operate within the manufacturer's specified pressure, temperature, and other conditions listed in these instructions.
- Medium must be moisture-free if ambient temperature is below freezing.
- Service according to procedures listed in these instructions.
- Installation, service, and conversion of these products must be performed by knowledgeable personnel who understand how pneumatic products are to be applied.
- After installation, servicing, or conversion, air and electrical supplies (when necessary) should be connected and the product tested for proper function and leakage. If audible leakage is present, or the product does not operate properly, do not put into use.
- Warnings and specifications on the product should not be covered by paint, etc. If masking is not possible, contact your local representative for replacement labels.

⚠ CAUTION

Polycarbonate bowls, being transparent and tough, are ideal for use with Filters and Lubricators. They are suitable for use in normal industrial environments, but should not be located in areas where they could be subjected to direct sunlight, an impact blow, nor temperatures outside of the rated range. As with most plastics, some chemicals can cause damage. Polycarbonate bowls should not be exposed to chlorinated hydrocarbons, ketones, esters and certain alcohols. They should not be used in air systems where compressors are lubricated with fire-resistant fluids such as phosphate ester and di-ester types.

Metal bowls are recommended where ambient and/or media conditions are not compatible with polycarbonate bowls. Metal bowls resist the action of most such solvents, but should not be used where strong acids or bases are present or in salt laden atmospheres. Consult the factory for specific recommendations where these conditions exist.

TO CLEAN POLYCARBONATE BOWLS USE MILD SOAP AND WATER ONLY! DO NOT use cleansing agents such as acetone, benzene, carbon tetrachloride, gasoline, toluene, etc., which are damaging to this plastic.

Bowl guards are recommended for added protection of polycarbonate bowls where chemical attack may occur.

⚠ WARNING

FAILURE OR IMPROPER SELECTION OR IMPROPER USE OF THE PRODUCTS AND/OR SYSTEMS DESCRIBED HEREIN OR RELATED ITEMS CAN CAUSE DEATH, PERSONAL INJURY AND PROPERTY DAMAGE.

This document and other information from The Company, its subsidiaries and authorized distributors provide product and/or system options for further investigation by users having technical expertise. It is important that you analyze all aspects of your application, including consequences of any failure and review the information concerning the product or systems in the current product catalog. Due to the variety of operating conditions and applications for these products or systems, the user, through its own analysis and testing, is solely responsible for making the final selection of the products and systems and assuring that all performance, safety and warning requirements of the application are met.

The products described herein, including without limitation, product features, specifications, designs, availability and pricing, are subject to change by The Company and its subsidiaries at any time without notice.

EXTRA COPIES OF THESE INSTRUCTIONS ARE AVAILABLE FOR INCLUSION IN EQUIPMENT / MAINTENANCE MANUALS THAT UTILIZE THESE PRODUCTS. CONTACT YOUR LOCAL REPRESENTATIVE.

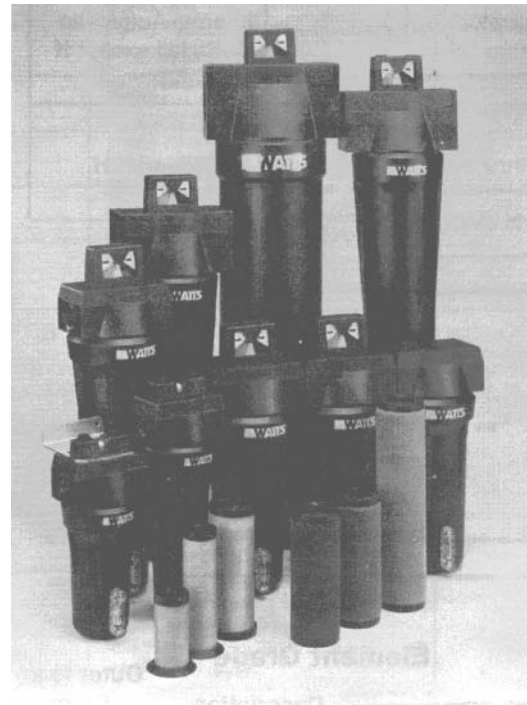

Contents

Part Number Reference 2
 Installation 3
 Operation 5
 Maintenance 6
 Dimensions and Weights 7

General Safety Information

1. Pressurized Devices
 - Read all **WARNINGS** and **CAUTIONS**.
 - Do not exceed maximum operating pressure indicated on serial number tag.
 - Make certain filter is fully depressurized before servicing.
2. Breathing Air
 - Air treated by this equipment may not be suitable for breathing without further purification. Refer to OSHA standard 1910.134 for breathing air requirements.
3. Flammable Gases

WARNING: While the materials of construction are compatible with many flammable gases, the following application limitations must be considered:

 - Housing materials are slightly porous. The product must be used in a well ventilated area in the absence of sparks or ignition sources. Do not use in Class 1, Division 1, Group D environments.
 - The type of area - forced exhaust system used (i.e., high or low level) would be dependent on the gas involved.
 - Each application (other than for air or inert gas) must be reviewed to minimize fire or explosion hazard.

Part Numbering

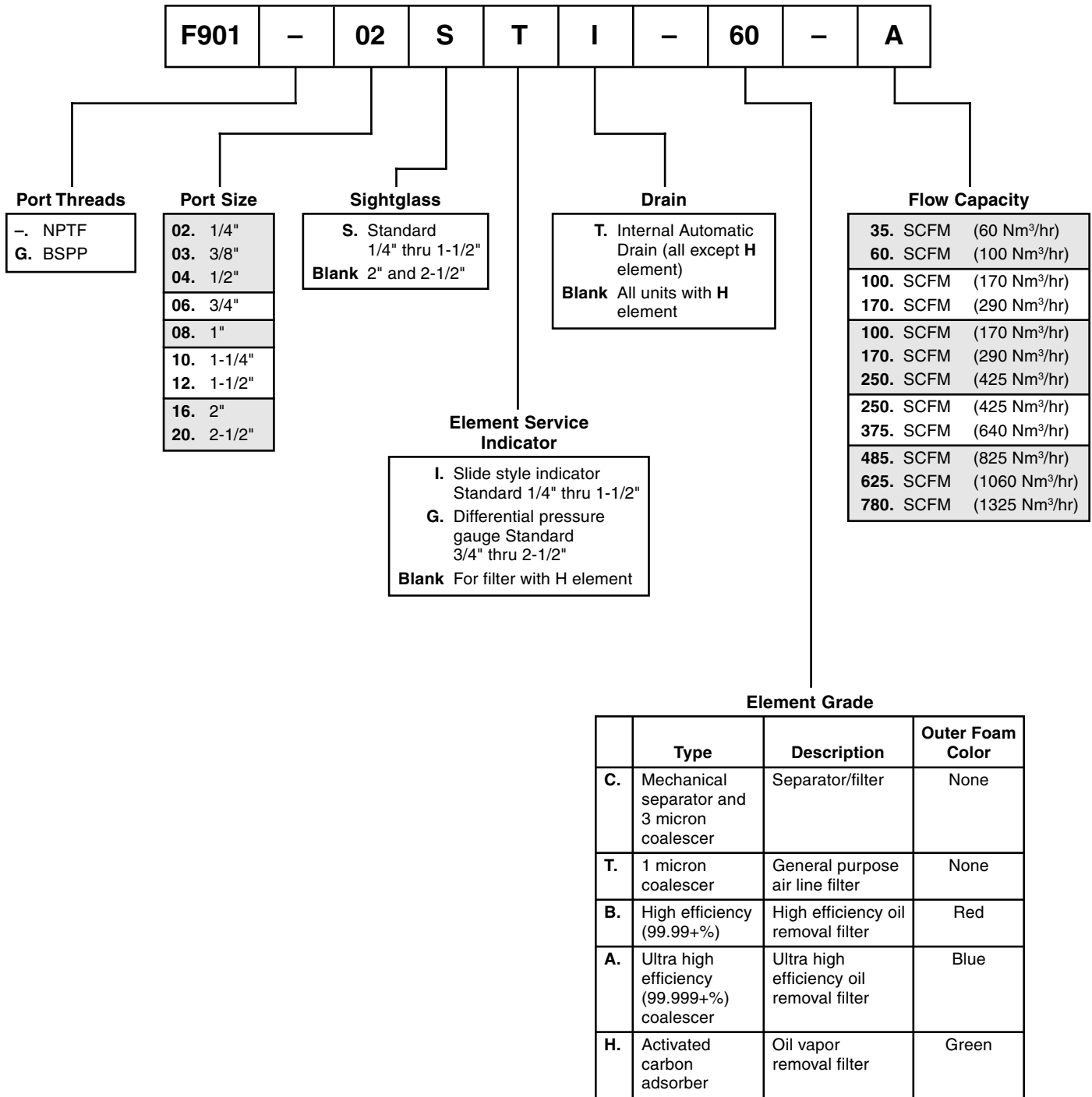

Installation

A. Where Used / Air Quality After Filtration

Grade	Where Used	Solid particle removal (maximum size in microns)	Liquid removal efficiency (at rated conditions)	Maximum inlet liquid loading ppm w/w	Remaining oil content (liquid and vapor) ppm w/w
C	<i>Separator</i> – downstream of an aftercooler <i>Point-of-use</i> – where no aftercooler is installed upstream	3	99+% of water	25,000	5
T	<i>Prefilter</i> – • Alone ahead of desiccant dryers if no oil is present • Ahead of Grade A <i>Afterfilter</i> – downstream of pressure-swing (heatless) desiccant dryers <i>Point-of-use</i> – where aftercooler is installed upstream	1	100% of water	2,000	1
B	<i>Prefilter</i> – alone ahead of desiccant and membrane dryers if oil is present <i>Afterfilter</i> – • Downstream of refrigerated dryer • Downstream of pressure- swing (heatless) desiccant dryers for finer solid particle removal	0.01	99.99% of oil	1,000	0.01
A	<i>Prefilter</i> – ahead of desiccant and membrane dryers if oil is present (use after Grade T to reduce liquid and solids load, prolong element life and ensure filtration efficiency) <i>Afterfilter</i> – downstream of refrigerated dryer	0.01	99.999+% of oil	100	0.001
H	Use a Grade T or Grade B ahead of Grade H to remove any liquid present	0.01	Removes vapors only	No liquid should be present	0.003

Mounting

Wall Mounting

Wall Mounting Brackets – Mount bracket to filter head:

1. Remove four (4) screws holding back plastic top cap to filter head and discard screws.
2. Place bracket on head over plastic cap.
3. Reinstall with screws provided in bracket kit.

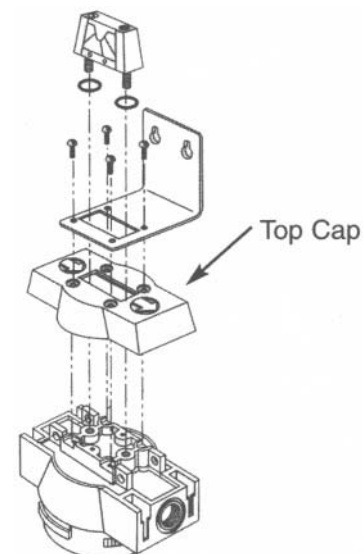

C. Piping

1. Before installing, blow out pipe line to remove scale and other foreign matter.
2. This unit has DRYSEAL pipe threads; use pipe compound or tape sparingly to male threads only.
3. Mounting – Mount so that inlet and outlet connections are horizontal (filter bowl vertical) to ensure proper liquid drainage.
4. Flow Direction – Install so that the air flow is in the direction of arrows on the filter head. Flow through the element is inside out.

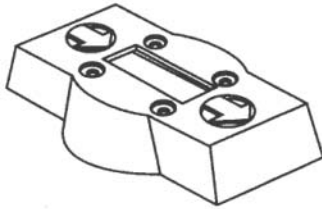

5. Direct Filter-to-Filter (Modular) Connection – Filter heads may be joined without using a pipe nipple.

a. Bayonet Type Heads

Use two (2) modular connectors, o-ring, and four (4) socket head cap screws (sold as kit).

Remove black plastic top cap, apply generous amount of lubricant to o-ring, install o-ring in groove, and insert connectors. Screw connectors to head using socket head cap screws. Reinstall black plastic top cap.

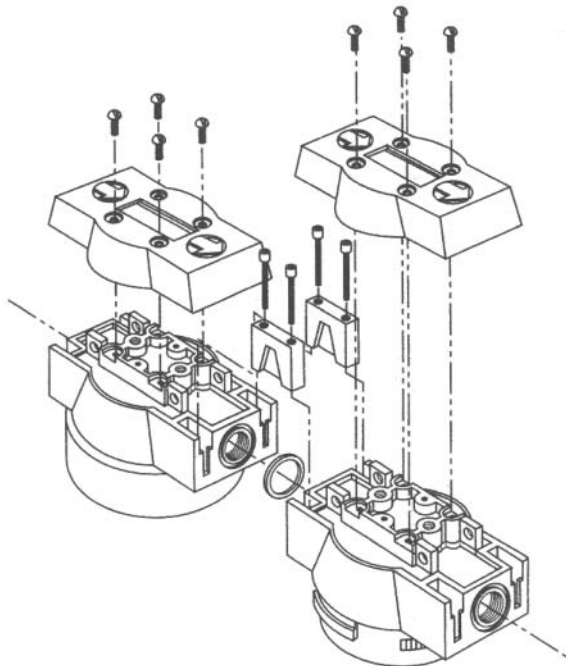

b. Threaded Heads

Use four carriage bolts, nuts and o-ring (sold as kit). Remove black plastic top caps, apply generous amount of lubricant to o-ring, install o-ring in groove, and install bolts and nuts. Reinstall black plastic top cap.

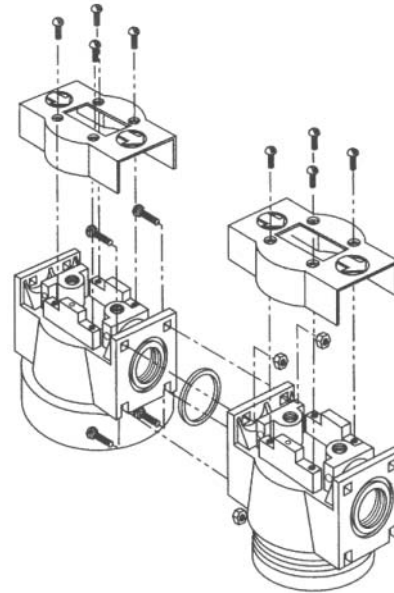

NOTE: Make certain flow direction through filters is correct (pin holes used for aligning top caps should be in the same position on all filters; when hole is in the front, inlet is to the left).

NOTE: Lubricate o-ring with generous amount of lubricant before installation.

6. Isolation Valves and Bypass Piping – For ease of service, isolation and bypass valves are desirable. In critical applications, two filters installed in parallel may be necessary to avoid interruption of air supply.

D. Drain Provisions

1. Internal Automatic Drains – Drain line

The bottom of internal automatic drains are provided with 1/8" NPT (inside threads) for connection of a drain line if desired.

Operation

WARNING: Do not operate filter at pressures in excess of Maximum Working Pressure indicated on unit label.

NOTE: Maximum Operation Temperature – 150°F (66°C). Liquid filtration above 120°F (49°C) is not recommended since there is typically oil present in a vapor state which passes through the filter and condenses downstream.

NOTE: Grade H – If operated above 100°F (38°C) may experience less than 1000 hours of life because of greater oil vapor content.

A. Liquid Draining – Grades C, T, B, A

NOTE: Collected liquids must be removed to ensure proper operation.

NOTE: Depressurize slowly, to avoid filter element damage.

1. Manual Drain – Turn to your right (clockwise) to open, and to your left (counterclockwise) to close.
2. Automatic Drains – Liquids will automatically discharge when sufficient accumulation occurs.
 - a. Internal Auto Drains – These drains may be manually drained by turning to your right (clockwise) to open, and to your left (counterclockwise) to close.

NOTE: Manually drain internal auto drains daily to verify drain function.

B. Operational Checkpoints

Grades C, T, B, A

1. Check pressure drop across the filter.
 - a. Pressure differential in excess of 10 psi (0.7 kgf/cm²) – *pressure indicator in red area* – indicates that the filter sleeve or element should be replaced.

NOTE: Element should be changed annually or when indicator changes to red, whichever occurs first.

NOTE: Pressure drop should never exceed 50 psi (3.5 kgf/cm²).

- b. Check for sudden reduction in pressure drop. This might indicate:
 - (1) Possible leak across element o-ring seal.
 - (2) Leak through the element due to physical damage.
2. Check flow, pressure, and temperature to make certain filter is being operated within design conditions.
3. Check to see that filter is installed level to ensure proper drainage.
4. Check that manual drains are drained periodically, or that automatic drains are functioning.

Grade H

1. Check for an oily smell by opening the manual drain valve. If an oily smell exists, the following should be checked:
 - a. Filter element adsorption capacity exhausted
 - b. Leak across element o-ring seal
 - c. Leak through element due to physical damage
 - d. Presence of liquids because of lack of, or failure of, prefilters
 - e. Flow, pressure, and temperatures outside design conditions
 - f. Presence of gaseous impurities which cannot be adsorbed

CAUTION: Methane, carbon monoxide, carbon dioxide, and various inorganic gases cannot be removed by a Grade H filter.

Maintenance

A. When to Replace Filter Element

NOTE: Complete element is replaced

1. Grades C, T, B, A

- Initial (dry) pressure drop: 1 to 2 psi (0.07 to 0.14 kgf/cm²)
- Operating pressure drop: As filter becomes liquid loaded (wetted), pressure drop will increase to 2 to 6 psi (0.14 to 0.42 kgf/cm²). Further pressure drop occurs as element loads with solid particles.

FOR MAXIMUM FILTRATION EFFICIENCY, REPLACE ELEMENT WHEN PRESSURE DROP REACHES 10 PSI (0.7 KGF/CM²) (INDICATOR IN RED AREA) OR ANNUALLY, WHICHEVER OCCURS FIRST.

NOTE: Pressure drop may temporarily increase when flow is resumed after flow stoppage. Pressure drop should return to normal within one hour.

NOTE: During normal operation, bottom of foam sleeve will have a band of oil. Spotting above the band indicates that liquids are accumulating faster than they can be drained, and that prefiltration is required.

2. Grade H

- Adsorption Capacity – 1000 hours at rated capacity. Element life is exhausted when odor can be detected downstream of the filter.

B. Procedure for Element Replacement

WARNING: THIS FILTER IS A PRESSURE CONTAINING DEVICE. DEPRESSURIZE BEFORE SERVICING. If filter has not been depressurized before disassembly, an audible alarm will sound when the bowl begins to be removed from the head. If this occurs, stop disassembly, isolate and completely depressurize filter before proceeding.

- Isolate filter (close inlet and outlet valves if installed) or shut off air supply.
- Depressurize filter by slowly opening manual drain valve.
- Remove bowl
 - For models 35 through 170 SCFM – bayonet mount – push bowl up, turn bowl 1/8 turn to your left, and pull bowl straight down.
 - For models 250 SCFM and larger – threaded bowls – unscrew bowl from head using hand, strap wrench or C spanner.

- Clean filter bowl
- Replace element
 - Replacing complete element
 - Pull off old element and discard
 - Make certain o-ring inside top of replacement element is in place, and push element onto filter head.

NOTE: B, A, and H – Do not handle elements by outside foam cover. Handle by bottom end cap only.

- After making certain that the o-ring is inside top of bowl (and on bayonet mount heads that the wave spring is in place), reassemble bowl to head.

NOTE: Make certain o-ring is generously lubricated.

NOTE: Wave spring ends should be pointed toward bottom of bowl to prevent the wave spring from interfering with reassembly.

NOTE: Threaded bowl to head connection, generously lubricate threads with a high grade/temperate lubricate 150°F (66°C).

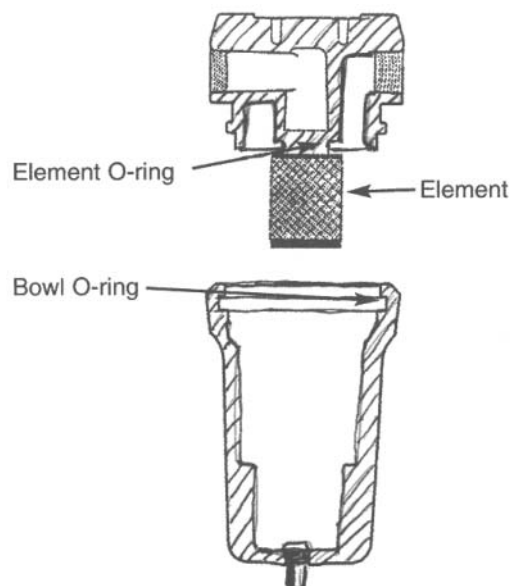

All Grades - Element Replacement

C. Auto Drain Mechanism

It is recommended that drain mechanism be replaced annually.

Dimensions and Weights

Flow SCFM (Nm ³ /hr)	Port Sizes (in inches)		A	B	C	C \diamond	D	Bowl Capacity	Weight
35 (60)	1/4, 3/8, 1/2	in.	4-1/8	7-3/4	8-5/8	11-5/8	11-3/16	20 oz.	3.0 lb.
		mm	105	197	219	295	284	59 cL	1.4 kg
60 (100)	1/4, 3/8, 1/2	in.	4-1/8	10-1/8	11	14	13-7/16	30 oz.	3.5 lb.
		mm	105	257	279	356	341	89 cL	1.6 kg
100 (170)	3/4, 1	in.	5-1/4	10-13/16	11-3/4	14-3/4	15-3/8	55 oz.	3.3 lb.
		mm	133	275	298	375	391	207 cL	1.5 kg
170 (290)	3/4, 1	in.	5-1/4	15-3/32	16	19	19-5/8	80 oz.	3.8 lb.
		mm	133	383	406	483	498	237 cL	1.7 kg
250 (425)	1, 1, 1fi	in.	6-7/16	18-5/32	19	25	22-13/16	150 oz.	5.0 lb.
		mm	164	410	483	635	579	448 cL	2.2 kg
375 (640)	1, 1fi	in.	6-7/16	22-5/8	23-7/16	29-7/16	27-5/16	190 oz.	6.0 lb.
		mm	164	575	595	748	694	560 cL	2.7 kg
485 (825)	2, 2fi	in.	7-5/8	25-13/16	26-11/16	32-11/16	31	283 oz.	20.0 lb.
		mm	194	656	678	830	787	837 cL	9.1 kg
625 (1060)	2fi	in.	7-5/8	31-9/16	32-7/16	38-7/16	36-3/4	352 oz.	24.0 lb.
		mm	194	802	824	976	933	1040 cL	10.9 kg
780 (1325)	2fi	in.	7-5/8	37-3/4	38-9/16	44-9/16	42-7/8	425 oz.	29.0 lb.
		mm	194	959	979	1132	1089	1260 cL	13.2 kg

NOTE: C \diamond is service dimension for clearance necessary below pipe centerline for changing element.

1/4" through 1/2" port sizes
35 SCFM and 60 SCFM
(60 Nm³/hr and 100 Nm³/hr)

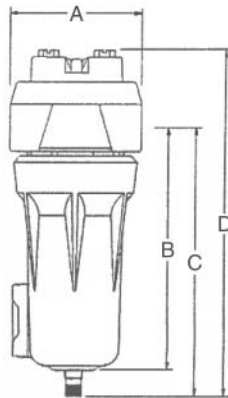

3/4" through 1-1/2" port sizes
100 SCFM through 375 SCFM
(170 Nm³/hr through 640 Nm³/hr)

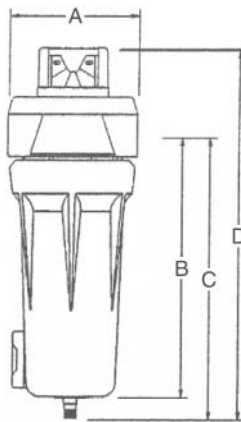

2" through 2-1/2" port sizes
485 SCFM through 780 SCFM
(825 Nm³/hr through 1325 Nm³/hr)

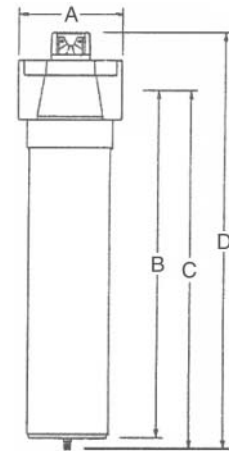

Replacement Elements

Flow SCFM (Nm ³ /hr)	Type C 3 Micron Separator/Filter	Type A 0.01 Micron Ultra Coalescer	Type B 0.01 Micron Coalescer	Type T 1 Micron Coalescer	Type H Activated Carbon
35 (60)	F901-35C-0771	F901-35A-0771	F901-35B-0771	F901-35T-0771	F901-35H-0771
60 (100)	F901-60C-0771	F901-60A-0771	F901-60B-0771	F901-60T-0771	F901-60H-0771
100 (170)	F901-100C-0771	F901-100A-0771	F901-100B-0771	F901-100T-0771	F901-100H-0771
170 (290)	F901-170C-0771	F901-170A-0771	F901-170B-0771	F901-170T-0771	F901-170H-0771
250 (425)	F901-250C-0771	F901-250A-0771	F901-250B-0771	F901-250T-0771	F901-250H-0771
375 (640)	F901-375C-0771	F901-375A-0771	F901-375B-0771	F901-375T-0771	F901-375H-0771
485 (825)	F901-485C-0771	F901-485A-0771	F901-485B-0771	F901-485T-0771	F901-485H-0771
625 (1060)	F901-625C-0771	F901-625A-0771	F901-625B-0771	F901-625T-0771	F901-625H-0771
780 (1325)	F901-780C-0771	F901-780A-0771	F901-780B-0771	F901-780T-0771	F901-780H-0771

Standard Features

	Port Size									
	1/4"	3/8"	1/2"	3/4"	1"	1 ² "	1-1/4"	1-1/2"	2"	2-1/2"
Differential Pressure Slide	█									
Differential Pressure Gauge				█						
Bayonet Mount Bowl	█									
Threaded Bowl Connection	█									
Bowl Sightglass					█					
Internal Automatic Drain Except units w/H element	█									
Modular Connections	█									
Direct Manifold Mount					█					

¹ Note: 100 and 170 SCFM Flow
² Note: 250 SCFM Flow

Materials of Construction

	Port Size									
	1/4"	3/8"	1/2"	3/4"	1"	1 ² "	1-1/4"	1-1/2"	2"	2-1/2"
Body	Zinc			Aluminum						
Bowl	Aluminum								Steel	
Seals (except drain)	Buna-N									
Seals (drain)	Viton									
Filter Head Cover	Polypropylene									
Wave Spring	Steel									
Sightglass	Polyurethane									

¹ Note: 100 and 170 SCFM Flow
² Note: 250 SCFM Flow

Maximum Operating Pressure: 250 PSIG (17 bar)

Minimum Operating Pressure: 30 PSIG (2 bar)

Maximum Operating Temperature: 150°F (66°C)

STANDARD PRODUCT WARRANTY – the Company warrants each product against defects in material and workmanship for a period of one year from the date of original shipment. In event of such defects within the warranty period, the Company will, at its option, replace or recondition the product without charge. This shall constitute the exclusive remedy for breach of warranty, and the Company shall not be responsible for any incidental or consequential damages, including without limitation damages or other costs resulting from labor charges, delays, vandalism, negligence, fouling caused by foreign material, damage from adverse air conditions, chemicals or any other circumstances over which the Company has no control. This warranty shall be invalidated by any abuse, misuse, misapplication or improper installation of the product. **THE COMPANY MAKES NO OTHER WARRANTY. ALL OTHER WARRANTIES, ORAL OR WRITTEN, EXPRESSED OR IMPLIED, INCLUDING WARRANTIES OF MERCHANTABILITY OR FITNESS FOR A SPECIFIC PURPOSE ARE HEREBY EXCLUDED AND DISCLAIMED. IN NO EVENT SHALL THE COMPANY BE LIABLE FOR INCIDENTAL OR CONSEQUENTIAL DAMAGES.** The Company reserves the right to make changes without prior notification. The liability of the Company for all loss or damage resulting from non-confirming goods or tender, including breach of any and all warranties, shall be limited to refund of the purchase price of the particular goods with respect to which the loss or damage occurred.