

Characteristics

Pilot operated pressure relief valves series R4V (TÜV) (DIN 24340 Form D) and R6V (TÜV) (DIN 24340 Form E) include a certification according to directive 2014/68/EU for the usage for safety-related applications.

The valve is set and sealed by the German technical inspection association TÜV. The valve delivery includes the TÜV certificate of conformity.

For series R6V a vent function with a solenoid operated directional valve is available for circulation at minimum pressure.

Features

- TÜV certificate
- Pilot operated with manual adjustment
- 2 interfaces:
 - R4V subplate ISO 6264 (DIN 24340 Form D)
 - R6V subplate ISO 6264 (DIN 24340 Form E) with CETOP 03 vent valve
- Adjustment leaved (code W)
- Adjustment leaved to maximum pressure, lower pressure possible (code V)



R4V06



R6V06 with vent valve



R4V06



Name plate data

Example R4V06

- 415 mm² : minimum opening width
- L220 l/min : max. flow
- 70 bar : set pressure (compare p/Q curves)
- 7,3 mm : cartridge stroke
- 10 % : permitted pressure increase of the flow range

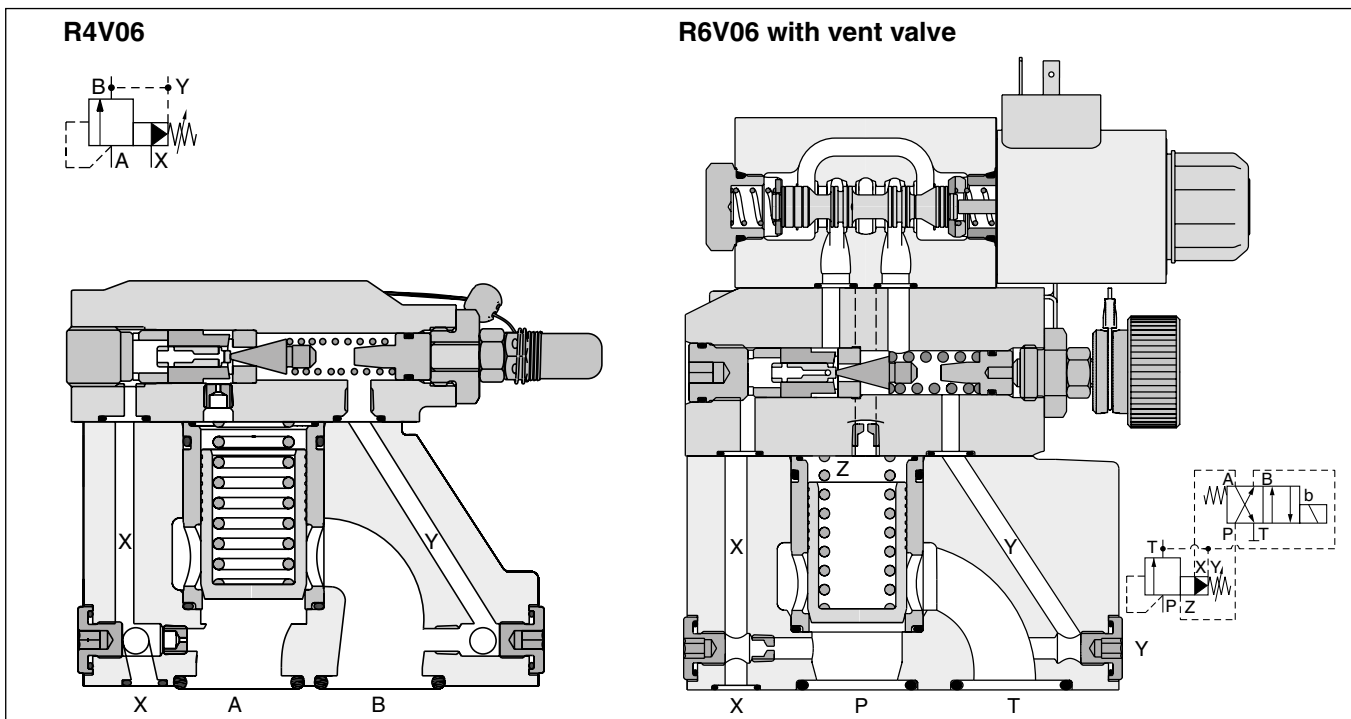

R4V / R6V

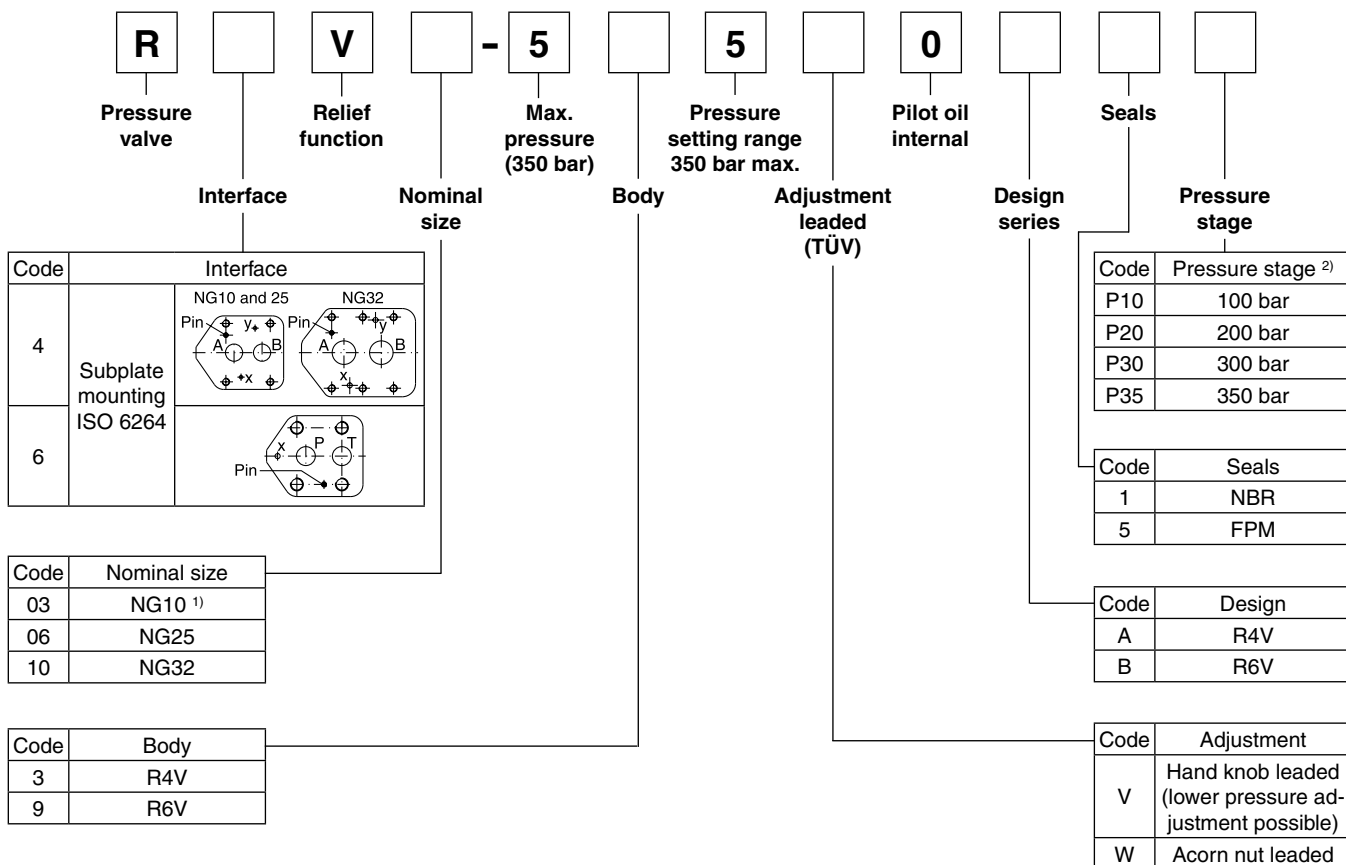

4

R6V with vent valve

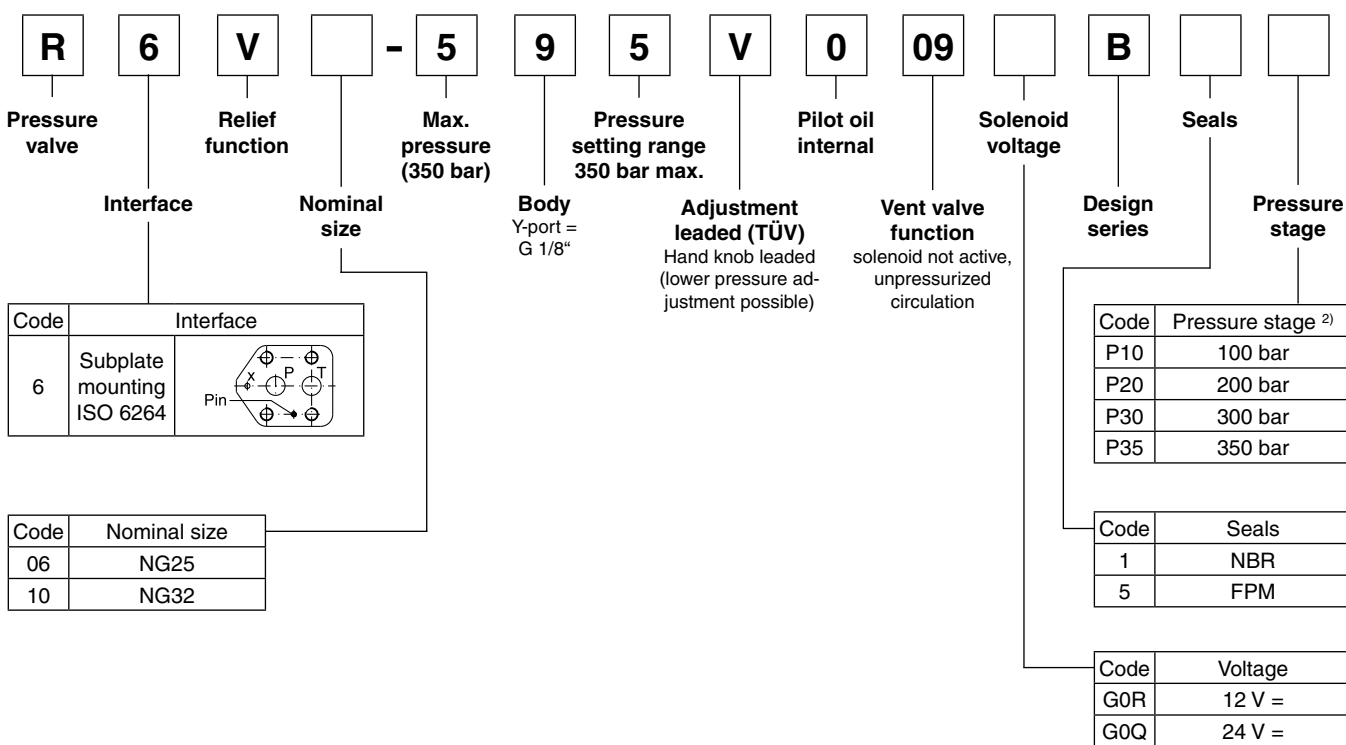

¹⁾ Not for R6V.

²⁾ Further pressure stages on request (in 10 bar steps).

R4V / R6V

General			NG10	NG25	NG32
Nominal size					
Interface			Subplate mounting acc. ISO 6264		
Mounting position			Unrestricted, horizontal mounting preferred		
Ambient temperature	[°C]		-20...+60		
MTTF _D value	[years]		75		
Weight	Series R6V [kg] Series R4V [kg]		— 2.7	5.8 4.5	7.8 6.0
Hydraulic					
Max. operating pressure	[bar]		Ports P (or A) up to 350, Port T (or B) and Y 30		
Pressure stages	[bar]		350 (pressure setting see ordering code)		
Max. flow	R6V [l/min] R4V [l/min]		— 110	500 450	500 500
Fluid			Hydraulic oil according to DIN 51524		
Fluid temperature	[°C]		-10...+70		
Viscosity, permitted	[cSt] / [mm ² /s]		20 ... 400		
recommended	[cSt] / [mm ² /s]		30 ... 80		
Filtration			ISO 4406; 18/16/13		

R6V with vent function

General			NG25	NG32
Nominal size				
Interface			Subplate mounting acc. ISO 6264	
Mounting position			Unrestricted, horizontal mounting preferred	
Ambient temperature	[°C]		-20...+60	
MTTF _D value	[years]		75	
Weight	[kg]		7.2	9.2
Hydraulic				
Max. operating pressure	[bar]		Ports P up to 350, port T and Y 30	
Pressure stages	[bar]		350 (pressure setting see ordering code)	
Max. flow	[l/min]		500	
Fluid			Hydraulic oil according to DIN 51524	
Viscosity, permitted	[cSt] / [mm ² /s]		20 ... 400	
recommended	[cSt] / [mm ² /s]		30 ... 80	
Fluid temperature	[°C]		-10 ... +70	
Filtration			ISO 4406; 18/16/13	
Electrical				
Duty ratio	[%]		100 ED; CAUTION: coil temperature up to 150 °C possible	
Protection class			IP65 in accordance with EN 60529 (with correctly mounted plug-in connector)	
Code			G0R	G0Q
Supply voltage	[V]		12 V =	24 V =
Tolerance supply voltage	[%]		±10	±10
Power consumption	hold [W] in rush [W]		32.7 32.7	31 31
Solenoid connection			Connector as per EN 175301-803	
Wiring min.	[mm ²]		3 x 1.5 recommended	
Wiring length max.	[m]		50 recommended	

R4V/ R6V minimum pressure curve ¹⁾

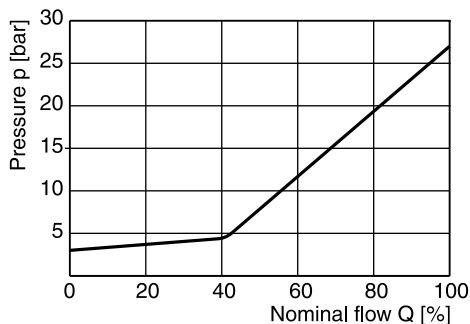

All characteristic curves measured with HLP46 at 50 °C.

¹⁾ The performance curves are measured with external drain.
 For internal drain the tank pressure has to be added to curve.

p/Q performance curves ¹⁾

R4V03

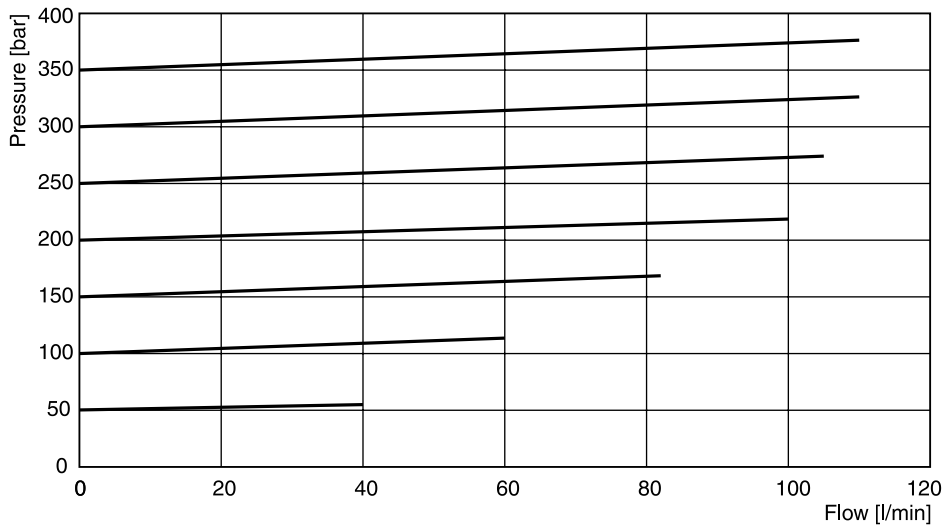

R4V03 nameplate data

Pressure stage	Q _{max}	min. opening width	Cartridge stroke	Permitted pressure increase
50 - 70 bar	40 l/min	154 mm ²	4.4 mm	10 %
80 - 120 bar	60 l/min	154 mm ²	4.4 mm	10 %
130 - 170 bar	82 l/min	154 mm ²	4.4 mm	10 %
180 - 200 bar	100 l/min	154 mm ²	4.4 mm	10 %
210 - 250 bar	105 l/min	154 mm ²	4.4 mm	10 %
260 - 300 bar	110 l/min	154 mm ²	4.4 mm	10 %
310 - 350 bar	110 l/min	154 mm ²	4.4 mm	10 %

R4V06

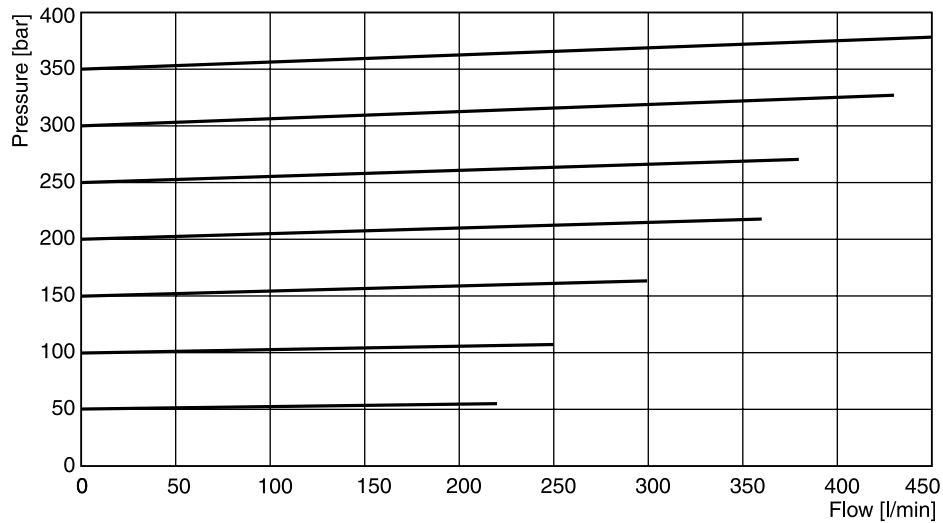

R4V06 nameplate data

Pressure stage	Q _{max}	min. opening width	Cartridge stroke	Permitted pressure increase
50 - 70 bar	220 l/min	415 mm ²	7.3 mm	10 %
80 - 120 bar	250 l/min	415 mm ²	7.3 mm	10 %
130 - 170 bar	300 l/min	415 mm ²	7.3 mm	10 %
180 - 200 bar	360 l/min	415 mm ²	7.3 mm	10 %
210 - 250 bar	380 l/min	415 mm ²	7.3 mm	10 %
260 - 300 bar	430 l/min	415 mm ²	7.3 mm	10 %
310 - 350 bar	450 l/min	415 mm ²	7.3 mm	10 %

¹⁾ The performance curves are measured with external drain.
 For internal drain the tank pressure has to be added to curve.

p/Q performance curves ¹⁾

R4V10

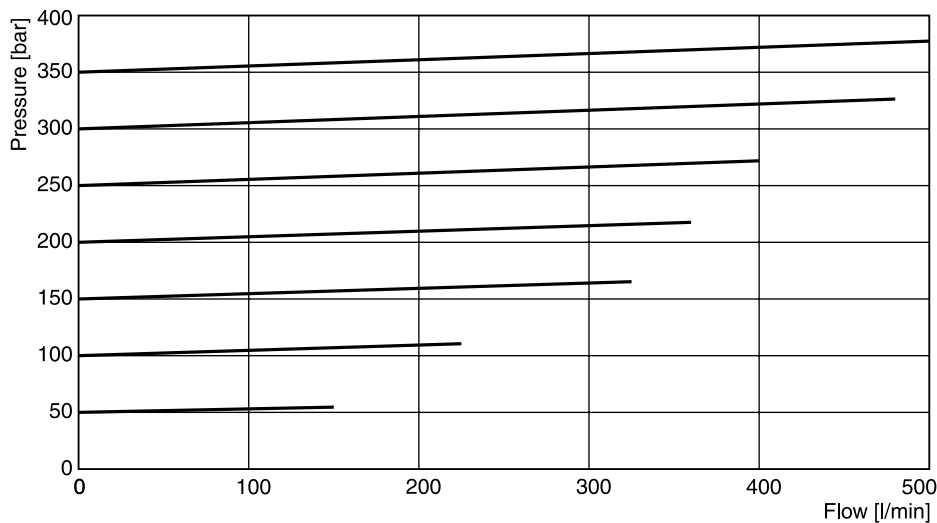

R4V10 nameplate data

Pressure stage	Q _{max}	min. opening width	Cartridge stroke	Permitted pressure increase
50 - 70 bar	150 l/min	607 mm ²	7.3 mm	10 %
80 - 120 bar	225 l/min	607 mm ²	7.3 mm	10 %
130 - 170 bar	325 l/min	607 mm ²	7.3 mm	10 %
180 - 200 bar	360 l/min	607 mm ²	7.3 mm	10 %
210 - 250 bar	400 l/min	607 mm ²	7.3 mm	10 %
260 - 300 bar	480 l/min	607 mm ²	7.3 mm	10 %
310 - 350 bar	500 l/min	607 mm ²	7.3 mm	10 %

R6V06

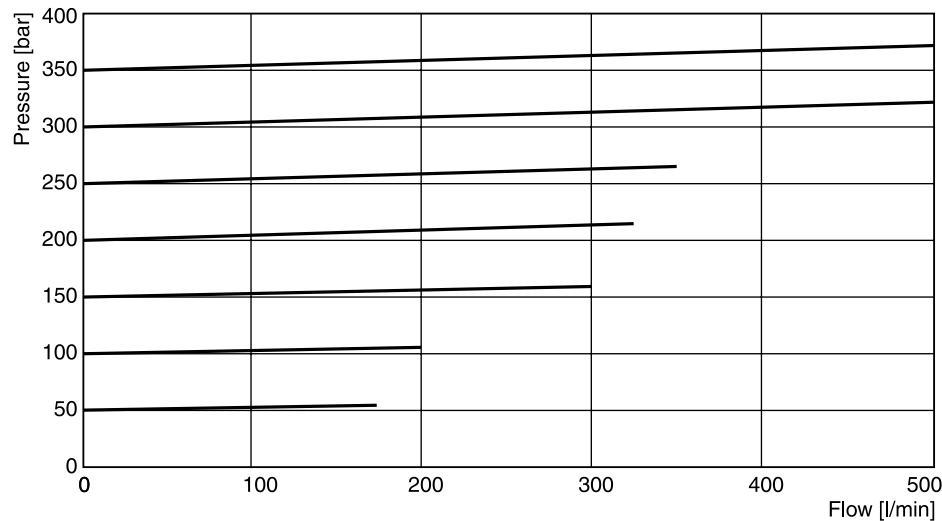

R6V06 nameplate data

Pressure stage	Q _{max}	min. opening width	Cartridge stroke	Permitted pressure increase
50 - 70 bar	170 l/min	415 mm ²	7.3 mm	10 %
80 - 120 bar	200 l/min	415 mm ²	7.3 mm	10 %
130 - 170 bar	300 l/min	415 mm ²	7.3 mm	10 %
180 - 200 bar	325 l/min	415 mm ²	7.3 mm	10 %
210 - 250 bar	350 l/min	415 mm ²	7.3 mm	10 %
260 - 300 bar	500 l/min	415 mm ²	7.3 mm	10 %
310 - 350 bar	500 l/min	415 mm ²	7.3 mm	10 %

¹⁾ The performance curves are measured with external drain.
 For internal drain the tank pressure has to be added to curve.

p/Q performance curves ¹⁾

R6V10

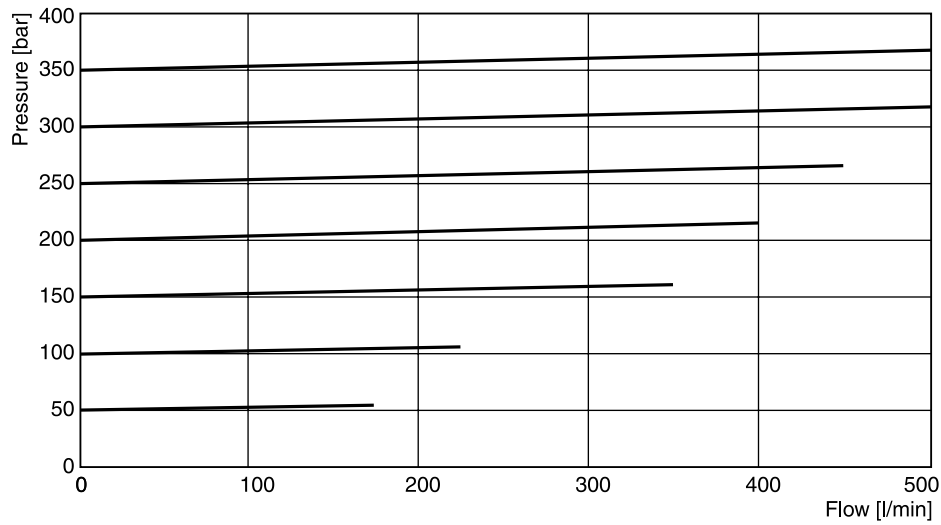

R6V10 nameplate data

Pressure stage	Q _{max}	min. opening width	Cartridge stroke	Permitted pressure increase
50 - 70 bar	170 l/min	607 mm ²	7.3 mm	10 %
80 - 120 bar	225 l/min	607 mm ²	7.3 mm	10 %
130 - 170 bar	350 l/min	607 mm ²	7.3 mm	10 %
180 - 200 bar	400 l/min	607 mm ²	7.3 mm	10 %
210 - 250 bar	450 l/min	607 mm ²	7.3 mm	10 %
260 - 300 bar	500 l/min	607 mm ²	7.3 mm	10 %
310 - 350 bar	500 l/min	607 mm ²	7.3 mm	10 %

¹⁾ The performance curves are measured with external drain.
 For internal drain the tank pressure has to be added to curve.

R6V

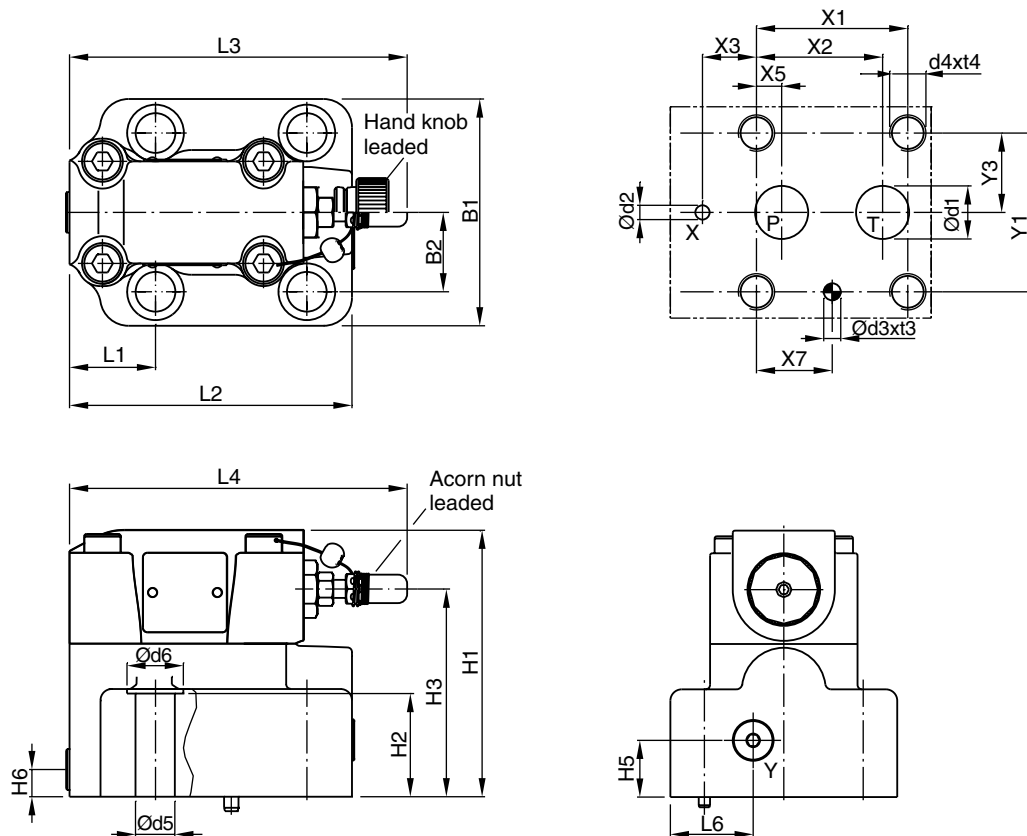

Y: external drain port G 1/8"

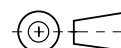

NG	ISO-code	x1	x2	x3	x4	x5	x6	x7	y1	y2	y3	y4	y5	y6
25	6264-08-13-* ⁻⁹⁷	66.7	55.6	23.8	–	11.1	–	33.4	70	–	35	–	–	–
32	6264-10-17-* ⁻⁹⁷	88.9	76.2	31.8	–	12.7	–	44.5	82.6	–	41.3	–	–	–

Tolerance at X and Y pin holes and screw holes ±0.1, at port holes ±0.2.

NG	ISO-code	B1	B2	H1	H2	H3	H4	H5	H6	L1	L2	L3	L4	L6
25	6264-08-13-* ⁻⁹⁷	100	35	117.5	46.5	91.5	–	25	12	37.9	124.5	141	144.8	36.5
32	6264-10-17-* ⁻⁹⁷	120	41.3	124.5	51.3	98.5	–	26.5	13.5	44.3	153	141	144.8	46.5

NG	ISO-code	d1max	d2max	d3	t3	d4	t4	d5	d6	Subplate ¹⁾
25	6264-08-13-* ⁻⁹⁷	23.4	6.3	7.5	10	M16	27	17.5	25	SPP 6R10B 910
32	6264-10-17-* ⁻⁹⁷	32	6.3	7.5	10	M18	28	20	30	SPP 10R12B 910

NG	Bolt kit			Kit		Surface finish
				NBR	FPM	
25	BK366	4x M16x70 ISO 4762-12.9	264 Nm ±15 %	S26-96396-0	S26-96396-5	$\sqrt{R_{max}6.3}$
32	BK507	4x M18x75 ISO 4762-12.9	398 Nm ±15 %	S26-96392-0	S26-96392-5	

¹⁾ Details see chapter 12, series SPP.

R6V with vent function

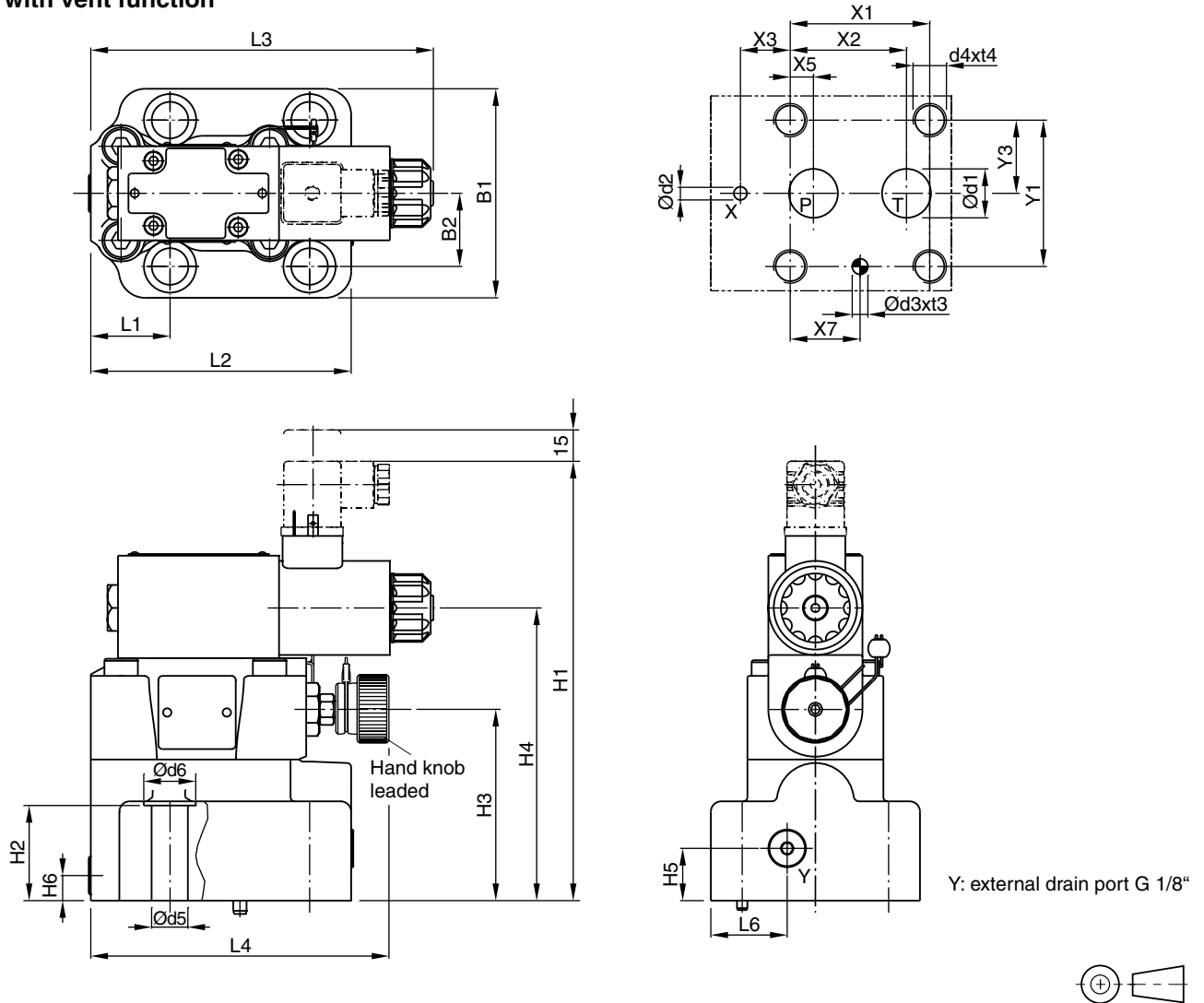



4

NG	ISO-code	x1	x2	x3	x4	x5	x6	x7	y1	y2	y3	y4	y5	y6
25	6264-08-13-*-97	66.7	55.6	23.8	-	11.1	-	33.4	70	-	35	-	-	-
32	6264-10-17-*-97	88.9	76.2	31.8	-	12.7	-	44.5	82.6	-	41.3	-	-	-

Tolerance at X and Y pin holes and screw holes ± 0.1 , at port holes ± 0.2 .

NG	ISO-code	B1	B2	H1	H2	H3	H4	H5	H6	L1	L2	L3	L4	L6
25	6264-08-13-*-97	100	35	206.9	46.5	91.5	139.8	25	12	37.9	124.5	163.8	141	36.5
32	6264-10-17-*-97	120	41.3	213.9	51.3	98.5	146.8	25	12	44.3	153	163.8	141	36.5

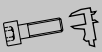
NG	ISO-code	d1max	d2max	d3	t3	d4	t4	d5	d6	Subplate ¹⁾
25	6264-08-13-*-97	23.4	6.3	7.5	10	M16	27	17.5	25	SPP 6R10B 910
32	6264-10-17-*-97	32	6.3	7.5	10	M18	28	20	30	SPP 10R12B 910

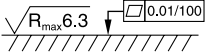
NG	Bolt kit			Kit		Surface finish
				NBR	FPM	
25	BK366	4x M16x70 ISO 4762-12.9	264 Nm ± 15 %	S26-96396-0	S26-96396-5	
32	BK507	4x M18x75 ISO 4762-12.9	398 Nm ± 15 %	S26-96392-0	S26-96392-5	

¹⁾ Details see chapter 12, series SPP.

R4V

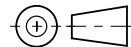
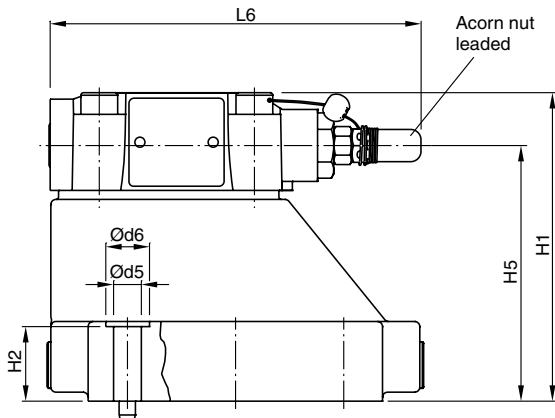
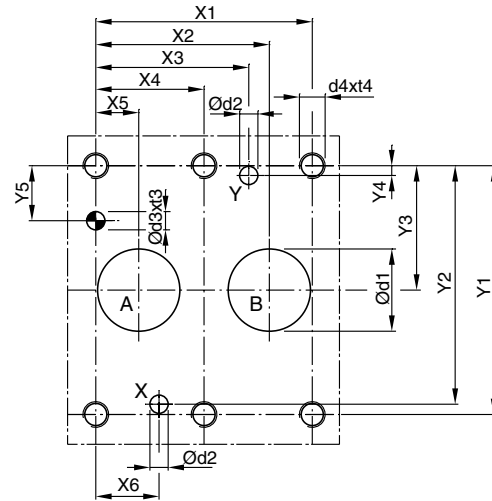
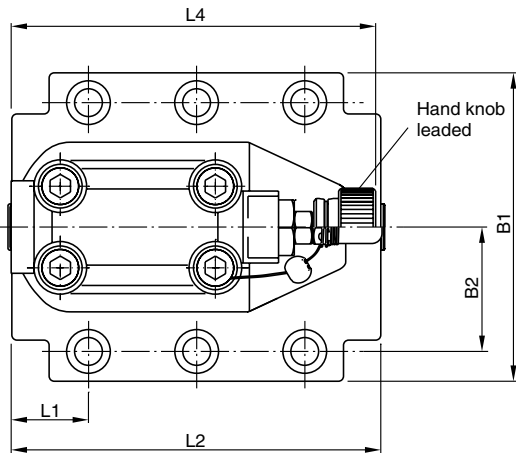



NG	ISO-code	x1	x2	x3	x4	x5	x6	x7	y1	y2	y3	y4	y5	y6
10	6264-06-07-*-97	42.9	35.8	21.5	–	7.2	21.5	0	66.7	58.8	33.4	7.9	14.3	–
25	6264-08-11-*-97	60.3	49.2	39.7	–	11.1	20.6	0	79.4	73	39.7	6.4	15.9	–
32	6264-10-15-*-97	84.2	67.5	59.5	42.1	16.7	24.6	0	96.8	92.8	48.4	3.8	21.4	–

Tolerance at X and Y pin holes and screw holes ±0.1, at port holes ±0.2.

NG	ISO-code	B1	B2	H1	H2	H3	H4	H5	H6	L1	L2	L4	L6
10	6264-06-07-*-97	87.3	33.35	83	21	–	–	62.5	–	25	90.8	143	144.8
25	6264-08-11-*-97	105	39.7	107.5	29	–	–	87	–	30.9	123	143	144.8
32	6264-10-15-*-97	120	48.4	120	30	–	–	99.5	–	29.8	143.5	143	144.8

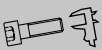
NG	ISO-code	d1max	d2max	d3	t3	d4	t4	d5	d6	Subplate ¹⁾
10	6264-06-07-*-97	15	7	7.1	8	M10	16	10.8	17	SPP 3M6B 910
25	6264-08-11-*-97	23.4	7.1	7.1	8	M10	18	10.8	17	SPP 6M8B 910
32	6264-10-15-*-97	32	7.1	7.1	8	M10	20	10.8	17	SPP 10M12B 910

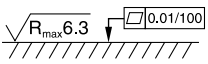
NG	Bolt kit			Kit		Surface finish
				NBR	FPM	
10	BK505	4x M10x35 ISO 4762-12.9	63 Nm ±15 %	S26-58507-0	S26-58507-5	
25	BK485	4x M10x45 ISO 4762-12.9	63 Nm ±15 %	S26-58475-0	S26-58475-5	
32	BK506	6x M10x45 ISO 4762-12.9	63 Nm ±15 %	S26-58508-0	S26-58508-5	

¹⁾ Details see chapter 12, series SPP.