

General Description

Series R4S pilot operated sequence valves enable a hydraulic system to operate in a pressure sequence. When the system pressure reaches the setting pressure the valve opens and permits flow to the secondary sub-system.

Features

- Pilot-operated sequence valve.
- 3 pressure ranges.
- 3 adjustment modes:
 - Hand knob
 - Acorn nut with lead seal
 - Key lock

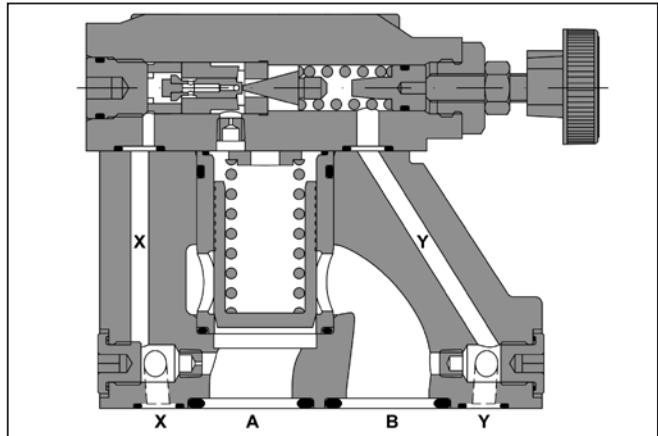
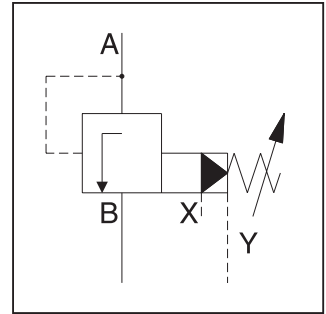

Ordering Information

<div style="border: 1px solid black; padding: 2px; width: 30px; margin: 0 auto;">R</div> <p>Pressure Valve</p>	<div style="border: 1px solid black; padding: 2px; width: 30px; margin: 0 auto;">4</div> <p>Interface</p>	<div style="border: 1px solid black; padding: 2px; width: 30px; margin: 0 auto;">S</div> <p>Relief Function</p>	<div style="border: 1px solid black; padding: 2px; width: 30px; margin: 0 auto;">5</div> <p>Maximum Pressure 350 Bar (5075 PSI)</p>	<div style="border: 1px solid black; padding: 2px; width: 30px; margin: 0 auto;">7</div> <p>Body Mounting</p>	<div style="border: 1px solid black; padding: 2px; width: 30px; margin: 0 auto;">1</div> <p>External Drain from Subplate</p>	<div style="border: 1px solid black; padding: 2px; width: 30px; margin: 0 auto;">A</div> <p>Design Series</p>	<div style="border: 1px solid black; padding: 2px; width: 30px; margin: 0 auto;">1</div> <p>Seal</p>																						
		<table border="1" style="width: 100%; border-collapse: collapse;"> <thead> <tr> <th style="text-align: left;">Code</th> <th style="text-align: left;">Description</th> </tr> </thead> <tbody> <tr> <td>03</td> <td>NG10</td> </tr> <tr> <td>06</td> <td>NG25</td> </tr> <tr> <td>10</td> <td>NG32</td> </tr> </tbody> </table>		Code	Description	03	NG10	06	NG25	10	NG32	<table border="1" style="width: 100%; border-collapse: collapse;"> <thead> <tr> <th style="text-align: left;">Code</th> <th style="text-align: left;">Description</th> </tr> </thead> <tbody> <tr> <td>1</td> <td>up to 105 Bar (1523 PSI)</td> </tr> <tr> <td>3</td> <td>up to 210 Bar (3045 PSI)</td> </tr> <tr> <td>5</td> <td>up to 350 Bar (5075 PSI)</td> </tr> </tbody> </table>		Code	Description	1	up to 105 Bar (1523 PSI)	3	up to 210 Bar (3045 PSI)	5	up to 350 Bar (5075 PSI)	<table border="1" style="width: 100%; border-collapse: collapse;"> <thead> <tr> <th style="text-align: left;">Code</th> <th style="text-align: left;">Description</th> </tr> </thead> <tbody> <tr> <td>1</td> <td>Nitrile</td> </tr> <tr> <td>5</td> <td>Fluorocarbon</td> </tr> </tbody> </table>		Code	Description	1	Nitrile	5	Fluorocarbon
Code	Description																												
03	NG10																												
06	NG25																												
10	NG32																												
Code	Description																												
1	up to 105 Bar (1523 PSI)																												
3	up to 210 Bar (3045 PSI)																												
5	up to 350 Bar (5075 PSI)																												
Code	Description																												
1	Nitrile																												
5	Fluorocarbon																												
<table border="1" style="width: 100%; border-collapse: collapse;"> <thead> <tr> <th style="text-align: left;">Code</th> <th style="text-align: left;">Interface</th> </tr> </thead> <tbody> <tr> <td>4</td> <td>Subplate Mounting ISO 5781</td> </tr> </tbody> </table> <div style="display: flex; justify-content: space-around; margin-top: 5px;"> <div style="text-align: center;"> <p>NG 10 and 25</p> </div> <div style="text-align: center;"> <p>NG 32</p> </div> </div>		Code	Interface	4	Subplate Mounting ISO 5781	<table border="1" style="width: 100%; border-collapse: collapse;"> <thead> <tr> <th style="text-align: left;">Code</th> <th style="text-align: left;">Description</th> </tr> </thead> <tbody> <tr> <td>1</td> <td>Hand Knob 32mm dia. Std.</td> </tr> <tr> <td>3</td> <td>Acorn Nut with Lead Seal</td> </tr> <tr> <td>4</td> <td>Key Lock</td> </tr> </tbody> </table>		Code	Description	1	Hand Knob 32mm dia. Std.	3	Acorn Nut with Lead Seal	4	Key Lock	<p>Weight:</p> <p>R4S03: 2.7 kg (6.0 lbs.)</p> <p>R4S06: 4.5 kg (9.0 lbs.)</p> <p>R4S10: 6.0 kg (13.2 lbs.)</p>													
Code	Interface																												
4	Subplate Mounting ISO 5781																												
Code	Description																												
1	Hand Knob 32mm dia. Std.																												
3	Acorn Nut with Lead Seal																												
4	Key Lock																												

Specifications

General			
Size	NG10	NG25	NG32
Interface	Subplate mounting acc. ISO 5781		
Mounting Position	As desired, horizontal mounting preferred		
Ambient Temperature	-20°C to +80°C (-4°F to +176°F)		
Hydraulic			
Operating Pressure	Ports A, B and X up to 350 Bar (5075 PSI), Port Y: depressurized		
Pressure Range	up to 105, 210, 350 Bar (1523, 3045, 5075 PSI)		
Nominal Flow	150 LPM (39.7 GPM)	350 LPM (92.6 GPM)	650 LPM (172.0 GPM)
Pressure Fluid	Hydraulic oil according to DIN 51524 ... 51525		
Viscosity Recommended Maximum	30 to 50 cSt / mm ² /s (139 to 232 SSU) 20 to 380 cSt / mm ² /s (93 to 1761 SSU)		
Pressure Fluid Temperature Recommended Maximum	+30°C to +50°C (+86°F to +122°F) -20°C to +70° (-4°F to +158°F)		
Filtration	ISO 4406 (1999), 18/16/13		

D

Performance Curves

Typical pressure curves at closing point

P1 = setting pressure

P2 = operating pressure

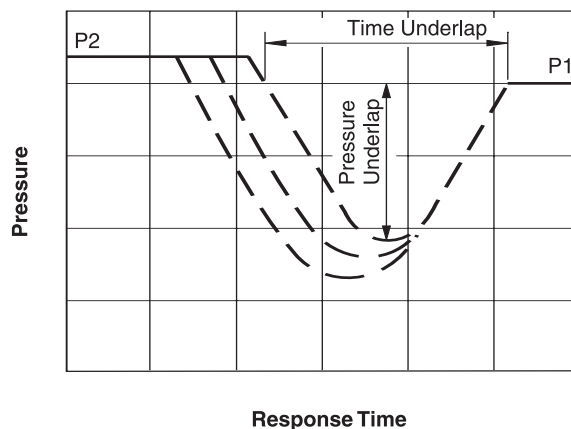

Note:

Time and pressure underlap depend on the characteristics of a specific system.

D

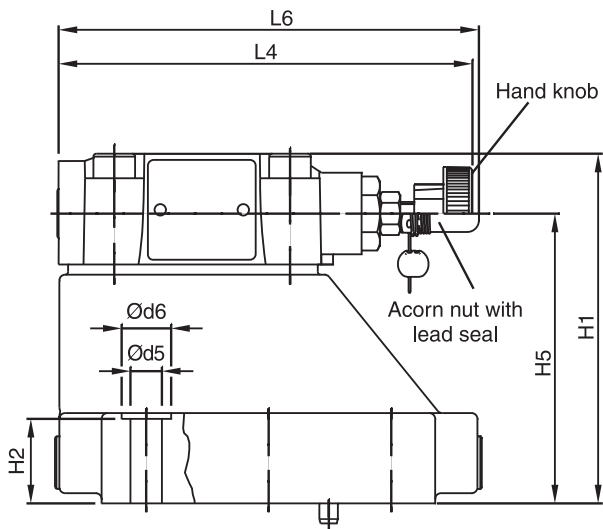
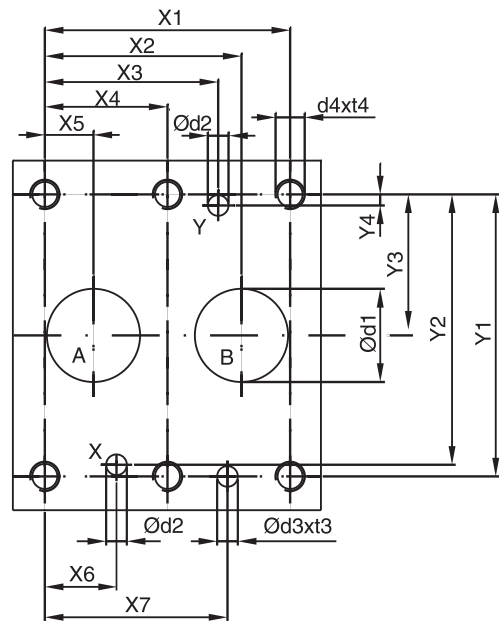
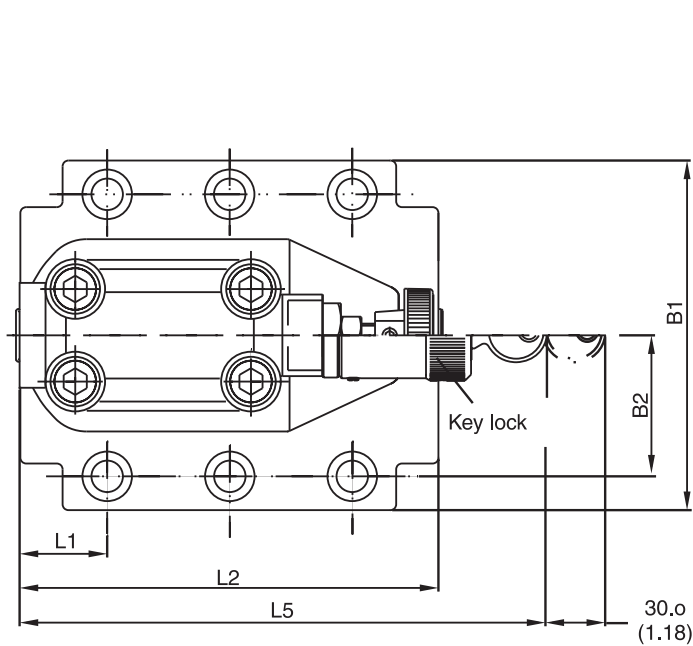



Inch equivalents for millimeter dimensions are shown in (**)

NG	ISO-code	x1	x2	x3	x4	x5	x6	x7	y1	y2	y3	y4	y5	y6
10	5781-06-07-0-00	42.9 (1.69)	35.8 (1.41)	21.5 (0.85)	–	7.2 (0.28)	21.5 (0.85)	31.8 (1.25)	66.7 (2.63)	58.8 (2.31)	33.4 (1.31)	7.9 (0.31)	–	–
25	5781-08-10-0-00	60.3 (2.37)	49.2 (1.94)	39.7 (1.56)	–	11.1 (0.44)	20.6 (0.81)	44.5 (1.75)	79.4 (3.13)	73.0 (2.87)	39.7 (1.56)	6.4 (0.25)	–	–
32	5781-10-13-0-00	84.2 (3.31)	67.5 (2.66)	59.5 (2.34)	42.1 (1.66)	16.7 (0.66)	24.6 (0.97)	62.7 (2.47)	96.8 (3.81)	92.8 (3.65)	48.4 (1.91)	3.8 (0.15)	–	–

Tolerance at X and Y pin holes and screw holes ±0.1, at port holes ±0.2.

NG	ISO-code	B1	B2	H1	H2	H3	H4	H5	H6	L1	L2	L3	L4	L5	L6
10	5781-06-07-0-00	87.3 (3.44)	33.4 (1.31)	83.0 (3.27)	21.0 (0.83)	62.5 (2.46)	–	–	–	29.0 (1.14)	94.8 (3.73)	–	141.0 (5.55)	181.0 (7.13)	–
25	5781-08-10-0-00	105.0 (4.13)	39.7 (1.56)	109.5 (4.31)	29.0 (1.14)	89.0 (3.50)	–	–	–	34.7 (1.37)	126.8 (4.99)	–	141.0 (5.55)	181.0 (7.13)	–
32	5781-10-13-0-00	120.0 (4.72)	48.4 (1.91)	120.0 (4.72)	29.0 (1.14)	99.5 (3.92)	–	–	–	30.6 (1.20)	144.3 (5.68)	–	141.0 (5.55)	181.0 (7.13)	–

NG	ISO-code	d1max	d2max	d3	t3	d4	t4	d5	d6
10	5781-06-07-0-00	15.0 (0.59)	7.0 (0.28)	7.1 (0.28)	8.0 (0.31)	M10	16.0 (0.63)	10.8 (0.43)	17.0 (0.67)
25	5781-08-10-0-00	23.4 (0.92)	7.1 (0.28)	7.1 (0.28)	8.0 (0.31)	M10	18.0 (0.71)	10.8 (0.43)	17.0 (0.67)
32	5781-10-13-0-00	32.0 (1.26)	7.1 (0.28)	7.1 (0.28)	8.0 (0.31)	M10	20.0 (0.79)	10.8 (0.43)	17.0 (0.67)

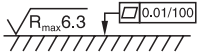
NG	ISO-code	Bolt Kit			Seal Nitrile	Kit Fluorocarbon	Surface Finish
10	5781-06-07-0-00	BK505	4xM10 x 35-DIN 912 12.9	63 Nm (46.5 lb.-ft.) ±15%	S26-58507-0	S26-58507-5	
25	5781-08-10-0-00	BK485	4xM10 x 45-DIN 912 12.9	63 Nm (46.5 lb.-ft.) ±15%	S26-58475-0	S26-58475-5	
32	5781-10-13-0-00	BK506	6xM10 x 45-DIN 912 12.9	63 Nm (46.5 lb.-ft.) ±15%	S26-58508-0	S26-58508-5	

NG	ISO-code	Subplate	Size
10	5781-06-07-0-00	SPP3M6B910	A, B = 3/4" BSPP x, y = 1/4" BSPP
25	5781-08-10-0-00	SPP6M8B910	A, B = 1" BSPP x, y = 1/4" BSPP
32	5781-10-13-0-00	SPP10M12B910	A, B = 1 1/2" BSPP x, y = 1/4" BSPP