



FOR MAXIMUM VALVE RELIABILITY, ADHERE TO THE FOLLOWING INSTALLATION INFORMATION.

The following is important installation information which applies to all directional control valves described in this catalog.

Mounting Position

- Detent – Horizontal
- Spring Offset – Unrestricted
- Spring Centered – Unrestricted

Fluid Recommendations

Premium quality hydraulic oil with a viscosity range between 32-54 cst. (150-250 SSU) At 38°C (100°F) is recommended. The absolute operating viscosity range is from 16-220 cst. (80-1000 SSU). Oil should have maximum anti-wear properties and rust and oxidation treatment.

Fluids and Seals

Valves using synthetic, fire-resistant fluids require special seals. When phosphate esters or its blends are used, FLUOROCARBON seals are required. Water-glycol, water-in-oil emulsions and petroleum oil may be used with STANDARD seals.

Filtration

For maximum valve and system component life, the system should be protected from contamination at a level not to exceed 125 particles greater than 10 microns per milliliter of fluid (SAE class 4/ISO 16/13).

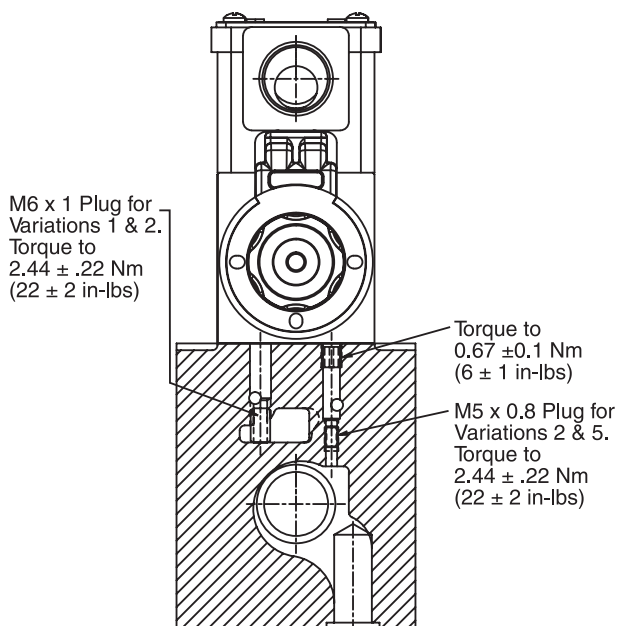

Silting

Silting can cause any sliding spool valve to stick and not spring return if held under pressure for long periods of time. The valve should be cycled periodically to prevent sticking.

Special Installations

Consult your Parker representative for any application requiring the following:

- Pressure above rating.
- Fluid other than those specified.
- Oil temperature above 71.1°C (160°F).
- Flow path other than normal.

Mounting Patterns

Series	NFPA	Size
D31V*, D3P	D05H, CETOP 5	3/8"
D31D*, D3DP, D31NW	D05HE, CETOP 5H	3/8"

Torque Specifications

The recommended torque values for the bolts which mount the valve to the manifold or subplate are as follows: 16.3 Nm (12 ft-lb).

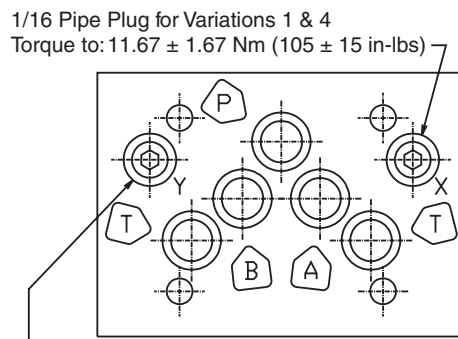

NFPA D05HE, CETOP 5H Pattern D31DW

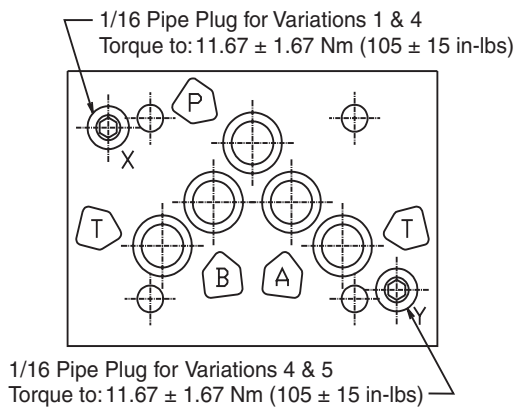

NFPA D05H, CETOP 5 Pattern D31VW



**SERIES D31*W, D31*A, D31*L
 PILOT OPERATED,
 DIRECTIONAL CONTROL VALVES**

Tank and Drain Line Surges

If several valves are piped with a common tank or drain line, flow surges in the line may cause an unexpected spool shift. No spring style valves are most susceptible to this. Separate tank and drain lines should be piped in installations where line surges are expected.

**Electrical Failure or
 Loss of Pilot Pressure (D31*A)**

Should electric power fail or loss of pilot pressure occur, spring offset and spring centered valves will shift to the spring held position. Detented valves will stay in the last position held before power failure. If main flow does not fail or stop at the same time power fails, machine actuators may continue to function in an undesirable manner or sequence.

**Electrical Characteristics
 (Detented Spool)**

Only a momentary energizing of the solenoid is necessary to shift and hold a detented spool. Minimum duration of the signal is 0.1 seconds for DC voltages. For AC voltages the response time is 0.06 seconds. Spool position will be held provided the spool centerline is in a horizontal plane, and no shock or vibration is present to displace the spool.

Pilot/Drain Characteristics

Pilot Pressure: 6.9 to 345 Bar (100 to 5000 PSI)

External: An oil source sufficient to maintain minimum pilot pressure must be connected to the “X” port of the main body. When using the external pilot variation, an M5 x 0.8 x 6mm long set screw must be present in the

main body pilot passage. (For details see Dimension pages.) This plug will be furnished in valves ordered with pilot code 2 or 5.

Internal: Flow is internally ported from the pressure port of the main valve body to the “P” port of the pilot valve. The pressure developed at the “P” port of the pilot valve must be 100 PSI (6.9 Bar) minimum at all times.

If the valve center condition allows flow from pressure to tank, 100 PSI (6.9 Bar) back pressure must be developed in the tank line to ensure sufficient pilot force at “P”. The “X” port in subplate must be plugged when using internal pilot variation (1/16 NPT).

Pilot Valve Drain:

Maximum pressure 102 Bar (1500 PSI), 207 Bar (3000 PSI) optional.

External: When using an external drain, an M6 x 1 x 10mm long set screw must be present in the main body drain passage. (For details see Dimension pages.) This plug will be furnished in valves ordered with drain code 1 or 2.

Drain flow from the pilot valve is at the “Y” port of the main body and must be piped directly to tank. Maximum drain line pressure is 102 Bar (1500 PSI), 207 Bar (3000 PSI) optional. Any drain line back pressure is additive to the pilot pressure requirement.

Internal: Drain flow from the pilot valve is internally connected to the main valve tank port. Tank and drain pressure are then identical so tank line pressure should not exceed 102 Bar (1500 PSI), 207 Bar (3000 PSI) optional. Any tank line back pressure is also additive to the pilot pressure requirement. If flow surges (a cause of pressure surges) are anticipated in the tank line, an external drain variation is recommended. The “Y” port in subplate must be plugged when using internal drain variations.

D31*W, D31*A, D31*L Flow Paths

Style Code	Description	No Solenoid/Operator Energized	Solenoid/Operator A Energized	Solenoid/Operator B Energized
B	Spring Offset	P→A and B→T	—	P→B and A→T
C	Spring Centered	Centered	P→A and B→T	P→B and A→T
D	Detented	Last Position Held	P→A and B→T	P→B and A→T
E	Spring Centered	Centered	—	P→B and A→T
F†	Spring Offset, Shift to Center	P→A and B→T	—	Centered
H	Spring Offset	P→B and A→T	P→A and B→T	—
K	Spring Centered	Centered	P→A and B→T	—
M†	Spring Offset, Shift to Center	P→B and A→T	Centered	—

† D31*W only.

D31.indd, dd





**SERIES D3P, D3DP PILOT OPERATED
 DIRECTIONAL CONTROL VALVES**

Tank and Drain Line Surges

If several valves are piped with a common tank or drain line, flow surges in the line may cause an unexpected spool shift. Separate tank and drain lines should be piped in installations where line surges are expected.

Loss of Pilot Pressure

Should oil pilot pressure fail, spring offset and spring centered valves will shift to the spring held position. Detented valves will stay in the last position held before power failure. If main flow does not fail or stop at the same time power fails, machine actuators may continue to function in an undesirable manner or sequence.

Mounting Pattern

D3P valves may be mounted on a standard D05 pattern subplate or manifold only if the “X” and “Y” ports are externally connected to the pilot block on top of the main body. All other mounting styles require a D05H or D05HE pattern which incorporates ports for the “X” and “Y” pilot and drain passages. Location of these ports can be found on the Recommended Mounting Surface pages in this section.

Pilot Drain Characteristics

Pilot Pressure: 6.9 to 345 Bar (100 to 5000 PSI)

Direct pilot operated valves use the “X” and “Y” ports to supply pilot oil directly to the ends of the spool, providing spool shifting force. A block mounted on top of the valve body is internally cored to make the necessary connections. Thus when “X” is pressurized, “Y” is used as a drain; and when “Y” is pressurized, “X” becomes the drain.

Any back pressure in these lines when they are being used as a drain is additive to the pilot pressure requirement.

Internal Drain: On spring offset models, only the “X” port is pressurized, as the spring returns the spool to its at rest position. On these models, “Y” may be internally drained through the main tank passage in the valve.

D3P Flow Path/Pilot Pressure

Style Code	Description	“X” & “Y” De-Pressurized	“X” Port Pressurized	“Y” Port Pressurized	Special Notes	Recommended Control Valve For Pilot Oil
B	Two Position Spring Offset	P→A, B→T	P→A, B→T	P→B, A→T	“X” Port may be pressurized to assist spring in returning spool to offset position (ext. only)	
C	Three Position Spring Centered	Center	P→A, B→T	P→B, A→T	Flow paths will be reversed on valves with tandem center (8) spools	
H	Two-Position Spring Offset	P→B, A→T	P→A, B→T	P→B, A→T	“Y” Port may be pressurized to assist spring in returning spool to offset position	

Series D31VW, D31VA, D31VL, D3P
Subplate Mounting
NFPA D05H, CETOP 5



Recommended Mounting Surface

Surface must be flat within .102 mm (0.0004 inch) T.I.R and smooth within 812.8 micro-meters (32 micro-inch). Torque bolts to 16.3 Nm (12 ft-lbs).

Mounting Position

Valve Type	Mounting Position
Detent (Solenoid)	Horizontal
Spring Offset	Unrestricted
Spring Centered	Unrestricted

For maximum valve reliability, adhere to the following installation information.

Mounting Pattern — NFPA D05H, CETOP 5

Inch equivalents for millimeter dimensions are shown in (**)

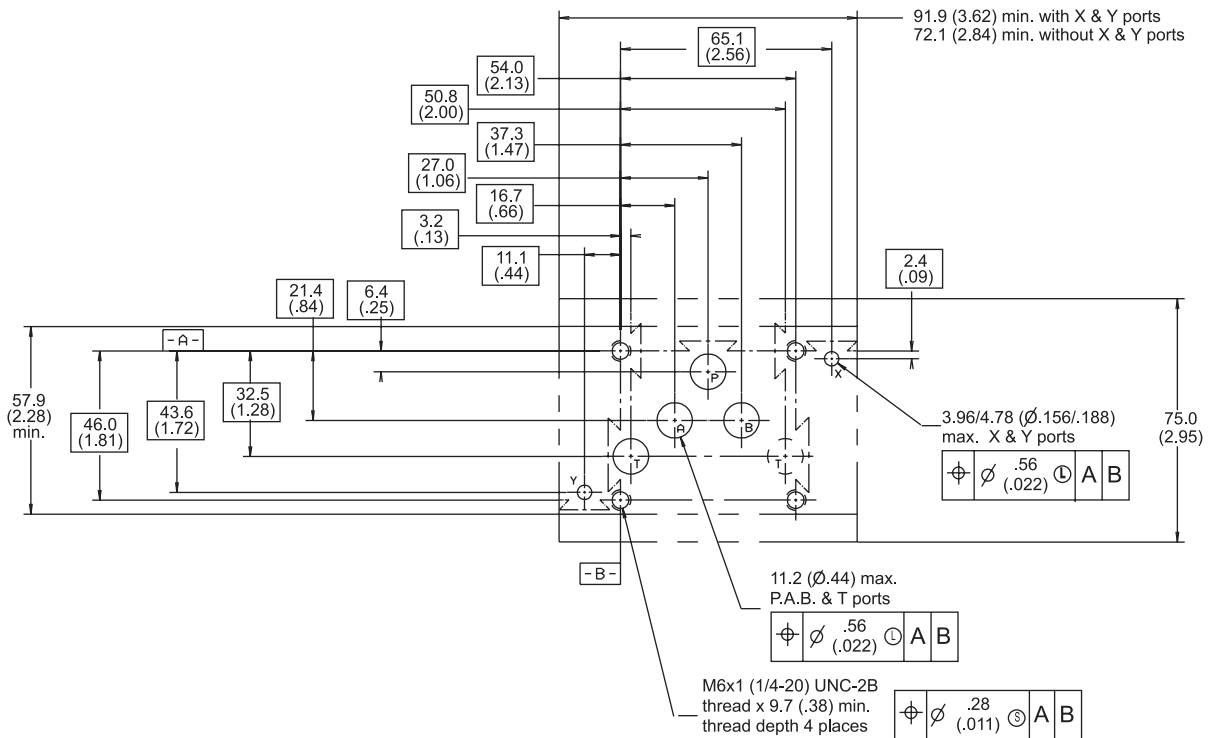

Series D31DW, D31DA, D31DL, D3DP, D31NW
Subplate Mounting
NFPA D05HE, CETOP 5H

A

Recommended Mounting Surface

Surface must be flat within .102 mm (0.0004 inch) T.I.R. and smooth within 812.8 micro-meters (32 micro-inch). Torque bolts to 16.3 Nm (12 ft-lbs).

Mounting Position

Valve Type	Mounting Position
Detent (Solenoid)	Horizontal
Spring Offset	Unrestricted
Spring Centered	Unrestricted

For maximum valve reliability, adhere to the following installation information.

Mounting Pattern — NFPA D05HE, CETOP 5H

Inch equivalents for millimeter dimensions are shown in (**)

