

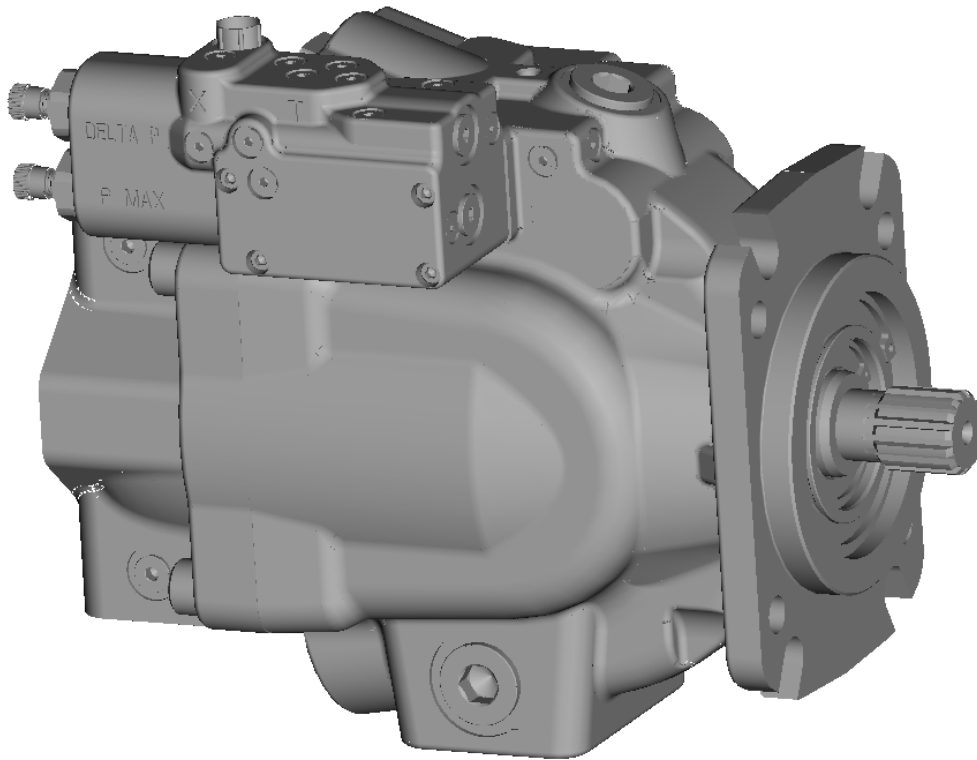

INSTALLATION MANUAL

SERIES P2

MOBILE PISTON PUMP



ECN 133814	RELEASE TO PR STATUS
ECN 134356	CHANGED TO REV. A

APPROVED BY M. KUEHNE	DATE 04NOV04	TITLE INSTALLATION MANUAL P2	SHEET 1 OF 6	
DRAWN BY J.LONGERICH	DATE 04NOV04	PART NO. P2-000-3921	REV. A	STATUS PR

1. Check model code / compare with your paper work

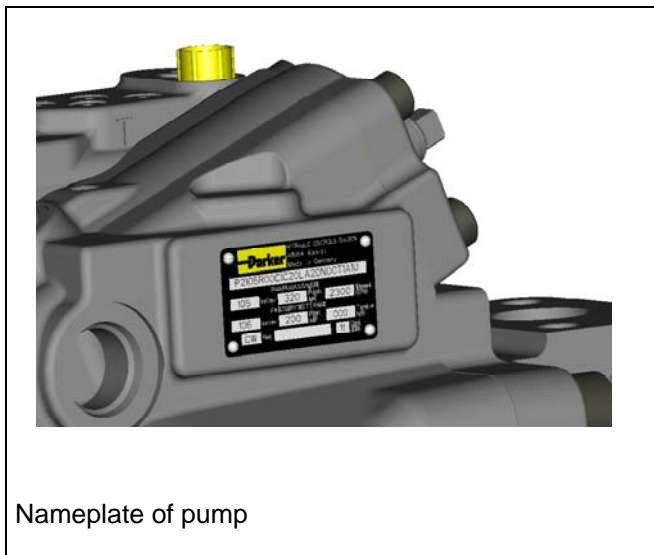

Nameplate of pump



Ordering / sales acknowledgement

2. Check rotation of pump

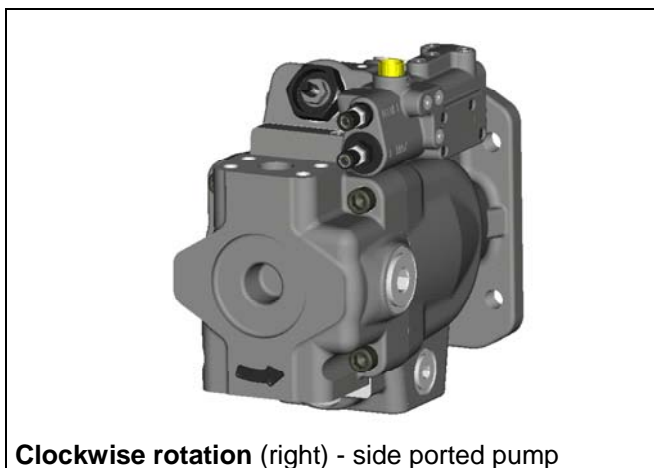

Clockwise rotation (right) - side ported pump

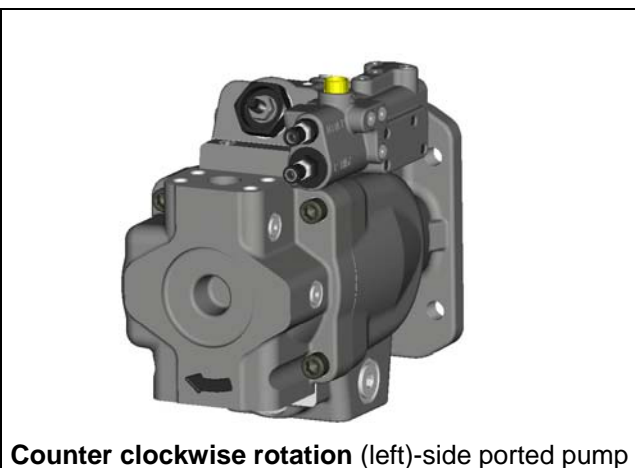

Counter clockwise rotation (left)-side ported pump

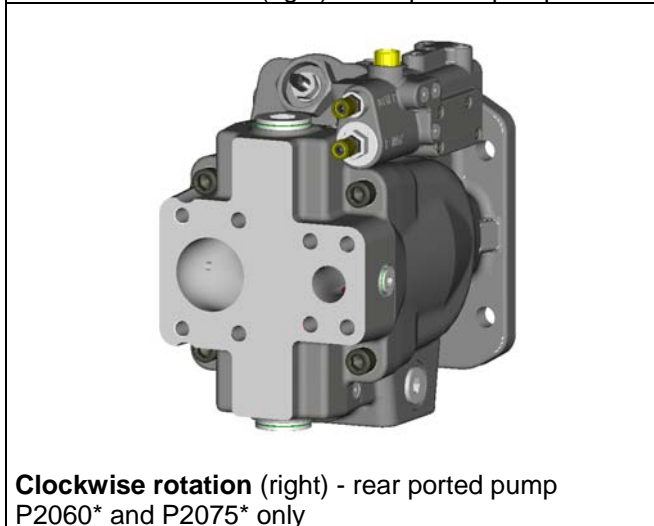

Clockwise rotation (right) - rear ported pump P2060* and P2075* only

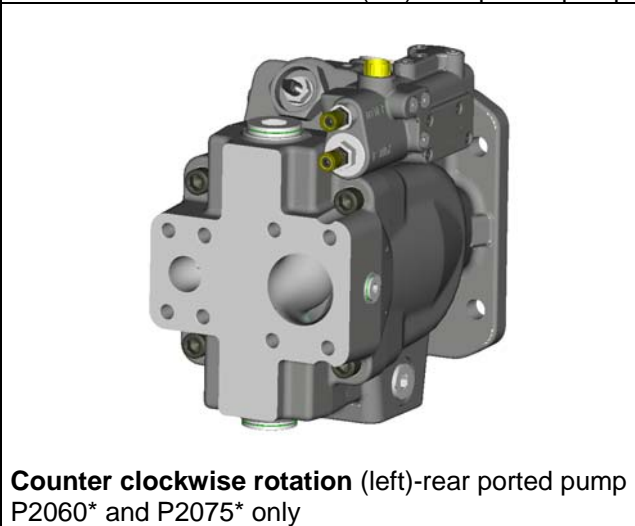

Counter clockwise rotation (left)-rear ported pump P2060* and P2075* only

APPROVED BY M. KUEHNE	DATE 04NOV04	TITLE INSTALLATION MANUAL P2	SHEET 2 OF 6	
DRAWN BY J.LONGERICH	DATE 04NOV04	PART NO. P2-000-3921	REV. A	STATUS PR

3. Suction, pressure and drain line connection

Minimum pump inlet pressure under static and dynamic load : $p_{in\ min} = 0,8\ \text{bar absolute}$

Maximum pump inlet pressure : $p_{in\ max} = 10\ \text{bar}$

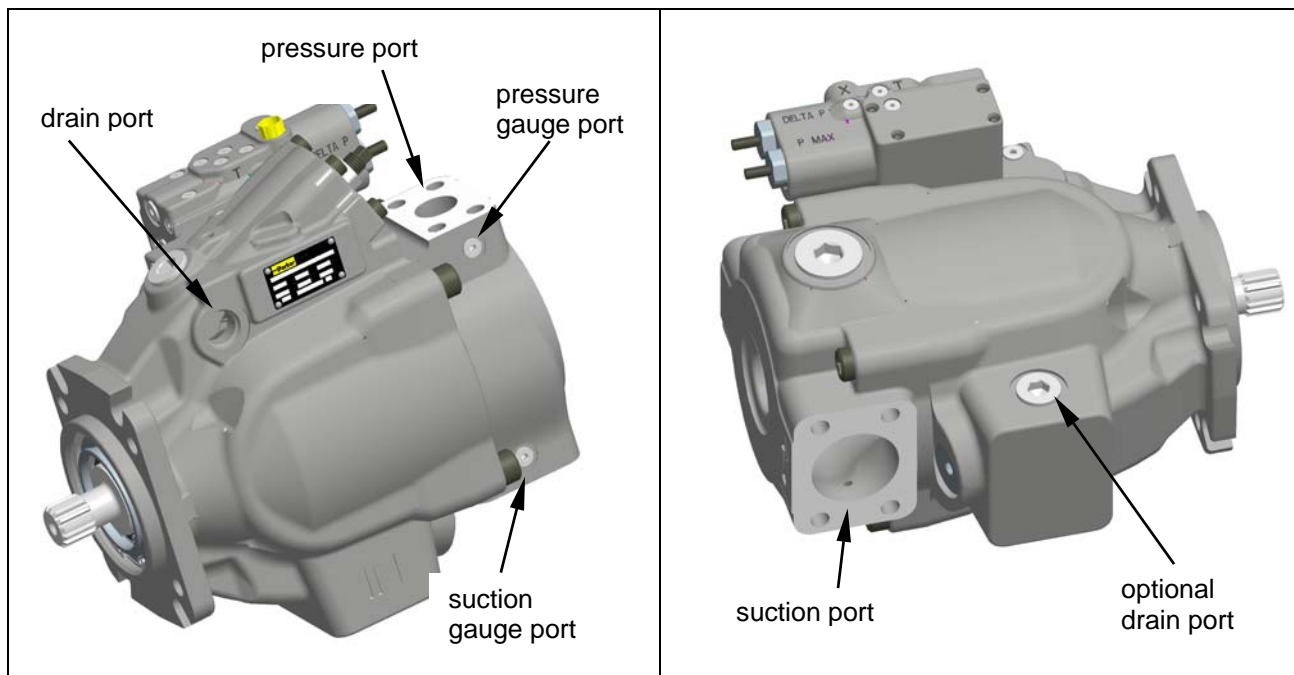

APPROVED BY M. KUEHNE	DATE 04NOV04	TITLE INSTALLATION MANUAL P2	SHEET 3 OF 6	
DRAWN BY J.LONGERICH	DATE 04NOV04	PART NO. P2-000-3921	REV. A	STATUS PR

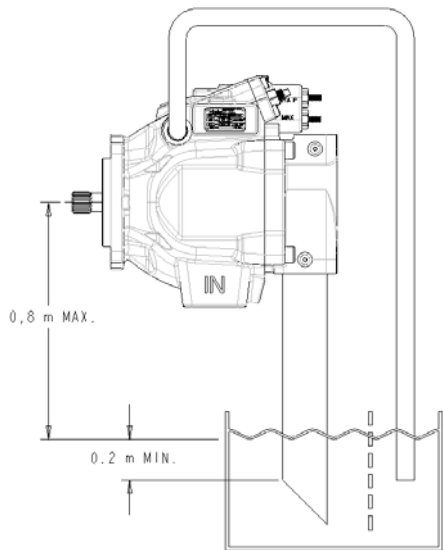

Arrangement outside tank.
 Fill pump case with oil before start.
 Do not restrict suction line.

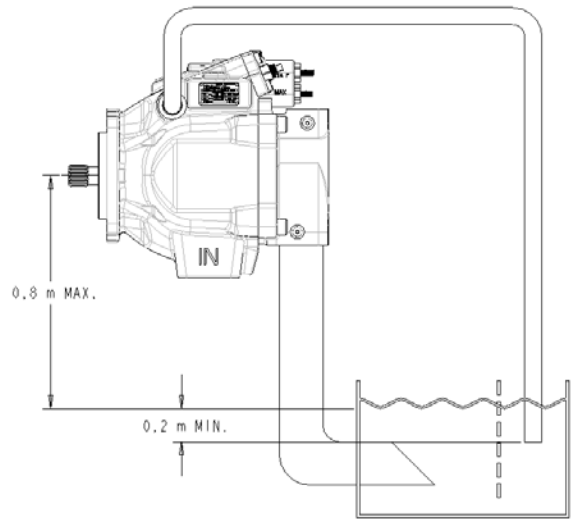

Arrangement outside tank.
 Fill pump case with oil before start.
 Do not restrict suction line.

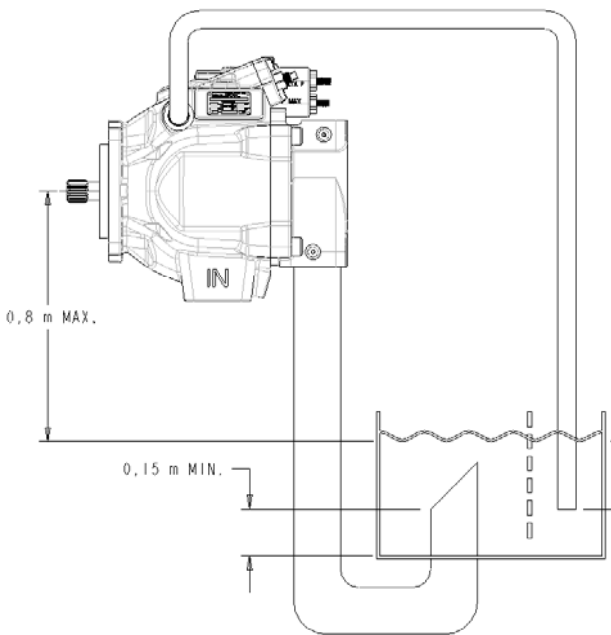

Arrangement outside tank.
 Fill pump case with oil before start.
 Do not restrict suction line.

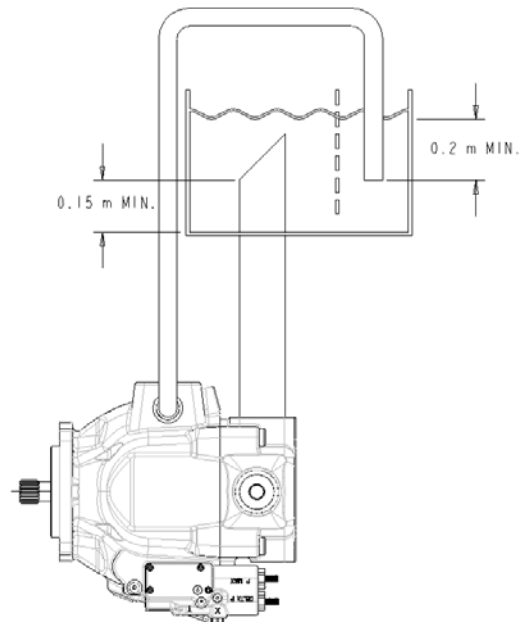

Arrangement outside tank.
 Fill pump case with oil before start.
 Do not restrict suction line.

Preferred arrangement for best suction characteristic and low noise level operation.

APPROVED BY M. KUEHNE	DATE 04NOV04	TITLE INSTALLATION MANUAL P2	SHEET 4 OF 6	
DRAWN BY J.LONGERICH	DATE 04NOV04	PART NO. P2-000-3921	REV. A	STATUS PR

4. Drain line connection

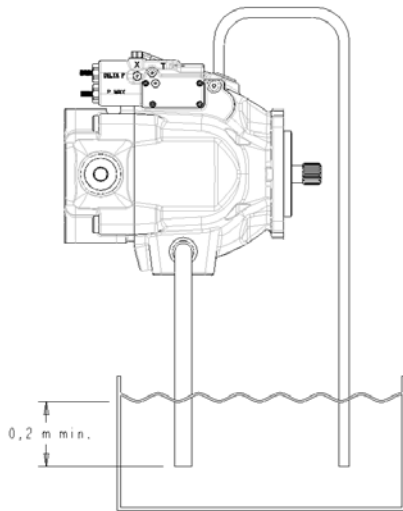

OPTION !

Connect highest drain port with a separate line reduced in size for purging the air out of the case

AND

secondary drain port has to be connected as main drain line.

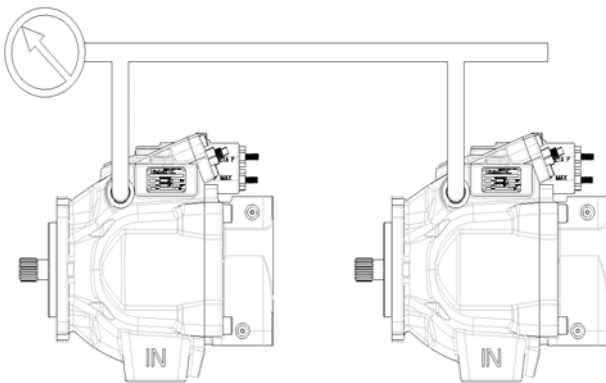

WARNING !

Do not combine drain lines.

Maximum continuous case pressure :

$$p_{\text{case}} = 0,5 \text{ bar}$$

Maximum intermittent peak case pressure :

$$p_{\text{case}} = 2 \text{ bar}$$

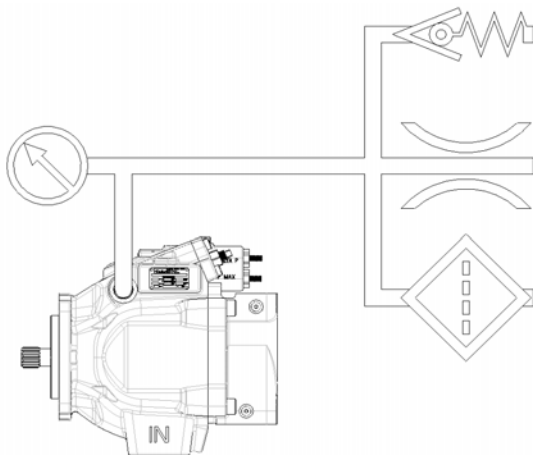

WARNING !

Do not restrict drain line.

A restricted drain line can damage the pump.

APPROVED BY M. KUEHNE	DATE 04NOV04	TITLE INSTALLATION MANUAL P2	SHEET 5 OF 6	
DRAWN BY J.LONGERICH	DATE 04NOV04	PART NO. P2-000-3921	REV. A	STATUS PR

5. Start up

Prior to start up, the pump case must be filled with hydraulic fluid (use case drain port). Initial start up should be at zero pressure with an open circuit to enable the pump to prime. Pressure should only be increased once the pump has been fully primed.

6. Hydraulic Fluid

6.1. Recommended fluids

- Normal mineral oil
- Premium hydraulic fluid / HLP oil
- Biodegradable hydraulic fluid
- Synthetic hydraulic fluid
- Fire resistant fluids

Remark :

Maximum system pressure reduced to 210 bar for water based fluids.
Bearing life time reduced to 25 % by using water based fluids.

6.2. Cleanliness level

Recommendation for maximized component life and reliability :

Class 21 / 18 / 14 according to ISO 4406

6.3. Viscosity range

Minimum viscosity for short periods : 10 mm²/s (cSt)

Normal operating viscosity : 15 cSt – 40 mm²/s (cSt)

Maximum viscosity for short periods : 1000 mm²/s (cSt)

7. Temperature

7.1. Check hydraulic fluid specification for chemical resistance of seal material !

7.2. Check temperature range of seal material
and compare with maximum system and ambient temperature !

N – Nitrile, single shaft seal **-40°C to +90°C**

D – Nitrile, double shaft seal **-40°C to +90°C**

V – Fluorocarbon, single shaft seal **-15°C to +150°C**

T – Fluorocarbon, double shaft seal **-15°C to +150°C**

Remark :

The highest fluid temperature will be at the drain port of the pump,
up to 20°C higher than in the reservoir.

APPROVED BY M. KUEHNE	DATE 04NOV04	TITLE INSTALLATION MANUAL P2	SHEET 6 OF 6	
DRAWN BY J.LONGERICH	DATE 04NOV04	PART NO. P2-000-3921	REV. A	STATUS PR