

HP2 Series variable displacement, closed loop dual piston pump

Features

Complete hydrostatic pumping system consisting of:

- Two independently controlled, variable displacement, over center piston pumps
- Single input drive shaft
- 2.5 quart integral reservoir
- Shock and/or check valves
- Integral filter
- Integral system cooling fan

Direct drive possible, eliminate belts, pulleys

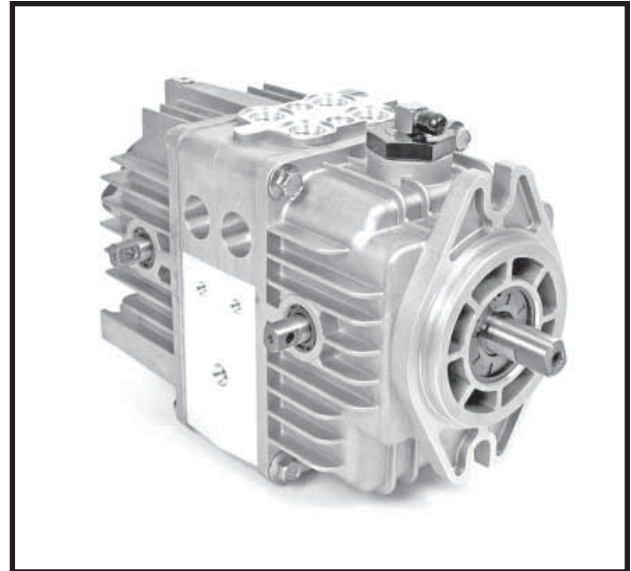

Schematic Symbol

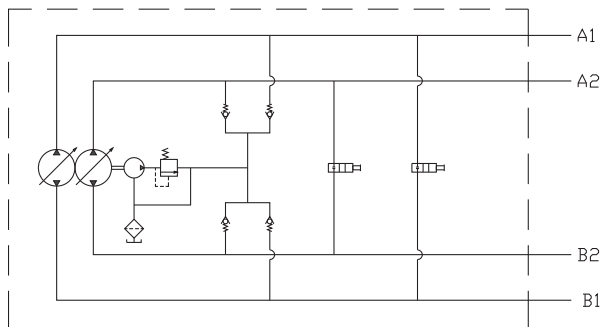

Specifications

SAE "B" Two Bolt Mounting Flange

Speed Range: 1800 - 3600 RPM

Weight: 15.4kg (34 lb) with oil

Fluid Viscosity: 9 cst (55 SUS) minimum

Fluid Filtration: 20 micron

Charge Pump Displacement:
3.2 cc (0.2 cu in/rev)

Operating Temperature Range:
-29°C to 104°C (-20°F to 220°F)

Quick Reference Data Sheet			
Displacement cc/rev (cu in/rev)	Continuous Rating bar (PSI)	Intermittent Rating bar (PSI)	Flow @ 3600 RPM 100 psi, max angle
11.5 (0.70)	90 (1300)	180 (2600)	41.3 lpm (10.9 GPM)
16.0 (0.98)	90 (1300)	180 (2600)	57.9 lpm (15.3 GPM)

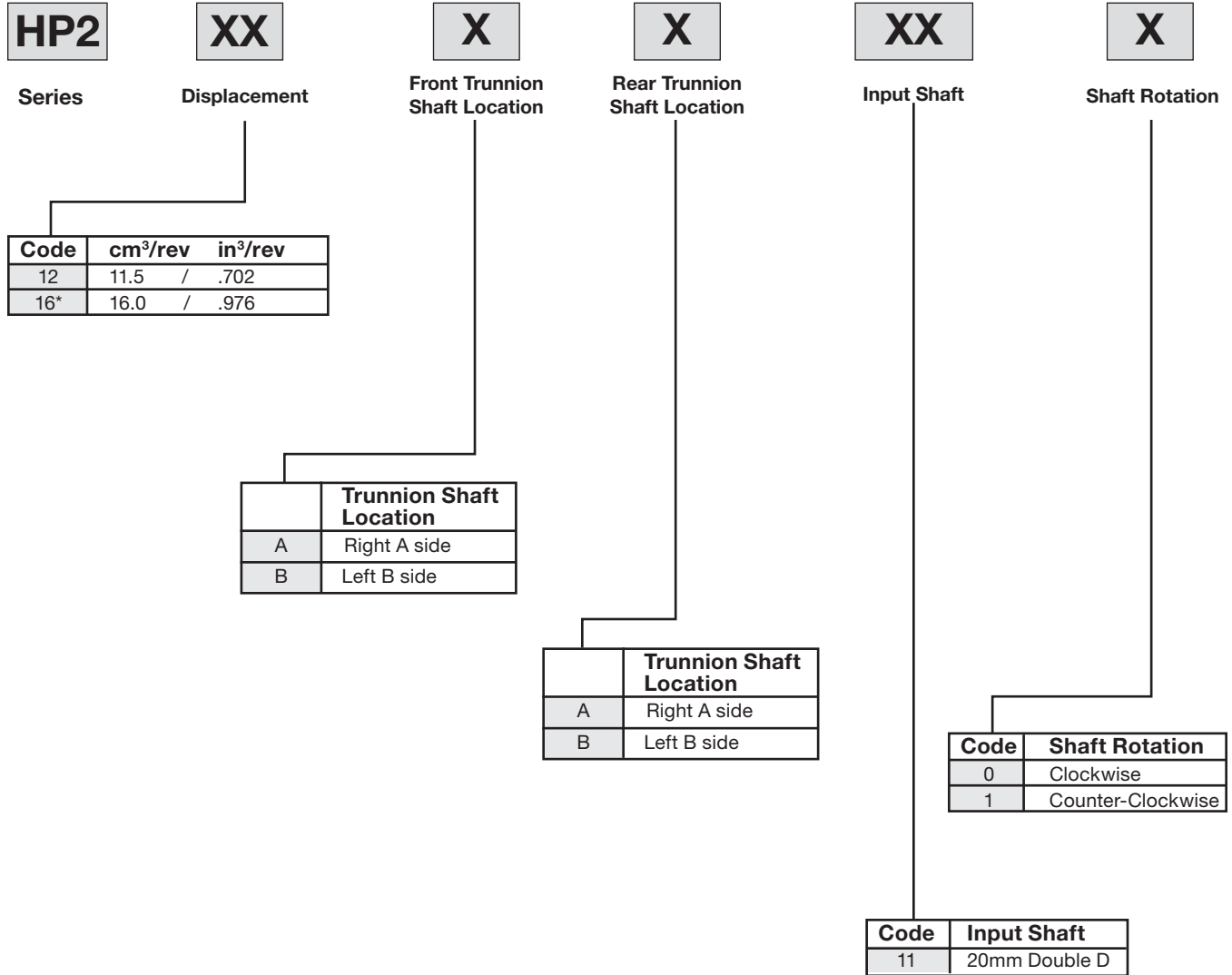

Note: Codes are based on pump orientation with "A" & "B" ports on top position as viewed from input shaft end. "Front" pump closest to input shaft end.

*Some sales restrictions apply to 16cc pump. Contact factory for information.

X

Front A Side Valve, Orifice

X

Front B Side Valve, Orifice

X

Rear A Side Valve, Orifice

X

Rear B Side Valve, Orifice

XXX

Options

A Side Code	Shock Valve/Orifice*	B Side Code
A	No Shock Valve or Orifice	A
B	Shock Valve, 210 bar, No Orifice	B
C	Shock Valve, 210 bar, .024" Orifice	C
D	Shock Valve, 210 bar, .031" Orifice	D
F	Shock Valve, 210 bar, .044" Orifice	F
G	No Shock Valve, .024" Orifice	G
H	No Shock Valve, .031" Orifice	H
J	No Shock Valve, .044" Orifice	J

A Side Code	Shock Valve/Orifice*	B Side Code
A	No Shock Valve or Orifice	A
B	Shock Valve, 210 bar, No Orifice	B
C	Shock Valve, 210 bar, .024" Orifice	C
D	Shock Valve, 210 bar, .031" Orifice	D
F	Shock Valve, 210 bar, .044" Orifice	F
G	No Shock Valve, .024" Orifice	G
H	No Shock Valve, .031" Orifice	H
J	No Shock Valve, .044" Orifice	J

Code	Option
AAD	Fan Towards Pump

*Consult factory for other available shafts/valving/options.

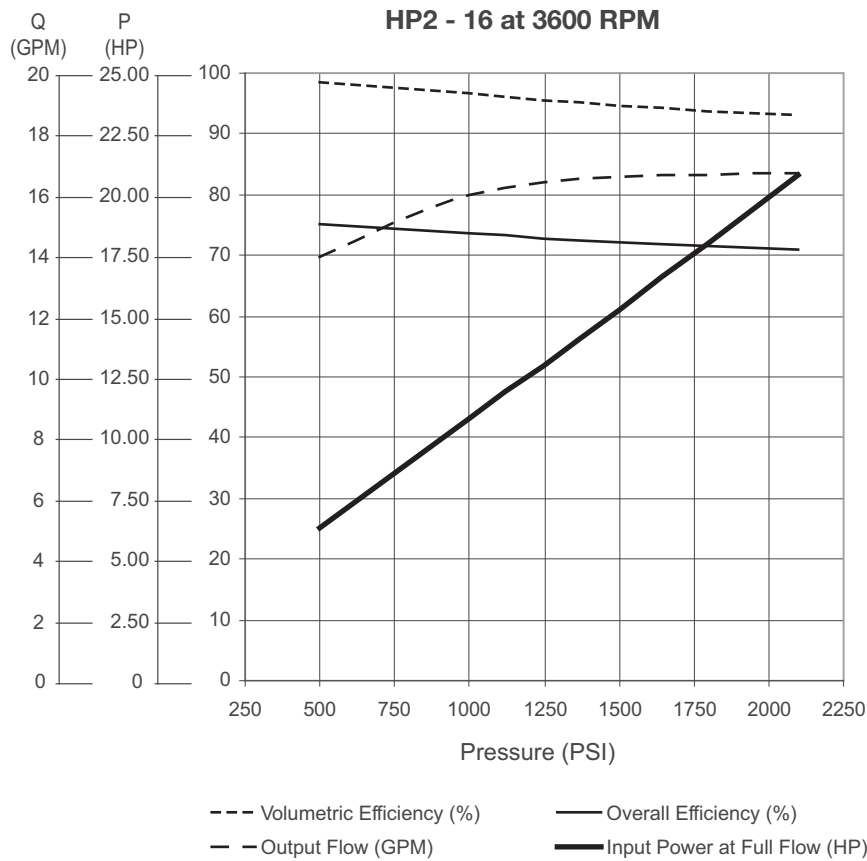
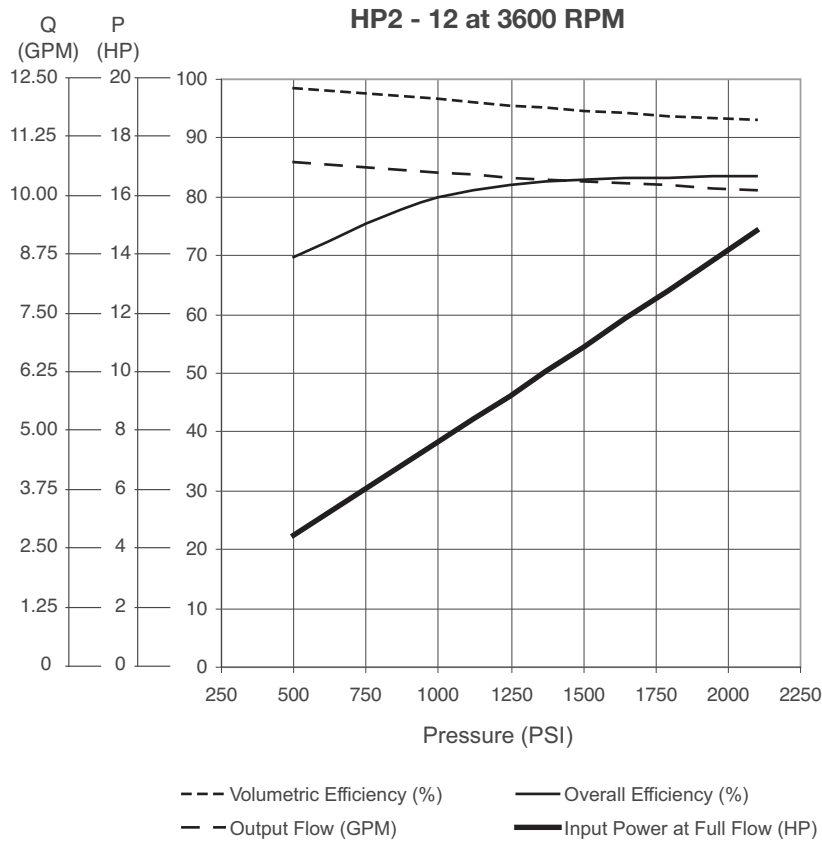

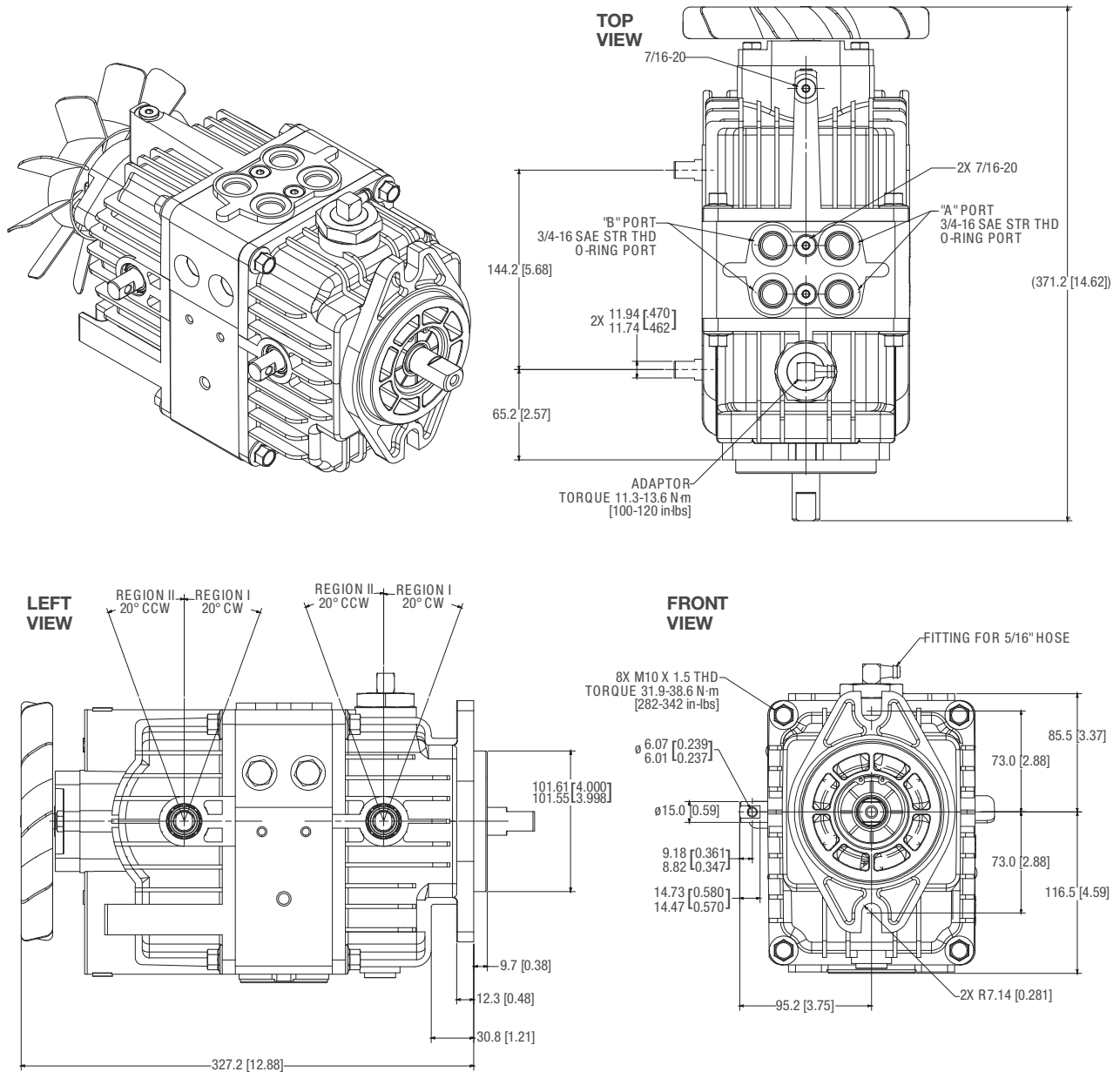

TRUNNION SHAFT LOCATION	RIGHT SIDE ("A" PORT SIDE)							
	CCW				CW			
INPUT SHAFT ROTATION	CCW				CW			
SECTION	Front		Rear		Front		Rear	
TRUNNION SHAFT ROTATION	REGION I	REGION II	REGION I	REGION I	REGION II	REGION II	REGION I	REGION II
DIRECTION	(CCW)	(CW)	(CCW)	(CCW)	(CW)	(CW)	(CCW)	(CW)
SYSTEM PORT "A" FLOW	IN	OUT	OUT	IN	OUT	IN	IN	OUT
SYSTEM PORT "B" FLOW	OUT	IN	IN	OUT	IN	OUT	OUT	IN

TRUNNION SHAFT LOCATION	LEFT SIDE ("B" PORT SIDE)							
	CCW				CW			
INPUT SHAFT ROTATION	CCW				CW			
SECTION	Front		Rear		Front		Rear	
TRUNNION SHAFT ROTATION	REGION I	REGION II	REGION I	REGION II	REGION I	REGION II	REGION I	REGION II
DIRECTION	(CCW)	(CW)	(CCW)	(CW)	(CCW)	(CW)	(CCW)	(CW)
SYSTEM PORT "A" FLOW	OUT	IN	IN	OUT	IN	OUT	OUT	IN
SYSTEM PORT "B" FLOW	IN	OUT	OUT	IN	OUT	IN	IN	OUT

