

# Media Isolated Solenoid Valves

## 1/4" NPT and 3/8" Barb Solenoid Valves



2-Way Media Isolated (or dry operator) valves are specially designed for non-contaminating and corrosive applications. The valves assure absolute purity and inertness to corrosion when used with a broad range of fluids.

### Product Features:

Media Isolated valves feature two basic construction innovations. The operator is physically isolated from the fluid by a diaphragm so only the seal and valve body come in contact with the fluid, and valve bodies of 303 Stainless Steel, PTFE, and Noryl™ provide the purity from contamination and resistance to corrosion that many industries demand.

### Typical Applications:

- Medical
- Life Science
- Dental
- Chemical Dispensing
- Instrumentation
- Food and Beverage



### Product Specifications

#### Mechanical

**Valve Type:**

2-Way Normally Closed (NC)

**Media:**

Liquids and gasses compatible with body material and seals.

**Wetted Materials:**

Body: PTFE, 303 SS, or Noryl  
Seals: PTFE or FKM

**Porting:**

1/4" NPT – PTFE & Stainless Body  
3/8" Barbs – Noryl Body

#### Performance

**Maximum Media Temperature:**

140°F (60°C)

**Maximum Ambient Temperature:**

150°F (65°C)

**Orifice Sizes / Cv / MOPD:**

5/64" / 0.16 / 70 psi  
5/32" / 0.35 / 35 psi  
3/16" / 0.47 / 20 psi

#### Electrical

**Voltage Options (Standard):**

120/60-110/50  
24 VDC

**Connections (Standard):**

DIN Form A  
1/4" Conduit (with 18" Leads)

**Temperature Class:**

F



ENGINEERING YOUR SUCCESS.

# Media Isolated Solenoid Valves

1/4" NPT and 3/8" Barb

## Standard Valve Part Numbers

Part Number Valve Ref	Coil	Voltage	Electrical Connection	Port Size	Orifice (in)	Factor (Cv)	Operating Pressure Differential (psi)		Watts AC/DC	Material	
							Min	Max		Body	Seal
71214LT3QV00	C111P3	120/60, 110/50	1/2" Conduit	3/8" Barb	5/32	0.35	0	35	10	Noryl	FKM
	C111C2	24 VDC	1/2" Conduit								
	D100P3	120/60, 110/50	DIN								
	D100C2	24 VDC	DIN								
71214LT3SV00	C111P3	120/60, 110/50	1/2" Conduit	3/8" Barb	3/16	0.47	0	20	10	Noryl	FKM
	C111C2	24 VDC	1/2" Conduit								
	D100P3	120/60, 110/50	DIN								
	D100C2	24 VDC	DIN								
71214TN2KT00	C111P3	120/60, 110/50	1/2" Conduit	1/4" NPT	5/64	0.16	0	70	10	PTFE	PTFE
	C111C2	24 VDC	1/2" Conduit								
	D100P3	120/60, 110/50	DIN								
	D100C2	24 VDC	DIN								
71214TN2ST00	C111P3	120/60, 110/50	1/2" Conduit	1/4" NPT	3/16	0.47	0	20	10	PTFE	PTFE
	C111C2	24 VDC	1/2" Conduit								
	D100P3	120/60, 110/50	DIN								
	D100C2	24 VDC	DIN								
71214VN2ST00	C111P3	120/60, 110/50	1/2" Conduit	1/4" NPT	3/16	0.47	0	20	10	303 SS	PTFE
	C111C2	24 VDC	1/2" Conduit								
	D100P3	120/60, 110/50	DIN								
	D100C2	24 VDC	DIN								

**Coil Housing** - Can be rotated 360°

**Spring provides positive plunger return**  
Permits valves to be mounted in any position.  
Preferred orientation is with the coil vertical and upright.

**Operator is isolated from media**  
Provides resistance to corrosion and eliminates possible contamination of media

**Molded glass filled Noryl plastic body**  
Provides strength and chemical inertness.  
PTFE is also available.

**Media is in contact with body material and diaphragm only**

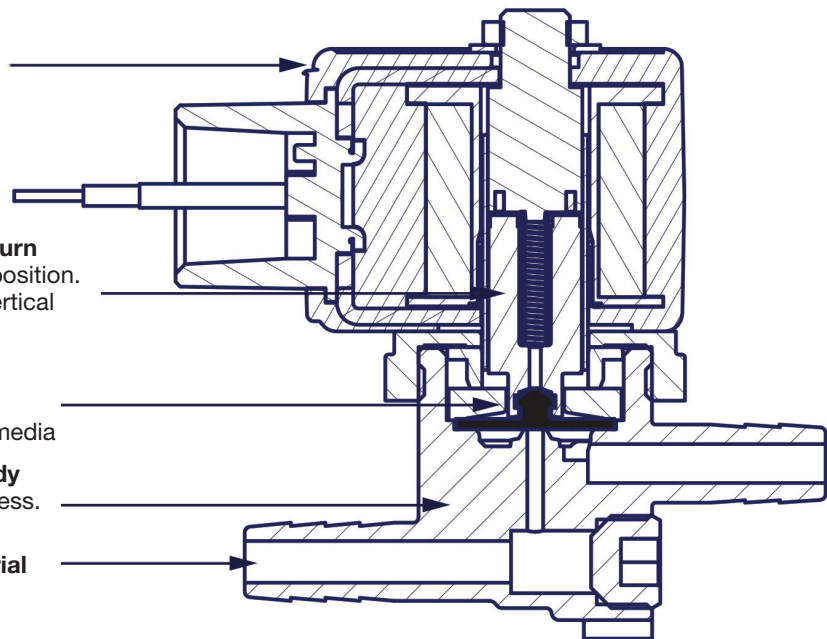

### Dimensions

**PTFE Body  
1/4" NPT**

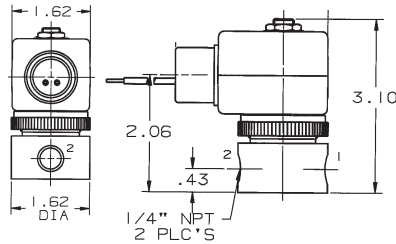

**303 SS Body  
1/4" NPT**

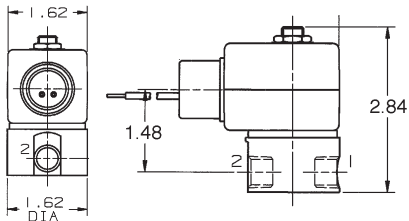

**Noryl Body  
3/8" Barb**

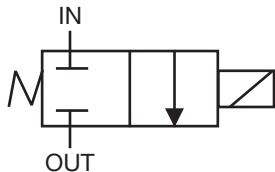
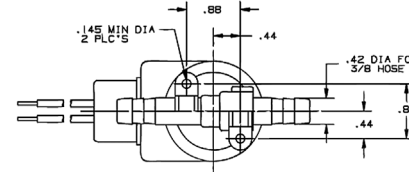
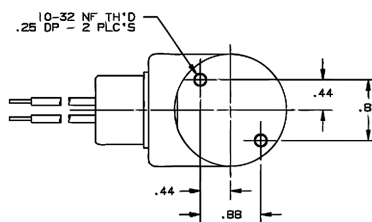
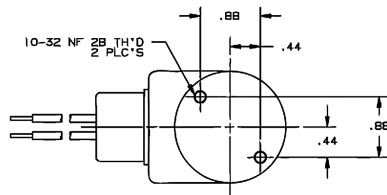
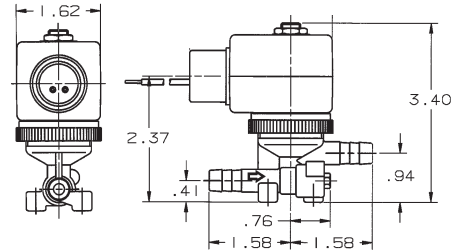

2-Way Normally Closed  
Port Identification: 1-OUT/2-IN

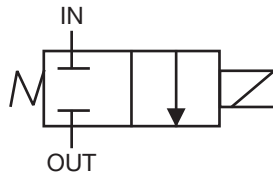

2-Way Normally Closed  
Port Identification: 1-OUT/2-IN

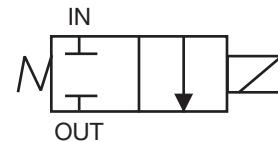

Flow arrow on body indicates flow direction. Ports are not marked.

### How to Order

1. Select Valve from listing above – based on ports, materials, and performance needs.
2. Select corresponding Coil from above – based on connector and voltage requirements.
3. Combine Valve Number + N0 + Coil Number – order complete part number.

**Example:** 3/8" Barb, 3/16 orifice, Noryl body, FKM Seal, DIN connector, 120/60.

71214LT3SV00 + N0 + D100P3 = 71214LT3SV00N0D100P3

## Accessories

### DIN - Cable Gland



ELECD1  
Gasket Included

### DIN - 1/2" Conduit



ELECD2  
Gasket Included

## Application Information

### Important Information On Back Pressure Data

Media Isolated valves require consideration of back pressure since the back pressure acts on a large area of the diaphragm. Excessive back pressure can keep the valves open on de-energization. The back pressure a standard valve can operate against depends on the orifice size, pressure differential and whether the media is a gas or liquid.

The following two charts provide a method to verify that the valve selected can meet the application back pressure requirements.

For applications involving back pressure that cannot be handled by catalog valves, please consult Parker Fluid Control Division.

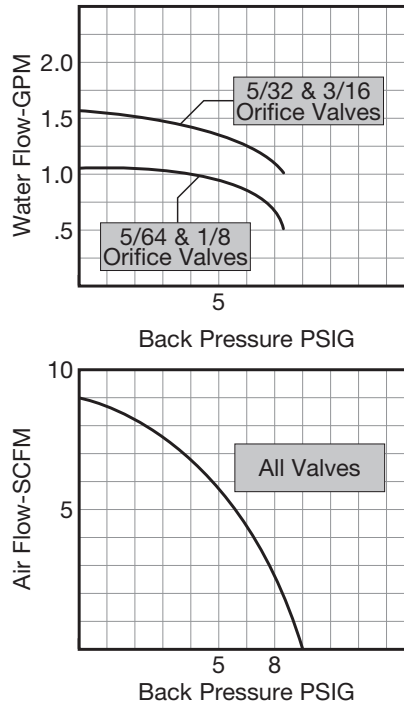

### Helpful Application Suggestions:

To keep the back pressure to a minimum, the downstream line should be as short as possible and be of the largest practical size. All restricting or flow controlling elements should be installed upstream.

### Use of Back Pressure Charts:

To use the charts, it is necessary to know the flow and back pressure.

1. First calculate the flow in GPM for liquids or SCFM for gases from the flow charts in the Technical Information Section.
2. The back pressure is the downstream pressure in the system. A catalog valve may be used if the intersection of flow and back pressure is below the curve for its orifice size.

