

Wiring diagram

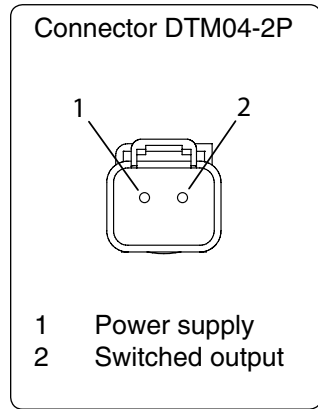

Notes:

1. Adjust sensor air gap. Distance is dependent on magnet target used.
2. Do not exceed specified torque limit, 0.8-1.2 Nm.
3. Do not mount switch directly on ferrous surfaces.
4. Recommended target approach is perpendicular to sensing surface.

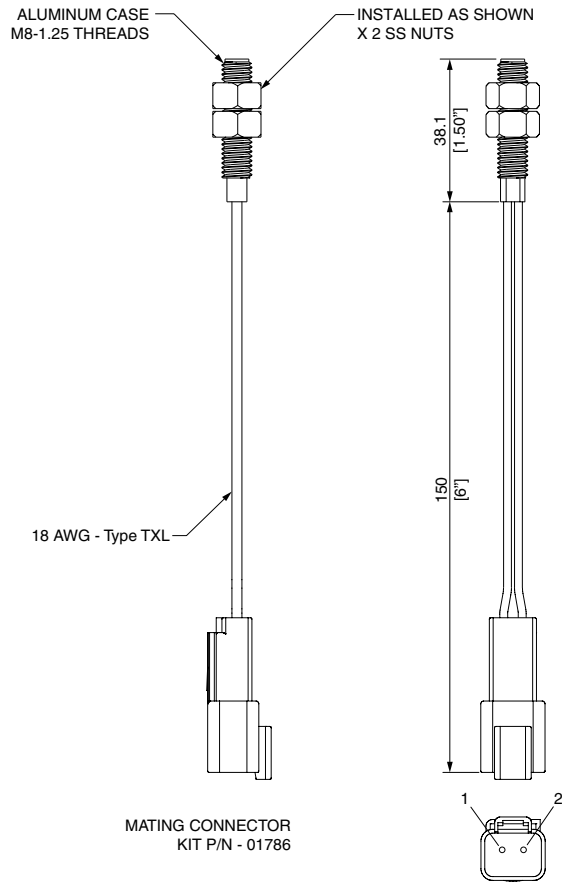

Complementary magnet target
Ordering P/N - 01143

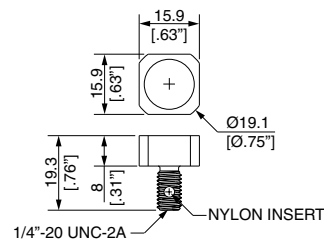
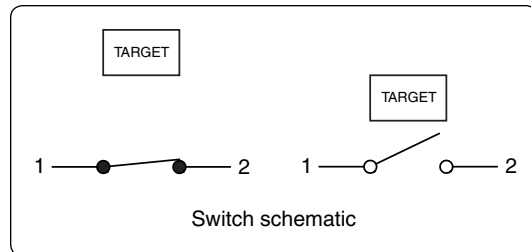

Installation PS65

Publ.no: HY33-2376-IS
Ed. 04/2013

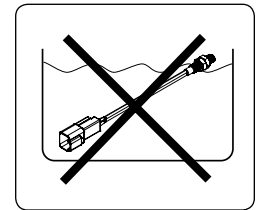
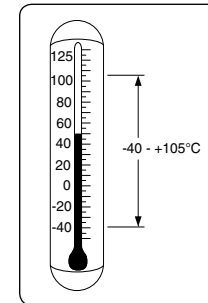
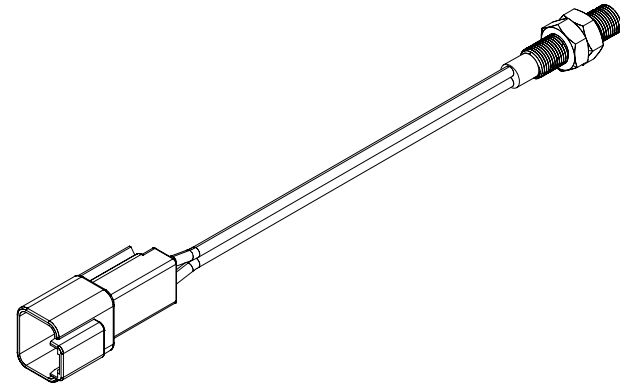

For further information see:
Catalog HY33-2376/US

WARNING

FAILURE OR IMPROPER SELECTION OR IMPROPER USE OF THE PRODUCTS AND/OR SYSTEMS DESCRIBED HEREIN OR RELATED ITEMS CAN CAUSE DEATH, PERSONAL INJURY AND PROPERTY DAMAGE.

This document and other information from Parker Hannifin Corporation, its subsidiaries and authorized distributors provide product and/or system options for further investigation by users having technical expertise. It is important that you analyze all aspects of your application, including consequences of any failure, and review the information concerning the product or system in the current product catalog. Due to the variety of operating conditions and applications for these products or systems, the user, through its own analysis and testing, is solely responsible for making the final selection of the products and systems and assuring that all performance, safety and warning requirements of the application are met.

The products described herein, including without limitation, product features, specifications, designs, availability and pricing, are subject to change by Parker Hannifin Corporation and its subsidiaries at any time without notice.

