

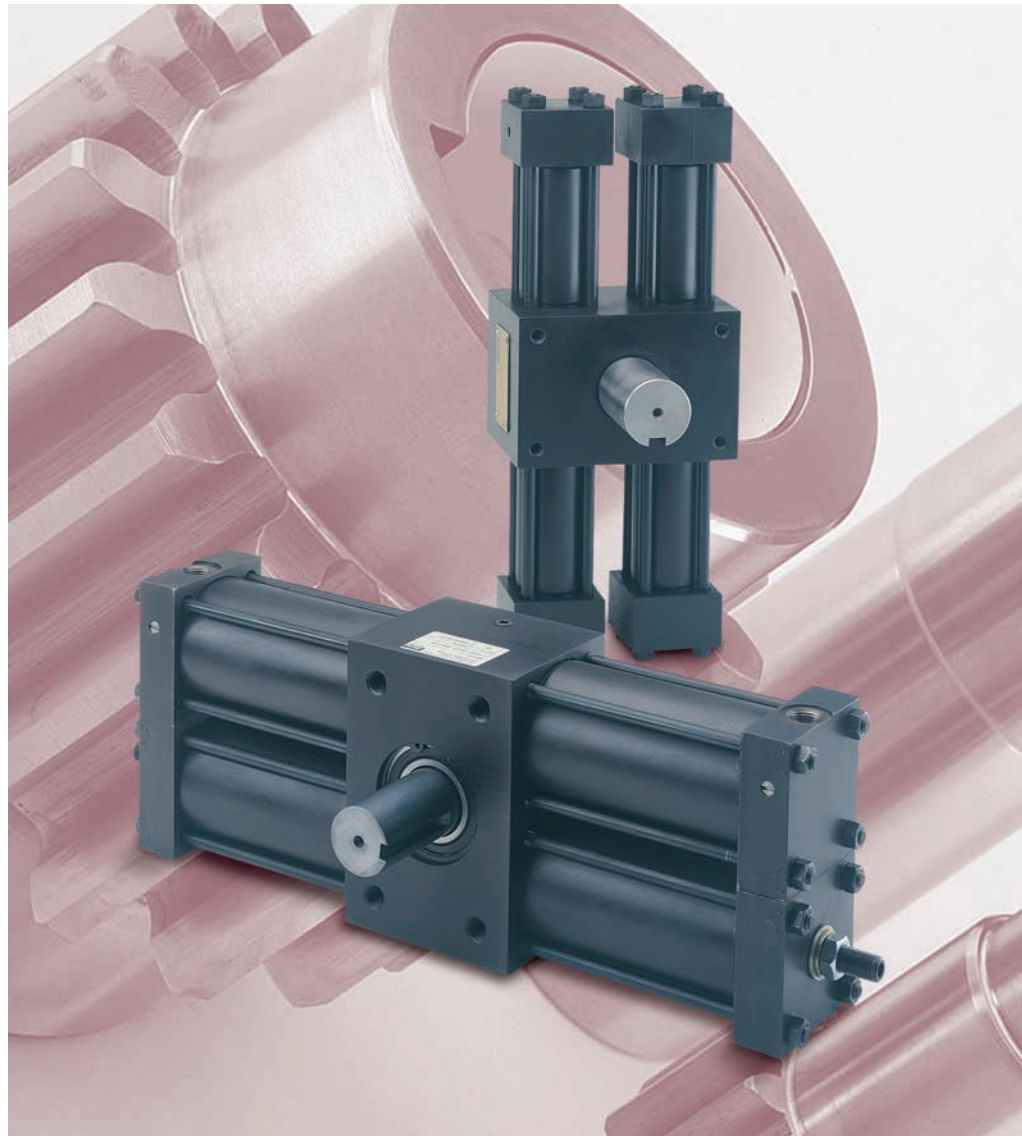

# ***HTR Hydraulic Rotary Actuators***

*For working pressures up to 210 bar*

*Catalogue HY07-1220/UK  
November 2002*



**HTR Rotary Actuators**

HTR Series heavy duty hydraulic rack and pinion rotary actuators convert fluid power into rotary motion. They are suitable for a wide variety of applications, including material handling and valve actuation, in industries as diverse as machine tools, primary metals, mining and oil field equipment.

HTR Series rotary actuators are designed for slow speed rotation, applying high torque to the movement of large masses. They employ conventional tie rod cylinder construction and are rated for use at working pressures up to 210 bar. The pinion and output shaft are supported in large tapered roller bearings, allowing the unit to support high external and thrust loads. All HTR Series rotary actuators feature a high strength, ductile iron housing, for ease of mounting and good shock resistance.

In addition to the standard HTR Series rotary actuators described in this catalogue, special designs can be produced to suit customer requirements. Our engineers will be pleased to advise on unique designs to meet specific applications.

**Contents**

	<b>Page</b>
Design Features and Benefits	3
General Specifications	4
Shaft Options	5
Dimensions	6
Mounting Styles	8
Port Sizes and Positions	8
Air Bleeds	8
Cushioning	9
Piston Seals	11
Seal Kits	11
Filtration	11
Stroke Limiters	11
Bearing Load Capacities	12
Position Switches	13
Feedback Devices	14
Ordering Information	15
Maintenance and Spare Parts	15

**Why use a Rotary Actuator?**

- provides uniform torque in both directions
- simple, compact design
- wide range of sizes
- high torque output from a small envelope
- no external linkage needed for rotary motion
- excellent holding capability
- rotation can be specified to suit application
- will support radial and thrust loads

**Specifications**

- Max. non-shock operating pressure 210 bar
- Design pressure 315 bar
- Rotational range Standard – 90°, 180°, 360°  
Special order – any rotation to a maximum of 1800°
- Rotational tolerance -0°, +2°
- Output torque at 210 bar 100 – 68000Nm
- Min. operating pressure 5 bar
- Max. angular backlash –
 

HTR.9 – HTR10	30 minutes
HTR15 – HTR150	15 minutes
HTR300 – HTR600	10 minutes
- Self-energizing, wear-compensating polyurethane piston seals

**About Parker Hannifin**

Parker Hannifin is the global leader in motion and control technologies, partnering with its customers to increase their productivity and profitability. The company employs more than 57,000 people in 43 countries around the world, providing customers with technical excellence and first class customer service.

In addition to the HTR Series of rotary actuators featured in this catalogue, Parker also manufactures a wide range of other hydraulic and electro-hydraulic actuator products. Catalogues describing our standard products are available on request from your nearest Parker sales office – see rear cover for addresses.

**Visit us at [www.parker.com/eu](http://www.parker.com/eu)**

**Warning**

FAILURE OR IMPROPER SELECTION OR IMPROPER USE OF THE PRODUCTS AND/OR SYSTEMS DESCRIBED HEREIN OR RELATED ITEMS CAN CAUSE DEATH, PERSONAL INJURY AND PROPERTY DAMAGE.

This document and other information from Parker Hannifin Corporation, its subsidiaries, sales offices and authorized distributors provide product or system options for further investigation by users having technical expertise. Before you select or use any product or system it is important that you analyse all aspects of your application and review the information concerning the product or system in the current product catalogue. Due to the variety of operating conditions and applications for these products or systems, the user, through his own analysis and testing, is solely responsible for making the final selection of the products and systems and assuring that all performance and safety requirements of the application are met.

The products described herein, including without limitation, product features, specifications, designs, availability and pricing, are subject to change by Parker Hannifin Corporation and its subsidiaries at any time without notice.

**Offer of Sale**

Please contact you local Parker representative for a detailed offer of sale.

**1 Rack and Pinion**

Maximum strength and shock resistance result from the use of through-hardened chrome alloy steel for the rack and for the one-piece pinion and output shaft. Gears are packed with molybdenum disulphide grease on assembly, to reduce wear and prolong gear life under conditions of extreme pressure.

**2 Bronze Rack Bearings**

Generous support for the rack is provided by a bronze rack bearing, reducing wear and extending pinion life. The bronze rack bearing, a standard feature on HTR15 models and above, is available as an option on smaller units.

**3 Gear Housing**

High strength ductile iron provides resistance to shock loads under the most arduous operating conditions. Four mounting holes in both the front and rear faces permit flexibility in machine design, with base and pilot mounting styles available as options.

**6 Tie Rod Cylinders**

Proven tie rod construction, using standard cylinder bore sizes, guarantees reliability and ease of maintenance for the hydraulic cylinders which drive the rack and pinion. Heavy-walled alloy steel tubing is micro-finished for long piston and seal life, while tie rods are drawn from alloy steel, with precision rolled threads for high strength and resistance to fatigue.

**7 Pistons and Seals**

Rugged one-piece steel pistons (not HTR.9 or HTR1.8) are fitted as standard with polyurethane seals and PTFE wear rings, preventing metal-to-metal contact. The piston seals are self-compensating for long life and reduced maintenance and, subject to access, seals and wear rings can be inspected or replaced without removing the actuator from the machine.

**8 Cushioning**

Progressive deceleration is available by specifying cushions for either or both directions of rotation. The self-centring cushions are adjustable, permitting exact matching to load and speed conditions, and offer extended machine life with reduced noise and shock.

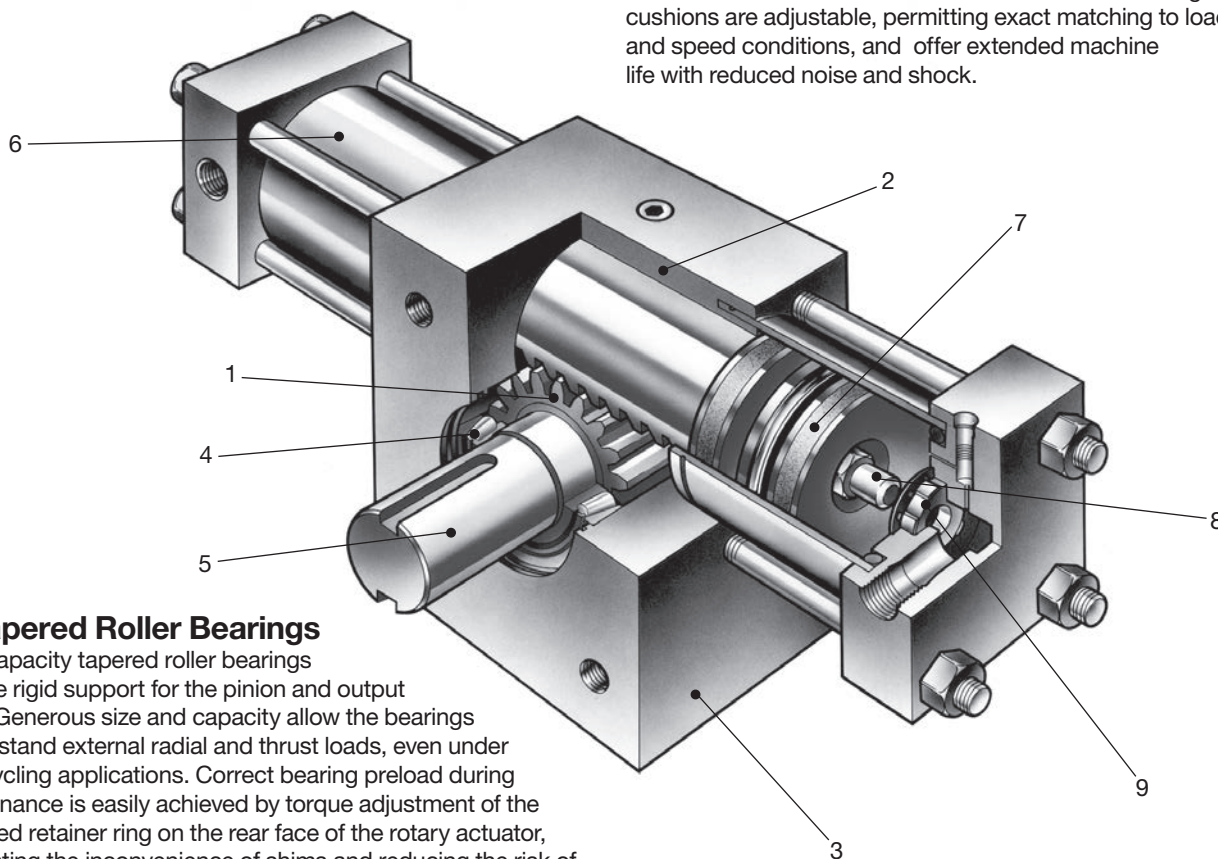

**4 Tapered Roller Bearings**

High capacity tapered roller bearings provide rigid support for the pinion and output shaft. Generous size and capacity allow the bearings to withstand external radial and thrust loads, even under high cycling applications. Correct bearing preload during maintenance is easily achieved by torque adjustment of the threaded retainer ring on the rear face of the rotary actuator, eliminating the inconvenience of shims and reducing the risk of damage to the bearing through incorrect adjustment.

**5 Shaft Options**

A plain male shaft with two keyways, the most widely used style of shaft, is supplied as standard with all HTR Series rotary actuators. The keyways are set at the 12- and 6-o'clock positions at mid-stroke for ease of positioning and assembly, and are as large as possible to ensure maximum strength. Shaft options include a female shaft with two keyways, and male and female splined types. Both single and double shaft options are available, providing the greatest possible flexibility for the machine designer.

**9 Floating Cushion Bushes**

Closer tolerances – and therefore more effective cushioning – are permitted by the use of floating cushion bushes. Lifting of the bronze cushion bush minimises fluid restriction to the start of the return stroke, allowing full pressure to be applied over the whole area of the piston, to provide full power and rapid cycle times.

**Advantages of Parker's  
Rack and Pinion Rotary Actuators**

- Cost-effectiveness – especially above 90°, where linear actuators need increasingly intricate linkages to generate rotary motion.
- Simplicity – a rotary actuator with a hollow, or female, shaft can replace support bearings and pillow blocks, due to the high load capacity of the bearings.
- Resistance to hostile environments – no extending/retracting sealing surfaces exposed to abrasive or corrosive substances. Special materials and coatings ensure long life in arduous usage.
- Ease of maintenance – servicing of pistons and seals can be carried out with the actuator in place on the machine, subject to access.
- Leakage resistance – pressurized fluid is remote from the output side of the mechanism; piston seals are the only dynamic seals subject to system pressure.
- Long life – the rack/pinion/bearing assembly is packed with molybdenum grease on assembly and does not come into contact with hydraulic fluid.
- Premium quality – every Parker rotary actuator is proof tested before shipping.

**General Specification – Volumes**

Model		cm <sup>3</sup> per degree	cm <sup>3</sup> per radian	Displacement – cm <sup>3</sup>		
Single Rack	Double Rack			90° Rotation	180° Rotation	360° Rotation
HTR.9		0.1	6	9	19	37
	HTR1.8	0.2	12	19	37	74
HTR3.7		0.4	25	40	80	159
	HTR7.5	0.9	51	79	159	318
HTR5		0.6	33	51	102	205
	HTR10	1.1	65	102	205	410
HTR15		1.6	93	145	291	582
	HTR30	3.2	185	291	582	1164
HTR22		2.5	145	227	455	910
	HTR45	5.1	290	455	910	1819
HTR75		8.4	480	754	1508	3016
	HTR150	17	960	1508	3016	6032
HTR300		32	1855	2913	5827	11653
	HTR600	65	3707	5823	11645	23290

**General Specification – Torque Outputs, Pressure Ratings and Weights**

Model		Continuous Duty <sup>1</sup>		Intermittent Duty <sup>2</sup>		Static Duty <sup>3</sup>		Weights – kg		
Single Rack	Double Rack	Torque Nm	Pressure bar	Torque Nm	Pressure bar	Torque Nm	Pressure bar	90° Rotation	180° Rotation	360° Rotation
HTR.9		80	160	100	210	100	210	5	6	9
	HTR1.8	160	160	200	210	200	210	7	9	11
HTR3.7		260	125	390	190	420	210	13	14	17
	HTR7.5	540	130	800	200	850	210	16	19	24
HTR5		330	120	495	180	565	210	17	18	22
	HTR10	700	130	1000	190	1130	210	20	25	30
HTR15		960	115	1440	175	1700	210	25	27	32
	HTR30	2000	120	3000	190	3400	210	40	44	53
HTR22		960	80	1440	115	1700	140	27	30	36
	HTR45	2000	80	3000	120	3400	140	45	49	61
HTR75		4500	110	6750	165	8500	210	90	100	120
	HTR150	9500	115	14200	170	17000	210	146	167	206
HTR300		13000	80	19500	120	34000	210	345	382	414
	HTR600	28000	85	42000	130	68000	210	505	573	709

<sup>1</sup> Continuous duty – >10<sup>7</sup> cycles    <sup>2</sup> Intermittent duty – <10<sup>4</sup> cycles    <sup>3</sup> Static duty – maximum rating (no dynamic loads)

**Shaft Options**

Keyed and splined shaft designs are available for the HTR Series rotary actuators, in both male and female forms. The standard male, twin key shaft style is illustrated with other major dimensions on pages 6 and 7, while other shaft options are shown below. All the shaft options illustrated are shown in the mid-stroke position. Custom designs, including double-ended shafts, are available to special order – please contact the factory for details.

**Male Splined Shaft**

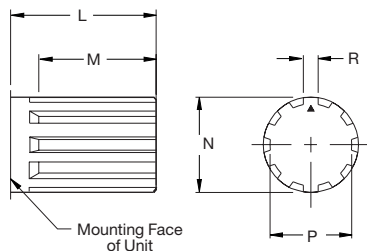

**Male Splined Shaft to DIN/ISO 14**

Model	L	M	N <sub>a11</sub>	P	R	Number of splines
HTR.9 & 1.8	33	22	22	18	5	6
HTR3.7 & 7.5	48	32	28	23	6	6
HTR5 & 10	66	44	42	36	7	8
HTR15 & 30	86	58	54	46	9	8
HTR22 & 45	86	58	54	46	9	8
HTR75 & 150	115	76	72	62	12	8
HTR300 & 600	190	125	125	112	18	10

**Female Keyed Shaft**

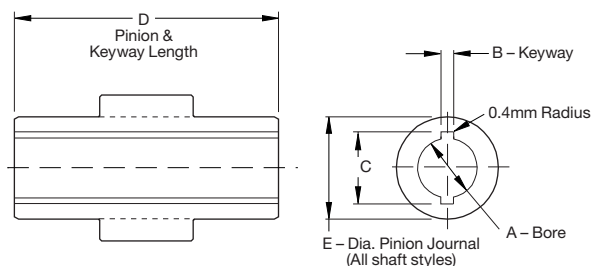

**Female Keyed Shaft to DIN 6885**

Model	A <sub>H7</sub>	B <sub>P9</sub>	C <sup>+0.4</sup>	D	E
HTR.9 & 1.8	16	5	20.6	74.6	25.4
HTR3.7 & 7.5	22	6	27.6	98.4	38.1
HTR5 & 10	32	10	38.6	98.4	44.5
HTR15 & 30	48	14	55.6	125.4	73.0
HTR22 & 45	48	14	55.6	125.4	73.0
HTR75 & 150	72	20	81.8	188.9	95.2
HTR300 & 600	125	32	139.8	303.2	165.1

**Female Splined Shaft**

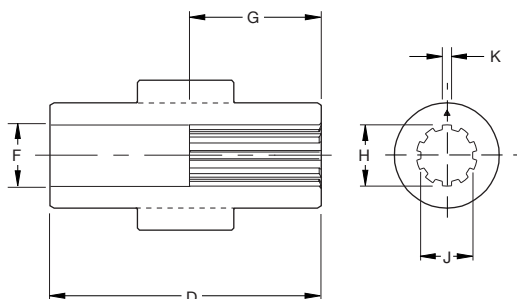

**Female Splined Shaft to DIN/ISO 14**

Model	D	F	G	H <sub>H10</sub>	J <sub>H7</sub>	K	Number of splines
HTR.9 & 1.8	74.6	17	16	16	13	3.5	6
HTR3.7 & 7.5	98.4	23	22	22	18	5	6
HTR5 & 10	98.4	29	29	28	23	6	6
HTR15 & 30	125.4	49	50	48	42	8	8
HTR22 & 45	125.4	49	50	48	42	8	8
HTR75 & 150	188.9	73	76	72	62	12	8
HTR300 & 600	303.2	126	127	125	112	18	10

All dimensions are in millimetres unless otherwise stated.



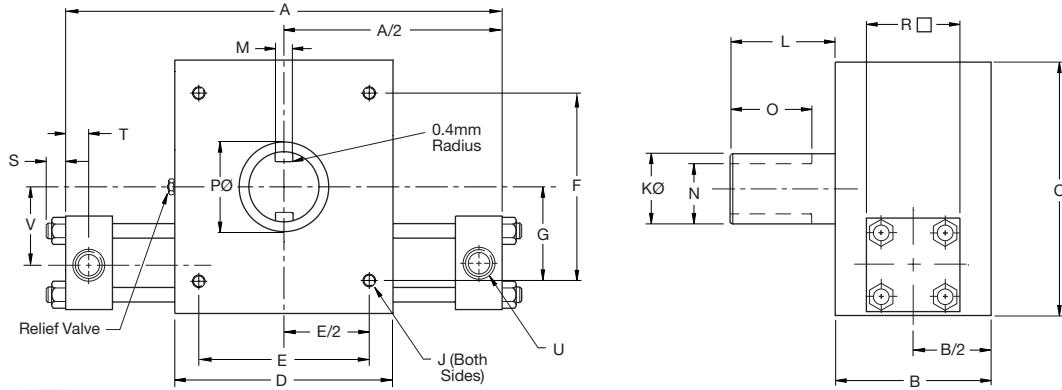

**HTR.9 to HTR5**  
Single Rack Models

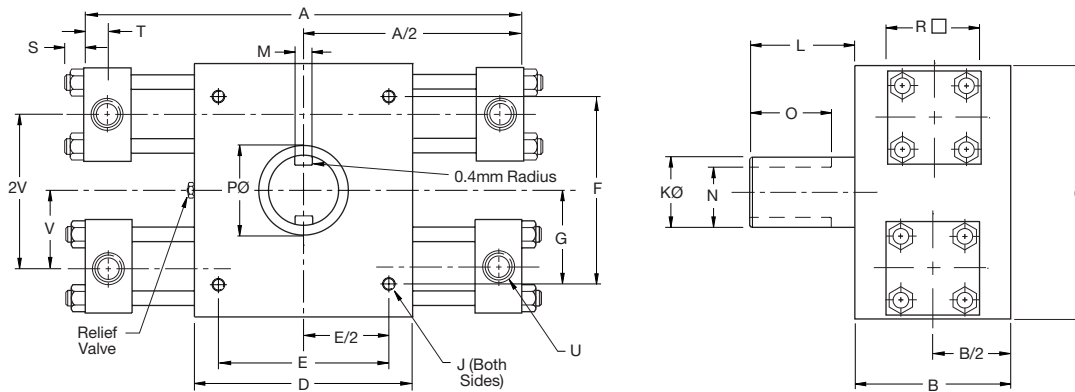

**HTR1.8 to HTR10**  
Double Rack Models

**Dimensions – with Face Mount and Male Keyed Shaft**

Model	Bore	Rotation	A max	B	C	Cd	Cs	D	E ±0.13	F ±0.13	Fd ±0.13	Fs ±0.13	G				
HTR.9	22.2	90°	190	76	92.5	-	-	89	70	60	-	-	30				
HTR1.8		180°	237											360°	333		
HTR3.7	38.1	90°	257	100	133.5	-	-	102	75	90	-	-	45				
HTR7.5		180°	333											360°	464		
HTR5		90°	289											100	152.5	-	-
HTR10	180°	372	360°	562													
HTR15	50.8	90°	406	127	-	-	175	178	150	-	-	50	85				
HTR30		180°	543											360°	816	206.5	-
HTR22	63.5	90°	416	127	-	-	176	178	150	-	-	50	85				
HTR45		180°	553											213	-	170	-
HTR75		360°	822														
HTR150	101.6	90°	514	191	-	-	254	216	165	-	-	115	145				
HTR300		180°	702											327	-	290	-
HTR600	360°	1073	305	-	-	387	403	330	-	-	125	195					
	90°	794											476.5	-	-	-	-
	180°	1111															
	360°	1749															

All dimensions are in millimetres unless otherwise stated.

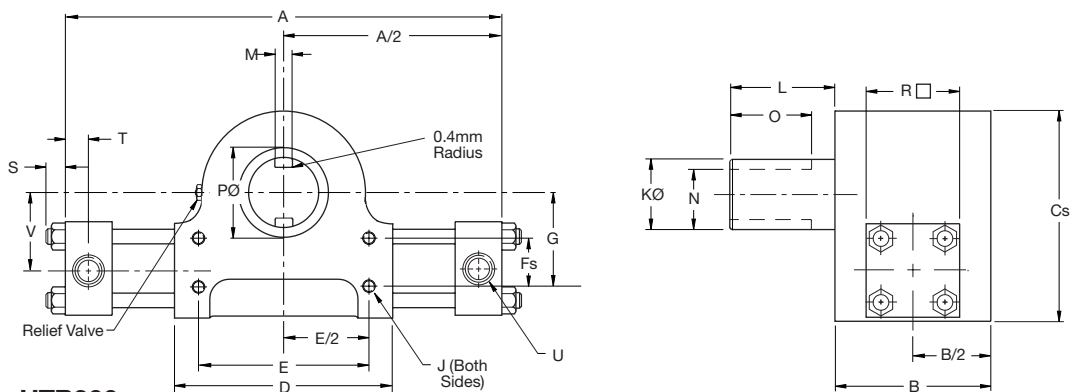

**HTR15 to HTR300**  
Single Rack Models

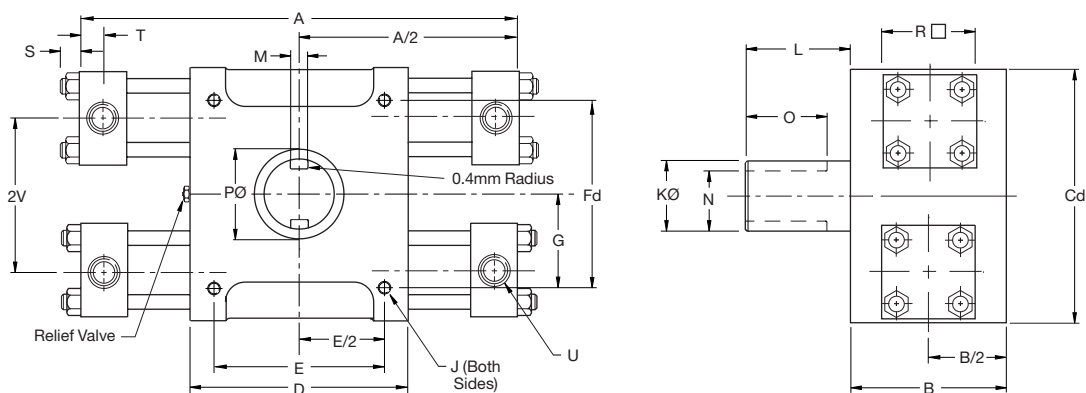

**HTR30 to HTR600**  
Double Rack Models

**Dimensions – with Face Mount and Male Keyed Shaft**

Model	Bore	J	K +0.00 -0.02	L	M P <sub>9</sub>	N	O	P	R	S	T	U (BSPP)	V
HTR.9	22.2	M8x1.25 x 13	22	33	6	18.5 <sup>+0.0</sup> <sub>-0.1</sub>	25	25	45	10	13	G <sup>1</sup> / <sub>4</sub> *	24
HTR1.8													
HTR3.7	38.1	M10x1.5 x 16	28	48	8	24 <sup>+0.0</sup> <sub>-0.2</sub>	38	38	64	13	18	G <sup>1</sup> / <sub>4</sub>	35
HTR7.5													
HTR5													
HTR10	50.8	M10x1.5 x 16	44	66	12	39 <sup>+0.0</sup> <sub>-0.2</sub>	50	45	64	13	18	G <sup>1</sup> / <sub>4</sub>	41
HTR15													
HTR30	63.5	M12x1.75 x 19	54	86	16	48 <sup>+0.0</sup> <sub>-0.2</sub>	60	73	76	16	18	G <sup>1</sup> / <sub>2</sub>	62
HTR22													
HTR45	101.6	M12x1.75 x 19	54	86	16	48 <sup>+0.0</sup> <sub>-0.2</sub>	60	73	89	16	18	G <sup>1</sup> / <sub>2</sub>	62
HTR75													
HTR150	152.4	M20x2.5 x 30	76	115	22	67 <sup>+0.0</sup> <sub>-0.2</sub>	85	95	127	26	21	G <sup>3</sup> / <sub>4</sub>	89
HTR300													
HTR600		M30x3.5 x 48	125	190	32	114 <sup>+0.0</sup> <sub>-0.2</sub>	152	165	191	32	32	G1	130

\* G<sup>1</sup>/<sub>8</sub> when combined with a stroke limiter – see page 11.

All dimensions are in millimetres unless otherwise stated.

**Base and Pilot Mountings**

HTR Series rotary actuators are available with the options of face, base or pilot mounting styles, to suit the requirements of different applications. Mounting dimensions for the face

mounting styles are shown with other major dimensions on pages 6 and 7. The equivalent dimensions for base and pilot mounting styles are shown in the table.

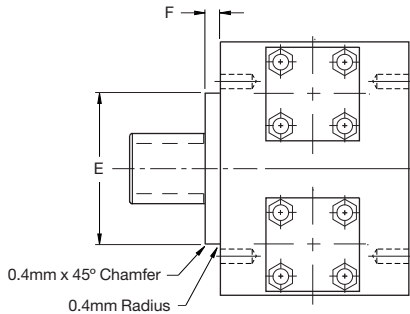

Model	Base Mounting				Pilot Mounting	
	A	B	C	D	E <sup>+0</sup> <sub>-0.05</sub>	F
HTR.9 & 1.8	60	70	M8x1.25 x 13	46.1	47.625	6.5
HTR3.7 & 7.5	75	75	M10x1.5 x 16	66.7	66.675	6.5
HTR5 & 10	75	75	M10x1.5 x 16	76.2	73.025	6.5
HTR15 & 30	100	150	M12x1.75 x 19	103.2	107.950	10
HTR22 & 45	100	150	M12x1.75 x 19	106.4	107.950	10
HTR75 & 150	145	165	M20x2.5 x 30	163.5	139.700	10
HTR300 & 600	240	330	M30x3.5 x 48	238.2	222.250	12

**Pilot Mounting**

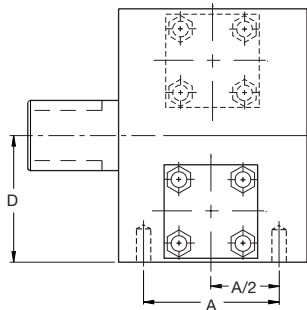

**Base Mounting**

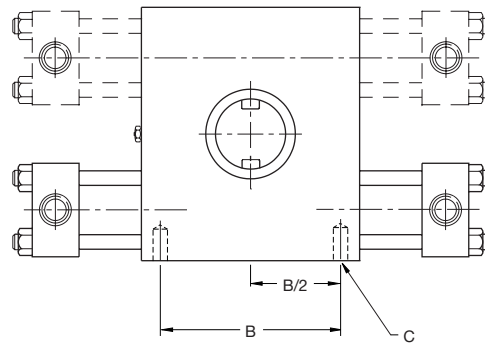

**Port Sizes and Positions**

The standard port style for HTR Series rotary actuators is a BSP (parallel) port, but NPTF, SAE, and metric port styles to DIN 3852/1 and ISO 6149/1 are also available. The relevant sizes of port for each model of rotary actuator are shown in the table.

Ports will be supplied in position 1, as shown in the diagram, unless a different position is specified on the order. Ports are available in positions 2, 3 and 4 at no extra cost; position 5 is available as an extra cost option.

Model	BSP	Metric DIN & ISO	SAE	NPTF
HTR.9 & 1.8	G <sup>1</sup> / <sub>4</sub>	M14x1.5	<sup>9</sup> / <sub>16</sub> -18 (SAE 6)	<sup>1</sup> / <sub>4</sub>
HTR3.7 & 7.5	G <sup>1</sup> / <sub>4</sub>	M14x1.5	<sup>9</sup> / <sub>16</sub> -18 (SAE 6)	<sup>1</sup> / <sub>4</sub>
HTR5 & 10	G <sup>1</sup> / <sub>4</sub>	M14x1.5	<sup>9</sup> / <sub>16</sub> -18 (SAE 6)	<sup>1</sup> / <sub>4</sub>
HTR15 & 30	G <sup>1</sup> / <sub>2</sub>	M22x1.5	<sup>3</sup> / <sub>4</sub> -16 (SAE 8)	<sup>1</sup> / <sub>2</sub>
HTR22 & 45	G <sup>1</sup> / <sub>2</sub>	M22x1.5	<sup>3</sup> / <sub>4</sub> -16 (SAE 8)	<sup>1</sup> / <sub>2</sub>
HTR75 & 150	G <sup>3</sup> / <sub>4</sub>	M27x2	<sup>1</sup> / <sub>16</sub> -12 (SAE 12)	<sup>3</sup> / <sub>4</sub>
HTR300 & 600	G1	M33x2	<sup>1</sup> / <sub>16</sub> -12 (SAE 16)	1

**Air Bleeds**

These may be fitted in positions unoccupied by ports.

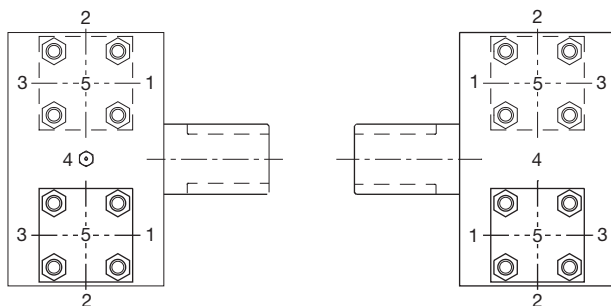

All dimensions are in millimetres unless otherwise stated.



**Cushions and  
Cushion Adjustment Location**

Cushioning is recommended as a means of controlling the deceleration of masses. Machine life is extended as a result of the reduced shock, permitting faster cycle times with lower levels of noise. Cushions are recommended for high kinetic energy applications and/or where the full rotation of the actuator is being used. They are available as an option on all HTR Series rotary actuators, for one or both rotations, and do not affect the actuator's envelope or mounting dimensions. For the HTR Series rotary actuator, the standard angle of cushioning is 20° (0.349 rads).

Each cushion is adjustable individually, allowing cushion performance to be matched to the application. The positions of cushion adjusters, relative to port positions, are shown in the table – numbers relate to the diagram of port positions on page 8.

\* Single rack models only

Port Position	Cushion Position
1	2
2	3
3	2
4 *	3
5	2

**Note:** Where cushioning is required on double rack units, the High Performance Cushion option described on page 10 should be specified.

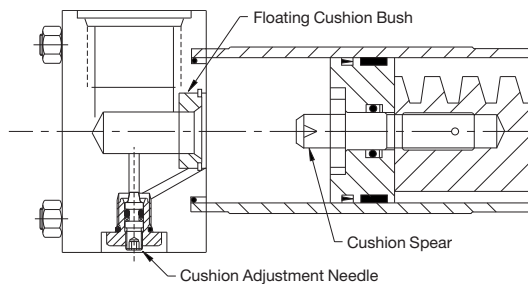

Note that cushion performance will be affected by the use of high water content fluids. Please consult the factory for details.

The energy absorption capacity of the cushion decreases with drive pressure, which in normal circuits is the relief valve pressure.

**Formulae**

For a load that moves in the horizontal plane, only the kinetic energy need be considered. If the load is to move vertically, then the potential energy change of the load during cushioning must also be taken into account. Both conditions are described by the following equations. The resulting figure for energy to be absorbed can then be applied to the graph of Cushion Energy Absorption Capacity, to identify a rotary actuator with adequate cushion capacity.

**Note:** the graph of Cushion Energy Absorption Capacity should only be used for initial sizing. For accurate sizing, please contact the factory.

For masses moving horizontally:

$$E = \frac{1}{2} J_m \omega^2$$

For masses moving downwards:

$$E = \frac{1}{2} J_m \omega^2 + mgR\theta$$

For masses moving upwards:

$$E = \frac{1}{2} J_m \omega^2 - mgR\theta$$

Where:

- E = energy to be absorbed, Joules
- J<sub>m</sub> = rotational mass moment of inertia, kgm<sup>2</sup>
- ω = rotational velocity of load, rads/sec
- m = mass of load, kg
- g = acceleration due to gravity, 9.81m/s<sup>2</sup>
- R = radius of rotation, m
- θ = angle of cushioning, radians (0.349 rads = 20°)

**Example**

- P = 100 bar
- m = 200 kg
- R = 0.2 m
- ω = 6 rpm
- Standard cushions = 20° = 0.349 rads.

$$E = \frac{1}{2} J_m \omega^2 + mgR\theta$$

$$E = \left( \frac{1}{2} \times [200 \times 0.2^2] \times 6 \times \left[ \frac{2\pi}{60} \right]^2 \right) + (200 \times 9.81 \times 0.2 \times 0.349)$$

$$E = 1.6 + 136.9$$

$$E = 138.5 \text{ Joules}$$

From the graph of Cushion Energy Absorption Capacity, it can be seen that an HTR7.5 (double rack unit) is capable of absorbing this energy where the High Performance Cushion option is specified. An HTR15 (single rack unit) is also capable of absorbing this energy.

**High Performance Cushions**

The High Performance cushion option can only be specified on double rack rotary actuators. Double rack rotary actuators can achieve very high torques, to move large masses which need to be decelerated at the end of travel. This cushion energy is absorbed efficiently by the use of High Performance cushions. External piping ensures that during cushioning the maximum deceleration torque is available. External interconnecting pipework for the High Performance cushion is not supplied with the rotary actuator.

**Operation**

The work ports of a standard directional valve are connected directly to ports C-1 and C-2 of the rotary actuator, as shown. Port A-1 is connected directly to A-2, and B-1 is connected directly to B-2. When pressure is applied directly to port C-1 (clockwise shaft rotation), fluid is also directed through line A to the other rack. Exhaust flow from B-1 and B-2 is directed through the cushion bush and cushion adjustment screw until the cushion spear closes off the main passage. The total flow from both end caps is then directed across one cushion adjustment screw, equalizing back pressure and improving cushion performance. Pressurizing C-2 and exhausting C-1 reverses the operation.

**Notes**

1. Pipework between A-1 and A-2, and B-1 and B-2 should be kept to a minimum to reduce the inertia of the fluid. Fluid flow should be less than 5m/s.
2. Connection ports will have the same specification as the working ports.

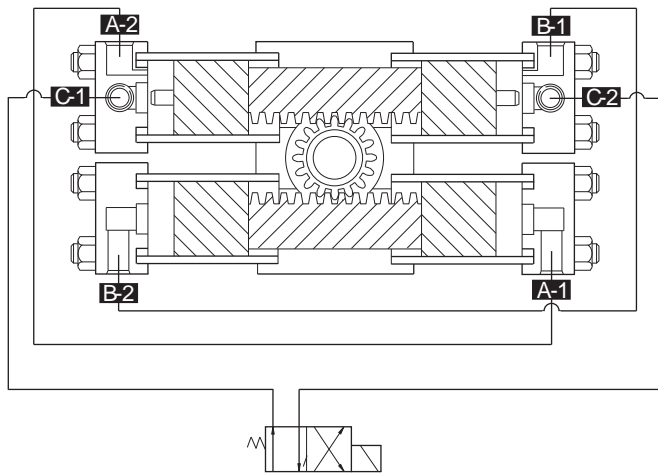

**Cushion Energy Absorption Capacity – All Cushion Options**

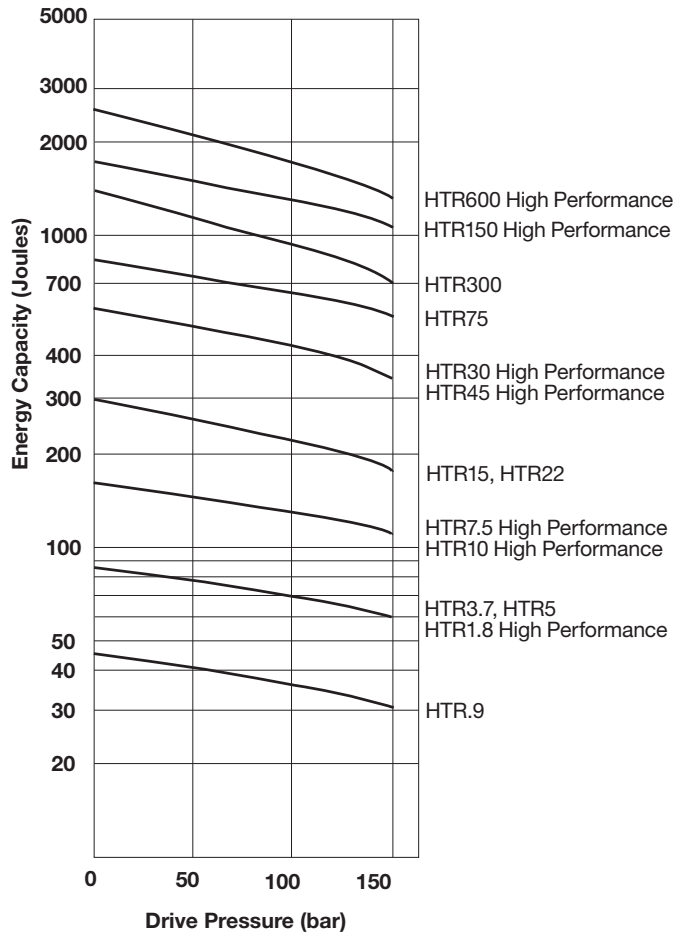

**Note:** Cushion performance may be affected by the addition of a stroke limiter. Please consult the factory in critical applications.

**Port Positions**

Rotary actuators with High Performance Cushions differ from standard double rack units only in their port positions – all external dimensions of the units remain unaltered.

Work Ports C-1 & C-2 Port Position	Cushion Adjuster Position	Connection Ports A-1, A-2, B-1, B-2 Port Position
1	2	3
2	3	1
3	2	1
5	2	3

**Piston Seals and Seal Kits**

The Wear-Pak piston fitted as standard to all HTR Series rotary actuators employs a polyurethane seal to contain hydraulic pressure, and a PTFE wear ring (not for HTR.9 or HTR1.8) to prevent metal-to-metal contact. For higher temperatures or use with synthetic fluids, FPM seals should be specified for the piston; for water glycol or high water content fluids, nitrile seals are available.

become over-pressurized. Any external leakage from the gear housing, therefore, is indicative of worn or damaged piston seals and these should be examined and, if necessary, replaced, at the earliest opportunity.

**Note:** it is essential that all hydraulic lines are thoroughly flushed before connection to the rotary actuator.

**Filtration**

Effective filtration is vital to the long life and satisfactory performance of a rotary actuator. If the piston seals of a rack and pinion rotary actuator are worn or damaged, fluid which leaks past the piston will enter the gear housing.

In the event of internal leakage into the gear housing, the pressure relief valve will ensure that the housing does not

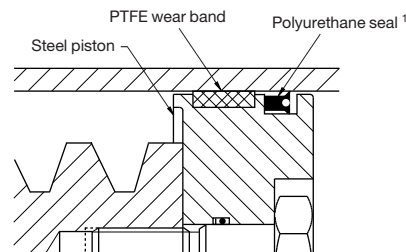

Seal Class	Materials		Fluid Medium	Temperature Range	Seal Kit Code	Filtration
	Seal	Wear Ring				
Standard	Polyurethane	Filled PTFE	General purpose, petroleum-based fluids	-30° to +80°	PSKHTR.9 <sup>2</sup>	ISO class 17/14 cleanliness level
V	FPM	Filled PTFE	High temperature and/or synthetic fluids	-20° to +150°	PSKHTR.9V <sup>2</sup>	
W	Carboxylated Nitrile	Filled PTFE	Water glycol, high water content fluids	0° to +80°	PSKHTR.9W <sup>2</sup>	

<sup>1</sup> FPM seals also include a back-up washer.

<sup>2</sup> The part numbers shown are for HTR.9 models. For other models,

replace '.9' with the appropriate size. For example, an FPM seal kit for an HTR15 will be PSKHTR15V.

**Stroke Limiters**

Fine control of the end of travel points of the rotary actuator can be obtained by specifying stroke limiters. These operate by reducing the maximum rotation of the actuator within preset limits of either 5° or 30° in each direction. Adjustment within this range is infinitely variable and may be carried out by the user. Several types of stroke limiter are available – the design illustrated is suitable for applications requiring infrequent adjustment.

fitted to the upper rack and the stroke limiter to the lower. The increase in build length, for both single and double rack units, is shown as dimension A in the table. Cushion performance may be affected by the addition of a stroke limiter. Please consult the factory in critical applications.

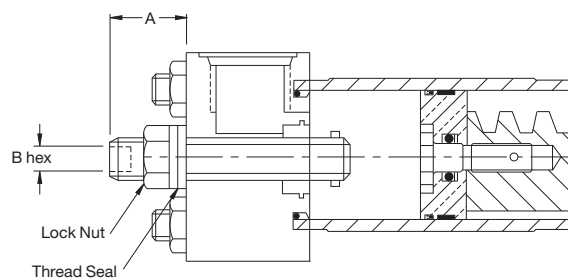

**Stroke Limiters and Cushions**

5° stroke limiters may be combined with the cushioning devices shown on page 10. 30° stroke limiters cannot be combined with cushions.

The addition of stroke limiters requires an increase in build length. On double rack units with cushions, the cushion is

Model	Adjustment per Full Turn	A max – Increased Build Length			B Hex Socket Screw in.
		5° Limiter Without Cushion	5° Limiter With Cushion	30° Limiter Without Cushion	
HTR.9 & 1.8	4.0°	13	22	19	5/32
HTR3.7 & 7.5	3.3°	16	29	29	1/4
HTR5 & 10	2.5°	16	29	29	1/4
HTR15 & 30	2.0°	22	46	41	3/8
HTR22 & 45	2.0°	22	46	41	3/8
HTR75 & 150	2.0°	65	95	90	Square adjuster
HTR300 & 600	1.2°	90	154	N/A	

All dimensions are in millimetres unless otherwise stated.

### Bearing Load Capacities

The radial and thrust loads and overhung moments which can be supported by each model of HTR rotary actuator at different operating pressures are shown in the table. These figures should be read in conjunction with the notes below.

#### Notes

- 1 Static bearing load capacities = dynamic values x 1.5
- 2 Standard male shafts provide a 4:1 design factor. At the operating conditions marked \*, a smaller design factor is achieved and the values listed are 'bearing' moment capacities. For higher capacities, larger shaft sizes are available – please consult the factory for details.

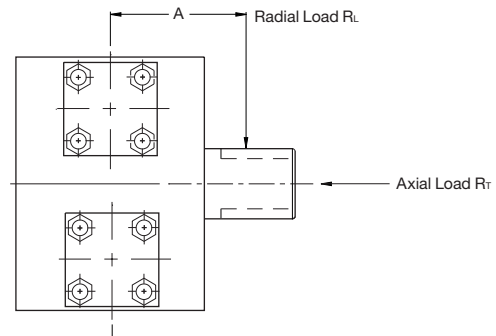

### Dynamic Bearing Load Capacities vs. Operating Pressure

Model	Radial Load kN $R_L$ per Bearing @			Thrust Load kN $R_T$ @			Overhung Moment kN.m $R_L \times A$ @		
	70 Bar	140 Bar	210 Bar	70 Bar	140 Bar	210 Bar	70 Bar	140 Bar	210 Bar
HTR.9	16.6	15.2	13.9	12.0	11.5	11.1	0.28	0.25	0.23
HTR1.8	17.9	17.9	17.9	12.4	12.4	12.4	0.30	0.30	0.30 *
HTR3.7	26.3	22.2	18.3	16.1	15.0	13.9	0.71	0.59	0.49
HTR7.5	30.0	30.0	30.0	17.0	17.0	17.0	0.80	0.80	0.80 *
HTR5	34.1	30.2	26.3	18.9	17.9	17.0	0.87	0.77	0.67
HTR10	38.1	38.1	38.1	19.9	19.9	19.9	0.97	0.97	0.97
HTR15	61.4	54.4	47.4	54.7	52.6	50.4	2.85	2.53	2.20
HTR30	68.4	68.4	68.4	56.9	56.9	56.9	3.18	3.18	3.18
HTR22	57.9	47.4	–	53.7	50.4	–	2.69	2.20	–
HTR45	68.4	68.4	–	56.9	56.9	–	3.18	3.18	–
HTR75	72.7	44.8	16.8	73.6	62.6	51.5	7.37	4.54	1.70
HTR150	100.7	100.7	100.7	84.6	84.6	84.6	10.20	10.20 *	10.20 *
HTR300	129.3	66.4	3.4	107.2	87.7	68.3	19.53	10.02	0.52
HTR600	192.2	192.2	192.2	126.7	126.7	126.7	29.04	29.04	29.04 *

### Position Switches

Accurate end of rotation indication can be obtained by specifying position switches. These solid state, inductive-type switches are fitted to the caps of the hydraulic cylinders, where a non-contacting probe senses the presence of a ferrous spear attached to the piston. Position switches are not available on rotary actuators fitted with stroke limiters.

Both flange mounted (EPS-6 and EPS-7) and threaded type (PS201/2/3) position switches are available. Both types of switch can be used to operate relay coils, or as direct input to a PLC. All switches incorporate short-circuit protection. The fault condition must be corrected and the power disconnected in order to reset the switch, preventing automatic restarts.

Two LEDs (in the switch or in the connector) indicate power and switch status.

### CE Marking

The position switches fitted by Parker are CE marked to certify that they meet the requirements of the EC Directive 89/336/EEC for electromagnetic compatibility.

### DC 3-wire Sensor (PS201, 202 and 203)

#### Wiring Diagram

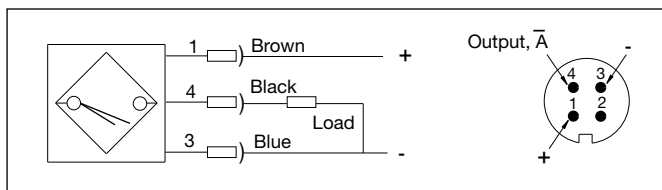

#### Dimensions

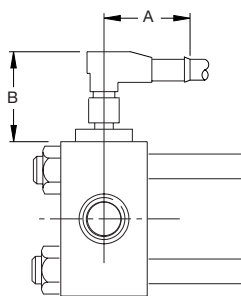

Model	PS201, 202 & 203	
	A	B
HTR.9 & 1.8	Consult factory	
HTR3.7 & 7.5	32	
HTR5 & 10	63	
HTR15 & 30	86	
HTR22 & 45	79	
HTR75 & 150	67	
HTR300 & 600	88	

### DC 4-wire Sensor (EPS-6)

#### Wiring Diagram

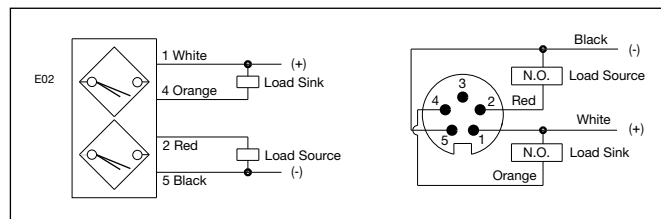

### AC/DC 2-wire Sensor (EPS-7)

#### Wiring Diagram

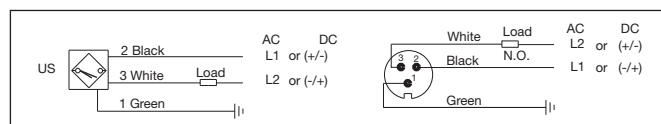

### Dimensions

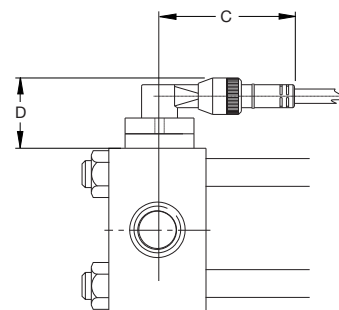

**Note:** Connectors not supplied. Please order as an accessory.

Model	EPS-6 & EPS-7	
	C	D
HTR.9 & 1.8	105	52
HTR3.7 & 7.5		65
HTR5 & 10		65
HTR15 & 30		62
HTR22 & 45		56
HTR75 & 150		43
HTR300 & 600		83

Sensor Type	EPS-6	PS201, 202 & 203	EPS-7
Connector	105000A01F060	PS 011	103000A01F060
Output Function	PNP/NPN, normally open	PNP, normally open	Normally open
Operating Voltage	10–30V DC	10–30V DC	20–250V AC @ 40–60Hz 20–300V DC
Operating Current	< 200 mA	200 mA	< 300 mA
Operating Temperature	-25°C to +70°C	-25°C to +80°C	-25°C to +70°C
Protection Class	IP67	IP67 to IEC60529	IP67
Connector Orientation	direct, switching	dependent on switch adjustment	direct, switching
Signal	in sensor	in connector	in sensor

All dimensions are in millimetres unless otherwise stated.

**Feedback Devices**

A linear feedback device or a position sensor can be supplied for continual monitoring of the rotational range.

The linear feedback device is built into the cap of the cylinder and registers the position of the rack, and thus indirectly of the pinion. This type of position feedback is offered when the rotational range is greater than 355°.

The position sensor is mounted at the back of the housing and directly registers the position of the pinion.

**Linear Feedback Devices**

Linear feedback devices are supplied with an optional ultrasonic feedback system. Other types of feedback devices with alternative analogue or digital output signals are available on request. Please consult the factory for further information.

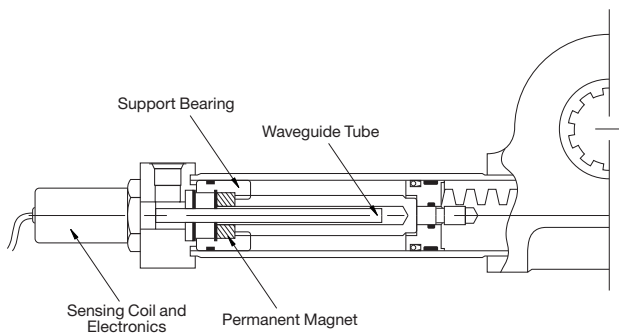

**Note**

When considering rotary actuator applications using a sensor, it should be borne in mind that rack and pinion actuators have a small amount of backlash. This can be overcome by use of a special hydraulic circuit. Please consult the factory for details.

**Angular Position Transducer**

Angular position transducers are supplied with a rotary potentiometer, which requires user input. Integral signal conditioning is also available as an option.

**Technical Data**

**Potentiometer**

Type:	single turn precision servo-mount with conductive plastic element
Port:	Connector LXES-0033 <sup>1</sup>
Effective mechanical angle:	360°
Effective electrical angle:	355° ±2°
Resistance:	5 kΩ
Resistance tolerance:	±20%
Linearity:	±0.075%
Maximum voltage:	42V DC
Maximum current:	10 mA
Recommended operating current:	< 1 μA
Temperature rating:	-40°C to +100°C
Protection class:	IP65

**Potentiometer with Integral Signal Conditioning**

Type:	single turn precision servo-mount with conductive plastic element
Port:	Connector LXES-0033 <sup>1</sup>
Effective mechanical angle:	360°
Effective electrical angle:	90° or 345°
Output signal:	0–20 or 4–20 mA
Current:	30 mA
Load resistance:	0–500 Ω
Linearity:	±0.1% (345°) ±3% (90°)
Repeatability:	0.007°
Operating voltage:	24V DC
Temperature rating:	-25°C to +70°C
Protection class:	IP65

<sup>1</sup> Available as an accessory – please specify in order

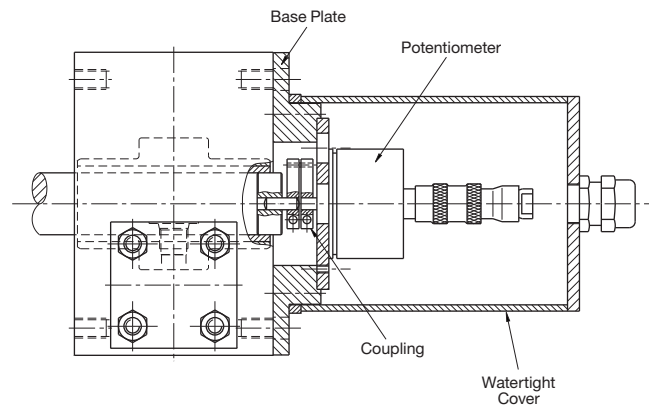



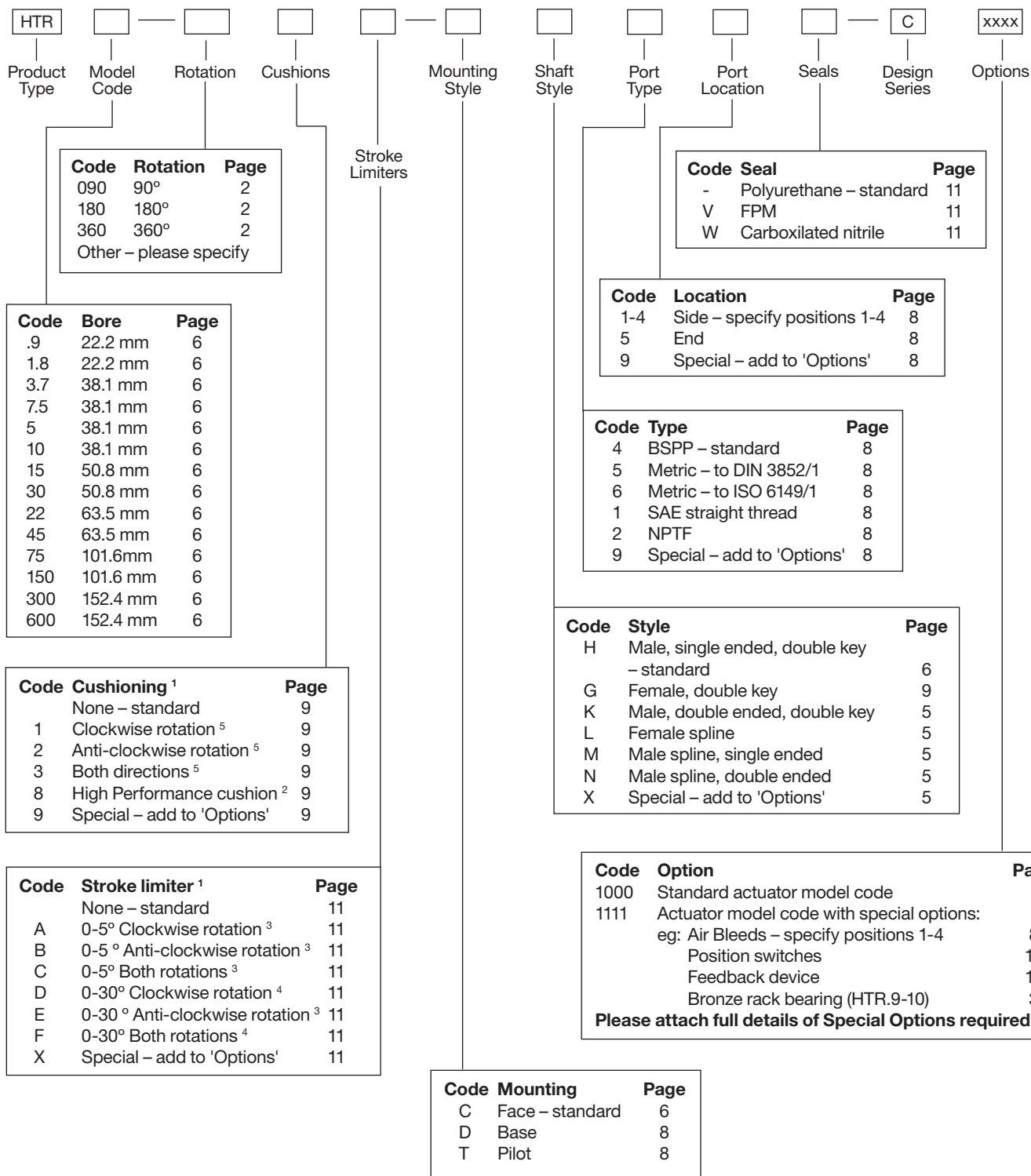

**Maintenance and Spare Parts**

Full instructions for the maintenance of HTR Series rotary actuators, together with a complete list of the spares available, is contained in the HTR Series Rotary Actuator Maintenance Bulletin. Please ask for bulletin HY07-1220/M.

**Notes:**

- <sup>1</sup> Viewed from shaft end
- <sup>2</sup> Double rack models only
- <sup>3</sup> Not available with end ports
- <sup>4</sup> Not available with end ports and cushions
- <sup>5</sup> Only available on single rack units

# Sales Offices

**AE – United Arab Emirates,**  
Abu Dhabi  
Tel: +971 2 67 88 587

**AR – Argentina,** Buenos Aires  
Tel: +54 3327 44 4129

**AT – Austria,** Wiener Neustadt  
Tel: +43 (0)2622 23501-0

**AT – Austria,** Wiener Neustadt  
(Eastern Europe)  
Tel: +43 (0)2622 23501 970

**AU – Australia,** Castle Hill  
Tel: +61 (0)2-9634 7777

**AZ – Azerbaijan,** Baku  
Tel: +994 50 2233 458

**BE – Belgium,** Nivelles  
Tel: +32 (0)67 280 900

**BR – Brazil,** Cachoeirinha RS  
Tel: +55 51 3470 9144

**BY – Belarus,** Minsk  
Tel: +375 17 209 9399

**CA – Canada,** Milton, Ontario  
Tel: +1 905 693 3000

**CH – Switzerland**  
See Germany

**CN – China,** Shanghai  
Tel: +86 21 5031 2525

**CN – China,** Beijing  
Tel: +86 10 6561 0520

**CZ – Czech Republic,** Klecany  
Tel: +420 284 083 111

**DE – Germany,** Kaarst  
Tel: +49 (0)2131 4016 0

**DK – Denmark,** Ballerup  
Tel: +45 43 56 04 00

**ES – Spain,** Madrid  
Tel: +34 902 33 00 01

**FI – Finland,** Vantaa  
Tel: +358 (0)20 753 2500

**FR – France,**  
Contamine-sur-Arve  
Tel: +33 (0)4 50 25 80 25

**GR – Greece,** Athens  
Tel: +30 210 933 6450

**HK – Hong Kong**  
Tel: +852 2428 8008

**HU – Hungary,** Budapest  
Tel: +36 1 220 4155

**IE – Ireland,** Dublin  
Tel: +353 (0)1 466 6370

**IN – India,** Mumbai  
Tel: +91 22 6513 7081-85

**IT – Italy,** Corsico (MI)  
Tel: +39 02 45 19 21

**JP – Japan,** Fujisawa  
Tel: +(81) 4 6635 3050

**KR – South Korea,** Seoul  
Tel: +82 2 559 0400

**KZ – Kazakhstan,** Almaty  
Tel: +7 3272 505 800

**LV – Latvia,** Riga  
Tel: +371 74 52601

**MX – Mexico,** Apodaca  
Tel: +52 81 8156 6000

**MY – Malaysia,** Subang Jaya  
Tel: +60 3 5638 1476

**NL – The Netherlands,**  
Oldenzaal  
Tel: +31 (0)541 585 000

**NO – Norway,** Ski  
Tel: +47 64 91 10 00

**NZ – New Zealand,** Mt Wellington  
Tel: +64 9 574 1744

**PL – Poland,** Warsaw  
Tel: +48 (0)22 573 24 00

**PT – Portugal,** Leca  
da Palmeira  
Tel: +351 22 999 7360

**RO – Romania,** Bucharest  
Tel: +40 21 252 1382

**RU – Russia,** Moscow  
Tel: +7 495 645-2156

**SE – Sweden,** Spånga  
Tel: +46 (0)8 59 79 50 00

**SG – Singapore**  
Tel: +65 6887 6300

**SL – Slovenia,** Novo Mesto  
Tel: +386 7 337 6650

**SK – Slovakia**  
See Czech Republic

**TH – Thailand,** Bangkok  
Tel: +662 717 8140

**TR – Turkey,** Merter/Istanbul  
Tel: +90 212 482 91 06 or 07

**TW – Taiwan,** Taipei  
Tel: +886 2 2298 8987

**UA – Ukraine,** Kyiv  
Tel +380 44 494 2731

**UK – United Kingdom,**  
Warwick  
Tel: +44 (0)1926 317 878

**US – USA,** Cleveland  
(Industrial)  
Tel: +1 216 896 3000

**US – USA,** Lincolnshire  
(Mobile)  
Tel: +1 847 821 1500

**US – USA,** Miami  
(Pan American Division)  
Tel: +1 305 470 8800

**VE – Venezuela,** Caracas  
Tel: +58 212 238 5422

**ZA – South Africa,**  
Kempton Park  
Tel: +27 (0)11 961 0700

