

Oil Level Adaptor Kits

Installation Instructions

Bulletin 110-11, December 2015

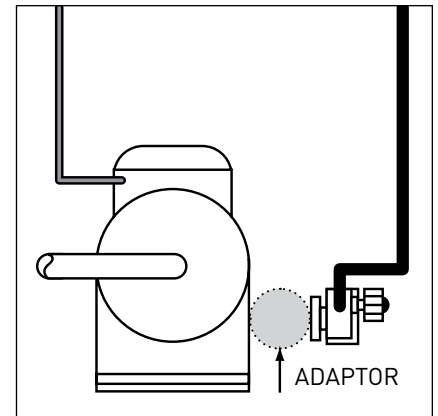

GENERAL – The oil level adaptor kits described below are used to attach the Sporlan oil level control to the sightglass connection on the compressor housing. In addition to the adaptor fitting, the kits contain the necessary bolts, nuts, O-ring, and sightglass (except AOL-R-1). All Sporlan oil level controls have the same 7 bolt universal flange connection. The adaptor kits permit installing the oil level control onto compressors with various threads or mounting hole configurations.

INSTALLATION – The overall procedure is to remove the existing sightglass on the compressor, install the oil level **adaptor** in its place, and then attach the oil level **control** to the adaptor. This procedure requires the following steps:

1. Follow the procedure suggested by the compressor manufacturer if the procedure is available. Otherwise the following steps are suggested.
2. Shut off the power to the compressor involved and close the suction service valve, or other valves to isolate the compressor.
3. Release the refrigerant pressure in the compressor by opening an appropriate connection (for example, loosen the connection on the low pressure control). Drain the oil to a level below the bottom of the sightglass. This can be done through a drain plug, or by pulling the oil out through the filler connection with a pump.
4. Remove the sightglass from the compressor. This will require unbolting or unscrewing the sightglass.
5. **Attach the adaptor to the compressor.** The AOL-A and AOL-C are machine threads and are sealed with an O-ring. The O-ring will seal better if it is lubricated with a light film of oil. The AOL-R-1 bolts to the compressor. See Figure 1.

NOTE: The bolt holes on the sightglass and oil level control are **not equally spaced**. Be sure to line the holes up properly. The mark on the edge of the flange indicates the top.

6. Attach the sightglass plate to the oil level control. The side of the sightglass plate with the O-ring groove goes toward the flange on the oil level control. The **sightglass may be attached to either arm of the oil level control**. Bolts are provided, as well as an O-ring and quad ring. Since both of the mating parts contain a groove, the use of the O-ring and quad ring combination permits getting a proper seal. Tighten the bolts and nuts to approximately 6 ft.-lbs. torque.
7. The oil level should always be adjusted to the level specified by the manufacturer. The oil level control can be **adjusted before use** by following the instructions given in Sporlan Bulletin 110-10 or Form SD-129 supplied with the oil level control.
8. **Attach the oil level control** (with sightglass) to the adaptor (already installed) using the bolts, nuts, and O-ring provided.
9. Connect the oil supply line from the reservoir to the flare fitting on top of the oil level control.
10. Some oil level controls incorporate an oil equalization fitting. If the system requires this connection, connect the 3/8" flare fitting on the side of the oil level control to the oil equalization line. If the equalizer is not required, a cap must be installed.
11. Refill the crankcase with oil to the proper level. Evacuate the compressor and oil level control. Open the service valve to pressurize the compressor and oil level system. Test for leaks. Then start the unit following the manufacturer's recommendations.

Sporlan oil level controls are listed by Underwriters Laboratories for use with Refrigerants 134a, 22, 404A, 407C, and 507. The controls have a maximum rated pressure of 650 psi (45 bar).



ENGINEERING YOUR SUCCESS.

OIL LEVEL CONTROL ADAPTOR KITS

Figure 1

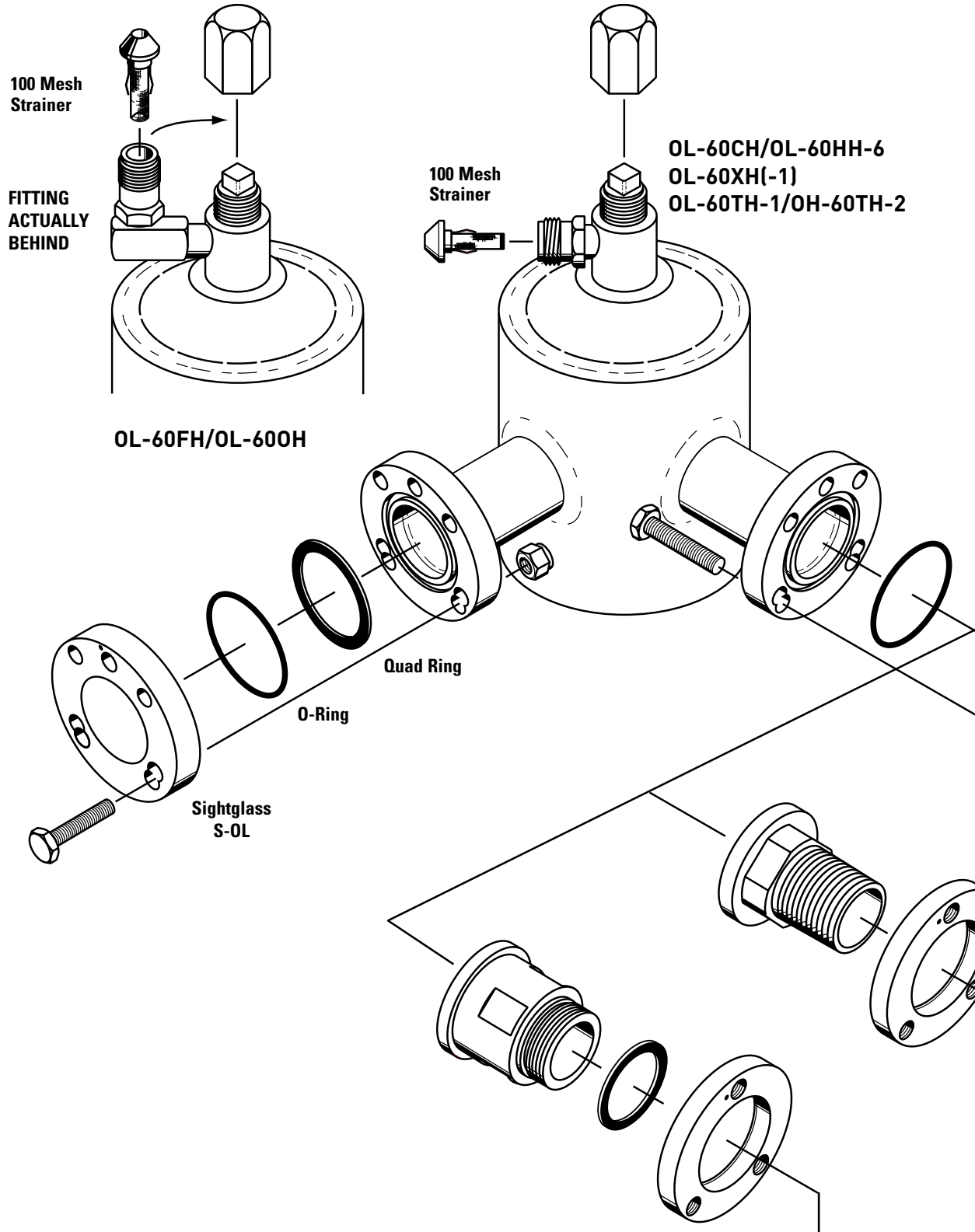

AOL-MA/TE (968026)

- 3 1/4 - 20 x 2" Bolts
- 1 Sightglass
- 2 O-Rings
- 1 Teflon Gasket
- 1 Compressor O-Ring

NOTE: Mechanical oil level control not recommended for scroll compressors.

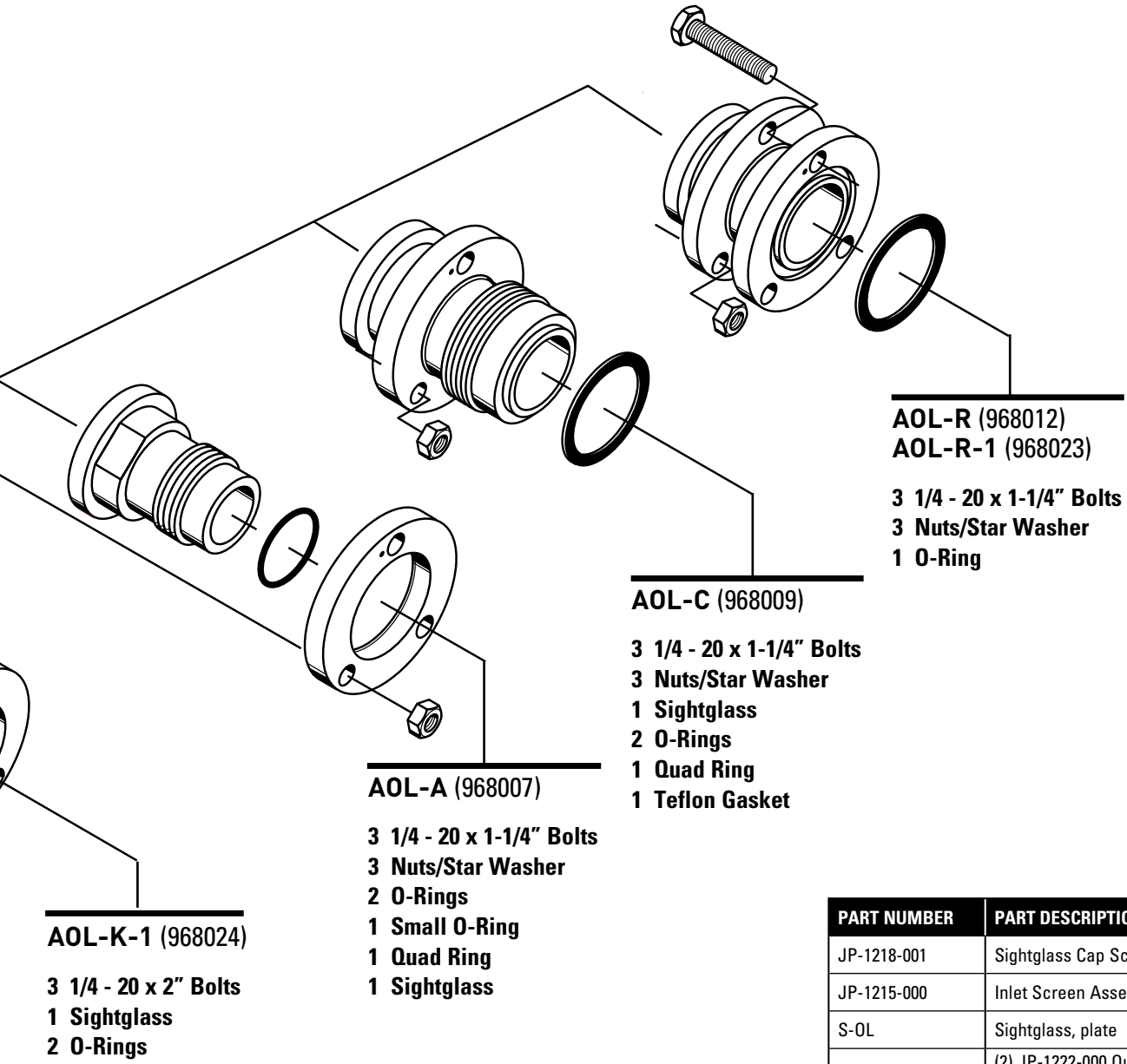

PART NUMBER	PART DESCRIPTION
JP-1218-001	Sightglass Cap Screws 1/4 - 20 x 1
JP-1215-000	Inlet Screen Assembly
S-OL	Sightglass, plate
K-OL-Parts-Kit (968031)	(2) JP-1222-000 Quad Ring (2) 0621-125 O-ring (4) JP-1218-001 1/4 - 20 x 1 Cap Screws (4) JP-1223-000 1/4 - 20 Locknuts
K-OL-Seal-Kit (968029)	(1) 0621-024 O-ring (1) 0621-118 O-ring (3) 0621-125 O-ring (1) JP-1222-000 Quad Ring (1) JP-0745-000 Seal Ring (1) 4238-000 Seal Ring

SPECIFICATIONS

COMPRESSOR MANUFACTURER	COMPRESSOR MODEL NUMBER	COMPRESSOR ATTACHMENT PATTERN	SPORLAN ADAPTOR KIT NUMBER	SEALING METHOD	SIGHTGLASS
Bitzer	2KC, 2JC, 2HC, 2GC, 2 FC, 2EC, 2DC, 2CC, 4FC, 4EC, 4DC, 4CC	1-1/8" Thread	AOL-MA/TE	Use seal provided	Use sightglass provided with adaptor
	4VC, 4TC, 4PC, 4NC	3 Bolt, 1-7/8" B.C. (47.6 mm B.C.)	None	Use seal provided	Use sightglass from compressor
	4J, 4H, 4G, 6J, 6H, 6G, 6F	4 Bolt, 50 mm B.C.	None	Use seal provided with control	Use sightglass from compressor
	8GC, 8FC	3 Bolt, 1-7/8" B.C. (47.6 mm B.C.)	AOL-R-1	Use seal provided	Use sightglass from compressor
Bock	F...	3 Bolt, 1-7/8" B.C. (47.6 mm B.C.)	AOL-R-1	Use seal provided	Use sightglass from compressor
Carrier	06EA, 06ER	3 Bolt, 1-7/8" B.C. (47.6 mm B.C.)	AOL-R-1	Use seal provided	Use sightglass from compressor
	06DA, 06DR, 5F, 5H	1-1/2" – 18 Thread	AOL-C		Use sightglass provided with adaptor
Copeland	Over 5 Ton	3 Bolt, 1-7/8" B.C. (47.6 mm B.C.)	AOL-R-1	Use seal provided	Use sightglass from compressor
	Under 5 HP®	1-1/8" – 12 Thread	AOL-A	Use seal from compressor	Use sightglass provided with adaptor
	8R, 3D Front, 2D, 4D, 6D	3 Bolt, 1-7/8" B.C. (47.6 mm B.C.)	AOL-R-1	Use seal provided	Use sightglass from compressor
	8D	3 Bolt, 1-7/8" B.C. (47.6 mm B.C.)	Use control with standard length arms with AOL-R-1 adaptor. Use sightglass from compressor		
Dorin	4 cyc-15 HP	3 Bolt, 1-7/8" B.C. (47.6 mm B.C.)	Contact Sporlan		
Dunham-Bush	Big 4	3 Bolt, 1-7/8" B.C. (47.6 mm B.C.)	AOL-R-1	Use seal provided	Use sightglass from compressor
Frascold	All models	3 Bolt, 1-7/8" B.C. (47.6 mm B.C.)	AOL-R-1	Use seal provided	Use sightglass from compressor
Maneurop	MT..., LT...	1-1/8" – 18 Thread	AOL-MA/TE	Use seal provided	Use sightglass provided with adaptor
Tecumseh	P, R, S, PA, RA, SA, CK, CM, CH, CG	1-1/8" – 12 Thread	AOL-A	Use seal from compressor	Use sightglass provided with adaptor
	—	1-1/8" – 18 Thread	AOL-MA/TE	Use seal provided	
	VS	3/4" – 14 Thread	AOL-K-1	Use seal provided	
Trane	M, R	3 Bolt, 1-7/8" B.C. (47.6 mm B.C.)	AOL-R-1	Use seal provided	Use sightglass from compressor
	K	3/4" NPT	AOL-K-1	Use Teflon tape	Use sightglass provided with adaptor
York	GC, GS, JS	3 Bolt, 1-7/8" B.C. (47.6 mm B.C.)	AOL-R-1	Use seal provided	Use sightglass from compressor

Shipping weight is 4 lbs. (1.8 Kg) for oil level controls and 1 lb. (0.45 Kg) for adaptors.

① Some compressor models have a smaller diameter port than the arm diameter of the oil level control. This situation can mislead the control in the amount of oil that is actually in the compressor. It is advisable the selection and adjustment of the control be reviewed in this situation.

To diagnose a problem of poor level control keep in mind that system problems are frequently the cause rather than a defective Oil Level Control. For example,

Low oil level is caused by:

- Insufficient oil in the system.
- A plugged oil filter.
- Oil being pulled out through the equalizer line.

High oil level is caused by:

- Oil returning through the suction line.
- Oil that gets trapped in low spots will often return all at once during periods of high refrigerant velocity.
- Excess oil in the system/reservoir.
- Oil transferring through the equalizer line.



Parker Hannifin Corporation

Sporlan Division

206 Lange Drive • Washington, MO 63090 USA

phone 636 239 1111

fax 636 239 9130

www.sporlan.com