

TEMPERATURE CONTROLLER

Installation and Servicing Instructions

The Temperature Controller was designed as a simple and economical means of controlling an Electric Evaporator Pressure Regulator Valve or Electric Hot Gas Bypass Valve on almost any refrigeration or air conditioning system. A complete package of valve, controller and temperature sensor can be supplied by Sporlan Valve. Onboard readouts show actual temperature and temperature set point. Two push buttons are provided on the board to change the temperature set point.

INSTALLATION

When handling the boards, electrostatic protection procedures should be followed. The installer should be grounded through a ground strap. If ground straps or other ESD protection is not available, **ONLY** handle the board by its edges or by the battery holders. **DO NOT TOUCH ANY COMPONENTS ON THE BOARD EXCEPT THE BATTERY HOLDER OR RELAYS.**

1. The board should be mounted in a dry, protected environment using the mounting holes in each corner. Make sure none of the printed circuit paths or components are touching the metal panel or anything else conductive.
2. Controllers are configured for temperature.
3. The temperature sensor should be mounted at the point to be controlled. This may be in the air to the evaporator, the air off the evaporator or the suction line. The sensor connections to the board are at terminals labeled **TS2**.
4. **DI1** is a digital input used as a pumpdown terminal. A short or closed contact from an external relay will close the valve for pumpdown. When the relay opens or the short is removed the valve will return to normal operation.
5. Power is connected to the terminal marked **24 VAC**. Power requirements are 24 volts AC at 40 VA. For protection from electrical transients, connect one MOV surge suppressor between one leg of the input voltage of the 24 VAC transformers and earth ground. Connect a second MOV surge suppressor between the other leg of the input voltage of the 24 VAC transformer to earth ground. The recommended part number for a MOV is as follows:
 Manufacturer: Harris Semiconductor
 Part number: 120 VAC input - V150LA20A
 208/240 VAC input - V275LA20A

OPERATION

When first powered up the numeric display will show actual temperature.

1. The small green LED will be lit.
2. The red LED is the negative sign. If on, the temperature displayed is between -50 to 0°F. If the red LED is off, the temperature displayed is between 0 to 100°F.
3. To change set point for temperature:
 Press and hold PB1 and PB2 for 8 seconds, the green LED will flash rapidly.
 Use PB1 to increment set point.
 Use PB2 to decrement set point.
 The new setpoint will be locked in after about 8 seconds and the green LED will stop flashing.

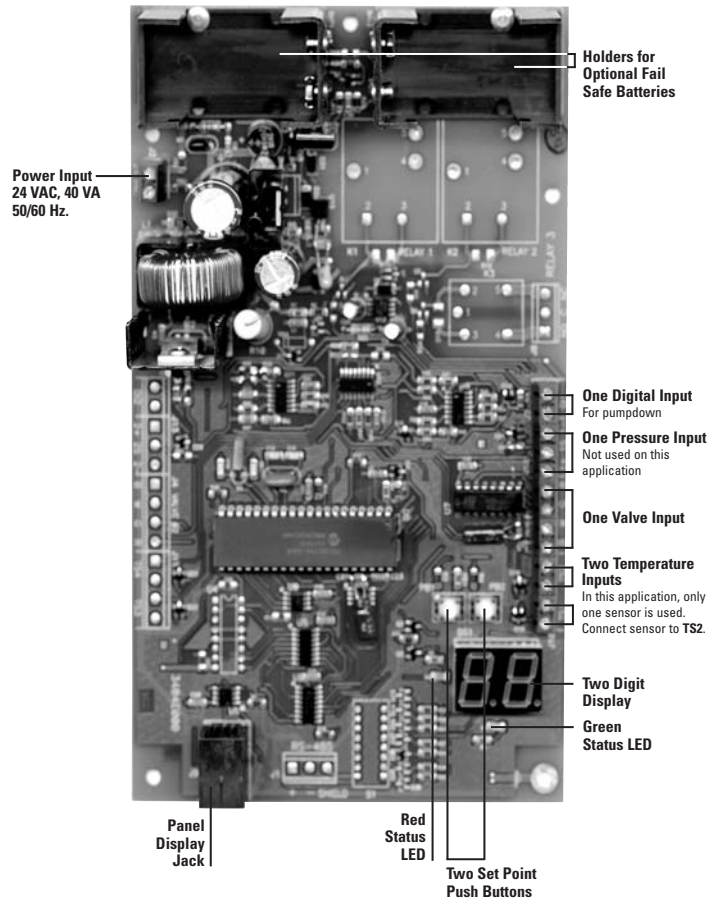

Figure 1
Temperature Controller

REMOTE PANEL DISPLAY

A remote panel display is available that will allow access to all the controller parameters. The remote panel display can be used as a set point tool in production, a diagnostic tool in the field or as a permanent readout device on the controller. A five-foot cable is included.

Plug the remote display into the telephone jack (J9) on the controller. The following is a list of readings available:

- TEMP** Temperature read by the sensor (-50 to 102°F.)
- POSN** Number of steps valve is open (0-6386)
- ACON, PMDN**
 ACON when in normal operation, PMDN when in pumpdown
- OPTR, CLTR**
 OPTR (open on temperature rise) valve will open when temperature is above set point. CLTR (close on temperature rise) valve will close when temperature is above set point.
- TMSP** Temperature set point (-40 to 103°F). Default is 35°F.
- CALT** Calibrate temperature sensor
- GAIN** Proportional gain of the controller. The number of steps the valve will move for each degree (5 to 200 steps per degree temperature is from set point) Default is 40 steps per degree.
- INTG** Integral set point. Number of seconds between updates to the reference valve position. (1 to 120 seconds). Default is 40 seconds.
- MXST** Maximum number of steps the controller will allow the valve to open (0 to 6386). Default is 6386 steps.

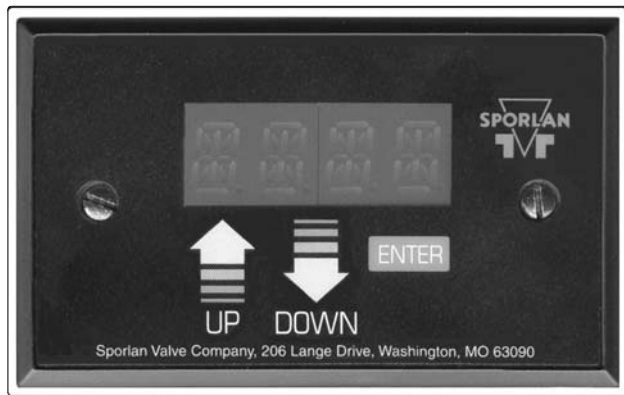

Figure 2

CONTROLLER MENUS

ENTER will toggle display between one of the displays described on page 1 and the numeric value read for that particular display. Pressing **UP** will scroll through the menu from **TEMP** to **POSN**, etc. Pressing **DOWN** will scroll through the menu the opposite way.

POSN MODE

Press and hold **UP** button and **ENTER** button simultaneously for 5 seconds to put the controller in manual valve position. The number of steps open will be displayed and the 1000's digit will blink.

Pressing the **UP** button will open the valve 1000 steps.
Pressing the **DOWN** button will close the valve 1000 steps.
Pressing the **ENTER** button will change the flashing digit from 1000's digit to the 100's digit.

Pressing the **UP** button will open the valve 100 steps.
Pressing the **DOWN** button will close the valve 100 steps.
Pressing the **ENTER** button will change the flashing digit from 100's digit to the 10's digit.

Pressing the **UP** button will open the valve 10 steps.
Pressing the **DOWN** button will close the valve 10 steps.
Pressing the **ENTER** button will change the flashing digit from 10's digit to the 1's digit.

Pressing the **UP** button will open the valve 1 step.
Pressing the **DOWN** button will close the valve 1 step.
Pressing the **ENTER** button will change the flashing digit from 1's digit to the 1000's digit.

Press and hold **UP** button and **ENTER** button together for 5 seconds to put the controller in normal control. The digits will stop blinking.

OPTR or CLTR MODE

Press and hold **UP** button and **ENTER** button for 5 seconds to enable this set point to be changed. All 4 digits will blink.

Pressing either the **UP** button or the **DOWN** button will toggle the display between **OPTR** and **CLTR**.

To lock in the new setpoint, press and hold **UP** button and **ENTER** button for 5 seconds. The digits will stop blinking.

TMSP MODE

Press and hold **UP** button and **ENTER** button for 5 seconds to enable the temperature set point to be changed. The set point is displayed and the 100's digit will blink.

Pressing the **UP** button will increase the set point by 100°F.
Pressing the **DOWN** button will decrease the set point by 100°F.

Pressing the **ENTER** button will change the flashing digit from 100's digit to the 10's digit.

Pressing the **UP** button will increase the set point by 10°F.

Pressing the **DOWN** button will decrease the set point by 10°F.

Pressing the **ENTER** button will change the flashing digit from 10's digit to the 1's digit.

Pressing the **UP** button will increase the set point by 1°F.

Pressing the **DOWN** button will decrease the set point by 1°F.

Pressing the **ENTER** button will change the flashing digit from 1's digit to the 100's digit.

Press and hold **UP** button and **ENTER** button for 5 seconds to save the set point. The digits will stop blinking.

CALT MODE

The numeric display shows the number of degrees to be either added or subtracted from the sensor, depending if the reading is negative or positive.

Press and hold **UP** button and **ENTER** button for 5 seconds to enable the sensor to be calibrated. The **CAL** number is displayed and the 10's digit will blink.

Pressing the **UP** button will increase the CAL number by 10°F.

Pressing the **DOWN** button will decrease the CAL number by 10°F.

Pressing the **ENTER** button will change the flashing digit from 10's digit to the 1's digit.

Pressing the **UP** button will increase the CAL number by 1°F.

Pressing the **DOWN** button will decrease the CAL number by 1°F.

Pressing the **ENTER** button will change the flashing digit from 1's digit to the 0.1's digit.

Pressing the **UP** button will increase the CAL number by 0.2°F.

Pressing the **DOWN** button will decrease the CAL number by 0.2°F.

Pressing the **ENTER** button will change the flashing digit from 0.1's digit to the 10's digit.

Press and hold **UP** button and **ENTER** button for 5 seconds to save the CAL number. The digits will stop blinking.

GAIN MODE

The numeric display shows the proportional gain of the controller or the number of steps the valve is moved open or closed per number of degrees F. the temperature is from the set point. The **GAIN** can be changed from 5 to 200 steps per degree F. from the set point.

Press and hold **UP** button and **ENTER** button for 5 seconds to enable the GAIN to be changed. The GAIN is displayed and the 100's digit will blink.

Pressing the **UP** button will increase the set point by 100.

Pressing the **DOWN** button will decrease the set point by 100.

Pressing the **ENTER** button will change the flashing digit from 100's digit to the 10's digit.

Pressing the **UP** button will increase the set point by 10.

Pressing the **DOWN** button will decrease the set point by 10.

Pressing the **ENTER** button will change the flashing digit from 10's digit to the 1's digit.

Pressing the **UP** button will increase the set point by 1.

Pressing the **DOWN** button will decrease the set point by 1.

Pressing the **ENTER** button will change the flashing digit from 1's digit to the 100's digit.

Press and hold **UP** button and **ENTER** button for 5 seconds to save the gain. The digits will stop blinking.

INTG MODE

Press and hold **UP** button and **ENTER** button for 5 seconds to enable the integral set point to be changed. The set point is displayed and the 100's digit will blink.

Pressing the **UP** button will increase the set point by 100 seconds.
 Pressing the **DOWN** button will decrease the set point by 100 seconds.
 Pressing the **ENTER** button will change the flashing digit from 100's digit to the 10's digit.

Pressing the **UP** button will increase the set point by 10 seconds.
 Pressing the **DOWN** button will decrease the set point by 10 seconds.
 Pressing the **ENTER** button will change the flashing digit from 10's digit to the 1's digit.

Pressing the **UP** button will increase the set point by 1 second.
 Pressing the **DOWN** button will decrease the set point by 1 second.
 Pressing the **ENTER** button will change the flashing digit from 1's digit to the 100's digit.

Press and hold **UP** button and **ENTER** button together for 5 seconds to save the set point. The digits will stop blinking.

MXST MODE

The numeric display shows the maximum number of steps the controller will allow the valve to open (0 to 6386). Default is 6386 and should not be changed except if using SDR-3 or SDR-3X. Use 3198 for SDR-3 and SDR-3X.

Press and hold **UP** button and **ENTER** button for 5 seconds to enable the set point to be changed. The set point is displayed and the 1000's digit will blink.

Pressing the **UP** button will increase the set point by 1000.
 Pressing the **DOWN** button will decrease the set point by 1000.

Pressing the **ENTER** button will change the flashing digit from 1000's digit to the 100's digit.

Pressing the **UP** button will increase the set point by 100.
 Pressing the **DOWN** button will decrease the set point by 100.
 Pressing the **ENTER** button will change the flashing digit from 100's digit to the 10's digit.

Pressing the **UP** button will increase the set point by 10.
 Pressing the **DOWN** button will decrease the set point by 10.
 Pressing the **ENTER** button will change the flashing digit from 10's digit to the 1's digit.

Pressing the **UP** button will increase the set point by 1.
 Pressing the **DOWN** button will decrease the set point by 1.
 Pressing the **ENTER** button will change the flashing digit from 1's digit to the 1000's digit.

Press and hold **UP** button and **ENTER** button for 5 seconds to save the set point. The digits will stop blinking.

Part Number	Application	Default Valve*
952812	Fahrenheit	CDS-9
952813	Celcius	SDR-4

* Default valve type may be changed. Use OPTR for CDS Evaporator Pressure Regulators and CLTR for SDR Discharge Regulators.

APPLICATIONS

Temperature Controller and an Electric Evaporator Pressure Regulator Valve

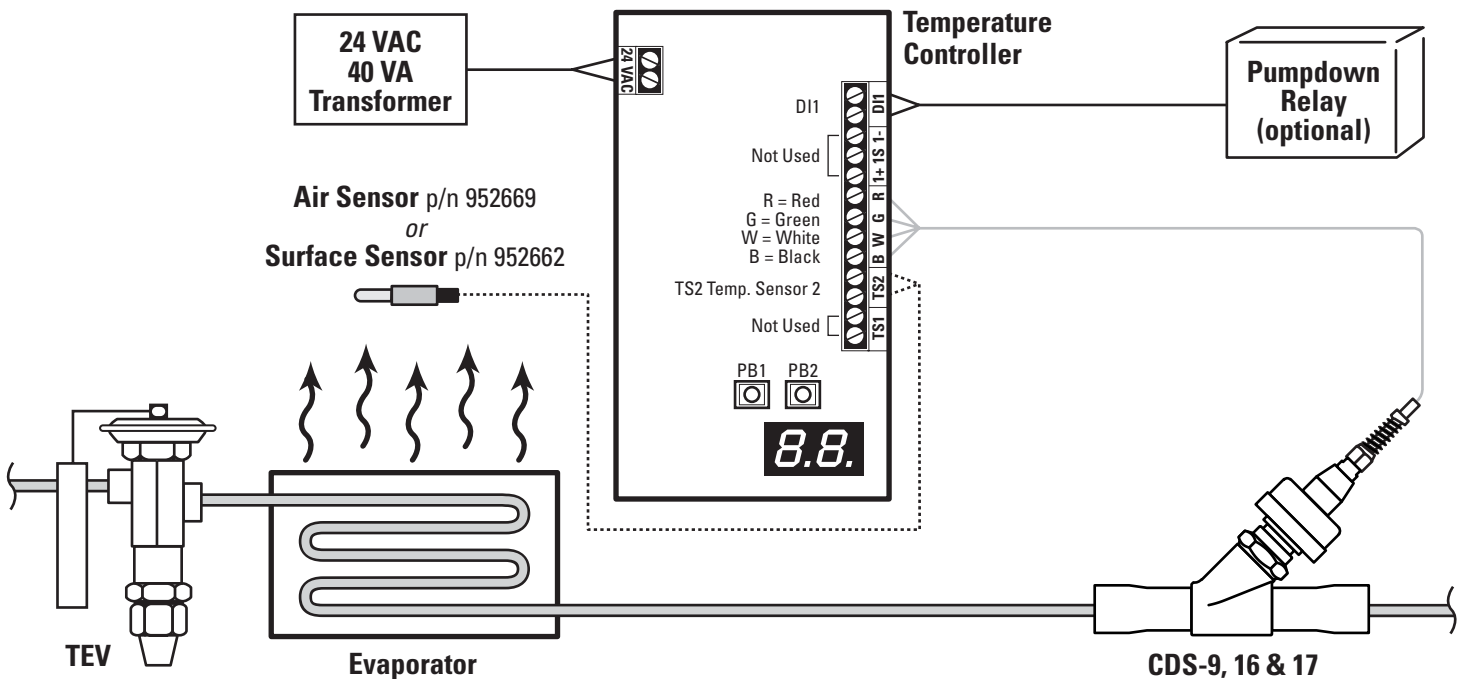

Figure 3

Temperature Controller and an Electric Hot Gas Bypass Valve

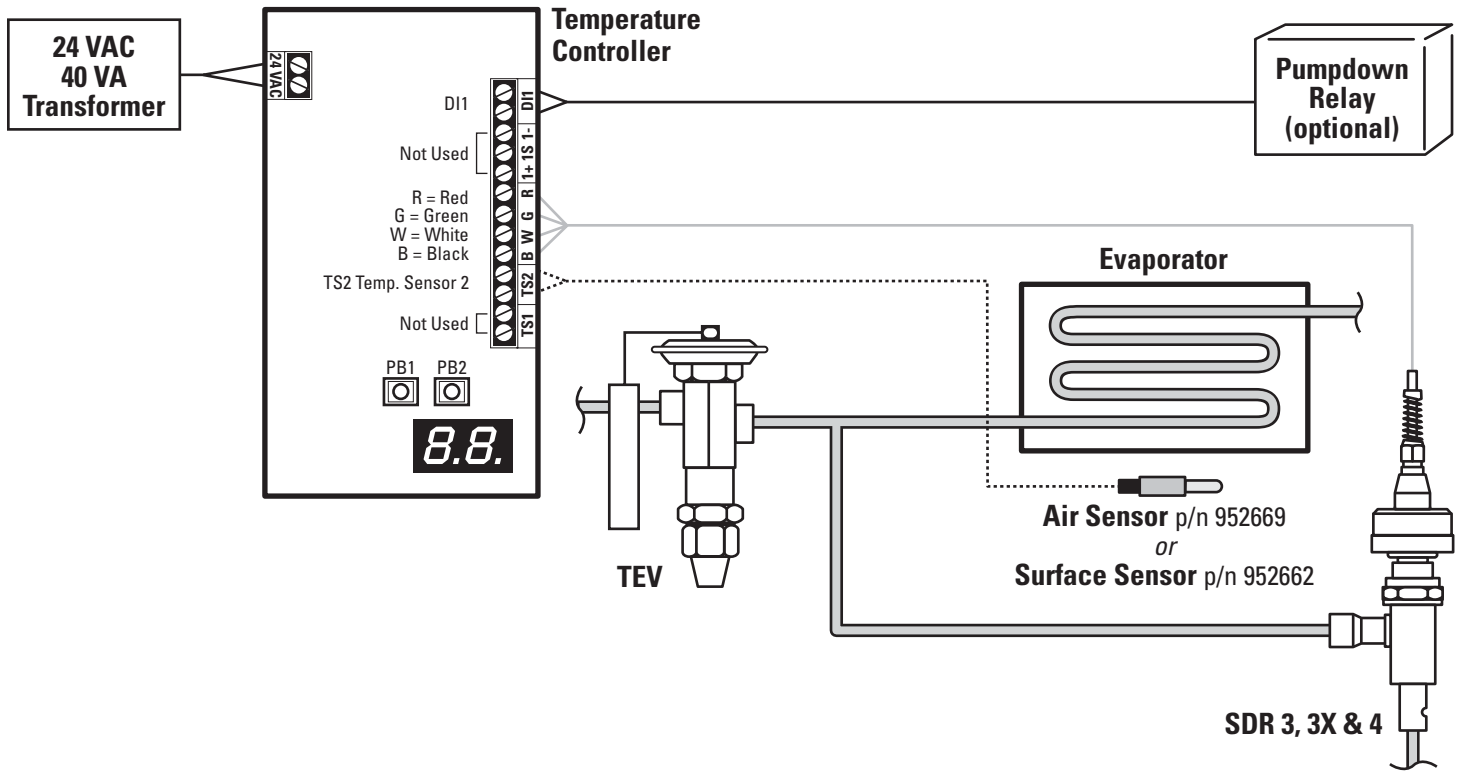

Figure 4