

Modular systems drives

AC890 systems drive

0.55kW - 1200kW

Description

The AC890 is a compact, modular systems drive engineered to control speed and position of open-loop and closed-loop, single- or multi-motor AC or servo motor applications.



Features

The AC890 can be configured for 4 different modes of operation

Open-loop (volts / frequency) control

This mode is ideal for basic, single or multi-motor speed control.

Sensorless vector control

With its ultra high performance sensorless vector algorithm, the AC890 delivers a combination of both high torque and close speed regulation without the need for any speed measuring transducer.

Closed-loop vector control

Full closed-loop flux vector performance can be achieved with the AC890 by simply adding an encoder feedback 'technology box'. This provides 100% continuous full load standstill torque, plus a highly dynamic speed loop more than sufficient for the most demanding applications.

4 Quadrant active front-end power supply module

With this configuration, the energy is fed back into the mains supply with sinusoidal currents and unity power factor; a very low current harmonic content is achieved (THD < 5%).

Compatible with a wide range of feedback options

The AC890 is compatible with any AC motor and virtually any speed/position feedback options. With this flexibility you may not even need to replace your existing AC motor to achieve high performance, saving you time and money.

- Incremental encoder
- EnDat 2.1 (SinCos) encoder
- Resolver

International standards

Complies with :

- EN61800-3 (EMC) directive
- CE marked to EN50178 (Low Voltage) directive
- UL Listed to US safety standard UL508C



Demanding environments

For environments that have dusty, humid or corrosive atmospheres, the AC890 can optionally be supplied with conformally coated circuit boards that improve the drives resistance to corrosion, thereby increasing reliability and service life.

Industries that would typically benefit from conformal coating could include :

- **Water and wastewater**
- **Paper and pulp processing**
- **Steel**
- **Marine and offshore**
- **Outdoor cranes**
- **Wind & wave power generation**
- **Food processing.**

4



AC Modular system drives

AC890 series

A High performance design



* Stand alone version shown

Features

High speed feedback

- Incremental encoder
- EnDat® 2.1 (SinCos) encoder
- Resolver

Open FireWire

IEEE 1394 process port

- 125µs Cycle time
- Real-time synchronization between drives



Open communications

EtherNet/IP
CONFIDANCE TESTED

ControlNet
CONFIDANCE TESTED

PROFIBUS

DeviceNet
CONFIDANCE TESTED

CANopen

Ultra-fast control loops

- Torque loop: 62.5µs
- Speed loop: 62.5µs
- Position loop: 62.5µs

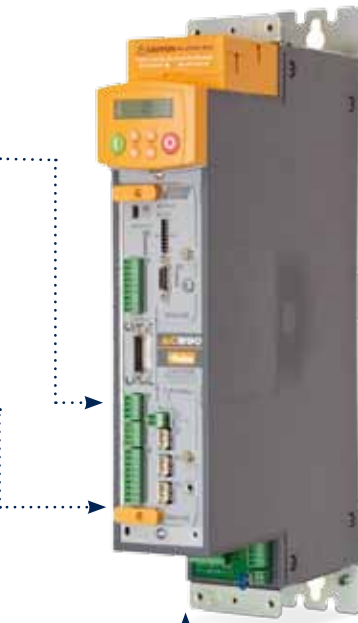

Benefits

Minimal delay between the fieldbus setpoints and the control loops

Designed to integrate in existing automation systems, the AC890 features high performance ports linked directly to the fast control loops of the drive.

Minimum delay exists between your digital setpoint sent through a fieldbus and the control loops.

Replacement of analogue solutions

Your existing analogue setpoint-based solutions can be replaced by a digital fieldbus-based solution with minimal bandwidth loss.

Flexible feedback

The AC890 offers system designers complete flexibility in their choice of feedback technology.

Open standards for protection of investment

The AC890 has been deliberately designed to integrate seamlessly into your automation network.

To connect to your PLC or fieldbus network you can simply choose from the wide range of communication technology boxes.

Serves the most demanding applications

Taking advantage of leading edge control algorithms running on a fast 150Mhz microprocessor, the AC890 drive can achieve very high-bandwidth control loops.

This allows you to use the drive for the most demanding industrial applications e.g. printing, cut-to-length, rotary shear, converting and slitting.

Two performance level options for your needs :

Advanced performance

Motion control with added position loop, motion control function blocks, move incremental, move absolute, move home, line drive master ramp and section control, winder blocks (speed winder, current winder), full function PID, machine state and others.

High performance

All advanced features plus : Library of pre-engineered application specific LINK VM function blocks such as : Shaftless Printing, cut-to-length, advanced winding, advanced traversing and others.

Modular systems drives

AC890 systems drive

Space saving compact footprint thanks to modular design concept

Stand Alone version



The complete drive

The AC890SD series Stand Alone drive provides a complete AC input to AC motor output, with power input and output terminals.

Other characteristics of the AC890SD include:

- Power output up to 900kW
- 208-500 VAC input supply
- access to all feedback and networking options
- Built-in dynamic brake switch provisions to add external braking resistor
- 24Vdc control board supply for programming without power
- torque and speed outputs
- USB programming port

Common Bus version



Common bus drive

The AC890 is also available in a common bus platform, where individual motor output drives are easily connected to a common bus supply.

Characteristics of the common bus drive (AC890CD) :

- Power output to 900kW (1200HP) in 9 frame sizes
- Power Supply : 320 to 705 VDC
- Access to all feedback and networking options
- 24VDC control board supply for programming without power
- Torque and speed analogue outputs
- USB programming port

Characteristics of the common bus supply module (AC890CS) :

- Power output 7.5 to 110kW
- Power Supply : 208-500 VAC
- Built-in dynamic braking unit (external braking resistor required)
- Operator display for diagnostics
- Up to 162A output per module

Removable terminal block connections for easier installation and maintenance



Reduced dimensions, compact footprint

The AC890 has been designed to be compact and require the minimum possible cabinet space. Boasting the latest innovations in semiconductor cooling the AC890 is a class leader in terms of its size.

The control terminals are pluggable, simplifying connection to the drive during installation and allowing a fast swap-out for maintenance purposes.

The common DC bus also helps to keep the overall size of the system to a minimum. Simply open the bus terminal cover, connect the busbars and close.

Fast connection of the common DC bus



Modular systems drives

AC890 systems drive

Active front end

4 Quadrant active front-end power supply

with regeneration to the supply network

The AC890CD and AC890SD can be configured to feed energy back into the mains supply with sinusoidal currents and unity power factor; with very low levels of harmonic current distortion.

Required parts

Pre-load circuit

LCL filter

Fully bidirectionnel power flow

150% overload for 60 sec

Sinusoidal input current

Harmonic levels meet requirements of IEEE 519

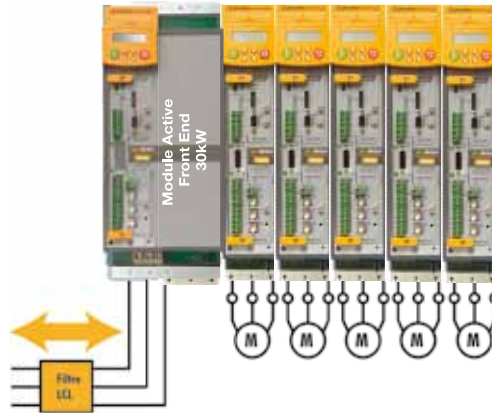

Note :

It is possible to use a larger separate active front-end module for higher power AC890 systems. In this case, several AC890's can be connected to the AFE using the AC890CA common bus adaptor.

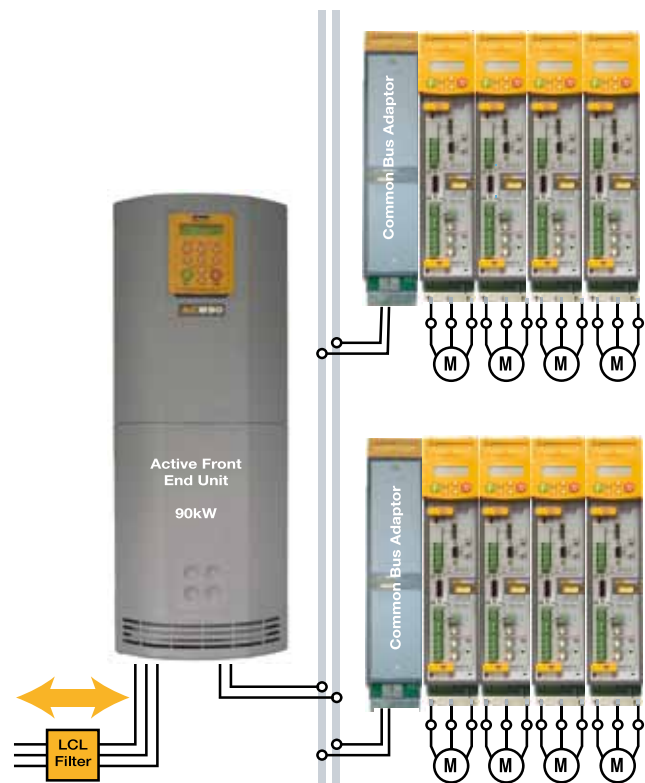
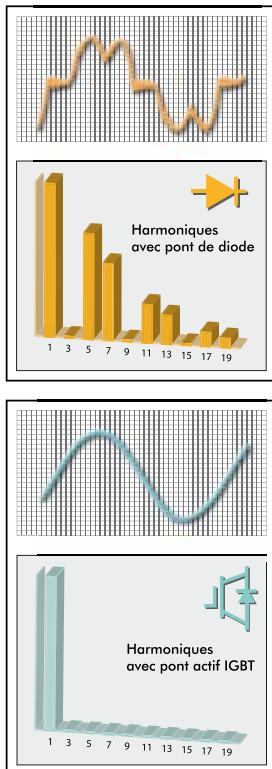

DC system power supply unit

AC890CS series

40A - 200A



Description

The AC890CS power module is able to provide dual output voltages to power one or more AC890CD or stand alone AC890SD drives connected to a common DC bus. This modularity provides significant space saving in the enclosure.

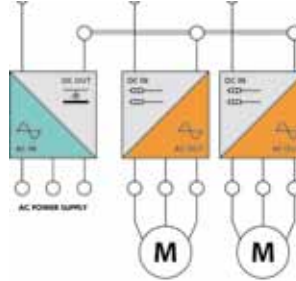

- Power Supply 208-500Vac**
- Built-in dynamic braking unit**
- Dual DC bus power output terminals**
- Operator display for diagnostics.**

- “Drive Healthy” contact**
- 24Vdc auxiliary supply (optional)**
- HMI Interface**
- Power supply selector**
- Configurable analogue outputs**

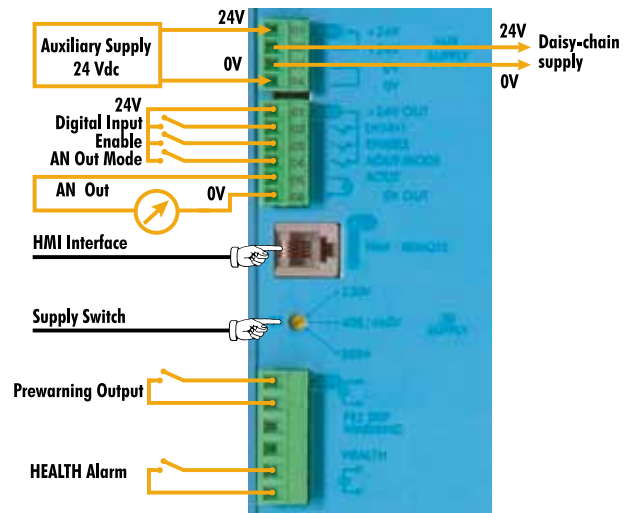

4

Electrical characteristics - AC890CS drives

Old order reference**	New order reference	Frame	Input voltage (Vac)	Power (kW)	AC input current (A)	DC output current (A)
890CS5-0032B-B	890CS-532320B0-000-U	Frame B	230	7.5	32	40
			400 / 460	15		
			500	18		
890CS5-0054B-B	890CS-532540B0-000-U	Frame B	230	15	54	65
			400 / 460	30		
			500	37		
890CS5-0108D-D	890CS-533108D0-000-U	Frame D	230	30	108	135
			400 / 460	60		
			500	75		
890CS5-0162D-D	890CS-533162D0-000-U	Frame D	230	45	162	200
			400 / 460	90		
			500	110		

Note: For increased power, additional units can be connected in parallel. For further details, contact our technical support department
 ** Old reference refers to legacy part references prior to 2009

Modular AC systems drives

AC890CD series systems drive

1.5A - 180A



Power supply 320, 650, 705Vdc

Operator display supplied as standard

Common options as AC890SD

**Fiedlbus options : Profibus, DeviceNet,
ControlNet, CANOpen**

Electrical characteristics - AC890CD drive

Old order reference**	New order reference	Frame	Input Voltage (Vdc)	Power (kW)	DC input current (A)	Output current (A)	
						Vector mode	Servo mode
890C2-0003B-B0x	890CD-231300B0-000-...	Frame B	320	0.55	4.2	3	2.2
890C2-0005B-B0x	890CD-231550B0-000-...			1.1	7.6	5.5	4
890C2-0007B-B0x	890CD-231700B0-000-...			1.5	9.3	7	6
890C2-0011B-B0x	890CD-232110B0-000-...			2.2	14.9	11	8
890C2-0016B-B0x	890CD-232165B0-000-...			4	22.2	16.5	12
890C4-0002B-N0x	890CD-531200B0-000-...			0.55	2.9	2	1.5
890C4-0003B-N0x	890CD-531350B0-000-...		1.1	5	3.5	2.5	
890C4-0004B-N0x	890CD-531450B0-000-...		1.5	6.6	4.5	3.5	
890C4-0006B-N0x	890CD-531600B0-000-...		2.2	8.6	6	4	
890C4-0010B-N0x	890CD-532100B0-000-...		4	14.1	10	6	
890C4-0012B-N0x	890CD-532120B0-000-...		5.5	16.8	12	9	
890C4-0016B-N0x	890CD-532160B0-000-...		7.5	22.2	16	12	
890C2-0024C-B0x	890CD-232240C0-000-...	Frame C	320	5.5	31	24	24
890C2-0030C-B0x	890CD-232300C0-000-...			7.5	39	30	30
890C4-0024C-N0x	890CD-532240C...		560	11	33	24	20
890C4-0030C-N0x	890CD-532300C...			15	43	30	25
890C4-0039D-N0x	890CD-532390D0-000-...	Frame D	560	18.5	37	39	35
890C4-0045D-N0x	890CD-532450D0-000-...			22	43	45	38
890C4-0059D-N0x	890CD-532590D0-000-...			30	59	59	50
890C4-0073E-N0x	890CD-432730E0-0...	Frame E	560	37	82	73	55
890C4-0087E-N0x	890CD-432870E0-0...			45	100	87	65
890C5-0073E-N0x	890CD-532730E0-0...		705	37	66	67	Data not available*
890C5-0087E-N0x	890CD-532870E0-0...			45	80	79	
890C4-0105F-N0x	890CD-433105F...	Frame F	560	55	123	105	78
890C4-0145F-N0x	890CD-433145F...			75	166	145	108
890C4-0156F-N0x	890CD-433156F...			90	203	180	135
890C4-0180F-N0x	890CD-433180F...			90	203	180	Data not available*
890C5-0105F-N0x	890CD-533105F...		705	55	98	100	
890C5-0145F-N0x	890CD-533145F...			75	133	125	
890C5-0156F-N0x	890CD-533156F...			90	162	156	

x : Version "A" (Advanced) or "H" (High performance)

* For future developments, please contact us or visit our website www.parker.com/ssd

Note : For higher powers, refer to AC890SD series supplied from a DC bus.

Note : Power ratings are given for 320 and 560Vdc

** Old reference refers to legacy part references prior to 2009

Modular AC systems drives

AC890SD series systems drive

1.5A - 1681A



Description

The AC890SD (Standalone) drives are independent modules with integrated three-phase supply inputs. With its wide range of sizes available, the AC890SD is suitable for every type of application from a small machine to a large industrial high power process line (eg rolling mill). It is also suitable for applications requiring sectional control and assembly of independent modules (eg printing systems).

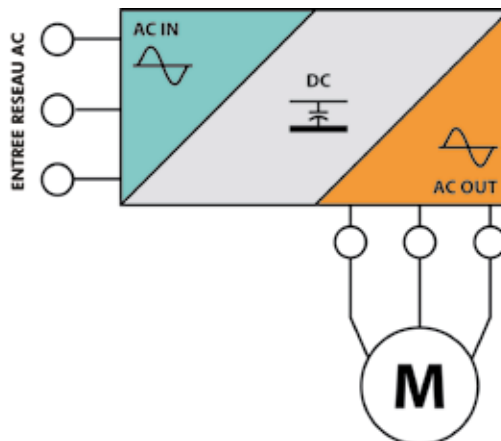

- Directly supplied AC or DC common bus**
- Built-in dynamic braking module**
- Operator display fitted as standard**
- Common options as AC890CD**
- Fieldbus options: Profibus, DeviceNet, ControlNet, CANOpen**

4

Electrical characteristics - AC890SD drive - 230V

Old order reference**	New order reference	Frame	Input voltage (Vac)	Power (kW)	Input current (A)		Output current (A)	
					Vector mode	Servo mode	Vector mode	Servo mode
890D2-0003B-B0x	890SD-231300B0-B00-...	Frame B	230	0.55	4.2	4.2	3	2.2
890D2-0005B-B0x	890SD-231550B0-B00-...			1.1	7.7	7.3	5.5	4
890D2-0007B-B0x	890SD-231700B0-B00-...			1.5	9.3	9.9	7	6
890D2-0011B-B0x	890SD-232110B0-B00-...			2.2	15.2	12.9	11	8
890D2-0016B-B0x	890SD-232165B0-B00-...			4	21.8	18.2	16.5	12
890D2-0024C-B0x	890SD-232240C0-B00-...	Frame C	230	5.5	31	31	24	24
890D2-0030C-B0x	890SD-232300C0-B00-...			7.5	40	40	30	30

x : Version "A" (Advanced) or "H" (High performance)

Note : Power ratings are given for 230Vac

Permitted overload : 150% for 60 sec in vector mode - 200% for 4 sec in servo mode.

** Old reference refers to legacy part references prior to 2009

Electrical characteristics - AC890SD drive (contd.)

Old order reference**	New order reference	Frame	Input voltage (Vac)	Power (kW)	Input current (A)		Output current (A)	
					Vector mode	Servo mode	Vector mode	Servo mode
890D4-0002B-BOx	890SD-531200B0-B00-...	Frame B	380-500	0,55	2,9	2,9	2	1,5
890D4-0003B-BOx	890SD-531350B0-B00-...			1,1	5	4,7	3,5	2,5
890D4-0004B-BOx	890SD-531450B0-B00-...			1,5	6,8	6,4	4,5	3,5
890D4-0006B-BOx	890SD-531600B0-B00-...			2,2	9	7,2	6	4
890D4-0010B-BOx	890SD-532100B0-B00-...			4	14	14	10	6
890D4-0012B-BOx	890SD-532120B0-B00-...			5,5	16,5	13,8	12	9
890D4-0016B-BOx	890SD-532160B0-B00-...			7,5	21,7	17,9	16	12
890D4-0024C-BOx	890SD-232240C0-B00-...	Frame C	380-500	11	32	32	24	20
890D4-0030C-BOx	890SD-232300C0-B00-...			15	40	40	30	25
890D4-0039D-BOx	890SD-532390D0-B00-...	Frame D	380-500	18,5	42	38	39	35
890D4-0045D-BOx	890SD-532450D0-B00-...			22	50	45	45	38
890D4-0059D-BOx	890SD-532590D0-B00-...			30	62	54	59	50
890D4-0073E-BOx	890SD-432730E0-0...	Frame E	380-460	37	81	81	73	73
890D4-0087E-BOx	890SD-432870E0-0...			45	95	95	87	87
890D4-0105F-BOx	890SD-433105F...	Frame F	380-460	55	114	114	105	78
890D4-0145F-BOx	890SD-433145F...			75	143	143	145	110
890D4-0156F-BOx	890SD-433156F...			90	164	164	180	135
890D4-0216G-BOx	890SD-433216G...	Frame G	380-460	110	216	Data not available*	216	151
890D4-0250G-BOx	890SD-433250G...			132	246		250	175
890D4-0316G-BOx	890SD-433316G...			160	305		316	221
890D4-0361G-BOx	890SD-433361G...			180	336		361	257
890D4-0375H-BOx	890SD-433375H...	Frame H	380-460	200	367	Data not available*	375	262
890D4-0420H-BOx	890SD-433420H...			220	400		420	294
890D4-0480H-BOx	890SD-433480H...			250	466		480	336
890D4-0520H-BOx	890SD-433520H...			280	516		520	364
890D4-0590J-BOx	890SD-433590J...	Frame J	380-460	315	576	Data not available*	590	413
890D5-0073E-BOx	890SD-532730E0-0...	Frame E	380-500	37	69	69	66	66
890D5-0087E-BOx	890SD-532870E0-0...			45	82	82	79	79
890D5-0105F-BOx	890SD-533105F...	Frame F	380-500	55	93	93	100	74
890D5-0145F-BOx	890SD-533145F...			75	118	118	125	95
890D5-0156F-BOx	890SD-533156F...			90	140	140	156	117
890SD/5/0685K/ * /1F/A/US	890SD/5/0685K/ * /1F/A/US			K(2xG)	380-460	355	Data not available*	Data not available*
890SD/5/0798K/ * /1F/A/US	890SD/5/0798K/ * /1F/A/US	K(2xH)	400	798		570		
890SD/5/0988K/ * /1F/A/US	890SD/5/0988K/ * /1F/A/US	K(2xH)	500	1028		720		
890SD/5/1028K/ * /1F/A/US	890SD/5/1028K/ * /1F/A/US	K(3xG)	600	988		699		
890SD/5/1120K/ * /1F/A/US	890SD/5/1120K/ * /1F/A/US	K(2xJ)	550	1120		780		
890SD/5/1197K/ * /1F/A/US	890SD/5/1197K/ * /1F/A/US	K(3xH)	630	1197		855		
890SD/5/1482K/ * /1F/A/US	890SD/5/1482K/ * /1F/A/US	K(3xH)	800	1482		1049		
890SD/5/1681K/ * /1F/A/US	890SD/5/1681K/ * /1F/A/US	K(3xJ)	900	1681		1171		

x : Version "A" (Advanced) or "H" (High performance)
 * For future developments please contact us, or visit our website
 Note : Power ratings are given for 400Vac.
 ** Old reference refers to legacy part references prior to 2009

Permitted overload : 150% for 60 sec in vector mode
 200% for 4 sec in servo mode (Frames B,C,D)
 150% for 60 sec in servo mode (Frames E, F, G, H, J)

Modular AC systems drives

AC890 alternative input power configurations

1.5A - 1681A

The modular design of the AC890 makes it easy to connect parallel input modules and multi-phase configurations. By using 12-pulse or 18-pulse configurations, harmful line harmonics can be greatly reduced. For the ultimate in harmonic abatement, an Active Front End (AFE) may be selected.



6 pulse Model	Power rating	Constant torque : 355 - 900 kW Variable torque : 400 - 1000 kW
	Supply voltage	380-460Vac (±10%) 3-phase
	Disconnect switch	Standard
	Input inductance	Standard for limiting harmonic current
	Output choke	Standard
	Operator panel	6901 operator keypad mounted on enclosure door
12 pulse model (optional)	Harmonics	Reduced harmonic current
	Power rating	Constant torque : 355 - 600 kW Variable torque : 400 - 650 kW
	Supply voltage	380-460Vac (±10%) 3-phase
	Disconnect switch	Standard
	Input transformer	(not included in the enclosure) optional 2 secondaires U/D
	Output choke	Standard
18 pulse model (option)	Harmonics	Total harmonic distortion (current) in accordance with limits of IEEE 519 (1992)
	Power rating	Constant torque : 630 - 900 kW Variable torque : 750 - 1000 kW
	Supply voltage	380-460Vac (±10%) 3-phase
	Disconnect switch	Standard
	Input transformer	(not included in the enclosure) optional 3 secondaires phase shifted by 20°
	Output choke	Standard
Operator panel	6901 operator keypad mounted on enclosure door	

4

Standards

The AC890 series meets the following standards when installed in accordance with the relevant product manual.

CE marked to EN50178 (safety, low voltage directive)

CE marked to EN61800-3 (EMC directive)

UL listed to US safety standard L508C.

cUL listed to Canadian standard C22.2 #14.



Valid at time of print.



Dimensions

AC890 series systems drives

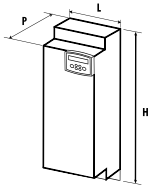

Frames B/C/D

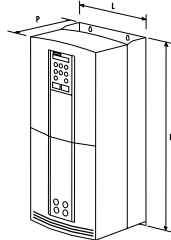

Frames E/F

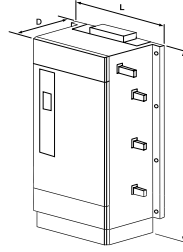

Frames G/H/J

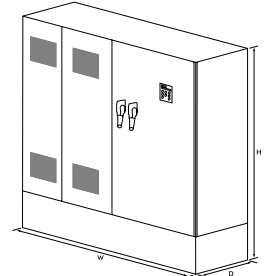

Frame K

Dimensions and weights

Model	W (mm)	H (mm)	D (mm)	Weight (kg)			
				890CS	890CD	890SD	
890 Frame B	72.4	433	258	3.5	5	6	
890 Frame C	116			Data not available	6.6	7.6	
890 Frame D	160			8.7	12.1	13.1	
890 Frame E	257	668	312	Data not available	32.5	33.5	
890 Frame F		720			41	42	
890 Frame G	456	1.042	465		Data not available	Data not available	108
890 Frame H	572	1.177					138
890 Frame J	675	1.288					176
Frame K 355/400kW*	1600	2000	600				Data not available
Frame K 400/475kW*	1600	2000	600				
Frame K 500/600kW*	1600	2000	600				
Frame K 600/650kW*	2000	2000	600				
Frame K 550/630kW*	2400	2000	600				
Frame K 630/750kW*	2400	2000	600				
Frame K 800/900kW*	2400	2000	600				
Frame K 900/1000kW*	3000	2000	600				

AC modular system drives

AC890 series

Selection and order code



AC890CS series - AC-DC for DC bus connection

		Block 1	Block 2	Block 3	Block 4
		Example ▶ 890CS	- 53 2320 B 0	- B 00	- U
Product family	AC890 Common Bus Supply Unit	890CS			
	Supply voltage	Current (A)	Frame Size		
	400/500V three-phase			53	
Current / power ratings		32	B	2320 B	
		54	B	2540 B	
		108	D	3108 D	
		162	D	3162 D	
Auxiliary supply	None		0		
Brake switch	Fitted			B	
Special option	None			00	
Language	English (50/60Hz)				U

4

AC890CA series - common bus adapter

		Block 1	Block 2	Block 3	Block 4
		Example ▶ 890CA	- 53 2500 B 0	- R 00	- U
Product family	AC890 common bus adapter	890CA			
	Supply voltage	Current (A)	Frame Size		
	400/500V three-phase			53	
Current / power ratings		50	B	2500 B	
		80	B	2800 B	
Auxiliary supply	None			0	
Hardware characteristics	None (80A only) (Ride through capacitors only (50A only)			0 R	
Special options	None			00	
Language	English (50/60Hz)				U

AC modular system drives

AC890 series

Selection and order code



AC890CD series - commun bus drive < 37kW

		Block 1	Block 2	Block 3	Block 4
		Example ▶ 890CD	- 23 1300 B 0	- B 00	- 1 A 0 0 0
Product family	Standalone AC890 drive	890CD			
Power / current ratings	230V nominal		23		
	Vector Mode				
	Servo Mode				
	kW/A	HP/A	kW/A	HP/A	Frame
	230Vca	230Vca	230Vca	230Vca	
	0.55/3.0	0.75/3.0	0.55/2.2	0.75/2.2	B
	1.1/5.5	1.5/5.5	1.1/4.0	1.5/4.0	B
	1.5/7.0	2.0/7.0	1.5/6.0	2.0/6.0	B
	2.2/11	3.0/11	2.2/8.0	3.0/8.0	B
	4.0/16.5	5.0/16.5	4.0/12	5.0/12	B
5.5/24	7.5/24	5.5/24	7.5/24	C	
7.5/30	10/30	7.5/30	10/30	C	
Power /current ratings	500V nominal		53		
	Vector Mode				
	Servo Mode				
	kW/A	HP/A	kW/A	HP/A	Taille
	400Vca	460Vca	400Vca	460Vca	
	0.55/2.0	0.75/2.0	0.55/1.5	0.75/1.5	B
	1.1/3.5	1.5/3.5	1.5/2.5	1.5/2.5	B
	1.5/4.5	2.0/4.5	1.5/3.5	2.0/3.5	B
	2.2/6.0	3.0/5.0	2.2/4.0	3.0/4.0	B
	4.0/10	5.0/8.0	4.0/6.0	5.0/6.0	B
	5.5/12	7.5/12	5.5/9.0	7.5/9.0	B
	7.5/16	10/14	7.5/12	10/10	B
	7.5/16	10/14	7.5/16	10/14	B
	11/24	15/24	11/20	15/20	C
	15/30	20/27	15/25	20/22	C
	15/30	20/30	15/30	20/28	C
	18.5/39	25/35	18.5/35	25/29	D
	22/45	30/40	22/38	30/34	D
30/59	40/52	30/50	40/45	D	
Auxiliary supply	not required (not available on frames B-E)			0	
Brake switch	Not Fitted			B	
Special options	None			00	
	Documented special options (01-99) (Refer to local sales office)				
Performance	Advanced			1	
	High			2	
Language	English (50Hz)			A	
	English (60Hz)			B	
Option F	None			0	
	SinCos Encoder (Endat 2.1)			1	
	Incremental Quadrature Encoder			3	
	Resolver			5	
	8902/M1 Sin/Cos Registration			7	
Option A	Not Fitted			0	
	CaNOpen			N	
	ControlNet			C	
	DeviceNet			D	
	Profibus			P	
	8903/M1 Sin/Cos Registration			7	
Option B	Not Fitted			0	
	Firewire 1394A			A	

AC modular system drives

AC890 series

Selection and order code



AC890CD series - common bus drive > 37kW

		Block 1	Block 2	Block 3	Block 4					
Example ▶		890CD	- 432730 E 0	- 0 00	- 1 A 0 0 0					
Product family	AC890 common bus drive	890CD								
400V nominal		43								
Power / current ratings	Induction Mode				Servo Mode				Frame	
	Constant		Quadratic		Constant		Quadratic			
	kW/A	HP/A	kW/A	HP/A	kW/A	HP/A	kW/A	HP/A		
	560Vcc	650Vcc	560Vcc	650Vcc	560Vcc	650Vcc	560Vcc	650Vcc		
	37/73	50/73	45/87	60/87	37/73	50/73	45/76	60/76		
	45/87	60/87	55/105	75/105	45/87	60/87	55/90	75/90		
	55/105	75/100	75/145	100/125	55/78	75/74	75/126	100/108		
	75/145	100/130	90/165	125/156	75/110	100/99	90/143	125/135		
	90/180	125/156	110/205	150/180	90/135	125/117	110/176	150/154		
90/180	150/180	-	-	90/135	150/135	-	-			
500V nominal		53								
Power / current ratings	Induction Mode				Servo Mode				Frame	
	Constant		Quadratic		Constant		Quadratic			
	kW/A	HP/A	kW/A	HP/A	kW/A	HP/A	kW/A	HP/A		
	705Vcc	705Vcc	705Vcc	705Vcc	705Vcc	705Vcc	705Vcc	705Vcc		
	37/67	-	45/79	-	37/67	-	45/69	-		
	45/79	-	55/98	-	45/79	-	55/84	-		
	55/100	-	75/125	100/125	55/74	-	75/93	100/93		
	75/125	-	90/156	125/156	75/95	-	90/118	125/118		
	90/156	-	-	-	90/117	-	-	-		
Auxiliary supply	Not required (Frames B-E)						0			
	115V 1-phase (Frame F only)						1			
	230V 1-phase (Frame F only)						2			
Brake switch	Not Fitted						0			
Special options	None						00			
	Active Front End ('Y' caps removed - only available on frames E-F)						07			
	Documented special options (01-99) (Refer to local sales office)									
Performance	Advanced						1			
	High						2			
Language	English (50Hz)						A			
	English (60Hz)						B			
Option F	None						0			
	SinCos encoder (Endat 2.1)						1			
	Incremental Quadrature encoder						3			
	Resolver						5			
	8902/M1 Sin/Cos Register						7			
Option A	Not Fitted						0			
	CaNOpen						N			
	ControlNet						C			
	DeviceNet						D			
	Profibus						P			
	8903/M1 Sin/Cos registration						7			
Option B	Not Fitted						0			
	Firewire 1394A						A			

4

AC modular system drives

AC890 series

Selection and order code



AC890SD series - Standalone drive < 37kW

		Block 1	Block 2	Block 3	Block 4
		Example ▶ 890SD	- 23	1300 B	0 - B 00 - 1 A 0 0 0
Product family	Standalone AC890 drive	890SD			
Power / current ratings	230V nominal	23			
	Induction Mode	Servo Mode			
	kW/A	HP/A	kW/A	HP/A	Frame
	230Vca	230Vca	230Vca	230Vca	
	0.55/3.0	0.75/3.0	0.55/2.2	0.75/2.2	B
	1.1/5.5	1.5/5.5	1.1/4.0	1.5/4.0	B
	1.5/7.0	2.0/7.0	1.5/6.0	2.0/6.0	B
	2.2/11	3.0/11	2.2/8.0	3.0/8.0	B
	4.0/16.5	5.0/16.5	4.0/12	5.0/12	B
	5.5/24	7.5/24	5.5/24	7.5/24	C
7.5/30	10/30	7.5/30	10/30	C	
Power / current ratings	500V nominal	53			
	Induction Mode	Servo Mode			
	kW/A	HP/A	kW/A	HP/A	Frame
	400Vca	460Vca	400Vca	460Vca	
	0.55/2.0	0.75/2.0	0.55/1.5	0.75/1.5	B
	1.1/3.5	1.5/3.5	1.5/2.5	1.5/2.5	B
	1.5/4.5	2.0/4.5	1.5/3.5	2.0/3.5	B
	2.2/6.0	3.0/5.0	2.2/4.0	3.0/4.0	B
	4.0/10	5.0/8.0	4.0/6.0	5.0/6.0	B
	5.5/12	7.5/12	5.5/9.0	7.5/9.0	B
	7.5/16	10/14	7.5/12	10/10	B
	7.5/16	10/14	7.5/16	10/14	B
	11/24	15/24	11/20	15/20	C
	15/30	20/27	15/25	20/22	C
	15/30	20/30	15/30	20/28	C
	18.5/39	25/35	18.5/35	25/29	D
	22/45	30/40	22/38	30/34	D
30/59	40/52	30/50	40/45	D	
Auxiliary supply	Not Required (Not available on frames B-D)			0	
Brake switch	Brake switch fitted				B
Special options	None				00
	Documented special options (01-99) (Refer to local sales office)				
Performance	Advanced				1
	High				2
Language	English (50Hz)				A
	English (60Hz)				B
F Option	None				0
	SinCos encoder (Endat 2.1)				1
	Incremental quadrature encoder				3
	Resolver				5
	8902/M1 Sin/Cos registration				7
A Option	Not Fitted				0
	CaNOpen				N
	ControlNet				C
	DeviceNet				D
	Profibus				P
	8903/M1 Sin/Cos registration				7
B Option	Not installed				0
	1394A Firewire				A

Accessories and options

AC890/AC890PX series



Options	Frame	Fitted	Reference	Page
Filter				
EMC filter	B	Option		167
Options cards				
Firewire peer-to-peer		Option	8903-FA-00	170
CAN peer-to-peer		Option	8903-CC-00	
Ethernet Modbus/TCP		Option	8903-IM-00	
Ethernet Ethernet/IP		Option	8903-IP-00	
Profinet		Option	8903-PN-00	
Profibus-DP		Option	8903-PB-00	
DeviceNet		Option	8903-DN-00	
CANopen		Option	8903-CB-00	
ControlNet		Option	8903-CN-00	
Resolver feedback		Option	8902-RE-00	
Resolver feedback with simulated incremental encoder		Option	8902-RR-00	
SinCos Endat 2.1 feedback		Option	8902-E1-00	171
Incremental quadrature encoder		Option	8902-EQ-00	
Incremental pulse encoder		Option	8902-EP-00	
SinCos Endat 2.1 feedback and registration		Option	8902-M1-00	172
SinCos Endat 2.1 master and registration		Option	8903-M1-00	
Incremental master encoder		Option	8903-EP-00	
High resolution analogue input		Option	8903-AI-00	
Accessories				
Standard compact keypad		Standard	6511-RS232-00-B	169
Alphanumeric keypad		Option	6901-00-B	
Graphical operator station		Option	6911-01-00-G	
Remote mounting kit for keypad		Option	6052-00-B	
Configuration tool software including USB cable		Option		175
System Busbars - frame B-D	B-D	Option	BH465850	169
Installation kit frame B-d	B-D	Standard	LA468430Uxx3	
Ventilation duct kit (1M exhaust for frames B,C,D)	B-D	Option	8905-DUCTKIT-190	
Ventilation fan kit frame B-D	B-D	Option	8905-DUCTFAN-190	

Accessories

AC890/AC890PX series



Keypad

Model	Description
6511-TTL-00	4 Digit LCD keypad*
6901/00	Alphanumeric multilingual keypad**
6911-01-00-G	Graphical operator station
6052/00	Remote mounting kit for 6901 with 3m cable

*Standard equipment for frames B - D

** Standard equipment for frames E - K



Screened power cables with connectors

Model	Description
CD1UA1F9R00xx	Power cable with motor connector for NX motor and $I_0 \leq 14A$ rms
CD1UP2F1R00xx	Power cable with motor connector for NX motor and $I_0 \leq 22A$ rms
CS4UA1F1R00xx	Resolver cable with motor connector and Sub-D connector for NX motor

Assembly kit

Model	Description
LA468430U003	Assembly kit for 890CS/CA
LA468430U103	Assembly kit for 890CD, B to D
LA468430U203	Assembly kit for 890SD, B to D
8905-DUCTKIT-00	Ventilation duct kit
8905-DUCTFAN-00	Ventilation duct fan

Cables

Model	Description
8905-USBCL1-00	USB programming cable for 890
8905-FWCBL200-00	FireWire cable 200 mm
8905-FWCBL280-00	FireWire cable 280 mm
8905-FWCBL1000-00	FireWire cable 1000mm
8905-FWCBL4500-00	FireWire cable 4.5 m

Busbar System

Model	Description
BH465850	DC SSD Rail/Bus Bar 140A (UL) 1m
BC465938U200	Insulator for DC bus bars 200mm

Options

AC890/890PX series

Communication interfaces



Modbus/TCP (8903-IM-00) and Ethernet IP (8903-IP-00)

Supported protocols	Card 8903-IM-00 : Modbus/TCP Card 8903-IP-00 : Ethernet IP
Communication speed	10/100M bits/s
Station Address	By Drive System Explorer software via RTNX protocol
Suitable for Drives	AC890 version 3.2+

DeviceNet (8903-DN-00)

Supported protocols	Supports the group 2 only slave subset of the DeviceNet protocol
Supported messages	Polled I/O, cyclic outputs, change of state (COS), Explicit messaging
Communication speed	125K, 250K et 500K bits/s
Station address (MACID)	Dip switch or software setting of station address and network speed
Suitable for drives	AC890 version 1.9+

CanOpen (8903-CB-00)

Profile	DS402
Supported messages	SDO, PDO, NMT, SYNC
Communication speed	20K, 50K, 125K, 250K, 500K, 1M bits/s selectable by software or dip switch setting
Station address	Dip switch or software setting of station address and network speed
Suitable for drives	AC890 version 1.3+

ControlNet (8903-CN-00)

Supported messages	Polled I/O
Station address	Selectable by software
Station address	Selectable by dip switch
Suitable for drives	AC890 version 1.4+

Profibus-DP (8903-PB-00)

Supported protocols	Profibus-DP ; demand data and data exchange
Communication speed	Up to 12M bits/s selected by the master
Station address	Dip switch or software setting of station address
Suitable for drives	AC890 version 1.4+

FireWire IEEE 1394 (8902-FA-00)

Communication Supported	peer-to-peer communication between drives
-------------------------	---

Profinet (8903-PN-00 and 8903-PN-FF)

Supported protocols	Profinet I/O RT protocol
Station address (IP)	Software setting of IP address via DSE
Suitable for drives	AC890 version 3.3+

Peer to peer (8903-SP-00 and 8903-SP-FF)

Supported protocols	Peer to peer data exchange with other drives
Communications speed	up to 1M bits/s selectable by dip switch
Suitable for drives	AC890 version 3.3+



5

Options

AC890/890PX series

Incremental quadrature encoder card 8902-EQ



Description

The HTTL 8902-EQ speed feedback option allows incremental encoders to be connected directly to the drive to provide highly accurate speed feedback measurement. Supplies variable voltage isolated encoder power supply.

Product codes

Code	Description
8902-EQ-00-00	Optional HTTL incremental encoder
8902-EQ-00-FF	Option HTTL encoder factory-fitted

Features

Maximum pulse rate	250kHz (differential) 200kHz (single ended)
Receiver current	≤10mA per channel
Input format	Two differential channels in quadrature (Clock/direction or clock only)
Input voltage	±30V (differential), 0-30V (single-ended)
Input voltage differential	±30V maximum
Input voltage threshold dip switch settings	3V ± 1V (differential) 8V ± 1V (single-ended)
Encoder power supply	Maximum load 200mA or 2W



Options

AC890/890PX series

Resolver feedback card 8902-RE



Description

The 8902-RE resolver speed feedback option allows the resolver to be connected directly to the drive to provide highly accurate speed feedback measurement. Contains a carrier output signal to power the resolver.

Product codes

Code	Description
8902-RE-00-00	Optional resolver feedback card
8902-RE-00-FF	Option resolver feedback factory-fitted

Features

Maximum speed	Up to 50 000 RPM (with 2 pole resolver)
Carrier output signal	7V rms, 8kHz
Maximum carrier supply	70mA rms
Maximum input voltage	±12V peak
Accuracy	< 5 minutes
Resolution	Equivalent to 16 bits in one revolution of resolver
Inputs	Differential inputs Zin ~2 kΩ
Maximum input voltage	12Vpeak

SinCos Endat 2.1 feedback card 8902-E1



Description

The SinCos speed feedback option 8902-E1 allows a 1V p-p Sin/Cos encoder to be connected directly to the drive to provide highly accurate speed feedback measurement. Decodes Heidenhain Endat 2.1 absolute position encoders and supplies 5V or 10V for the encoder.

Product codes

Code	Description
8902-E1-00-00	Optional SinCos encoder card
8902-E1-00-FF	Optional SinCos card factory-fitted

Features

Maximum pulse rate	250kHz
Receiver impedance	120Ω
Input format	two differential 1V p-p signals in quadrature
Encoder supply	Maximum load 250mA Adjustable Voltage 5V/10V

Options

AC890/890PX series

SinCos registration position 8902-M1 and 8903-M1



Description

The 8903-M1-00 and 8902-MA-00 feedback cards allow operation without external registration position, thanks to the connection of the encoder to the drive. They provide highly accurate speed feedback measurement and registration. Nevertheless registration applications are best achieved when both cards are used.

- Registration achieved in the drive
- Interpolates each encoder line with 11-bit accuracy giving 4 million counts / rev. on a 2048 line encoder
- Optional 1V input from 'Z' index pulse for use with registration
- Supplies 5V or 10V to the encoder
- Decodes Heidenhain Endat 2.1 absolute position encoders
- 4 optically isolated auxiliary digital outputs that can be used either for general purpose inputs, or for inputs from registration mark sensor (8903-M1 only)
- 3 non-isolated auxiliary digital outputs that can be either for general purpose outputs or for synthesizing an encoder output (8903-M1 only)

Product codes

Code	Description
8902-M1-00	Slave SinCos registration
8903-M1-00	Master SinCos registration
8902-M1-FF	Slave SinCos registration factory-fitted
8903-M1-FF	Master SinCos registration factory-fitted

Approved encoders

	1V p-p	Endat 2.1	Single Turn ABS	Multi-turn ABS
Heidenhain :				
EQN425	√	√		√
ECN413	√	√	√	
ERN480	√			
Stegmann :				
HG660 AKR (xxxx)S	√			
HG660 DKR (xxxx)S	√			
Hengstler :				
RIS58-H	√			

Specification

Encoder inputs (8902-M1... and 8903-M1...)

Maximum pulse rate	250kHz
Receiver impedance	120Ω
Input format	2 differential 1V p-p signals in quadrature
Encoder supply	250mA Maximum load
Supply voltage	5V/10V adjustable
Terminal type	Sub-D15 connector
Maximum cable length	150m screened cable
Serial protocol	Endat 2.1

Additional digital inputs (8903-M1... only)

Low logic level	0V to 5V relative to X63 pin 5
High logic level	15V to 26V relative to X63 pin 5
Absolute Max. input Voltage	30V relative to X63 pin 5
Input current	Low logic level < 1mA High logic level > 3mA, < 10mA Typical input at 24V : 7mA
Isolation withstand relative to drive chassis	30V
Input safety category	SELV
Terminal type	6-way pluggable 3.5mm terminal block
Maximum cable length	150m. screened cable is recommended for all lengths, but essential if over 30m in order to comply with EMC regulations

Auxiliary digital outputs (8903-M1... only)

Input voltage (VS)	5V to 24V
Maximum input voltage	30V
Maximum output current	± 100mA per output
Output voltage	Low logic level < 3V to 100mA High logic level > VS – 4V to 100mA
Overload and short circuit duration	Indefinite withstand
Max. output frequency	250kHz per output
Terminal type	8-way pluggable 3.5mm terminal block
Maximum cable length	150m. screened cable is recommended for all lengths, but essential if over 30m in order to comply with EMC regulations

Options

AC890/890PX series

SinCos registration position 8902-M1 and 8903-M1



Possible configurations

	8902-M1... fitted in slot C 8903-M1... not fitted	8902-M1... not fitted 8903-M1... fitted in slot A	8902-M1... fitted in slot C 8903-M1... fitted in slot A
Speed feedback Encoder	Via 8902-M1 card	Via 8903-M1 card	Via 8902-M1... card
Reference encoder signal		In this combination, a reference encoder position would normally be supplied by a FireWire option interface (8903/FA)	Supplied by 8903-M1... card
Registration	Available only using the encoder's 1V index pulse.	Auxiliary digital inputs and the encoder's index pulse (if supplied by the encoder) for registration even inputs	Auxiliary digital inputs and the encoder's index pulse (if supplied by the encoders) from both encoders are available for registration even inputs
Inputs/outputs		The auxiliary digital inputs are also available for general purpose digital inputs. Auxiliary digital inputs are also for simulated pulse encoder output, or for general purpose digital output	The auxiliary digital inputs are also available for general purpose digital inputs. Auxiliary digital inputs are also for simulated pulse encoder output, or for general purpose digital output

Example of two-mark registration

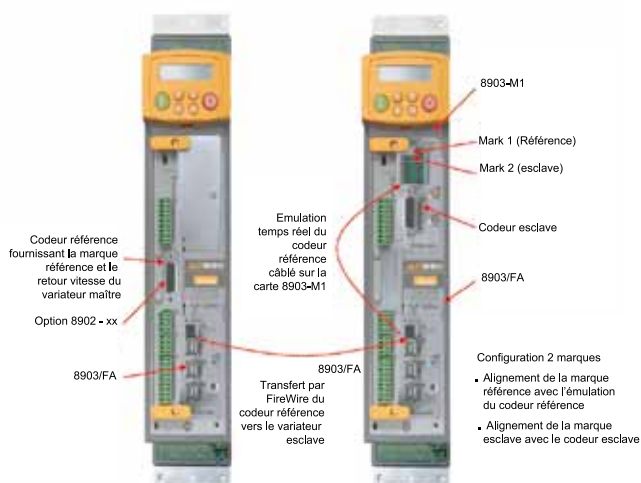
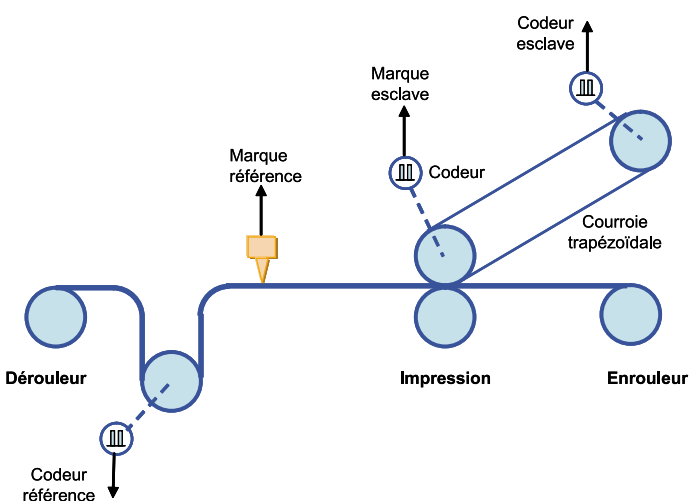

5

Accessories

For AC890/890PX series

Drive System Explorer (DSE) software

Description

DSE890 is the programming, monitoring and diagnostic software platform for AC890 and AC890PX series variable speed drives.

Communication between the drive and PC is via a mini USB port located on the front of the drive.

Thanks to the on-line help, users can achieve the optimum drive configuration without the need to navigate through complicated parameter menus.

Advanced programming is carried out through a set of pre-engineered templates in order to create the required configuration.

It is possible to monitor every parameter of the drive either as a digital value or as a function in the "chart recorder" during normal operation.

- Creates projects quickly and easily**
- Graphical tool based on a block diagram approach**
- Integrated digital oscilloscope**
- On-line configuration and monitoring**
- System identification tool**

Product codes

8906-DSELITE-00	DSE Lite software (single axis) + USB cable
8906-DSEDEV-00	DSE Development software + USB cable
8906-DSERUN-00	DSE Runtime/Maintenance + USB cable
8906-DSEDEVUPG-00	DSD Development to DSE Development Upgrade + USB cable
906-DSERUNUPG-00	DSD Runtime to DSE Runtime Upgrade + USB cable

DSE890 programming software

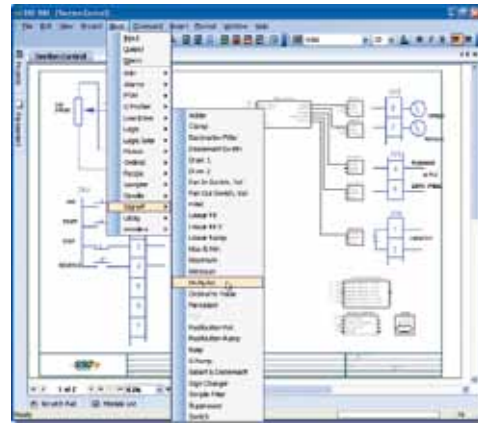

← Parameter adjustment and project creation



← real-time data acquisition oscilloscope

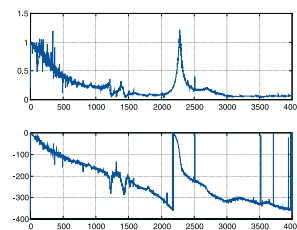

← System identification tool

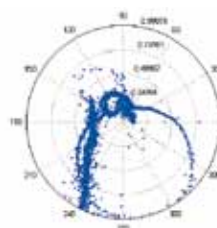

Accessories and options

For all AC drives

Drive System Explorer Lite (DSE Lite) software

Description

DSE LITE software is an easy to use configuration, commissioning and monitoring tool with graphical interface for the Parker SSD drives range of AC and DC drives.

While the drive is in running mode the oscilloscope function allows “on-line” monitoring of selected parameters and the recording of trends.

DSE LITE, allows the user to create, parameterize and configure user defined applications thanks to function blocks dedicated to speed control, Winder, PID, diameter calculator, Shaftless...

DSE LITE is downloadable from our website.
www.parker.com

