

High power modular AC drives

AC890PX series

110kW - 400kW

Description

The AC890PX is a high power standalone modular systems drive designed for industrial applications. It is especially fitted to retrofit applications where a complete standard enclosed drive system is required. It is particularly suited to the following applications :

- Energy-saving pump and fan applications
- Extruders,
- Mixers, centrifuges
- Engine Dynamometers

Features

Suitable for use with all types of AC motor

The AC890PX can control all types of AC motor :

- Induction motors
- PMAC servo motors
- Torque Motors

Operation with or without feedback

The drive can be configured for the following operating modes :

- V/F speed control
- Sensorless or full flux vector control
- PMAC Servo motor control

Compatible with a wide range of feedback options

Thanks to a range of optional feedback cards, the AC890PX works with all types of popular feedback systems :

- Incremental encoder
- Resolver
- SinCos (Endat 2.1) encoder
- Absolute encoder EnDat

Conforming to international standards

Suitable for supply voltages of 380Vac to 690Vac, the AC890PX can be connected to different supply networks around the world without any additional equipment. Meeting the requirements of key international standards, the AC890PX is supported in over 60 countries around the world through the Parker SSD Drives support network.



High power modular AC drive

AC890PX series

110kW - 400kW

Features (contd.)

Ultra-compact drive

The extremely compact footprint of the AC890PX is unmatched in the high power AC drives market. Within its small frame it integrates all of the standard equipment necessary for your installation: line choke, switch, fuses, second environment line filter (compliant to EN 61800-3). Configuration and start-up of the drive can be performed using the operator keypad in a matter of minutes.

Low-maintenance ensures maximum machine availability and productivity

Thanks to a plug in design, the power modules of the AC890PX have been designed to be replaceable in minutes by any technician, even a non-specialist. This helps to reduce machine downtime and lost productivity in the event of a fault occurring.

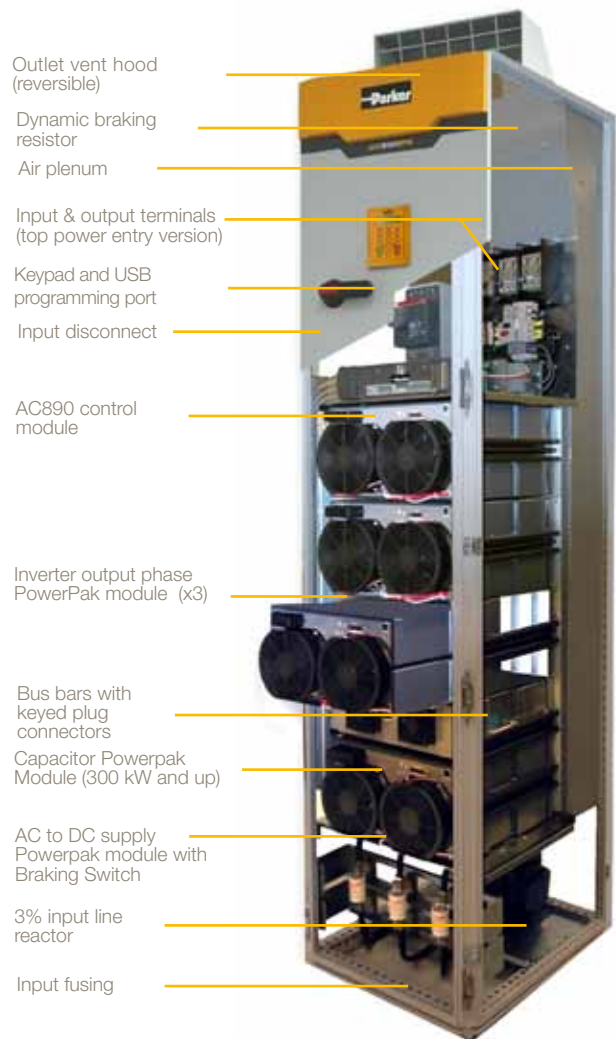

PowerPak Phase Module – Front View



PowerPak Phase Module - Rear View

TOP
CABLE
ENTRY / EXIT

BOTTOM
CABLE
ENTRY / EXIT



Total flexibility for easy factory integration

To facilitate maximum integration into the factory or existing buildings the AC890PX is available in a number of different variants :

- Top or bottom cable entry/exit to suit existing arrangements
- 12 or 18 pulse configuration
- Active Front-End with negligible harmonic distortion
- Integrated contactors, fuses, chokes etc.

Note : Certain variants require an additional enclosure bay.

High Power modular AC drive

AC890PX series

110kW - 400kW

Features (contd.)



Active Front-End (AFE) version - energy regeneration with low harmonic distortion

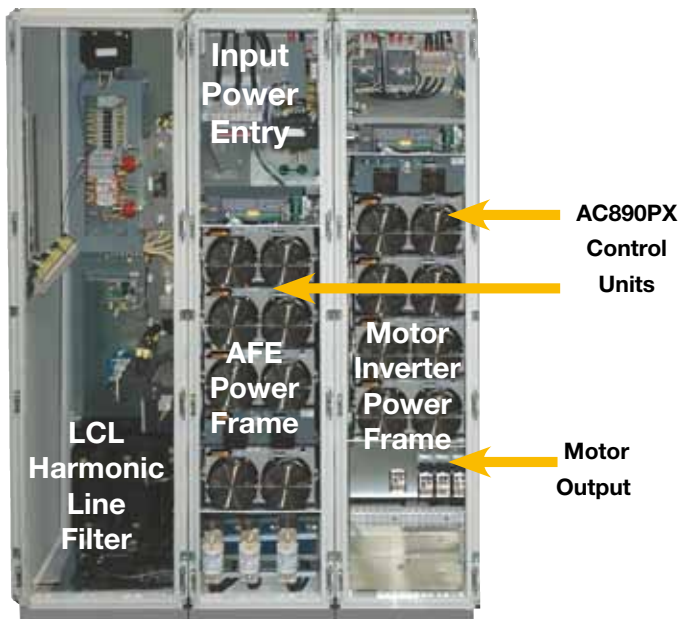

Fully line regenerative drive
Continuous duty at full torque - motoring or braking
Negligible power line harmonics - meets IEEE519
Unity power factor
Compact 3 bay (1600 mm) enclosure

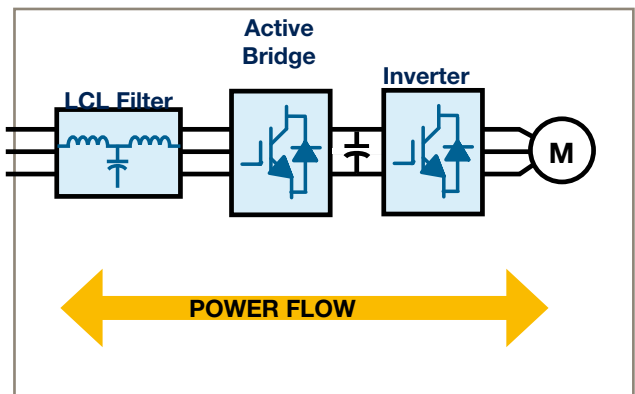

4

12 and 18 pulse input

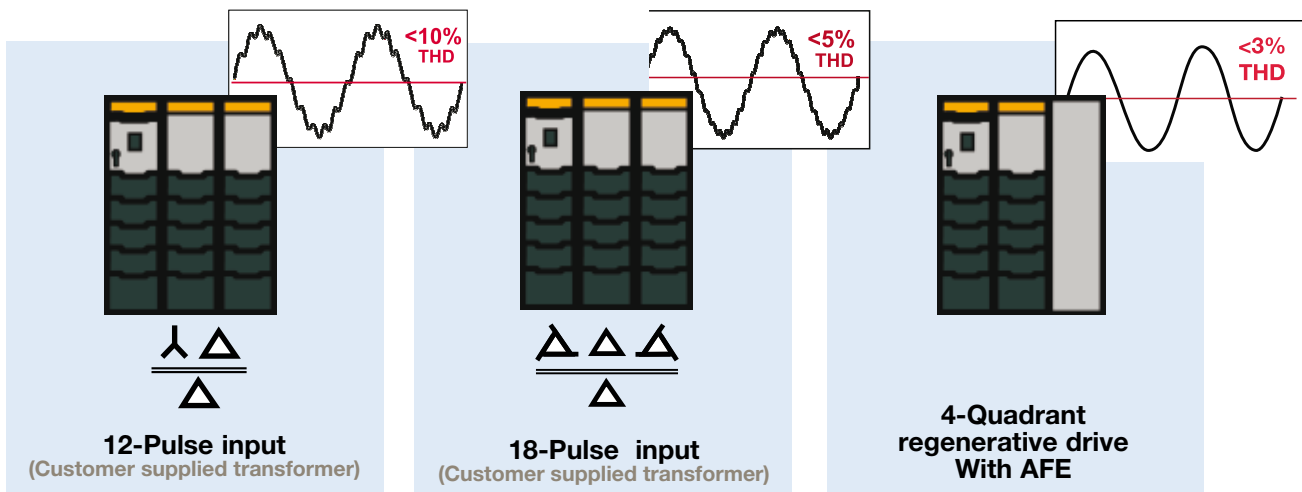

High power modular AC drive

AC890PX series

110kW - 400kW

Technical specifications

Range	Asynchronous motors	Servo motors
Supply voltage - 380 to 460Vac 3ph +/-10% - 500 to 575Vac 3ph +/-10% - 600 to 690Vac 3ph +/-10%	Standard duty [heavy] 132-400kW [110-315kW] 149-373kW [112-298kW] / 200-500HP [150-400HP] 132-400kW [110-315kW]	Heavy duty 155-410 Amps 60-155 Amps
Overload capacity Asynchronous motor - standard duty Asynchronous motor - heavy duty Servo motor - heavy duty	110% for 60 sec 150% for 60 sec 150% for 60 sec	
Output frequency	0 - 1000 Hz in V/F mode 0 - 350 Hz in Closed loop vector mode 0 - 120 Hz in Sensorless vector mode	
Switching frequency	2 kHz (standard) - Adjustable 4 kHz (derating required, consult factory). Suppression of audible frequencies	
Dynamic braking	Dynamic braking module integrated as standard (limited service) External braking resistor (option)	
Ambient temperature	0°C to 40°C	
IP rating	IP 21 / NEMA 1 as standard. IP 52 or greater available upon demand.	
Insulation	Cabinet provides an attenuation of 15dB to emissions between 30-100 MHz	
Humidity	90% maximum humidity at 40°C, without condensation	
Atmosphere	Non flammable, non corrosive, no dust	
Climate	Class 3k3, as defined by EN50178 (1998)	
Vibrations	Test Fc meeting EN60068-2-6	

4

Standards

Pollution index	Level II (non-conductive pollution, except for temporary condensation)
Europe	Low voltage directive 73/23/EEC with amendment 93/68/EEC, article 13 and annex III, EN50178 (1998) Conforms to EN61800-3 (second environment)
North America / Canada	Product conforms to UL specifications.



High power modular AC drive

AC890PX series

110kW - 400kW

Electrical characteristics

Product code	Asynchronous motors					Servo motors	
	Heavy duty / Constant torque	Standard duty / Variable torque	Heavy duty / Constant torque (Amps)	Standard duty / Variable torque (Amps)	Maximum current without overload	Standard duty / Variable torque (Amps)	Heavy duty / Constant torque (Amps)
400Vac Modules							
890PX/4/0215/B/00/A	110 kW	132 kW	215 A	260 A	265 A	190 A	155 A
890PX/4/0260/B/00/A	132 kW	160 kW	260 A	340 A	347 A	245 A	185 A
890PX/4/0300/B/00/A	160 kW	200 kW	300 A	390 A	398 A	285 A	210 A
890PX/4/0420/B/00/A	200 kW	250 kW	420 A	480 A	487 A	350 A	295 A
890PX/4/0480/B/00/A	250 kW	315 kW	480 A	600 A	609 A	435 A	340 A
890PX/4/0520/B/00/A	280 kW	355 kW	520 A	660 A	670 A	475 A	365 A
890PX/4/0580/B/00/A	315 kW	400 kW	580 A	720 A	731 A	520 A	410 A
460Vac Modules							
890PX/4/0215/B/00/A	120 kW/150HP	149 kW/200HP	200 A	250 A	255 A	190 A	155 A
890PX/4/0260/B/00/A	149 kW/200HP	187 kW/250HP	250 A	320 A	326 A	245 A	155 A
890PX/4/0300/B/00/A	187 kW/250HP	224 kW/300HP	300 A	380 A	388 A	285 A	210 A
890PX/4/0420/B/00/A	224 kW/300HP	298 kW/400HP	380 A	480 A	487 A	350 A	295 A
890PX/4/0480/B/00/A	298 kW/400HP	298 kW/400HP	460 A	590 A	599 A	435 A	340 A
890PX/4/0580/B/00/A	373 kW/500HP	448 kW/600HP	580 A	700 A	711 A	520 A	410 A
575Vac Modules							
890PX/6/0130/B/00/A	112 kW/150HP	149 kW/200HP	160 A	210 A	214 A	60 A	855 A
890PX/6/0160/B/00/A	149 kW/200HP	187 kW/250HP	210 A	250 A	255 A	75 A	105 A
890PX/6/0190/B/00/A	224 kW/300HP	224 kW/300HP	215 A	310 A	316 A	85 A	130 A
890PX/6/0280/B/00/A	120 kW/150HP	298 kW/400HP	310 A	420 A	426 A	125 A	185 A
890PX/6/0340/B/00/A	298 kW/400HP	298 kW/400HP	410 A	480 A	487 A	155 A	235 A
690Vac Modules							
890PX/7/0130/B/00/A	110 kW	132 kW	130 A	160 A	163 A	60 A	85 A
890PX/7/0160/B/00/A	132 kW	160 kW	160 A	190 A	194 A	75 A	105 A
890PX/7/0190/B/00/A	160 kW	200 kW	190 A	240 A	245 A	85 A	130 A
890PX/7/0230/B/00/A	200 kW	250 kW	230 A	280 A	286 A	105 A	150 A
890PX/7/0280/B/00/A	250 kW	315 kW	280 A	340 A	347 A	125 A	185 A
890PX/7/0320/B/00/A	280 kW	355 kW	320 A	390 A	398 A	145 A	210 A
890PX/7/0340/B/00/A	315 kW	400 kW	340 A	430 A	436 A	155 A	235 A

Selection and order code

Modular AC drives - AC890PX series



					Example ▶	890	PX	/	4	/	0580	/	B	/	00	/	A	/	UK	
Product family	AC890PX standard high power drive				890															
	AC890PX conformal coated PCB high power drive				891															
Product type	Modular Standalone drive					PX														
Power / current ratings	Supply Voltage	kW	Output Current (A)	HP																
	380-460V AC nominal							4												
		110	215	150																
		132	260	200							0215									
		160	300	250							0260									
		200	420	300							0300									
		250	480	400							0420									
		280	520	-							0520									
		315	580	500							0580									
		500-575V AC nominal							6											
		600-690V AC nominal							7											
		110	130	150							0130									
		132	160	200							0160									
		160	190	250							0190									
		200	230	-							0230									
		250	280	300							0280									
	280	320	-							0320										
	315	340	400							0340										
Brake switch	No brake switch																		N	
	Braking control including internal brake resistor (200kJ/2.4kW) and thermal OL protection fitted																		B	
Build options	Top cable entry																		00	
	Bottom cable entry																		01	
	Top entry no line choke																		02	
	Bottom entry no line choke																		03	
Performance	Advanced performance																		A	
	High performance																		H	
Language	French																		FR	
	German																		GR	
	Italian																		IT	
	Polish																		PL	
	Portuguese																		PO	
	Spanish																		SP	
	Swedish																		SW	
	English (50Hz)																		UK	
English (60Hz)																		US		

Accessories and options

AC890/AC890PX series



Options	Frame	Fitted	Reference	Page
Filter				
EMC filter	B	Option		167
Options cards				
Firewire peer-to-peer		Option	8903-FA-00	170
CAN peer-to-peer		Option	8903-CC-00	
Ethernet Modbus/TCP		Option	8903-IM-00	
Ethernet Ethernet/IP		Option	8903-IP-00	
Profinet		Option	8903-PN-00	
Profibus-DP		Option	8903-PB-00	
DeviceNet		Option	8903-DN-00	
CANopen		Option	8903-CB-00	
ControlNet		Option	8903-CN-00	
Resolver feedback		Option	8902-RE-00	
Resolver feedback with simulated incremental encoder		Option	8902-RR-00	
SinCos Endat 2.1 feedback		Option	8902-E1-00	171
Incremental quadrature encoder		Option	8902-EQ-00	
Incremental pulse encoder		Option	8902-EP-00	
SinCos Endat 2.1 feedback and registration		Option	8902-M1-00	172
SinCos Endat 2.1 master and registration		Option	8903-M1-00	
Incremental master encoder		Option	8903-EP-00	
High resolution analogue input		Option	8903-AI-00	
Accessories				
Standard compact keypad		Standard	6511-RS232-00-B	169
Alphanumeric keypad		Option	6901-00-B	
Graphical operator station		Option	6911-01-00-G	
Remote mounting kit for keypad		Option	6052-00-B	
Configuration tool software including USB cable		Option		175
System Busbars - frame B-D	B-D	Option	BH465850	169
Installation kit frame B-d	B-D	Standard	LA468430Uxx3	
Ventilation duct kit (1M exhaust for frames B,C,D)	B-D	Option	8905-DUCTKIT-190	
Ventilation fan kit frame B-D	B-D	Option	8905-DUCTFAN-190	

Accessories

AC890/AC890PX series



Keypad

Model	Description
6511-TTL-00	4 Digit LCD keypad*
6901/00	Alphanumeric multilingual keypad**
6911-01-00-G	Graphical operator station
6052/00	Remote mounting kit for 6901 with 3m cable

*Standard equipment for frames B - D

** Standard equipment for frames E - K



Screened power cables with connectors

Model	Description
CD1UA1F9R00xx	Power cable with motor connector for NX motor and $I_0 \leq 14A$ rms
CD1UP2F1R00xx	Power cable with motor connector for NX motor and $I_0 \leq 22A$ rms
CS4UA1F1R00xx	Resolver cable with motor connector and Sub-D connector for NX motor

Assembly kit

Model	Description
LA468430U003	Assembly kit for 890CS/CA
LA468430U103	Assembly kit for 890CD, B to D
LA468430U203	Assembly kit for 890SD, B to D
8905-DUCTKIT-00	Ventilation duct kit
8905-DUCTFAN-00	Ventilation duct fan

Cables

Model	Description
8905-USBCL1-00	USB programming cable for 890
8905-FWCBL200-00	FireWire cable 200 mm
8905-FWCBL280-00	FireWire cable 280 mm
8905-FWCBL1000-00	FireWire cable 1000mm
8905-FWCBL4500-00	FireWire cable 4.5 m

Busbar System

Model	Description
BH465850	DC SSD Rail/Bus Bar 140A (UL) 1m
BC465938U200	Insulator for DC bus bars 200mm

Options

AC890/890PX series

Communication interfaces



Modbus/TCP (8903-IM-00) and Ethernet IP (8903-IP-00)

Supported protocols	Card 8903-IM-00 : Modbus/TCP Card 8903-IP-00 : Ethernet IP
Communication speed	10/100M bits/s
Station Address	By Drive System Explorer software via RTNX protocol
Suitable for Drives	AC890 version 3.2+

DeviceNet (8903-DN-00)

Supported protocols	Supports the group 2 only slave subset of the DeviceNet protocol
Supported messages	Polled I/O, cyclic outputs, change of state (COS), Explicit messaging
Communication speed	125K, 250K et 500K bits/s
Station address (MACID)	Dip switch or software setting of station address and network speed
Suitable for drives	AC890 version 1.9+

CanOpen (8903-CB-00)

Profile	DS402
Supported messages	SDO, PDO, NMT, SYNC
Communication speed	20K, 50K, 125K, 250K, 500K, 1M bits/s selectable by software or dip switch setting
Station address	Dip switch or software setting of station address and network speed
Suitable for drives	AC890 version 1.3+

ControlNet (8903-CN-00)

Supported messages	Polled I/O
Station address	Selectable by software
Station address	Selectable by dip switch
Suitable for drives	AC890 version 1.4+

Profibus-DP (8903-PB-00)

Supported protocols	Profibus-DP ; demand data and data exchange
Communication speed	Up to 12M bits/s selected by the master
Station address	Dip switch or software setting of station address
Suitable for drives	AC890 version 1.4+

FireWire IEEE 1394 (8902-FA-00)

Communication Supported	peer-to-peer communication between drives
-------------------------	---

Profinet (8903-PN-00 and 8903-PN-FF)

Supported protocols	Profinet I/O RT protocol
Station address (IP)	Software setting of IP address via DSE
Suitable for drives	AC890 version 3.3+

Peer to peer (8903-SP-00 and 8903-SP-FF)

Supported protocols	Peer to peer data exchange with other drives
Communications speed	up to 1M bits/s selectable by dip switch
Suitable for drives	AC890 version 3.3+



5

Options

AC890/890PX series

Incremental quadrature encoder card 8902-EQ



Description

The HTTL 8902-EQ speed feedback option allows incremental encoders to be connected directly to the drive to provide highly accurate speed feedback measurement. Supplies variable voltage isolated encoder power supply.

Product codes

Code	Description
8902-EQ-00-00	Optional HTTL incremental encoder
8902-EQ-00-FF	Option HTTL encoder factory-fitted

Features

Maximum pulse rate	250kHz (differential) 200kHz (single ended)
Receiver current	≤10mA per channel
Input format	Two differential channels in quadrature (Clock/direction or clock only)
Input voltage	±30V (differential), 0-30V (single-ended)
Input voltage differential	±30V maximum
Input voltage threshold dip switch settings	3V ± 1V (differential) 8V ± 1V (single-ended)
Encoder power supply	Maximum load 200mA or 2W



5

Options

AC890/890PX series

Resolver feedback card 8902-RE



Description

The 8902-RE resolver speed feedback option allows the resolver to be connected directly to the drive to provide highly accurate speed feedback measurement. Contains a carrier output signal to power the resolver.

Product codes

Code	Description
8902-RE-00-00	Optional resolver feedback card
8902-RE-00-FF	Option resolver feedback factory-fitted

Features

Maximum speed	Up to 50 000 RPM (with 2 pole resolver)
Carrier output signal	7V rms, 8kHz
Maximum carrier supply	70mA rms
Maximum input voltage	±12V peak
Accuracy	< 5 minutes
Resolution	Equivalent to 16 bits in one revolution of resolver
Inputs	Differential inputs Zin ~2 kΩ
Maximum input voltage	12Vpeak

SinCos Endat 2.1 feedback card 8902-E1



Description

The SinCos speed feedback option 8902-E1 allows a 1V p-p Sin/Cos encoder to be connected directly to the drive to provide highly accurate speed feedback measurement. Decodes Heidenhain Endat 2.1 absolute position encoders and supplies 5V or 10V for the encoder.

Product codes

Code	Description
8902-E1-00-00	Optional SinCos encoder card
8902-E1-00-FF	Optional SinCos card factory-fitted

Features

Maximum pulse rate	250kHz
Receiver impedance	120Ω
Input format	two differential 1V p-p signals in quadrature
Encoder supply	Maximum load 250mA Adjustable Voltage 5V/10V

Options

AC890/890PX series

SinCos registration position 8902-M1 and 8903-M1



Description

The 8903-M1-00 and 8902-MA-00 feedback cards allow operation without external registration position, thanks to the connection of the encoder to the drive. They provide highly accurate speed feedback measurement and registration. Nevertheless registration applications are best achieved when both cards are used.

- Registration achieved in the drive
- Interpolates each encoder line with 11-bit accuracy giving 4 million counts / rev. on a 2048 line encoder
- Optional 1V input from 'Z' index pulse for use with registration
- Supplies 5V or 10V to the encoder
- Decodes Heidenhain Endat 2.1 absolute position encoders
- 4 optically isolated auxiliary digital outputs that can be used either for general purpose inputs, or for inputs from registration mark sensor (8903-M1 only)
- 3 non-isolated auxiliary digital outputs that can be either for general purpose outputs or for synthesizing an encoder output (8903-M1 only)

Product codes

Code	Description
8902-M1-00	Slave SinCos registration
8903-M1-00	Master SinCos registration
8902-M1-FF	Slave SinCos registration factory-fitted
8903-M1-FF	Master SinCos registration factory-fitted

Approved encoders

	1V p-p	Endat 2.1	Single Turn ABS	Multi-turn ABS
Heidenhain :				
EQN425	√	√		√
ECN413	√	√	√	
ERN480	√			
Stegmann :				
HG660 AKR (xxxx)S	√			
HG660 DKR (xxxx)S	√			
Hengstler :				
RIS58-H	√			

Specification

Encoder inputs (8902-M1... and 8903-M1...)

Maximum pulse rate	250kHz
Receiver impedance	120Ω
Input format	2 differential 1V p-p signals in quadrature
Encoder supply	250mA Maximum load
Supply voltage	5V/10V adjustable
Terminal type	Sub-D15 connector
Maximum cable length	150m screened cable
Serial protocol	Endat 2.1

Additional digital inputs (8903-M1... only)

Low logic level	0V to 5V relative to X63 pin 5
High logic level	15V to 26V relative to X63 pin 5
Absolute Max. input Voltage	30V relative to X63 pin 5
Input current	Low logic level < 1mA High logic level > 3mA, < 10mA Typical input at 24V : 7mA
Isolation withstand relative to drive chassis	30V
Input safety category	SELV
Terminal type	6-way pluggable 3.5mm terminal block
Maximum cable length	150m. screened cable is recommended for all lengths, but essential if over 30m in order to comply with EMC regulations

Auxiliary digital outputs (8903-M1... only)

Input voltage (VS)	5V to 24V
Maximum input voltage	30V
Maximum output current	± 100mA per output
Output voltage	Low logic level < 3V to 100mA High logic level > VS – 4V to 100mA
Overload and short circuit duration	Indefinite withstand
Max. output frequency	250kHz per output
Terminal type	8-way pluggable 3.5mm terminal block
Maximum cable length	150m. screened cable is recommended for all lengths, but essential if over 30m in order to comply with EMC regulations

Options

AC890/890PX series

SinCos registration position 8902-M1 and 8903-M1



Possible configurations

	8902-M1... fitted in slot C 8903-M1... not fitted	8902-M1... not fitted 8903-M1... fitted in slot A	8902-M1... fitted in slot C 8903-M1... fitted in slot A
Speed feedback Encoder	Via 8902-M1 card	Via 8903-M1 card	Via 8902-M1... card
Reference encoder signal		In this combination, a reference encoder position would normally be supplied by a FireWire option interface (8903/FA)	Supplied by 8903-M1... card
Registration	Available only using the encoder's 1V index pulse.	Auxiliary digital inputs and the encoder's index pulse (if supplied by the encoder) for registration even inputs	Auxiliary digital inputs and the encoder's index pulse (if supplied by the encoders) from both encoders are available for registration even inputs
Inputs/outputs		The auxiliary digital inputs are also available for general purpose digital inputs. Auxiliary digital inputs are also for simulated pulse encoder output, or for general purpose digital output	The auxiliary digital inputs are also available for general purpose digital inputs. Auxiliary digital inputs are also for simulated pulse encoder output, or for general purpose digital output

Example of two-mark registration

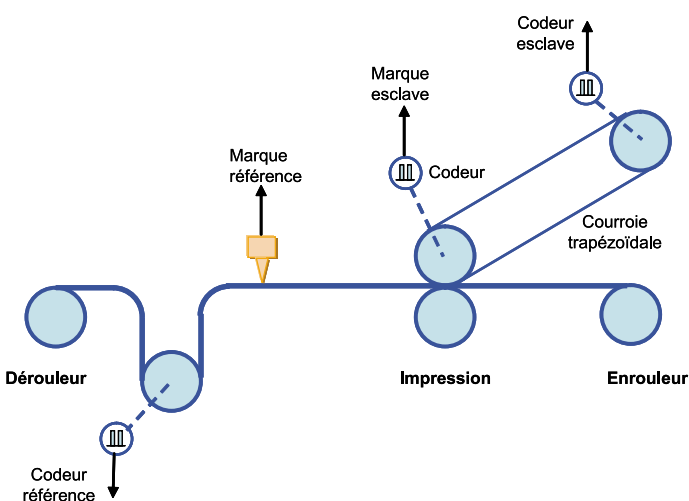

5

Accessories

For AC890/890PX series

Drive System Explorer (DSE) software

Description

DSE890 is the programming, monitoring and diagnostic software platform for AC890 and AC890PX series variable speed drives.

Communication between the drive and PC is via a mini USB port located on the front of the drive.

Thanks to the on-line help, users can achieve the optimum drive configuration without the need to navigate through complicated parameter menus.

Advanced programming is carried out through a set of pre-engineered templates in order to create the required configuration.

It is possible to monitor every parameter of the drive either as a digital value or as a function in the "chart recorder" during normal operation.

- Creates projects quickly and easily**
- Graphical tool based on a block diagram approach**
- Integrated digital oscilloscope**
- On-line configuration and monitoring**
- System identification tool**

Product codes

8906-DSELITE-00	DSE Lite software (single axis) + USB cable
8906-DSEDEV-00	DSE Development software + USB cable
8906-DSERUN-00	DSE Runtime/Maintenance + USB cable
8906-DSEDEVUPG-00	DSD Development to DSE Development Upgrade + USB cable
906-DSERUNUPG-00	DSD Runtime to DSE Runtime Upgrade + USB cable

DSE890 programming software

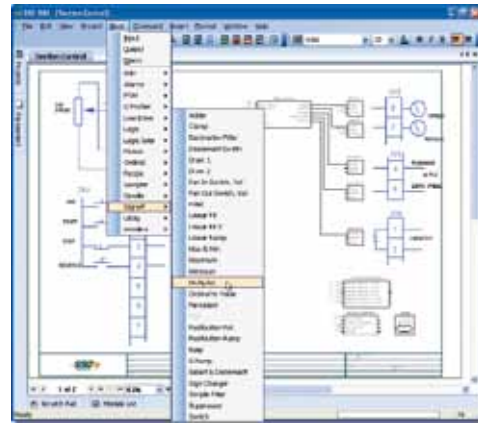

← Parameter adjustment and project creation

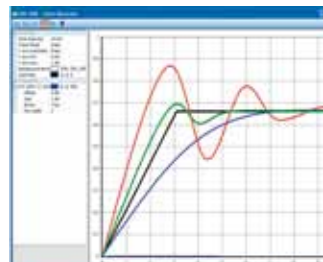

← real-time data acquisition oscilloscope

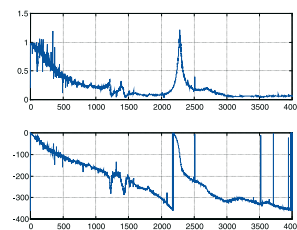

← System identification tool

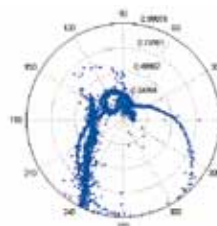

Accessories and options

For all AC drives

Drive System Explorer Lite (DSE Lite) software

Description

DSE LITE software is an easy to use configuration, commissioning and monitoring tool with graphical interface for the Parker SSD drives range of AC and DC drives.

While the drive is in running mode the oscilloscope function allows “on-line” monitoring of selected parameters and the recording of trends.

DSE LITE, allows the user to create, parameterize and configure user defined applications thanks to function blocks dedicated to speed control, Winder, PID, diameter calculator, Shaftless...

DSE LITE is downloadable from our website.
www.parker.com

